

ENGINEERING
TOMORROW



Operating Guide

VACON® NXP Advanced Safety Options

OPTBL, OPTBM, OPTBN

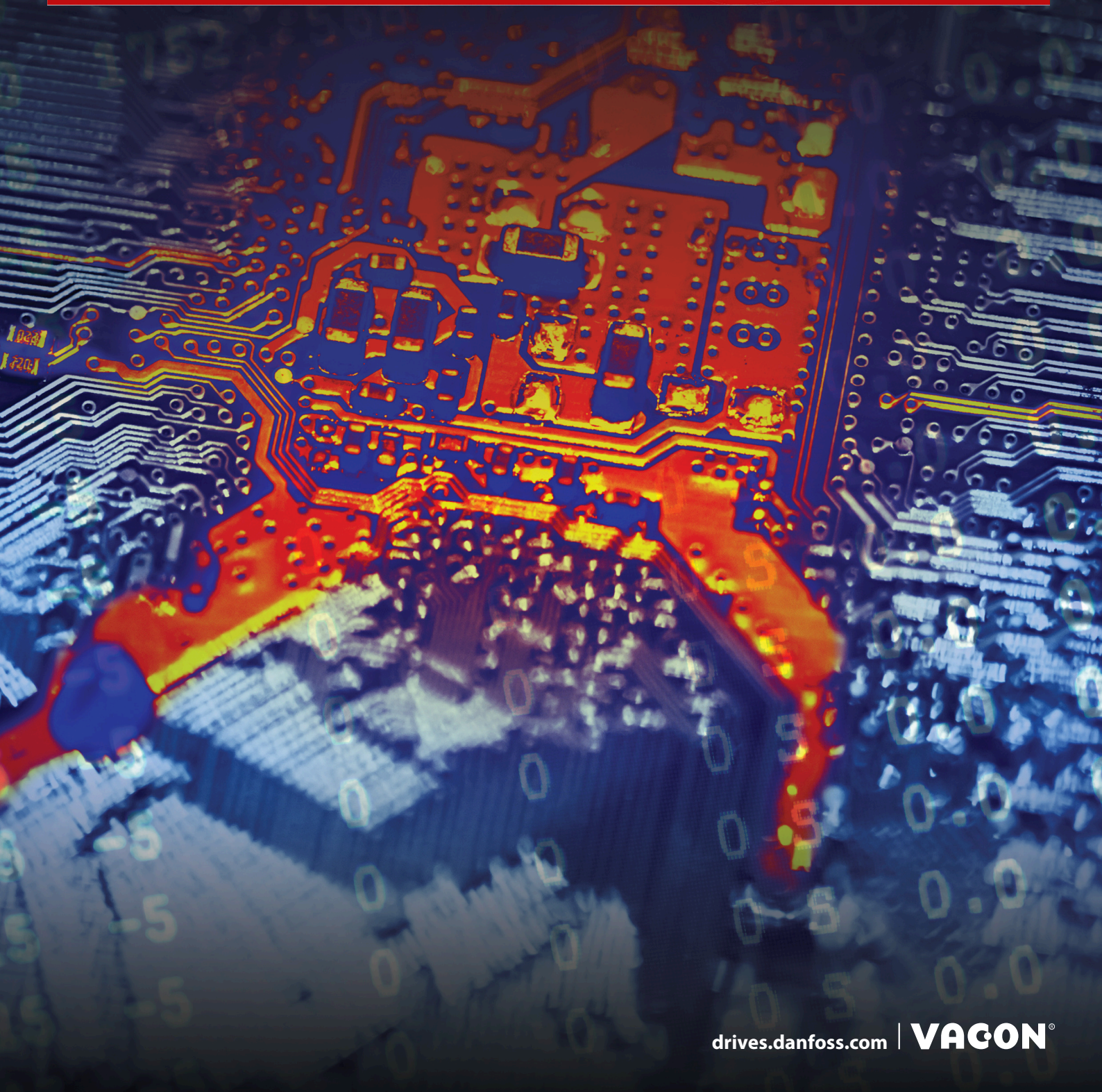

Contents

1	Introduction	9
1.1	Purpose of the Manual	9
1.2	Additional Resources	9
1.3	Manual and Software Version	10
1.4	Approvals and Certificates	12
1.5	Product Overview	15
1.6	Terms and Abbreviations	16
2	Safety	19
2.1	Safety Symbols	19
2.2	Danger and Warnings	19
2.3	Cautions and Notices	20
2.4	Grounding	22
3	Overview of the System	24
3.1	Using the Advanced Safety Options	24
3.2	The Safe State	24
3.3	Integration and Interfaces to Other Systems	25
3.4	Determining the Achieved Safety Level	25
3.5	Advanced Safety Option Variants	27
3.5.1	General Information	27
3.5.2	Input Configuration	27
3.5.3	Output Configuration	28
3.5.4	Option Board OPTBL	30
3.5.5	Option Board OPTBM	31
3.5.6	Option Board OPTBN	32
3.5.7	Closed-loop Control with OPTBM	33
3.5.8	Closed-loop Control with OPTBN	33
3.6	Speed Measurement	33
3.6.1	Safety Speed Sensors	33
3.6.2	Standard Speed Sensors and Combinations	33
3.6.3	Speed Discrepancy with Multiple Speed Sources	35
3.6.4	Encoders	35
3.6.5	Proximity sensors	38
3.6.6	Encoder Signal Verification	39
3.6.7	Usage of Only One Speed Sensor	39
3.6.8	Estimated Speed	40

3.6.9	Estimated Speed and Gear Systems	42
3.6.10	Estimated Speed and External Accelerative Forces	43
3.7	Storage of Parameters	43
3.7.1	Storing a Parameter File Backup	44
3.7.2	Restoring a Parameter File from Backup	44
3.8	Advanced Safety Options with the NXP Drive	44
3.8.1	Requirements	44
3.8.2	Compatibility with Drive Applications	45
3.8.3	Option Board Menu on the Control Panel	45
3.8.4	Fault Types	49
4	Installation	51
4.1	Installation Safety	51
4.2	Installing the Option Board	51
5	VACON Safe Tool	53
5.1	Functions of the VACON Safe Tool	53
5.2	The Parameter File	53
5.3	User Levels and Password Management	53
5.4	Setting the Parameters	54
5.5	Saving a Verified Parameter File to the Option Board	56
5.6	Online Monitoring	56
5.6.1	Viewing the State of the Option Board	56
5.6.2	Activity Log	56
6	Safety Functions	57
6.1	General Information	57
6.1.1	The Different Safety Functions	57
6.1.2	Safety Function States	57
6.1.3	Activation of a Safety Function	58
6.1.4	Violation of a Safety Function	58
6.1.5	Acknowledgment of a Safety Function	59
6.1.5.1	Acknowledgment of a Safety Function	59
6.1.5.2	Start-up Acknowledgment	63
6.1.6	Reset of a Safety Function	63
6.1.7	Ramps	64
6.2	Safe Stopping Functions	66
6.2.1	Introduction to the Safe Stopping Functions	66
6.2.2	STO - Safe Torque Off and SBC - Safe Brake Control	67

6.2.2.1	Introduction to the STO and SBC Functions	67
6.2.2.2	The STO Function Used without the SBC Function	68
6.2.2.3	The STO Function Used with the SBC Function	68
6.2.2.4	The STO and SBC Signals	69
6.2.3	SS1 - Safe Stop 1	73
6.2.3.1	Introduction to the SS1 Function	73
6.2.3.2	Time Monitoring	74
6.2.3.3	Zero Speed Monitoring	74
6.2.3.4	Ramp Monitoring	75
6.2.3.5	The SS1 Signals	75
6.2.4	SS2 - Safe Stop 2 and SOS - Safe Operating Stop	78
6.2.4.1	Introduction to the SS2 and SOS Functions	78
6.2.4.2	Time Monitoring	79
6.2.4.3	Zero Speed Monitoring	79
6.2.4.4	Ramp Monitoring	80
6.2.4.5	The SOS Safety Function	80
6.2.4.6	The SS2 and SOS Signals	80
6.2.5	SQS - Safe Quick Stop	84
6.2.5.1	Introduction to the SQS Function	84
6.2.5.2	The SQS Modes	85
6.2.5.3	The SQS Signals	85
6.3	Safe Monitoring Functions	89
6.3.1	Introduction to the Safe Monitoring Functions	89
6.3.2	SLS - Safe Limited Speed	90
6.3.2.1	Introduction to the SLS Function	90
6.3.2.2	Time Monitoring	90
6.3.2.3	Ramp Monitoring	91
6.3.2.4	The Speed Limit Selection of the SLS Function	91
6.3.2.5	The SLS Signals	92
6.3.3	SMS - Safe Maximum Speed	96
6.3.3.1	Introduction to the SMS Function	96
6.3.3.2	The Maximum Speed Monitoring	96
6.3.3.3	The SMS Signals	97
6.3.4	SSR - Safe Speed Range	99
6.3.4.1	Introduction to the SSR Function	99
6.3.4.2	Time Monitoring	99
6.3.4.3	Ramp Monitoring	100
6.3.4.4	The SSR Signals	101

6.3.5	SSM - Safe Speed Monitor	103
6.3.5.1	Introduction to the SSM Function	103
6.3.5.2	Speed Monitoring	104
6.3.5.3	The SSM Safe Output	104
6.3.5.4	The SSM Signals	105
6.4	Combinations of Safety Functions	109
7	Safe Fieldbuses	111
7.1	PROFIsafe	111
7.1.1	Introduction to PROFIsafe	111
7.1.2	The Requirements and Restrictions	111
7.1.3	Overview of the PROFIsafe System	112
7.1.4	The PROFIsafe Frame	112
7.1.5	Parameterization for PROFIsafe	113
7.1.5.1	General Information on Parameterization	113
7.1.5.2	PROFIsafe Watchdog Time	114
7.1.5.3	The PROFIsafe Safety Function Response Time (SFRT)	115
7.1.6	PROFIdrive on PROFIsafe	115
7.1.6.1	General Information on PROFIdrive on PROFIsafe	115
7.1.6.2	PROFIsafe over PROFIBUS	116
7.1.6.3	PROFIsafe over PROFINET	117
7.1.6.4	Data Mapping for PROFIdrive on PROFIsafe	117
7.1.6.5	Safety Control Word 1 (S_STW1)	117
7.1.6.6	Safety Status Word 1 (S_ZSW1)	118
7.1.6.7	Safety Control Word 2 (S_STW2)	119
7.1.6.8	Safety Status Word 2 (S_ZSW2)	120
7.1.6.9	VACON Safety Control Word (VS_CW)	122
7.1.6.10	VACON Safety Status Word (VS_SW)	123
8	Parameter List	125
8.1	General Parameters	125
8.1.1	Parameter File Parameters	125
8.1.2	Common Safety Function Parameters	125
8.1.3	Speed Measurement Parameters	125
8.1.4	Ramp Parameters	126
8.1.5	Estimated Speed Parameters	127
8.2	Safe I/O Parameters	127
8.2.1	Digital Input/Output Parameters	127
8.3	Safe Fieldbus Parameters	129

8.3.1	PROFIsafe Parameters	129
8.4	STO and SBC Parameters	129
8.5	SS1 Parameters	130
8.6	SS2 and SOS Parameters	130
8.7	SQS Parameters	131
8.8	SLS Parameters	132
8.9	SMS Parameters	132
8.10	SSR Parameters	133
8.11	SSM Parameters	133
8.12	Validation Parameters	134
9	Commissioning and Validation	135
9.1	Preparing for Commissioning	135
9.1.1	Preparing for Commissioning	135
9.1.2	Procedures Before the First Start-up of the System with the Option	135
9.2	Doing the First Start-up After the Installation of the Option Board	136
9.3	Validating the Parameter File	137
9.4	Checklist before Taking the System into Use	137
9.5	Bypassing Safety Features	137
10	Operation and Maintenance	139
10.3	Resetting the Password	141
10.4	Factory Reset	141
10.5.1	Updating the Firmware	142
10.6	Replacing the Option Board	143
10.7	Replacement of Other Components of the Safety System	143
10.8	Disposal	144
11	Technical Data	145
11.1	Safety Data	145
11.2	Safe Input/Output Data	145
11.3	Speed Measurement Data	147
11.4	Safe Fieldbus Data	149
11.5	Environmental Data	149
12	Fault Tracing	150
12.1	Presentation of Faults on the Control Board	150
12.2	Fault Codes	151
12.3	OPTAF STO and ATEX Option Board Fault Information	172

13 Configuration Examples	173
13.1 General Information	173
13.2 Emergency Stop Using the STO Function	173
13.3 SS1 Used with STO(+SBC)	174
13.4 SS1 Without a Direct Support of the Drive Application	176
13.5 Light Curtain Control of SLS	177
13.6 SLS without a Direct Support of the Drive Application	180
13.7 Using an Output of the Option Board to Control the Access to an Area	182
13.8 PROFIdrive over PROFIsafe Using the PROFIBUS or PROFINET Option Board	185
13.9 A Proximity Sensor for Speed Measurement	187

1 Introduction

1.1 Purpose of the Manual

This manual describes the VACON[®] Advanced Safety Options (OPTBL, OPTBM, or OPTBN). The VACON[®] Advanced Safety Options can be used with the VACON[®] NXP AC drive.

The operating guide is intended for use by qualified personnel, who are familiar with the VACON[®] drives and functional safety. To use the product safely, read and follow the operating instructions.

1.2 Additional Resources

Resources Available for the Drive and Optional Equipment

- VACON[®] NX OPTAF STO Board Manual
- VACON[®] NX All in One Application Guide - information on working with parameters and many application examples
- VACON[®] OPT3/E5 PROFIBUS DP User Guide
- VACON[®] NX I/O Boards User Manual
- VACON[®] OPT3A/OPT9 Ethernet Board User Guide
- VACON[®] Ethernet Option Boards Installation Guide
- VACON[®] RS485 and CAN Bus Option Boards Installation Guide
- VACON[®] NXP Advanced Safety Options Quick Guide
- The Operating Guide of the AC drive provides the necessary information to get the drive up and running.

Supplementary publications and manuals are available from drives.danfoss.com/knowledge-center/technical-documentation/.

Standards, specifications, and official recommendations

- EN IEC-62061 – Safety of machinery – Functional safety of safety-related electrical, electronic and programmable electronic control systems, 2005
- IEC 61784-3 – Industrial communication networks – Profiles – Part 3: Functional safety fieldbuses - General rules and profile definitions, 2010
- EN ISO 13849-1 – Safety of machinery – Safety-related parts of control systems – Part 1: General principles for design, 2015
- EN IEC 60204-1 – Safety of machinery – Electrical equipment of machines – Part 1: General requirements, 2006
- EN IEC 61800-5-2 – Adjustable speed electrical power drive systems – Part 5-2: Safety requirements – Functional, 2007
- IEC 61508 – Functional safety of electrical/electronic/programmable electronic safety related systems, 2010
- EN ISO 12100 – Safety of machinery -- General principles for design -- Risk assessment and risk reduction, 2010
- ISO 14121-1 – Safety of machinery -- Risk assessment -- Part 1: Principles, 2007
- Amendment – PROFIdrive on PROFIsafe Interface for functional safety; Technical Specification for PROFIBUS and PROFINET related to PROFIdrive – Profile Drive Technology V4.1, Version 3.00.4, April 2011, Order No.: 3.272
- PROFIsafe – Profile for Safety Technology on PROFIBUS DP and PROFINET IO, Version 2.4, March 2007, Order No: 3.192b
- Recommendation of Use CNB/M/11.050, rev 05; European co-ordination of Notified Bodies for Machinery, 2013
- BGIA Report 2/2008e Functional safety of machine controls – Application of EN ISO 13849 –, 2009

Software and Configurations Files

- The firmware for the Advanced Safety Option, <https://www.danfoss.com/en/service-and-support/downloads/dds/fieldbus-firmware/>.
- VACON[®] Safe, <https://www.danfoss.com/en/service-and-support/downloads/dds/vacon-safe/>.
- The GSD/GSDML file, <https://www.danfoss.com/en/service-and-support/downloads/dds/fieldbus-configuration-files/>.

For US and Canadian markets:

NOTE! Download the English and French product guides with applicable safety, warning and caution information from <https://www.danfoss.com/en/service-and-support/>.

REMARQUE Vous pouvez télécharger les versions anglaise et française des guides produit contenant l'ensemble des informations de sécurité, avertissements et mises en garde applicables sur le site <https://www.danfoss.com/en/service-and-support/>.

1.3 Manual and Software Version

This manual is regularly reviewed and updated. All suggestions for improvement are welcome.

The original language of this manual is English.

Always make sure that you use the latest or correct revision of the manual when assessing the behavior of the Advanced safety option board.

Table 1: Manual and Software Version

Manual version	New features	Firmware version	Hardware version
DPD01798B	The first published version of this manual.		
DPD01798C	<ul style="list-style-type: none"> PROFIsafe over PROFINET information added. Chapter Safe fieldbuses and throughout the manual. Version history table added. Table linking option board names to option board codes. Chapter 3.5.1 General Information. Images edited. Chapters VACON Advanced Safety Option variants and Configuration examples. Warning added. Chapter 6.1.4 Violation of a Safety Function. Fault settings table added. Chapter 3.8.3 Option Board Menu on the Control Panel. Safety bypass procedure updated. Chapter 9.5 Bypassing Safety Features. Fault codes edited. Chapter Fault codes. New configuration example on SLS without drive application support added. Chapter 13.6 SLS without a Direct Support of the Drive Application. Configuration examples numbered. Chapter Configuration examples. Other minor updates. Throughout the manual. 		
DPD01798D	<ul style="list-style-type: none"> Safety function acknowledgment and reset descriptions updated to match new behavior. Chapters 6.1.5.1 Acknowledgment of a Safety Function and 6.1.6 Reset of a Safety Function. Example of system level calculations updated. Chapter 3.4 Determining the Achieved Safety Level. Encoder terminals updated. Chapters 3.5.5 Option Board OPTBM and 3.5.6 Option Board OPTBN. Option board installation instructions updated. Chapter 4.2 Installing the Option Board. Extended slot support and example configuration updated. Chapter 3.1 Using the Advanced Safety Options. Comment on closed-loop control added. Chapter 3.6.7 Usage of Only One Speed Sensor. Old parameters edited and new added. Chapter 3.8.3 Option Board Menu on the Control Panel. Watchdog times updated. Chapter 7.1.5.2 PROFIsafe Watchdog Time. Technical details updated. Chapter 11.1 Safety Data. Fault codes updated. Chapter Fault codes. Images edited. Chapters 3.1 Using the Advanced Safety Options, 3.6.8 Estimated Speed, 6.2.3.5 The SS1 Signals, 6.3.4.2 Time Monitoring, 6.3.4.3 Ramp Monitoring, 13.3 SS1 Used with STO(+SBC), 13.5 Light Cur- 	FW0281V001 or later	70CVB01938 F (141X4588) or later, 70CVB01957 F (141X4608) or later, 70CVB01958 E (141X4610) or later

Manual version	New features	Firmware version	Hardware version
	<p>tain Control of SLS, and 13.6 SLS without a Direct Support of the Drive Application.</p> <ul style="list-style-type: none"> Other minor updates. Throughout the manual. 		
DPD01798E	<ul style="list-style-type: none"> New chapter added, 3.6.3 Speed Discrepancy with Multiple Speed Sources. Information on internal variables added. Chapter 10.1 Gathering Diagnostic Data. Some fault numbers for fault code 20 Safety system updated. Chapter Fault codes. OPTAF option board fault information added. Chapter 12.3 OPTAF STO and ATEX Option Board Fault Information. Other minor updates. Throughout the manual. 	FW0281V001 or later	70CVB01938 F (141X4588) or later, 70CVB01957 F (141X4608) or later, 70CVB01958 E (141X4610) or later
DPD01798F	<ul style="list-style-type: none"> PROFINET IO/PROFIsafe Certificate updated. 1.4 Approvals and Certificates. Changes in layout and structure. 	FW0281V001 or later	70CVB01938 F (141X4588) or later, 70CVB01957 F (141X4608) or later, 70CVB01958 E (141X4610) or later
DPD01798G	<ul style="list-style-type: none"> Updated status byte and PLC safety setting descriptions for PROFISafe. 	FW0281V001 or later	70CVB01938 F (141X4588) or later, 70CVB01957 F (141X4608) or later, 70CVB01958 E (141X4610) or later

1.4 Approvals and Certificates

ZERTIFIKAT ◆ CERTIFICATE ◆ 認証証書 ◆ CERTIFICADO ◆ CERTIFICAT

e30b1948.10

CERTIFICATE

No. Z10 17 03 99224 001



Holder of Certificate: Vacon ltd
 Runsorintie 7
 65380 Vaasa
 FINLAND

Factory(ies): 98422



Product: Safety Related Programmable Electronic System
 Advanced Safety Option Card for
 Vacon NXP AC drive

Model(s): OPTBL, OPTBM, OPTBN

Parameters:
 Safety functions: STO, SBC, SS1, SS2, SOS,
 SLS, SMS, SSR, SSM
 Safety integrity: up to SIL 3

Tested according to:
 IEC 61508-1(ed.2)
 IEC 61508-2(ed.2)
 IEC 61508-3(ed.2)
 IEC 61508-4(ed.2)
 EN ISO 13849-1:2015 (up to PL e, Cat. 4)
 EN 61800-5-2:2007
 IEC 61511-1(ed.2)
 EN 62061:2005/A2:2015

The product was tested on a voluntary basis and complies with the essential requirements. The certification mark shown above can be affixed on the product. It is not permitted to alter the certification mark in any way. In addition the certification holder must not transfer the certificate to third parties. See also notes overleaf.

Test report no.: SB90504T

Valid until: 2022-04-02

Peter Weiss
Date, 2017-04-03 **(Peter Weiss)**



Page 1 of 1

TÜV SÜD Product Service GmbH · Zertifizierstelle · Ridlerstraße 65 · 80339 München · Germany

TUV®

A17_04-11

Illustration 1: TÜV Certificate



Certificate

PROFIBUS Nutzerorganisation e.V. grants to

Vacon Ltd

Runsorintie 7, 65380 VAASA, FINLAND

the Certificate No: **Z20212** for the PROFIsafe Device:

Model Name: Vacon OPTEA, OPTBL, OPTBM, OPTBN Advanced Safety Option
 Order-Number: OPTBL, OPTBM, OPTBN
 Revision: SW/FW: V4.0.0; HW: 6
 Application CRC: Channel A: 0x84C3
 Channel B: 0xCB77

This certificate confirms that the product has successfully passed the certification tests with the following PROFIsafe scope:

PROFIsafe_V2 functionality on PROFINET IO

Test Report Number: PS127-2
 Authorized Test Laboratory: SIEMENS AG, Fürth, Germany

The tests were executed in accordance with the following documents:
 "PROFIsafe - Test Specification for F-Slaves, F-Devices, and F-Hosts, Version 2.1, March 2007".

This certificate is granted according to the document:
 "Framework for testing and certification of PROFIBUS and PROFINET products".

For all products that are placed in circulation by **March 19, 2023** the certificate is valid for life.

Karlsruhe, May 14, 2020

Board of PROFIBUS Nutzerorganisation e. V.

 (Official in Charge)

 (Karsten Schneider)



 (Dr. Jörg Hähnliche)

Illustration 2: PROFINET IO/PROFIsafe Certificate



e30b949.10

Danfoss A/S

DK-6430 Nordborg
Denmark
CVR nr.: 20 16 57 15

Telephone: +45 7488 2222
Fax: +45 7449 0949

EU DECLARATION OF CONFORMITY

Danfoss A/S
Vacon Ltd

declares under our sole responsibility that the

Product name VACON® Advanced Safety Options to be used in VACON® NXP AC drive
 Product identification OPTBL, OPTBM, OPTBN
 Product safety functions Safe Torque Off, Safe Stop 1, Safe Stop 2, Safe Operating Stop, Safe Brake Control, Safe Limited Speed, Safe Speed Range, Safe Acceleration Range, Safe Speed Monitor, Safe Direction, Safe Maximum Speed, Safe Quick Stop

fulfils all of the relevant safety component requirements of EC Machinery Directive 2006/42/EC.

Covered by this declaration is in conformity with the following directive(s), standard(s) or other normative document(s), provided that the product is used in accordance with our instructions.

- EN ISO 13849-1:2015
Safety of machinery – Safety-related parts of the control systems – Part 1
- EN ISO 13849-2:2012
Safety of machinery – Safety-related parts of the control systems – Part 2
- IEC 61511-1: 2016
Functional safety - Safety instrumented systems for the process industry sector – Part 1
- EN 60204-1:2006
Safety of machinery – Electrical equipment of machines – Part 1
- EN 61800-5-2:2007
Adjustable speed electrical power drive systems – Part 5-2
- IEC 61508:2010
Functional safety of electrical/electronic/programmable electronic safety-related systems – Parts 1-3
- EN 62061:2005
Safety of machinery – Functional safety of safety-related electrical, electronic and programmable electronic control systems

Person authorised to compile the relevant technical documentation: Vacon Ltd, Runsorintie 7, 65380 Vaasa, Finland.

Date & Place 17.2.2017 Vaasa	Issued by Signature Name Title Pekka Alasaari Product Manager, Functional Safety	Date & Place 13.2.2017 Vaasa	Approved by Signature Name Title Timo Kasi VP, Design Center Finland and Italy
------------------------------------	---	------------------------------------	---

Danfoss only vouches for the correctness of the English version of this declaration. In the event of the declaration being translated into any other language, the translator concerned shall be liable for the correctness of the translation.

ID No: DPD01918

Revision No: A

Page 1 of 1

Illustration 3: EC Declaration of Conformity

1.5 Product Overview

The Advanced safety option board is intended to be used for implementing safety functions according to application needs. The option board is intended to be used with the OPTAF STO option board to implement the safety functions and features in VACON[®] NX drives.

The safety functions available with the Advanced safety option board (according to EN IEC 61800-5-2)

- Safe Torque Off (STO)
- Safe Stop 1 (SS1)
- Safe Stop 2 (SS2)
- Safe Operating Stop (SOS)
- Safe Brake Control (SBC)
- Safe Limited Speed (SLS)
- Safe Speed Range (SSR)
- Safe Speed Monitor (SSM)

The manufacturer-specific safety functions

- Safe Maximum Speed (SMS)
- Safe Quick Stop (SQS)

For more information on the safety functions, see chapter Safety functions.

The safe fieldbuses supported by the option board

- PROFIsafe communication over PROFIBUS
- PROFIsafe communication over PROFINET

Communication over PROFIsafe is implemented according to the PROFIdrive on PROFIsafe amendment.

⚠ WARNING ⚠

DESIGNING OF SAFETY SYSTEMS

Designing a safety-related system incorrectly could result in death or serious injury.

- The designing of safety-related systems requires special knowledge and skills.
- Only qualified persons are permitted to install and set up the product.

⚠ WARNING ⚠

RISK ASSESSMENT OF A SAFETY SYSTEM

The use of safety functions provided by the Advanced Safety Option does not in itself ensure safety.

- To make sure that the commissioned system is safe, you must make an overall risk assessment.
- Safety devices like the Advanced safety option board must be correctly incorporated into the entire system.
- The entire system must be designed in compliance with all relevant standards within the field of industry. Standards such as EN 12100 Part 1, Part 2, and ISO 14121-1 provide methods for designing safe machinery and for making a risk assessment.

⚠ CAUTION ⚠

PROTECTION AGAINST CONTAMINATION

For the product to work properly, it must be protected against conductive dust and contaminants.

- For example, install the Advanced Safety Option board in at least an IP54 enclosure.

NOTICE

This guide provides information on the use of the safety functions that the Advanced Safety Option provides. This information is in compliance with accepted practice and regulations at the time of writing. However, the product/system designer is responsible for making sure that the system is safe and in compliance with relevant regulations.

1.6 Terms and Abbreviations

Table 2: Symbols and Abbreviations

Abbreviation	Definition
Admin	The highest user level for accessing the Advanced safety option board functions. Identified via a password.
Acknowledgment	A signal that indicates that a safety function can be deactivated. Valid for safety functions that use manual acknowledgment.
ASM	An asynchronous motor
Continuous mode	Safety function is active as a part of normal operation.
CRC	Cyclic Redundancy Check
CW	Control word
DAT	Device Acknowledgment Time
Diagnostic Coverage (DC)	The coverage of dangerous failures by run-time diagnostics.
EMC	Electromagnetic compatibility
Encoder interface board	An option board that has an encoder interface.
F-Device	A communication peer that can perform the PROFIsafe protocol.
F-Host	A data processing unit that can perform the PROFIsafe protocol and service the "black channel".
FMEA	Failure Mode and Effects Analysis
Critical fault	A fault that causes the option board to enter into a fault state and requires a reboot to be reset.
GSD	Generic Station Description (used with PROFIBUS).
GSDML	General Station Description Markup Language (used with PROFINET).
Hardware Fault Tolerance (HFT)	The number of hardware failures that the safety system can tolerate without the loss of the safety function.
HAT	Host Acknowledgment Time.
High demand mode	Safety functions are performed on demand. The frequency of demand is more than once a year.
HTL	High Threshold Logic. A voltage level definition.
I/O	Input/Output
Low demand mode	Safety functions are performed on demand. The frequency of demand is less than once a year.
MTTF	Mean Time To Failure
OPTAF	An option board that handles the activation of the STO function for the AC drive.
OPTBL, OPTBM, OPTBN	The variants of the Advanced safety option. OPTBL: no encoder interface. OPTBM: with digital pulse type encoder interface board. OPTBN: with Sin/Cos type encoder interface board.
OPTE3/5	Option board that handles the PROFIBUS DP interface.
OPTEA	Option board that handles the PROFINET IO interface.

Abbreviation	Definition
Parameter file	A configuration file that contains the parameters for an Advanced safety option board.
Unverified parameter file	A parameter file that contains parameters that have not been verified by an Advanced safety option board.
Verified parameter file	A parameter file that contains parameters that have been verified and can be used in an Advanced safety option board.
Validated parameter file	A verified parameter file that contains parameters that have been tested and approved in the system.
PFH	Probability of failure per hour. Valid for systems that operate in a high demand mode or continuous mode.
PFH _d	Probability of dangerous failure per hour.
PFD	Probability of failure on demand. The probability that the safety function does not work when requested. Valid for systems that operate in a low demand mode.
PL	Performance Level
PLC	Programmable Logic Controller
PMSM	A permanent magnet synchronous motor
PROFIBUS	Standardized fieldbus protocol for RS-485 communication.
PROFIdrive	A specification for implementing AC drive related behavior over PROFIBUS/ PROFINET.
PROFINET	Standardized fieldbus protocol for Ethernet communication.
PROFIsafe	A safe fieldbus layer that operates over PROFIBUS/PROFINET.
Reached	A safety function that is reached has stopped the drive (safe stopping functions), or reached a safe area for the measured value and monitoring for leaving the area has been activated (safe monitoring functions).
Resettable fault	An error in that can be reset with a reset signal.
Reset (signal)	A signal used to reset the current violations and faults in the drive and/or the Advanced safety option board and to deactivate the STO function after a violation or fault.
SFF	Safe Failure Fraction
Safe monitoring function	A safety function that monitors a specific value, usually speed.
Safe stopping function	A safety function intended to stop the motor.
Safe range	A range where the monitored value can be. Exceeding the limits of a safe range will cause a violation of the safety function.
Safe state	A state of a device or process that should be maintained to avoid dangerous incidents. For the AC drive system, the safe state is defined as activated STO function.
Service	A user level for accessing the Advanced safety option board functions. Identified via a password. In this user level, it is not possible to verify a parameter file or change passwords.
SFRT	Safety Function Response Time
SRP/CS	Safety-Related Part of a Control System

Abbreviation	Definition
STO	Safe Torque Off. A safety function according to EN IEC 61800-5-2.
SS1	Safe Stop 1. A safety function according to EN IEC 61800-5-2.
SS2	Safe Stop 2. A safety function according to EN IEC 61800-5-2.
SQS	Safe Quick Stop. A manufacturer-specific safety function. Used as a violation response for safe monitoring functions. Parameterizable to behave as the STO, SS1 or SS2 function.
SQS-STO, SQS-SS1, SQS-SS2	Used to indicate the STO, SS1 or SS2 function as the selected behavior of the SQS function.
SLS	Safe Limited Speed. A safety function according to EN IEC 61800-5-2.
SSR	Safe Speed Range. A safety function according to EN IEC 61800-5-2.
SSM	Safe Speed Monitor. A safety function according to EN IEC 61800-5-2.
SMS	Safe Maximum Speed. A manufacturer-specific safety function.
SBC	Safe Brake Control. A safety function according to EN IEC 61800-5-2.
SOS	Safe Operating Stop. A safety function according to EN IEC 61800-5-2.
SIL	Safety Integrity Level
SW	Status word
TTL	Transistor-Transistor Logic. A voltage level definition.
Violation	A fault caused by a safety function detecting a violation of the monitored value(s). The value monitored by a safety function has exceeded the set limit for that value.
Violation response	A reaction to a violation. It is the STO function for the safe stopping functions, and the SQS function for the safe monitoring functions.
WCDT	Worst Case Delay Time
WDTIME	Watchdog Time

2 Safety

2.1 Safety Symbols

The following symbols are used in this manual:

⚠ D A N G E R ⚠

Indicates a hazardous situation which, if not avoided, will result in death or serious injury.

⚠ W A R N I N G ⚠

Indicates a hazardous situation which, if not avoided, could result in death or serious injury.

⚠ C A U T I O N ⚠

Indicates a hazardous situation which, if not avoided, could result in minor or moderate injury.

N O T I C E

Indicates information considered important, but not hazard-related (for example, messages relating to property damage).

2.2 Danger and Warnings

⚠ D A N G E R ⚠

SHOCK HAZARD FROM POWER UNIT COMPONENTS

The power unit components are live when the drive is connected to mains. A contact with this voltage can lead to death or serious injury.

- Do not touch the components of the power unit when the drive is connected to mains. Before connecting the drive to mains, make sure that the covers of the drive are closed.

⚠ D A N G E R ⚠

SHOCK HAZARD FROM TERMINALS

The motor terminals U, V, W, the brake resistor terminals, or the DC terminals are live when the drive is connected to mains, also when the motor does not operate. A contact with this voltage can lead to death or serious injury.

- Do not touch the motor terminals U, V, W, the brake resistor terminals, or the DC terminals when the drive is connected to mains. Before connecting the drive to mains, make sure that the covers of the drive are closed.

⚠ D A N G E R ⚠

SHOCK HAZARD FROM DC LINK OR EXTERNAL SOURCE

The terminal connections and the components of the drive can be live 5 minutes after the drive is disconnected from the mains and the motor has stopped. Also the load side of the drive can generate voltage. A contact with this voltage can lead to death or serious injury.

- Before doing electrical work on the drive:
 - Disconnect the drive from the mains and make sure that the motor has stopped.
 - Lock out and tag out the power source to the drive.
 - Make sure that no external source generates unintended voltage during work.
 - Wait 5 minutes before opening the cabinet door or the cover of the AC drive.
 - Use a measuring device to make sure that there is no voltage.

⚠ WARNING ⚠

SHOCK HAZARD FROM CONTROL TERMINALS

The control terminals can have a dangerous voltage also when the drive is disconnected from mains. A contact with this voltage can lead to injury.

- Make sure that there is no voltage in the control terminals before touching the control terminals.

⚠ WARNING ⚠

ACCIDENTAL MOTOR START

When there is a power-up, a power break, or a fault reset, the motor starts immediately if the start signal is active, unless the pulse control for Start/Stop logic is selected. If the parameters, the applications or the software change, the I/O functions (including the start inputs) can change. If you activate the auto reset function, the motor starts automatically after an automatic fault reset. See the Application Guide. Failure to ensure that the motor, system, and any attached equipment are ready for start can result in personal injury or equipment damage.

- Disconnect the motor from the drive if an accidental start can be dangerous. Make sure that the equipment is safe to operate under any condition.

⚠ WARNING ⚠

LEAKAGE CURRENT HAZARD

Leakage currents exceed 3.5 mA. Failure to ground the drive properly can result in death or serious injury.

- Ensure the correct grounding of the equipment by a certified electrical installer.

⚠ WARNING ⚠

SHOCK HAZARD FROM PE CONDUCTOR

The drive can cause a DC current in the PE conductor. Failure to use a residual current-operated protective (RCD) device Type B or a residual current-operated monitoring (RCM) device can lead to the RCD not providing the intended protection and therefore can result in death or serious injury.

- Use a type B RCD or RCM device on the mains side of the drive.

2.3 Cautions and Notices

⚠ CAUTION ⚠

DAMAGE TO THE AC DRIVE FROM INCORRECT MEASUREMENTS

Doing measurements on the AC drive when it is connected to mains can damage the drive.

- Do not do measurements when the AC drive is connected to mains.

⚠ CAUTION ⚠

DAMAGE TO THE AC DRIVE FROM INCORRECT SPARE PARTS

Using spare parts that are not from the manufacturer can damage the drive.

- Do not use spare parts that are not from the manufacturer.

⚠ CAUTION ⚠

DAMAGE TO THE AC DRIVE FROM INSUFFICIENT GROUNDING

Not using a grounding conductor can damage the drive.

- Make sure that the AC drive is always grounded with a grounding conductor that is connected to the grounding terminal that is identified with the PE symbol.

! CAUTION !**CUT HAZARD FROM SHARP EDGES**

There can be sharp edges in the AC drive that can cause cuts.

- Wear protective gloves when mounting, cabling, or doing maintenance operations.

! CAUTION !**BURN HAZARD FROM HOT SURFACES**

Touching surfaces, which are marked with the 'hot surface' sticker, can result in injury.

- Do not touch surfaces which are marked with the 'hot surface' sticker.

NOTICE**DAMAGE TO THE AC DRIVE FROM STATIC VOLTAGE**

Some of the electronic components inside the AC drive are sensitive to ESD. Static voltage can damage the components.

- Remember to use ESD protection always when working with electronic components of the AC drive. Do not touch the components on the circuit boards without proper ESD protection.

NOTICE**DAMAGE TO THE AC DRIVE FROM MOVEMENT**

Movement after installation can damage the drive.

- Do not move the AC drive during operation. Use a fixed installation to prevent damage to the drive.

NOTICE**DAMAGE TO THE AC DRIVE FROM INCORRECT EMC LEVEL**

The EMC level requirements for the AC drive depend on the installation environment. An incorrect EMC level can damage the drive.

- Before connecting the AC drive to the mains, make sure that the EMC level of the AC drive is correct for the mains.

NOTICE**RADIO INTERFERENCE**

In a residential environment, this product can cause radio interference.

- Take supplementary mitigation measures.

NOTICE**MAINS DISCONNECTION DEVICE**

If the AC drive is used as a part of a machine, the machine manufacturer must supply a mains disconnection device (refer to EN 60204-1).

NOTICE**MALFUNCTION OF FAULT CURRENT PROTECTIVE SWITCHES**

Because there are high capacitive currents in the AC drive, it is possible that the fault current protective switches do not operate correctly.

N O T I C E

VOLTAGE WITHSTAND TESTS

Doing voltage withstand tests can damage the drive.

- Do not do voltage withstand tests on the AC drive. The manufacturer has already done the tests.

2.4 Grounding

Ground the AC drive in accordance with applicable standards and directives.

⚠ C A U T I O N ⚠

DAMAGE TO THE AC DRIVE FROM INSUFFICIENT GROUNDING

Not using a grounding conductor can damage the drive.

- Make sure that the AC drive is always grounded with a grounding conductor that is connected to the grounding terminal that is identified with the PE symbol.

⚠ W A R N I N G ⚠

LEAKAGE CURRENT HAZARD

Leakage currents exceed 3.5 mA. Failure to ground the drive properly can result in death or serious injury.

- Ensure the correct grounding of the equipment by a certified electrical installer.

The standard EN 61800-5-1 tells that 1 or more of these conditions for the protective circuit must be true.

The connection must be fixed.

- The protective earthing conductor must have a cross-sectional area of minimum 10 mm² Cu or 16 mm² Al. OR
- There must be an automatic disconnection of the mains, if the protective earthing conductor breaks. OR
- There must be a terminal for a second protective earthing conductor in the same cross-sectional area as the first protective earthing conductor.

Cross-sectional area of the phase conductors (S) [mm ²]	The minimum cross-sectional area of the protective earthing conductor in question [mm ²]
$S \leq 16$	S
$16 < S \leq 35$	16
$35 < S$	S/2

The values of the table are valid only if the protective earthing conductor is made of the same metal as the phase conductors. If this is not so, the cross-sectional area of the protective earthing conductor must be determined in a manner that produces a conductance equivalent to that which results from the application of this table.

The cross-sectional area of each protective earthing conductor that is not a part of the mains cable or the cable enclosure, must be a minimum of:

- 2.5 mm² if there is mechanical protection, and
- 4 mm² if there is not mechanical protection. With cord-connected equipment, make sure that the protective earthing conductor in the cord is the last conductor to be interrupted, if the strain-relief mechanism breaks.

Obey the local regulations on the minimum size of the protective earthing conductor.

N O T I C E

MALFUNCTION OF FAULT CURRENT PROTECTIVE SWITCHES

Because there are high capacitive currents in the AC drive, it is possible that the fault current protective switches do not operate correctly.

NOTICE**VOLTAGE WITHSTAND TESTS**

Doing voltage withstand tests can damage the drive.

- Do not do voltage withstand tests on the AC drive. The manufacturer has already done the tests.

⚠ WARNING ⚠**SHOCK HAZARD FROM PE CONDUCTOR**

The drive can cause a DC current in the PE conductor. Failure to use a residual current-operated protective (RCD) device Type B or a residual current-operated monitoring (RCM) device can lead to the RCD not providing the intended protection and therefore can result in death or serious injury.

- Use a type B RCD or RCM device on the mains side of the drive.

3 Overview of the System

3.1 Using the Advanced Safety Options

The Advanced safety option board is used to implement safety functions in accordance with the standard EN IEC 61800-5-2. The option board handles the safe I/O and the monitoring of active safety functions. The option board does not handle the control of the AC drive. The AC drive can be controlled, for example, with the drive application, or the external process control system can give the speed reference to the AC drive.

The Advanced safety option board must be used with a subsystem that provides the STO function, it is not possible to use the Advanced safety option board alone. The STO function is provided, for example, by the OPTAF STO option board. To use the safety functions that do speed monitoring, an external speed sensor is necessary. The sensor can be a digital or an analog encoder or a digital proximity sensor. See chapter Speed Measurement.

The Advanced safety option board can be used with the digital I/O and over safe fieldbus. Using a safe fieldbus allows you to control more safety functions than is possible with the limited number of inputs and outputs that the Advanced safety option board has.

When using a safe fieldbus, install an option board that supports the fieldbus. See [7.1.1 Introduction to PROFIsafe](#).

The [Illustration 4](#) shows the configuration of the AC drive with the Advanced safety option board in slot C. The safe fieldbus and the closed-loop control are optional. The possible configuration and available features can depend on other option boards and their installation slots. For use cases with other encoder board installed in slot C, see [3.6.4 Encoders](#).

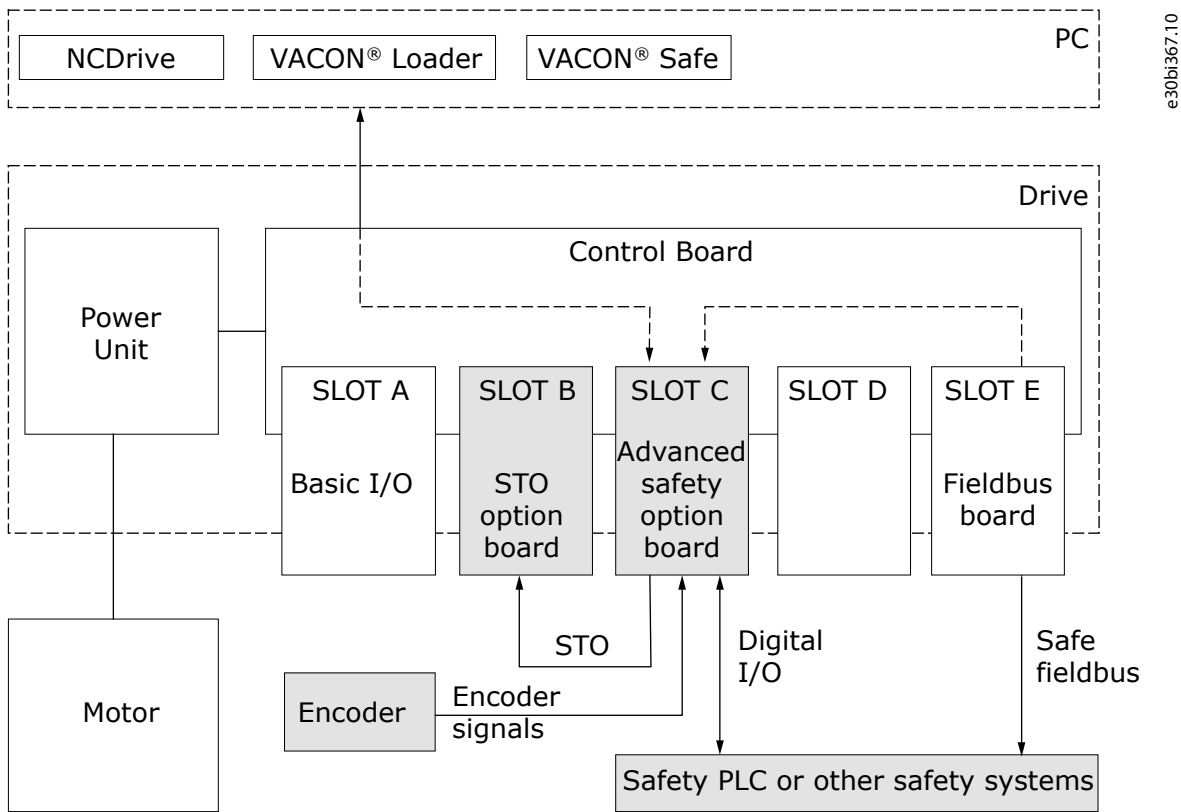

e30bi367.10

Illustration 4: An example configuration of the VACON®NXP drive with the Advanced safety option board. The subsystems that handle safety actions are marked in gray.

The parameterization of the option board is done by selecting and editing the safety functions and features with the VACON®Safe tool. See [5.4 Setting the Parameters](#) and chapter Parameter List.

3.2 The Safe State

There must be a safe state to which the system can be set when necessary. Usually the safe state is reached when the AC drive does not generate torque to the motor shaft. In the Advanced safety option board, this is realized by the Safe Torque Off (STO) safety function.

In some systems, the active STO function in the AC drive does not create a safe state. It means that external forces can generate torque to the motor shaft and cause it to rotate. To achieve the safe state in these systems, additional means are necessary. For example, it is possible to use the STO function and a mechanical brake. The brake can be used with the Safe Brake Control (SBC) safety function of the Advanced option board, or with another safe control system for the brake.

The Advanced safety option board forces the AC drive to the safe state, for example, if there is an error detected in the safety system. Other situations when the safe state is enforced are, for example, the parameterization phase and during the start-up of the drive.

3.3 Integration and Interfaces to Other Systems

When the Advanced safety option board is integrated to a safety system, the system designer and/or the operator is responsible for these things:

- Making an initial system-level risk assessment and reassessing the system any time a change is made.
- The setup and suitability of parameters, sensors, and actuators used in the system.
- Validation of the system to the correct safety level.
- Maintenance and periodic testing.
- Controlling the access to the system, including password handling.

External systems can collect information from the Advanced safety option board in a few different ways.

The option board related fault and violation information is available in the fault log of the AC drive like other faults. This data must be interpreted differently to the fault data of the AC drive. See chapter Fault tracing.

The option board has configurable outputs where desired information can be set to be sent to external systems.

The status data can be received over a safe fieldbus.

3.4 Determining the Achieved Safety Level

⚠ W A R N I N G ⚠

SAFETY AWARENESS IN DESIGN

This chapter is an example and contains simplifications. Using only this data in designing the system can damage the equipment.

- Do not use this chapter as a template for designing your system.
- Perform the design work carefully.

The achieved safety level depends on the whole safety chain. The AC drive with integrated safety functions is only one component in the safety chain.

The things related to the AC drive that affect the achieved safety level:

- The used speed measurement combination.
- The implementation of the violation response and of the fault response. In most cases it is realized via the STO option board (the OPTAF option board for the VACON[®] NX products).

The components of the safety chain that affect the achieved safety level:

- The controllers (for example, the safety PLC) that control the safety functions
- The stop switches
- The wiring

EXAMPLE

Implementation of the STO safety function, consisting of these subsystems.

- Emergency stop switch: Pilz PIT es Set/1-family using two N/C contacts. $B10_d = 104\ 000$ (EN ISO 13849-1) and $\lambda_d / \lambda = 0.20$ (EN IEC 62061) for one channel.
- The OPTAF option board, version VB00328H (141L7786). A two-channel STO option board for the NX family.
- The Advanced safety option board OPTBL.

N O T I C E

Check the corresponding product guides for the safety values and usage instructions.

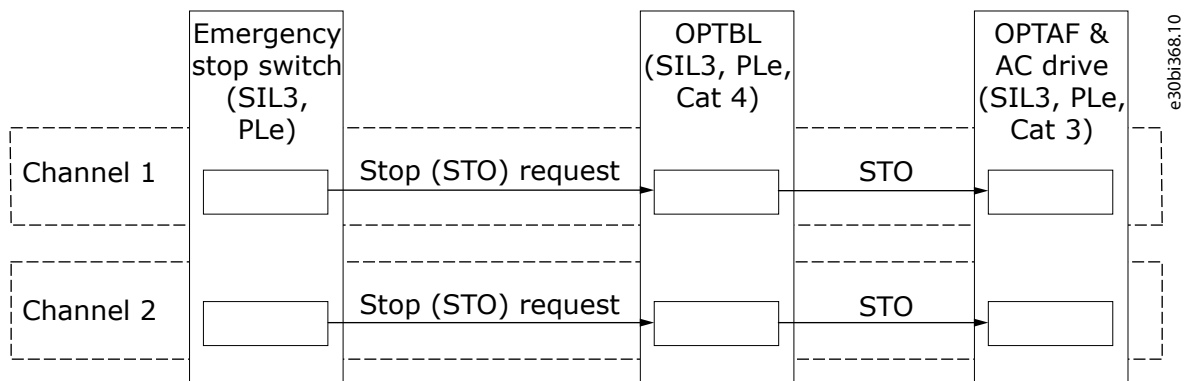

Illustration 5: A Logical Presentation of the STO Safety Function

In this example case, the STO function has one activation per day, and a lifetime of 20 years. For the emergency stop switch, $\beta = 10\%$ is used as the susceptibility to common cause failure between the channels. No proof test is executed during the lifetime. The example system is limited to Category 3 because the Category 3 element OPTAF option board is used as a single final element.

Table 3: An Example of System Level Calculations for the STO Safety Function

Subsystem	SIL, PL	PFH _d	PFD _{avg}	DC _{avg} [%]	MTTF _d [a]
Emergency stop switch	SIL3, PLe	$4.2 \times 10^{-9(1)}$	$3.7 \times 10^{-4(2)}$	90 ⁽³⁾	2849.3 ⁽⁴⁾⁽⁴⁾
OPTBL	SIL3, PLe	6.45×10^{-11}	5.61×10^{-6}	99	373
OPTAF	SIL3, PLe	2.7×10^{-9}	1.3×10^{-4}	60 ⁽⁵⁾	1918
Overall safety system (for STO)	SIL3, PLe	$6.94 \times 10^{-9(6)}$	$5.06 \times 10^{-4(7)}$	74 ⁽⁸⁾	281 ⁽⁹⁾

¹ This value is calculated directly from the values provided by the manufacturer. The diagnostic capabilities of OPTBL have not been taken into account. The calculation formula: $PFH_d = (1 - \beta)^2 \times \lambda_{ch1} \times \lambda_{ch2} \times T_1 + \beta \times (\lambda_{ch1} + \lambda_{ch2}) / 2$, where $\lambda_{ch} = (0.1 \times \text{cycles per hour}) / B10_d$.

² The calculation formula: $PFD_{avg} = (PFH_d \times T_M) / 2$.

³ The OPTBL executes "Cross monitoring of inputs without dynamic test", DC: 0%...99%, depending on how often a signal change is done by the application. A DC of 90% is assumed with the once a day activation.

⁴ The calculation formula: $MTTF_d = B10_d / (0.1 \times \text{cycles per year})$.

⁵ OPTAF manual: DC_{avg} = low, using the lower end of the possible range (60%...90%)

⁶ Sum of the individual PFH_d values.

⁷ Sum of the individual PFH_{avg} values.

⁸ The calculation formula:

$$DC_{avg\ STO} = \frac{\frac{DC_{Switch}}{MTTF_d\ Switch} + \frac{DC_{OPTBL}}{MTTF_d\ OPTBL} + \frac{DC_{OPTAF}}{MTTF_d\ OPTAF}}{\frac{1}{MTTF_d\ Switch} + \frac{1}{MTTF_d\ OPTBL} + \frac{1}{MTTF_d\ OPTAF}}$$

⁹ According to EN ISO 13849-1, the MTTF_d must be limited to a maximum limit of 100 years per channel. The calculation formula:

$$MTTF_d\ STO = \frac{1}{\frac{1}{MTTF_d\ Switch} + \frac{1}{MTTF_d\ OPTBL} + \frac{1}{MTTF_d\ OPTAF}}$$

NOTICE

When designing systems according to IEC-61508, the requirement for the value of the Safe Failure Fraction (SFF) is considered on subsystem level, not on system level.

3.5 Advanced Safety Option Variants

3.5.1 General Information

Newer versions of the Advanced Safety Option have extended slot compatibility. The table [Table 4](#) describes the supported slots for different revisions of the option board. The compatibility is determined by the revision of the board 70CVB01938 (141X4588). See [Illustration 6](#) for the location of the revision information.

Table 4: Supported Slots of the Revisions of the Option Board

Option board revision (70CVB01938, 141X4588)	Slot C	Slot D	Slot E
C, E	-	Yes	-
F	Yes	Yes	Yes

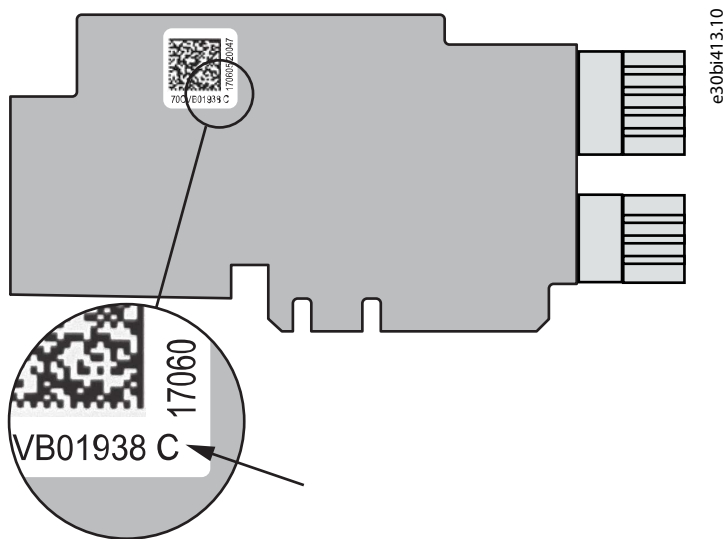

Illustration 6: The Board Identification Sticker on the Advanced Safety Option Board

The Advanced safety option board contains a safe digital I/O for the control and status word signals.

The available connectors of the Advanced safety option board

- 4 two-terminal digital inputs
- 2 two-terminal digital outputs
- 2 STO outputs
- +24 V supply
- GND

It is possible to use the digital inputs for selecting ramps and for activating, acknowledging, and resetting safety functions. The two-terminal digital outputs can be used as output signals of the SBC or the SSM function, or configured by combining various signals of the option board.

If a connected device is powered by an external power supply, make sure that there is common ground between the device and the Advanced safety option board.

NOTICE

The digital outputs use internal diagnostic test pulses to make sure that the output logic operates correctly. These test pulses are visible to external systems. See [11.2 Safe Input/Output Data](#).

3.5.2 Input Configuration

The 4 two-terminal digital inputs operate in a two-terminal equivalent mode: the state of both terminals must match each other within a discrepancy time (see [11.2 Safe Input/Output Data](#)).

Table 5: The Input States

Input terminal A	Input terminal B	State
Active	Active	The assigned safety function is not requested.
Active	Inactive	The assigned safety state is requested. If longer than 500 ms: the option board detects a fault.
Inactive	Active	The assigned safety state is requested. If longer than 500 ms: the option board detects a fault.
Inactive	Inactive	The assigned safety function is requested.

It is possible to assign these tasks to each of the digital inputs:

- the request of a safety function
- the acknowledgment signal
- the reset signal
- the proximity sensor

It is possible to assign 1 task per digital input. The exceptions are the acknowledgment signal and the reset signal which can be assigned to the same input.

N O T I C E

If proximity sensors are used, it is not possible to assign safety function features to the corresponding inputs. See [3.6.5 Proximity sensors](#).

3.5.3 Output Configuration

The 2 two-terminal digital outputs operate in a two-terminal equivalent mode: the state of both terminals must match each other within a discrepancy time (see [11.2 Safe Input/Output Data](#)). The external system or systems should make sure that the two terminals are in the same state.

The tasks that can be assigned to each of the digital outputs:

- the SSM function output
- the SBC function output
- simple custom logic

For more information on the SSM and the SBC function outputs, see [6.2.2.3 The STO Function Used with the SBC Function](#) and [6.3.5.3 The SSM Safe Output](#).

To configure the simple custom logic for an output, select a logical function and desired signals from a configuration group. The option board uses the selected signals and applies the selected logical function to determine the state of the output.

1. Select the group that contains the desired signal or signals.
2. Select the logical function to combine the selected signals.
3. Select the signal or signals.

If only 1 signal is selected: AND or OR (regardless of which): output = signal. NAND or NOR (regardless of which): output = negative signal.

See the examples below for signal and output correspondence.

The available logical functions:

- AND
- OR
- NAND
- NOR

Only 1 logical function per output can be selected.

Table 6: The Available Signals in Configuration Groups

Group 1 and Group 5	Group 2 and Group 6	Group 3 and Group 7	Group 4 and Group 8
STO Reached SS1 Reached SS2 Reached SQS Reached SOS Reached SBC Reached STO and SBC Reached	SLS 1 Reached SLS 2 Reached SLS 3 Reached SSR Reached SMS Reached SSM Reached SSM Above Max Limit SSM Below Min Limit	STO Active SS1 Active SS2 Active SQS Active SLS 1 Active SLS 2 Active SLS 3 Active SSR Active SMS Active SSM Active	Warning in any safety function Limit violation fault in any safety function

During operation, the option board uses the selected signals and applies the selected logical function to determine the state of the output. If the result of the logical function on the actual state of the selected signals is "true", the output is active. If the result is "false", the output is inactive.

EXAMPLE 1 (USING GROUP 2):

Selected signals: SLS 1 Reached, SSM Below Min Limit
Logical function: OR

Table 7: Example 1

State of the signals	Result of the logical function	State of the output
SLS 1 Reached = 0 SSM Below Min Limit = 0	0 OR 0 -> false	Inactive
SLS 1 Reached = 0 SSM Below Min Limit = 1 or SLS 1 Reached = 1 SSM Below Min Limit = 0	0 OR 1 -> true	Active
SLS 1 Reached = 1 SSM Below Min Limit = 1	1 OR 1 -> true	Active

EXAMPLE 2 (USING GROUP 2):

Selected signals: SLS 1 Reached
Logical function: NOR

Table 8: Example 2

State of the signals	Result of the logical function	State of the output
SLS 1 Reached = 0	0 NOR 0 -> true	Active
-	-	-
SLS 1 Reached = 1	1 NOR 1 -> false	Inactive

EXAMPLE 3 (USING GROUP 2):

Selected signals: SLS 1 Reached, SSM Below Min Limit
Logical function: AND

Table 9: Example 3

State of the signals	Result of the logical function	State of the output
SLS 1 Reached = 0 SSM Below Min Limit = 0	0 AND 0 -> false	Inactive
SLS 1 Reached = 0 SSM Below Min Limit = 1 or SLS 1 Reached = 1 SSM Below Min Limit = 0	0 AND 1 -> false	Inactive
SLS 1 Reached = 1 SSM Below Min Limit = 1	1 AND 1 -> true	Active

EXAMPLE 4 (USING GROUP 2):

Selected signals: SLS 1 Reached, SSM Below Min Limit

Logical function: NAND

Table 10: Example 4

State of the signals	Result of the logical function	State of the output
SLS 1 Reached = 0 SSM Below Min Limit = 0	0 NAND 0 -> true	Active
SLS 1 Reached = 0 SSM Below Min Limit = 1 or SLS 1 Reached = 1 SSM Below Min Limit = 0	0 NAND 1 -> true	Active
SLS 1 Reached = 1 SSM Below Min Limit = 1	1 NAND 1 -> false	Inactive

3.5.4 Option Board OPTBL

Use the Advanced safety option board OPTBL when no encoder is used to measure the speed of the motor shaft.

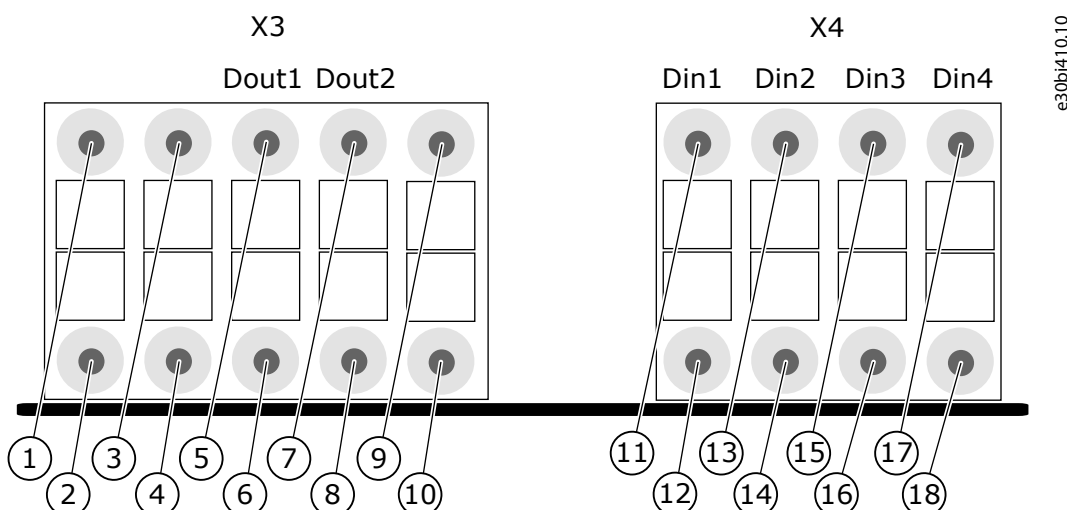

Illustration 7: The Terminals X3 and X4 of the OPTBL Option Board

1	STO 1. STO terminal 1 +24 V, to be connected to OP-TAF terminal SD1+.	10	GND.
2	STO 2. STO terminal 2 +24 V, to be connected to OP-TAF terminal SD2+.	11	Din 1A. Terminal A of digital input 1.
3	GND.	12	Din 1B. Terminal B of digital input 1.
4	GND.	13	Din 2A. Terminal A of digital input 2.
5	Dout 1A. Terminal A of digital output 1.	14	Din 2B. Terminal B of digital input 2.
6	Dout 1B. Terminal B of digital output 1.	15	Din 3A. Terminal A of digital input 3.
7	Dout 2A. Terminal A of digital output 2.	16	Din 3B. Terminal B of digital input 3.
8	Dout 2B. Terminal B of digital output 2.	17	Din 4A. Terminal A of digital input 4.
9	+24 V. +24 V supply for external logic.	18	Din 4B. Terminal B of digital input 4.

3.5.5 Option Board OPTBM

The OPTBM option board is similar to the OPTBL option board, but in addition, the OPTBM option board has a digital pulse TTL/HTL type encoder interface board attached to it.

The digital pulse type encoder interface board is used to connect encoders with digital signals to the OPTBM option board. The option board supports encoders with Transistor-Transistor Logic (TTL) and High Threshold Logic (HTL) type signals. Make sure that the used type is correctly set during parameterization.

The digital pulse type encoder interface board is designed for HTL encoders with a voltage output type of push-pull.

From revision F onwards, the OPTBM (70CVB01957, 141X4608) board enables the use of closed-loop control. To use closed-loop control, the OPTBM board must be installed in slot C. For further information, see [3.5.7 Closed-loop Control with OPTBM](#).

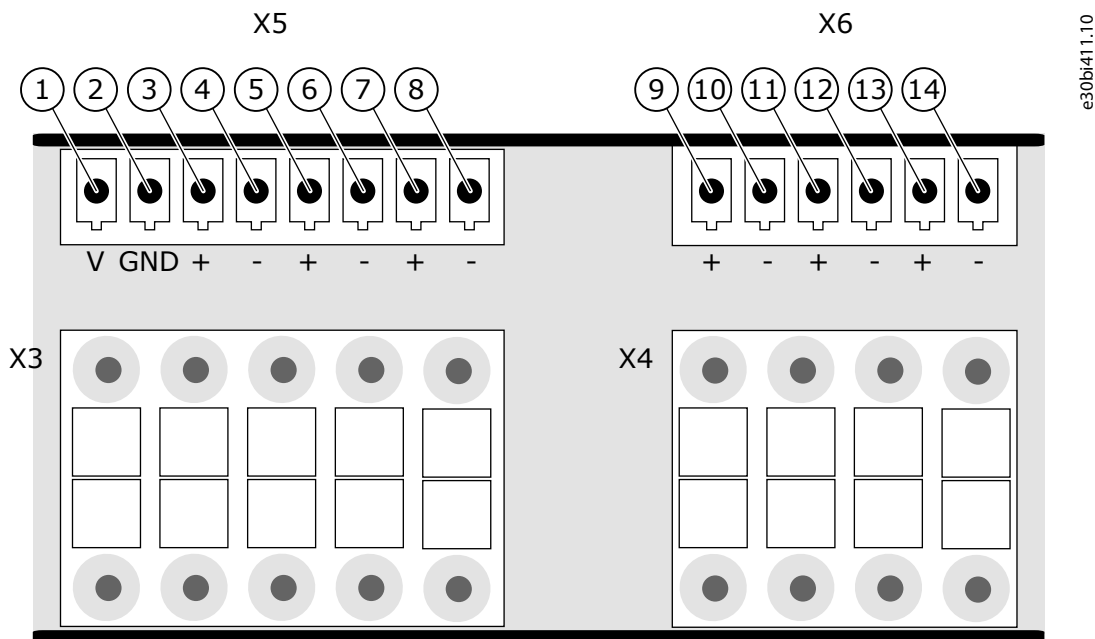

Illustration 8: The Terminals X5 and X6 of the Digital Pulse Type Encoder Interface Board

1	Configurable encoder voltage.	8	Z-. Reference signal, optional.
2	GND.	9	A+. Unmodified encoder signal loopback.
3	A+. Terminal A of digital pulse signal.	10	A-. Unmodified encoder signal loopback.
4	A-. Terminal A of digital pulse signal.	11	B+. Unmodified encoder signal loopback.
5	B+. Terminal B of digital pulse signal.	12	B-. Unmodified encoder signal loopback.
6	B-. Terminal B of digital pulse signal.	13	Z+. Unmodified encoder signal loopback.
7	Z+. Reference signal, optional.	14	Z-. Unmodified encoder signal loopback.

3.5.6 Option Board OPTBN

The OPTBN option board is similar to the OPTBL option board, but in addition, the OPTBN option board has a Sin/Cos type encoder interface board attached to it.

The Sin/Cos type encoder interface board is used to connect an encoder with analog sinus and cosine signal to the OPTBN option board.

From revision E onwards, the OPTBN (70CVB01958, 141X4610) board enables the use of closed-loop control. To use closed-loop control, the OPTBN board must be installed in slot C. For further information, see [3.5.8 Closed-loop Control with OPTBN](#).

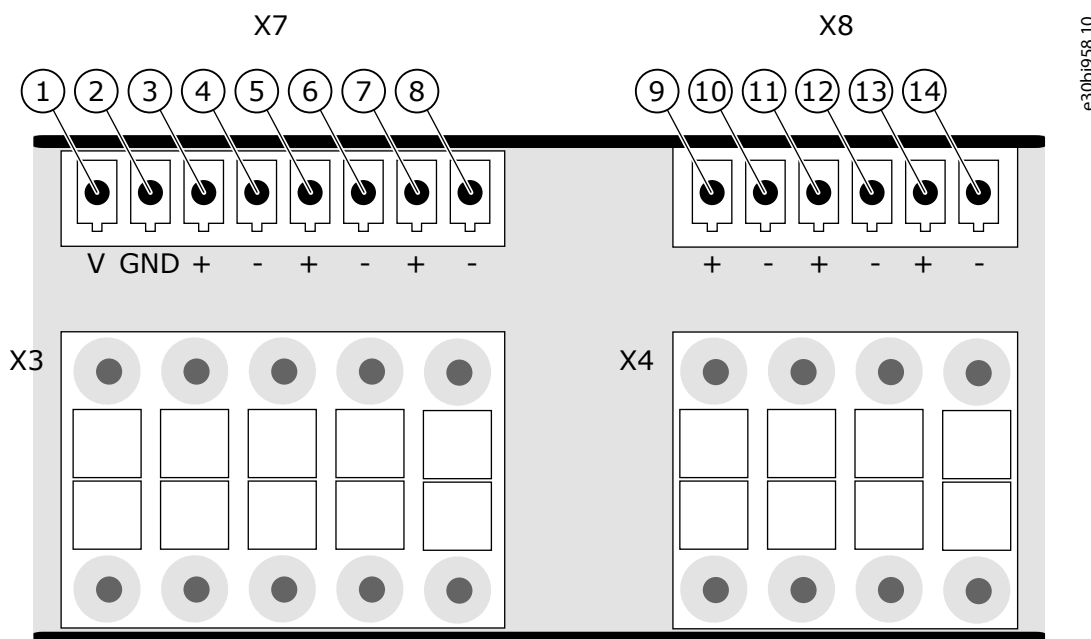

Illustration 9: The Terminals X7 and X8 of the Sin/Cos Type Encoder Interface Board

1	Encoder voltage. Selectable encoder voltage.	8	Z-. Reference signal, optional.
2	GND.	9	Sin+. Unmodified encoder signal loopback.
3	Sin+. Sinus terminal of analog pulse signal.	10	Sin-. Unmodified encoder signal loopback.
4	Sin-. Sinus terminal of analog pulse signal.	11	Cos+. Unmodified encoder signal loopback.
5	Cos+. Cosine terminal of analog pulse signal.	12	Cos-. Unmodified encoder signal loopback.
6	Cos-. Cosine terminal of analog pulse signal.	13	Z+. Unmodified encoder signal loopback.
7	Z+. Reference signal, optional.	14	Z-. Unmodified encoder signal loopback.

3.5.7 Closed-loop Control with OPTBM

The OPTBM board can be used to realize closed-loop control. To use closed-loop control with OPTBM, check that the OPTBM revision supports closed-loop control, and that the OPTBM board is installed in slot C.

When using closed-loop control with OPTBM, consider the following features or differences compared to the other encoder boards used for closed-loop control.

- The value of Pulse/revolution (normally shown as P7.3.1.1) used for closed-loop control is copied from the parameterization of the Advanced Safety Option. It cannot be edited independently.
- The parameter Reading Rate (shown as P7.3.1.3.1) can be edited normally.
- Parameter Invert Direction (normally shown as P7.3.1.2) is not supported or shown. Value "0 = No" is always used.
- Parameter Encoder Type (normally shown as P7.3.1.4) is not supported or shown. Value "1 = A, B = speed" is always used.
- The qualifier input ENC1Q is not included in OPTBM.
- The fast digital input DIC4 is not included in OPTBM.
- The encoder must use differential signals. Single-ended encoders are not supported.

3.5.8 Closed-loop Control with OPTBN

The OPTBN board can be used to realize closed-loop control. To use closed-loop control with OPTBN, check that the OPTBN revision supports closed-loop control, and that the OPTBN board is installed in slot C.

When using closed-loop control with OPTBN, consider the following features or differences compared to the other encoder boards used for closed-loop control.

- The value of Pulse/revolution (normally shown as P7.3.1.1) used for closed-loop control is copied from the parameterization of the Advanced Safety Option. It cannot be edited independently.
- The parameter Reading Rate (shown as P7.3.1.3.1) can be edited normally.
- Parameter Invert Direction (normally shown as P7.3.1.2) is not supported or shown. Value "0 = No" is always used.
- The parameter Interpolation (normally shown as P7.3.1.4) is not supported. Value "0 = No" is always used.

3.6 Speed Measurement

3.6.1 Safety Speed Sensors

The speed measurement methods supported by the Advanced safety option board:

- Sin/Cos encoder
- Digital pulse encoder (TTL or HTL)
- Proximity sensor

For parametric information, see [8.1.3 Speed Measurement Parameters](#).

When certified speed sensors are used, the sensors can be used to implement safety functions up to the safety level stated in the certificate. To use these speed sensors, make sure that the sensor monitoring executed by the option board fulfills the requirements that the sensor has for the speed monitoring device. For the monitoring executed by the Advanced safety option board, see [3.6.6 Encoder Signal Verification](#).

3.6.2 Standard Speed Sensors and Combinations

The speed measurement methods supported by the Advanced safety option board:

- Sin/Cos encoder
- Digital pulse encoder (TTL or HTL)
- Proximity sensor

For parametric information, see [8.1.3 Speed Measurement Parameters](#).

The option board can be used with standard speed sensors. The table below shows the maximum achievable safety levels for combinations of different speed sensors without certificate.

In addition to speed sensors, it is possible to use estimated speed from the control board of the AC drive as a second channel for speed measurement diagnostics.

Calculate and take into account the relevant safety values for the encoder when assessing the fulfillment of the requirements for the targeted safety level(s). The relevant safety values include these values:

- PFH
- Category
- Performance level

For the diagnostic coverage for the encoder, see [3.6.6 Encoder Signal Verification](#).

Table 11: Achievable Safety Levels when Using Speed Sensors without Certificate

Safety function	Sin/Cos	Digital Pulse + estimated speed	2 x Proximity sensor	Proximity sensor + estimated speed	Sin/Cos + proximity sensor	Digital Pulse + proximity sensor	Any other combination
STO (+SBC)	SIL 3, PL _e , Cat4	SIL 3, PL _e , Cat4	SIL 3, PL _e , Cat4	SIL 3, PL _e , Cat4	SIL 3, PL _e , Cat4	SIL 3, PL _e , Cat4	SIL 3, PL _e , Cat4
SS1	SIL 3, PL _e , Cat4	SIL 3, PL _e , Cat4	SIL 3, PL _e , Cat4	SIL 3, PL _e , Cat4	SIL 3, PL _e , Cat4	SIL 3, PL _e , Cat4	SIL 3, PL _e , Cat4
SS2, SOS	SIL 2, PL _d , Cat3	-	-	-	SIL 2, PL _d , Cat3	-	-
SQS-STO	SIL 3, PL _e , Cat4	SIL 3, PL _e , Cat4	SIL 3, PL _e , Cat4	SIL 3, PL _e , Cat4	SIL 3, PL _e , Cat4	SIL 3, PL _e , Cat4	SIL 3, PL _e , Cat4
SQS-SS1	SIL 3, PL _e , Cat4	SIL 3, PL _e , Cat4	SIL 3, PL _e , Cat4	SIL 3, PL _e , Cat4	SIL 3, PL _e , Cat4	SIL 3, PL _e , Cat4	SIL 3, PL _e , Cat4
SQS-SS2	SIL 2, PL _d , Cat3	-	-	-	SIL 2, PL _d , Cat3	-	-
SLS	SIL 2, PL _d , Cat3	SIL 2, PL _d , Cat2	SIL 3, PL _e , Cat4	SIL 2, PL _d , Cat2	SIL 3, PL _e , Cat4	SIL 3, PL _e , Cat4	-
SMS	SIL 2, PL _d , Cat3	SIL 2, PL _d , Cat2 ⁽¹⁾	SIL 3, PL _e , Cat4 ⁽²⁾	SIL 2, PL _d , Cat2 ⁽¹⁾	SIL 3, PL _e , Cat4 ⁽²⁾	SIL 3, PL _e , Cat4 ⁽²⁾	-
SSM	SIL 2, PL _d , Cat3	SIL 2, PL _d , Cat2	SIL 3, PL _e , Cat4	SIL 2, PL _d , Cat2	SIL 3, PL _e , Cat4	SIL 3, PL _e , Cat4	-
SSR	SIL 2, PL _d , Cat3	SIL 2, PL _d , Cat2	SIL 3, PL _e , Cat4	SIL 2, PL _d , Cat2	SIL 3, PL _e , Cat4	SIL 3, PL _e , Cat4	-

¹ Only if the monitored limits to both directions are set to the same value or both values are greater than the value of Allowed Deviation of Speed Sources.

² Only if the monitored limits to both directions are set to the same value.

Table [Table 11](#) gives the maximum SIL, PL, and Cat levels that can be achieved with a combination. Other factors than speed measurement can be the limiting factor on system level. For example, either SIL 2 or SIL 3 can be achieved with the OPTAF STO option board as a single final element. See the VACON® NX OPTAF STO Board Manual for further information.

NOTICE

For non-safe Sin/Cos encoders, it is required in the table [Table 11](#) that the encoder is implemented in analog design. The fault model "Exchange of Sin and Cos signal inside the encoder" must be excluded.

Combinations that are not listed in the table [Table 11](#) are not tested or supported, and offer no increase to the claimed safety levels. It can still be possible to use unlisted combinations. Regardless of the used speed measurement combination, it is the responsibility of the system designer to make sure that the used combination is adequate and sufficient.

NOTICE

When multiple speed sources are used, the monitored limit of a safety function must not be set below the value of Allowed Deviation of Speed Sources.

3.6.3 Speed Discrepancy with Multiple Speed Sources

When you use multiple speed sources, for example, a Sin/Cos encoder and a proximity sensor, or estimated speed and a speed sensor, the speed values measured by these sensors must be within the allowed deviation of each other.

There is new behavior in the software version FW0281 V004: the reaction to exceeding the deviation depends on the request for safety functions. If a safety function is requested, the reaction is a fault and STO will be activated. If no safety function is requested, the reaction is a warning and STO will not be activated. This enables continuing the process and stopping at an acceptable and safe position. It is also possible to start a single drive in already running process where there is a difference in estimated speed and encoder speed before the drive enters run mode, that is, a "flying start" situation.

! CAUTION !

INSUFFICIENT SPEED MEASUREMENT CAPACITY

When the warning for speed difference is active, the safety system cannot guarantee that the speed measuring capability is sufficient.

- Running in this mode should be kept to minimal, for example to only start the motor in "flying start" situation or to continue to a safe position.

If running the motor in this situation cannot be accepted, a possible solution is to use the Safe Speed Monitor (SSM) safety function. It can be set to "Always active" mode. So, the safety function is always requested and the reaction to speed discrepancy is always fault and STO. This is the same as the behavior in the previous software version (FW0281 V003 and older).

The value for the allowed deviation between the speeds can be set during parameterization. A formula for a recommended value with a speed sensor and estimated speed can be found in chapter Estimated speed.

3.6.4 Encoders

The encoder interface boards of the Advanced safety option board have two connector sets. The cables from an encoder are connected to one connector set. The other connector set provides the encoder signals as output that can be connected to other devices that use the encoder data. Such device can be, for example the standard encoder board that is used to realize the closed-loop control. The Advanced safety option board transmits the signals from the encoder to the other connector set without any modification.

NOTICE

When you use speed sensors for the safety functions, it is possible that the AC drive operates in open loop or closed-loop control. When closed-loop control is used, a closed-loop enabling option board must be used in slot C. This can be either a separate encoder board or the Advanced Safety Option.

NOTICE

When you use speed sensors without SIL claims, estimated speed from the AC drive can be used as a second independent channel to fulfill the requirements of safety standards. See chapter Standard Speed Sensors and Combinations.

NOTICE

The encoder signals consist of two separate channels (for example, sinus and cosine). Do not change the order or modify the channels before connecting them to the Advanced safety option.

When the Advanced Safety Option is used for closed-loop control, it must be installed in slot C. Connect the encoder cables to the board normally.

When closed-loop control is used with a separate encoder board, connect the SinCos/Digital pulse signal cables of the encoder to the encoder interface board of the Advanced safety option board. Connect also the encoder interface board to the encoder board in slot C. The encoder board implements the closed-loop control by using the encoder interface board to receive feedback. See the figure below.

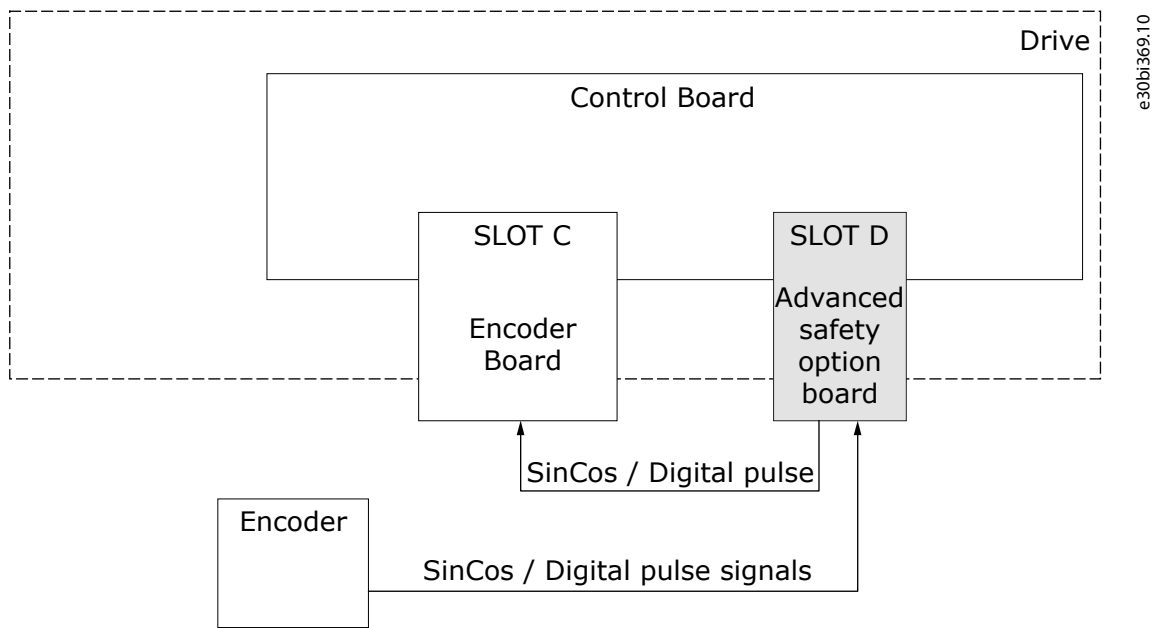

Illustration 10: Encoder Signals in Closed-loop Control

When an absolute encoder is used, the cables for the absolute data are connected directly to the encoder board id slot C. The SinCos/Digital pulse signal cables are connected to the Advanced safety option board and from there to the option board in slot C.

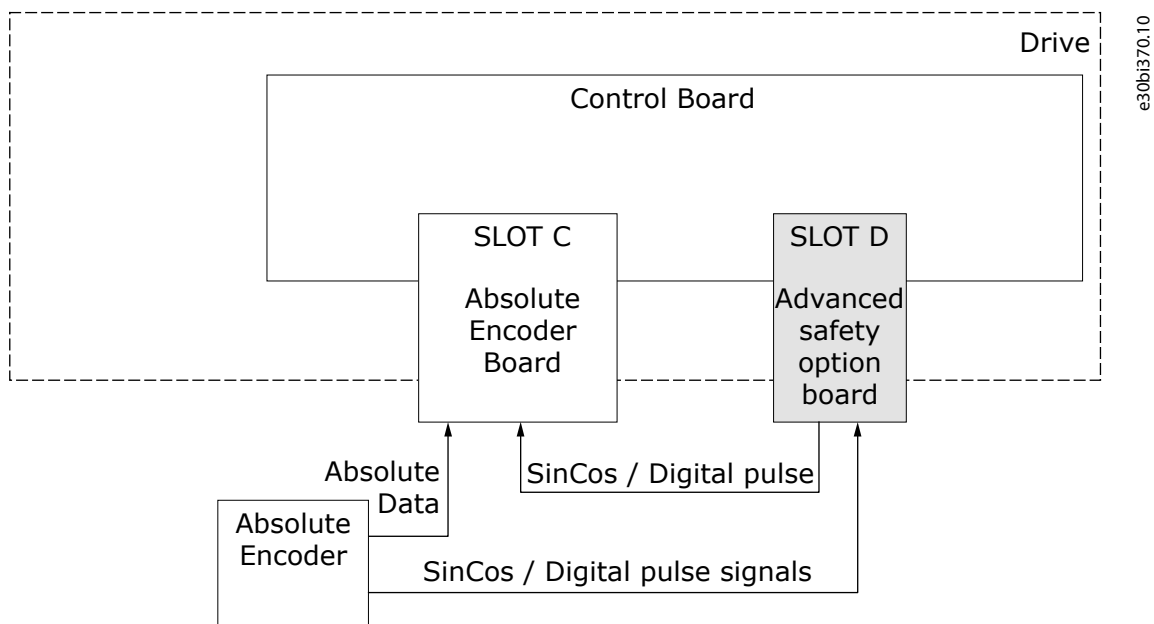

Illustration 11: Absolute Encoder Signals in Closed-loop Control

This configuration enables the use of absolute encoder with position data for control. The safety functions are implemented without the absolute data, and the safety functions with position monitoring are monitoring the relative position based on the incremental signals from the encoder.

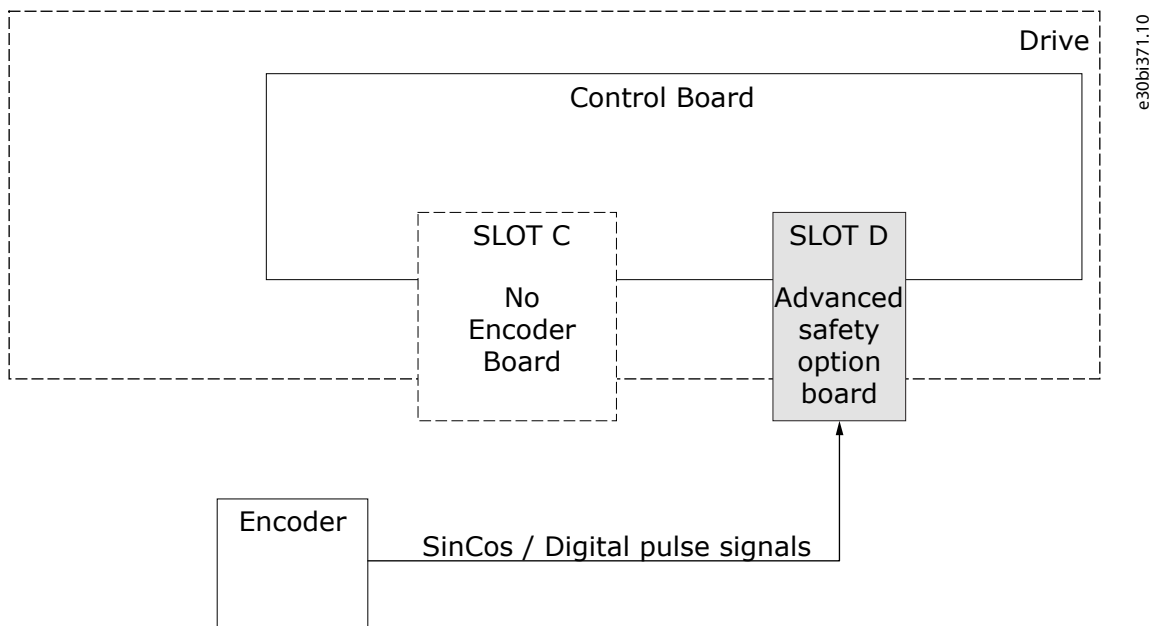

Illustration 12: Open Loop Control without an Encoder Board in Slot C

Because of EMC reasons, the last component that handles the encoder signals should have a termination resistor when Sin/Cos or TTL type encoders are used. The termination resistor enhances the quality of the signals. If there are no components on the encoder signal chain after the Advanced safety option board, the termination must be on the Advanced safety option board.

If the Advanced safety option board transmits the encoder signals to the encoder board in slot C, use termination on the encoder board and not on the Advanced safety option board. This applies to the cases in [Illustration 10](#) and [Illustration 11](#). It also applies to other possible components that handle the encoder signals.

Do not use multiple termination resistors. Configure the termination resistor during the parameterization of the Advanced safety option board.

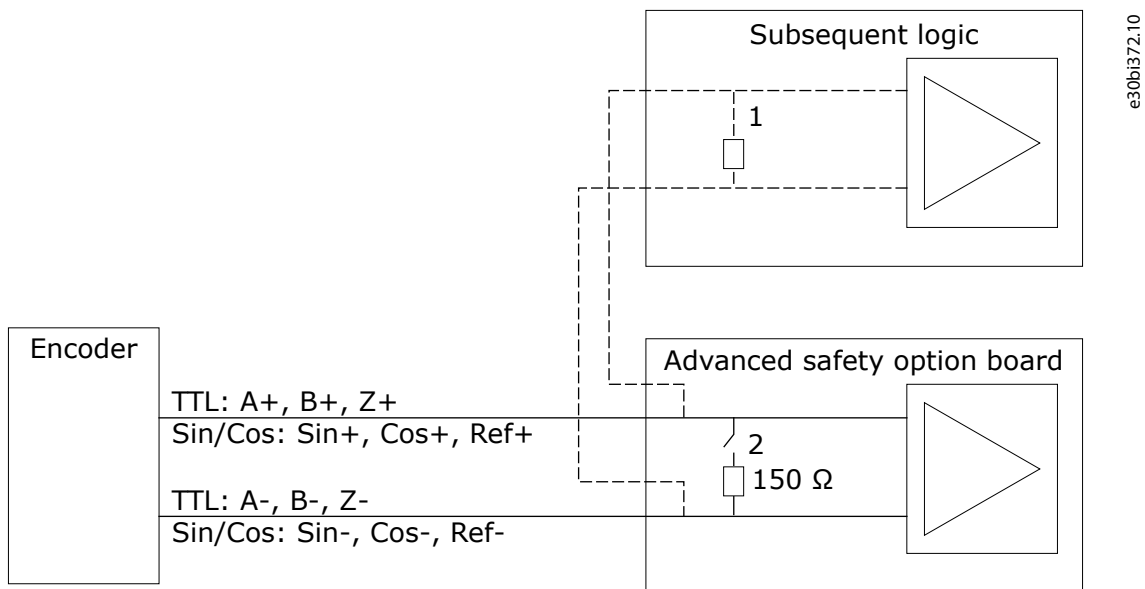

Illustration 13: Using Termination Resistors, Resistor 1 or Resistor 2

The use of resistor on the Advanced safety option board is selected during parameterization.

Table 12: Termination Resistor Usage

Encoder type	Encoder signal loop-back used	Termination resistor on the Advanced safety option board used
TTL or Sin/Cos	No	Yes
TTL or Sin/Cos	Yes	No
HTL	Any	Use of a termination resistor is not required

3.6.5 Proximity sensors

It is possible to connect two proximity sensors to the safe I/O of the Advanced safety option board. The option board supports only the 4-wire PNP type proximity sensors. A proximity sensor must supply two signals, a normal and an inverted signal, to the Advanced safety option board.

When one proximity sensor is used, connect it to the digital input 1 of the safe I/O. If a second proximity sensor is added, connect it to the digital input 2. The two proximity sensors must be installed so that they have the same number of pulses per rotation.

For a proximity sensor connection example, see [13.9 A Proximity Sensor for Speed Measurement](#).

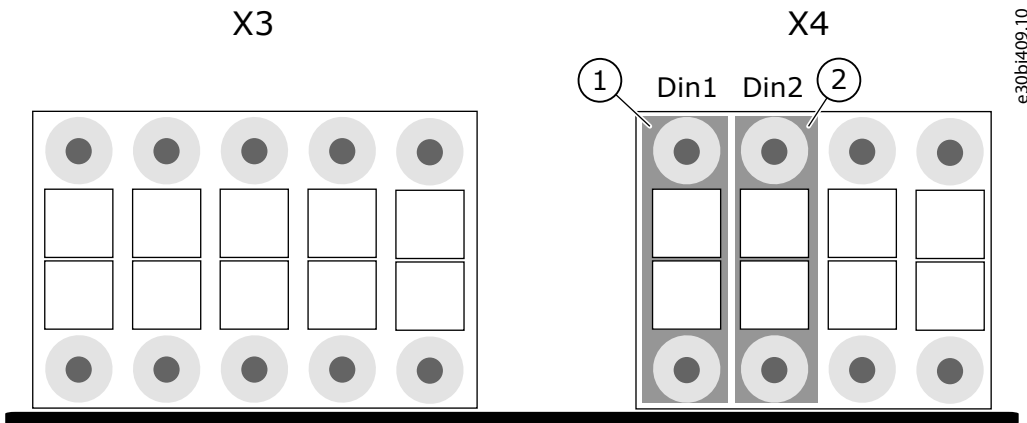

Illustration 14: Connecting Proximity Sensors to the Connectors of the Option Board

- 1 Terminals for the first proximity sensor
- 2 Terminals for the second proximity sensor

The duty cycle (that is, the active-inactive signal ratio) of the proximity sensors is set during the parameterization. Setting the duty cycle to a value other than 50% (1:1 signal ratio) decreases the supported maximum frequency of the proximity sensor signals. The Advanced safety option board does not monitor that the actual duty cycle corresponds to the parametrized value. The duty cycle must be set to an approximately correct value so that the Advanced safety option board can correctly detect when the speed exceeds the supported maximum frequency and trigger a fault. Otherwise the short pulses at high speed may not be detected and the speed measurement may indicate too low a speed.

NOTICE

Use of ramp monitoring is not recommended when only proximity sensors are used as speed sensor.

Due to the way the speed is calculated, it is not recommended to set the safety function speed limits below a certain value. This value depends on the pulses per revolution of the proximity sensor signal. A formula for calculation of the rpm value is $15000/ppr$.

Table 13: Recommended Minimum Limits

Sensor ppr	Minimum recommended speed limits (rpm)
1	15000
4	3750
8	1875
32	469

3.6.6 Encoder Signal Verification

The Advanced safety option board verifies the correctness of the encoder signals. During the operation of the option board, the encoders are supervised.

Supervision of all encoder types

- When two speed sources are used, they are cross-checked against each other.

Supervision of Sin/Cos type encoders

- The amplitude of the encoder signals is monitored to keep it within acceptable limits.
- Making sure that the encoder signals are in valid differential state (for example, Sin+ to Sin-).
- Making sure that the sinus and cosine signals are in phase shift between the different channels.
- The tests of the Sin/Cos encoder are equivalent to $\sin^2(x) + \cos^2(x) = 1$.

Supervision of Digital pulse type encoders

- Making sure that the encoder signals are in valid differential state (for example, A+ to A-).
- Making sure that the signals are in phase shift between the different channels.

Supervision of proximity sensors

- Making sure that the proximity sensor signals are in valid differential state (for example, A+, A-).

Diagnostic coverage for the encoder

- Sin/Cos 99%
- Digital pulse 90%
- Proximity sensor 90%

N O T I C E

In addition to the two differential channels used for speed measurement, a reference signal (also called Zero/Z-pulse) can be used for additional supervision of the correctness of the encoder signals. If the reference signal is parameterized to be used, the total absence of the reference signal will be detected. The disconnection of one of the differential signals might not be detected. In such cases, the additional supervision based on the reference signal is not lost.

The tests are done automatically when the motor rotates. To make sure that the correct operation continues, the motor cannot be kept at standstill for longer than 30 days. In practice, the conditions that are listed below must be valid for the standstill counter to reset.

When estimated speed is used

- Estimated speed is valid (that is, the AC drive is rotating the motor).
- Estimated speed and the speed measured by the encoder are greater than the allowed deviation of the speed sources.

When estimated speed is not used

- The motor must be rotated for at least two revolutions with a speed above 120/k rpm, where k is "encoder number of pulses" or "proximity sensor number of pulses", depending on the used speed sensor. If an encoder and a proximity sensor are used, the calculation must be valid for both.

3.6.7 Usage of Only One Speed Sensor

When a single speed sensor is used, take into account these fault models. To prevent these faults, plan the design and installation of your system carefully. For more information, see the standard.

Table 14: Speed Sensor Fault Models and their Fault Exclusions

Fault model as stated in EN IEC 61800-5-2	Fault exclusion as stated in EN IEC 61800-5-2 (Annex D Table D.16)
A loss of an attachment during motion: <ul style="list-style-type: none"> • sensor housing from motor chassis • sensor shaft from motor shaft • mounting of the readhead 	Prepare the Failure mode and effects analysis (FMEA) and prove: <ul style="list-style-type: none"> • permanent fastness for formlocked connections • fastness for force-locked connections
A loosening of an attachment during motion: <ul style="list-style-type: none"> • sensor housing from motor chassis • sensor shaft from motor shaft • mounting of the readhead 	
A loss of an attachment during standstill: <ul style="list-style-type: none"> • sensor housing from motor chassis • sensor shaft from motor shaft • mounting of the readhead 	

In practice, the solution is over dimensioning against the occurrence of the fault model. The sufficient over dimensioning factor depends on the connection type and the fault model. In case the drive operates in open loop and the estimated speed is also used, cross-check with the estimated speed will detect the fault in the encoder. In closed loop with no external accelerative forces, it is likely that the fault will not be detected. In this case, after the loss of the encoder, the drive will either trigger a fault or the speed of the motor will not accelerate but will stabilize to a speed value that corresponds to the nominal slip of the motor. See also the operating instructions of the encoder.

3.6.8 Estimated Speed

It is recommended to use two standard speed sensors or a single certified speed sensor. When it is not possible, a standard speed sensor can be used with estimated speed measured by the AC drive. The estimated speed is used as a second independent channel to compare against the value of the speed sensor. Estimated speed is used for diagnostics only and it does not trigger safety function limit violation on its own.

Estimated speed can be used with a digital pulse encoder or a proximity sensor. With a Sin/Cos type encoder, the estimated speed offers no benefits because it is limited to SIL2 which an analog Sin/Cos type encoder can fulfill alone.

Estimated speed can be used with these safety functions:

- The STO function
- The SS1 function
- The SQS function (in STO and SS1 mode)
- The SLS function
- The SSR function
- The SSM function
- The SMS function (when the SMS limits have the same value, or when the values of SMS Limit Plus and SMS Limit Minus are greater than the value of Allowed Deviation of Speed Sources)

Estimated speed cannot be used with these safety functions:

- The SS2 function
- The SQS function (in SS2 mode)

N O T I C E

Estimated speed with a speed sensor fulfills the safety requirements, but it is possible that estimated speed is less accurate than a sensor, especially when sudden changes occur in the load or the speed.

⚠ WARNING ⚠

EXTERNAL BRAKES NEEDED

Estimated speed is calculated only when the drive is in RUN state, that is, when the drive is operating.

- If external forces can cause acceleration to the motor when the drive is not in RUN state, use, for example, external brakes to stop the motor and to keep it in standstill.

⚠ WARNING ⚠

OPEN-LOOP CONTROL AND EXTERNAL FORCES

If the drive operates in open-loop control and there are external forces that can cause acceleration to the motor, the drive can pull out (that is, the motor is not under control). This situation can cause estimated speed to be invalid.

⚠ WARNING ⚠

USAGE OF ONLY ONE SPEED SENSOR

If only one encoder is used for safety monitoring and closed-loop control, the fault model detachment of the encoder from the motor shaft must be analyzed.

- Make sure that the fault model detachment of the encoder from the motor shaft is analyzed.
- See [3.6.7 Usage of Only One Speed Sensor](#).

When estimated speed is used, the speed value from an external speed sensor is compared against the calculated value from the AC drive. If the two values differ from each other more than the value of Allowed Deviation of Speed Sources, during a time set with Speed Deviation Timer, a reaction as described in [3.6.3 Speed Discrepancy with Multiple Speed Sources](#) is executed. See [Illustration 15](#).

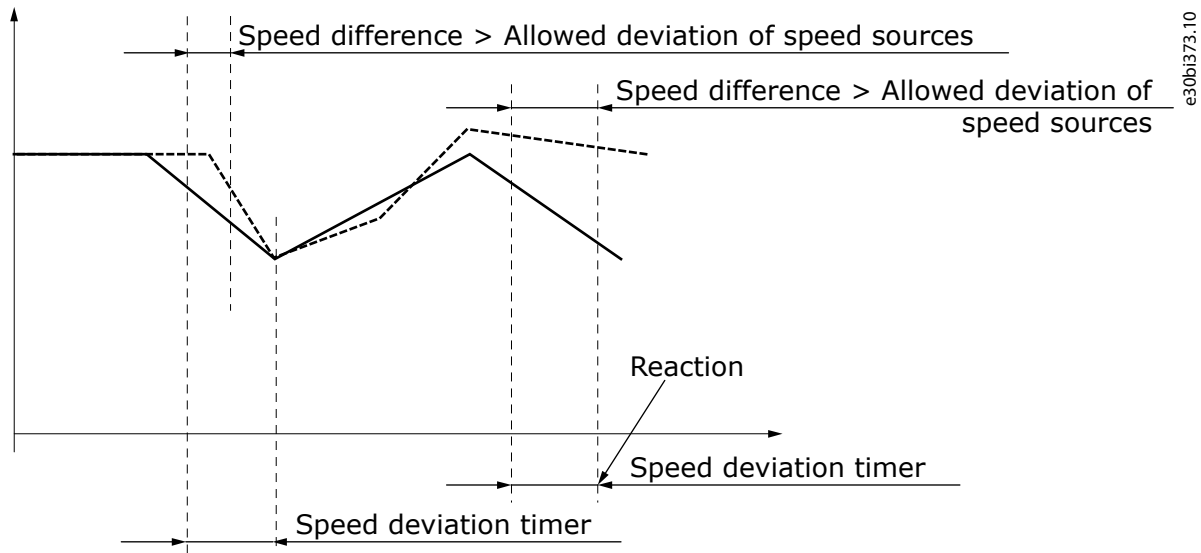
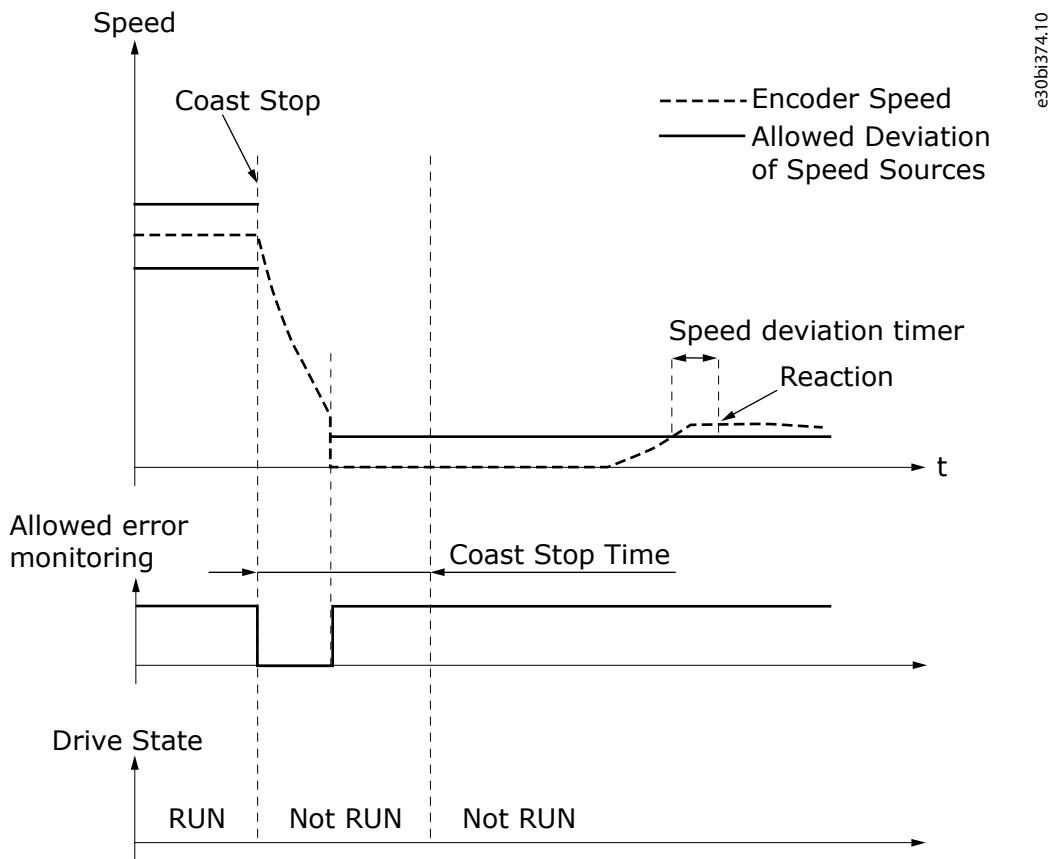

Illustration 15: The speed difference of estimated speed and the speed measured by a sensor does not stay within the set limits and causes a comparison fault

When the AC drive is not in RUN state, estimated speed is not calculated, and the motor is assumed to be coasting to stop. During that time, the comparison between estimated speed and the speed measured by a sensor is not made. The comparison is activated again when the value of Coast Stop Time passes, or once the speed of the encoder goes below the value of Allowed Deviation of Speed Sources. If the speed sensor indicates rotation that is not permitted by Allowed Deviation of Speed Sources, a fault appears. See [Illustration 16](#).



e30bi374.10

Illustration 16: Estimated speed monitoring when the AC drive is not operating. A state "Not RUN" can be caused, for example, by a fault or a stop command given to the AC drive.

To make sure that your system operates correctly and safely, set the value of Allowed Deviation of Speed Sources separately for each application. Use this formula as a starting point to find the optimal value for the parameter. It is possible that the formula does not give correct values with motors that have a large nominal slip, for example small motors or specially designed motors.

The Allowed Deviation of Speed Sources [rpm] =

$$\max\left\{\frac{5}{100} \times \text{Synchronous nominal speed [rpm]}, 2 \times \text{Nominal slip [rpm]}\right\}$$

where

$$\text{Nominal slip [rpm]} = \text{Synchronous nominal speed [rpm]} - \text{Nominal speed [rpm]}$$

$$\text{Synchronous nominal speed [rpm]} = \frac{\text{Nominal frequency [Hz]} \times 60[\text{s}]}{\text{pole pair number}}$$

To make sure that the system is safe, parameters Allowed Deviation of Speed Sources and Speed Deviation Timer should be set to the smallest possible values with which the process can operate without the comparison fault appearing too often. Setting parameter Speed Deviation Timer to a greater value can give additional process availability but decrease the response time of the safety system in fault situations.

3.6.9 Estimated Speed and Gear Systems

Set the ratio between the speed measured by a sensor and estimated speed during parameterization of the option board. Estimated speed is calculated for the motor shaft. If the speed sensor is not on the motor shaft and thus measures a different speed, the ratio between the speeds must be set with parameters Gear Ratio Divider and Gear Ratio Multiplier. The safety functions operate in the external speed sensor speed level. In practice, the estimated speed calculated for the motor shaft is scaled to match to the external sensor speed level.

$$\text{Estimated speed (Actual) [rpm]} = \frac{\text{Estimated speed (Motor shaft) [rpm]}}{\text{Gear Ratio Multiplier} / \text{Gear Ratio Divider}}$$

The relation between the estimated speed and external speed sensor speed can be expressed by this formula:

$$\text{Estimated speed [rpm]} = \frac{\text{Gear Ratio Multiplier}}{\text{Gear Ratio Divider}} \times \text{external sensor speed [rpm]}$$

See the parameters related to estimated speed in [8.1.3 Speed Measurement Parameters](#).

3.6.10 Estimated Speed and External Accelerative Forces

If estimated speed is used in systems where the safe state is not the STO function alone, analyze the consequences on system level. As estimated speed is not calculated when the AC drive is not in RUN state, the safety system depends on the external speed sensor. During a standstill, only a single channel speed estimation is available. When external forces can cause acceleration and torque to the motor and make the motor rotate, a mechanical brake must keep the motor shaft stationary.

3.7 Storage of Parameters

It is possible to store the parameters of the Advanced safety option board as a backup in other locations. The different backup locations are handled in the control board of the AC drive. Use the control panel of the AC drive to control the parameter backup.

Table 15: Parameter Storing Locations

Location	Description	Checks and restrictions
OPTBL OPTBM OPTBN	The currently used parameter file is always saved on the option board.	In the start-up of the option board, the option board checks the parameter file to make sure that it is compatible. The option board always checks a new parameter file.
Control board of the AC drive	The currently used parameter file is uploaded to the control board during start-up and after each change in the parameter file. The parameter file is not stored permanently. To store the parameter file permanently in the control board as a backup, use the control panel.	The control board checks the CRC of the uploaded or stored parameter file to make sure that it is correct, but does not check the compatibility of the parameter values.
PC	The parameter files should be stored on the PC and in the version control or another system that is used to handle the configurations used on the field.	VACON [®] Safe creates unverified parameter files and stores verified parameter files "as is" without modifications to the safety critical and CRC protected area.

For more information on the PC tool VACON[®]Safe or the parameter file, see [5.2 The Parameter File](#).

The handling of the parameter file backup on the control board is not a safety critical feature, and it is the responsibility of the operator to use the correct parameters for the Advanced safety option board. A verified parameter file that is read from a backup to the option board will be accepted and taken into use. If the parameter file does not correspond to the actual configuration, for example, if it has a different encoder parameterized than what is supported by the used encoder interface board, the option board does not allow the STO function to be deactivated.

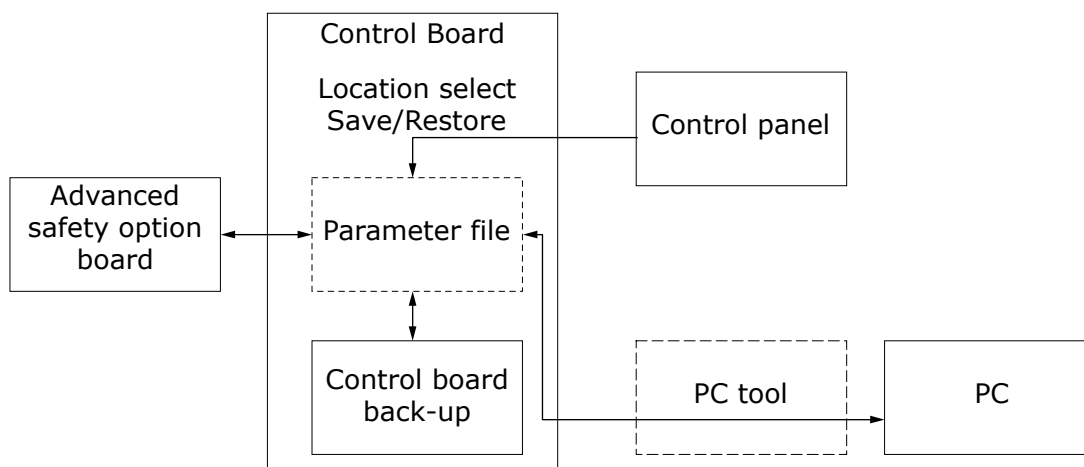

Illustration 17: The Backup Locations of the Parameter File and their Control

N O T I C E

Only compatible parameter files are taken into use on the option board. If the data in the backup location is faulty and sent to the option board, the option board detects the faultiness. The STO function stays active until a valid parameter file is provided.

3.7.1 Storing a Parameter File Backup

Use these instructions to store a parameter file backup from the Advanced Safety Option.

Procedure

1. Find parameter P7.4.1.1.3 Save Backup To under the menu group G7.4.1.1 Config Settings.
2. Select a backup location with parameter P7.4.1.1.3.
3. Make sure that the parameter file backup was stored successfully.
 - a. Make sure that the parameter file is also stored on the PC.
 - b. Do factory reset for the Advanced safety option board.
 - c. Do a parameter restore from the backup location.

3.7.2 Restoring a Parameter File from Backup

Use these instructions to restore a parameter file from a backup into Advanced Safety Option.

N O T I C E

When the parameter file is restored from backup, the passwords are reset to the default.

Procedure

1. Find parameter P7.4.1.1.4 Load Backup From under the menu group G7.4.1.1 Config Settings.
2. Select a backup location with parameter P7.4.1.1.4.
3. Make sure that the restored parameter file is accepted by the Advanced safety option board.
4. Make sure that the restored parameter file is the correct file.
 - a. Load and view the parameter file on VACON® Safe.
 - b. Check the parameter file CRC on the control panel.
 - c. Check the used safety functions on the control panel.
 - d. Check the parameter file creator and date on the control panel.
5. Set the passwords to the intended values if necessary.

3.8 Advanced Safety Options with the NXP Drive

3.8.1 Requirements

To use the Advanced safety option board with the VACON® NXP AC drive, obey these requirements.

Table 16: Required Drive Component Versions

Component	Version	Comment
The control board of VACON® NXP AC drive	Hardware: VB00761 B (141L8026) or newer Software: NXP00002V198 or newer	
The STO and ATEX option board (OPTAF)	Hardware: VB00328 E (141L7786) or newer	Check the safety levels of STO in the product manual.

When a safe fieldbus is used, see also [7.1.1 Introduction to PROFIsafe](#) for the fieldbus related requirements.

Table 17: The PC Tools that Can Be Used with the Option Board

PC tool	Version	Comment
NCDrive	2.0.29 or newer	Older versions than this can be used, but they do not show correctly the details of safety related faults.
VACON [®] Loader	1.1.12.0 or newer	The tool is used to update the option board firmware.
VACON [®] Safe	1.0.2.0 or newer	The tool is used to parameterize and monitor the option board. See 5.1 Functions of the VACON Safe Tool .

3.8.2 Compatibility with Drive Applications

The safety monitoring in the Advanced safety option board is independent of the drive application and of the methods used to control the AC drive to fulfill the monitored limits. The monitoring is always executed the same way. Violations of safety limits result in the set responses in the option board.

The option board can be used with any drive application. Older drive applications do not monitor or react to the safety system data. When a such drive application is used, the AC drive must be monitored and controlled by external systems for the AC drive to operate within the limits set by the safety functions.

For example, the drive application can ramp down and limit the speed to a safe value when the Safe Limited Speed (SLS) function is activated. Refer to the VACON[®]NX All-in-One Application Manual for more information.

NOTICE

It is possible to use any drive application with the Advanced safety option board, but some applications cannot operate correctly with the option board added to the system. In such cases, update the application.

The drive applications that are aware of the Advanced safety option board and able to use the related data can be used. A such drive application can keep the AC drive within the limits set by the safety functions.

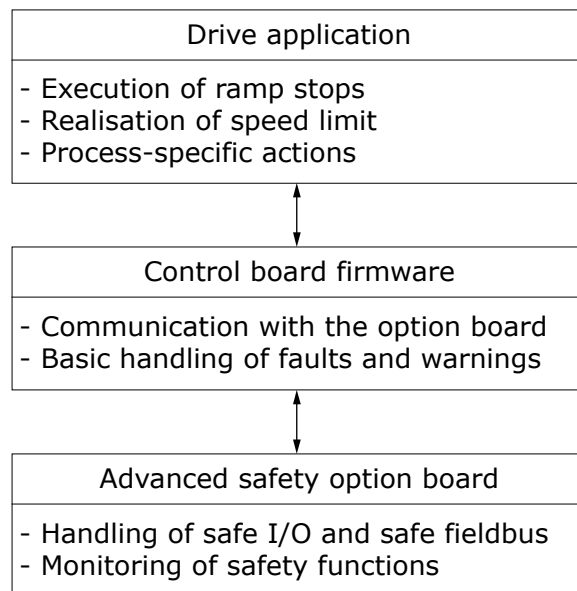

e30bi376.10

Illustration 18: Basic Tasks of the Option Board and the Control Board Firmware, and the Optional Tasks of the Drive Application

3.8.3 Option Board Menu on the Control Panel

When the Advanced safety option is used, use menu M7 Expander boards on the control panel of the drive to control the option board and to read status data. It is possible to reset the option board passwords, do a factory reset, and control of the parameter file backup. The status data includes the identification data for the parameter file, certain parameter values of the parameter file, and the run-time monitoring data.

The option board menu structure can be seen in [Illustration 19](#), and all the values are described in the tables below. The figure and tables are for installation in slot D. For other slots the indexes are different. For example, G7.4.1 Parameters is G7.3.1 Parameters in slot C.

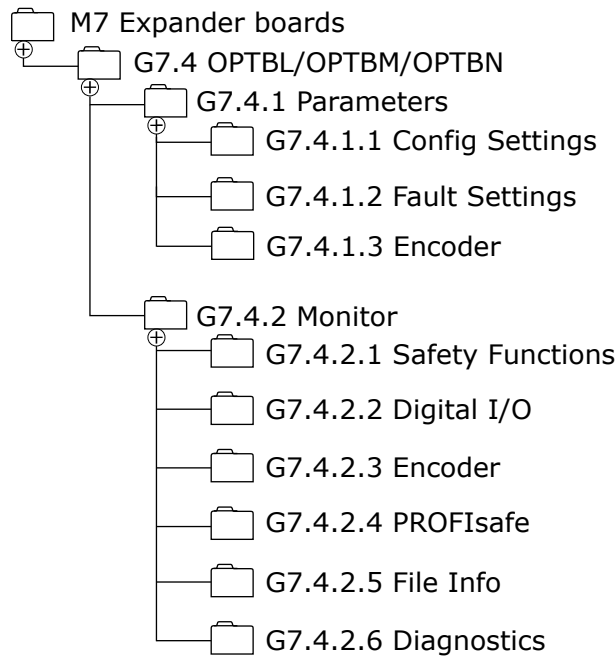

e30bi377.10

Illustration 19: The Menu Structure of the Menus Related to the Advanced Safety Option Board

Table 18: Config Settings Group (G7.4.1.1)

Index	Parameter	Min	Max	Unit	Default	ID	Description
P7.4.1.1.1	Password Reset	0	1	–	0	–	0 = No action 1 = Reset
P7.4.1.1.2	Factory Reset	0	1	–	0	–	0 = No action 1 = Reset
P7.4.1.1.3	Save Backup To	0	1	–	0	–	0 = No action 1 = Control unit 2 = Keypad (1)
P7.4.1.1.4	Load Backup From	0	1	–	0	–	0 = No action 1 = Control unit 2 = Keypad (1)

¹ Back-up to keypad requires a newer keypad unit with extended storage capability.

Table 19: Fault Settings (G7.4.1.2)

Index	Parameter	Min	Max	Unit	Default	ID	Description
P7.4.1.2.1	SafetySystem fit	0	2	–	0	–	Selects the control board firmware response for fault code 20. 0 = "Default", F20 activated as fault or warning depending on the case (application may decrease the reporting level, e.g. fault -> warning) 1 = "Warning", F20 activated as alarm

Index	Parameter	Min	Max	Unit	Default	ID	Description
							2 = "No Action", F20 not activated
P7.4.1.2.2	SafeF indication	0	2	-	0	-	Selects the control board firmware response to safety function status changes. 0 = "Default", F46/F47/F48 activated as alarm (application may decrease the reporting level, e.g. warning -> no action) 1 = "Violat only", F48 activated as alarm, F46/F47 not activated 2 = "No Action", F46/F47/F48 not activated

Table 20: Encoder (G7.4.1.3)

Index	Parameter	Min	Max	Unit	Default	ID	Description
P7.4.1.3.1 ⁽¹⁾	Reading Rate	0	4	-	1	-	Time used to calculate actual speed value. Note: Use value 1 in closed loop mode. 0 = No 1 = 1 ms 2 = 5 ms 3 = 10 ms 4 = 50 ms

¹ The menu group is accessible only when the Advanced safety option board is installed in slot C.

Table 21: Safety Functions Group (G7.4.2.1)

Index	Parameter	Min	Max	Unit	Default	ID	Description
V7.4.2.1.1	STO	-	-	-	-	-	Shows the status of the safety function. Not in use = The function is not taken into use in the parameter file. Inactive = The safety function is not requested. Requested = The safety function is requested. Active = The safety function is active. (The signal xxx Active is "1".) Reached = The safety function is reached. (The signal xxx Reached is "1".)
V7.4.2.1.2	SS1	-	-	-	-	-	
V7.4.2.1.3	SS2	-	-	-	-	-	
V7.4.2.1.4	SQS	-	-	-	-	-	
V7.4.2.1.5	SSR	-	-	-	-	-	
V7.4.2.1.6	SLS 1	-	-	-	-	-	
V7.4.2.1.7	SLS 2	-	-	-	-	-	
V7.4.2.1.8	SLS 3	-	-	-	-	-	
V7.4.2.1.11	SSM	-	-	-	-	-	
V7.4.2.1.12	SMS	-	-	-	-	-	
V7.4.2.1.14	SOS	-	-	-	-	-	
V7.4.2.1.15	SBC	-	-	-	-	-	

Table 22: Digital I/O Group (G7.4.2.2)

Index	Parameter	Min	Max	Unit	De- fault	ID	Description
V7.4.2.2.1	DI1 DI2 DI3 DI4	-	-	-	-	-	Shows the logical value of the option board digital input. Updated only for inputs that have safety functions assigned. 0 = The input is inactive 1 = The input is active - = The input is not used
V7.4.2.2.2	DO1 DO2	-	-	-	-	-	Shows the logical value of the option board digital output. 0 = The output is inactive 1 = The output is active - = The output is not used

Table 23: Encoder Group (G7.4.2.3)

Index	Parameter	Min	Max	Unit	De- fault	ID	Description
V7.4.2.3.1	Encoder Type	-	-	-	-	-	Shows the encoder type specified in the parameter file. Values: <ul style="list-style-type: none"> • None • Increm. TTL • Increm. HTL • SinCos
V7.4.2.3.2	Estimated Speed	-	-	-	-	-	Shows whether estimated speed is used in the parameter file. Values: <ul style="list-style-type: none"> • Not in use • In use
V7.4.2.3.3	Proximity Sensor	-	-	-	-	-	Shows the number of used proximity sensors in use. Values: <ul style="list-style-type: none"> • None • 1 • 2
V7.4.2.3.4	Encoder Speed	-	-	rpm	-	-	Shows the average speed measured by the option board (encoder and proximity sensors)
V7.4.2.3.5	Encoder Freq	-	-	Hz	-	-	Shows the speed of the motor based on the encoder data.

Table 24: PROFIsafe Group (G7.4.2.4)

Index	Parameter	Min	Max	Unit	Default	ID	Description
V7.4.2.4.1	Safety Telegram	–	–	–	–	–	Shows the number of the used telegram. Values: <ul style="list-style-type: none"> • ST 30 • ST 31 • ST 58000
V7.4.2.4.2	F-Par SRC Addr	–	–	–	–	–	Shows the value of F Source Address
V7.4.2.4.3	F-Par DEST Addr	–	–	–	–	–	Shows the value of F Destination Address
V7.4.2.4.4	F-Par WD Time	–	–	–	–	–	Shows the value of F WD Time

Table 25: File Info Group (G7.4.2.5)

Index	Parameter	Min	Max	Unit	Default	ID	Description
V7.4.2.5.1	File Name	–	–	–	–	–	Shows the first 12 characters of parameter File name
V7.4.2.5.2	File Creator	–	–	–	–	–	Shows the first 12 characters of parameter File creator
V7.4.2.5.3	Company Name	–	–	–	–	–	Shows the first 12 characters of parameter Company (Parameter file)
V7.4.2.5.4	CRC	–	–	–	–	–	Shows the CRC of the used parameter file in hex format
V7.4.2.5.5	CRC integer	–	–	–	–	–	Shows the CRC of the used parameter file in decimal integer format

Table 26: Diagnostics Group (G7.4.2.6)

Index	Parameter	Min	Max	Unit	Default	ID	Description
V7.4.2.6.1	Last Error Code	–	–	–	–	–	Shows the number of the last fault of the Advanced safety option board in hex format.
V7.4.2.6.2	SW Version	–	–	–	–	–	Shows the software version of the Advanced safety option board.
V7.4.2.6.3	HW Version	–	–	–	–	–	Shows the hardware version of the Advanced safety option board.
V7.4.2.6.4	FPGA Version	–	–	–	–	–	Shows the FPGA version of the encoder interface board on the Advanced safety option board.

3.8.4 Fault Types

The Advanced safety option board has different fault types: critical fault, resettable fault, violation, and warning. The fault types of the Advanced safety option board are not the same as the fault types of the AC drive. For more details on faults, see [12.1 Presentation of Faults on the Control Board](#).

Table 27: Fault types of the Advanced safety option board

Fault type of the option board	Possible cause	Correction	Fault type of the AC drive	Response of the option board
Critical Fault	Internal broken hardware, incorrect configuration, temporary malfunction detected by the diagnostics.	Attempt to fix the issue. Reboot of the AC drive.	Fault	The STO function becomes active, all outputs are inactive.
Resettable Fault	External broken hardware, incorrect configuration, temporary malfunction detected by the diagnostics.	Attempt to fix the issue. Cleared with the reset signal. See 6.1.6 Reset of a Safety Function .	Fault	The STO+SBC function becomes active, see 6.2.2.3 The STO Function Used with the SBC Function .
Violation	Violation of a monitoring limit in an active safety function.	Cleared with the reset signal. See chapters 6.1.4 Violation of a Safety Function and 6.1.6 Reset of a Safety Function .	Warning	Safe monitoring functions: the SQS function. Safe stopping functions: the STO+SBC function.
Warning	An event that does not affect the operation, but is shown for information.	Does not require clearing. / Cleared with the reset signal.	Warning	No response.

Failures that are detected by the internal diagnostics of the option board trigger a fault. The faults can be resettable or critical. Resettable faults are informed to the control board of the AC drive and reported on the fault log of the AC drive. They can be cleared by a reset signal. See [6.1.6 Reset of a Safety Function](#).

Critical faults of the option board cause the option board to deactivate its outputs and communication to other systems. This means that both the channels of the two-channel outputs are in the deactivated state. The safe fieldbus communication is also stopped. To other systems, the situation looks as if the option board is not turned on or the cabling is faulty. Take this into account when designing and implementing other systems.

If the fault that causes the critical fault does not have an effect on the communication between the option board and the control board of the AC drive, this communication stays active. The fault data can be read from the fault log of the AC drive. If the fault is related to the communication or otherwise prevents the option board from communicating with the control board, the communication stops. In this case, the fault data cannot be read from the fault log.

N O T I C E

If the option board starts after a reboot of the AC drive, it may be possible to read the fault data in the activity log of the Advanced safety option board. See [5.6.2 Activity Log](#).

4 Installation

4.1 Installation Safety

Read these warnings before starting the installation of the option board.

⚠ WARNING ⚠

SHOCK HAZARD FROM CONTROL TERMINALS

The control terminals can have a dangerous voltage also when the drive is disconnected from mains. A contact with this voltage can lead to injury.

- Make sure that there is no voltage in the control terminals before touching the control terminals.

⚠ CAUTION ⚠

DAMAGE TO OPTION BOARDS

Do not install, remove, or replace option boards on the drive when the power is on. Doing this can cause damage to the boards.

- Switch off the AC drive before installing, removing, or replacing option boards on the drive.

NOTICE

Measure or do a check of the encoder supply voltage of the encoder interface board before connecting a new encoder. It is possible that the encoder supply voltage was set to a higher voltage than what is supported by the new encoder. An incorrect encoder supply voltage can damage the equipment.

4.2 Installing the Option Board

This topic gives instructions for installing the option board in VACON[®]NXP, FR4–FR9.

Procedure

1. In FR5–FR9, open the cover of the AC drive.
2. In FR4, remove the cable cover.

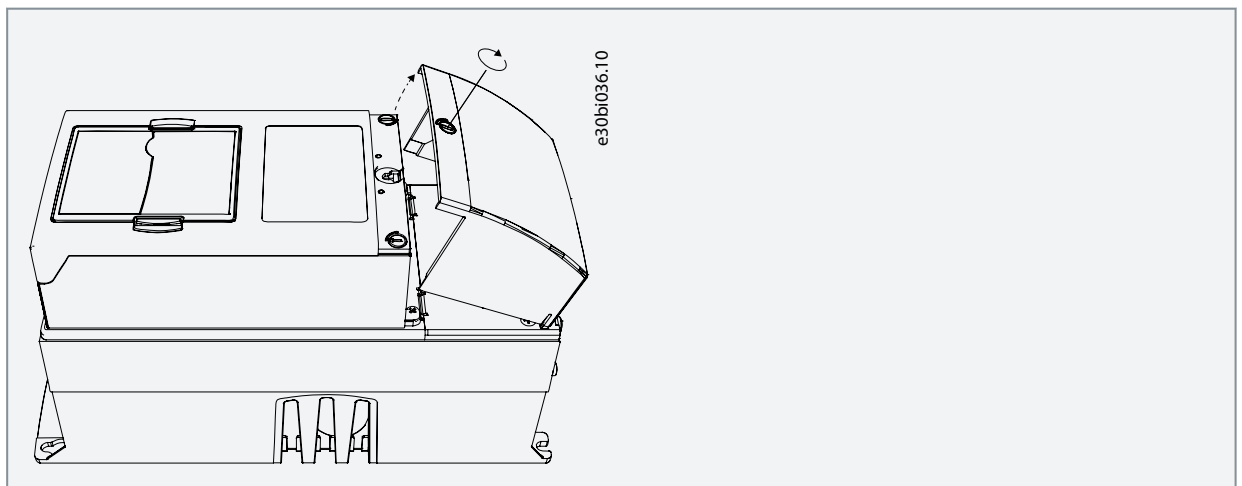

3. Open the cover of the control unit.

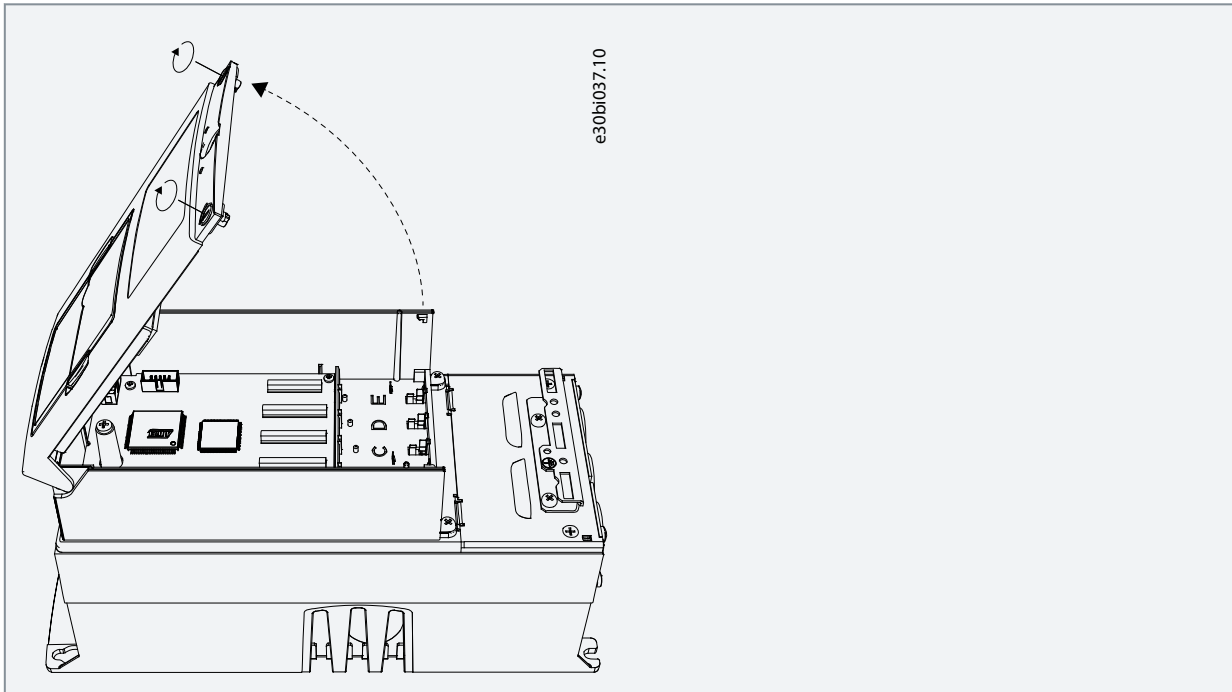

4. Install the option board into the slot C, D, or E on the control board of the AC drive. Make sure that the grounding plate fits tightly in the clamp.

The board revision can affect the applicable installation slot.

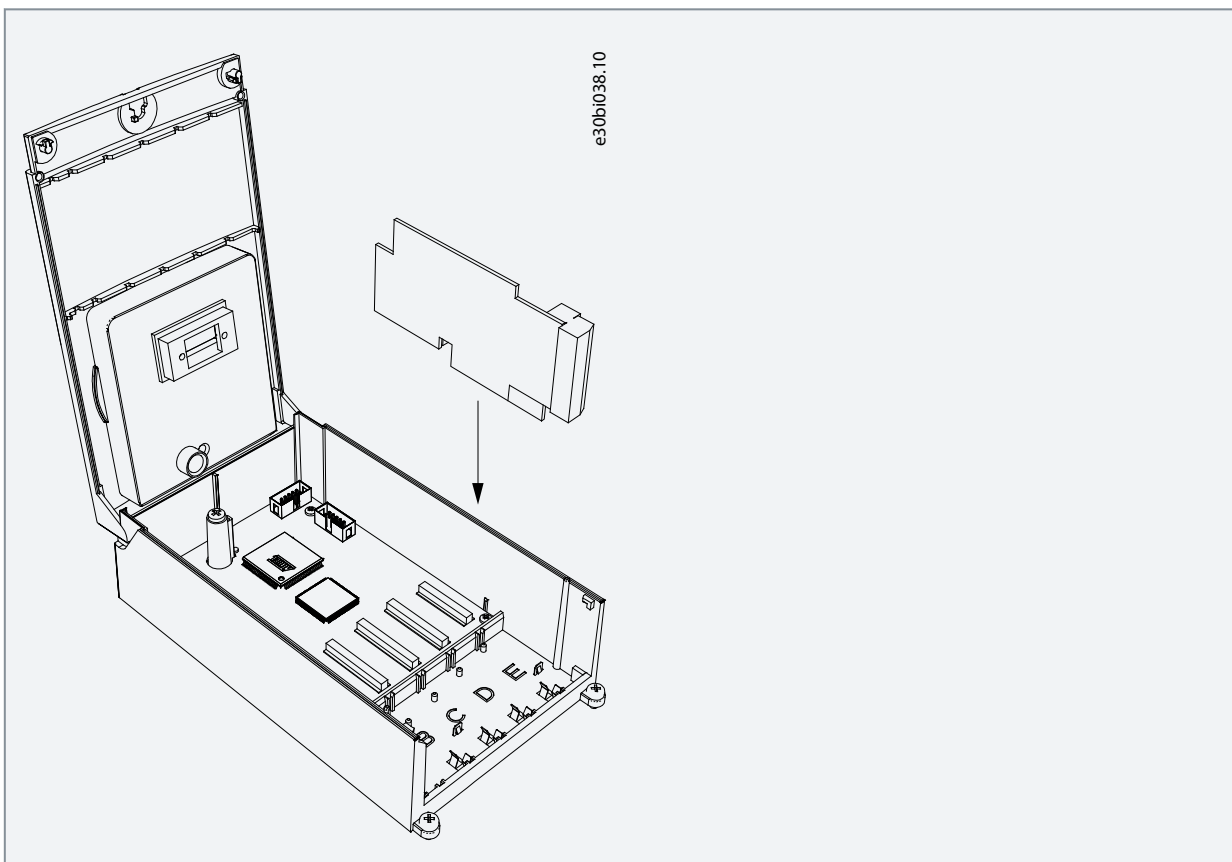

5. In IP21, cut free the opening on the cover of the AC drive for the fieldbus cable.
6. Install the cables.
7. Close the cover of the control unit and attach the cable cover.

5 VACON Safe Tool

5.1 Functions of the VACON Safe Tool

Use the VACON[®]Safe tool to parameterize the Advanced safety option board.

The functions of the VACON[®]Safe tool

- Parameterization of the option board
- Validation of the parameter file
- Monitoring of the state of the option board and the safety functions
- Setting the passwords for the option board

N O T I C E

VACON[®]Safe tool cannot be used for the general control and diagnostic of the AC drive. For those purposes, use NCDrive. The option board firmware is updated with VACON[®]Loader.

5.2 The Parameter File

The configuration of the Advanced safety option board and the selected safety functions and their parameters are stored in a parameter file. The parameter files are created, viewed, and transferred between a PC and the option board with the VACON[®]Safe tool.

A newly created parameter file on the PC is in state **unverified**. This means that the Advanced safety option board has not yet verified that the file is valid and can be taken into use. Once the option board has done the verification, the parameter file becomes **verified**. The verification is done during the parameterization process.

If the verified parameter file is not modified, it can be saved to other Advanced safety option boards. The other option boards check the parameter file to make sure that the content is not corrupted and that it matches the option board configuration, for example, the encoder type.

The verification of a parameter file means that it can be taken into use, but the option board cannot determine if the parameter values are correct for the process where the option board is used. After the verified parameter file is saved to the option board, test the whole safety system to make sure that all safety subsystems operate correctly together. Test also that the safety functions of the Advanced safety option board are correctly set for the process. After the testing, the parameter file can be updated to indicate that it has been tested with the rest of the system.

After testing, the parameter file is **validated**. Validated parameter files can be saved to other Advanced safety option boards, like verified parameter files, but the validation is cleared in the process. The report from commissioning should be included in the documentation and in the process of certifying the whole system.

5.3 User Levels and Password Management

To protect the parameters of the option board from accidental modifications, the option board has a two-level password system. The admin and service level passwords have different rights for modifying the parameters of the option board.

A password is required in actions that write data on the option board. Reading actions are not password-protected. The PC tool asks for the password when you try to start an action that requires a password. The default passwords are listed in the table below.

Table 28: Default Passwords

User level	Default password
Admin	admin
Service	service

Actions that are available with the service level password

- Validation of the parameter file
- Saving the verified parameter file to the option board

Actions that are available with the admin level password

- Validation of the parameter file
- Saving the verified parameter file to the option board
- Saving a new, unverified parameter file to the option board
- Changing the admin and service level passwords

Actions that are available without a password

- Reading the verified parameter file from the option board
- Online monitoring of the option board

N O T I C E

If the passwords are forgotten, they can be reset from the control panel menu of the AC drive. This operation is not password-protected. The controlling of password reset must be done with other means.

5.4 Setting the Parameters

The parameterization process of the Advanced safety option board has 4 steps.

Procedure

1. To select the desired safety functions and features, go to "Select functions" in the PC tool.

A short description is visible for every available option. For information on the safety functions, see chapter Safety Functions.

2. Go to "Adjust parameters" in the PC tool.

All selected safety functions and features must be parameterized. See chapter Parameter List for information on the parameters.

When all safety functions and features have been parameterized, it is possible to save the parameter file to the option board. The option board checks the compatibility of the parameter file. Only valid parameter files are accepted. VACON[®] Safe also limits the parameterization, so that invalid combinations are not sent to the option board.

N O T I C E

It is possible to save the current parameterization as a draft on the PC.

N O T I C E

Saving a new parameter file to the option board requires the admin level password.

3. Verify the transfer of parameters to the option board. Go to "Verify and Approve".

The verifying view offers automated checks.

Accepting the parameters takes them into use in the option board. The parameter file is verified but not validated, that is, it is not tested with the rest of the system.

➔ The parameter file is marked as verified by the option board. A verified parameter file can be loaded from the option board and stored on the PC.

4. Validate the parameter file by going to "Validate".

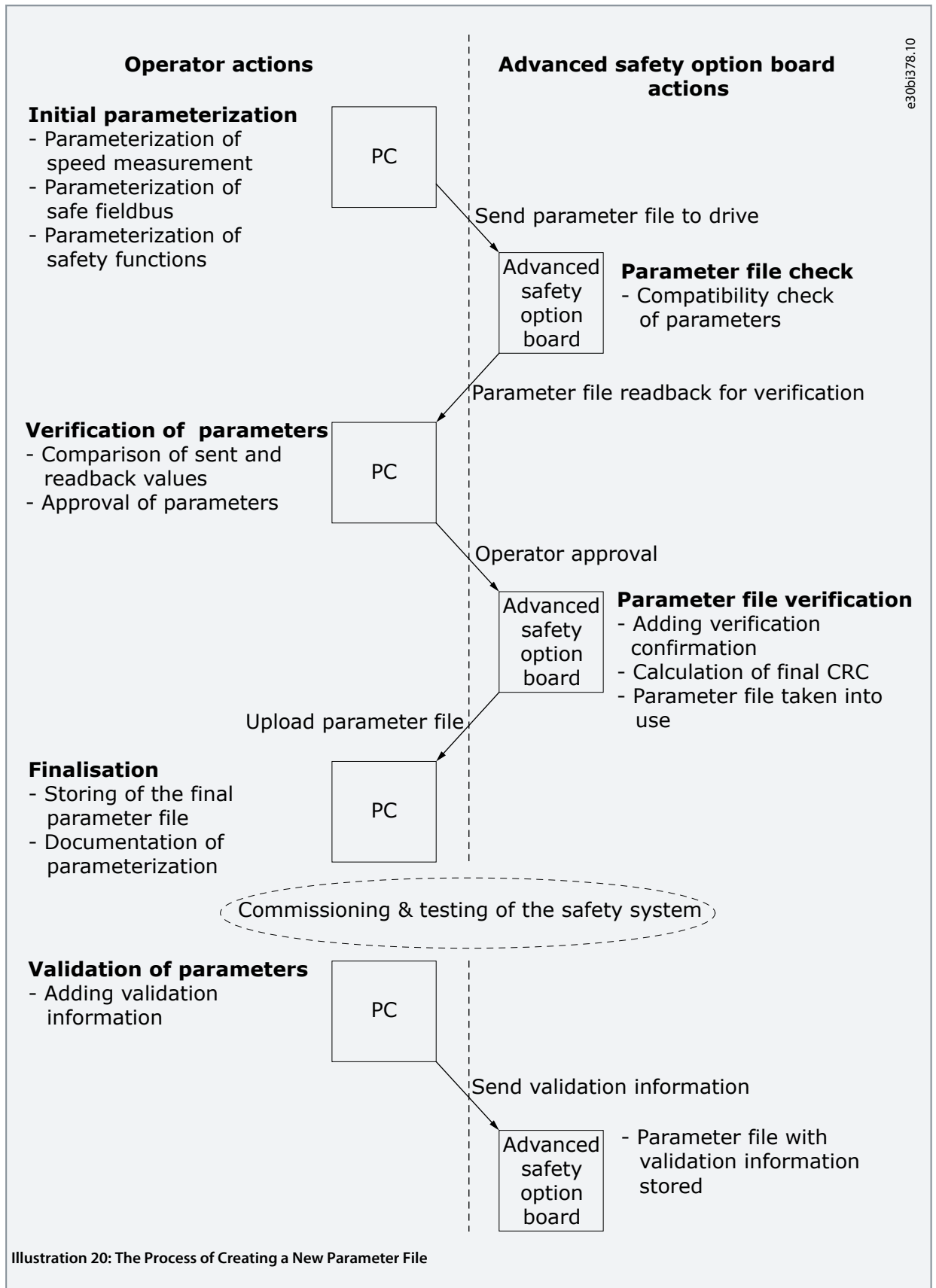

Illustration 20: The Process of Creating a New Parameter File

5.5 Saving a Verified Parameter File to the Option Board

A verified parameter file can be saved to the option board without executing the whole parameterization process. Saving a verified parameter file can be done with the service level password. Modifications to a verified parameter file invalidate the verification and the verification must be done again.

Procedure

1. Open the verified parameter file. Make sure that also the PC tool confirms that it is verified.
2. Check the parameters in the opened file. For example:
 - a. Make sure that the I/O assignments match the wiring.
 - b. Make sure that the correct safety functions are parameterized.
 - c. Read the parameter file comment.
3. Press "Save" to begin the saving process.
4. Select an AC drive and connect to it.
5. Save the parameter file and start testing the system.

5.6 Online Monitoring

5.6.1 Viewing the State of the Option Board

In the online monitoring mode, VACON[®]Safe reads the states and values of various signals of the Advanced safety option board from the AC drive. These signals can be used to monitor the status and execution of the safety features of the AC drive.

The data available for monitoring:

- States of the safety functions
- States of the digital I/O
- Speed values (estimated speed, the measured speed value of the external speed sensor)
- Safe fieldbus status

NOTICE

Online monitoring values are periodically read from the AC drive and the actual values can change between the readings.

5.6.2 Activity Log

The Advanced safety option board logs the events that occur during its operation. This log can be read from the option board and viewed on the PC tool. Some of the data included in the log is also available when the state of the option board is viewed. The activity log can be used when it is necessary to analyze the behavior of the option board during a time when the PC tool was not connected to the option board. The log can be saved to the PC for further use.

The activity log contains

- A timestamp that is synchronized to the AC drive operating time
- Request signals for safety functions
- Active and Reached signals for safety functions
- Acknowledgment and Reset signals and their source
- Information on the faults that occurred in the option board

The activity log logs the states of the signals when a change occurs in them. The length of the activity log is limited. Depending on the used safety functions and the frequency of changes in the safety functions, the log may show only a short time. When there is a situation that requires analysis, read the log as soon as possible to prevent new events from overwriting the critical parts.

The log is not lost when you do power-down to the AC drive.

6 Safety Functions

6.1 General Information

6.1.1 The Different Safety Functions

The safety functions of the Advanced safety option board fulfill the corresponding requirements of the standard EN IEC 61800-5-2. The standard EN IEC 61800-5-2 does not define the SQS safety function, but the function can be parameterized to behave like STO(+SBC), SS1 or SS2. These functions fulfill the requirements of the standard.

The safety functions are divided into two categories: the safe stopping functions and the safe monitoring functions. The safe stopping functions start and monitor the stopping of the motor, the safe monitoring functions monitor the speed, the position, or the acceleration of the motor.

The safe stopping functions

- the STO function
- the SBC function
- the SS1 function
- the SS2 function
- the SOS function
- the SQS function

The safe monitoring functions

- the SLS function
- the SMS function
- the SSR function
- the SSM function

The SQS function can be used in STO, SS1 or SS2 modes. In this manual, these modes are referred to as SQS-STO, SQS-SS1, and SQS-SS2.

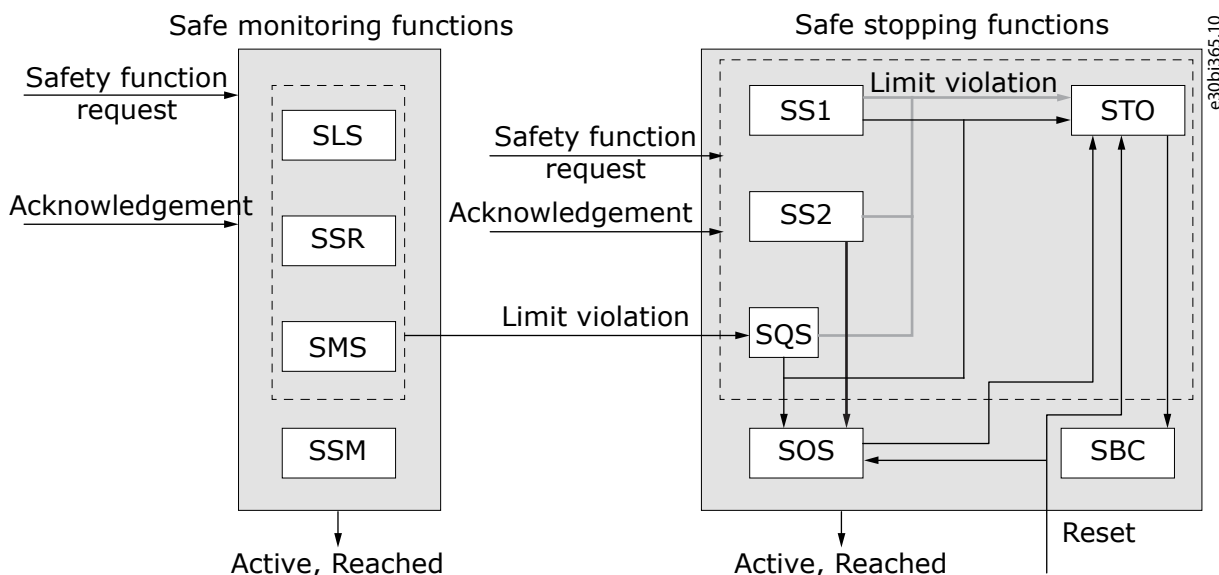

Illustration 21: The Simplified Relations Between the Safety Functions

6.1.2 Safety Function States

The safety functions can be in three different states: inactive, active, and reached. The safety functions that are not requested or have been acknowledged after their execution are inactive. Inactive safety functions are not executed and they do not do any monitoring. The states active and reached are shown with signals.

An inactive safety function becomes active when it receives a request. An active safe stopping function becomes reached when the function is completed. An active safe monitoring function becomes reached when the monitored values are within the monitoring limits.

Active and reached functions can have their monitoring limits violated.

When the STO function is active in the option board, for example because of a violation or a fault, all active safety functions stop the monitoring of their limits. The functions stay active until they are acknowledged. The SSM function is an exception. It continues to monitor even during standstill of the motor and violations of other safety functions.

6.1.3 Activation of a Safety Function

Most safety functions can be activated with an external request from a safe digital input or a safe fieldbus. Both methods can be used at the same time. When the two methods are used, a request from one source is sufficient to activate the safety function. When a safety function becomes active, it gives an Active signal. Many functions can be active at the same time, but this does not apply to all functions. Any combination of safe monitoring functions can be active at the same time, but for the safe stopping functions there are limitations because of their set priorities.

These safety functions can be activated with an external request from a digital input or a safe fieldbus: STO(+SBC), SS1, SS2, SQS, SSR, SLS, SSM, and SMS.

The safety functions that cannot be activated with an external request are SBC and SOS. They are always activated by other safety functions. The safety function STO activates SBC. The safety functions SS2 and SQS-SS2 activate SOS.

Some safety functions can also become active without an external request. The SQS function can become active as a violation response, the SSM function when always active, and the STO function as a violation response of safe stopping functions.

In some special conditions, a function cannot become active even if there is a request. These conditions include a request for a lower priority function, an active violation or fault in the Advanced safety option board, and the active STO safety function. When the Advanced safety option board is in the STO state, for example, because of a STO request, it is not necessary to activate safety functions.

N O T I C E

Most safety functions do not become active or start operating if the drive is in the STO state. If there is a request, they become active when the drive leaves the STO state.

In this manual, the external request signal has the format "[Safety Function Name] Request", for example "SMS Request".

6.1.4 Violation of a Safety Function

It is possible that violations occur in the monitoring. Causes for violations are, for example, the speed exceeding the monitored speed limit, the speed not following the monitored ramp, or an operation exceeding the set time limit.

There are two different violation responses:

- the STO (+SBC) function
- the SQS function

N O T I C E

NO AUTOMATIC RAMP WITH SQS FUNCTION

When the SQS safety function is used, the Advanced safety option board does not execute any ramps on its own. Make sure that the system reacts to violation situations in an acceptable way.

- Execute a ramp stop by a drive application with safety support. See [13.3 SS1 Used with STO\(+SBC\)](#).
- Execute a ramp stop by a drive application without safety support by triggering a stop command externally.
- Execute a ramp stop by a process control system. See [13.4 SS1 Without a Direct Support of the Drive Application](#) and [13.6 SLS without a Direct Support of the Drive Application](#).

For safe stopping functions, the response to a violation is the STO (+SBC) function. For safe monitoring functions excluding SSM, the response to a violation is the SQS function.

With the SSM function, there is no response to a violation. Instead, external systems are notified of the violation by a digital output or a fieldbus.

To make a safety function recover from a violation, use a reset signal. See [6.1.6 Reset of a Safety Function](#).

6.1.5 Acknowledgment of a Safety Function

6.1.5.1 Acknowledgment of a Safety Function

The acknowledgment signal is used to deactivate a safety function that has been set to require a manual acknowledgment after the safety function request has ended. The acknowledgment mode can be set as automatic or manual.

In the automatic mode, the acknowledgment is tied to the deactivation of the safety function request. In the manual mode, a separate acknowledgment signal from a digital input, the drive control board, or a fieldbus is necessary.

The selection between automatic and manual acknowledgment is made with a parameter and separately for each function. It is possible to use functions with different acknowledgment settings at the same time.

A function can be acknowledged when these conditions apply:

- There is no request signal.

When executed as a violation response, the SQS safety function may not be acknowledged separately. It is acknowledged as a part of the safety function reset. See [6.1.6 Reset of a Safety Function](#).

If a function is set to have automatic acknowledgment, the function is deactivated when its request is deactivated.

NOTICE

A higher priority safe stopping function can interrupt a lower priority safe stopping function before it is reached.

The manual acknowledgment signal has three allowed sources:

- A safe digital input
- A safe fieldbus
- A not safe control board of the AC drive

The sources of the acknowledgment signal are equal. A manual acknowledgment signal from any of them is permitted to stop a safety function.

The acknowledgment signal from the control board of the drive is sent when a fault reset command (drive input, fieldbus, drive application, or drive control panel) is sent to the drive. You can disable the acknowledgment signal from the control board during parameterization.

NOTICE

When a safety function is requested by both a digital input and a fieldbus, both of them must deactivate the request before the function can be acknowledged. When the last request is deactivated, the automatic acknowledgment signal becomes active, and the manual acknowledgment signal becomes acceptable.

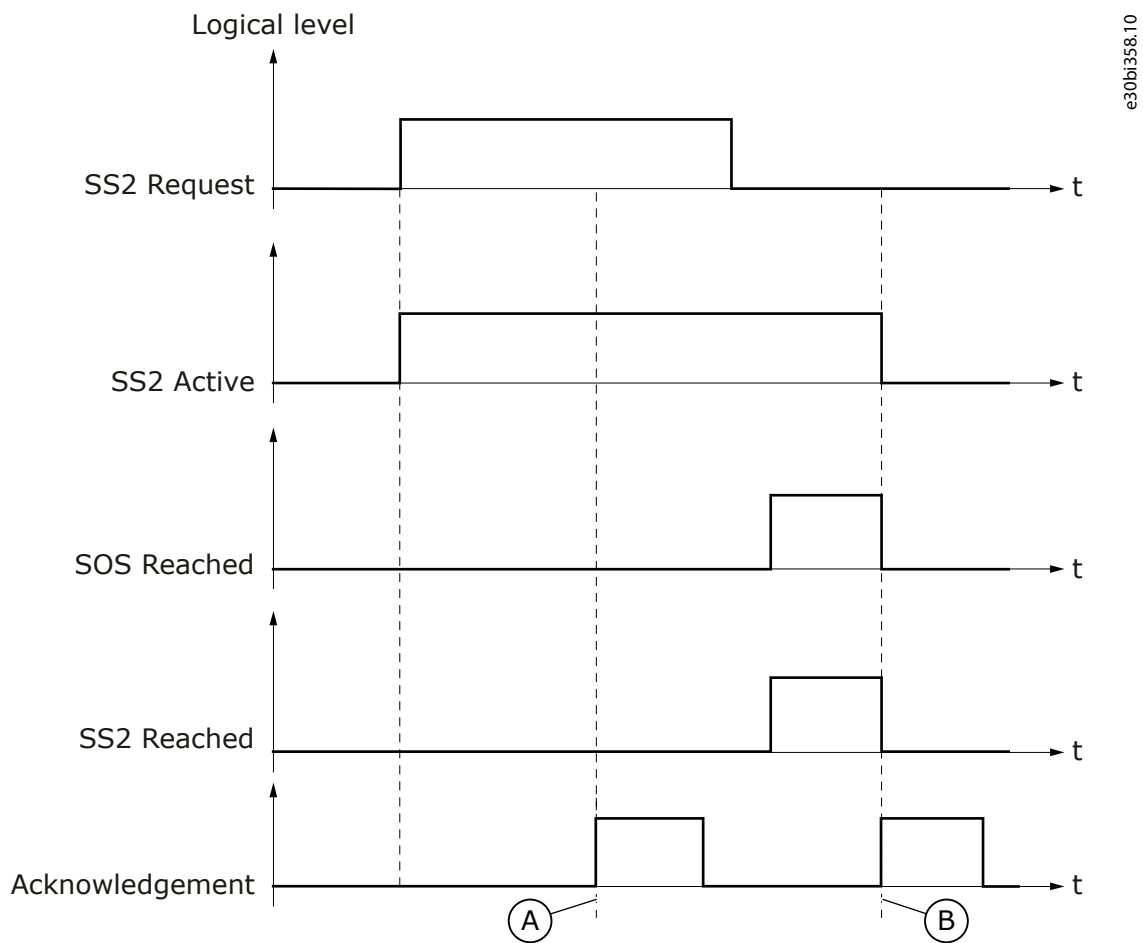

e30bi358.10

Illustration 22: The Deactivation of the SS2 Request Before the Function is Reached. Acknowledgment: Manual.

- A The manual acknowledgment is rejected because the safe stopping function is requested
- B After the safety functions are not requested, the manual acknowledgment is accepted.

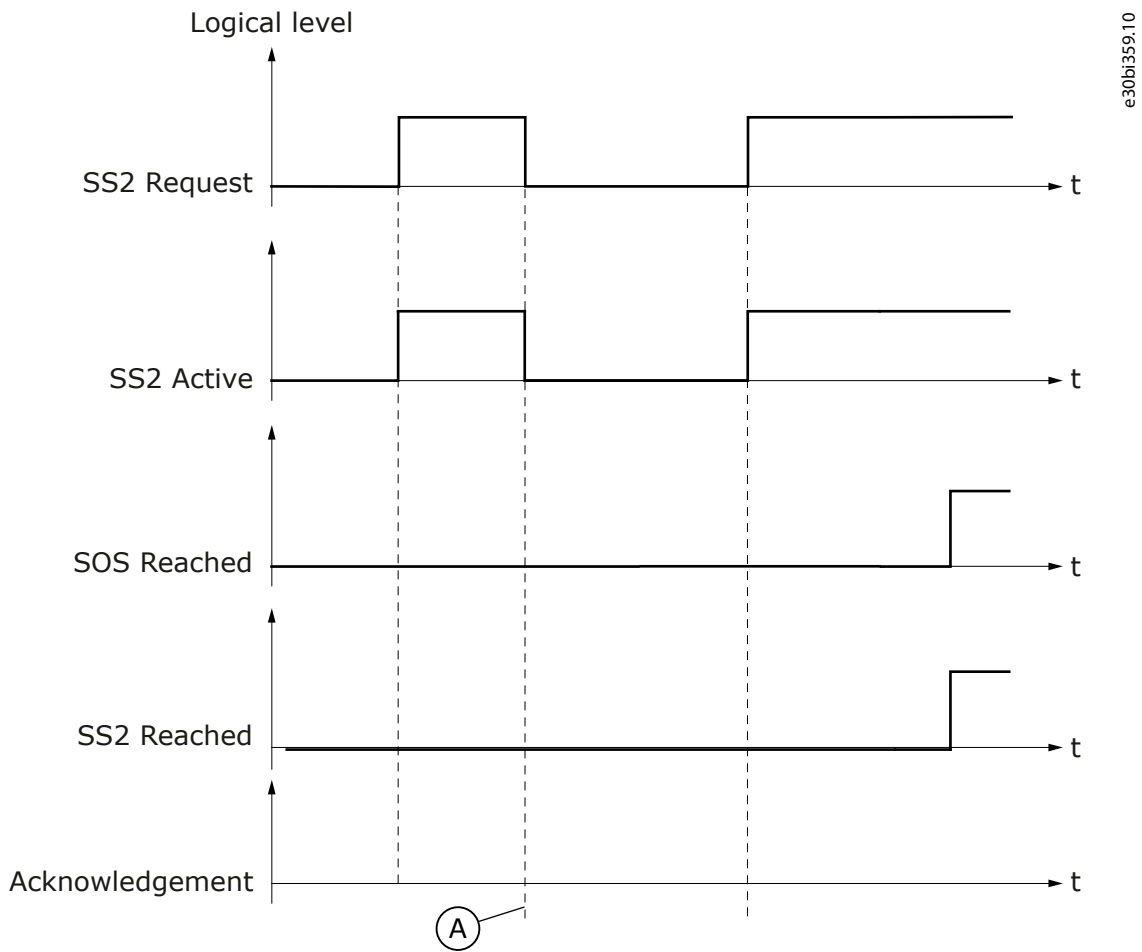
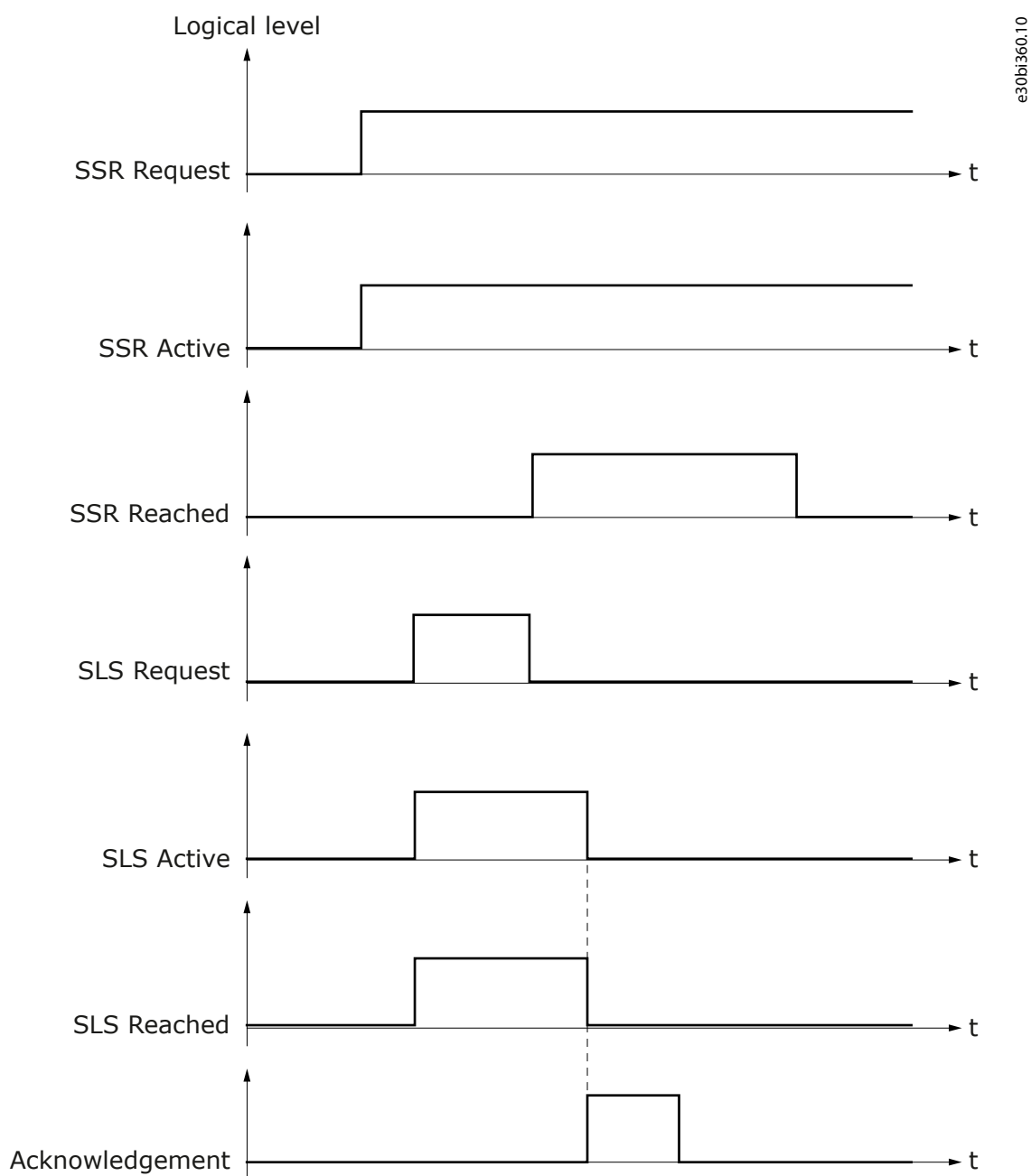

Illustration 23: The Deactivation of the SS2 Request Before the Function is Reached. Acknowledgment: Automatic.

A The automatic acknowledgment occurs when the SS2 request ends.

When there are safety functions that can be acknowledged by manual acknowledgment and safety functions that cannot (if, for example, they are requested), a manual acknowledgment signal deactivates the functions that can be acknowledged. Functions that could not be acknowledged continue their execution normally.



e30bi360.10

Illustration 24: Acknowledging a safety function separately. The SLS function is acknowledged. The SSR function is not acknowledged because it stays requested. SLS: manual acknowledgment, SSR: manual acknowledgment.

NOTICE

After safe stopping functions are acknowledged and the STO function is deactivated, the drive can start if it has an active run request.

The acknowledgment signal can also be used to control accidental starts of the drive. If the deactivation of the request of a safe stopping function should not be able to allow the drive to start, use the manual acknowledgment. The drive can then start only after a separate acknowledgment signal.

If a safe stopping function is used as an emergency stop according to the standard IEC-60204-1, the acknowledgment signal can be used as the reset signal required by the standard. The reset signal of the Advanced safety option board does not correspond to the emergency stop reset signal described in the standard.

In digital inputs, the acknowledgment signal is edge sensitive. The acknowledgment is done with inactive -> active transition (logical level). In safe fieldbuses, the acknowledgment signal is also edge sensitive, and it is done with a 0 -> 1 transition of the related telegram bit.

NOTICE

Acknowledgment and Reset can be assigned to the same digital input of the Advanced safety option board. Consider the behavior of the safety functions and the safety system carefully, if you decide to do that.

6.1.5.2 Start-up Acknowledgment

In addition to acknowledging safety functions, the acknowledgment signal can also be used to permit the Advanced safety option board to release STO(+SBC) after start-up. This acknowledgment signal can be automatic or manual.

If automatic acknowledgment is used, STO(+SBC) is released after the Advanced safety option board has done the start-up and established communication to the drive control board and over safe fieldbus (when used). If manual start-up acknowledgment is used, the STO(+SBC) is kept active until the acknowledgment signal is received.

6.1.6 Reset of a Safety Function

Violations of safety functions or faults of the Advanced safety option board cause the STO(+SBC) function to be activated. Use a reset signal to deactivate the STO(+SBC) function, reset faults and return the system to normal operation. For the Advanced safety option board, the reset signal is always an explicit signal from another system.

NOTICE

If the SQS-SS2 function is used, a violation of a safe monitoring function can activate the SOS function. You can reset the SOS function in the same way as the STO function.

The reset signal has three allowed sources:

- A safe digital input
- A safe fieldbus
- A not safe control board of the AC drive

The sources of the reset signal are equal. A reset signal from any of them is permitted to reset violations of safety functions and faults in the Advanced safety option board.

The reset signal from the control board of the drive is sent when a fault reset command (drive input, fieldbus, drive application, or drive control panel) is sent to the drive. If a safe reset signal is required, disable the reset signal from the control board of the AC drive in parameterization.

Different conditions apply for resetting the violations of safety functions and the faults of the Advanced safety option board.

To reset violations of safety functions or faults of the Advanced safety option board, these conditions apply:

- STO(+SBC) or SOS is active (SOS in case of SQS-SS2)
- The speed is below the monitoring limit of all requested safety functions

In digital inputs, the reset signal is edge sensitive. The reset is done with inactive -> active transition (logical level). A reset over a safe fieldbus depends on the selected fieldbus. See [7.1.1 Introduction to PROFsafe](#) for information on the differences of the fieldbuses.

NOTICE

After a violation or a fault, the reset signal behaves as an implicit acknowledgment signal for safety functions for which acknowledgment conditions apply when a reset signal is sent.

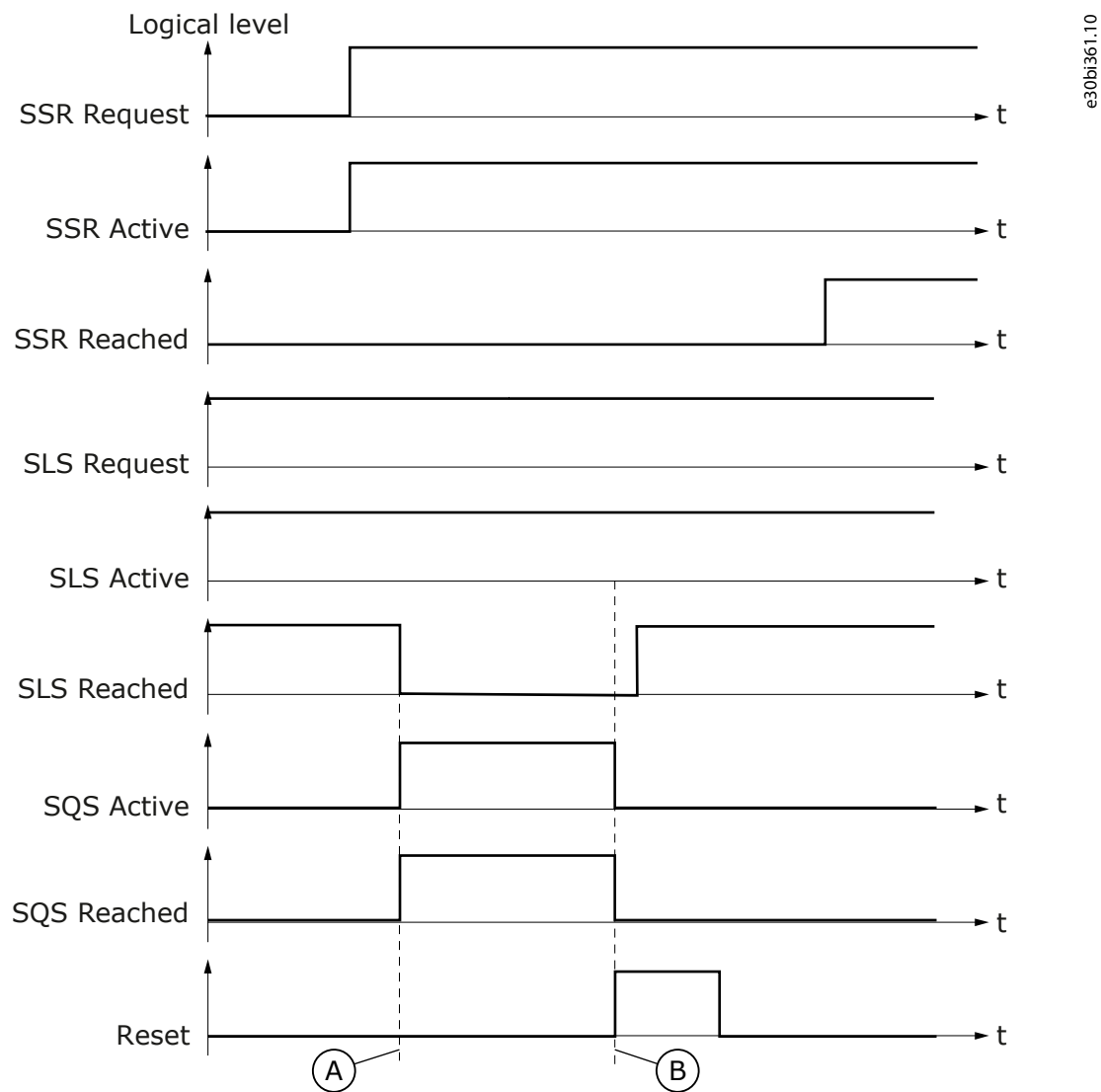

Illustration 25: Resetting a Safety Function Separately. SLS: Manual Acknowledgment.

- A A violation in the SLS function.
- B A reset signal resets the violation. The operation of the SSR and SLS functions continues.

NOTICE

Acknowledgment and Reset can be assigned to the same digital input of the Advanced safety option board. Consider the behavior of the safety functions and the safety system carefully, if you decide to do that.

NOTICE

Some faults of the Advanced safety option board can only be reset with a reboot of the drive. See chapter Fault Tracing for more information.

There can be a delay between the reset signal and the removal of faults and warnings from the AC drive.

6.1.7 Ramps

The safety functions SS1, SS2, SQS, SSR, and SLS can monitor the ramping of the motor speed. The ramps are optional, and all safety functions that provide ramp monitoring can be parameterized to not monitor them.

The monitored ramps are defined with two shared ramp definitions that the other safety functions than the SQS function can use to calculate the actual ramps. The SQS function has its own ramp values. The ramp definition has a maximum and a minimum time that is permitted for the ramping.

NOTICE

When a safety function uses a ramp, the related ramp must be defined. It is not necessary to parameterize both minimum and maximum ramps if they are not necessary for the application.

Deceleration ramps are defined by a nominal speed value and two time values that represent the maximum and minimum time that the ramping from the nominal speed is permitted to take. The actual monitored ramps are calculated when ramp monitoring starts. The ramps are defined as slopes between the request moment and the parameterized times (SS1 used as an example).

$$SS1_Dec_Max [s] = \frac{Speed [rpm] \times Rampx_Dec_Time_max [s]}{Rampx_speed [rpm]}$$

$$SS1_Dec_Min [s] = \frac{Speed [rpm] \times (Rampx_Dec_Time_min [s] - SS1_td1 [s])}{Rampx_speed [rpm]}$$

where Speed[rpm] is the speed at the time of the calculation. SS1_Dec_Max and SS1_Dec_Min are the time from ramp start (points A and B) to where speed should be zero (points C and D). Rampx_speed is the nominal speed for the used ramp set. See the figure below. At any given point during the ramp monitoring, the actual value of monitoring is calculated from the slope connecting the respective points. The area outside the permitted speed range during ramp monitoring is shaded.

NOTICE

Use of ramp monitoring is not recommended when only proximity sensors are used as speed sensor.

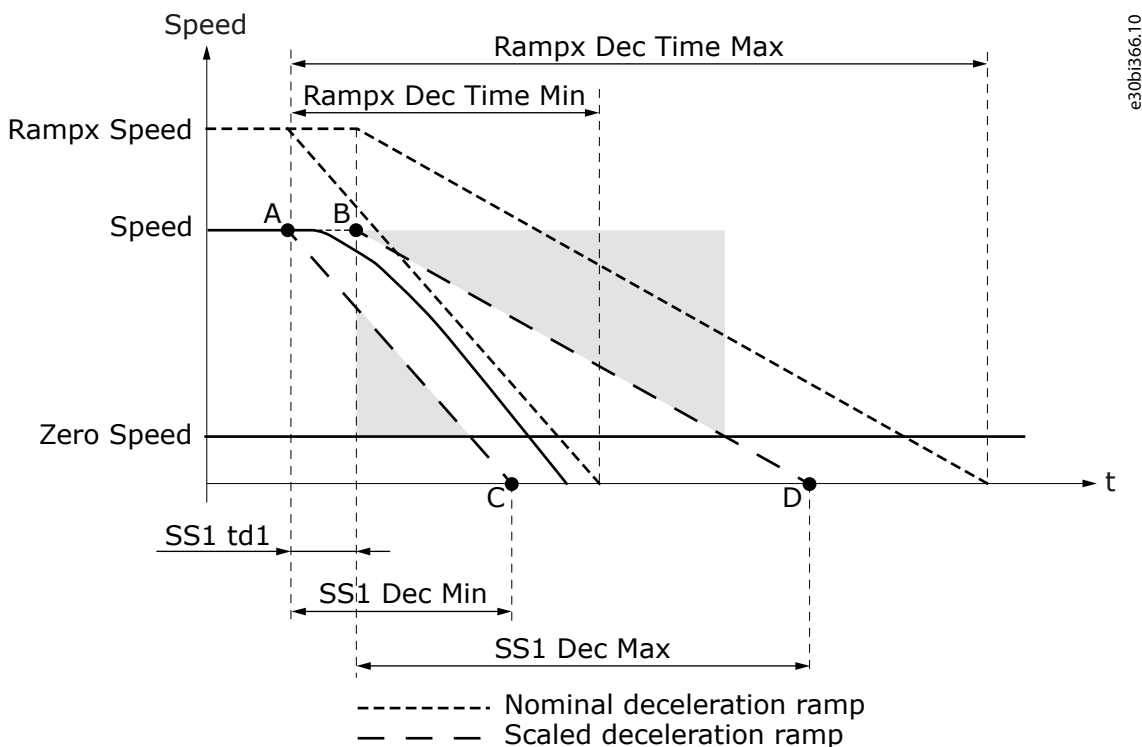

Illustration 26: Deceleration Ramp, the SS1 Function as an Example

A	Start of the minimum deceleration ramp	C	End of the minimum deceleration ramp
B	Start of the maximum deceleration ramp	D	End of the maximum deceleration ramp

Ramp monitoring does not continue in the safe speed range of the safe monitoring function. For example, for the SLS function, the maximum ramp value is limited to the selected SLS limit. This can be noted, for example, with long SLS td2 delays. The minimum ramp monitoring stops when the monitoring value would be below the selected SLS limit.

The acceleration ramps are valid only for the SSR function. The acceleration ramps are defined in the same way as deceleration ramps. A nominal speed value (shared with the deceleration ramp) and two time values that represent the maximum and minimum time that the ramping is permitted to take. The actual monitored ramps are calculated when ramp monitoring starts.

$$SSR_Acc_max [s] = \frac{(SSR_Min_Limit [rpm] - Speed [rpm]) \times Ramp_Acc_Time_Min [s]}{Rampx_speed [rpm]}$$

$$SSR_Acc_min [s] = \frac{(SSR_Min_Limit [rpm] - Speed [rpm]) \times (Ramp_Acc_Time_Min [s] - SSR_td1 [s])}{Rampx_speed [rpm]}$$

where Speed is the speed at the time of the calculation. SSR_Acc_Max and SSR_Acc_Min are the time from ramp start (A and B) where speed should be at the monitored minimum limit speed (C and D). Rampx_speed is the nominal speed for the ramp set. At any given point during the ramp monitoring the actual value of monitoring is calculated from the slope connecting the respective points.

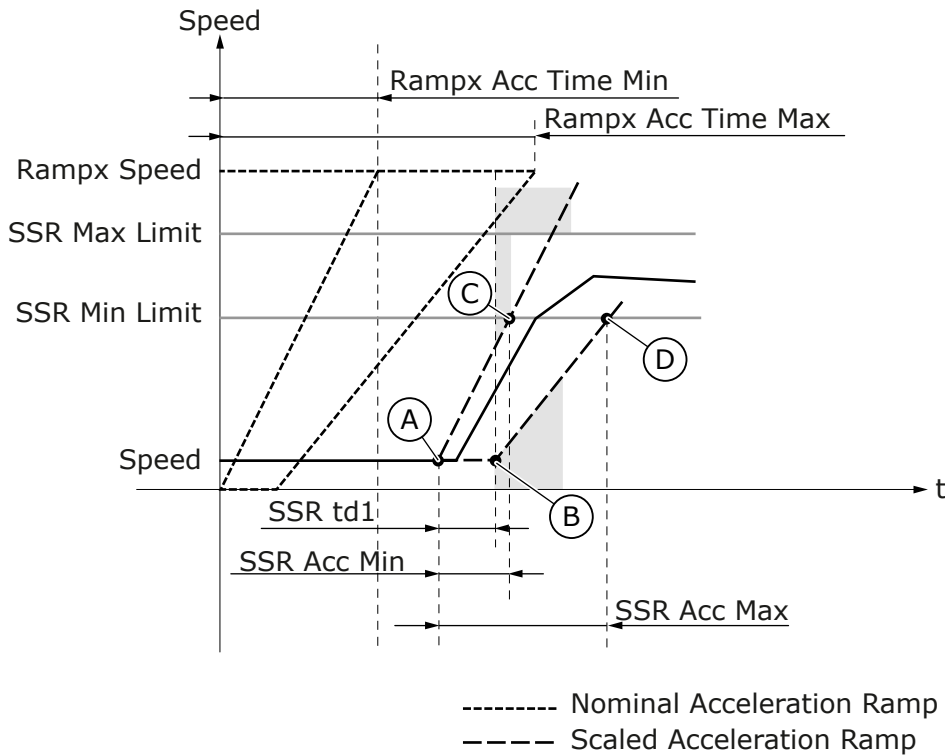

Illustration 27: Acceleration Ramps, the SSR Function as an Example

A	Start of the minimum acceleration ramp	C	End of the minimum deceleration ramp
B	Start of the maximum acceleration ramp	D	End of the maximum deceleration ramp

NOTICE

The response to a ramp violation is the STO(+SBC) function for safe stopping functions, and the SQS function for safe monitoring functions.

6.2 Safe Stopping Functions

6.2.1 Introduction to the Safe Stopping Functions

The safe stopping functions are used to start and monitor the stopping of the motor. The safe stopping functions do not take into account the rotation direction of the motor when they are in the optional zero speed or the ramp monitoring mode. The SOS function is an exception, it takes into account the rotation direction of the motor.

The priority of the safe stopping functions from the highest to the lowest:

1. The STO function
2. The SQS function

- 3. The SS1 function
- 4. The SS2 function

When a higher priority function is requested while a lower priority function is active, it interrupts the lower priority function and becomes active. The higher priority function behaves as it is parameterized. The lower priority function stays active, but it stops monitoring.

When a lower priority function is requested while a higher priority function is active, the lower priority function does not become active.

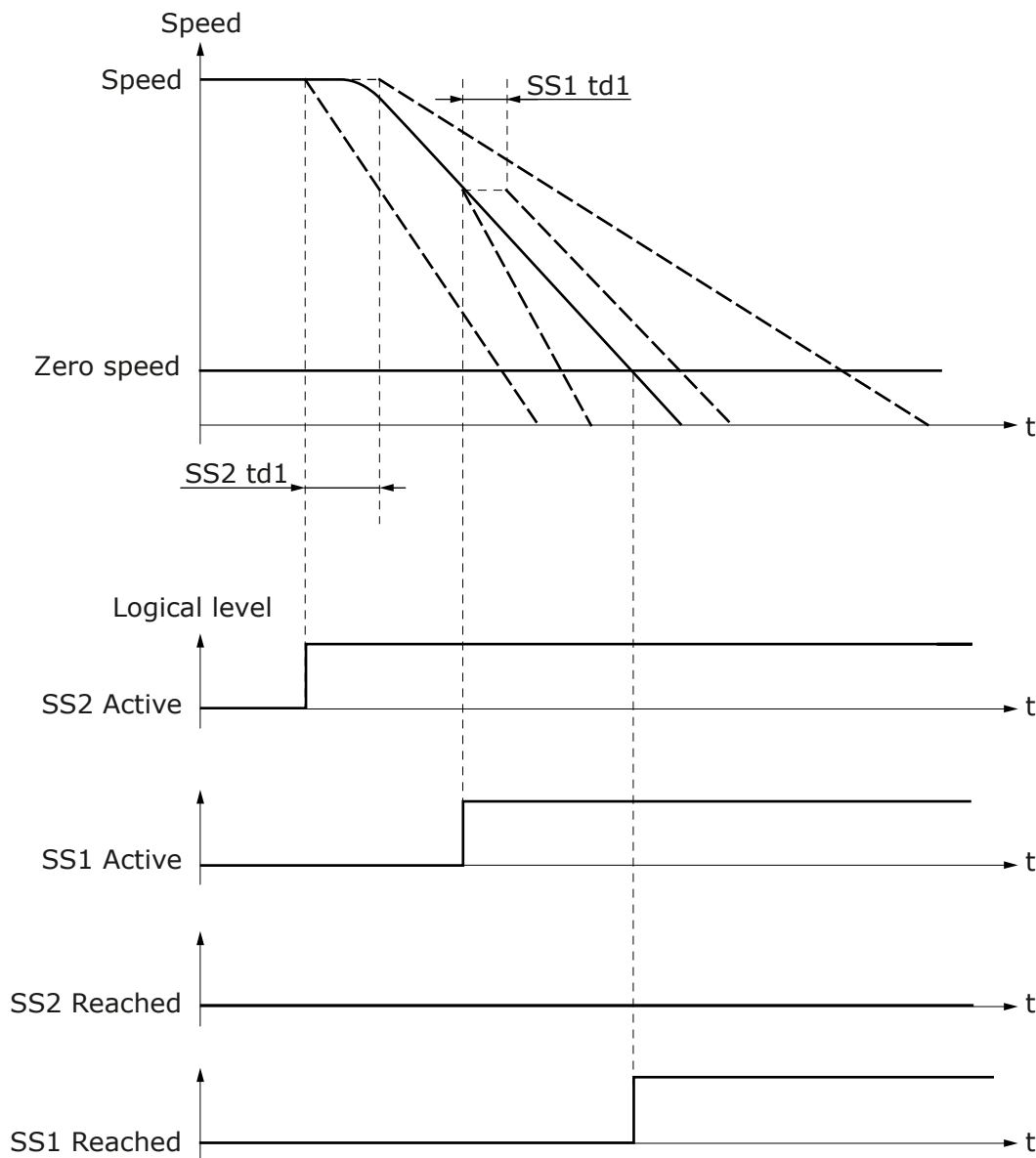

e30b1354.10

Illustration 28: The SS1 Function Interrupts the SS2 Function. The Signal SS2 Active Stays Active but the Operation Stops

If a higher priority function interrupts a lower priority function, both functions must be not requested for the STO(+SBC) or the SOS function to be deactivated.

If the SS1 function is requested when the SOS function is active (if, for example, the SS2 function is reached), the SS1 function activates the STO function after SS1 td2, without ramp or time monitoring.

6.2.2 STO - Safe Torque Off and SBC - Safe Brake Control

6.2.2.1 Introduction to the STO and SBC Functions

The Safe Torque Off (STO) safety function allows the drive output to be disabled so that the drive cannot generate torque to the motor shaft.

The STO function can be used together with the Safe Brake Control (SBC) safety function. The SBC function provides a safe output with which it is possible to control an external brake.

The STO function fulfills the stop category 0 of the standard IEC-60204-1.

For effects of the STO function on the AC drive, see the VACON®NXP OPTAF STO Board Manual.

Things that can activate the STO(+SBC) function:

- An external request
- A violation of another safety function (as SQS or as a safe stopping function violation response)
- A fault detected by the internal diagnostics of the Advanced safety option board

The parameters of the STO and SBC safety functions are described in [8.4 STO and SBC Parameters](#).

6.2.2.2 The STO Function Used without the SBC Function

When there is an external request for the STO function, or a violation of another safe stopping function, the STO function is activated immediately.

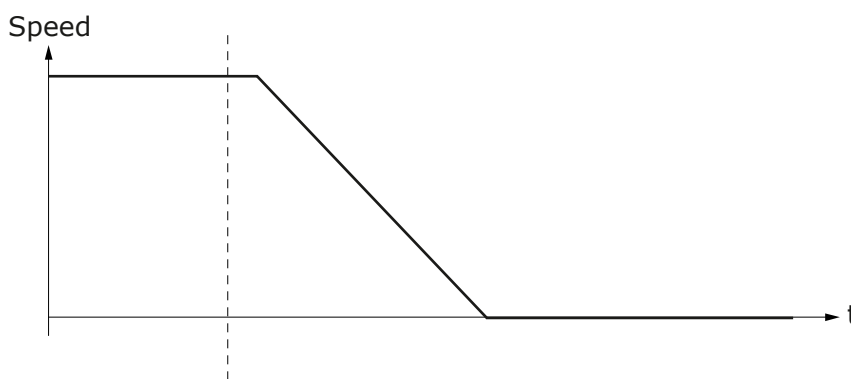

e30bi387.10

Illustration 29: The STO Function

The STO output of the Advanced safety option board is connected to the STO option board that handles the operation of the STO function in the drive. When the STO function is active, it disables the drive output. Then the drive cannot generate torque to the motor shaft.

6.2.2.3 The STO Function Used with the SBC Function

When the STO function is used with the SBC function, the behavior of the STO output, the STO signals, the SBC output, and the SBC signals depends on the values of the SBC parameters. The parameter SBC Order defines which safety function becomes active first. The second safety function becomes active after the time that is set in SBC t1.

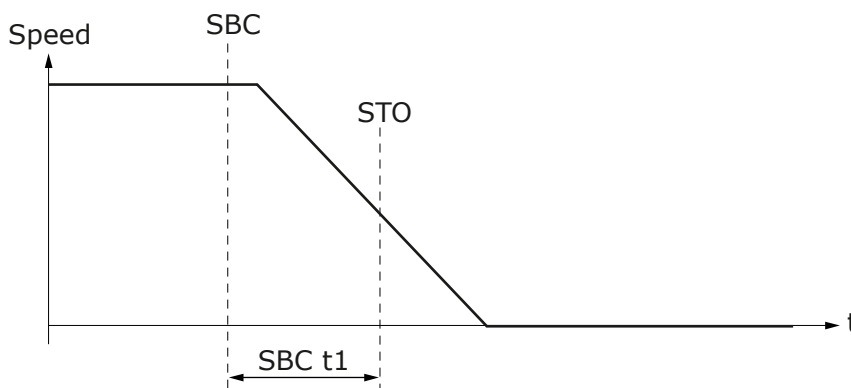

e30bi388.10

Illustration 30: STO Behaviour with SBC Order = SBC First

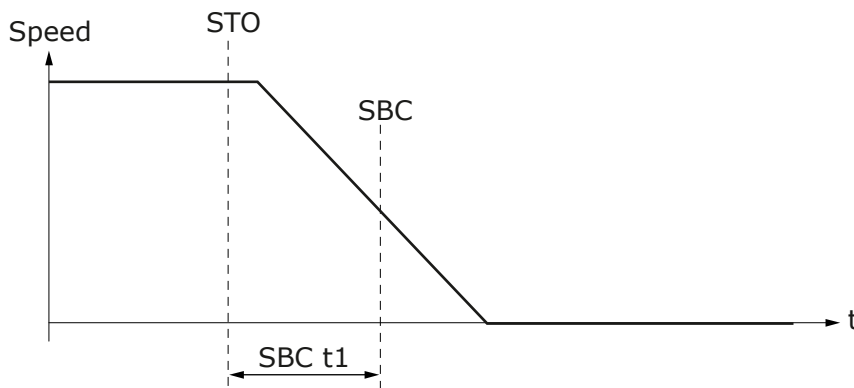

e30bi389.10

Illustration 31: STO Behaviour with SBC Order = STO First

Table 29: The Behavior of the STO and SBC Functions when SBC Order = STO First

STO requested by	SBC Speed = 0	SBC Speed > Zero Speed
External request	STO at the request. SBC delayed by SBC t1 compared to STO.	Invalid configurations
The SS1 or SQS-SS1 safety function	Time monitoring: STO after SQS t1 or SS1 t1. Zero speed monitoring: STO when speed below zero speed and SQS td2 or SS1 td2 expires. SBC delayed by SBC t1 compared to STO.	Invalid configurations
Violation of SS1, SS2, or SQS or resettable fault	STO at the fault moment. SBC delayed by SBC t1 compared to STO.	Invalid configurations

Table 30: The Behavior of the STO and SBC Functions when SBC Order = SBC First

STO initiated by	SBC Speed = 0	SBC Speed > Zero Speed
External request	SBC at the request. STO delayed by SBC t1 compared to SBC.	SBC at the request, STO delayed by SBC t1 compared to SBC.
The SS1 or SQS-SS1 safety function	Time monitoring: SBC after SQS t1 or SS1 t1. Zero speed monitoring: SBC when speed below Zero Speed and SQS td2 or SS1 td2 expires. STO always delayed by SBC t1 compared to SBC.	Time monitoring: SBC after SQS t1/SS1 t1 or when speed below SBC Speed. Zero speed monitoring: SBC when speed below SBC Speed. STO delayed by SBC t1 compared to SBC.
Violation of SS1, SS2, or SQS or resettable fault	STO and SBC at the fault moment. SBC t1 not used.	STO and SBC at the fault moment. SBC t1 not used.

After acknowledgment or reset, the STO and the SBC functions are deactivated at the same time. Other brake controlling systems can be used to make sure that sufficient torque has been generated to the motor shaft before the brake is released.

6.2.2.4 The STO and SBC Signals

It is possible that the Active and Reached signals that are mentioned in this chapter are not always available in all interfaces.

NOTICE

The availability of the signals over safe fieldbus depends on the fieldbus protocol that you use. Refer to chapter Safe fieldbuses for more information.

Table 31: The STO and SBC Signals

Signal	Activation and deactivation of the signal	Description
STO Active	<p>Activation:</p> <ul style="list-style-type: none"> STO safety function is requested externally or from another safety function. OR Fault detected in the Advanced safety option board <p>Deactivation (manual acknowledgment):</p> <ul style="list-style-type: none"> Acknowledgment signal received <p>Deactivation (automatic acknowledgment):</p> <ul style="list-style-type: none"> STO request ends <p>Deactivation (fault situation):</p> <ul style="list-style-type: none"> Reset signal is given after a fault situation is cleared and reset conditions are valid 	The signal indicates if STO function is being executed.
STO Reached	<p>This signal corresponds to the state of STO output on the Advanced safety option board. The actual state of the output is reversed compared to the STO Reached signal. If STO Reached is active, the STO output is inactive.</p> <p>Activation:</p> <ul style="list-style-type: none"> Immediately with STO Active (SBC Order = STO first or SBC is not used, or fault situation) OR After SBC t1 (SBC Order = SBC first) <p>Deactivation (manual acknowledgment):</p> <ul style="list-style-type: none"> Acknowledgment signal received when STO request has ended. <p>Deactivation (automatic acknowledgment):</p> <ul style="list-style-type: none"> STO request is deactivated. <p>Deactivation (fault situation)</p> <ul style="list-style-type: none"> Reset signal is given after a fault situation is cleared and reset conditions are valid. 	The signal indicates if the STO output is activated.
SBC Reached	<p>Signal corresponds to the state of SBC output on the Advanced safety option board. The actual state of the output is reversed compared to the SBC Reached signal. If SBC Reached is active, the SBC output is inactive.</p> <p>Activation:</p> <ul style="list-style-type: none"> Immediately with STO_Active (SBC Order = SBC first) OR After SBC t1 (SBC Order = STO first) <p>Deactivation (manual acknowledgment):</p> <ul style="list-style-type: none"> acknowledgment signal received when STO request has ended <p>Deactivation (automatic acknowledgment):</p> <ul style="list-style-type: none"> STO request is deactivated. <p>Deactivation (fault situation):</p> <ul style="list-style-type: none"> Reset signal is given after a fault situation is cleared and reset conditions valid 	The signal indicates if the SBC output is activated.
STO & SBC reached	<p>Activation:</p> <ul style="list-style-type: none"> When both SBC Reached and STO Reached are activated. <p>Deactivation:</p> <ul style="list-style-type: none"> When either SBC Reached or STO Reached is deactivated. <p>See STO and SBC signals above.</p>	Combination of STO and SBC reached signals.

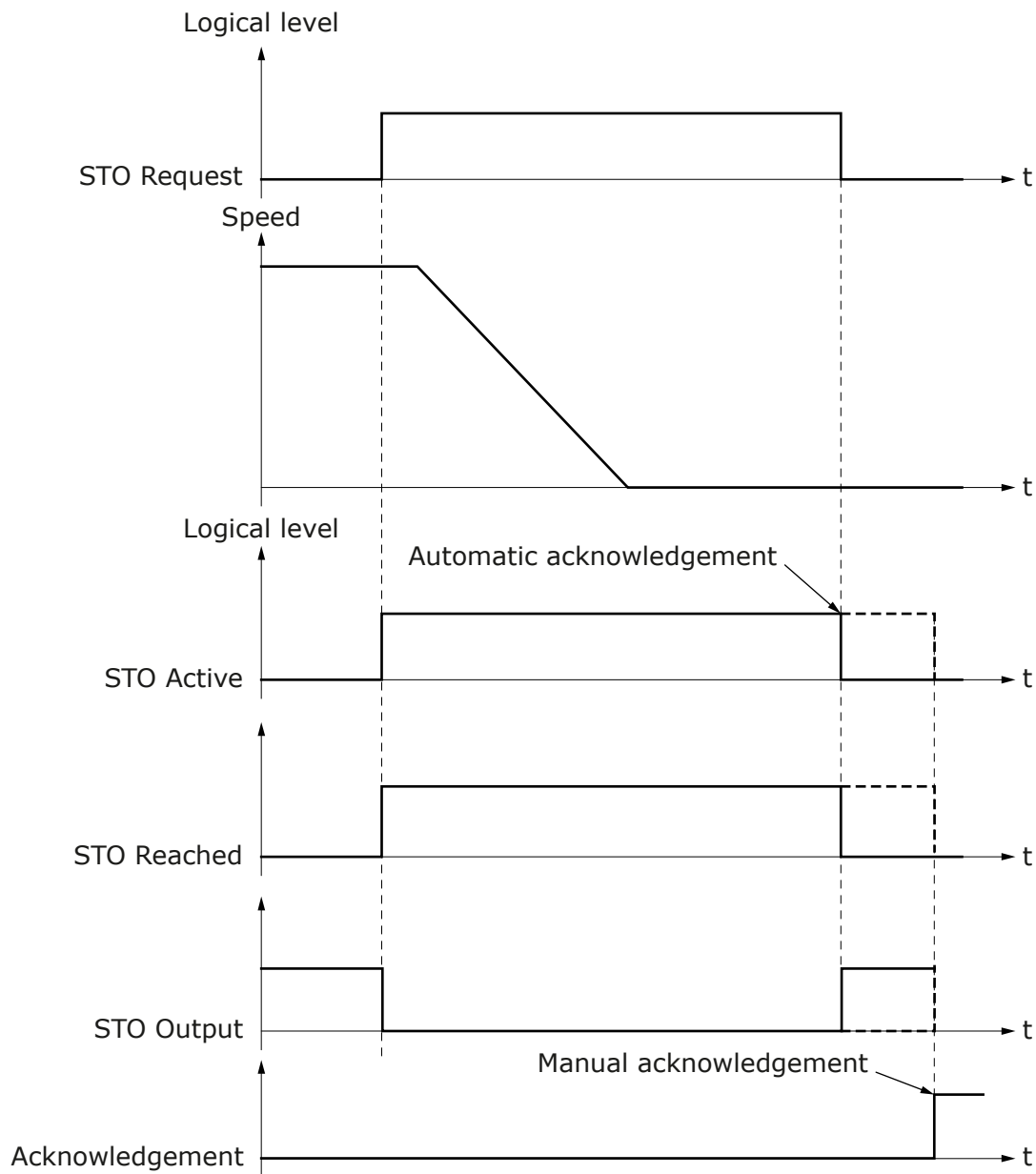

e30bi338.10

Illustration 32: The STO Signals when the SBC Function is not Used

e30bi339,10

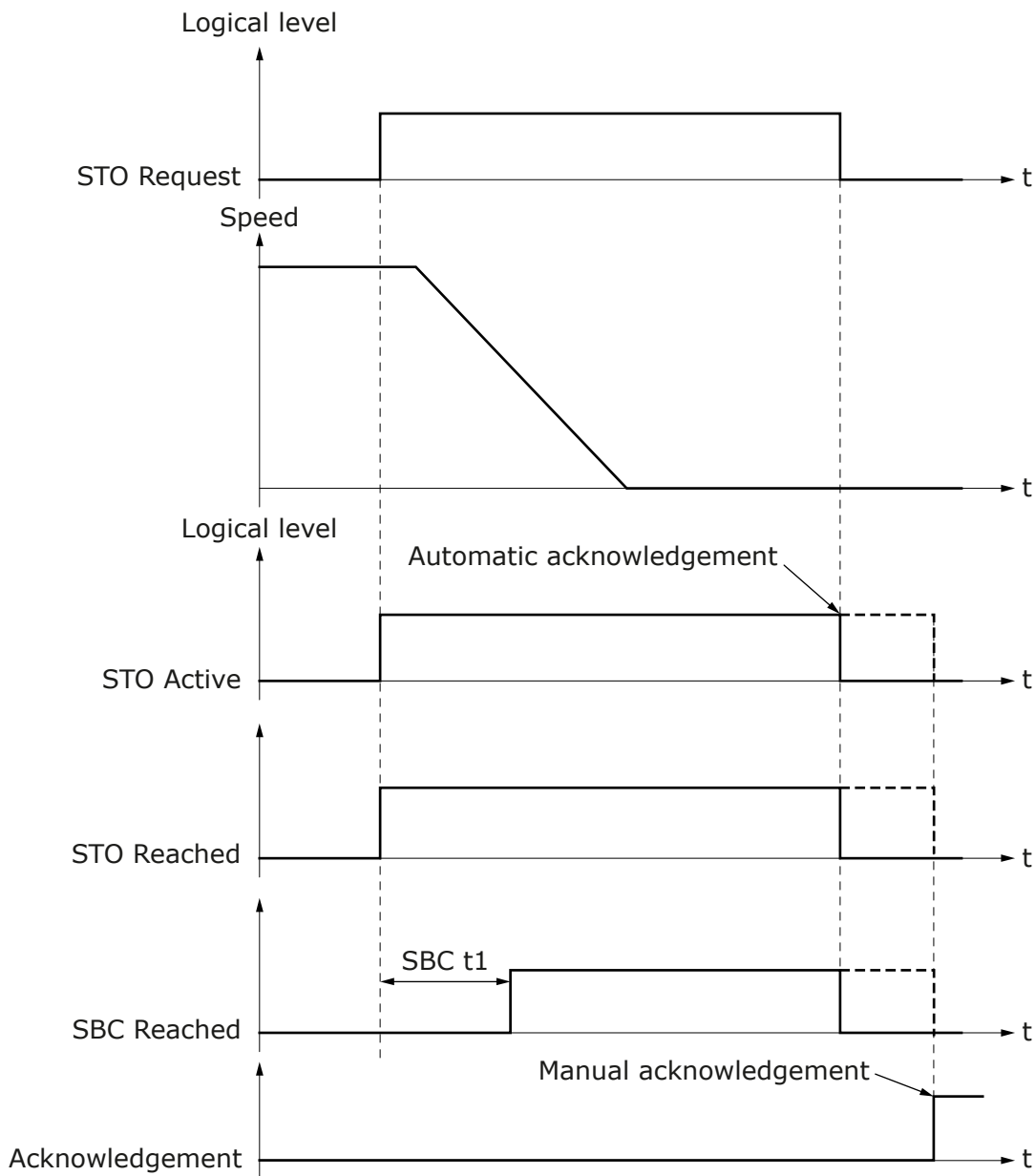
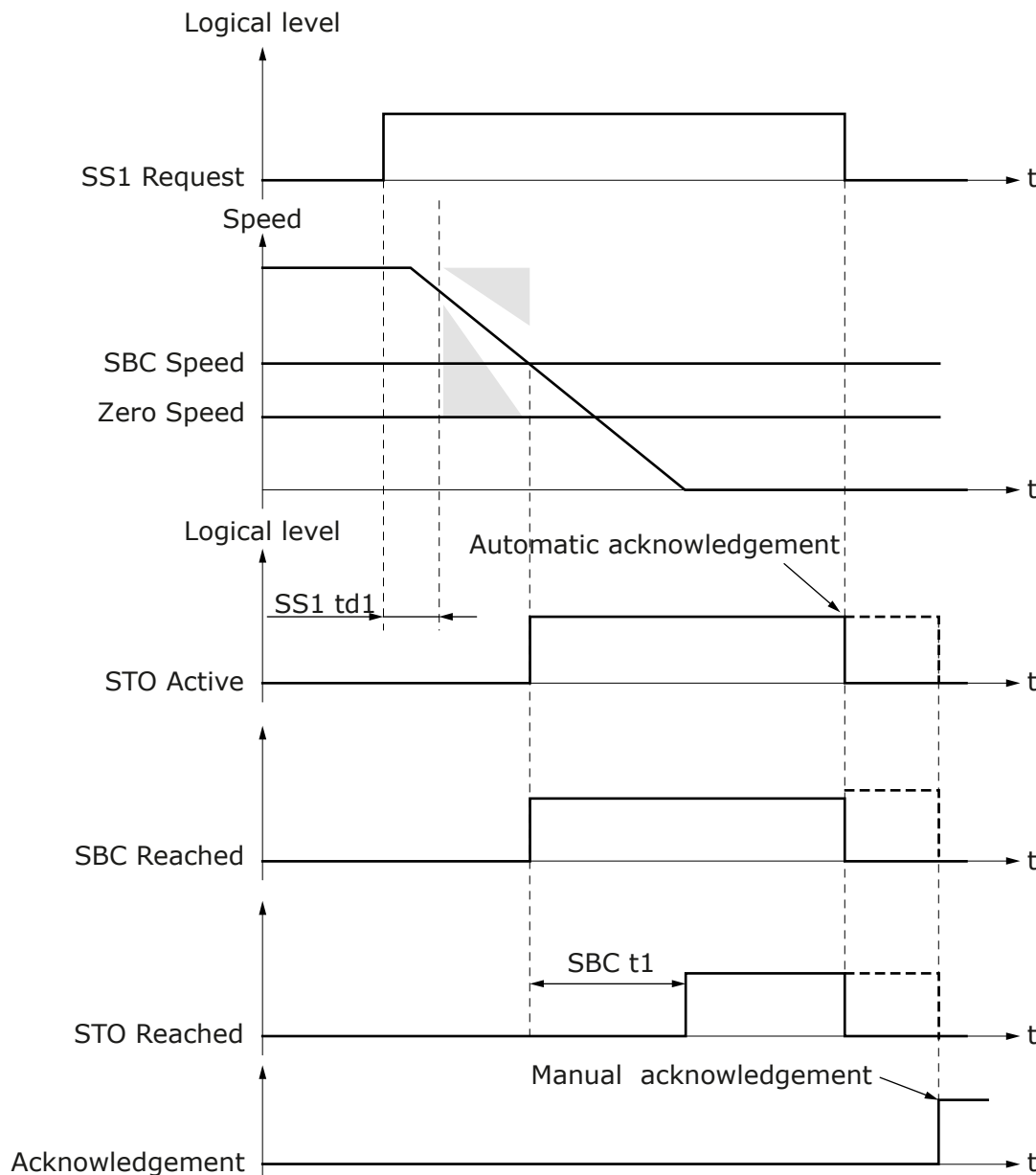

Illustration 33: The STO and SBC Signals when the SBC Function is Used, SBC Order = STO First, and the STO Function is Requested



e30bi340.10

Illustration 34: The STO and SBC Signals when the SBC Function is Used, and the SS1 Function is Requested. SBC Order = SBC First. The SS1 Signals are Omitted from the Figure.

6.2.3 SS1 - Safe Stop 1

6.2.3.1 Introduction to the SS1 Function

The Safe Stop 1 (SS1) safety function monitors the motor deceleration and activates the STO(+SBC) function. Select the activation settings of the STO(+SBC) function with the SS1 parameters.

The SS1 function can operate in one of the three monitoring modes:

- Time monitoring mode
- Time + zero speed monitoring mode
- Time + zero speed + ramp monitoring mode

The SS1 function can activate the STO function:

- When an application-specific time delay has passed (Time monitoring).
- When the speed reaches zero speed (Zero speed monitoring).

The STO function can also become active as a violation response, when the speed does not follow the set deceleration ramp (Ramp monitoring).

The SS1 function fulfills the stop category 1 of the standard IEC-60204-1.

The parameters of the SS1 safety function are described in [8.5 SS1 Parameters](#).

6.2.3.2 Time Monitoring

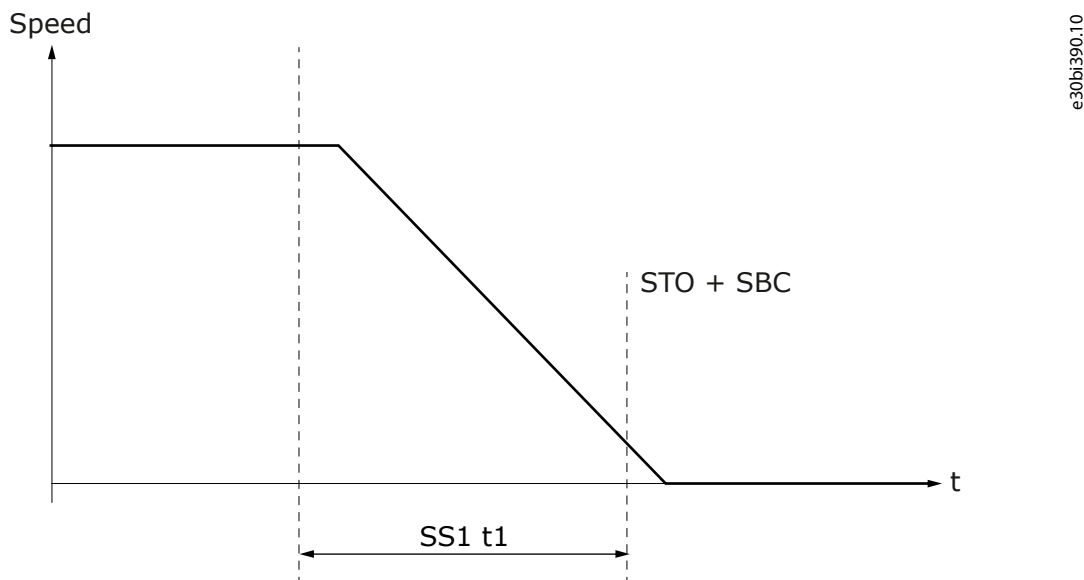

Illustration 35: The SS1 Function in the Time Monitoring Mode

The time monitoring mode is always used when SS1 is active. In the time monitoring mode, the STO function is activated when the time indicated by parameter SS1 t1 has elapsed. The SS1 t1 timer starts when the SS1 function starts its operation.

If the SBC function is used and the value of the parameter SBC Speed is set to above zero, the STO(+SBC) becomes active after SS1 t1, or when the speed goes below SBC Speed, whichever is valid first.

6.2.3.3 Zero Speed Monitoring

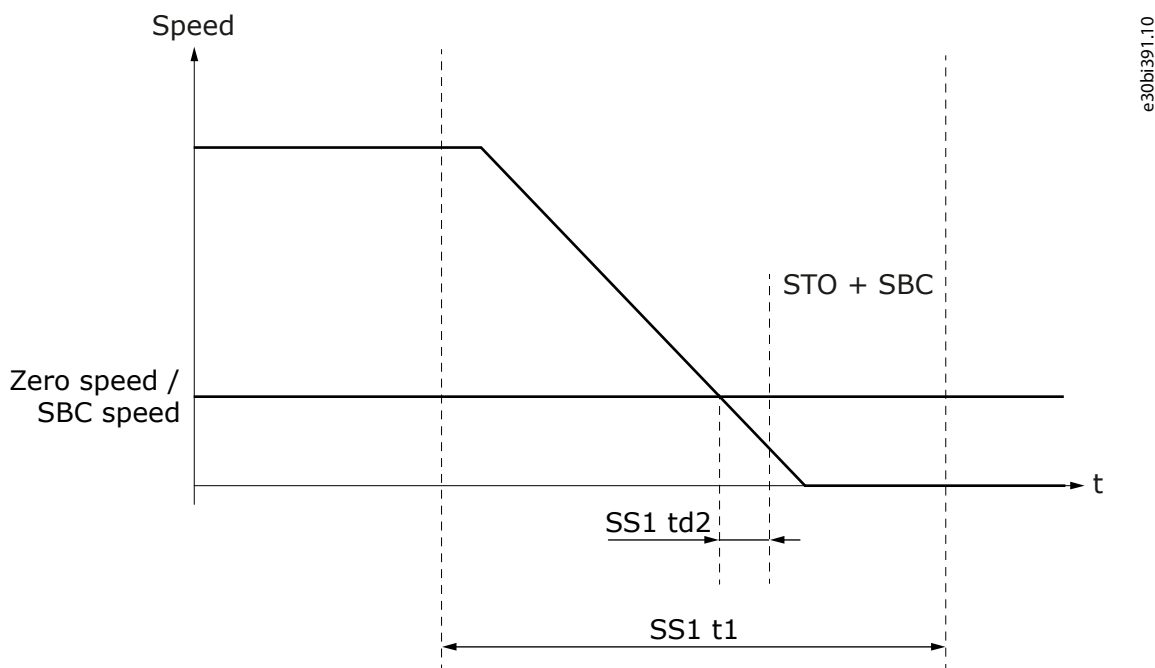

Illustration 36: The SS1 Function in the Time + Zero Speed Monitoring Mode

When zero speed monitoring is used, time monitoring is also used. Zero speed monitoring monitors if the motor stops. The stopping of the motor is determined by parameter Zero Speed. When zero speed monitoring is used, the speed going below the zero speed starts a delay time set in SS1 td2 after which the SS1 function is reached. When the SS1 function is reached, the STO function becomes active. The SS1 function must be reached before the time that is set in SS1 t1 elapses. If SS1 t1 elapses first, the STO function is activated as a violation response, not as a regular STO safety function.

If the SBC function is used, the moment when the brake output becomes active depends on the parameterization of the SBC function. See [6.2.2.3 The STO Function Used with the SBC Function](#).

6.2.3.4 Ramp Monitoring

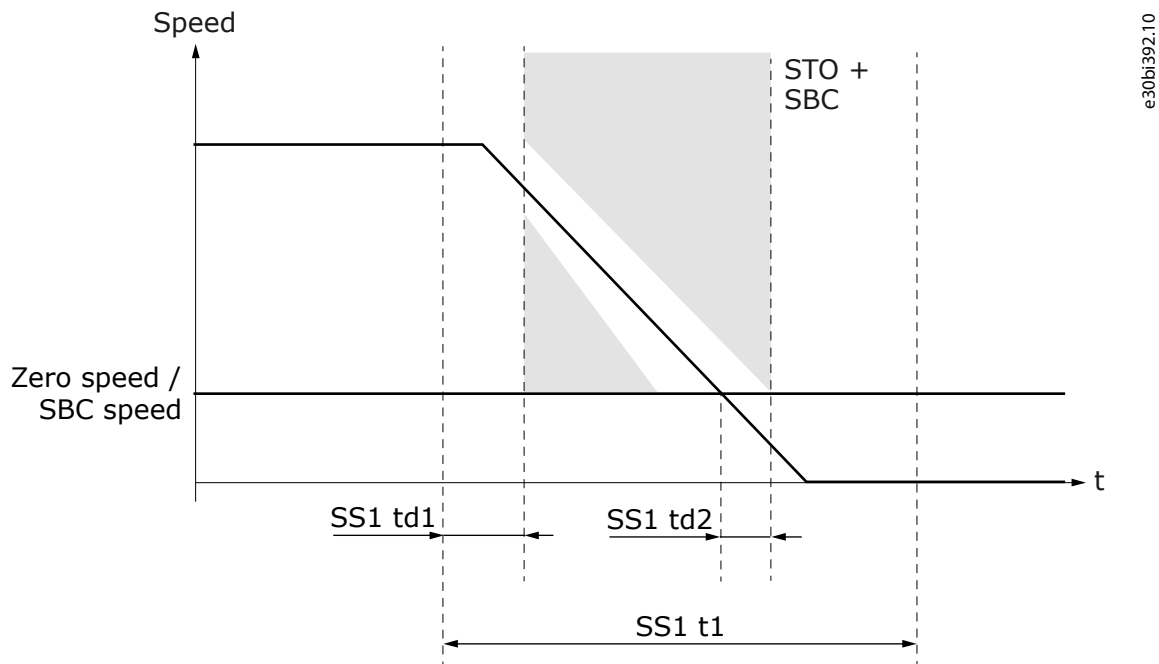

Illustration 37: The SS1 Function in the Time + Zero Speed + Ramp Monitoring Mode

When ramp monitoring is used, zero speed monitoring and time monitoring are also used. Ramp monitoring monitors that the deceleration speed obeys the set deceleration ramp. Select the monitored ramp with parameter SS1 Ramp Monitoring. The ramp can be static or dynamically selected by a digital input or a fieldbus. It is possible to monitor the minimum ramp, the maximum ramp, or both these ramps.

The ramp monitoring starts after the time delay that is set with SS1 td1 has passed. SS1 td1 starts when the SS1 function starts its operation. The ramp monitoring ends when the SS1 function is reached. If the speed does not obey the parameterized ramp during the monitoring, the STO function becomes active as a violation response.

When using dynamic ramp from digital input or fieldbus, the monitored ramp is determined at the moment when the SS1 function is requested. The changes that are made after this do not affect the operation of the function.

6.2.3.5 The SS1 Signals

It is possible that the Active and Reached signals that are mentioned in this chapter are not always available in all interfaces.

NOTICE

The availability of the signals over safe fieldbus depends on the used fieldbus protocol. Refer to chapter Safe fieldbuses for more information.

Table 32: The SS1 Signals

Signal	Activation and deactivation of the signal	Description
SS1 Active	Activation: <ul style="list-style-type: none"> SS1 is requested and starts execution. Deactivation (manual acknowledgment):	The signal indicates if SS1 function is being executed.

Signal	Activation and deactivation of the signal	Description
	<ul style="list-style-type: none"> Acknowledgment signal received after SS1 is not requested. Deactivation (automatic acknowledgment): <ul style="list-style-type: none"> SS1 request ends. Deactivation (SS1 violation situations): <ul style="list-style-type: none"> Reset signal received after SS1 had detected a violation and SS1 has been acknowledged (implicitly and explicitly). 	
SS1 Reached	Only activated when SS1 has not detected any violations. Activation: <ul style="list-style-type: none"> Time SS1_t1 elapses (only time monitoring used). OR Speed is below zero speed for time SS1_td1 (zero speed monitoring used). Deactivation (manual acknowledgment): <ul style="list-style-type: none"> SS1 is acknowledged after being reached successfully. Deactivation (automatic acknowledgment): <ul style="list-style-type: none"> SS1 was reached successfully and SS1 request ends. Deactivation (higher priority function is requested): <ul style="list-style-type: none"> STO or SQS is requested. 	The signal indicates if SS1 function has been reached successfully.

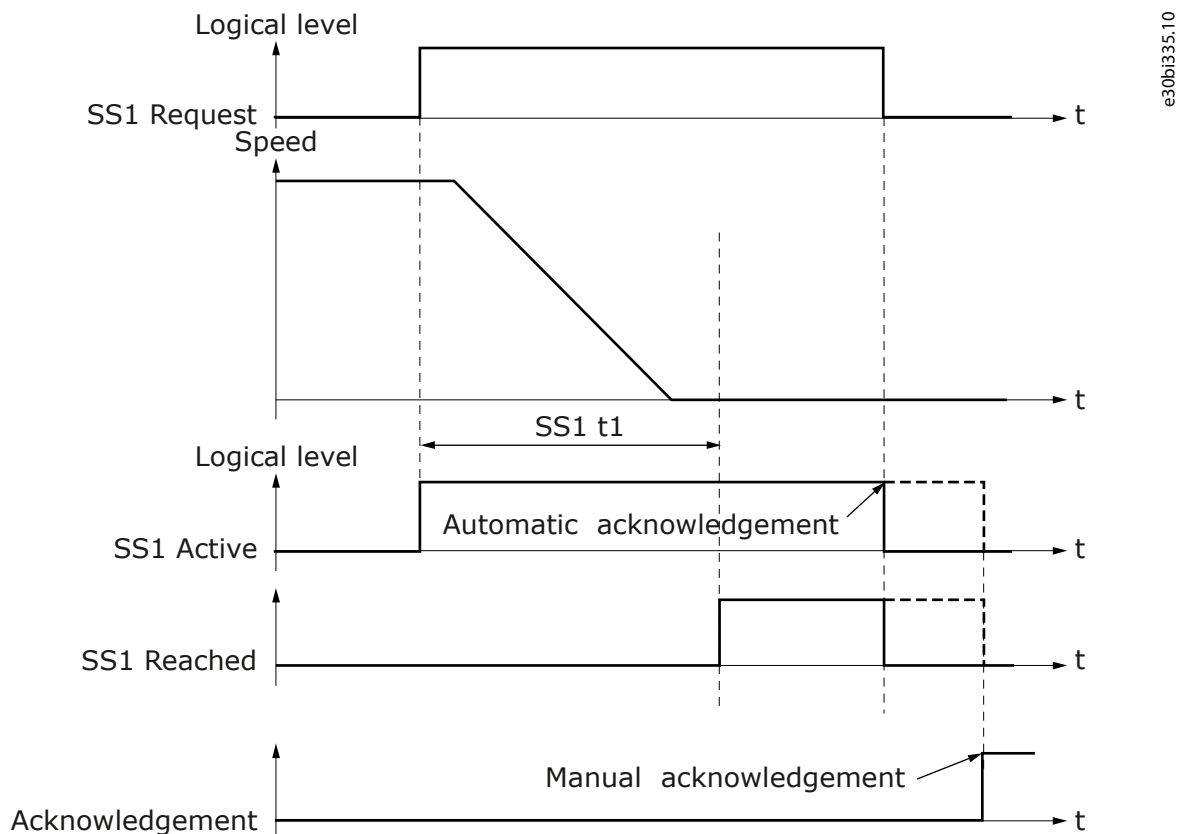
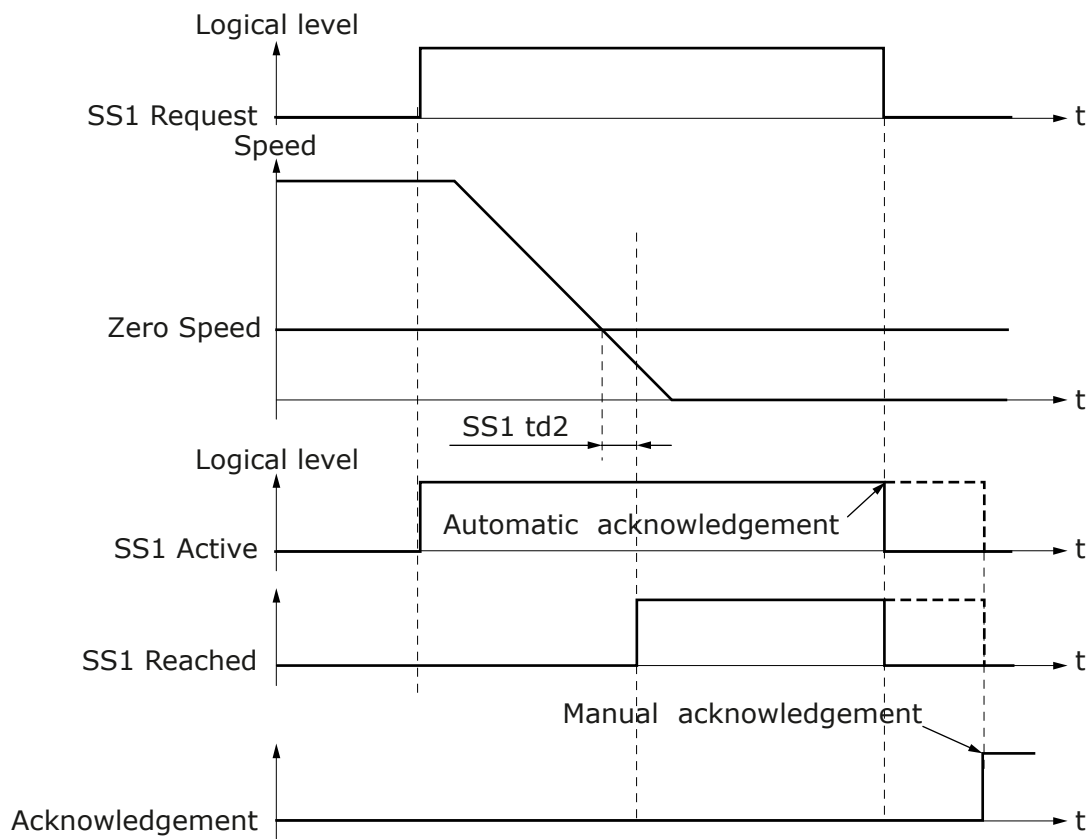

Illustration 38: The SS1 Signals in the Time Monitoring Mode



e30b1336.10

Illustration 39: The SS1 Signals in the Zero Speed Monitoring Mode

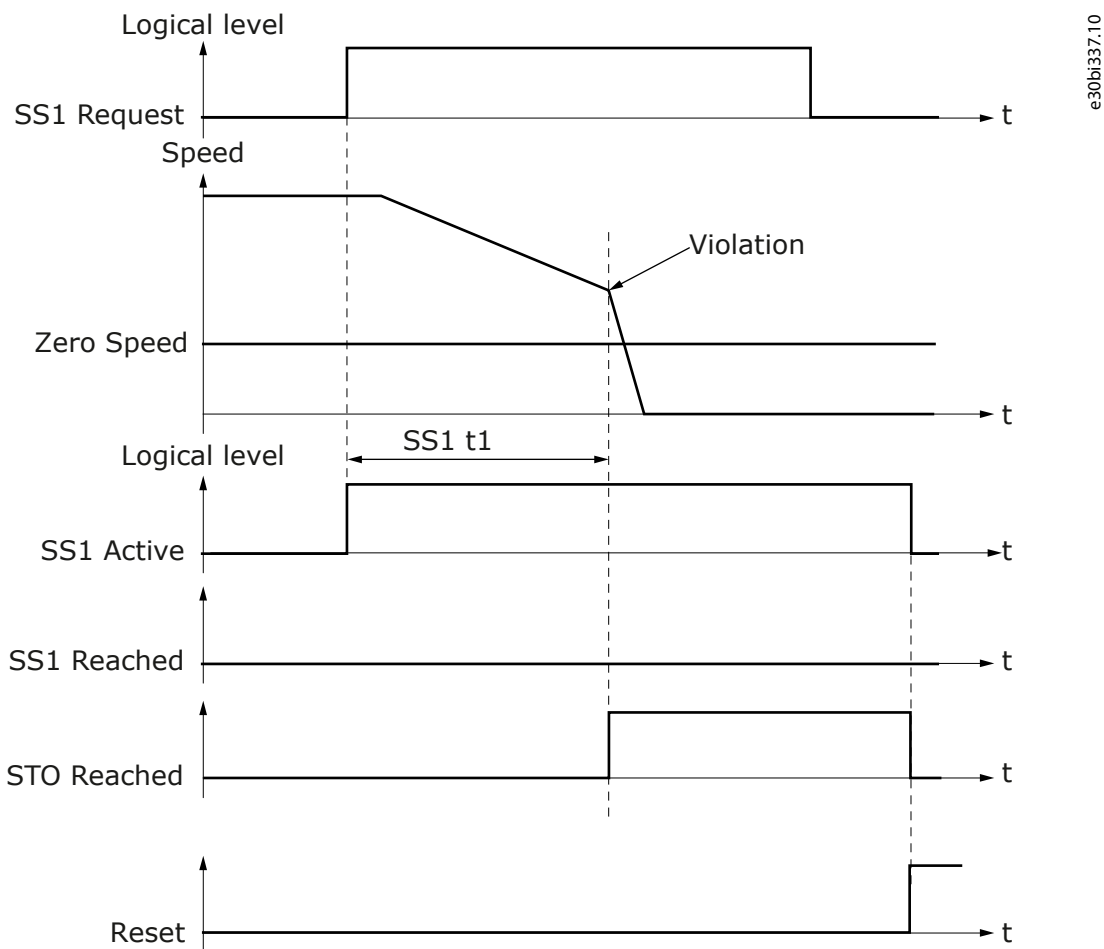

Illustration 40: The SS1 Signals in Zero Speed Monitoring Mode in a Violation Case. The STO Function without SBC.

6.2.4 SS2 - Safe Stop 2 and SOS - Safe Operating Stop

6.2.4.1 Introduction to the SS2 and SOS Functions

The Safe Stop 2 (SS2) safety function starts the motor deceleration and activates the SOS function.

The SS2 function can operate in one of the three monitoring modes:

- Time monitoring mode
- Time + zero speed monitoring mode
- Time + zero speed + ramp monitoring mode

The SS2 function can activate the SOS function:

- When an application-specific time delay has passed (Time monitoring)
- When the speed reaches zero speed (Zero speed monitoring)

The violation response of the SS2 function is the STO(+SBC) function. During ramp down, it is possible to monitor the deceleration. If there is a violation in the ramp monitoring of the SS2 function, or if zero speed is not reached, it activates the STO(+SBC) function as a violation response.

The SOS safety function keeps the drive output active and monitors the positions of the motor shaft. A violation of the position monitoring of the SOS function activates the STO(+SBC) function.

The SS2 and SOS functions fulfill the stop category 2 of the standard IEC-60204-1.

The parameters of the SS2 and SOS safety functions are described in [8.6 SS2 and SOS Parameters](#).

NOTICE

The SS2 safety function can be used only with Sin/Cos encoders.

6.2.4.2 Time Monitoring

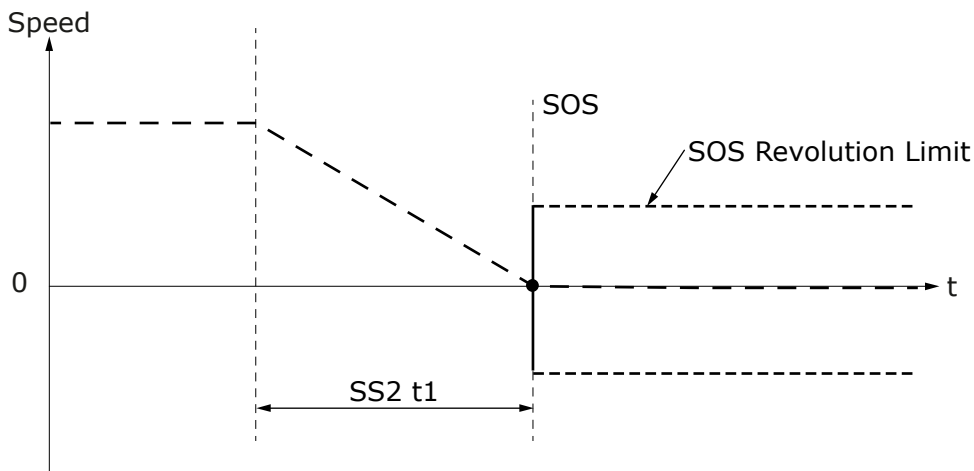

e30b1393.10

Illustration 41: The SS2 Function in the Time Monitoring Mode

The time monitoring mode is always used when SS2 is active. The SOS function becomes active when the time that is set with parameter SS2 t1 has passed. The SS2 t1 timer starts when the SS2 function starts its operation.

6.2.4.3 Zero Speed Monitoring

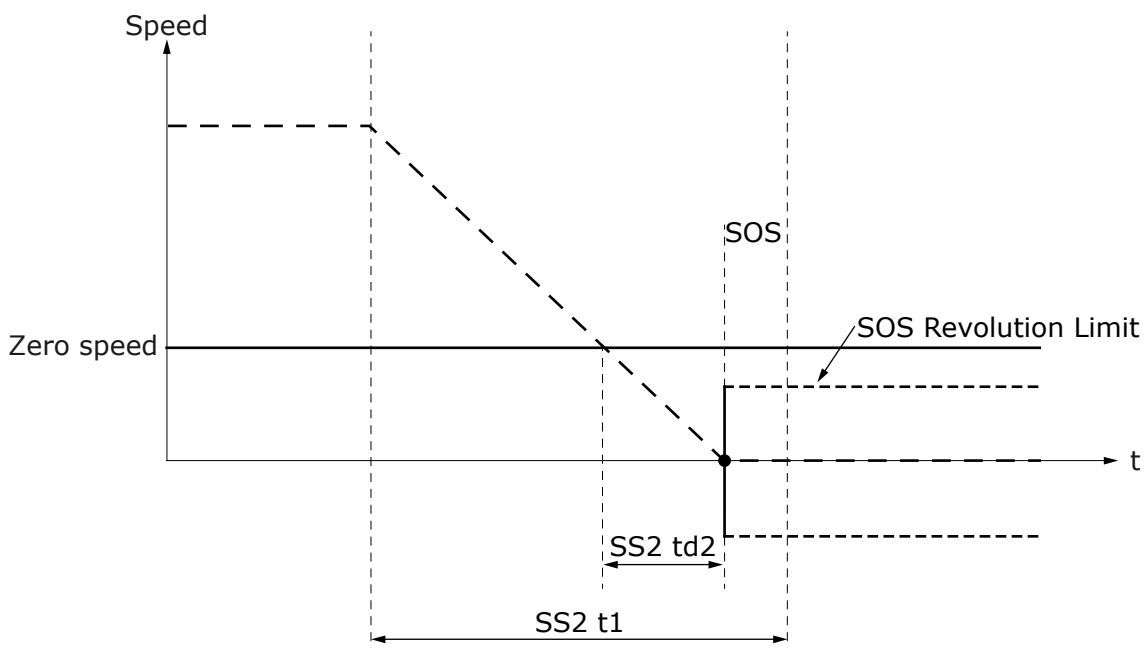

e30b1394.10

Illustration 42: The SS2 Function in the Zero Speed Monitoring Mode

When zero speed monitoring is used, time monitoring is also used. Zero speed monitoring monitors if the motor stops. The stopping of the motor is determined by parameter Zero Speed. When zero speed monitoring is used, the speed going below the zero speed starts a delay time set in SS2 td2 after which the SS2 function is reached. When the SS2 function is reached, the SOS function becomes active. The SS2 function must be reached before the time that is set in SS2 t1 elapses. If SS2 t1 elapses first, the STO(+SBC) function is activated as a violation response.

6.2.4.4 Ramp Monitoring

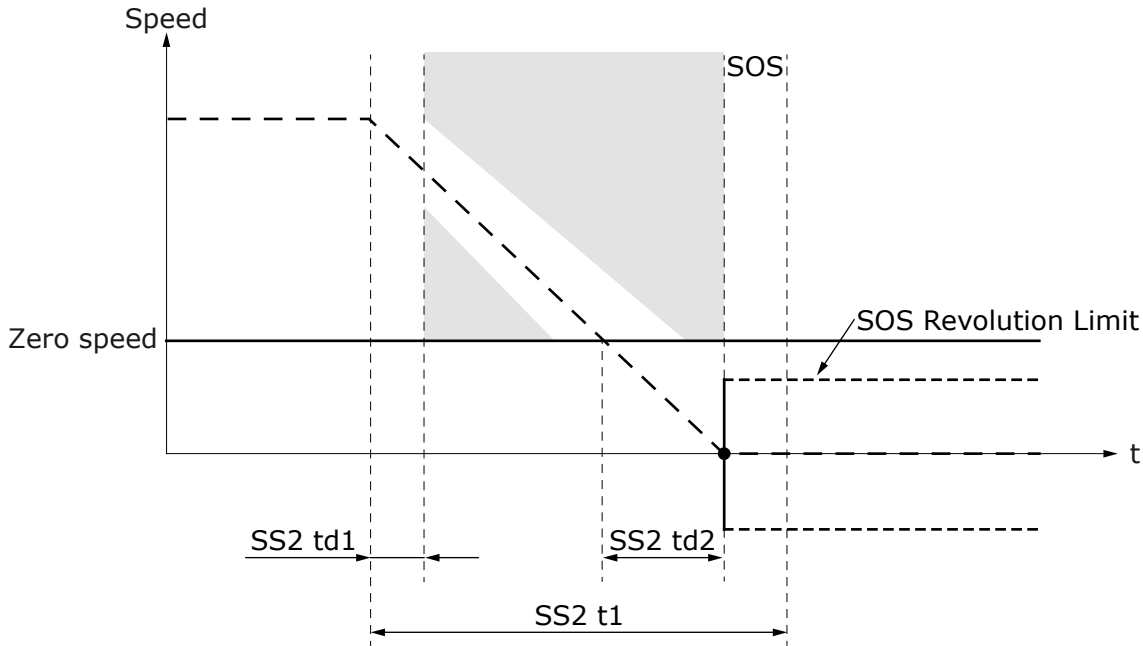

e30b1395.10

Illustration 43: The SS2 Function in the Ramp Monitoring Mode

When ramp monitoring is used, zero speed monitoring and time monitoring are also used. Ramp monitoring monitors that the deceleration speed obeys the set deceleration ramp. Select the monitored ramp with parameter SS2 Ramp Monitoring. The ramp can be static or dynamically selected by a digital input or a fieldbus. It is possible to monitor the minimum ramp, the maximum ramp, or both these ramps.

The ramp monitoring starts after the time delay that is set with SS2 td1 has passed. SS2 td1 starts when the SS2 function starts its operation. The ramp monitoring ends when the SS2 function is reached. If the speed does not obey the parameterized ramp during the monitoring, the STO(+SBC) function becomes active as a violation response.

When using dynamic ramp from digital input or fieldbus, the monitored ramp is determined at the moment when the function is requested. The changes that are made after this do not affect the operation of the function.

6.2.4.5 The SOS Safety Function

When the SOS safety function is active, it monitors the rotation of the motor shaft. Use parameter SOS Revolution Limit to set the allowed deviation from the position at the beginning of the monitoring. Exceeding the allowed deviation from the starting point activates the STO(+SBC) function as a fault response.

NOTICE

The deviation that is set by SOS Revolution Limit applies to both the directions from the point at the beginning of the monitoring. It is possible that the shaft rotates to one direction almost the maximum deviation and then to the other direction almost double the allowed deviation without violating the monitoring.

During parameterization, the compatibility of the value of SOS Revolution Limit is checked against the pulses per revolution (Encoder/Proximity Sensor Number of Pulses) of the encoder. Setting SOS Revolution Limit below the capability of the encoder is prevented. Example: With a Encoder/Proximity Sensor Number of Pulses value of 10, it is not possible to set SOS Revolution Limit below 0.1 revolutions.

The monitoring is based on the pulses reported by the encoder. With few pulses per revolution, the behavior may not be as expected. Example: When Encoder/Proximity Sensor Number of Pulses has the value 1, and SOS Revolution Limit has the value 1.00, the violation of SOS monitoring is detected when the first pulse is counted. Depending on the actual position of the shaft and the encoder, this can occur with almost no rotation or slightly before the first full revolution.

6.2.4.6 The SS2 and SOS Signals

It is possible that the Active and Reached signals that are mentioned in this chapter are not always available in all interfaces.

NOTICE

The availability of the signals over safe fieldbus depends on the used fieldbus protocol. Refer to chapter Safe fieldbuses for more information.

Table 33: The SS2 and SOS Signals

Signal	Activation and deactivation of the signal	Description
SS2 Active	<p>Activation:</p> <ul style="list-style-type: none"> SS2 is requested and starts execution. <p>Deactivation (manual acknowledgment):</p> <ul style="list-style-type: none"> Acknowledgment signal received after SS2 is not requested. <p>Deactivation (automatic acknowledgment):</p> <ul style="list-style-type: none"> SS2 request ends. <p>Deactivation (SS2 violation situations):</p> <ul style="list-style-type: none"> Reset signal received after SS2 had detected a violation and SS2 has been acknowledged (implicitly or explicitly). 	The signal indicates if SS2 function is being executed.
SS2 Reached	<p>Only activated when SS2 has not detected any violations.</p> <p>Activation:</p> <ul style="list-style-type: none"> Time SS2 t1 elapses (only time monitoring used). OR Speed is below zero speed for time SS2 td2 (zero speed monitoring used). <p>Deactivation (manual acknowledgment):</p> <ul style="list-style-type: none"> SS2 is acknowledged after being reached successfully. <p>Deactivation (automatic acknowledgment):</p> <ul style="list-style-type: none"> SS2 was reached successfully and SS2 request ends. <p>Deactivation (violation or fault):</p> <ul style="list-style-type: none"> A violation or fault occurs during the reached state of SS2. <p>Deactivation (higher priority function is requested)</p> <ul style="list-style-type: none"> STO or SS1 or SQS is requested. 	The signal indicates if SS2 function has been reached successfully.
SOS Reached	<p>Activation:</p> <ul style="list-style-type: none"> SS2 Reached is activated. <p>Deactivation:</p> <ul style="list-style-type: none"> SS2 Reached is deactivated. OR SOS detects a violation. 	The signal indicates if SOS function is being executed.

e30bi344.10

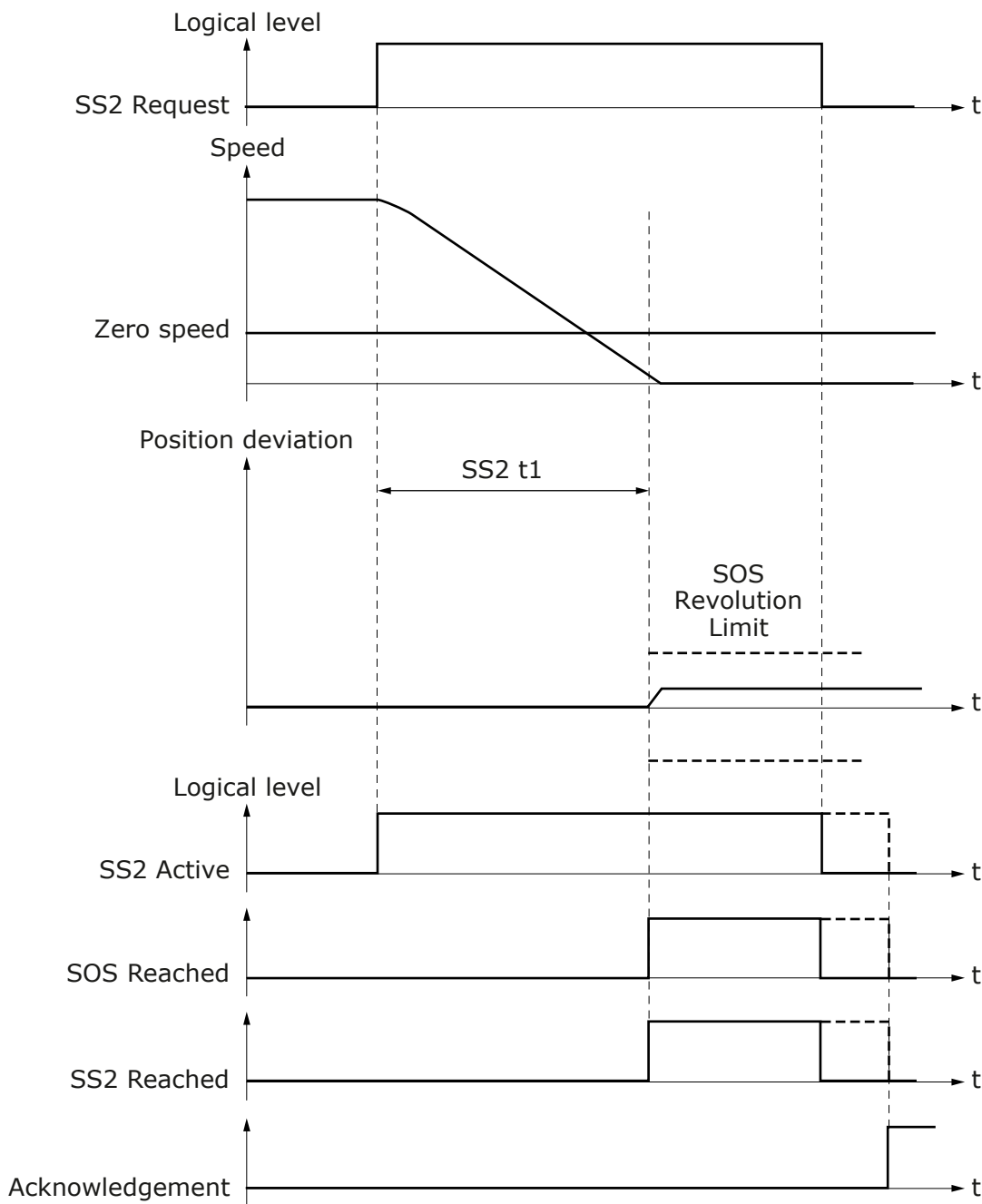
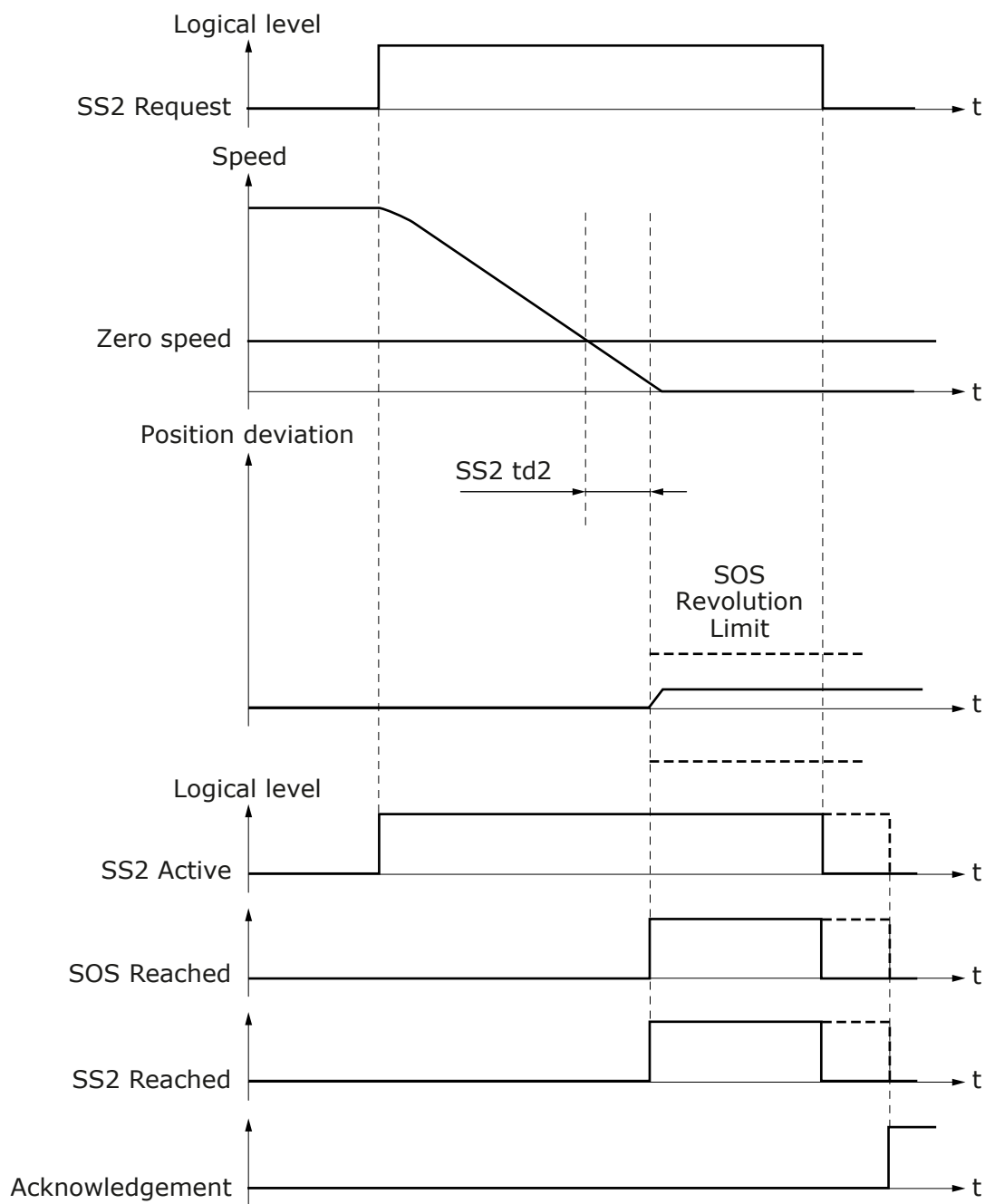
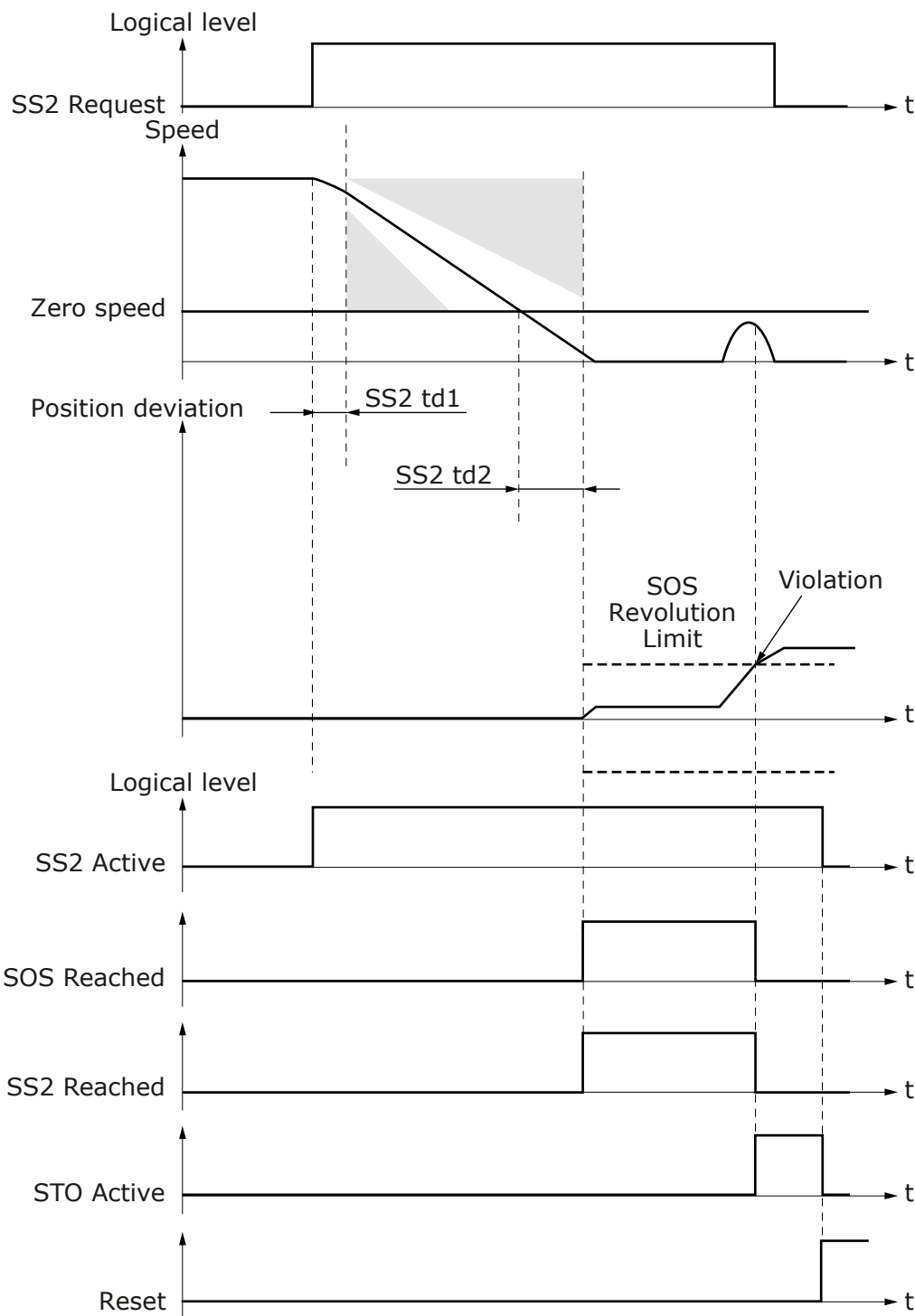

Illustration 44: The SS2 and SOS Signals in Time Monitoring Mode



e30bi345.10

Illustration 45: The SS2 and SOS Signals in Zero Speed Monitoring Mode



e30bi346.10

Illustration 46: The SS2 and SOS Signals in a SOS Violation Case

6.2.5 SQS - Safe Quick Stop

6.2.5.1 Introduction to the SQS Function

The SQS function has 3 modes: SQS-STO, SQS-SS1, and SQS-SS2. The behavior of these modes is the same as the corresponding independent function.

Ramps for SQS-SS1 and SQS-SS2 are set independently of other ramp definitions. For the STO(+SBC) function and the SOS function, the parameters of the individual functions are also used if they are activated as part of the SQS function.

The Safe Quick Stop (SQS) safety function becomes active as the violation response for these safety functions: SLS, SSR, SMS.

The parameters of the SQS safety function are described in [8.7 SQS Parameters](#).

6.2.5.2 The SQS Modes

When the SQS function is set to the SQS-STO mode, the normal STO(+SBC) parameterization is used to execute the STO(+SBC) function when the SQS function is requested. See [6.2.2.1 Introduction to the STO and SBC Functions](#).

When the SQS function is set to the SQS-SS1 or the SQS-SS2 mode, the SQS parameters are used the same way as the corresponding SS1 or SS2 parameters. The SS1 or SS2 parameters are not used. The behavior of the SQS-SS1 and the SQS-SS2 mode is the same as that of the independent SS1 and SS2 functions. See [6.2.3.1 Introduction to the SS1 Function](#) and [6.2.4.1 Introduction to the SS2 and SOS Functions](#).

N O T I C E

For SOS after SQS-SS2, the parameterization of normal SOS is used.

N O T I C E

The SQS-SS1 and the SQS-SS2 functions are higher in priority than the independent SS1 and SS2 functions. See chapter [6.2.1 Introduction to the Safe Stopping Functions](#).

The SQS function does not use the shared ramp definitions. Instead the SQS function has its own ramp definition parameters. The ramps are parameterized, calculated, and monitored the same way as other ramps. See [6.1.7 Ramps](#).

6.2.5.3 The SQS Signals

It is possible that the Active and Reached signals that are mentioned in this chapter are not always available in all interfaces.

The SS1 and SS2 signals do not become active when the SQS-SS1 or the SQS-SS2 mode is active. However, the SOS, the STO, and the SBC signals become active when the corresponding SQS mode is active.

N O T I C E

The availability of the signals over safe fieldbus depends on the fieldbus protocol that you use. Refer to chapter Safe fieldbuses for more information. If the SQS function is not available in the fieldbus protocol, the fieldbus shows the signals of the SS1 or the SS2 function instead.

Table 34: The SQS Signals

Signal	Activation and deactivation of the signal	Description
SQS Active	Activation: <ul style="list-style-type: none"> • SQS is requested and starts execution. OR • A safe monitoring function detects a violation and activates SQS. Deactivation (manual acknowledgment): <ul style="list-style-type: none"> • Acknowledgment signal received after SQS is not requested. OR • The violated safe monitoring function is reset. Deactivation (automatic acknowledgment): <ul style="list-style-type: none"> • SQS request ends. OR • The violated function is reset. Deactivation (SQS violation situations): <ul style="list-style-type: none"> • Reset signal received after SQS had detected a violation and SQS has been acknowledged (implicitly or explicitly). 	The signal indicates if SQS function is being executed.
SQS Reached	Only activated when SQS has not detected any violations. Activation: <ul style="list-style-type: none"> • STO(+SBC) is reached (SQS_STO) OR • Time SQS t1 elapses (SQS-SS1 & SQS-SS2: only time monitoring used). OR • Speed is below zero speed for time SQS td1 (SQS-SS1 & SQS-SS2: zero speed monitoring used). 	The signal indicates if SQS function has been reached successfully.

Signal	Activation and deactivation of the signal	Description
	<p>Deactivation (manual acknowledgment):</p> <ul style="list-style-type: none"> • SQS is acknowledged after being reached successfully. (Normal request) OR • The violated function is reset. (Violation response) <p>Deactivation (automatic acknowledgment):</p> <ul style="list-style-type: none"> • SQS was reached successfully and SQS request ends. (Normal request) OR • The violated function is reset. (Violation response) <p>Deactivation (violation or fault):</p> <ul style="list-style-type: none"> • A violation or fault occurs during the reached state of SQS-SS2. <p>Deactivation (higher priority function is requested)</p> <ul style="list-style-type: none"> • STO is requested. 	
<p>SOS Reached</p>	<p>Activation:</p> <ul style="list-style-type: none"> • SQS Reached is activated. <p>Deactivation:</p> <ul style="list-style-type: none"> • SQS Reached is deactivated. OR • SOS detects a violation. 	<p>The signal indicates if SOS function is being executed.</p>

The SQS signals behave the same way as the corresponding signals in the SS1 and the SS2 functions. For example, SQS Active behaves the same way as SS1 Active when the SQS mode is set to SS1. For the behavior in other cases, refer to the figures in [6.2.3.1 Introduction to the SS1 Function](#) and [6.2.4.1 Introduction to the SS2 and SOS Functions](#).

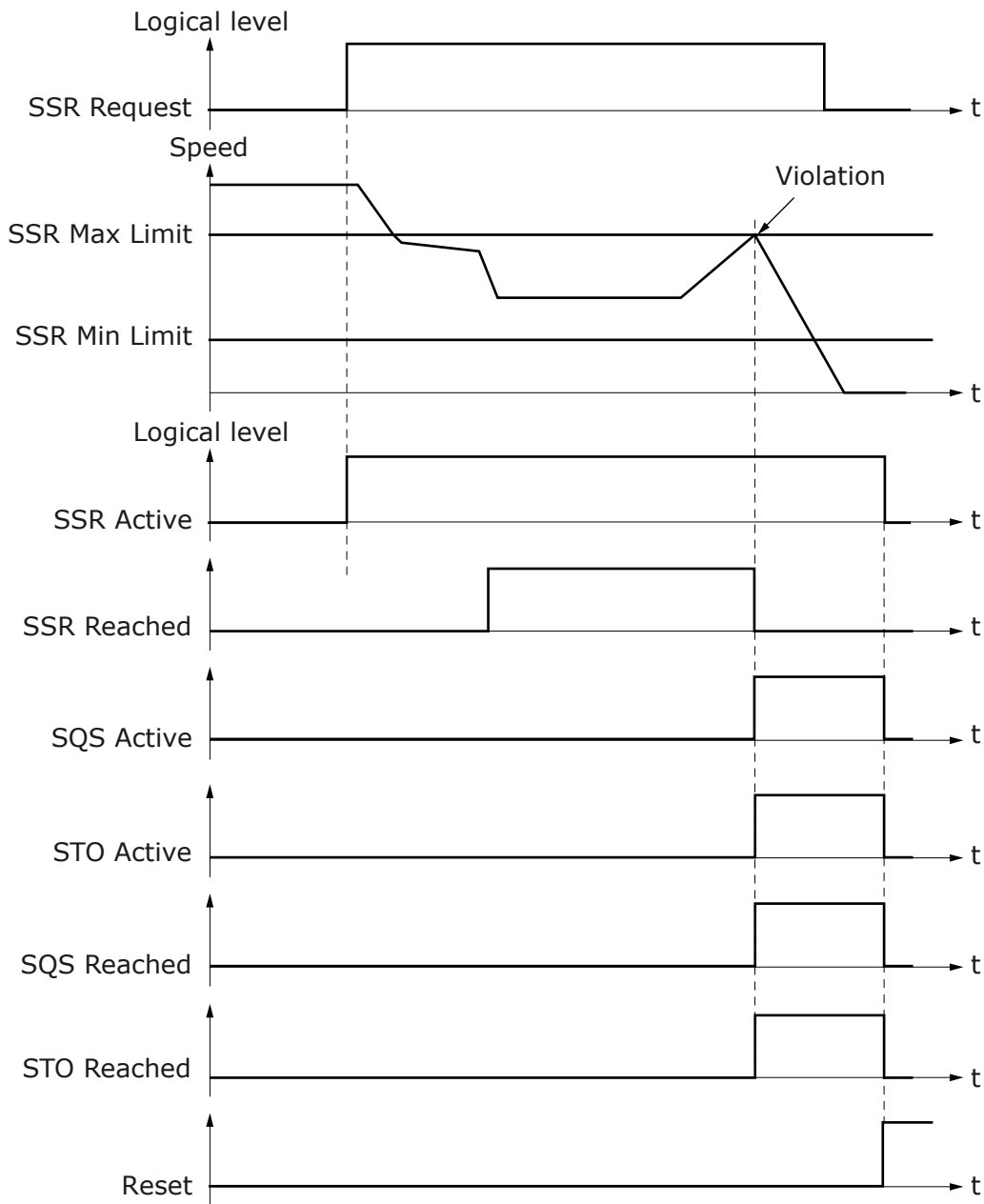

e30bi341.10

Illustration 47: The SQS-STO Function as a Violation Response to an SSR Speed Violation. The SBC Function is not Used.

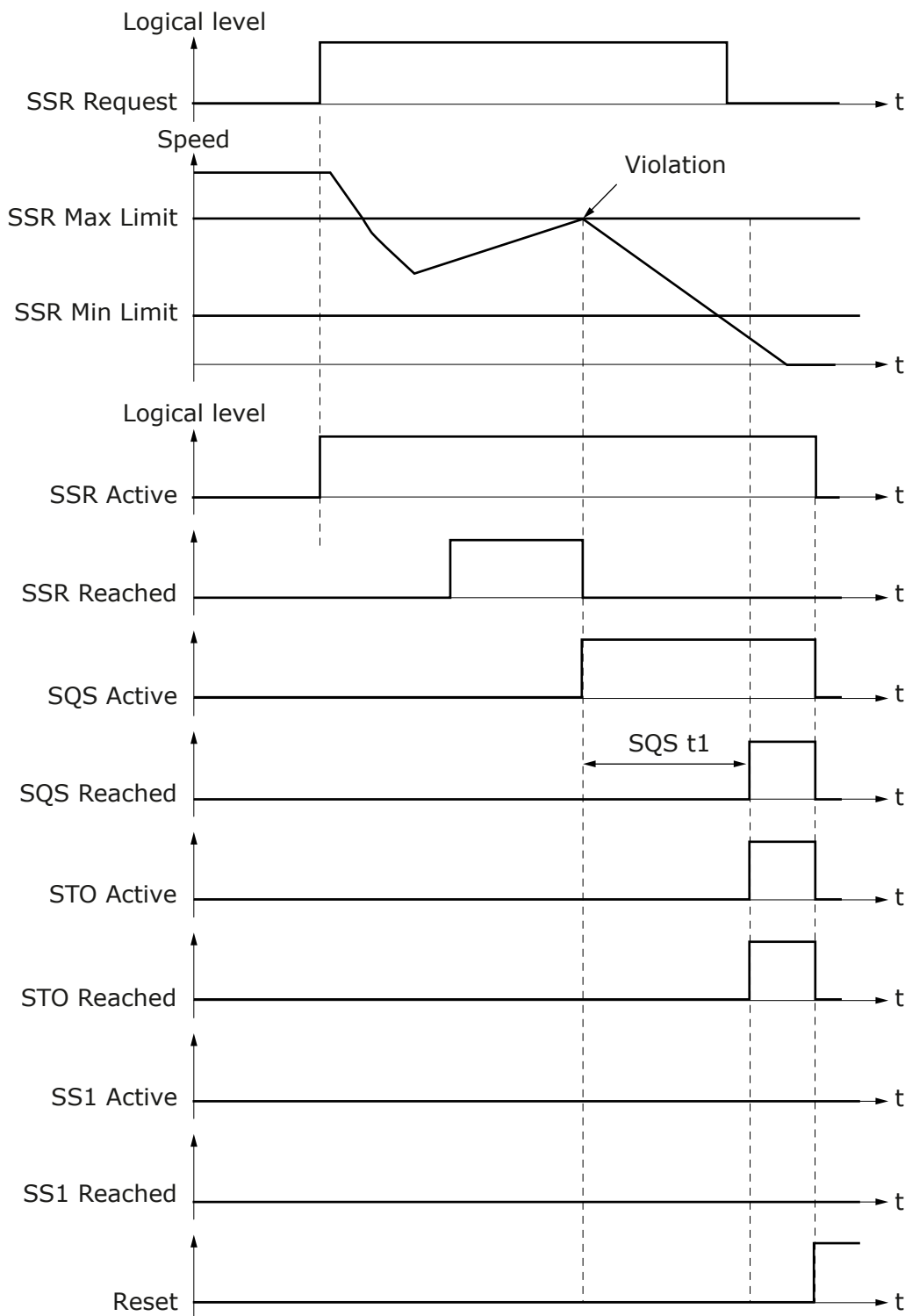

e30bi342.10

Illustration 48: The SQS-SS1 Function as a Violation Response to an SSR Speed Violation. The SQS Function Uses Time Monitoring Mode. The SS1 Signals are not Used with the SQS-SS1 Mode.

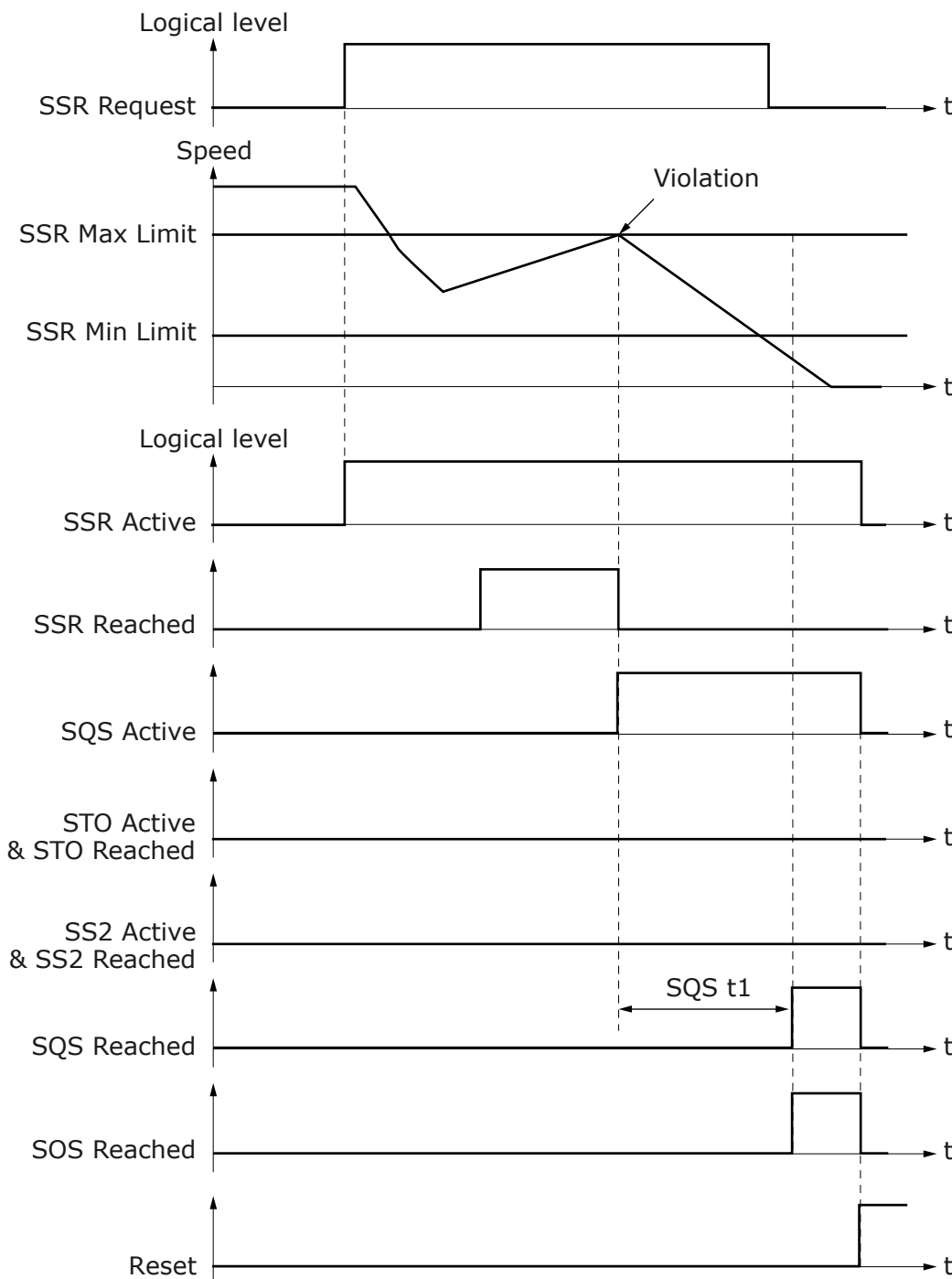

e30bi343.10

Illustration 49: The SQS-SS2 Function as a Violation Response to an SSR Speed Violation. The SQS Function Uses Time Monitoring Mode. The SS2 Signals are not Used with the SQS-SS2 Mode.

6.3 Safe Monitoring Functions

6.3.1 Introduction to the Safe Monitoring Functions

The safe monitoring functions are used to monitor the speed, the position, or the acceleration of the motor. Most safe monitoring functions do not take into account the direction of the movement, but only the absolute value.

The safe monitoring functions that do not take into account the direction of movement

- SLS
- SSM
- SSR

The safe monitoring functions that take into account the direction of movement

- SMS

You can use all safe monitoring functions at the same time. All active safe monitoring functions monitor the limits that were set for them. A violation of any of these limits causes the SQS function to be requested as a violation response.

NOTICE

The limit that a safe monitoring function monitors (for example speed, position, or acceleration) is used as a trigger for the SQS function. Depending on the parameterization of the SQS function and the system configuration, there can be a delay for the actions that control the movement of the motor.

The safe monitoring functions, except for SSM, do not monitor during violations, faults in the Advanced safety option board, or when the STO or the SOS function is active.

6.3.2 SLS - Safe Limited Speed

6.3.2.1 Introduction to the SLS Function

The Safe Limited Speed (SLS) safety function monitors that the motor speed does not exceed the parameterized speed limit. The SLS function provides 3 parameterizable speed limits that you can switch during operation: SLS 1 Limit, SLS 2 Limit, and SLS 3 Limit. Deceleration during the initial activation can be monitored with a deceleration ramp. The SLS function can be configured with or without ramp monitoring.

The violation response is the SQS function.

The parameters of the SLS safety function are described in [8.8 SLS Parameters](#).

6.3.2.2 Time Monitoring

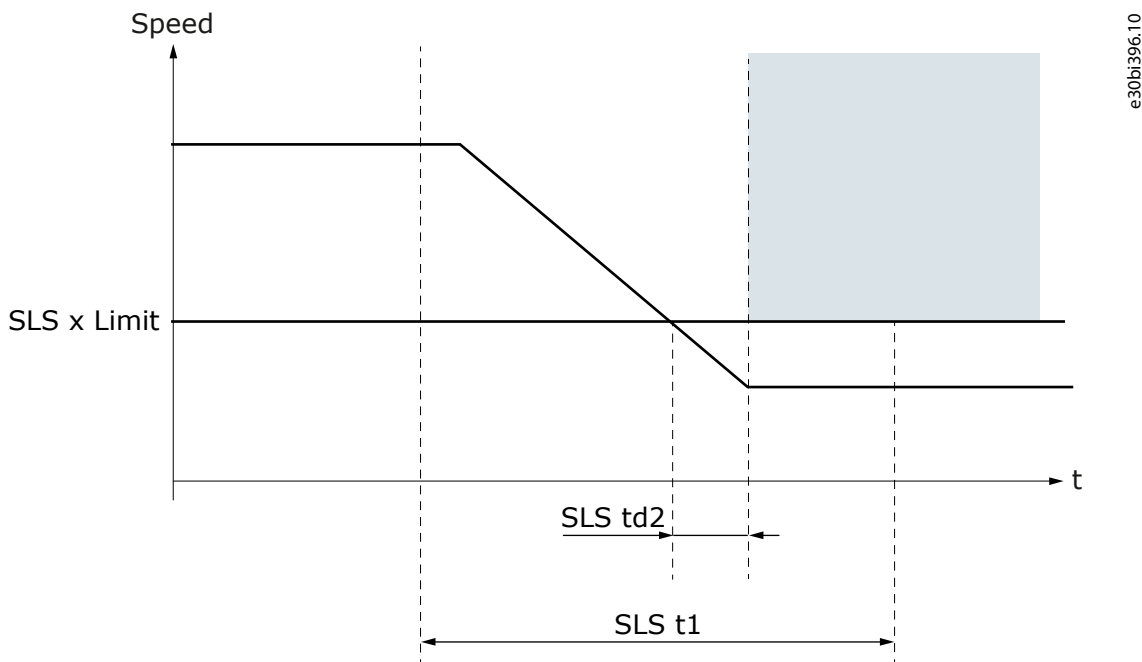

Illustration 50: The SLS Function in the Time Monitoring Mode

The time monitoring mode is always used when SLS is active. In the time monitoring, the SLS function must be reached before the time that is set with SLS t1 elapses. The monitoring of the speed limit starts after the function is reached.

If the function is not reached in the set time, or the speed limit is exceeded after the function is reached, the SQS function becomes active as a violation response.

6.3.2.3 Ramp Monitoring

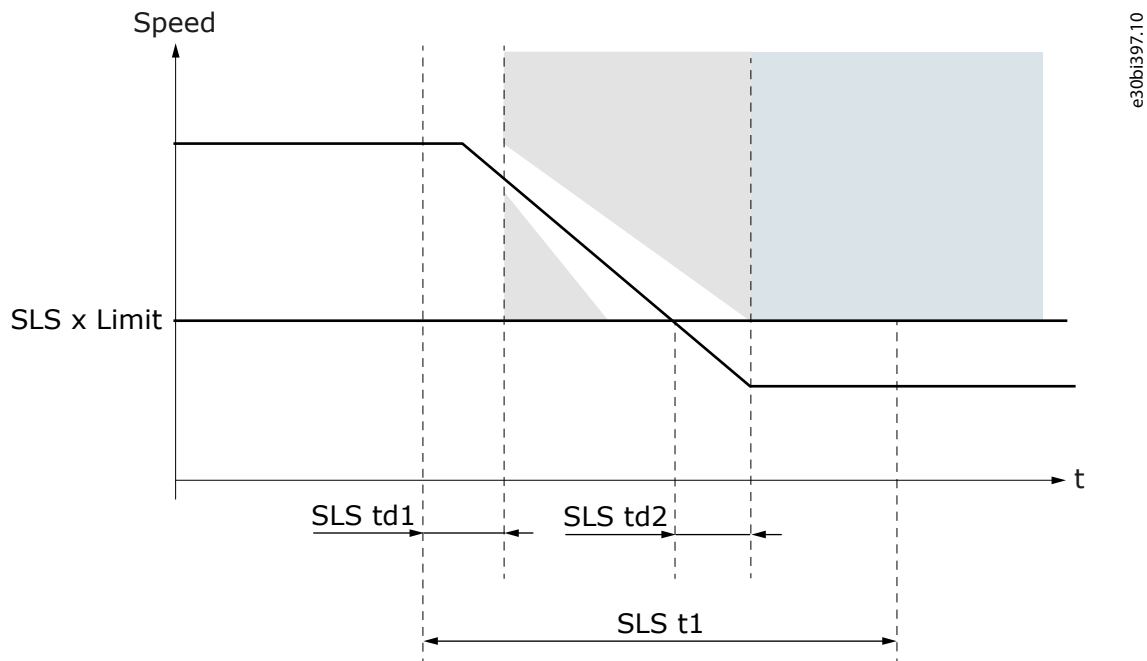

Illustration 51: The SLS Function in the Ramp Monitoring Mode

When ramp monitoring is used, time monitoring is also used. The ramp monitoring monitors that the initial speed change after the function is requested obeys the set deceleration ramp. Select the monitored ramp with parameter SLS Ramp Monitoring. It is possible to monitor the minimum ramp, the maximum ramp, or both these ramps.

The ramp monitoring starts after the time that is set in SLS td1 elapses. The time delay of SLS td1 starts when the SLS function becomes active. The ramp monitoring ends when the SLS function is reached. If the speed does not obey the parameterized ramp during the monitoring, the SQS function becomes active as a violation response. The ramp monitoring does not continue below the requested speed limit.

NOTICE

The ramp monitoring is not executed when the speed limit changes. The monitoring for the previous speed limit stays active during the change.

NOTICE

After a new SLS request, if a speed limit change occurs before the initial speed limit is reached, the new request is handled as a new initial request. The timers of the parameters SLS t1 and SLS td2 restart, and ramp monitoring is executed, if it was used.

6.3.2.4 The Speed Limit Selection of the SLS Function

The SLS function has 3 different speed limits: SLS 1 Limit, SLS 2 Limit, and SLS 3 Limit. When a speed limit is requested from both a digital input and via fieldbus, the monitored speed limit is selected by the priority of the speed limits. The priority of the speed limits is independent of the actual value of the speed limits.

The priority of the speed limits (from the highest to the lowest)

1. SLS 1 Limit
2. SLS 2 Limit
3. SLS 3 Limit
4. No SLS requested

NOTICE

It is possible to parameterize a higher priority speed limit to allow higher speed than a lower priority speed limit, but it is not recommended.

When the speed limit is changed, the monitoring behavior depends on whether the speed value of the new speed limit is higher or lower than that of the current speed limit. When changing to a speed limit with a higher speed value, the monitoring of the new limit starts immediately, and the monitoring for the old speed limit ends.

When changing to a speed limit with a lower speed value, the monitoring of the old speed limit stays active for the time that is set with SLS t1. After the set time, the monitoring of the old speed limit ends and the monitoring of the new speed limit starts.

NOTICE

After a new SLS request, if a speed limit change occurs before the initial speed limit is reached, the new request is handled as a new initial request. The timers of the parameters SLS t1 and SLS td2 restart, and ramp monitoring is executed, if it was used.

When two digital inputs are used to select the speed limit, parameter SLS td3 is used. SLS td3 determines the transition time that is permitted for the two inputs to reach the selected value. The first change from the executed selection value (SLS 1 Limit, SLS 2 Limit, SLS 3 Limit, or No SLS requested) starts the timer of the parameter SLS td3. After the time set with SLS td3, the inputs are examined and based on the results, a new speed limit is selected.

NOTICE

If the change in the input state was caused by an accident and the request signals return to the currently executed selection, the monitoring of that limit is not interrupted.

Table 35: Selecting the SLS Limit with 1 Digital Input

SLS Input 1	SLS LIMIT
0	SLS 1 Limit
1	No SLS limit requested

Table 36: Selecting the SLS Limit with 2 Digital Inputs

SLS Input		SLS LIMIT
1	2	
0	0	SLS 1 Limit
0	1	SLS 2 Limit
1	0	SLS 3 Limit
1	1	No SLS limit requested

When you request the SLS function over a safe fieldbus, see [7.1.1 Introduction to PROFIsafe](#).

6.3.2.5 The SLS Signals

It is possible that the Active and Reached signals that are mentioned in this chapter are not always available in all interfaces.

NOTICE

The availability of the signals over safe fieldbus depends on the used fieldbus protocol. Refer to chapter Safe fieldbuses for more information.

Table 37: The SLS Signals

Signal	Activation and deactivation of the signal	Description
SLS 1 Active SLS 2 Active SLS 3 Active	Activation: <ul style="list-style-type: none"> SLS is requested and starts to execute. Deactivation (manual acknowledgment):	The signal indicates if SLS function is being executed.

Signal	Activation and deactivation of the signal	Description
	<ul style="list-style-type: none"> • Acknowledgment signal received and SLS is not requested. OR • Another SLS limit is requested and taken into use. Deactivation (automatic acknowledgment): <ul style="list-style-type: none"> • SLS request ends. OR • Another SLS limit is requested and taken into use. Deactivation (SLS violation situations): <ul style="list-style-type: none"> • Reset signal received after SLS had detected a violation and SLS has been acknowledged (implicitly or explicitly). 	
SLS 1 Reached SLS 2 Reached SLS 3 Reached	Only activated when SLS has not detected any violations. Activation: <ul style="list-style-type: none"> • Speed is below SLS speed limit. Deactivation (manual acknowledgment): <ul style="list-style-type: none"> • SLS is acknowledged after being reached successfully. OR • Another SLS limit is activated and reached. Deactivation (automatic acknowledgment): <ul style="list-style-type: none"> • SLS was reached successfully and SLS request ends. OR • Another SLS limit is activated and reached. Deactivation (STO state): <ul style="list-style-type: none"> • STO is activated. 	The signal indicates if SLS function has been reached successfully.

e30bi347.10

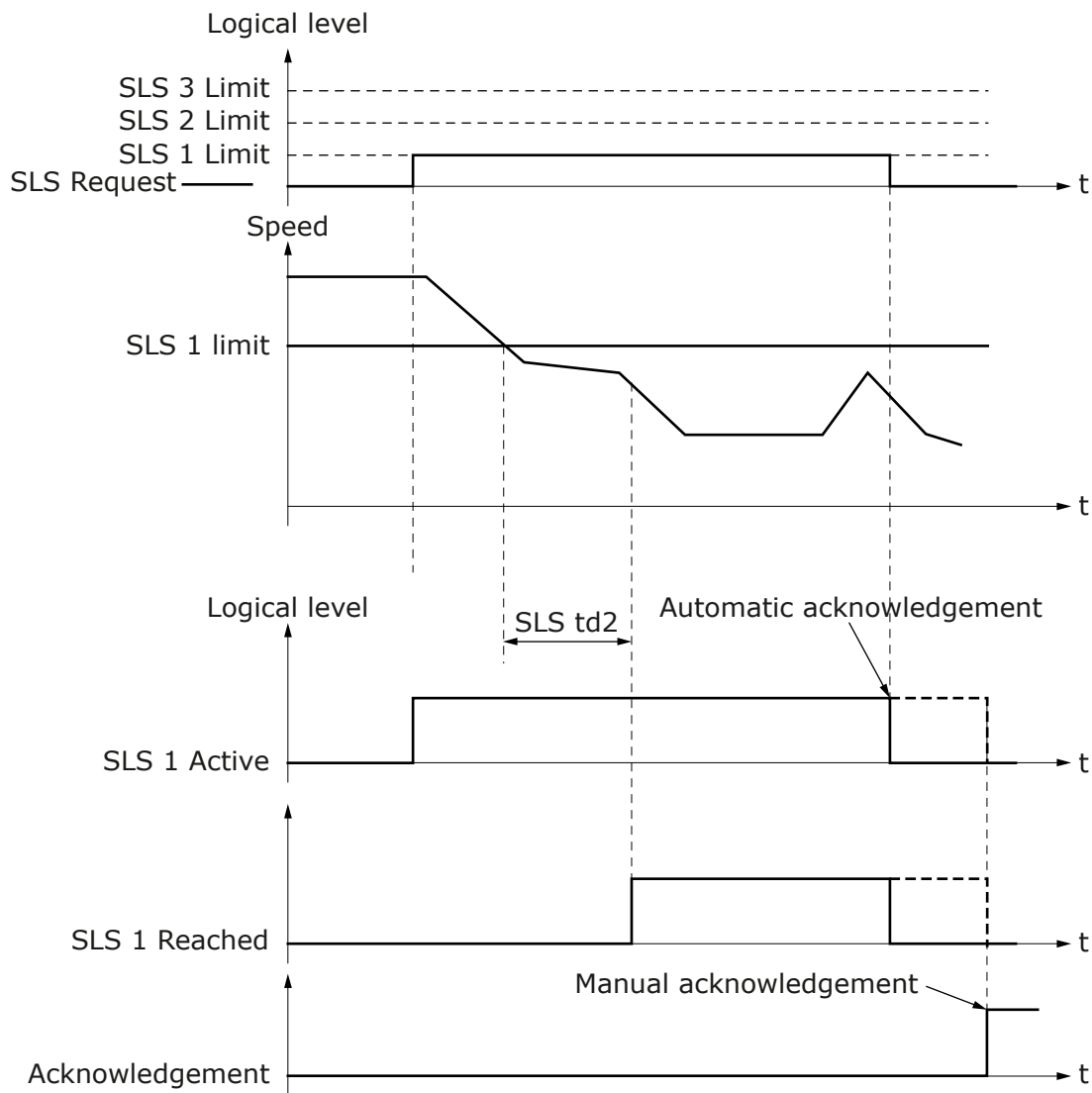
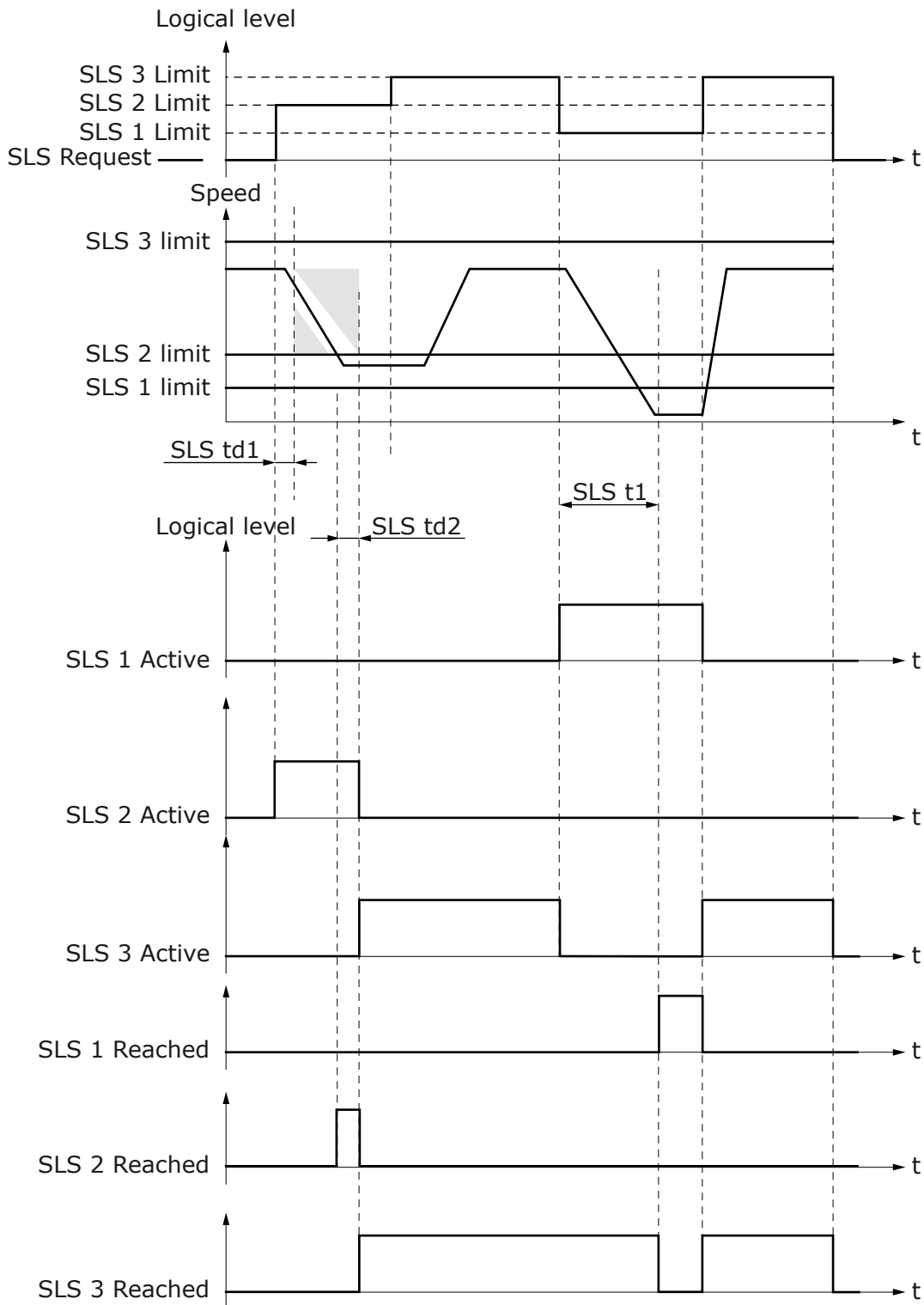

Illustration 52: The SLS 1 is Requested and Deactivated. Time Monitoring Only.



e30bi348.10

Illustration 53: Changing the SLS Limits. Ramp Monitoring is Active Only at the Initial Activation of the SLS Function.

e30bi349,10

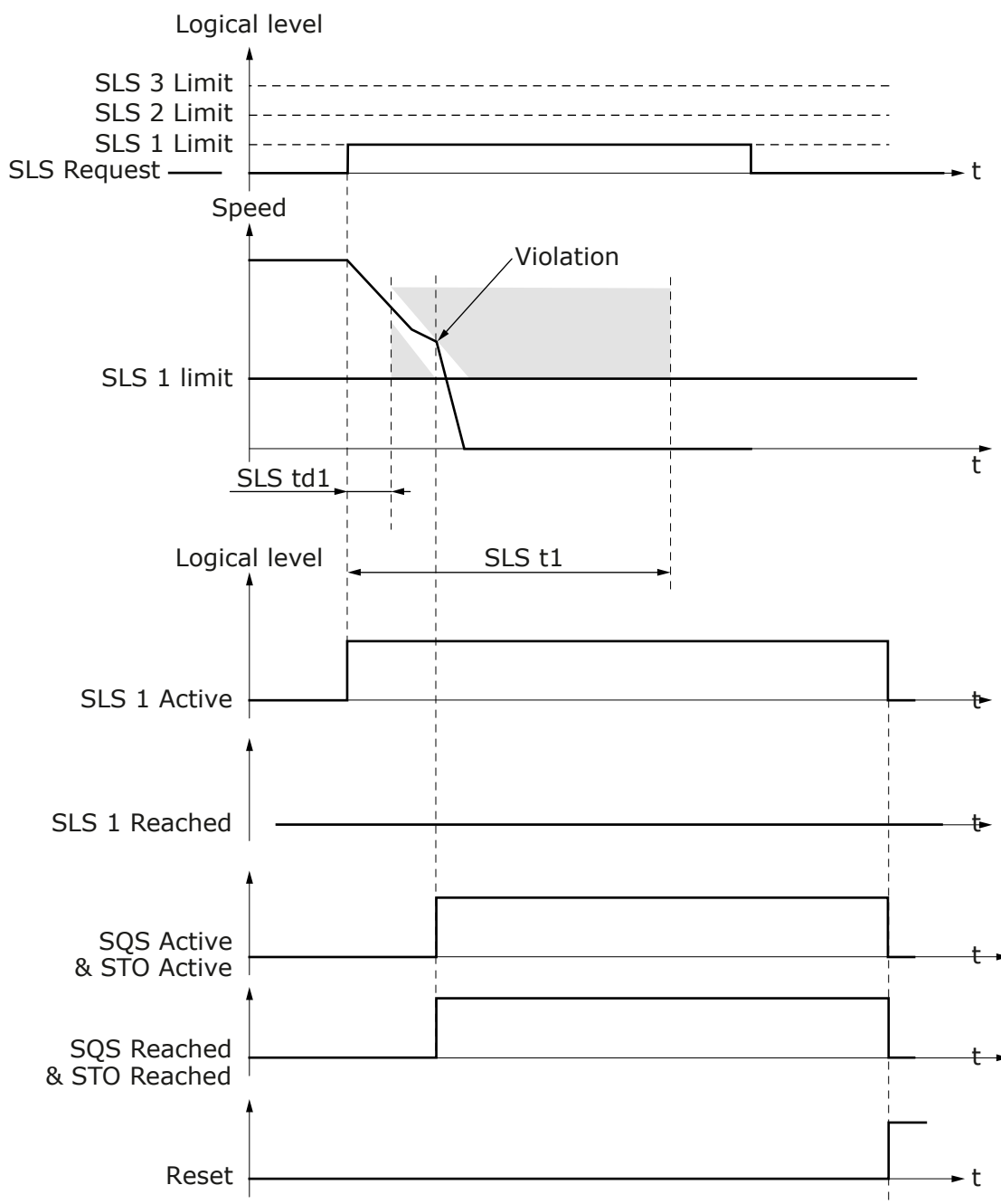

Illustration 54: An SLS Ramp Violation. The SQS-STO Function as a Violation Response.

6.3.3 SMS - Safe Maximum Speed

6.3.3.1 Introduction to the SMS Function

The Safe Maximum Speed (SMS) safety function monitors that the motor speed does not exceed the parameterized speed limit. The limit can be set independently for both the rotation directions of the motor.

The violation response is the SQS function.

The parameters of the SMS safety function are described in [8.9 SMS Parameters](#).

6.3.3.2 The Maximum Speed Monitoring

The maximum speed monitoring starts immediately when the SMS function is requested and becomes active. If the limits are not violated, the function stays in the Reached state.

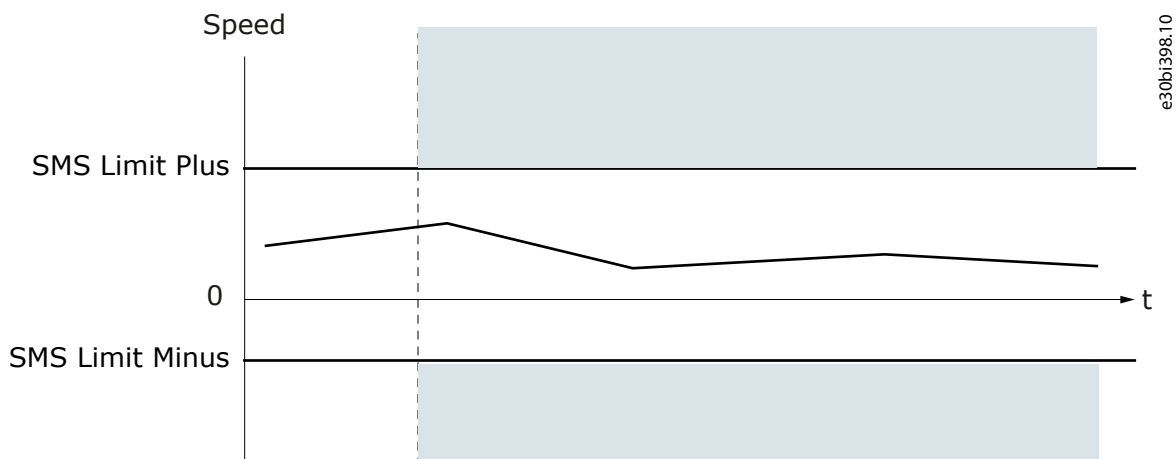

Illustration 55: The Operation of the SMS Function

If a proximity sensor is used to monitor the speed of the motor, it can be necessary to set the limits to the same absolute value, for example, 50 and -50. See chapter [3.6.2 Standard Speed Sensors and Combinations](#).

NOTICE

Setting a limit to zero does not disable the monitoring.

6.3.3.3 The SMS Signals

It is possible that the Active and Reached signals that are mentioned in this chapter are not always available in all interfaces.

NOTICE

The availability of the signals over safe fieldbus depends on the used fieldbus protocol. Refer to chapter Safe fieldbuses for more information.

Table 38: The SMS Signals

Signal	Activation and deactivation of the signal	Description
SMS Active	Activation: <ul style="list-style-type: none"> SMS is requested and starts to execute. Deactivation (manual acknowledgment): <ul style="list-style-type: none"> Acknowledgment signal received and SMS is not requested. Deactivation (automatic acknowledgment): <ul style="list-style-type: none"> SMS request ends. Deactivation (SMS violation situations): <ul style="list-style-type: none"> Reset signal received after SMS had detected a violation and SMS has been acknowledged (implicitly or explicitly). 	The signal indicates if the SMS function is being executed.
SMS Reached	Activation: <ul style="list-style-type: none"> SMS is active and speed is within safe range. Deactivation (manual acknowledgment): <ul style="list-style-type: none"> SMS is acknowledged after being reached successfully. Deactivation (automatic acknowledgment): <ul style="list-style-type: none"> SMS was reached successfully and SMS request ends. Deactivation (STO state): <ul style="list-style-type: none"> STO is activated. 	The signal indicates if the SMS function has been reached successfully.

e30bi350.10

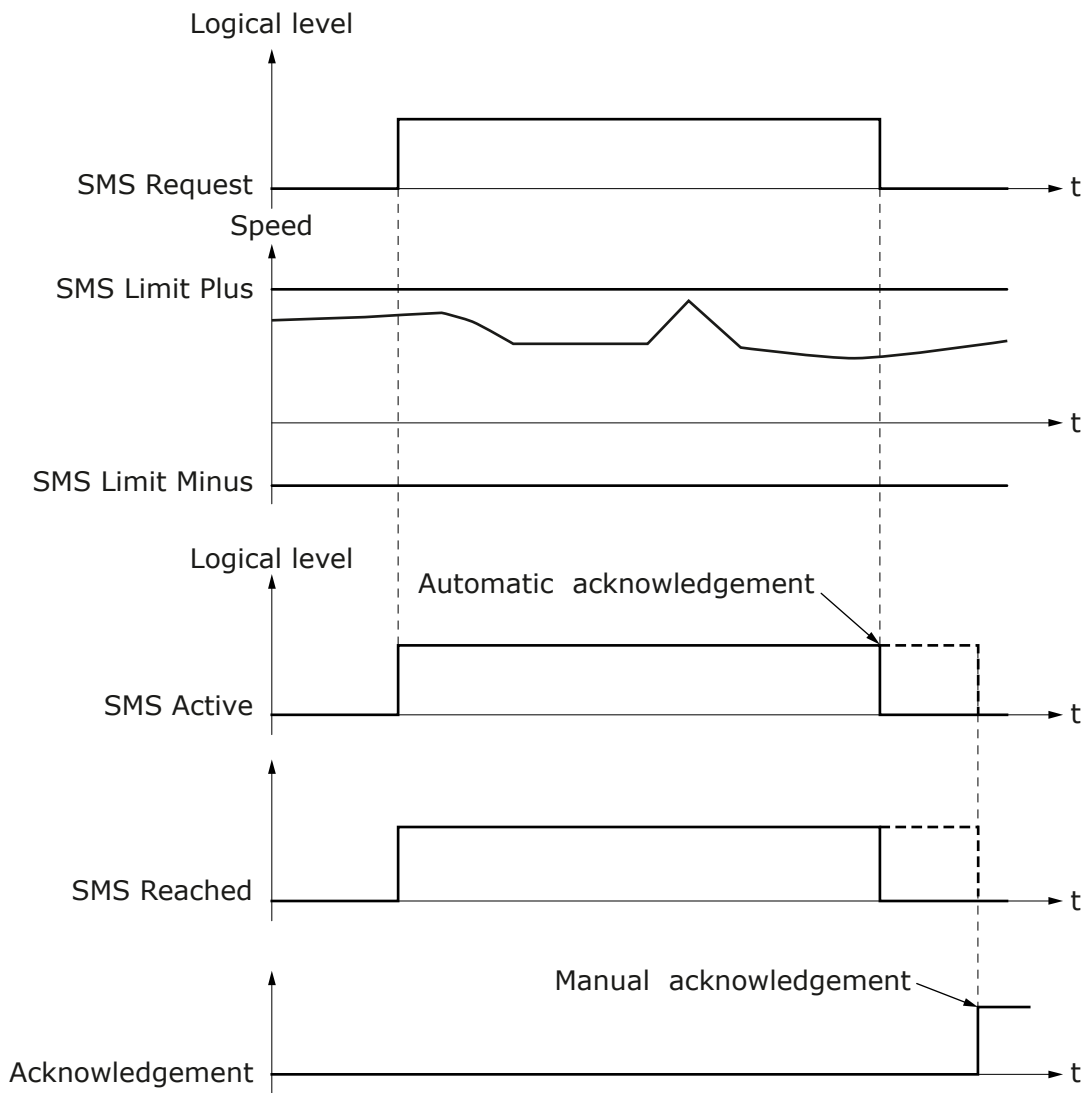
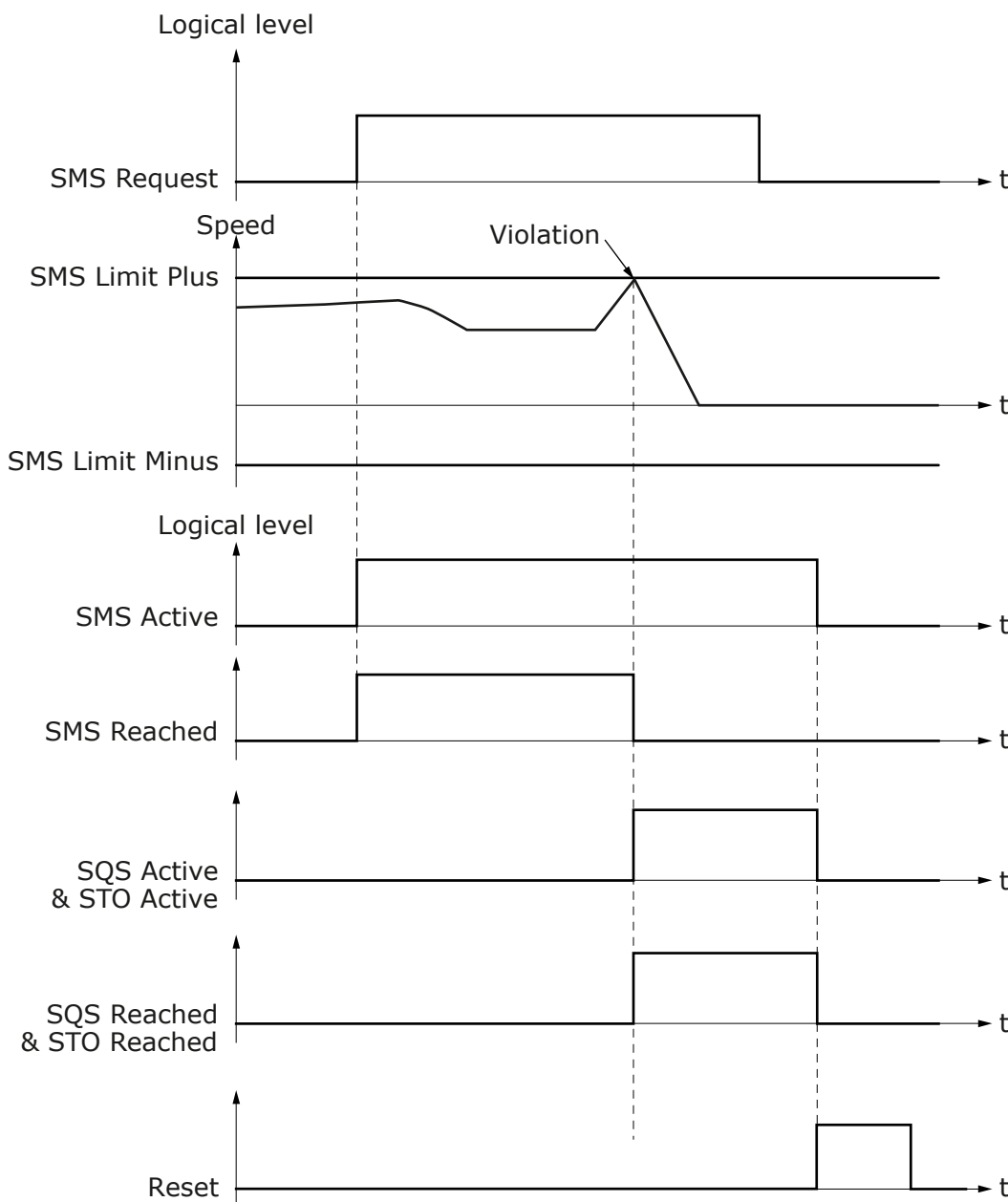

Illustration 56: The Signals of the SMS Function



e30bi351.10

Illustration 57: An SMS Violation. The SQS-STO Function as a Violation Response. SMS: Manual Acknowledgment.

6.3.4 SSR - Safe Speed Range

6.3.4.1 Introduction to the SSR Function

The Safe Speed Range (SSR) safety function monitors that the motor speed stays in parameterized speed range. It is possible to set and monitor a maximum and a minimum motor speed. The SSR function can be configured with or without ramp monitoring.

After the function has been activated, the deceleration or the acceleration to a safe range can be monitored with the ramp monitoring mode.

The violation response is the SQS function.

The parameters of the SSR safety function are described in [8.10 SSR Parameters](#).

6.3.4.2 Time Monitoring

The time monitoring mode is always used when SSR is active. In the time monitoring, the SSR function must be reached before the time that is set with SSR t1 elapses. The monitoring of the speed limit starts after the function is reached.

If the function is not reached in the set time, or the speed limit is exceeded after the function is reached, the SQS function becomes active as a violation response.

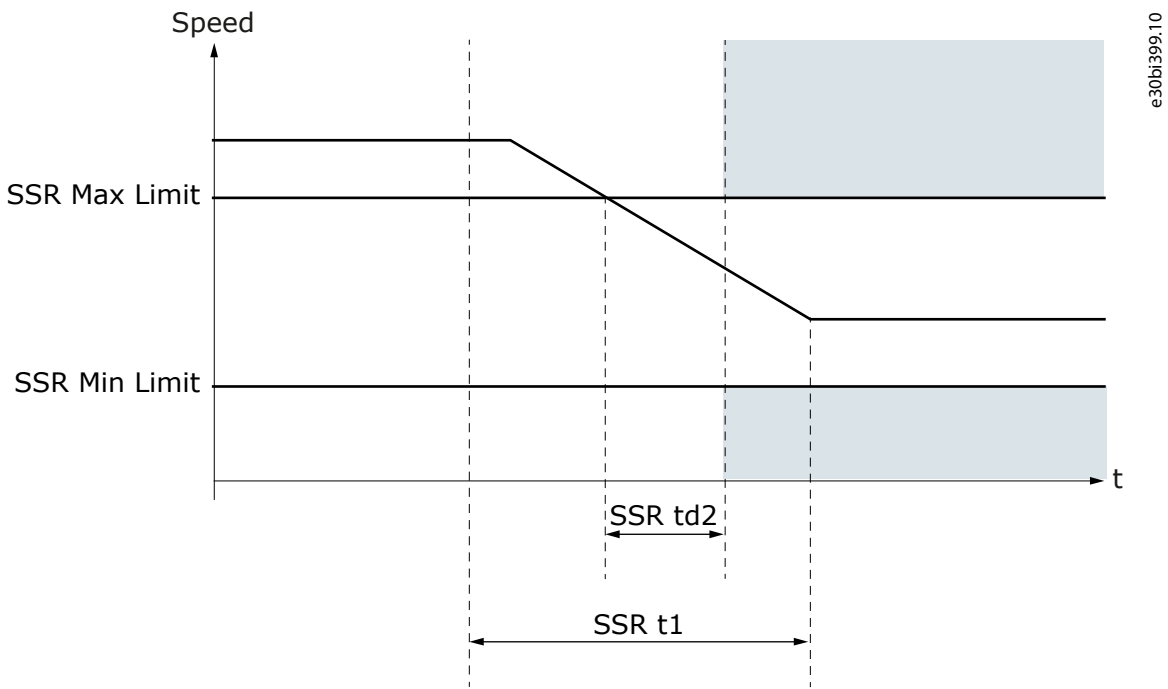

Illustration 58: The SSR Function in the Time Monitoring Mode

NOTICE

When you set the value of SSR Min Limit above zero, you must take into account the situations where the motor is stopped or changes direction. If the speed goes below the SSR Min Limit and the SSR function is monitoring, the SSR function detects a violation. The speed can be below the SSR Min Limit, for example, if the STO function or the SOS function is active. After the STO function or the SOS function is deactivated, the SSR function can start monitoring again after the time set with SSR t1, and detect a violation. It may be necessary to disable the SSR request while the motor is stopped. See [6.4 Combinations of Safety Functions](#).

6.3.4.3 Ramp Monitoring

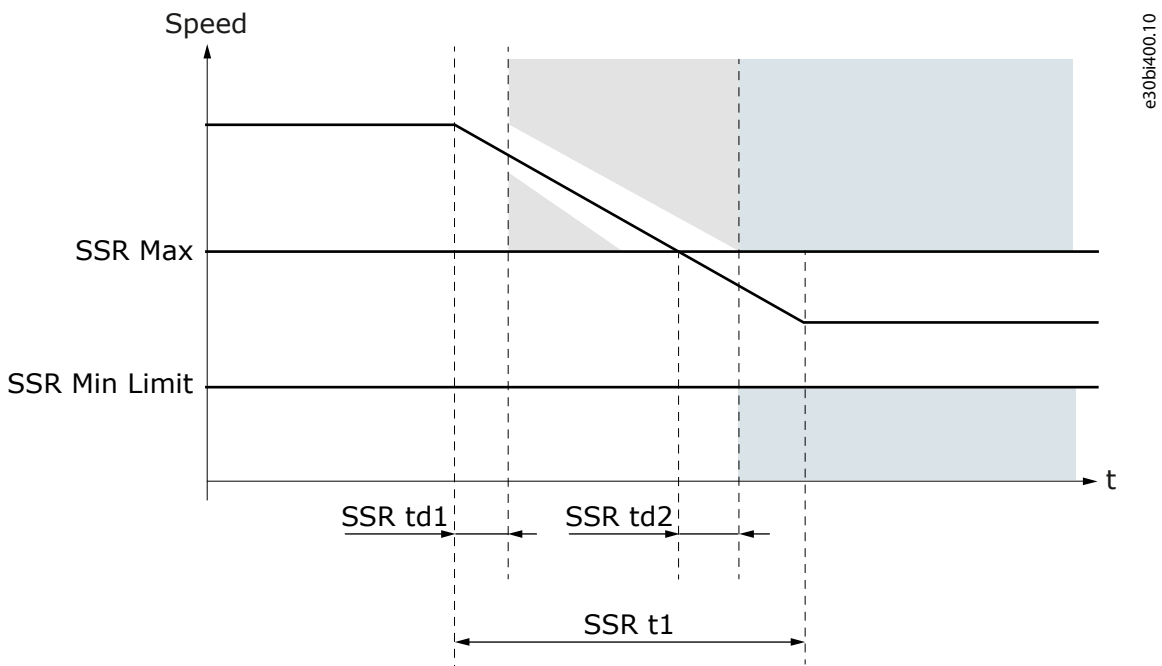

Illustration 59: The SSR Function in the Ramp Monitoring Mode

When ramp monitoring is used, time monitoring is also used. The ramp monitoring monitors that the initial speed change after the function is requested obeys the set deceleration ramp. Select the monitored ramp with parameter SSR Ramp Monitoring. It is possible to monitor the minimum ramp, the maximum ramp, or both these ramps.

The ramp monitoring starts after the time that is set in SSR td1 elapses. The time delay of SSR td1 starts when the SSR function becomes active. The ramp monitoring ends when the SSR function is reached. If the speed does not obey the parameterized ramp during the monitoring, the SQS function becomes active as a violation response. The ramp monitoring does not continue when the speed is in the safe speed range.

NOTICE

The ramp monitoring is used for both the deceleration and the acceleration to a safe range.

The ramp monitoring is always active according to the parameters of the selected ramp. If the selected ramp has both acceleration and deceleration, monitoring for both is active. On the opposite side to the actual executed ramp monitoring, the ramp monitoring is limited to the monitored limit. This means that during ramp monitoring it is possible for the speed to cross the safe range and cause a ramp violation on the other limit.

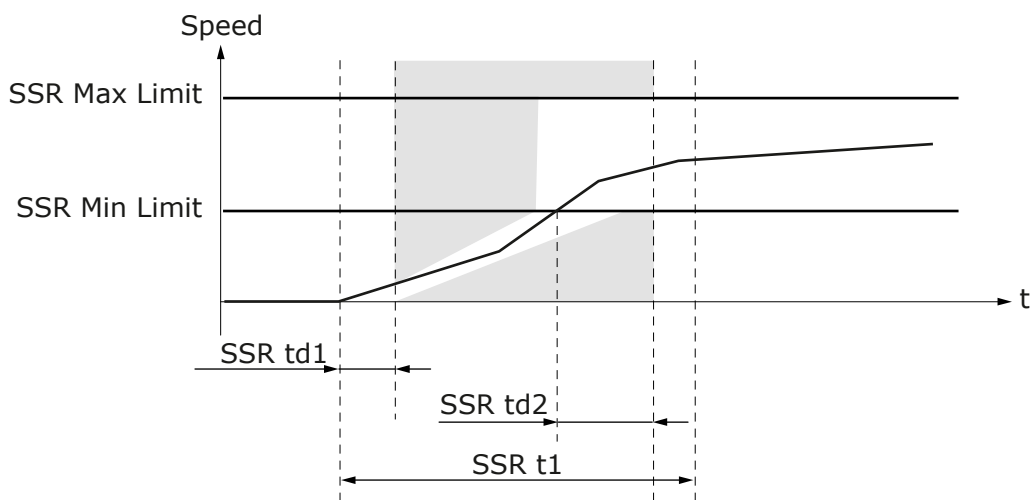

e30b1401.10

Illustration 60: Ramp Monitoring During Acceleration to the Safe Range

6.3.4.4 The SSR Signals

It is possible that the Active and Reached signals that are mentioned in this chapter are not always available in all interfaces.

NOTICE

The availability of the signals over safe fieldbus depends on the used fieldbus protocol. Refer to chapter Safe fieldbuses for more information.

Table 39: The SSR Signals

Signal	Activation and deactivation of the signal	Description
SSR Active	Activation: <ul style="list-style-type: none"> SSR is requested and starts execution. Deactivation (manual acknowledgment): <ul style="list-style-type: none"> Acknowledgment signal received and SSR is not requested. Deactivation (automatic acknowledgment): <ul style="list-style-type: none"> SSR request ends. Deactivation (SSR violation situations):	The signal indicates if the SSR function is being executed.

Signal	Activation and deactivation of the signal	Description
	<ul style="list-style-type: none"> Reset signal received after SSR had detected a violation and SSR has been acknowledged (implicitly or explicitly). 	
SSR Reached	<p>Only activated when SSR has not detected any violations.</p> <p>Activation:</p> <ul style="list-style-type: none"> Speed is between selected SSR td2 time limits. <p>Deactivation (manual acknowledgment):</p> <ul style="list-style-type: none"> SSR is acknowledged after being reached successfully. <p>Deactivation (automatic acknowledgment):</p> <ul style="list-style-type: none"> SSR was reached successfully and SSR request ends. <p>Deactivation (STO state):</p> <ul style="list-style-type: none"> STO is activated. 	The signal indicates if the SSR function has been reached successfully.

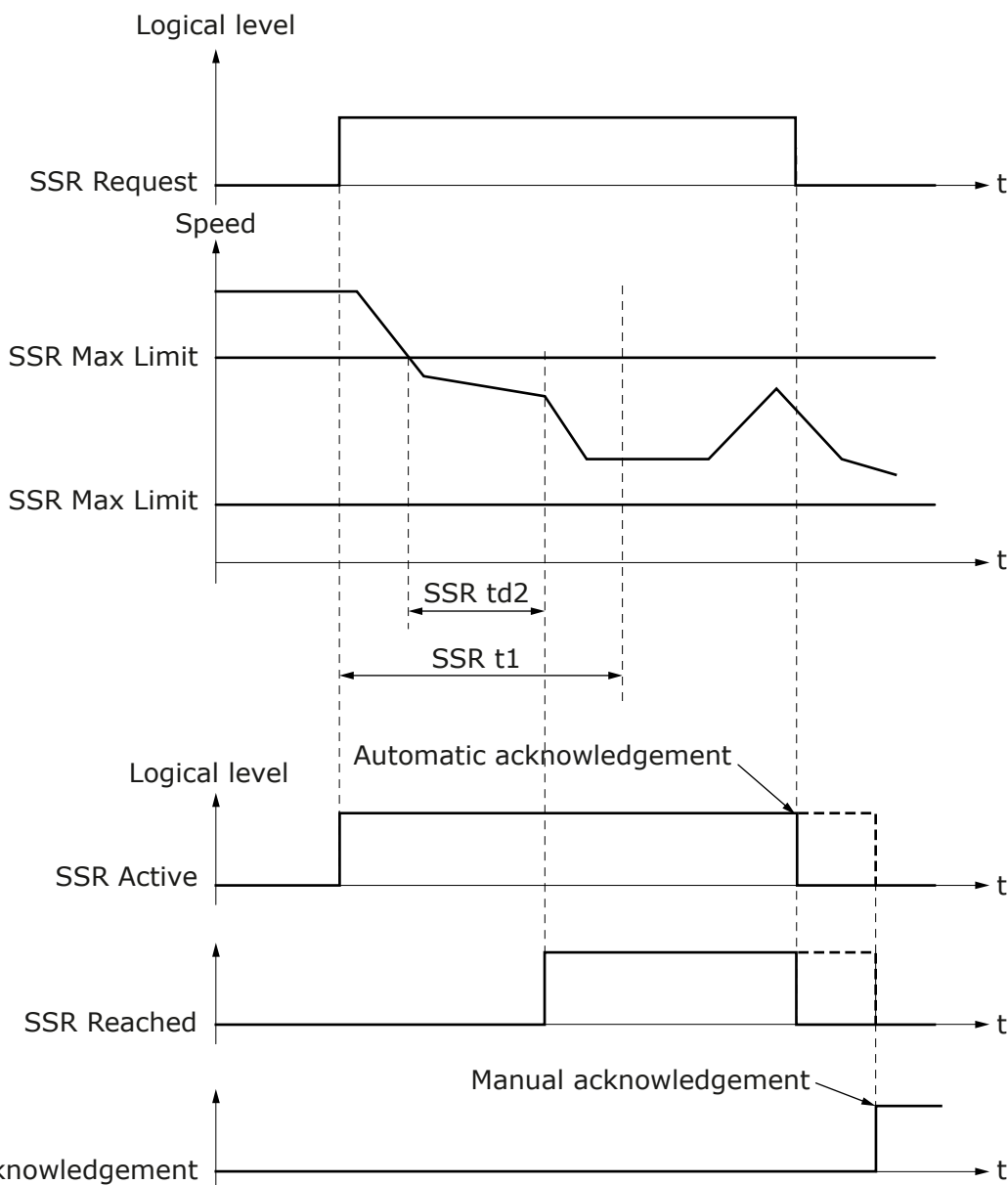

e30b1352.10

Illustration 61: The SSR Signals

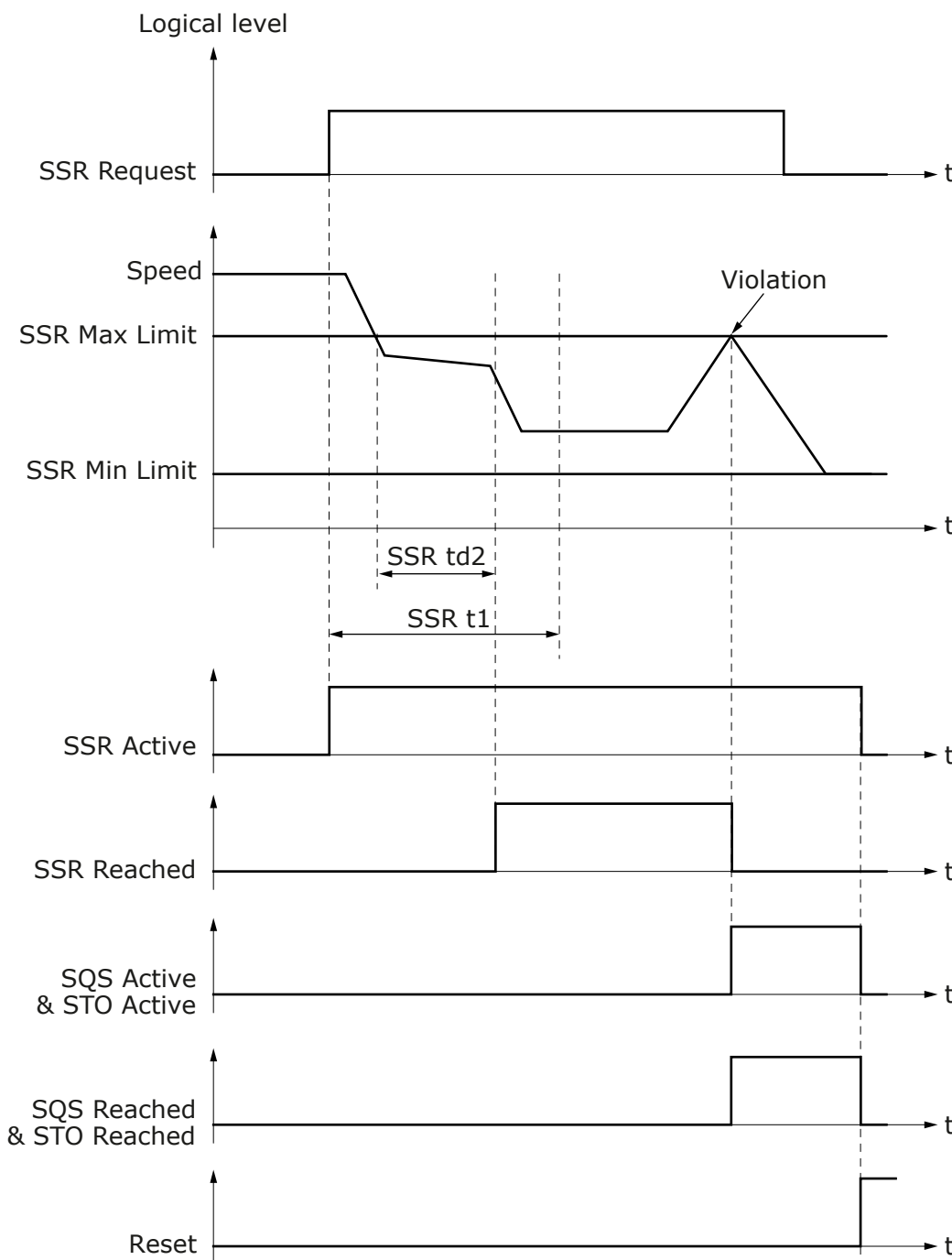

e30bi353.10

Illustration 62: The SSR Signals in a Violation Case. The SQS-STO Function as a Violation Response.

6.3.5 SSM - Safe Speed Monitor

6.3.5.1 Introduction to the SSM Function

The Safe Speed Monitor (SSM) safety function provides a safe output for signaling if the motor speed is within the set limits. It is possible to parameterize the maximum speed and the minimum speed.

The only response to the speed going outside the limits is the deactivation of the safe output. No other safety function is activated.

When the SSM function is set to "Always active", an acknowledgment is not necessary. When the SSM function is not "Always active", the acknowledgment is used normally, as specified in chapter [6.1.5.1 Acknowledgment of a Safety Function](#).

The parameters of the SSM safety function are described in [8.11 SSM Parameters](#).

6.3.5.2 Speed Monitoring

The monitoring starts when the SSM function is requested and becomes active. The monitoring of the maximum speed is specified in EN IEC 61800-5-2. The monitoring of the minimum speed is an extra feature that is not specified by the standard.

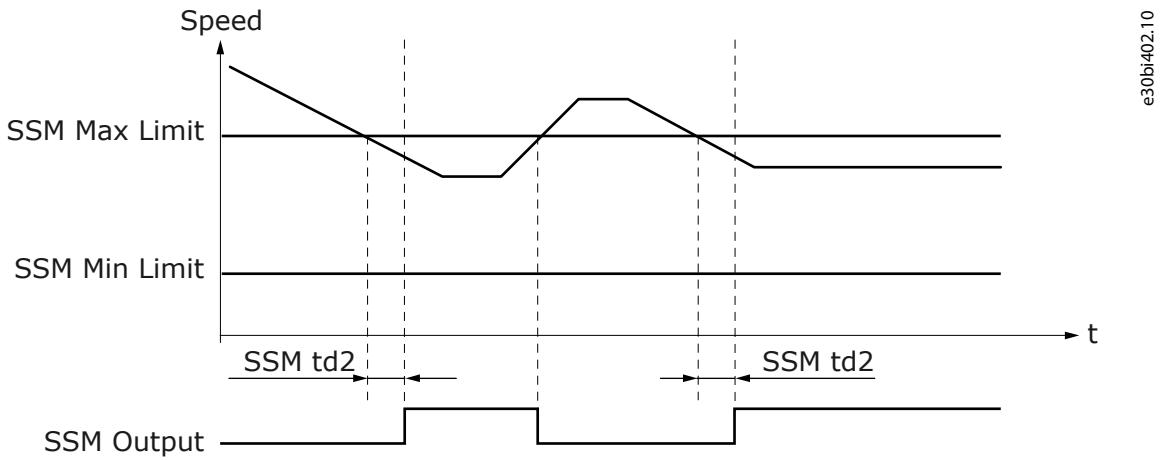

Illustration 63: The SSM Function with Monitoring of Both the Speed Limits. The SSM Function is Requested During the Sequence.

It is possible to disable the monitoring of a speed limit by setting its monitor value to 0 rpm. However, if the monitoring of the maximum speed is disabled, the SSM function cannot monitor excess speed.

The behavior of the function is the same for both the speed limits. See also [6.3.5.3 The SSM Safe Output](#).

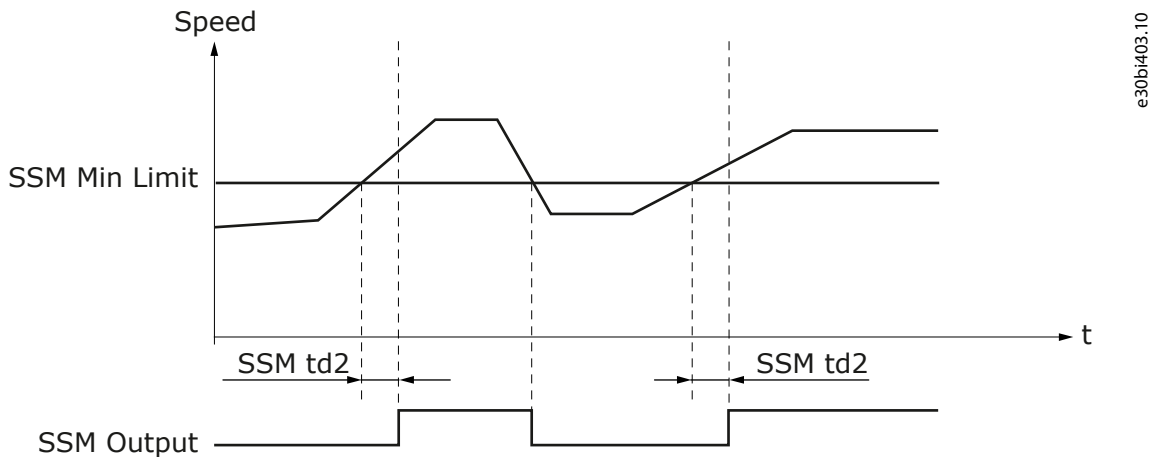

Illustration 64: The Minimum Speed Monitoring. The SSM Function is Requested During the Sequence.

NOTICE

The SSM function does not report a violation if the speed goes outside the range that is defined by the speed limits. Only the safe output signal indicates the situation.

Unlike other safe monitoring functions, the monitoring of the SSM function does not stop when a violation occurs in another safety function, or when the STO function becomes active. The SSM output and the SSM signals are updated throughout the violation situation and during the standstill caused by the STO function.

6.3.5.3 The SSM Safe Output

The state of the SSM safe output is determined by the speed of the motor and whether the SSM function is active. The table below shows the state of the SSM safe output and the SSM Reached signal that corresponds to the output state.

Table 40: The State of the SSM Safe Output

Condition	Speed	SSM Reached	SSM Out (DOUTx)
SSM requested (request active, even after a violation)	Actual speed inside the allowed range	Active	Active
	Actual speed outside the allowed range	Inactive	Inactive
SSM not requested (request not active)	Any	Inactive	Inactive
Fatal/Resettable Fault	–	Inactive	Inactive

The table below shows the behavior of signals SSM Below Min Limit and SSM Above Max Limit that indicate which limit the speed has crossed.

Table 41: Possible Combinations and the Results of the SSM Function

Condition	SSM Reached	SSM Below Min Limit	SSM Above Max Limit
SSM Min Limit ≤ actual speed ≤ SSM Max Limit or SSM Min Limit ≤ actual speed, SSM Max Limit = 0	1 (Active)	0	0
actual speed > SSM Max Limit	0 (Inactive)	0	1
actual speed < SSM Min Limit	0 (Inactive)	1	0
SSM not active or Fatal/Resettable Fault	0 (Inactive)	0	0

6.3.5.4 The SSM Signals

It is possible that the Active and Reached signals that are mentioned in this chapter are not always available in all interfaces.

NOTICE

The availability of the signals over safe fieldbus depends on the used fieldbus protocol. Refer to chapter Safe fieldbuses for more information.

NOTICE

The SSM signals are updated during the operation of the STO function, and during the violations of other safety functions.

Table 42: The SSM Signals

Signal	Activation and deactivation of the signal	Description
SSM Active	Activation: <ul style="list-style-type: none"> SSM is requested and starts execution. Deactivation (manual acknowledgment): <ul style="list-style-type: none"> Acknowledgment signal received and SSM is not requested. Deactivation (automatic acknowledgment): <ul style="list-style-type: none"> SSM request ends. Deactivation (SSM violation situations):	The signal indicates if the SSM function is being executed.

Signal	Activation and deactivation of the signal	Description
	<ul style="list-style-type: none"> - [No violations of SSM] 	
SSM Reached	<p>Activation:</p> <ul style="list-style-type: none"> Speed is within safe range for the time that is set with SSM td2. <p>Deactivation (manual acknowledgment):</p> <ul style="list-style-type: none"> SSM is acknowledged after being reached successfully. <p>Deactivation (automatic acknowledgment):</p> <ul style="list-style-type: none"> SSM was reached successfully and SSM request ends. <p>Deactivation (normal operation):</p> <ul style="list-style-type: none"> Speed goes outside the limits. <p>Deactivation (fault state):</p> <ul style="list-style-type: none"> A critical or removable fault is detected. 	The signal indicates if the SSM function has been reached successfully. Corresponds to the state of the SSM output.
SSM Above Max Limit	<p>Activation:</p> <ul style="list-style-type: none"> SSM is requested and speed is above maximum limit. <p>Deactivation (manual acknowledgment):</p> <ul style="list-style-type: none"> Speed is below maximum limit for the time that is set with SSM td2. OR Acknowledgment signal received and SSM is not requested. <p>Deactivation (automatic acknowledgment):</p> <ul style="list-style-type: none"> Speed is below maximum limit for the time that is set with SSM td2. OR SSM request ends. <p>Deactivation (normal operation):</p> <ul style="list-style-type: none"> Speed is within safe range for the time that is set with SSM td2 	The signal indicates if speed is above the SSM Max Limit.
SSM Below Min Limit	<p>Activation:</p> <ul style="list-style-type: none"> SSM is requested and speed is below minimum limit. <p>Deactivation (manual acknowledgment):</p> <ul style="list-style-type: none"> Speed is above minimum limit for the time that is set with SSM td2. OR Acknowledgment signal received and SSM is not requested. <p>Deactivation (automatic acknowledgment):</p> <ul style="list-style-type: none"> Speed is above minimum limit for the time that is set with SSM td2. OR SSM request ends. <p>Deactivation (normal operation):</p> <ul style="list-style-type: none"> Speed is within safe range for the time that is set with SSM td2. 	The signal indicates if speed is below the SSM Min Limit.

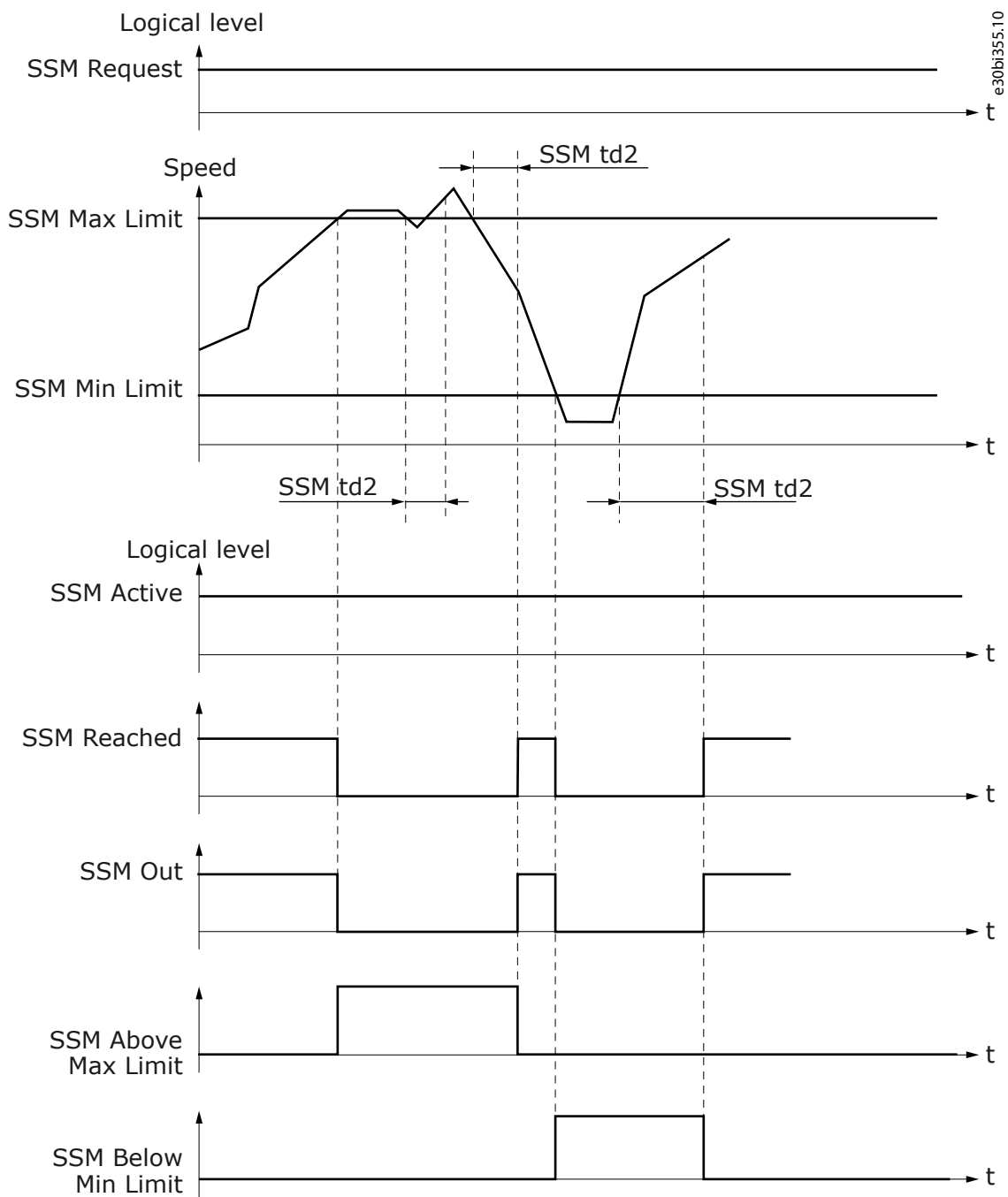

Illustration 65: The SSM Signals

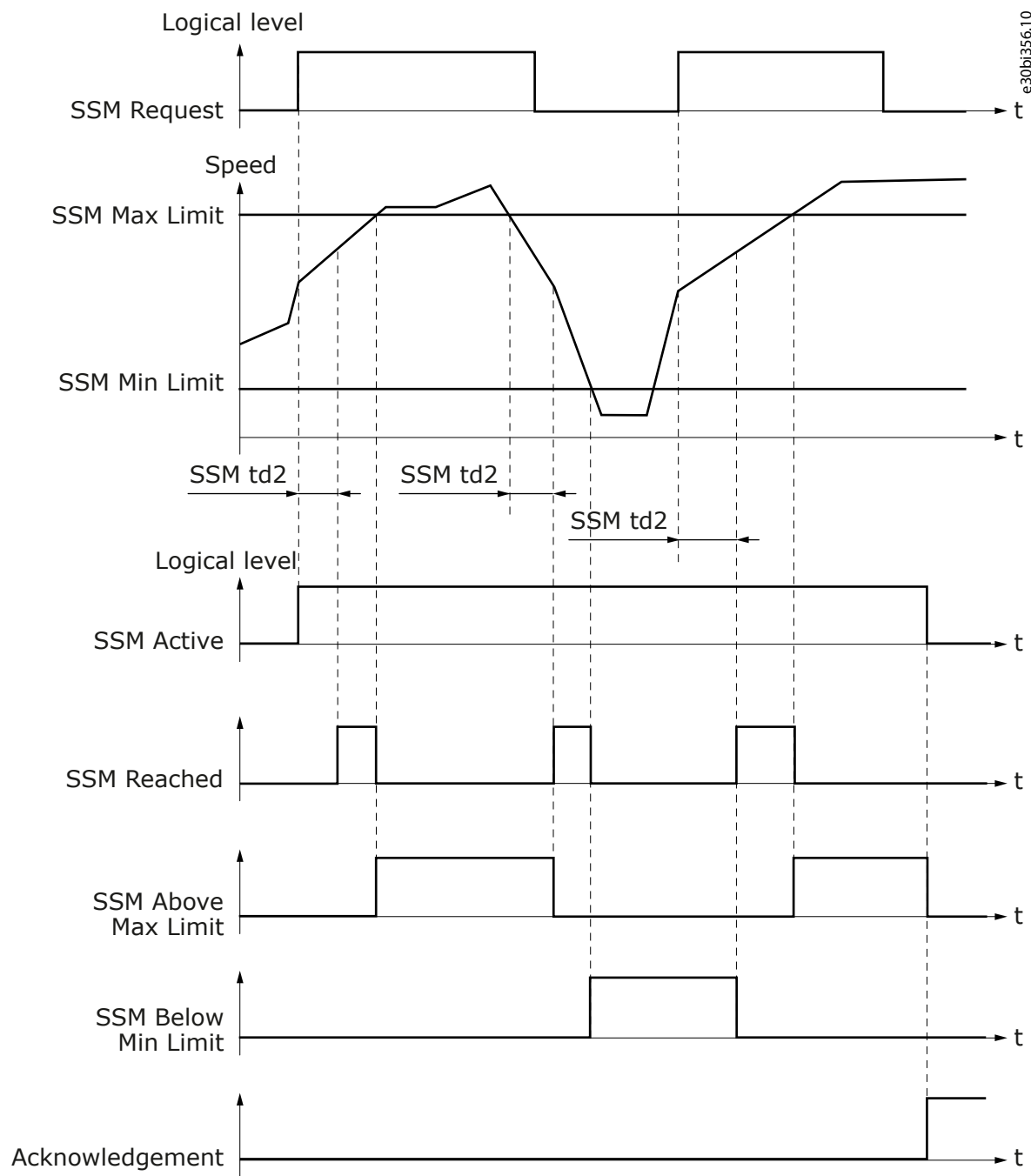

Illustration 66: The SSM Function Requested Externally, Manual Acknowledgment

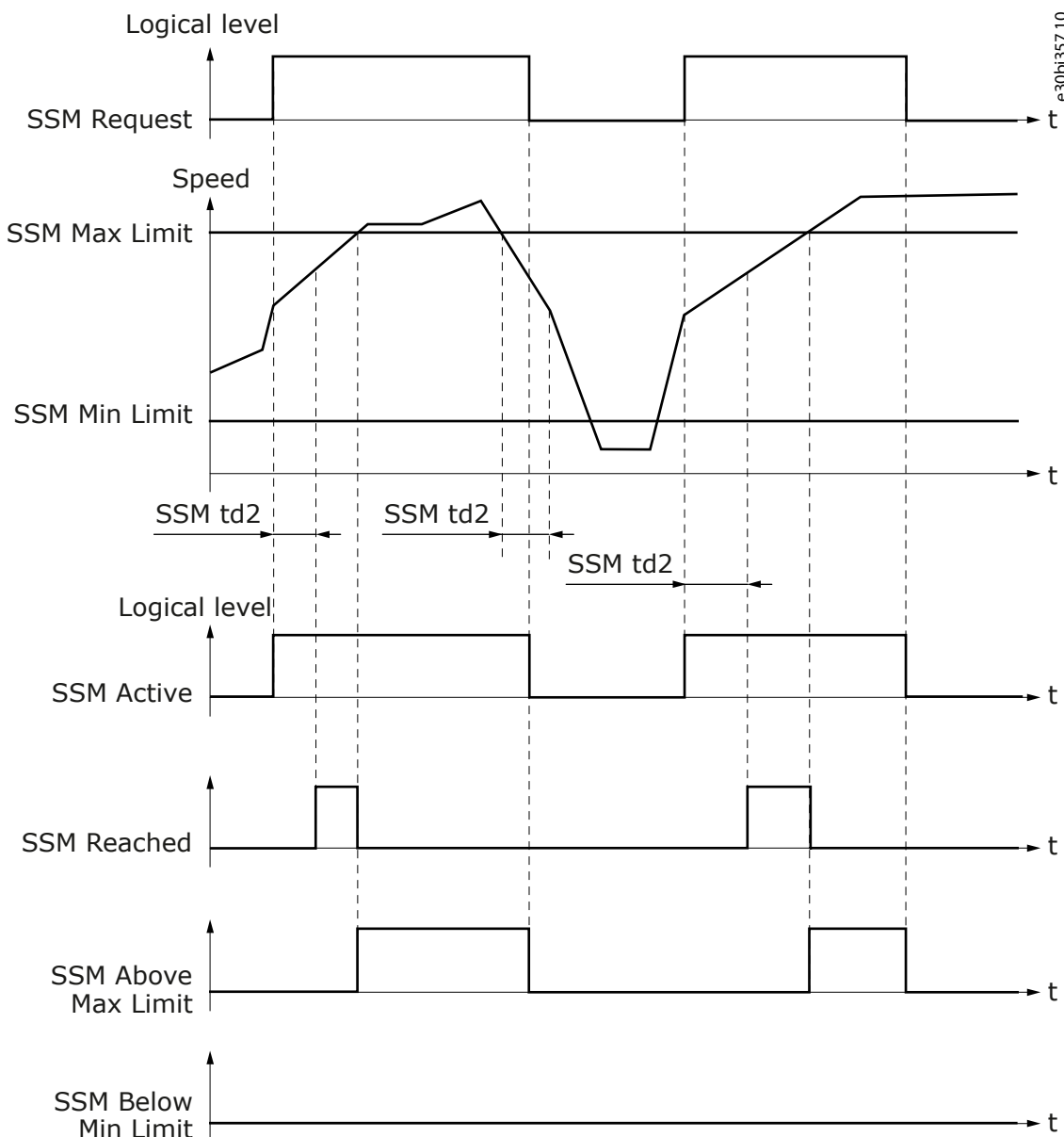

Illustration 67: The SSM Function Requested Externally, Automatic Acknowledgment

6.4 Combinations of Safety Functions

When many safety functions are used at the same time, all active safety functions execute the parameterized monitoring. Depending on the parameter settings of the functions and the system design, unexpected violations can occur.

NOTICE

The Advanced safety option board or the PC tool do not check if the parameter values of different safety functions are compatible.

NOTICE

When the first violation is detected, the other safe monitoring functions stop their monitoring until the violation is reset. The exception is the SSM function which continues to monitor the speed and update the output value.

Using the SSR function and a safe stopping function at the same time causes a conflicting situation. If the SSR function has a minimum limit value that is greater than zero, and is active during the execution of the SS1, the SS2, the SQS-SS1, or the SQS-SS2 func-

tions, the SSR function or the safe stopping function is likely to detect a violation. The safe stopping function aims to stop the motor, whereas the SSR function aims to keep the speed above the monitored minimum limit.

How to avoid a violation with the SSR function and a safe stopping function:

- Use the SS1 and the SQS-SS1 functions in the time monitoring mode. After the delay, the STO function is activated and the SSR monitoring is disabled. The situation after resetting the STO function still must be considered. The SSR must be reached before the time that is set with SSR t1 elapses.
- Deactivate the SSR function during the operation of safe stopping functions.

Do not use the SS2 function if you use the SSR function with a minimum limit value that is greater than zero, and if you cannot deactivate the SSR function during the operation of the SS2 function. The SSR function will detect a violation of the minimum limit, or the SOS function that is activated during the SS2 function will detect the rotation if the speed is still above SSR Min limit when the SOS function becomes active.

7 Safe Fieldbuses

7.1 PROFIsafe

7.1.1 Introduction to PROFIsafe

This chapter describes the Advanced safety system when PROFIsafe is enabled and a PROFIsafe-capable fieldbus option board is installed.

PROFIsafe is an additional safety protocol on top of a standard transmission system (PROFINET/PROFIBUS). PROFIsafe uses several technologies to ensure the validity and status of the fieldbus communication, making it reliable to use with safety devices. These measures include: consecutive numbering, watchdog time monitoring with acknowledgment, codename per communication relationship, and cyclic redundancy check for data integrity.

Communication over the non-safe transmission systems is called the "black channel".

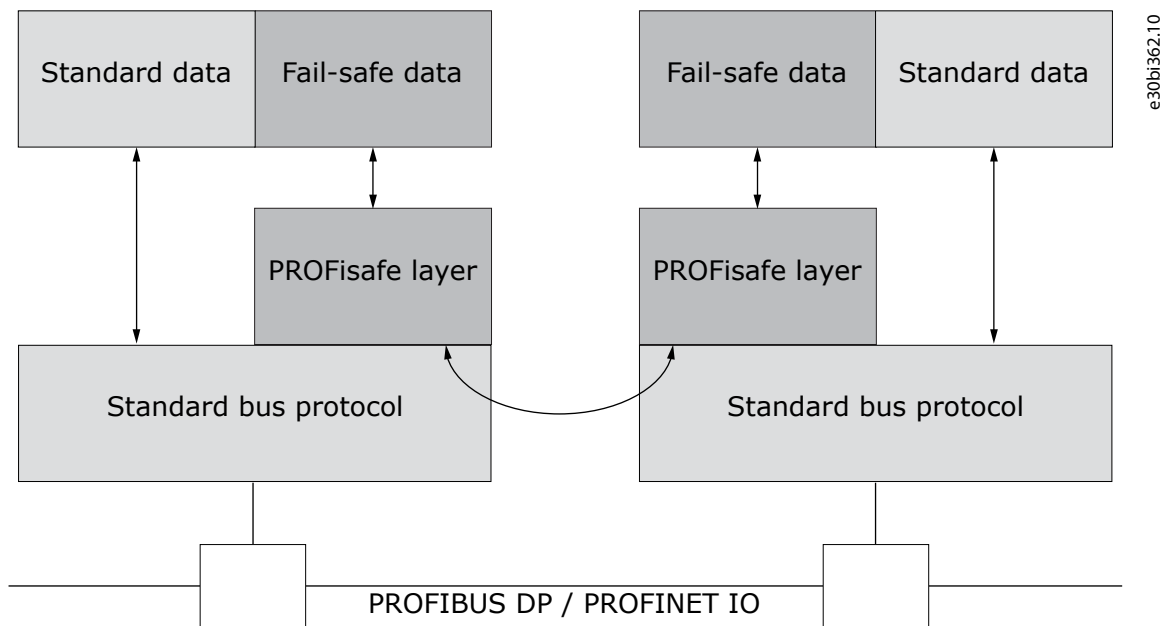

Illustration 68: PROFIsafe Communication

The Advanced safety option board supports version V2.4 of PROFIsafe in V2 mode. The PROFIsafe protocol can be used in applications with up to SIL 3 requirements according to IEC 61508 and the PROFIsafe communication is implemented according to IEC 61784-3.

7.1.2 The Requirements and Restrictions

To use PROFIsafe with the Advanced safety option board, the components of the table are required.

Table 43: The Required Components and Versions for PROFIsafe

Component	Version	Comment
The control board of the AC drive	System software: NXP00002V198 or newer Hardware: Serial number 761 or newer	–
OPTE3/E5 PROFIBUS option board	Firmware: FW0083V006 or later GSD file: Vac30CCF revision 2 or newer	–
The safety PLC	–	Must support PROFIsafe
OPTEA Advanced Dual Port Ethernet	Firmware FW0241V001 or later	–

NOTICE

The Advanced safety option board can be controlled with PROFIsafe and digital inputs at the same time, but in that case special consideration is necessary. The requests from both the sources will be taken into account in the status information of the digital output and the fieldbus status messages.

7.1.3 Overview of the PROFIsafe System

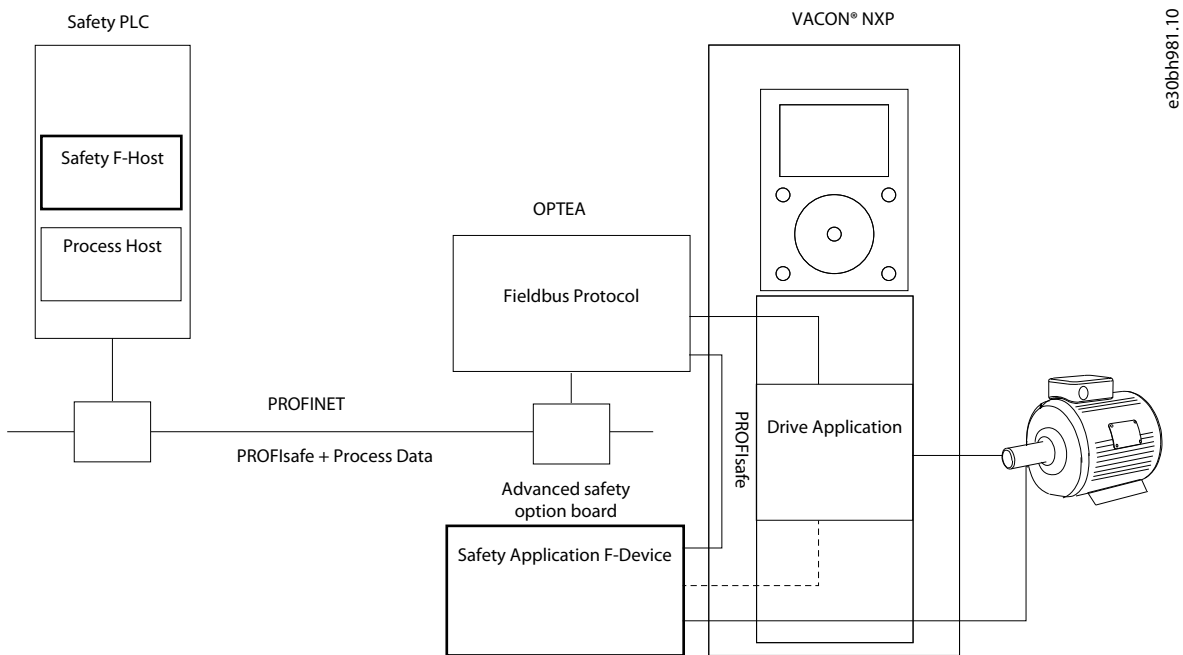

Illustration 69: Overview of the PROFIsafe system, with PROFIsafe used over PROFIBUS or PROFINET

The PROFIBUS option board (OPT3/E5) uses PROFIBUS and the PROFINET option board (OPT3/E5) uses PROFINET to communicate with the safety PLC. The exchanged data includes PROFIsafe data and non-safe process data. The PROFIsafe option boards extract the process data and the safety frame from the received message and forward them. The process data is sent to the drive application, and the safety frame is sent to the Advanced safety option board.

The Advanced safety option board receives and sends the PROFIsafe safety frames and implements the configured safety functions. The Advanced safety option board can also interact with the drive application, which can be parameterized to react to safety functions.

7.1.4 The PROFIsafe Frame

The PROFIsafe frame that is exchanged between the safety PLC (F-Host) and the safety slave (F-Device) includes the safety I/O data (F-I/O), a Status/Control byte, and a CRC signature. The safety I/O data is used to control the drive safety process, the Status/Control byte is used for the PROFIsafe communication, and the CRC signature ensures the validity of the frame.

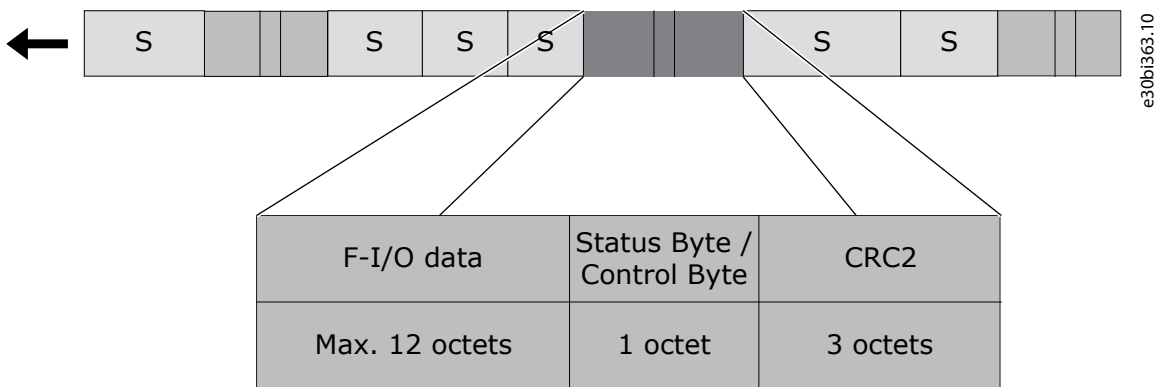

Illustration 70: The structure of the PROFIsafe frame. S = Standard frame

The Status and Control Bytes, which are used to indicate, monitor and set the safety status of the F-Device are described in [Table 44](#) and [Table 45](#). For more details, refer to PROFIsafe – Profile for Safety Technology on PROFIBUS DP and PROFINET IO Technical Specification.

Table 44: Description of PROFIsafe Status Byte

Bit	Signal	Description
0	iPar_OK	Not used
1	Device_Fault	Fault in F-Device
2	CE_CRC	Communication fault: CRC
3	WD_timeout	Communication fault: Watchdog timeout
4	FV_activated	Fail-safe values (FV) activated
5	Toggle_d	Toggle Bit (F-Device)
6	Cons_nr_R	Consecutive number has been reset
7	–	Reserved

Reaction to a device fault (F-Sub modules)

When the device is in fault state, the PLC/fieldbus does not need to prevent the intentional restart. ASO turns on this bit in PROFIsafe if it detects an illegal function in the software. The illegal functions include, for example, faulty messages sent by NXP, CPU overload (not having time to do everything necessary in a 1 ms cycle), CPU's own exceptions. To clear the error, boot the ASO.

Table 45: Description of PROFIsafe Control Byte

Bit	Signal	Description
0	iPar_EN	Not used
1	OA_Req	Operator acknowledgment
2	R_cons_nr	Reset consecutive number
3	–	Reserved
4	Activate_FV	Fail-safe values (FV) to be activated
5	Toggle_h	Toggle Bit (F-Host)
6	–	Reserved
7	–	Reserved

The supported formats for safety I/O data are described in [7.1.6.4 Data Mapping for PROFIdrive on PROFIsafe](#).

7.1.5 Parameterization for PROFIsafe

7.1.5.1 General Information on Parameterization

When using PROFIsafe, the protocol requires specific safety parameters (F-parameters) to be sent from F-Host to F-Device. These parameter values must be set to the Advanced safety option board with the VACON®Safe tool and to F-Host with its configuration tool. During start-up, the values on F-Host are transmitted to the Advanced safety option board, which does a check of the values against the values on the Advanced safety option board. The values configured to F-Host and F-Device must be the same for the safety communication to start.

The safety layer starts whenever the communication channel (PROFIBUS/PROFINET) is communicating cyclically. Refer to chapter "Commissioning" of the user guide of the used fieldbus. An unsuccessful initialization of the PROFIsafe protocol does not affect the PROFIBUS/PROFINET cyclic communication. The PROFIBUS/PROFINET cyclic communication can be used to read diagnostic information if the PROFIsafe parameterization fails.

See the PROFIsafe parameters in [8.3.1 PROFIsafe Parameters](#).

Table 46: Settings in the Safety PLC

Value	Description
F Source Address	The value must be the same as the F Source Address on the Advanced safety option board. The valid range is 1–65534.
F Destination Address	The value must be the same as the F Destination Address on the Advanced safety option board. The valid range is 1–65534.
F WD Time	The value must be the same as the F WD Time on the Advanced safety option board.
F iPar CRC	The value must be the same as the final CRC of the parameter file on the Advanced safety option board. The value can be seen in VACON [®] Safe after the verification of the parameter file is completed, on the control panel of the AC drive, or in the commissioning report printed from VACON [®] Safe.
Safety Telegram & F-I/O Data of the Safety Telegram	The value must be the same as the Safety telegram in the Advanced safety option board. F-I/O Data must be mapped as described in chapter Data mapping for PROFIdrive on PROFIsafe.

The following PROFIsafe-related parameters cannot be edited in the Advanced safety option board. They must have the same value in the safety PLC communication to the option board over PROFIsafe. The values of the Table 47 are defined in the fieldbus GSD description file that is provided for the fieldbus option board by VACON[®]; and must not be modified.

Table 47: The Uneditable F-Parameters

Parameter	Value	Unit	Description
F Check iPar	0 = NoCheck		Manufacturer-specific iPar check
F CRC Length	0 = 3-Byte-CRC		CRC2 signature length
F Block ID	1 = F iPar CRC within FParameter block		Parameter block type identification
F Par Version	1 = V2 Mode		Version number of F-Parameters
F SIL	8 = SIL3		Employed SIL level of F-Device

7.1.5.2 PROFIsafe Watchdog Time

Use the F-Parameter F WD Time to determine a watchdog time for the communication between F-Host and F-Device.

The minimum watchdog time has 4 parts:

- DAT = Device Acknowledgment Time. F-Device receives a frame, processes it, and prepares a new frame to be sent.
- Bus = The transfer time of the frame from the AC drive to F-Host.
- HAT = Host Acknowledgment Time. F-Host receives a frame, processes it, and generates a new frame.
- Bus = The transfer time of the frame from F-Host to the AC drive.

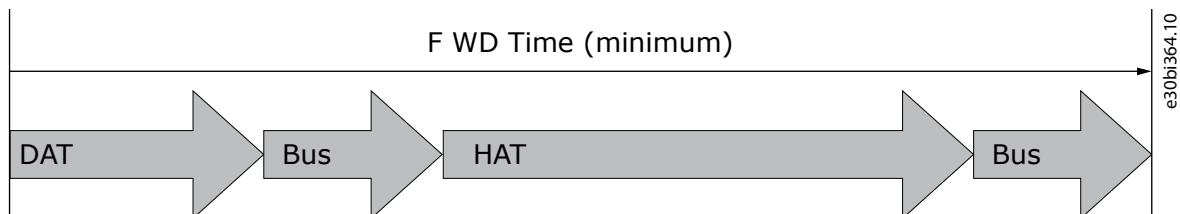

Illustration 71: The Parts of the Watchdog Time

It can sometimes be difficult to determine the bus transfer time that is used to calculate the watchdog time. For more information on the cycle times, see the user guide of the used fieldbus.

Use this formula to calculate the F WD Time:

$$FWD\ Time = DAT + HAT + 2 \times BT$$

Table 48: Description of the Parts of the Watchdog Time

Symbol	Name	Description
DAT	Device Acknowledgment Time	70 ms for the complete AC drive system
HAT	Host Acknowledgment Time	Application-specific
BT	Bus Cycle Time	The bus cycle time

The F-Parameter F WD Time must have a value that is slightly greater than the sum of DAT, HAT, and two times the bus transfer time. It is recommended not to exceed the calculated value by more than 30%. Setting a shorter watchdog time does not have an effect on the safety of a system, but it can cause a fault and make the AC drive trip.

For example, if HAT is 4 ms and the PROFIBUS cycle time is 3 ms, F WD Time should be set to:

$$F\ WD\ Time = (DAT + HAT + 2 \times BT) \times 1.3 = (70\ ms + 4\ ms + 2 \times 3\ ms) \times 1.3 = 104\ ms$$

For example, if HAT is 4 ms and the PROFINET cycle time is 4 ms, F WD Time should be set to:

$$F\ WD\ Time = (DAT + HAT + 2 \times BT) \times 1.3 = (70\ ms + 4\ ms + 2 \times 4\ ms) \times 1.3 = 110\ ms$$

If there is extreme electromagnetic interference, the communication systems use retry mechanisms to increase the robustness of the system. Before setting the F WD Time, it is recommended to find the number of retries of each connection and adjust the minimum watchdog time if necessary.

7.1.5.3 The PROFIsafe Safety Function Response Time (SFRT)

PROFIsafe specifies a safety function response time (SFRT), during which the safety system must react to a fault in the system. The SFRT includes all individual delays, including the bus transfer times. All of these elements have minimum and maximum delays, and the actual delay is likely to be somewhere in between these values. For safety reasons every communication cycle has its own watchdog time WDT_{Timei} after which the safe state is activated if a fault occurs in that communication cycle.

To calculate the safety function response time, use this formula:

$$SFRT = \sum_{i=1}^n WCDT_i + \max_{i=1,2,..,n} (WDT_{Time_i} - WCDT_i)$$

SFRT = Safety Function Response Time

WCDT_i = Worst Case Delay Time of entity i

WDT_{Timei} = Watchdog Time of entity i. See chapter [7.1.5.2 PROFIsafe Watchdog Time](#).

Adding the worst case delay times for components of the VACON[®] safety system gives the total Worst Case Delay Time.

Table 49: The Delays and Watchdog Times of a VACON[®] Safety System

Device	Worst case delay time	Watchdog time
The complete AC drive system	70 ms	Recommended 150 ms or larger

7.1.6 PROFIdrive on PROFIsafe

7.1.6.1 General Information on PROFIdrive on PROFIsafe

The PROFIdrive on PROFIsafe telegrams are mapped according to the PROFIdrive on PROFIsafe amendment. The selected data for controlling the safety functions is included in the PROFIsafe frame.

For the AC drive to fully comply with PROFIdrive on PROFIsafe, a compatible drive application must be used, for example the Multi-purpose Control Application, APFIF06.

NOTICE

Some values of some parameters in the Advanced safety option board are not compatible with PROFIdrive on PROFIsafe. The Advanced safety option board allows more detailed or different behavior for some safety functions than what is mentioned in the PROFIdrive on PROFIsafe amendment.

The compatibility only applies to the safety functions and features that are used. It is not necessary to take into account the safety functions and features that are not used. See [Table 50](#).

Table 50: The Compatibility of Parameters with PROFIdrive on PROFIsafe

Parameter	Range or Options	Unit	Description
Reset Drive	(Enabled) ⁽¹⁾ Disabled ⁽²⁾		PROFIdrive on PROFIsafe assumes that the fault log and the safety fault log are controlled separately. Only the safety system should be permitted to reset the safety faults.
Acknowledge drive	(Enabled) ⁽¹⁾ Disabled ⁽²⁾		The acknowledgment of safety functions from non-safe source not allowed.
Acknowledgment mode (all safety functions)	Manual ⁽³⁾ Automatic ⁽²⁾		Automatic mode assumed in PROFIdrive on PROFIsafe.
SSM mode	Always active ⁽²⁾		Safety Telegram 31 does not have control bit for SSM. Always active assumed.
SSM Min Limit	0	ms	Minimum speed monitoring not considered in PROFIdrive on PROFIsafe. Other values than zero cause also slow speeds to activate the SSM output of the drive, instead of just higher than SSM Max Limit speeds.

¹ The option is not compatible.

² The option is compatible.

³ The option can be used, but it is not mentioned in the PROFIdrive on PROFIsafe amendment.

PROFIdrive on PROFIsafe defines 4 SLS limits, but the Advanced safety option board only supports 3 SLS limits. The fourth limit selection is not used. An SLS request with the fourth limit selection is invalid and will cause a fault. See chapter [7.1.6.7 Safety Control Word 2 \(S_STW2\)](#).

The safety functions in the Advanced safety option board can be parameterized in more detail than what is described in the PROFIdrive on PROFIsafe amendment. If you use such details, take them into account with the F-Host.

7.1.6.2 PROFIsafe over PROFIBUS

When using PROFIBUS, the PROFIsafe data must always be in Slot 1. In the Advanced safety option board, only one Safety Telegram is permitted to be selected at once.

For information on the supported telegram combinations, see VACON® OPT3/E5 PROFIBUS Option Board Manual.

Table 51: The Structure of the PROFIBUS Message when PROFIsafe is Used

PROFIBUS header	PROFIsafe user data	PROFIsafe trailer	PROFIdrive user data	PROFIBUS trailer
–	F-I/O Data	Status/Control Byte + CRC2	–	–
–	F-Data (= PROFIdrive Safety Telegram)		For example PROFIdrive Telegram 1	–
–	Slot 1		Slot 2	–

The F-I/O Data consists of PROFIsafe user data, which consists of PROFIdrive Safety Signals. The Safety Signals inside the F-I/O Data together with the PROFIsafe trailer (see [7.1.4 The PROFIsafe Frame](#)) form the PROFIdrive Safety Telegram.

Table 52: The Structure of the F-Data

F-Data	
PROFIsafe user data (PROFIdrive Safety Signals)	PROFIsafe trailer
F-I/O Data	Status/Control Byte, CRC2

7.1.6.3 PROFIsafe over PROFINET

When PROFINET is used, the PROFIdrive data is always in slot 1 and the PROFIsafe data is in slot 2. If the used PLC software follows the restrictions in the OPTEA GSDML file, it is not possible to put different types of telegrams in the wrong slots.

For information on the supported telegram combinations, see VACON®-OPTEA Advanced Dual Port Ethernet Option Board Manual.

7.1.6.4 Data Mapping for PROFIdrive on PROFIsafe

This section describes the telegrams used for controlling the safety functionality of the AC drive with PROFIsafe.

The Advanced safety option board supports 3 safety telegrams consisting of both standard PROFIdrive on PROFIsafe functionality and a vendor-specific functionality. These telegrams are Standard Telegram 30, Standard Telegram 31, and the vendor-specific Telegram 58000.

Table 53: The Supported Safety Telegrams and the Used Safety I/O Data Format

Safety telegram	Control word	Status word
30	S_STW1	S_ZSW1
31	S_STW2	S_ZSW2
58000	VS_CW	VS_SW

NOTICE

For all safety output data (control word), a bit value 0 means "activate" and 1 "deactivate" a safety function. All unsupported, unused, or reserved bits, including safety functions not taken into use with VACON®Safe, must be set to 0. Setting their bit value to 1 causes a fault.

NOTICE

For all safety input data (status word), a bit value 1 means "active" and 0 "nonactive". All unsupported, unused, or reserved bits are set to 0.

7.1.6.5 Safety Control Word 1 (S_STW1)

When you use Standard Telegram 30, the control word is Safety Control Word 1. Byte 0 is standardized. Byte 1 is completely vendor-specific, and identical to Byte 3 of Safety Control Word 2 (S_STW2).

Table 54: Description of Safety Control Word 1 (S_STW1)

Byte	Bit	Name	Description	Signal	Reference
0	0	STO	Safe Torque Off	STO request	6.2.2.4 The STO and SBC Signals
	1	SS1	Safe Stop 1	SS1 request	6.2.3.5 The SS1 Signals
	2	SS2	Safe Stop 2	SS2 request	6.2.4.6 The SS2 and SOS Signals
	3	–	–	–	–
	4	SLS	Safe Limited Speed ⁽¹⁾	SLS 1 request	6.3.2.5 The SLS Signals
	5	–	–	–	–
	6	–	–	–	–

Byte	Bit	Name	Description	Signal	Reference
	7	INTERNAL_EVENT_ACK	Acknowledge safety fault buffer (1->0 edge)	Reset	6.1.6 Reset of a Safety Function
1	0	ACK_SAFETY	Acknowledge safety function (0->1 edge)	Acknowledgment	6.1.5.1 Acknowledgment of a Safety Function 6.1.5.2 Start-up Acknowledgment
	1	SS1/2_RAMP	0 = Ramp1, 1 = Ramp2, for SS1 and SS2	-	6.1.7 Ramps 6.2.3.4 Ramp Monitoring 6.2.4.4 Ramp Monitoring
	2	-	-	-	-
	3	SQS	Safe Quick Stop	SQS request	6.2.5.3 The SQS Signals
	4	SSR	Safe Speed Range	SSR request	6.3.4.4 The SSR Signals
	5	-	-	-	-
	6	SMS	Safe MaximumSpeed	SMS request	6.3.3.3 The SMS Signals
	7	-	-	-	-

¹ Always selects the SLS 1 function.

7.1.6.6 Safety Status Word 1 (S_ZSW1)

Safety Status Word 1 is used together with Safety Control Word 1 (S_STW1) to form Standard Telegram 30. Byte 0 is standardized. Byte 1 is vendor-specific and identical to Byte 3 of Safety Status Word 2 (S_ZSW2).

Table 55: Description of Safety Status Word 1 (S_ZSW1)

Byte	Bit	Name	Description	Signal	Reference
0	0	POWER_REMOVED	Safe Torque activated and torque removed from drive	STO Reached	6.2.2.4 The STO and SBC Signals
	1	SS1_ACTIVE	Safe Stop 1 activated ⁽¹⁾	SS1 Active or SQS Active	6.2.3.5 The SS1 Signals 6.2.5.3 The SQS Signals
	2	SS2_ACTIVE	Safe Stop 2 activated ⁽¹⁾	SS2 Active or SQS Active	6.2.4.6 The SS2 and SOS Signals 6.2.5.3 The SQS Signals
	3	SOS_ACTIVE	Safe Operating Stop activated	SOS Active	6.2.4.6 The SS2 and SOS Signals 6.2.5.3 The SQS Signals
	4	SLS_ACTIVE	Safe Limited Speed activated ⁽²⁾	SLS 1/2/3 Reached	6.3.2.5 The SLS Signals
	5	-	-	-	-
	6	-	-	-	-
	7	INTERNAL_EVENT	Drive Safety Process fault status	-	6.1.4 Violation of a Safety Function
1	0	SAFETY_EVENT	Unacknowledged safety functions active ⁽³⁾	Sum of all active safety functions	-
	1	-	-	-	-
	2	-	-	-	-
	3	SQS_ACTIVE	Safe Quick Stop activated	SQS Active	6.2.5.3 The SQS Signals

Byte	Bit	Name	Description	Signal	Reference
	4	SSR_ACTIVE	Safe Speed Range activated	SSR Reached	6.3.4.4 The SSR Signals
	5	–	–	–	–
	6	SMS_ACTIVE	Safe Maximum Speed activated	SMS Reached	6.3.3.3 The SMS Signals
	7	SBC_REACHED	Safe Brake Control output activated	SBC Reached	6.2.2.4 The STO and SBC Signals

¹ When the SQS function is executed in the drive: If the SQS-SS1/2 mode is used, the SS1/2 will be indicated by this bit. Depending on the parameterization, the SQS-SS1/2 can be different from the standard SS1/2.

² If any of the SLS functions is reached, this bit is set to 1.

³ This bit indicates whether there are safety functions active on the Advanced safety option board. This includes safety functions that are not indicated in the selected telegram but activated via a digital input. The SSM function is excluded if it is set to "Always active".

7.1.6.7 Safety Control Word 2 (S_STW2)

Compared to Safety Control Word 1, Safety Control Word 2 has two extra bytes, so Standard Telegram 31 can be used with more safety functions than Standard Telegram 30. With these bytes, it is possible to select between 3 different SLS limits and activate positive and negative safe direction functions. Byte 3 is identical to Byte 1 of Safety Control Word 1 (S_STW1).

Table 56: Description of Safety Control Word 2 (S_STW2)

Byte	Bit	Name	Description	Signal	Reference
0	0	STO	Safe Torque Off	STO request	6.2.2.4 The STO and SBC Signals
	1	SS1	Safe Stop 1	SS1 request	6.2.3.5 The SS1 Signals
	2	SS2	Safe Stop 2	SS2 request	6.2.4.6 The SS2 and SOS Signals
	3	–	–	–	–
	4	SLS	Safe Limited Speed ⁽¹⁾	SLS request	6.3.2.5 The SLS Signals
	5	–	–	–	–
	6	–	–	–	–
	7	INTERNAL_EVENT_ACK	Acknowledge safety fault buffer (1->0 edge)	Reset	6.1.6 Reset of a Safety Function
1	0	–	–	–	–
	1	SLS_LIMIT_BIT0	Bit 0 for coding SLS limit ⁽¹⁾	See Table 57 .	–
	2	SLS_LIMIT_BIT1	Bit 1 for coding SLS limit ⁽¹⁾	See Table 57 .	–
	3	–	–	–	–
	4	–	–	–	–
	5	–	–	–	–
	6	–	–	–	–
	7	–	–	–	–
2	0..7	–	–	–	–
3	0	ACK_SAFETY	Acknowledge safety function (0->1 edge)	Acknowledgment	6.1.5.1 Acknowledgment of a Safety Function 6.1.5.2 Start-up Acknowledgment

Byte	Bit	Name	Description	Signal	Reference
	1	SS1/2_RAMP	0 = Ramp1, 1 = Ramp2, for SS1 and SS2	–	6.1.7 Ramps 6.2.3.5 The SS1 Signals 6.2.4.6 The SS2 and SOS Signals
	2	–	–	–	–
	3	SQS	Safe Quick Stop	SQS request	6.2.5.3 The SQS Signals
	4	SSR	Safe Speed Range	SSR request	6.3.4.4 The SSR Signals
	5	–	–	–	–
	6	SMS	Safe MaximumSpeed	SMS request	6.3.3.3 The SMS Signals
	7	–	–	–	–

¹ The actual selection for the monitoring limit is made with SLS_LIMIT_BIT0 and SLS_LIMIT_BIT1. See [Table 57](#).

Table 57: SLS Limit Selection

SLS_LIMIT_BIT		SLS LIMIT
1	0	
0	0	SLS 1 Limit is selected when SLS (Byte 0, bit 4) is set to 0.
0	1	SLS 2 Limit is selected when SLS (Byte 0, bit 4) is set to 0.
1	0	SLS 3 Limit is selected when SLS (Byte 0, bit 4) is set to 0.
1	1	No SLS limit requested. SLS (Byte 0, bit 4) must be set to 1.

7.1.6.8 Safety Status Word 2 (S_ZSW2)

Safety Status Word 2 is used together with Safety Control Word 2 (S_STW2) to form Standard Telegram 31. Compared to Safety Status Word 1, Safety Status Word 2 has multiple SLS limits and the SSM function status.

Table 58: Description of Safety Status Word 2 (S_ZSW2)

Byte	Bit	Name	Description	Signal	Reference
0	0	POWER_REMOVED	Safe Torque activated and torque removed from drive	STO Reached	6.2.2.4 The STO and SBC Signals
	1	SS1_ACTIVE	Safe Stop 1 activated ⁽¹⁾	SS1 Active or SQS Active	6.2.3.5 The SS1 Signals 6.2.5.3 The SQS Signals
	2	SS2_ACTIVE	Safe Stop 2 activated ⁽¹⁾	SS2 Active or SQS Active	6.2.4.6 The SS2 and SOS Signals 6.2.5.3 The SQS Signals
	3	SOS_ACTIVE	Safe Operating Stop activated	SOS Active	6.2.4.6 The SS2 and SOS Signals 6.2.5.3 The SQS Signals
	4	SLS_ACTIVE	Safe Limited Speed activated ⁽²⁾	SLS 1/2/3 Reached	6.3.2.5 The SLS Signals
	5	–	–	–	–
	6	–	–	–	–
	7	INTERNAL_EVENT	Drive Safety Process fault status		6.1.4 Violation of a Safety Function
1	0	–	–	–	–

Byte	Bit	Name	Description	Signal	Reference
	1	SLS_LIMIT_BIT0_ACTIVE	Bit 0 coding for SLS limit ⁽³⁾	See Table 59	6.3.2.5 The SLS Signals
	2	SLS_LIMIT_BIT1_ACTIVE	Bit 1 coding for SLS limit ⁽³⁾	See Table 59	6.3.2.5 The SLS Signals
	3	–	–	–	–
	4	–	–	–	–
	5	–	–	–	–
	6	–	–	–	–
	7	SSM	Drive absolute speed safe status ⁽⁴⁾	SSM Reached	6.3.5.4 The SSM Signals
2	0..7	–	–	–	–
3	0	SAFETY_EVENT	Unacknowledged safety functions active ⁽⁵⁾	Sum of all requested and active safety functions	–
	1	–	–	–	–
	2	–	–	–	–
	3	SQS_ACTIVE	Safe Quick Stop activated	SQS Active	6.2.5.3 The SQS Signals
	4	SSR_ACTIVE	Safe Speed Range activated	SSR Reached	6.3.4.4 The SSR Signals
	5	–	–	–	–
	6	SMS_ACTIVE	Safe Maximum Speed activated	SMS Reached	6.3.3.3 The SMS Signals
7	SBC_REACHED	Safe Brake Control output activated	SBC Reached	6.2.2.4 The STO and SBC Signals	

¹ When the SQS function is executed in the drive: If the SQS-SS1/2 mode is used, the SS1/2 will be indicated by this bit. Depending on parameterization, the SQS-SS1/2 can be different from the standard SS1/2.

² Reached SLS_Limit is described by bits SLS_LIMIT_BIT0_ACTIVE & SLS_LIMIT_BIT1_ACTIVE.

³ Only valid, when SLS_ACTIVE bit is set to 1, otherwise this bit should be ignored.

⁴ Compatible with the PROFIdrive on PROFIsafe amendment if the SSM function is set to "Always active" and SSM_Min_Limit = 0, see [7.1.5.1 General Information on Parameterization](#).

⁵ This bit indicates whether there are safety functions active on the Advanced safety option board. This includes safety functions that are not indicated in the selected telegram but activated via a digital input. The SSM function excluded if it is set to "Always active".

Table 59: SLS Limit Status

Active signal	SLS_LIMIT_BIT_ACTIVE	
	1	0
SLS not reached	0	0
SLS 1 Reached	0	1
SLS 2 Reached	1	0
SLS 3 Reached	1	1

7.1.6.9 VACON Safety Control Word (VS_CW)

The standard S_STW1 and S_STW2 do not include all safety functions that are supported by the Advanced safety option board. However, a vendor-specific VACON Safety Control Word provides a full access to the safety functions and some extra features over fieldbus. The bit value 1 means that the signal is "non-active" and the value 0 means "active". All unused bits must be set to 0. Setting their bit value to 1 will cause a fault.

Table 60: Description of VACON Safety Control Word (VS_CW)

Byte	Bit	Name/Signal	Description	Reference
0	0	STO Request	Safe Torque Off	6.2.2.4 The STO and SBC Signals
	1	SS1 Request	Safe Stop 1	6.2.3.5 The SS1 Signals
	2	SS2 Request	Safe Stop 2	6.2.4.6 The SS2 and SOS Signals
	3	SQS Request	Safe Quick Stop	6.2.5.3 The SQS Signals
	4	SSR Request	Safe Speed Range	6.3.4.4 The SSR Signals
	5	SLS Request bit0	Safe Limited Speed. See Table 61 .	6.3.2.5 The SLS Signals
	6	SLS Request bit1	Safe Limited Speed. See Table 61 .	6.3.2.5 The SLS Signals
	7	–	–	–
1	0	–	–	–
	1	–	–	–
	2	SSM Request	Safe Speed Monitor ⁽¹⁾	6.3.5.4 The SSM Signals
	3	SMS Request	Safe Maximum Speed	6.3.3.3 The SMS Signals
	4	–	–	–
	5..7	–	–	–
2–4	0..7	–	–	–
5	0	SS1_Ramp_Select	Ramp selection (0 = Ramp1, 1 = Ramp2) for SS1 ⁽²⁾	6.2.3.5 The SS1 Signals
	1	SS2_Ramp_Select	Ramp selection (0 = Ramp1, 1 = Ramp2) for SS2 ⁽²⁾	6.2.4.6 The SS2 and SOS Signals
	2..5	–	–	–
	6	INTERNAL_EVENT_ACK / Reset	Acknowledge safety fault buffer (1 -> 0 edge)	6.1.6 Reset of a Safety Function
	7	ACK_SAFETY / Acknowledgment	Acknowledge safety function (0 -> 1 edge)	6.1.5.1 Acknowledgment of a Safety Function

¹ The SSM function can be parameterized to be always active. In this case, the selector bit has no function.

² Only when the safety function is parameterized to use ramp selection from the fieldbus.

Table 61: SLS Limit Selection

SLS Request Bit		SLS Limit
1	0	
0	0	SLS 1 Limit
0	1	SLS 2 Limit
1	0	SLS 3 Limit
1	1	No SLS limit requested

7.1.6.10 VACON Safety Status Word (VS_SW)

When using a vendor-specific Telegram 58 000, VACON Safety Status Word is used for the input data. VACON Safety Status Word includes the activation and the reached status of all safety functions, and the statuses of the safe digital inputs and outputs for monitoring purposes.

The bit value 1 means that the signal is "active" and the value 0 means "non-active". All unused bits are set to 0.

Table 62: Description of VACON Safety Status Word (VS_SW)

Byte	Bit	Name/Signal	Description	Reference
0	0	STO Reached	Safe Torque Off is active and torque is removed from the drive	6.2.2.4 The STO and SBC Signals
	1	SS1 Reached	Safe Stop 1 reached	6.2.3.5 The SS1 Signals
	2	SS2 Reached	Safe Stop 2 reached	6.2.4.6 The SS2 and SOS Signals
	3	SQS Reached	Safe Quick Stop reached	6.2.5.3 The SQS Signals
	4	SSR Reached	Safe Speed Range reached	6.3.4.4 The SSR Signals
	5	SLS 1 Reached	Safe Limited Speed Limit1 reached	6.3.2.5 The SLS Signals
	6	SLS 2 Reached	Safe Limited Speed Limit2 reached	6.3.2.5 The SLS Signals
	7	SLS 3 Reached	Safe Limited Speed Limit3 reached	6.3.2.5 The SLS Signals
1	0	–	–	–
	1	–	–	–
	2	SSM Reached	Safe Speed Monitor reached	6.3.5.4 The SSM Signals
	3	SMS Reached	Safe Maximum Speed reached	6.3.3.3 The SMS Signals
	4	–	–	–
	5	SOS Reached	Safe Operating Stop reached	6.2.4.6 The SS2 and SOS Signals
	6	SBC Reached	Safe Break Control reached	6.2.2.4 The STO and SBC Signals
	7	–	–	–
2	0	STO Active	Safe Torque Off activated	6.2.2.4 The STO and SBC Signals
	1	SS1 Active	Safe Stop 1 activated	6.2.3.5 The SS1 Signals
	2	SS2 Active	Safe Stop 2 activated	6.2.4.6 The SS2 and SOS Signals
	3	SQS Active	Safe Quick Stop activated	6.2.5.3 The SQS Signals

Byte	Bit	Name/Signal	Description	Reference
	4	SSR Active	Safe Speed Range activated	6.3.4.4 The SSR Signals
	5	SLS 1 Active	Safe Limited Speed Limit1 activated	6.3.2.5 The SLS Signals
	6	SLS 2 Active	Safe Limited Speed Limit2 activated	6.3.2.5 The SLS Signals
	7	SLS 3 Active	Safe Limited Speed Limit3 activated	6.3.2.5 The SLS Signals
3	0	–	–	–
	1	–	–	–
	2	SSM Active	Safe Speed Monitor activated	6.3.5.4 The SSM Signals
	3	SMS Active	Safe Maximum Speed activated	6.3.3.3 The SMS Signals
	4	–	–	–
	5...7	–	–	–
4	0	SSM_Above_Max_Limit	–	6.3.5.4 The SSM Signals
	1	SSM_Below_Min_Limit	–	6.3.5.4 The SSM Signals
	2	SF_Activity	Shows if any safety function is active ⁽¹⁾	
	3...6	–	–	–
	7	Advanced safety optionboard in error state		
5	0	DIN1	Safe Digital Input 1 state	3.4 Determining the Achieved Safety Level
	1	DIN2	Safe Digital Input 2 state	3.4 Determining the Achieved Safety Level
	2	DIN3	Safe Digital Input 3 state	3.4 Determining the Achieved Safety Level
	3	DIN4	Safe Digital Input 4 state	3.4 Determining the Achieved Safety Level
	4	DOUT1	Safe Digital Output 1 state	3.4 Determining the Achieved Safety Level
	5	DOUT2	Safe Digital Output 2 state	3.4 Determining the Achieved Safety Level
	6..7	–	–	–

¹ When the SSM function is parameterized to "Always active", it is not included in this bit.

8 Parameter List

8.1 General Parameters

8.1.1 Parameter File Parameters

Table 63: Parameter File Parameters

Parameter	Selection	Unit	Description
File Name	A maximum of 32 ASCII characters.	–	Use this parameter to give a name for this parameter file. The first 12 characters are visible on the control panel of the drive.
File Creator	A maximum of 32 ASCII characters.	–	Use this parameter to write the name of the person who created the parameter file. The first 12 characters are visible on the control panel of the drive.
File Date	–	–	Use this parameter to select the creation date of the parameter file.
Company	A maximum of 32 ASCII characters.	–	Use this parameter to write the name of the employer of the file creator.
Comment	A maximum of 120 ASCII characters.	–	Use this parameter to write a description of the parameter file.

8.1.2 Common Safety Function Parameters

Table 64: Common Safety Function Parameters

Parameter	Selection	Unit	Description
Zero Speed	1...999	rpm	Use this parameter to set the speed at which the motor is considered to be stopped. The safe stopping functions become reached at this speed. Zero Speed is also used in other situations. For example, the SS2 function activates the SOS function after the speed has reached Zero Speed and the time set with SS2 td2 has passed.
Drive Acknowledgment	Enabled Disabled	–	Use this parameter to select whether the control board of the drive is permitted to acknowledge safety functions in the Advanced safety option board. The source of the acknowledgment can be, for example, the control panel of the drive or a non-safe fieldbus.
Drive Reset	Enabled Disabled	–	Use this parameter to select whether the control board of the drive is permitted to reset faults in the Advanced safety option board. The source of the reset can be, for example, the control panel of the drive or a non-safe fieldbus.
Acknowledgment Mode (Start-up)	Manual Automatic	–	Use this parameter to select whether a manual (external) acknowledgment is necessary to deactivate the STO function after the start-up of the AC drive. If you select automatic , the STO function is deactivated after a successful start-up.

8.1.3 Speed Measurement Parameters

Table 65: Speed Measurement Parameters

Parameter	Selection	Unit	Description
Encoder Type	No encoder Sin/Cos Two Proximity sensors HTL and proximity sensor TTL and proximity sensor HTL and estimated speed TTL and estimated speed Sin/Cos and proximity sensor	–	Use this parameter to select the encoder type. With a Sin/Cos or a TTL encoder, it is necessary to define whether termination is used on the encoder interface board. See 3.6.4 Encoders .

Parameter	Selection	Unit	Description
	Sin/Cos with termination Sin/Cos with termination and proximity sensor TTL with termination and proximity sensor TTL with termination and estimated speed Proximity sensor and estimated speed		
Encoder Power Supply	5 12 15 24	V	Use this parameter to select the power supply voltage for the encoder.
Encoder Reference Signal	Reference Signal Used No Reference Signal	–	Use this parameter to set the reference signal on or off.
Encoder Number of Pulses	1...65535	–	Use this parameter to select the number of pulses per revolution of the encoder.
Proximity Sensor Number of Pulses	1...100	–	Use this parameter to select the number of pulses per revolution of the proximity sensor.
Proximity Sensor Duty Cycle	1...99	%	Use this parameter to select the duty cycle of the proximity sensor, that is, the active/inactive signal ratio. Other ratios than 50% (1:1) will decrease the supported maximum frequency of the proximity sensor signals. This parameter is used to determine that the frequency of the input signal will not exceed the detection capability and cause pulses to be lost.
Gear Ratio Divider	1...65535	–	Use this parameter together with Gear Ratio Multiplier to set the ratio between the speed measured by an external sensor and the estimated speed.
Gear Ratio Multiplier	1...65535	–	Use this parameter together with Gear Ratio Divider to set the ratio between the speed measured by an external sensor and the estimated speed.
Allowed Deviation of Speed Sources	0...1000	rpm	Use this parameter to set the allowed deviation between the two speed sources.
Speed Deviation Timer	0...5000	ms	Use this parameter to set the time that the value of Allowed Deviation of Speed Sources can be exceeded.

8.1.4 Ramp Parameters

Table 66: Ramp Parameters

Parameter	Selection	Unit	Description
Ramp1 Speed	0...65535	rpm	Use this parameter to set the nominal speed that is used to define the ramp 1.
Ramp1 Acc Time Min	0...3 000 000	ms	Use this parameter to set the minimum time for the speed to accelerate from zero to Ramp1 Speed.
Ramp1 Acc Time Max	0...3 000 000	ms	Use this parameter to set the maximum time for the speed to accelerate from zero to Ramp1 Speed.

Parameter	Selection	Unit	Description
Ramp1 Dec Time Min	0...3 000 000	ms	Use this parameter to set the minimum time for the speed to decelerate from Ramp1 Speed to zero.
Ramp1 Dec Time Max	0...3 000 000	ms	Use this parameter to set the maximum time for the speed to decelerate from Ramp1 Speed to zero.
Ramp2 Speed	0...65535	rpm	Use this parameter to set the nominal speed that is used to define the ramp 2.
Ramp2 Acc Time Min	0...3 000 000	ms	Use this parameter to set the minimum time for the speed to accelerate from zero to Ramp2 Speed.
Ramp2 Acc Time Max	0...3 000 000	ms	Use this parameter to set the maximum time for the speed to accelerate from zero to Ramp2 Speed.
Ramp2 Dec Time Min	0...3 000 000	ms	Use this parameter to set the minimum time for the speed to decelerate from Ramp2 Speed to zero.
Ramp2 Dec Time Max	0...3 000 000	ms	Use this parameter to set the maximum time for the speed to decelerate from Ramp2 Speed to zero.

8.1.5 Estimated Speed Parameters

Table 67: Estimated Speed Parameters

Parameter	Selection	Unit	Description
Coast Stop Time	0...10800	s	Use this parameter to set the time that it is estimated for the motor to coast to stop after the drive stops operating. The set value must be maximum 3 hours.

8.2 Safe I/O Parameters

8.2.1 Digital Input/Output Parameters

Table 68: Digital Input/Output Parameters

Parameter	Selection	Unit	Description
Digital Input 1 Digital Input 2 Digital Input 3 Digital Input 4	STO(+SBC) SS1 SS2 + SOS SQS SLS input 1 SLS input 2 SSR SSM SMS SS1 Ramp SS2 Ramp Acknowledgment Reset Acknowledgment + Reset	–	Use this parameter to select the function for a digital input. The configuration of an input is disabled if a proximity sensor is used for that input. Digital Input 1: one proximity sensor, and Digital Input 1 & 2: two proximity sensors.
Digital Output 1	SSM SBC Group 1 Group 2 Group 3	–	Use this parameter to select the function for the digital output.

Parameter	Selection	Unit	Description
	Group 4		
Digital Output 2	SSM SBC Group 5 Group 6 Group 7 Group 8	–	Use this parameter to select the function for the digital output.
Operation for Output 1 Operation for Output 2	AND OR NAND NOR	–	Use this parameter to select the logical function used to determine the output value from the selected signals. It is used when a group is selected for the output.
Group 1 for safe digital output 1 Group 2 for safe digital output 1 Group 3 for safe digital output 1 Group 4 for safe digital output 1 Group 5 for safe digital output 2 Group 6 for safe digital output 2 Group 7 for safe digital output 2 Group 8 for safe digital output 2	Group 1 and Group 5 <ul style="list-style-type: none"> • STO Reached • SS1 Reached • SS2 Reached • SQS Reached • SOS Reached • SBC Reached • STO and SBC Reached Group 2 and Group 6 <ul style="list-style-type: none"> • SLS 1 Reached • SLS 2 Reached • SLS 3 Reached • SSR Reached • SMS Reached • SSM Reached • SSM Above Max Limit • SSM Below Min Limit 	–	Use this parameter to select which signals are used to generate the output value. A checkbox selection.
Group 1 for safe digital output 1 Group 2 for safe digital output 1 Group 3 for safe digital output 1 Group 4 for safe digital output 1 Group 5 for safe digital output 2 Group 6 for safe digital output 2 Group 7 for safe digital output 2 Group 8 for safe digital output 2	Group 3 and Group 7 <ul style="list-style-type: none"> • STO Active • SS1 Active • SS2 Active • SQS Active • SLS 1 Active • SLS 2 Active • SLS 3 Active • SSR Active • SMS Active • SSM Active Group 4 and Group 8	–	Use this parameter to select which signals are used to generate the output value. A checkbox selection.

Parameter	Selection	Unit	Description
	<ul style="list-style-type: none"> Warning in any safety function Limit violation error in any safety function 		

8.3 Safe Fieldbus Parameters

8.3.1 PROFIsafe Parameters

Table 69: PROFIsafe Parameters

Parameter	Selection	Unit	Description
Fieldbus type	PROFIsafe	–	Use this parameter to select the safe fieldbus.
F Source Address	1...65534	–	Use this parameter to set a codename between sender and recipient. The source address must be unique within a subnet.
F Destination Address	1...65534	–	Use this parameter to set a codename between sender and recipient. The destination address must be unique within a subnet.
F WD Time	20...65535	ms	Use this parameter to set the PROFIsafe watchdog time in F-Device. See 7.1.5.2 PROFIsafe Watchdog Time .
Safety Telegram	3031 58000	–	Use this parameter to select the safety telegram. See 7.1.6.4 Data Mapping for PRO-Fldrive on PROFIsafe .

8.4 STO and SBC Parameters

Table 70: STO and SBC Parameters

Parameter	Selection	Unit	Description
Acknowledgment Mode (STO)	Manual Automatic	–	Use this parameter to select if manual (external) acknowledgment is necessary to deactivate the safety function after the request ends. If the selection is automatic, the function is deactivated after the request ends.

Table 71: SBC Parameters

Parameter	Selection	Unit	Description
SBC Enabled	–	–	Use this parameter to enable the SBC safety function.
SBC Order	SBC first STO first	–	Use this parameter to select which safety function activates first when the conditions for activation apply. The second safety function activates after the time set with SBC t1. See the tables in 6.2.2.3 The STO Function Used with the SBC Function .
SBC t1	0...99.9	s	Use this parameter to set the delay between the activation of the STO and the SBC functions. See the tables in 6.2.2.3 The STO Function Used with the SBC Function . This parameter is only valid for the activation. The deactivation of the STO and the SBC functions always occurs simultaneously.
SBC Speed	0...999	rpm	Use this parameter to set the speed at which the first function, STO or SBC, activates. SBC Speed is used with SS1 and SQS-SS1 safety functions. When you use the value 0 for SBC Speed, and a non-zero value for Zero Speed, Zero Speed is used instead as the condition for the first safety function to activate. See the tables in 6.2.2.3 The STO Function Used with the SBC Function .

Parameter	Selection	Unit	Description
			If this parameter is used when the SS1 function or the SQS-SS1 function is used in the time monitoring mode, the value of the parameter is an alternative triggering point for the STO(+SBC) function in addition to the normal activation after the time set with SS1 t1.

8.5 SS1 Parameters

Table 72: SS1 Parameters

Parameter	Selection	Unit	Description
Acknowledgment Mode (SS1)	Manual Automatic	–	Use this parameter to select if manual (external) acknowledgment is necessary to deactivate the safety function after the request ends. If the selection is automatic , the function is deactivated after the request ends.
SS1 Monitoring	Time. Time + Zero Speed. Time + Zero Speed + Ramp.	–	Use this parameter to select the monitoring mode for the safety function.
SS1 Ramp Monitoring	Digital input/PLCs Ramp 1 Ramp 2	–	Use this parameter to select the source for the ramp that is monitored if ramp monitoring is used.
SS1 t1	0...3 000 000	ms	Use this parameter to set the time after which the STO function activates (when only time monitoring is used), or after which the SS1 function must be reached (when zero speed monitoring is used).
SS1 td1	20...65535	ms	Use this parameter to set the time after the activation of the function during which the ramp monitoring must start (when ramp monitoring is used).
SS1 td2	0...65535	ms	Use this parameter to set the time delay for the activation of the STO+SBC function after speed goes below zero speed (when zero speed monitoring is used).

8.6 SS2 and SOS Parameters

Table 73: SS2 and SOS Parameters

Parameter	Selection	Unit	Description
Acknowledgment Mode (SS2)	Manual Automatic	–	Use this parameter to select if manual (external) acknowledgment is necessary to deactivate the safety function after the request ends. If the selection is automatic, the function is deactivated after the request ends.
SS2 Monitoring	Time. Time + Zero Speed. Time + Zero Speed + Ramp.	–	Use this parameter to select the monitoring mode for the safety function.
SS2 Ramp Monitoring	Digital input /PLC Ramp 1 Ramp 2	–	Use this parameter to select the source for the ramp that is monitored if ramp monitoring is used.
SS2 t1	0...3 000 000	ms	Use this parameter to set the time after which the SOS function activates (when only time monitoring is used), or after which the SS2 function must be reached (when zero speed monitoring is used).

Parameter	Selection	Unit	Description
SS2 td1	20...65535	ms	Use this parameter to set the time after the activation of the function during which the ramp monitoring must start (when ramp monitoring is used).
SS2 td2	0...65535	ms	Use this parameter to set the time delay for the activation of the SOS function after speed goes below zero speed (when zero speed monitoring is used).
SOS Revolution Limit	0.01...100.00	revolutions	Use this parameter to set the allowed deviation from the initial position after the SOS function has started.

8.7 SQS Parameters

Table 74: SQS Parameters

Parameter	Selection	Unit	Description
Acknowledgment Mode (SQS)	Manual Automatic	–	Use this parameter to select if manual (external) acknowledgment is necessary to deactivate the safety function after the request ends. If the selection is automatic , the function is deactivated after the request ends.
SQS Type	STO SS1 SS2	–	Use this parameter to set the behavior of the SQS function.

Table 75: The Parameters for SQS-SS1 and SQS-SS2

Parameter	Selection	Unit	Description
SQS Monitoring	Time. Time + Zero Speed. Time + Zero Speed + Ramp.		Use this parameter to select if zero speed monitoring and ramp monitoring are used for the SQS-SS1 or the SQS-SS2 function.
SQS t1	0...3 000 000	ms	Use this parameter to set the time after which the STO or the SOS function activates (when only time monitoring is used), or after which the SQS function must be reached (when zero speed monitoring is used).
SQS td1	20...65535	ms	Use this parameter to set the time after the activation of the function during which the ramp monitoring must start (when ramp monitoring is used).
SQS td2	0...65535	ms	Use this parameter to set the time delay for the activation of the STO+SBC or the SOS function after speed goes below zero speed (when zero speed monitoring is used).
SQS Ramp Speed	0...65535	rpm	Use this parameter to set the nominal speed used to define the SQS ramp.
SQS Ramp Dec Time Min	0...3 000 000	ms	Use this parameter to set the minimum time for the speed to decelerate from SQS Ramp Speed to zero.
SQS Ramp Dec Time Max	0...3 000 000	ms	Use this parameter to set the maximum time for the speed to decelerate from SQS Ramp Speed to zero.

8.8 SLS Parameters

Table 76: SLS Parameters

Parameter	Selection	Unit	Description
Acknowledgment Mode (SLS)	Manual Automatic	–	Use this parameter to select if manual (external) acknowledgment is necessary to deactivate the safety function after the request ends. If the selection is automatic, the function is deactivated after the request ends.
SLS Ramp Monitoring	None Ramp 1 Ramp 2	–	Use this parameter to select the ramp that is monitored.
SLS t1	0...3 000 000	ms	Use this parameter to set the time after which the SLS function must be reached. This parameter is used in these conditions: <ul style="list-style-type: none"> When the SLS function is activated. When the SLS limit is changed to lower limit. For example from 500 rpm (SLS 2) to 300 rpm (SLS 1).
SLS td1	20...65535	ms	Use this parameter to set the time after the activation of the function during which the ramp monitoring must start (when ramp monitoring is used).
SLS td2	0...65535	ms	Use this parameter to set the time during which the speed must stay below the selected SLS limit speed before the function becomes reached.
SLS td3	0...255	ms	Use this parameter to set the transition time that is permitted for the two SLS inputs to reach the selected value before the new value of the request is evaluated. The first change starts the time.
SLS 1 Limit	0...65535	rpm	Use this parameter to set the monitored speed limit for SLS 1 Limit. Setting the value to 0 does not disable the monitoring.
SLS 2 Limit	0...65535	rpm	Use this parameter to set the monitored speed limit for SLS 2 Limit. Setting the value to 0 does not disable the monitoring.
SLS 3 Limit	0...65535	rpm	Use this parameter to set the monitored speed limit for SLS 3 Limit. Setting the value to 0 does not disable the monitoring.

8.9 SMS Parameters

Table 77: SMS Parameters

Parameter	Selection	Unit	Description
Acknowledgment Mode (SMS)	Manual Automatic	–	Use this parameter to select if manual (external) acknowledgment is necessary to deactivate the safety function after the request ends. If the selection is automatic , the function is deactivated after the request ends.
SMS Limit Plus	0...65535	rpm	Use this parameter to set the monitored maximum speed limit to positive direction when the SMS function is active.
SMS Limit Minus	-65535...0	rpm	Use this parameter to set the monitored maximum speed limit to negative direction when the SMS function is active.

8.10 SSR Parameters

Table 78: SSR Parameters

Parameter	Selection	Unit	Description
Acknowledgment Mode (SSR)	Manual Automatic	–	Use this parameter to select if manual (external) acknowledgment is necessary to deactivate the safety function after the request ends. If the selection is automatic , the function is deactivated after the request ends.
SSR Ramp Monitoring	None Ramp 1 Ramp 2	–	Use this parameter to select the monitored ramp.
SSR t1	0...3 000 000	ms	Use this parameter to set the time after which the SSR function must be reached.
SSR td1	20...65535	ms	Use this parameter to set the time after the activation of the function during which the ramp monitoring must start (when ramp monitoring used).
SSR td2	0...65535	ms	Use this parameter to set the time during which the speed must stay below the SSR limit speed before the function becomes reached.
SSR Max Limit	0...65535	rpm	Use this parameter to set the monitored maximum speed limit that is used when the SSR function is active. Setting the value to 0 disables the monitoring of the maximum limit.
SSR Min Limit	0...65535	rpm	Use this parameter to set the monitored minimum speed limit that is used when the SSR function is active. Setting the value to 0 disables the monitoring of the minimum limit.

8.11 SSM Parameters

Table 79: SSM Parameters

Parameter	Selection	Unit	Description
Acknowledgment Mode (SSM)	Manual Automatic	–	Use this parameter to select if manual (external) acknowledgment is necessary to deactivate the safety function after the request ends. If the selection is automatic, the function is deactivated after the request ends. NOTE! This parameter is valid only when the SSM function is not set to always active.
Always Active	Active Inactive	–	Use this parameter to set the SSM function to be always active. A checkbox selection. NOTE! When the SSM function is set to always active, it is not possible to assign an input for it or request it over a safe fieldbus.
SSM td2	0...65535	ms	Use this parameter to set the time during which the speed must stay within the monitored limits before the function becomes reached.
SSM Max Limit	0...65535	rpm	Use this parameter to set the monitored maximum speed limit that is used when the SSM function is active. NOTE! Setting the value to 0 disables the monitoring of the maximum limit.
SSM Min Limit	0...65535	rpm	Use this parameter to set the monitored minimum speed limit that is used when the SSM function is active. NOTE! Setting the value to 0 disables the monitoring of the minimum limit.

8.12 Validation Parameters

Table 80: Validation Parameters

Parameter	Selection	Unit	Description
Tester name	A maximum of 32 ASCII characters.	–	Use this parameter to write the name of the validator of the system.
Company	A maximum of 32 ASCII characters.	–	Use this parameter to write the name of the employer of the validator.
Date	–	–	Use this parameter to write the date when the system was validated.
Comment	A maximum of 120 ASCII characters.	–	Use this parameter to write a description of the validation, for example, relevant versions of the subsystems.

9 Commissioning and Validation

9.1 Preparing for Commissioning

9.1.1 Preparing for Commissioning

The information in this chapter is also included in the Commissioning report.

The Commissioning report lists relevant instructions for commissioning the option board. The Commissioning report can be printed from the VACON[®]Safe tool with prefilled data or downloaded from the Danfoss website.

If it is possible, commission the AC drive first without the Advanced safety option board to make sure that your process is operational.

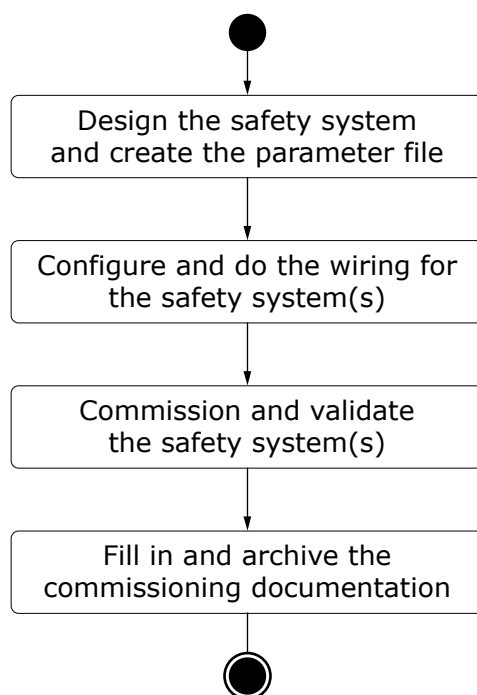

e30bi404.10

Illustration 72: Preparing and Commissioning a Safety System that Includes the Advanced Safety Option Board

9.1.2 Procedures Before the First Start-up of the System with the Option

Procedure

1. Read carefully the warnings in chapter Safety.
2. Read the Advanced safety option board Operating Guide and the Commissioning report and apply their instructions in the commissioning plan.
3. Read the operating guide of the AC drive.
4. Refer to the user guide of other subsystems connected to the commissioned drive system.
5. Define the parameter file for the Advanced safety option board.
6. Make sure that the hardware and configuration are correct, and that the software is correct in the components of the AC drive and its subsystems.
7. Make sure that the information of the commissioned AC drive matches the information in the commissioning plan and the Commissioning report.
8. Make sure that the connections between different systems have been checked and are ready to be used.
9. Make sure that the area affected by the commissioned systems is free and secure for the commissioning.
10. Make sure that no danger can be caused to personnel if the system has been configured incorrectly and behaves unexpectedly.
11. Make sure that the AC drive is correctly parameterized and commissioned for use.
 - a. The motor parameters have been set.
 - b. The identification run has been done. Preferred identification type: identification with run or encoder ID run.
 - c. The fieldbus connection can be established. If a fieldbus is used.

12. Have a computer available with software to control and parameterize the AC drive and the option boards, and to store test logs and parameters.
13. Have the Commissioning report available.
14. Document the deviations compared to expected results during the commissioning and testing procedures. Do not release the system for use if any unacceptable deviations exist.

9.1.3 Preparing for Commissioning Checklist

Table 81: Preparing for Commissioning Checklist

Step	Description	Yes	No
1	Has a risk assessment of the system been done to make sure that the usage of the option board is safe and according to the local regulations?		
2	Does the risk assessment include an examination of whether using external devices such as a mechanical brake is required?		
3	Have the external components been selected according to the required safety performance target (SIL or PL)?		
4	Have the process requirements (for example, ramp times, speed limits, and violation responses) been considered for a correct execution of safety functions and are the corresponding settings done to all relevant systems?		
5	Have the instructions of all the components used in the system been read?		
6	Has the system been designed so that no component or procedure can unexpectedly cause it to restart?		
7	Has the system been designed so that it cannot be unexpectedly locked in to a non-clearable state? For example, the fault reset conditions for all systems can be reached when a fault reset is necessary.		
8	Have routines been set up for regularly checking the functionality of the safety functions?		
9	Have routines been set up for reporting problems?		

9.2 Doing the First Start-up After the Installation of the Option Board

The information in this chapter is also included in the Commissioning report. After the option board is installed in the AC drive, do these steps.

Procedure

1. Power up the AC drive.
 - a. The drive shows the fault F38 DeviceAdded (example: slot D, subcode 1 if Advanced safety option is installed in slot D). The actual faults shown depend on the configuration used during the previous start-up if other changes have also been made.
 - b. If the option board was already installed and tested at the factory, the fault is not shown.
 - c. Other faults are also shown: the warning for Safe Torque Off (F30, subcode: 1) and the fault for Safety System (F20 SafetySystem, source: 82 - Plaus. check, fault number: 3). Fault F20 indicates that the option board has no valid parameter file.
 - d. The option board also does diagnostic selftests. If other F20 SafetySystem faults are shown, see chapter Fault tracing.
2. Reset the faults.
 - a. The drive is not ready. The warning F30 SafeTorqueOff is shown.
 - b. If the option board has been used in a previous configuration, it is possible that it has a valid parameter file already. In this case, the drive may be in READY state.
 - c. The faults that are shown and their type (Fault or Alarm) depend on the settings of the AC drive.
 - d. STO state can also be seen from the STO board diagnostic relay output.
3. Parameterize the option board using the VACON^{AE} Safe tool.
 - a. After parameterization the fault F20 (source: 82, fault number: 3) no longer appears. Depending on the parameterized safety functions and the state of the option board inputs, different safety functions can be reported as requested or reached.

- b. The fault F20 (source: 243 - drive conf, fault number: 2) appears. The fault indicates that the parameter file is not tested and validated.
- 4. Print the prefilled Commissioning report from the VACON®Safe tool or save the report in digital form.
- 5. Commission the safety functions using the commissioning report.

9.2.1 Commissioning Check List

Table 82: Commissioning Check List

Step	Commissioning action	Yes	No
1	The correct installation of the option board has been verified and documented.		
2	The option board has been parameterized with the intended configuration.		

To commission the different safety functions, see the Commissioning report of the option board.

9.3 Validating the Parameter File

The information in this chapter is also included in the Commissioning report. After the commissioning of the system with the option board, validate the parameter file stored in the option board.

Procedure

1. Select "Validate" in the VACON®Safe tool.
2. Fill in the validation data.
3. Save the validation data to the option board.
4. Reboot the AC drive.
 - a. The warning on a not validated parameter file disappears.
5. Make sure that the Commissioning report is filled correctly and archive it.

9.4 Checklist before Taking the System into Use

The system can be taken into use after these conditions are fulfilled:

- The AC drive is parameterized and commissioned.
- The commissioning of the option board is completed.
 - The option board is parameterized.
 - The used safety functions and features have been tested.
 - The parameter file of the option board is validated.
- Other related subsystems have been correctly commissioned.
- Other safety-related systems that were modified or disabled for the commissioning are enabled or returned to the normal operation mode.

9.5 Bypassing Safety Features

! D A N G E R !

BYPASS HAZARD

When the Advanced safety option board is bypassed, it does not provide any safety functions.

- Consider carefully before bypassing the Advanced safety option board.

N O T I C E

While not strictly required, it is recommended to return the parameter P7.4.1.2.1 to its default value "Default" after the commissioning activities.

If the Advanced safety option board is installed in the AC drive with an STO board and the AC drive itself has not been commissioned, it may be preferable to bypass the safety functions of the Advanced safety option to make the commissioning simpler. To bypass the safety functions of the Advanced safety option, do these steps.

Procedure

1. Disconnect the STO outputs of the Advanced safety option board if they are connected. Leave the outputs disconnected.
2. Connect the STO request input of the STO board to terminals +24 V and GND so that the STO function is disabled.
3. Power up the AC drive.
4. Set the parameter P7.4.1.2.1 in the expander board menu to value "Warning" to deactivate the drive response to faults reported by the Advanced safety option.
5. Reset the faults.
 - a. The AC drive should be in the READY state.

10 Operation and Maintenance

10.1 Gathering Diagnostic Data

When additional information on the option board is necessary, you can use these sources of information.

- You can monitor certain values using the monitoring or datalogger tools of the AC drive and the PC software.
- The drive info and the used parameter file can be downloaded from the AC drive. Newer versions of the tools of the AC drive can download all relevant information when downloading service info. Old tools download only the drive info, and you must download the parameter file manually with the VACON^{AE}Safe tool.
- The option board saves the states of the relevant internal values when changes to these values occur. This activity log can be downloaded with the VACON^{AE}Safe tool.
- You can use the control panel or the PC tools of the AC drive to browse parameter and monitoring values.

When you contact the manufacturer for support, provide at least the service info of the AC drive including the parameter file. If the support request is related to the behavior of the AC drive or the option board in certain situations, also provide the datalogger, the monitoring log, or the option board activity log.

The hardware revision is printed on the main board of the option board.

The firmware version of the option board can be found in 2 ways.

Finding the firmware version of the option board:

- Use the VACON^{AE}Safe tool. Connect to the drive in question. Select the symbol "?" and then select "About". The tool shows the firmware version of the option board and the version of the PC tool.
- Use the control panel of the AC drive.

See chapter [3.8.3 Option Board Menu on the Control Panel](#).

Table below lists the Advanced safety option specific values that should be considered for logging when submitting support request for Danfoss support. The needed signals depend on the situation that is being monitored.

Table 83: Internal Variables of the Drive for Monitoring and Logging

Variable	Source/ type	Description
SafetyEncoder-Speed	Firmware	The speed measured by Advanced safety option from encoder and proximity sensor. Unit: rpm When using multiple sensors (e.g. two proximity sensors) this value displays the average of the speed measured from the two sensors.
SafetyFunctionRequestWordDIN SafetyFunctionRequestWordPLC	Firmware	Displays the state of the request for safety functions from digital input (DIN) or over PROFIsafe (PLC). 0 = The safety function is not requested. 1 = The safety function is requested. B0 = STO B1 = SS1 B2 = SS2 B3 = SQS B4 = SSR B5 = SLS1 B6 = SLS2 B7 = SLS3 B10 = SSM B11 = SMS
SafetyFunction-StatusWord	Firmware	Displays the state of the safety functions. Corresponds to the Active signal of the safety function. 0 = The safety function is not active. 1 = The safety function is active. B0 = STO

Variable	Source/ type	Description
		B1 = SS1 B2 = SS2 B3 = SQS B4 = SSR B5 = SLS1 B6 = SLS2 B7 = SLS3 B10 = SSM B11 = SMS
SafetyFunction-ReachedWord	Firmware	Displays the reached status of the safety functions. Corresponds to the Reached signal of the safety function. 0 = The safety function is not reached. 1 = The safety function is reached. B0 = STO B1 = SS1 B2 = SS2 B3 = SQS B4 = SSR B5 = SLS1 B6 = SLS2 B7 = SLS3 B10 = SSM B11 = SMS
SafetyGeneralStatusWord	Firmware	Displays various states of the Advanced safety option. NOTE! The state is updated only for digital inputs and outputs that have a functionality assigned to them. Bits corresponding to unused digital inputs and outputs remain as "0" regardless of the actual state. B0 = DIN1 B1 = DIN2 B2 = DIN3 B3 = DIN4 B4 = DOUT1 B5 = DOUT2 B6 = SSM_Above_Max_Limit B7 = SSM_Below_Max_Limit B8 = Acknowledge_Requested_DIN B9 = Acknowledge_Requested_PLC B10 = Acknowledge_Requested_Drive B11 = SS1_Ramp_Select B12 = SS2_Ramp_Select B13 = Reset_Requested_DIN B14 = Reset_Requested_PLC B15 = Reset_Requested_Drive
EstimatedShaft-Frequency	Firmware	Displays the value of the estimated speed provided to the Advanced safety option.
EstimatedShaft-FreqInvalid	Firmware	If this value is other than 0, the Estimated Shaft Frequency is not currently being calculated and provided to the Advanced safety option.

If there is room, also add other signals related to the logged situation to the monitoring. They can help to link the Advanced safety option signals to the drive state and external system events.

10.2 Periodic Testing

The option board does self-tests to determine the correct operation of its subsystems. If faults are found, they are reported to the user.

If certain inputs or outputs of the option board are not used during normal operation despite having safety functions assigned to them, a test should be executed periodically to make sure there are no problems related to the cabling.

- For inputs, it is sufficient to deactivate the input to request the assigned safety function and verify that the safety function activates. The activation can be verified, for example, from a warning activation in the drive or safe fieldbus reporting the activation of the safety function.
- For outputs, the conditions for deactivating and/or activating the output should be fulfilled and external system or equipment should be used to verify the change in the signal state.

For systems with speed measurement and long standstill time, see [3.6.6 Encoder Signal Verification](#).

When the motor is at standstill for long periods of time, for example because the STO or the SOS state is maintained in the AC drive, pay attention to the test intervals.

When the SBC safety function is used, the brake system should be periodically checked for correct operation.

Outside the need for encoder rotation during a long standstill, the Advanced safety option board does not require any periodic tests or maintenance. The necessity for testing is determined by the application. When you plan the periodic tests, obey the regulations and standards, and take into account the risk and hazard analysis for the application and its safety components.

See the recommendation on periodic testing of the European coordination of Notified Bodies for Machinery (CNB/M/11.050) for two-channel safety systems with electromechanical outputs in [Table 84](#). The Advanced safety option board itself does not contain any electromechanical outputs.

Table 84: Recommended Periodic Testing for Components with Electromechanical Outputs

System safety level	Testing interval
SIL3 with HFT 1 (EN IEC 62061) PLe, Category 3 or Category 4 (EN ISO 13849-1)	One month
SIL2 with HFT 1 (EN IEC 62061) PLd, Category 3 (EN ISO 13849-1)	One year

10.3 Resetting the Password

You can reset the passwords used to parameterize the Advanced safety option board from the control panel of the AC drive. Use the parameter P7.4.1.1.1 to start the password reset. Slot D used as an example in the parameter address (P7.4.1.1.1) is different in other slots. See [3.8.3 Option Board Menu on the Control Panel](#). The password reset only resets the passwords on the option board. There are no other effects. The password reset is included in the factory reset (P7.4.1.1.2).

Procedure

1. Navigate to the parameter P7.4.1.1.1 Password reset under the menu group G7.4.1.1 Config Settings.
2. Set the value Reset to the parameter P7.4.1.1.1.
3. If necessary, set new passwords using the VACON[®]Safe tool.

10.4 Factory Reset

Factory reset of the Advanced safety option board is not connected to the factory reset of the AC drive. The factory reset of the AC drive does not do a factory reset to the Advanced safety option board, and the factory reset of the Advanced safety option board does not affect other drive components. The factory reset of the option board can be done from the control panel of the AC drive. Use the parameter P7.4.1.1.2 to start the factory reset. Slot D used as an example in the parameter address (P7.4.1.1.2) is different in other slots. See [3.8.3 Option Board Menu on the Control Panel](#).

The effects of the factory reset:

- The parameter file of the option board is deleted. The STO function stays active until the option board is parameterized again.
- The passwords are reset to the default value.
- The activity log in the option board is cleared.

Procedure

1. Navigate to the parameter P7.4.1.1.2 Factory Reset under menu group G7.4.1.1 Config Settings.

2. Set the value Reset to the parameter P7.4.1.1.2.
3. Make sure that the factory reset was done. These signs show that it was done:

- The STO function is active.
- The fault F20 (F20 SafetySystem, source: 82 - Plaus. check, fault number: 3) appears.

4. Parameterize the option board again or store it according to the storing conditions.

10.5 Software Update

The firmware of the Advanced safety option board can be updated to add new features or to fix errors.

N O T I C E

Always make sure that you use the latest or correct revision of the manual when assessing the behavior of the Advanced safety option board. See [1.3 Manual and Software Version](#).

When updating the firmware:

- Find out if the new version offers additional features that are necessary in the system, and if there are faults in the current version that have an effect on the system.
- Depending on the changes, it may be that other systems connected to the option board will also require new versions or modifications to account for the changed behavior of the option board. These can include the components of the AC drive and the external systems.
- Changing the firmware of the option board can have an effect on the behavior of the overall safety system. Consider the need for a revalidation of the whole system before you update any software.
- Due to changes in the safety functions, it is possible that the parameter file of an old firmware version is not compatible with the new firmware version. Creation of a new parameter file for the option board can be necessary after an update.

N O T I C E

The firmware can be updated only via the panel connector of the AC drive.

To update the firmware of the option board, use these tools and data:

- The cable and other equipment for connecting a PC to the AC drive.
- The updated firmware file.
- The VACON® Loader for updating the firmware on the option board.
- The VACON® Safe tool for reading and saving the parameter file.

N O T I C E

The update of the option board firmware is not protected by a password. To control unwanted changes, the parameter file in the option board will be deleted in the firmware update. After the update, you must parameterize the option board again.

10.5.1 Updating the Firmware

Procedure

1. Prepare the necessary equipment and data.
2. Store the sealed parameter file, for example, on the control board of the AC drive or on your PC. The parameter file in the option board will be deleted in the firmware update.
3. Do the firmware update using the VACON® Loader.
4. Make sure that the firmware version for the option board is the intended version. See [10.1 Gathering Diagnostic Data](#).
5. Find the stored parameter file and save it back to the option board.
6. Validate the safety system again.

10.6 Replacing the Option Board

⚠ WARNING ⚠

SHOCK HAZARD FROM CONTROL TERMINALS

The control terminals can have a dangerous voltage also when the drive is disconnected from mains. A contact with this voltage can lead to injury.

- Make sure that there is no voltage in the control terminals before touching the control terminals.

⚠ CAUTION ⚠

DAMAGE TO OPTION BOARDS

Do not install, remove, or replace option boards on the drive when the power is on. Doing this can cause damage to the boards.

- Switch off the AC drive before installing, removing, or replacing option boards on the drive.

⚠ CAUTION ⚠

FAULTY OPTION BOARD

Indications of a faulty option board can be, for example, constant faults that indicate internal faults of the option board. Even if the option board works correctly some of the time, there can be underlying faults that can create unexpected situations and cause damage to the equipment.

- Replace an option board when it is suspected to be faulty.

⚠ CAUTION ⚠

REPAIRING THE OPTION BOARD

Unsuccessful repair work can cause damage to the equipment. Return faulty option boards to the manufacturer for analysis.

- Do not perform any repair work on the option board.

Find out if your software and parameter file version are supported by the new hardware version.

Parameterize the new option board. It can be necessary to load the existing parameter file from the current option board.

Changing the option board can affect the operation of whole safety system. It can be necessary to revalidate the safety system. Changes may be due to different hardware versions or faults in either the old or new option board.

Procedure

1. Store the parameter file of the option board, for example, on the control board of the AC drive or on your PC.

If the old option board is intended to be used in another system or as a back-up, you can delete its parameter file using factory reset. See [10.4 Factory Reset](#).

2. Disconnect power, including the power stage supply voltage and the controller supply.
3. Make sure that there is no voltage.
4. Remove the old option board.
5. Install the new option board using the instructions in [4.1 Installation Safety](#) and [4.2 Installing the Option Board](#).
6. Commission the new option board.
7. Keep the replaced option board for further use, or contact Danfoss for possible analysis of the option board. Also see [10.8 Disposal](#).

➡ After replacing the option board, the next start-up is the first start-up of the new option board. Do the checks and procedures of the first start-up. See [9.1.2 Procedures Before the First Start-up of the System with the Option](#) and [9.1.3 Preparing for Commissioning Checklist](#).

10.7 Replacement of Other Components of the Safety System

When you plan and make changes to other components of the safety system where the Advanced safety option board is included, consider the possible effects of the changes.

After you have made changes in the systems that request safety functions or react to output data from the option board (via safe fieldbus or digital output), the safety system should always be revalidated. Refer to the instructions of the changed component(s) and [9.3 Validating the Parameter File](#).

The level of testing that is adequate after a component has been changed depends on the application. The tests mentioned in this chapter do not take into account the overall system and application. A reduced validation of the system may or may not be possible. When in doubt, consider a total recommissioning of the related features.

Table 85: Tests after Changing the Drive Related Components

Component	Tests
The hardware of the control board	Retest the STO safety function. If estimated speed is used, retest the safe monitoring functions.
The software of the control board	Retest features that have relations in the control board. These can be related, for example, to the realization of safety function limits or the safe fieldbus. If estimated speed is used, retest the safe monitoring functions.
The drive application	Retest safety functions that have relations in the drive application. These can be, for example, execution of controlled stop ramps for the SS1, SS2, or SQS safety functions or realization of a speed limit for a safe monitoring function.
The power unit of the drive	Retest the STO safety function. If estimated speed is used, retest the safe monitoring functions.
Other option boards	Retest safety features that have relation to that option board. Example safe fieldbus when changing a fieldbus related option board. When you change the STO option board, retest the STO safety function.
Speed sensors	Check the speed sensor settings in the parameter file. Retest speed-dependent safety functions.

10.8 Disposal

When the drive is at the end of its operation life, do not discard it as a part of municipal waste. Recycle the primary components of the drive. You must disassemble some components before the different materials can be removed. Recycle the electrical and electronic components as waste. To make sure that the waste is recycled correctly, send the waste to a recycling center. The waste can also be sent back to the manufacturer. Obey the local and other applicable regulations.

If the option board is decommissioned or disposed due to a suspected failure of the option board, contact the manufacturer to report the incident and to ask if it is necessary to return the option board to the manufacturer for further analysis.



11 Technical Data

11.1 Safety Data

Table 86: General Safety Characteristics

Item	Value
Safety integrity level (SIL) (IEC 61508)	up to SIL3
Systematic capability (SC) (IEC 61508)	SIL3
Safety integrity level claim limit (SIL CL) (EN 62061)	SILCL3
Performance level (PL) (EN ISO 13849-1: 2015)	up to PLe
Category (Cat) (EN ISO 13849-1: 2015)	Cat 4
Hardware Fault Tolerance (HFT)	1 (1oo2)
Proof test interval (PTI)	20 years ⁽¹⁾
Mission time / Lifetime (TM)	20 years

¹ PTI is Mission time/lifetime. No proof test for the option board required during the lifetime.

When you use standard speed sensors, see [3.6.2 Standard Speed Sensors and Combinations](#).

Table 87: Detailed Safety Characteristics

Option board variant ⁽¹⁾	PFH _d [1/h]	PFD _{avg}	DC _{avg} [%]	MTTF _d [a]	SFF [%]
OPTBL	6.45 x 10 ⁻¹¹	5.61 x 10 ⁻⁶	99	373	99
OPTBM	1.66 x 10 ⁻⁹	1.45 x 10 ⁻⁴		112	
OPTBN	1.70 x 10 ⁻⁹	1.49 x 10 ⁻⁴		94	

¹ All the values in the table are worst case values for one safety function and are fulfilled in any valid configuration.

The values above are calculated with these assumptions:

- MTTR = MTR = 0 h. When a failure is detected, the STO safety function becomes active.
- The proof test interval is 20 years.

Table 88: Response Times

Technical item or function	Minimum	Typical	Maximum
Response time to safety function request	–	–	10 ms
Response time to violation of a safety function	–	–	– ⁽¹⁾

¹ The response time to a violation depends on these factors:

- Pulse per rotation (PPR) of the speed measurement sensor. The response time is faster with a higher PPR value.
- Actual speed at the time of the violation of the monitored speed limit. The response time is faster in higher speeds.

11.2 Safe Input/Output Data

Number of inputs: 4 logical (4x2 physical).

Table 89: Safe Input Data

Technical item or function	Minimum	Typical	Maximum
Input Voltage (Active, logic 1)	–	24 V	30 V
Input Voltage (Inactive, logic 0)	-3 V	0 V	5 V
Input Current (Active, logic 1)	3.0 mA	–	5.5 mA
Input Current (Inactive, logic 0)	–	–	2.0 mA
Input Resistance	3 kΩ	–	–
Galvanic Isolation	No		
Short circuit protected	Yes		
Active -> Inactive Debounce time	4 ms		
Inactive -> Active Debounce time	50 ms		
Allowed discrepancy time of physical inputs in one logical input	–	–	500 ms
Conductor size/cross-section (AWG)	0.2 mm ² (28)		1 mm ² (18)

Number of outputs (general): 2 logical (2x2 physical).

Number of outputs (STO): 2 logical (2 physical).

Table 90: Safe Output Data

Technical item or function	Minimum	Typical	Maximum
Output Voltage (Active, logic 1)	17 V	24 V	27 V
Output Voltage (Inactive, logic 0)	–	0 V	5 V
Output Current (Active, logic 1)	–	–	100 mA (250 mA combined ⁽¹⁾)
Output Current (Inactive, logic 0)	–	–	0.1 mA
Galvanic Isolation	No		
Short-circuit protected	Yes		
Diagnostic test pulsing	Alternating between a simultaneous pulse and individual pulse sequences on each physical output. Delay of 10 ms between pulses.		
Diagnostic test pulse length	–	200 μs	400 μs
Diagnostic test sequence interval	–	200 ms	–
Output channel discrepancy time	–	–	–
Conductor size/cross-section (AWG)	0.2 mm ² (28)	–	1 mm ² (18)
Output state in case of a fault	All outputs are inactive.		

¹ Combined maximum output current for the Digital Output (STO & normal) and 24V supply is 250 mA.

Table 91: 24 V Supply Output

Technical item or function	Minimum	Typical	Maximum
Supply voltage	–	24 V ± 15%	–
Output current	–	–	150 mA (250 mA combined ⁽¹⁾)
Short-circuit protected	Yes		

¹ Combined maximum output current for the Digital Output (STO & normal) and 24V supply is 250 mA.

11.3 Speed Measurement Data

Table 92: Multiple Speed Source Cross-comparison

Technical item or function	Minimum	Typical	Maximum
Allowed deviation between speed sources (encoder/proximity sensor/ estimated speed)	Set with parameter Allowed Deviation of Estimated Speed.		
Allowed time for exceeding the allowed speed deviation	Set with parameter Allowed Deviation Timer.		

Table 93: Sin/Cos

Technical item or function	Minimum	Typical	Maximum
Encoder Supply Voltage	5 V, 12 V, 15 V, 24 V. ± 5%		
Encoder Supply Current	–	–	150 mA
Operating Sin/Cos waveform	1 Vpp ± 25% with +2.5 VDC offset		
Operating phase-shift Sin/Cos	$\sin^2 x + \cos^2 x = 1 \pm 40\%$		
Operating Frequency	–	–	250 kHz
Termination resistor	200 Ω		
Cable length	See recommendation of encoder manufacturer.		
Conductor size/cross-section (AWG)	0.14 mm ² (26)		0.5 mm ² (20)

Table 94: Digital Pulse

Technical item or function	Minimum	Typical	Maximum
Encoder Supply Voltage HTL	5 V, 12 V, 15 V, 24 V. ± 5%		
Encoder Supply Voltage TTL	5 V, 12 V, 15 V, 24 V. ± 5%		
Encoder Supply Current	–	–	150 mA
Connection TTL	According to RS-422 interface standard		
Supported HTL signals	Differential ⁽¹⁾		
HTL Voltage output type	Push-Pull		
Differential Input Voltage HTL(Active, logic 1) VA→Ā	2 V	–	30 V
Differential Input Voltage HTL(Inactive, logic 0) VA→Ā	-30 V	–	-2 V
Operating phase-shift A/B	–	–	90° ± 20%

Technical item or function	Minimum	Typical	Maximum
Operating Frequency	–	–	350 kHz
Pulse length for signal Z	1/4*T ≈ 0.7 us	–	–
Termination resistor	200 Ω if used, cannot be used with HTL encoder.		
Cable length	See recommendation of encoder manufacturer.		
Conductor size/cross-section (AWG)	0.14 mm ² (26)	–	0.5 mm ² (20)

¹ Single-ended encoders or single-ended encoder connections are not supported.

Proximity sensors connected to Digital input 1 and 2 of the safe I/O. Also see technical data for inputs.

Table 95: Proximity Sensors

Technical item or function	Minimum	Typical	Maximum
Supported types	4-wire PNP		
Duty cycle (Signal ACTIVE-INAC- TIVE ratio)	1%	50% (1:1 ratio)	99%
Operating Frequency	–	–	10 kHz (50% dutycycle) 0.2 kHz (1% or 99% duty cycle)
Pulse length	50 μs	–	–
Recommended value for the safety function speed limit (see 3.6.5 Proximity sensors)	15000/ppr	–	–

Table 96: Estimated Speed

Technical item or function	Minimum	Typical	Maximum
Supported motor types	Asynchronous motor (ASM), also known as induction motor (IM). Synchronous motor (SM), which typically is permanent magnet synchronous motor (PMSM).		
Supported speed range	0 Hz	–	Approximately 200% of the motor nominal speed, or 320 Hz.
Estimation error	–	ASM: < 50% of nominal slip. ⁽¹⁾ SM: Estimated speed = actual speed.	ASM: Approximately ± 50% of nominal slip. ⁽¹⁾
Speed estimation active	Speed estimation is active only when the AC drive is in RUN state.		

¹ With an asynchronous motor, the estimation is typically less reliable at low speeds and more reliable at high speeds.

The effects of external accelerative forces are not taken into account in the values above. The values are valid in these conditions:

- The motor parameters have been set correctly, and the motor identification run has been completed successfully.
- The motor is not overloaded.

11.4 Safe Fieldbus Data

Table 97: Safe Fieldbus Data

Technical item or function	Minimum	Typical	Maximum
Safe fieldbus state in case of critical error	No communication		
Supported protocols	PROFIsafe over PROFIBUS/PROFINET		
Supported PROFIdrive on PROFIsafe telegrams	ST30, ST31, ST58000		

11.5 Environmental Data

Table 98: Environmental Data

Technical item or function	Minimum	Typical	Maximum
Ambient operating temperature	According to the used AC drive.		
Storing ambient temperature	-40°C	–	+80°C
Air Humidity	According to the used AC drive. Non-condensing.		
Operating altitude	According to the used AC drive.		

12 Fault Tracing

12.1 Presentation of Faults on the Control Board

Faults with the fault code F20 have a special syntax when they are shown on the control panel or the PC tools. Instead of the usually included "module" and "submodule" fields, fields "source" and "source (text)" are used. These fields identify the source of the fault on the Advanced safety option board. Source (text) is a textual explanation of the source value. The fault number field identifies the detailed cause of the fault.

The figures show an example of the fault presentation of the Advanced safety option board on the control panel.

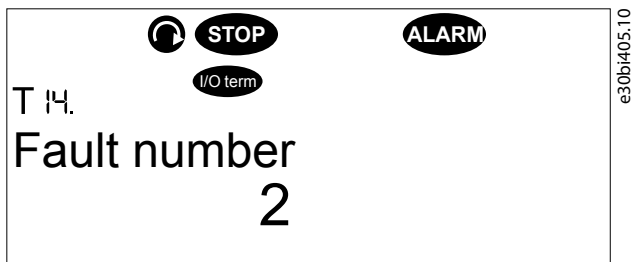

Illustration 73: The Fault Number Is Shown in T.14 (instead of "Subcode" for Other Faults)

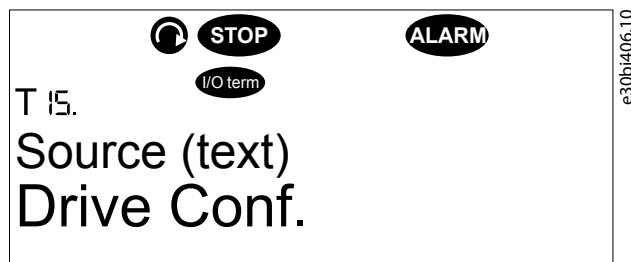

Illustration 74: The Description of the Source Is Shown in T.15 (instead of "Module" for Other Faults)

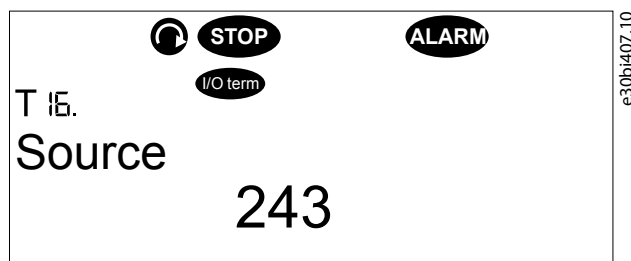

Illustration 75: The Source Value Is Shown in T.16 (instead of "Submodule" for Other Faults)

Additionally, the source and fault number are shown in the fault lists (active faults and fault history) when you view faults related to the Advanced safety option board.



Illustration 76: Fault Presentation in the Fault Lists. The Source and Fault Number Are Shown as "source.number" (instead of "T1->T16" for Other Faults).

The safety function violation faults (Fault code F48) use the same syntax as the fault code 20. The source fields indicate the safety function that was violated. The number field indicates the violation that has occurred.

NOTICE

Some faults may have additional information that is not saved in the fault system of the AC drive. The complete information can be seen in the option board activity log, see [5.6.2 Activity Log](#).

12.2 Fault Codes

12.2.1 Fault Code 20 - Safety System, S1 - uC diag., Fault Number Any

Cause

- Internal fault in the option board.
- Broken hardware.

Troubleshooting

- Reboot the AC drive.
- If the fault reoccurs, contact the nearest distributor.

12.2.2 Fault Code 20 - Safety System, S2 - Cross comm., Fault Number Any

Cause

- Internal fault in the option board.
- Broken hardware.
- Incompatible software and/or hardware versions or a failed update.

Troubleshooting

- Reboot the AC drive.
- If the fault reoccurs, contact the nearest distributor.

12.2.3 Fault Code 20 - Safety System, S3 - Input stuck, Fault Number Any

Cause

- Internal fault in the option board.
- Broken hardware.

Troubleshooting

- Reboot the AC drive.
- If the fault reoccurs, contact the nearest distributor.

12.2.4 Fault Code 20 - Safety System, S4 - Output Stuck, Fault Number 1

Cause

- An output is short-circuited to voltage source (for example, +24 V).

Troubleshooting

- Check the cabling.

12.2.5 Fault Code 20 - Safety System, S4 - Output Stuck, Fault Number 2

Cause

- There is a fault in an output of the Advanced safety option board.
- The STO output of the Advanced safety option board is not connected.

Troubleshooting

- Check the cabling.

12.2.6 Fault Code 20 - Safety System, S4 - Output Stuck, Fault Number 3

Cause

- An output is short-circuited to GND.

Troubleshooting

- Check the cabling.

12.2.7 Fault Code 20 - Safety System, S4 - Output Stuck, Fault Number 4

Cause

- An output is short-circuited to voltage source (for example, +24 V).

Troubleshooting

- Check the cabling.

12.2.8 Fault Code 20 - Safety System, S6 - Power Supply, Fault Number Any

Cause

- Internal fault in the option board.
- Broken hardware.

Troubleshooting

- Reboot the AC drive.
- If the fault reoccurs, contact the nearest distributor.

12.2.9 Fault Code 20 - Safety System, S6 - Power Supply, Fault Number 9

Cause

- Encoder supply voltage overvoltage or undervoltage.

Troubleshooting

- Check the cabling for short circuits.
- Make sure that the encoder cable plug at the Advanced safety option board is inserted correctly (not off by one).

12.2.10 Fault Code 20 - Safety System, S6 - Power Supply, Fault Number 25

Cause

- Encoder supply voltage overvoltage or undervoltage.

Troubleshooting

- Check the cabling for short circuits.
- Make sure that the encoder cable plug at the Advanced safety option board is inserted correctly (not off by one).

12.2.11 Fault Code 20 - Safety System, S10 - Cross Check, Fault Number 1, 2

Cause

- Internal fault in the option board.
- Broken hardware.

Troubleshooting

- Reboot the AC drive.
- If the fault reoccurs, contact the nearest distributor.

12.2.12 Fault Code 20 - Safety System, S10 - Cross Check, Fault Number 3

Cause

- Incompatible software and/or hardware versions or a failed update.

Troubleshooting

- Update the option board firmware.
- If the fault reoccurs, contact the nearest distributor.

12.2.13 Fault Code 20 - Safety System, S12 - General, Fault Number Any

Cause

- Internal fault in the option board.

Troubleshooting

- Reboot the AC drive.
- If the fault reoccurs, contact the nearest distributor.

12.2.14 Fault Code 20 - Safety System, S17 - Comm. Error, Fault Number Any

Cause

- Incompatible control and option board firmware.

Troubleshooting

- Reboot the AC drive.
- Update the control and/or option board firmware.
- If the fault reoccurs, contact the nearest distributor.

12.2.15 Fault Code 20 - Safety System, S18 - External I/O, Fault Number 1

Cause

- Channels of a two channel input are in different state.

Troubleshooting

- Check the cabling.
- Check the connected systems.
- Reboot the AC drive.

12.2.16 Fault Code 20 - Safety System, S18 - External I/O, Fault Number 2

Cause

- One channel caused a short request (input inactive) for a safety function before returning to not requested state (input active). The other channel did not change.

Troubleshooting

- Check the cabling.
- Check the connected systems.
- Deactivate both channels before activating them again, then acknowledge the safety function.

12.2.17 Fault Code 20 - Safety System, S32 - SafeF Common, Fault Number 3

Cause

- The reset signal has not been accepted because a safe stopping function executed as a violation response has not been reached.

Troubleshooting

- Allow the safe stopping function to finish its execution.

12.2.18 Fault Code 20 - Safety System, S32 - SafeF Common, Fault Number 4

Cause

- The reset signal cannot be accepted as the speed is above a monitoring limit at requested monitoring function.

Troubleshooting

- Check the requested safety functions.
- Check the motor speed and the speed sensors.

12.2.19 Fault Code 20 - Safety System, S32 - SafeF Common, Fault Number 5

Cause

- The reset signal cannot be accepted as the speed is above a monitoring limit at requested monitoring function.

Troubleshooting

- Check the requested safety functions.
- Check the motor speed and the speed sensors.

12.2.20 Fault Code 20 - Safety System, S33 – STO, Fault Number 1

Cause

- The safety function is controlled from the PLC over fieldbus but the requested safety function is not parameterized to be used at all.

Troubleshooting

- Make sure that the configurations of the PLC and the Advanced safety option board match.

12.2.21 Fault Code 20 - Safety System, S33 – STO, Fault Number 2, 3

Cause

- The reset/acknowledgment signal cannot be accepted because the STO safety function is requested or the motor is rotating.

Troubleshooting

- Wait until the motor stops.
- Check the encoder.

12.2.22 Fault Code 20 - Safety System, S34 – SS1, Fault Number 1

Cause

- The safety function is controlled from the PLC over fieldbus but the requested safety function is not parameterized to be used at all.

Troubleshooting

- Make sure that the configurations of the PLC and the Advanced safety option board match.

12.2.23 Fault Code 20 - Safety System, S34 – SS1, Fault Number 5

Cause

- An acknowledgment signal was received when the safety function was still requested and could not be acknowledged.

Troubleshooting

- Deactivate the safety function request before acknowledging.

12.2.24 Fault Code 20 - Safety System, S35 – SS2, Fault Number 1

Cause

- The safety function is controlled from the PLC over fieldbus but the requested safety function is not parameterized to be used at all.

Troubleshooting

- Make sure that the configurations of the PLC and the Advanced safety option board match.

12.2.25 Fault Code 20 - Safety System, S35 – SS2, Fault Number 5

Cause

- An acknowledgment signal was received when the safety function was still requested and could not be acknowledged.

Troubleshooting

- Deactivate the safety function request before acknowledging.

12.2.26 Fault Code 20 - Safety System, S38 – SQS, Fault Number 1

Cause

- The safety function is controlled from the PLC over fieldbus but the requested safety function is not parameterized to be used at all.

Troubleshooting

- Make sure that the configurations of the PLC and the Advanced safety option board match.

12.2.27 Fault Code 20 - Safety System, S38 – SQS, Fault Number 5

Cause

- An acknowledgment signal was received when the safety function was still requested and could not be acknowledged.

Troubleshooting

- Deactivate the safety function request before acknowledging.

12.2.28 Fault Code 20 - Safety System, S39 – SSR, Fault Number 1

Cause

- The safety function is controlled from the PLC over fieldbus but the requested safety function is not parameterized to be used at all.

Troubleshooting

- Make sure that the configurations of the PLC and the Advanced safety option board match.

12.2.29 Fault Code 20 - Safety System, S39 – SSR, Fault Number 9

Cause

- An acknowledgment signal was received when the safety function was still requested and could not be acknowledged.

Troubleshooting

- Deactivate the safety function request before acknowledging.

12.2.30 Fault Code 20 - Safety System, S40 – SLS, Fault Number 1

Cause

- The safety function is controlled from the PLC over fieldbus but the requested safety function is not parameterized to be used at all.

Troubleshooting

- Make sure that the configurations of the PLC and the Advanced safety option board match.

12.2.31 Fault Code 20 - Safety System, S40 – SLS, Fault Number 8

Cause

- An acknowledgment signal was received when the safety function was still requested and could not be acknowledged.

Troubleshooting

- Deactivate the safety function request before acknowledging.

12.2.32 Fault Code 20 - Safety System, S43 – SMS, Fault Number 1

Cause

- The safety function is controlled from the PLC over fieldbus but the requested safety function is not parameterized to be used at all.

Troubleshooting

- Make sure that the configurations of the PLC and the Advanced safety option board match.

12.2.33 Fault Code 20 - Safety System, S43 – SMS, Fault Number 4

Cause

- An acknowledgment signal was received when the safety function was still requested and could not be acknowledged.

Troubleshooting

- Deactivate the safety function request before acknowledging.

12.2.34 Fault Code 20 - Safety System, S44 – SSM, Fault Number 2

Cause

- An acknowledgment signal was received when the safety function was still requested and could not be acknowledged.

Troubleshooting

- Deactivate the safety function request before acknowledging.

12.2.35 Fault Code 20 - Safety System, S48 – Enc. Common, Fault Number 1, 13

Cause

- An internal fault in the encoder interface board.

Troubleshooting

- Reboot the AC drive.
- If the fault reoccurs, contact the nearest distributor.

12.2.36 Fault Code 20 - Safety System, S48 – Enc. Common, Fault Number 4–8

Cause

- A fault detected in the encoder signal monitoring.
- There is excessive ripple in a signal channel.
- A wrong phase shift between signals.

Troubleshooting

- Check the encoder connections.
- Check the encoder.

12.2.37 Fault Code 20 - Safety System, S48 – Enc. Common, Fault Number 9

Cause

- Reference pulse from the encoder is missing or detected too often.

Troubleshooting

- Check the encoder cabling.
- Check the parameters.

12.2.38 Fault Code 20 - Safety System, S48 – Enc. Common, Fault Number 11

Cause

- A parameterization fault in the encoder.

Troubleshooting

- Check the parameters.

12.2.39 Fault Code 20 - Safety System, S48 – Enc. Common, Fault Number 12

Cause

- The supported operating frequency of the encoder signals was exceeded.

Troubleshooting

- See the technical data for the used encoder type or information on the maximum frequency.

12.2.40 Fault Code 20 - Safety System, S48 – Enc. Common, Fault Number 14

Cause

- The types of the parameterized and the actual encoder interface board do not match.

Troubleshooting

- Check the parameters.
- Check the type of the encoder interface board.

12.2.41 Fault Code 20 - Safety System, S48 – Enc. Common, Fault Number 15

Cause

- When you use two speed measurement sources: the sources indicate different speeds for the motor.

Troubleshooting

- Check the speed sensor parameters.
- Check the speed sensors.

12.2.42 Fault Code 20 - Safety System, S48 – Enc. Common, Fault Number 18

Cause

- Proof test interval was exceeded. The motor has not been rotated during a 30 day period.

Troubleshooting

- Make the motor rotate according to the instructions in [3.6.6 Encoder Signal Verification](#).

12.2.43 Fault Code 20 - Safety System, S48 – Enc. Common, Fault Number Other

Cause

- Faults related to the encoder.
- A wrong phase shift between signals.
- Discrepancy between different speed sources is too high.

Troubleshooting

- Check the encoder connections.
- Check the encoder parameters.
- Check the encoder.
- Reboot the AC drive.
- If the fault reoccurs, contact the nearest distributor.

12.2.44 Fault Code 20 - Safety System, S49 – Sin-Cos enc., Fault Number 1–3

Cause

- A fault detected in the encoder signal monitoring. Example: the signals do not fulfill the equation $\sin^2x + \cos^2x = 1$.

Troubleshooting

- Check the encoder connections.
- Check the encoder.

12.2.45 Fault Code 20 - Safety System, S49 - Sin-Cos Enc., Fault Number Other

Cause

- Faults related to the encoder.
- A wrong phase shift between signals.
- Discrepancy between different speed sources is too high.

Troubleshooting

- Check the encoder connections.
- Check the encoder parameters.
- Check the encoder.

- Reboot the AC drive.
- If the fault reoccurs, contact the nearest distributor.

12.2.46 Fault Code 20 - Safety System, S52 – Increm. enc., Fault Number 1

Cause

- A problem with encoder signal A.

Troubleshooting

- Check the encoder cabling.

12.2.47 Fault Code 20 - Safety System, S52 – Increm. enc., Fault Number 2

Cause

- A problem with encoder signal B.
- Certain encoders can intentionally drive all their inputs to low during start-up or after the detection of a failure.

Troubleshooting

- Check the encoder cabling.
- Check if the used encoder can force the signals to an invalid state to indicate a fault.

12.2.48 Fault Code 20 - Safety System, S52 – Increm. enc., Fault Number 3

Cause

- A problem with encoder reference signal.

Troubleshooting

- Check the encoder cabling.

12.2.49 Fault Code 20 - Safety System, S52 - Increm. Enc., Fault Number Other

Cause

- Faults related to the encoder.
- A wrong phase shift between signals.
- Discrepancy between different speed sources is too high.

Troubleshooting

- Check the encoder connections.
- Check the encoder parameters.
- Check the encoder.
- Reboot the AC drive.
- If the fault reoccurs, contact the nearest distributor.

12.2.50 Fault Code 20 - Safety System, S53 – Prox. sensor, Fault Number 2

Cause

- A short circuit between the signals of the proximity sensor 1.

Troubleshooting

- Check the proximity sensor cabling.

12.2.51 Fault Code 20 - Safety System, S53 – Prox. sensor, Fault Number 3

Cause

- A short circuit between the signals of the proximity sensor 2.

Troubleshooting

- Check the proximity sensor cabling.

12.2.52 Fault Code 20 - Safety System, S53 – Prox. sensor, Fault Number 4

Cause

- When two proximity sensors are used: the signals of the proximity sensor have a different frequency.

Troubleshooting

- Check the proximity sensors.

12.2.53 Fault Code 20 - Safety System, S53 – Prox. sensor, Fault Number 5

Cause

- The supported operating frequency for the proximity sensor 1 was exceeded.

Troubleshooting

- Check the parameters.
- Check the proximity sensor.

12.2.54 Fault Code 20 - Safety System, S53 – Prox. sensor, Fault Number 6

Cause

- The supported operating frequency for the proximity sensor 2 was exceeded.

Troubleshooting

- Check the parameters.
- Check the proximity sensor.

12.2.55 Fault Code 20 - Safety System, S53 - Prox. Sensor, Fault Number Other

Cause

- Faults related to the encoder.
- A wrong phase shift between signals.
- Discrepancy between different speed sources is too high.

Troubleshooting

- Check the encoder connections.
- Check the encoder parameters.
- Check the encoder.
- Reboot the AC drive.
- If the fault reoccurs, contact the nearest distributor.

12.2.56 Fault Code 20 - Safety System, S54 – Estimated Sp, Fault Number 1

Cause

- Estimated speed difference exceeded (Allowed Deviation of Speed Sources, Speed Deviation Timer).
- The rotation direction of the estimated speed and the encoder are opposite.

Troubleshooting

- Check the encoder and estimated speed parameters.
- Check the cabling (motor phases and encoder signals) to make sure that it does not cause one of the directions to reverse.

12.2.57 Fault Code 20 - Safety System, S65 - PROFIsafe, Fault Number 4

Cause

- The PROFIsafe telegram is commanding the drive to a fail-safe state.
- The watchdog time was exceeded.

Troubleshooting

- Check the F-parameters in the option board and the safety PLC.

12.2.58 Fault Code 20 - Safety System, S65 - PROFIsafe, Fault Number 5

Cause

- The PROFIsafe telegram is commanding the AC drive to a failsafe state.

Troubleshooting

- Acknowledge the situation in PLC.

12.2.59 Fault Code 20 - Safety System, S65 - PROFIsafe, Fault Number Other

Cause

- Fault in the communication between the option board and the external safe fieldbus master.
- Interference.

Troubleshooting

- Check the fieldbus parameters in option boards and PLC.
- Check the cabling.

12.2.60 Fault Code 20 - Safety System, S67 - F-Parameter, Fault Number 64

Cause

- The F Destination Address does not match.

Troubleshooting

- Check the F-parameters in the option board and the safety PLC.

12.2.61 Fault Code 20 - Safety System, S67 - F-Parameter, Fault Number 65

Cause

- The F Destination Address is outside the valid range.

Troubleshooting

- Check the F-parameters in the option board and the safety PLC.

12.2.62 Fault Code 20 - Safety System, S67 - F-Parameter, Fault Number 66

Cause

- The F Source Address does not match.

Troubleshooting

- Check the F-parameters in the option board and the safety PLC.

12.2.63 Fault Code 20 - Safety System, S67 - F-Parameter, Fault Number 67

Cause

- The Watchdog time F WD Time is 0 or invalid.

Troubleshooting

- Check the F-parameters in the option board and the safety PLC.

12.2.64 Fault Code 20 - Safety System, S67 - F-Parameter, Fault Number 69

Cause

- The length of the F parameter CRC does not match.

Troubleshooting

- Check the F-parameters in the option board and the safety PLC.

12.2.65 Fault Code 20 - Safety System, S67 - F-Parameter, Fault Number 70

Cause

- The F parameter version is incorrect.

Troubleshooting

- Check the F-parameters in the option board and the safety PLC.

12.2.66 Fault Code 20 - Safety System, S67 - F-Parameter, Fault Number 71

Cause

- The F parameter CRC does not match.

Troubleshooting

- Check the F-parameters in the option board and the safety PLC.

12.2.67 Fault Code 20 - Safety System, S67 - F-Parameter, Fault Number 75

Cause

- The device specific parameter CRC (iParameter CRC) does not match.

Troubleshooting

- Check the F-parameters in the option board and the safety PLC.

12.2.68 Fault Code 20 - Safety System, S67 - F-Parameter, Fault Number Other

Cause

- Fault in the communication between the option board and the external safe fieldbus master.
- Interference.

Troubleshooting

- Check the fieldbus parameters in option boards and PLC.
- Check the cabling.

12.2.69 Fault Code 20 - Safety System, S68 - PROFIdrive, Fault Number 1

Cause

- Invalid or unsupported data in the control word.
- A wrong telegram used.

Troubleshooting

- Check the programming of the safety PLC.
- Check the parameters.

12.2.70 Fault Code 20 - Safety System, S68 - PROFIdrive, Fault Number Other

Cause

- Fault in the communication between the option board and the external safe fieldbus master.
- Interference.

Troubleshooting

- Check the fieldbus parameters in option boards and PLC.
- Check the cabling.

12.2.71 Fault Code 20 - Safety System, S80 - HiLevel Comm, Fault Number Any

Cause

- Fault in the communication.
- Incompatible version of the PC tool.
- Interference.

Troubleshooting

- Check the used cables and equipment.
- Reboot the AC drive.
- If the fault reoccurs, contact the distributor near you.

12.2.72 Fault Code 20 - Safety System, S81 - Comm Timeout, Fault Number 3

Cause

- Valid F-Parameters from safety PLC have not been received.

Troubleshooting

- Check the parameter settings of the safety PLC and of the used fieldbus board.
- Make sure that normal fieldbus communication is established.

12.2.73 Fault Code 20 - Safety System, S81 - Comm Timeout, Fault Number Other

Cause

- Fault in the communication.
- Incompatible version of the PC tool.
- Interference.

Troubleshooting

- Check the used cables and equipment.
- Reboot the AC drive.
- If the fault reoccurs, contact the distributor near you.

12.2.74 Fault Code 20 - Safety System, S82 - Plaus. Check, Fault Number 3

Cause

- There is no valid parameter file in the option board.

Troubleshooting

- Save new parameter file from PC or back-up.

12.2.75 Fault Code 20 - Safety System, S82 - Plaus. Check, Fault Number Other

Cause

- Fault in the safety configuration.
- There are invalid parameters.

Troubleshooting

- Check the used parameter file.

12.2.76 Fault Code 20 - Safety System, S83 - CB Comm., Fault Number Any

Cause

- Fault in the communication.
- Incompatible version of the PC tool.
- Interference.

Troubleshooting

- Check the used cables and equipment.
- Reboot the AC drive.
- If the fault reoccurs, contact the distributor near you.

12.2.77 Fault Code 20 - Safety System, S84 - Gateway Comm, Fault Number 1

Cause

- The F-parameters are invalid.

Troubleshooting

- Check the safe fieldbus parameters.
- Check the safety PLC configuration.

12.2.78 Fault Code 20 - Safety System, S84 - Gateway Comm, Fault Number 2

Cause

- The safety telegram number is invalid.

Troubleshooting

- Check the safe fieldbus parameters.
- Check the safety PLC configuration.

12.2.79 Fault Code 20 - Safety System, S84 - Gateway Comm, Fault Number Other

Cause

- Fault in the communication between the option board and the external safe fieldbus master.
- Interference.

Troubleshooting

- Check the fieldbus parameters in option boards and PLC.
- Check the cabling.

12.2.80 Fault Code 20 - Safety System, S85 - PC General, Fault Number Other

Cause

- Fault in the communication between the option board and the PC tool.

Troubleshooting

- Check the used cables and equipment.
- Retry the attempted operation.

12.2.81 Fault Code 20 - Safety System, S86 - Activity Log, Fault Number Other

Cause

- A fault in the internal logging.

Troubleshooting

- Reboot the AC drive.
- If the fault reoccurs, contact the distributor near you.

12.2.82 Fault Code 20 - Safety System, S241 - CB Internal, Fault Number Any

Cause

- An internal fault.
- An incompatible firmware.
- The communication between the control board and the option board was interrupted.

Troubleshooting

- Reboot the AC drive.
- Update the option board and/or control board firmware.
- If the fault reoccurs, contact the distributor near you.

12.2.83 Fault Code 20 - Safety System, S242 - CB Internal, Fault Number Any

Cause

- An internal fault.
- An incompatible firmware.
- The communication between the control board and the option board was interrupted.

Troubleshooting

- Reboot the AC drive.
- Update the option board and/or control board firmware.
- If the fault reoccurs, contact the distributor near you.

12.2.84 Fault Code 20 - Safety System, S243 - Drive Conf., Fault Number 2

Cause

- The parameter file used in the option board is not validated.

Troubleshooting

- Commission and test the system configuration and validate parameter file.

12.2.85 Fault Code 20 - Safety System, S243 - Drive Conf., Fault Number 33

Cause

- Restoring a parameter file back-up to the option board failed.

Troubleshooting

- Reboot the AC drive.
- Make sure that there is a valid back-up to be restored.

12.2.86 Fault Code 20 - Safety System, S243 - Drive Conf., Fault Number 34

Cause

- Transferring of the parameter file from the option board to the control board failed.

Troubleshooting

- Reboot the AC drive.

12.2.87 Fault Code 20 - Safety System, S243 - Drive Conf., Fault Number 35

Cause

- The AC drive received the F-parameters but no safe fieldbus communication is set.

Troubleshooting

- Check the F-parameters in the option board and the safety PLC.

12.2.88 Fault Code 20 - Safety System, S243 - Drive Conf., Fault Number 80

Cause

- Communication with VACON[®]Safe was lost.

Troubleshooting

- Check the cabling.

12.2.89 Fault Code 8 - System Fault, S83 - Board Not Present

Cause

The safe fieldbus communication is activated in the fieldbus board but the Advanced safety option board is missing.

Troubleshooting

Remove the safe fieldbus module from the fieldbus board communication in the PLC, or install the Advanced safety option board.

12.2.90 Fault Code 8 - System Fault, S84 - Incompatible Gateway

Cause

The safe fieldbus communication is enabled in the Advanced safety option board but the used standard fieldbus board does not support it.

Troubleshooting

- Check the configuration of the option board.
- Check the firmware of the fieldbus board.
- Check that the correct type of fieldbus option board is used.

12.2.91 Fault Code 8 - System Fault, S85 - Startup Failed

Cause

- The Advanced safety option board is detected but does not communicate with the control board.
- The Advanced safety option board is broken.

Troubleshooting

- Reboot the AC drive.
- Update the option board firmware.
- If the fault reoccurs, contact the local distributor.

12.2.92 Fault Code 46 - Safety Request, S1 - STO

Cause

- This warning is an indication that a safety function is active on the AC drive.

Troubleshooting

- If the parameter Acknowledgment Mode (Startup) is set to manual, the STO function is indicated as requested after startup until an acknowledgment is received.
- As a default, faults with the code 46 or 47 are not saved into the fault history of the AC drive. The drive application can change the logging mode so that these faults are saved in the fault history. The Activity log can be used to see the activation and deactivation history of the safety functions.

12.2.93 Fault Code 46 - Safety Request, S2 - SS1

Cause

- This warning is an indication that a safety function is active on the AC drive.

Troubleshooting

- As a default, faults with the code 46 or 47 are not saved into the fault history of the AC drive. The drive application can change the logging mode so that these faults are saved in the fault history. The Activity log can be used to see the activation and deactivation history of the safety functions.

12.2.94 Fault Code 46 - Safety Request, S3 - SS2

Cause

- This warning is an indication that a safety function is active on the AC drive.

Troubleshooting

- As a default, faults with the code 46 or 47 are not saved into the fault history of the AC drive. The drive application can change the logging mode so that these faults are saved in the fault history. The Activity log can be used to see the activation and deactivation history of the safety functions.

12.2.95 Fault Code 46 - Safety Request, S4 - SQS

Cause

- This warning is an indication that a safety function is active on the AC drive.

Troubleshooting

- As a default, faults with the code 46 or 47 are not saved into the fault history of the AC drive. The drive application can change the logging mode so that these faults are saved in the fault history. The Activity log can be used to see the activation and deactivation history of the safety functions.

12.2.96 Fault Code 46 - Safety Request, S5 - SSR

Cause

- This warning is an indication that a safety function is active on the AC drive.

Troubleshooting

- As a default, faults with the code 46 or 47 are not saved into the fault history of the AC drive. The drive application can change the logging mode so that these faults are saved in the fault history. The Activity log can be used to see the activation and deactivation history of the safety functions.

12.2.97 Fault Code 46 - Safety Request, S6 - SLS 1

Cause

- This warning is an indication that a safety function is active on the AC drive.

Troubleshooting

- As a default, faults with the code 46 or 47 are not saved into the fault history of the AC drive. The drive application can change the logging mode so that these faults are saved in the fault history. The Activity log can be used to see the activation and deactivation history of the safety functions.

12.2.98 Fault Code 46 - Safety Request, S7 - SLS 2

Cause

- This warning is an indication that a safety function is active on the AC drive.

Troubleshooting

- As a default, faults with the code 46 or 47 are not saved into the fault history of the AC drive. The drive application can change the logging mode so that these faults are saved in the fault history. The Activity log can be used to see the activation and deactivation history of the safety functions.

12.2.99 Fault Code 46 - Safety Request, S8 - SLS 3

Cause

- This warning is an indication that a safety function is active on the AC drive.

Troubleshooting

- As a default, faults with the code 46 or 47 are not saved into the fault history of the AC drive. The drive application can change the logging mode so that these faults are saved in the fault history. The Activity log can be used to see the activation and deactivation history of the safety functions.

12.2.100 Fault Code 46 - Safety Request, S11 - SSM

Cause

- This warning is an indication that a safety function is active on the AC drive.

Troubleshooting

- As a default, faults with the code 46 or 47 are not saved into the fault history of the AC drive. The drive application can change the logging mode so that these faults are saved in the fault history. The Activity log can be used to see the activation and deactivation history of the safety functions.

12.2.101 Fault Code 46 - Safety Request, S12 - SMS

Cause

- This warning is an indication that a safety function is active on the AC drive.

Troubleshooting

- As a default, faults with the code 46 or 47 are not saved into the fault history of the AC drive. The drive application can change the logging mode so that these faults are saved in the fault history. The Activity log can be used to see the activation and deactivation history of the safety functions.

12.2.102 Fault Code 47 - Safety Reached, S1 - STO

Cause

- This warning is an indication that a safety function is in the Reached state.

Troubleshooting

- For the safe stopping functions, the possible controlled stop has been executed and the STO(+SBC) or the SOS function is active.
- As a default, faults with the code 46 or 47 are not saved into the fault history of the AC drive. The drive application can change the logging mode so that these faults are saved in the fault history. The Activity log can be used to see the activation and deactivation history of the safety functions.

12.2.103 Fault Code 47 - Safety Reached, S2 - SS1

Cause

- This warning is an indication that a safety function is in the Reached state.

Troubleshooting

- For the safe stopping functions, the possible controlled stop has been executed and the STO(+SBC) or the SOS function is active.
- As a default, faults with the code 46 or 47 are not saved into the fault history of the AC drive. The drive application can change the logging mode so that these faults are saved in the fault history. The Activity log can be used to see the activation and deactivation history of the safety functions.

12.2.104 Fault Code 47 - Safety Reached, S3 - SS2

Cause

- This warning is an indication that a safety function is in the Reached state.

Troubleshooting

- For the safe stopping functions, the possible controlled stop has been executed and the STO(+SBC) or the SOS function is active.
- As a default, faults with the code 46 or 47 are not saved into the fault history of the AC drive. The drive application can change the logging mode so that these faults are saved in the fault history. The Activity log can be used to see the activation and deactivation history of the safety functions.

12.2.105 Fault Code 47 - Safety Reached, S4 - SQS

Cause

- This warning is an indication that a safety function is in the Reached state.

Troubleshooting

- For the safe stopping functions, the possible controlled stop has been executed and the STO(+SBC) or the SOS function is active.
- As a default, faults with the code 46 or 47 are not saved into the fault history of the AC drive. The drive application can change the logging mode so that these faults are saved in the fault history. The Activity log can be used to see the activation and deactivation history of the safety functions.

12.2.106 Fault Code 47 - Safety Reached, S5 - SSR

Cause

- This warning is an indication that a safety function is in the Reached state.

Troubleshooting

- For the safe monitoring functions, the related limit is being monitored.
- As a default, faults with the code 46 or 47 are not saved into the fault history of the AC drive. The drive application can change the logging mode so that these faults are saved in the fault history. The Activity log can be used to see the activation and deactivation history of the safety functions.

12.2.107 Fault Code 47 - Safety Reached, S6 - SLS 1

Cause

- This warning is an indication that a safety function is in the Reached state.

Troubleshooting

- For the safe monitoring functions, the related limit is being monitored.
- As a default, faults with the code 46 or 47 are not saved into the fault history of the AC drive. The drive application can change the logging mode so that these faults are saved in the fault history. The Activity log can be used to see the activation and deactivation history of the safety functions.

12.2.108 Fault Code 47 - Safety Reached, S7 - SLS 2

Cause

- This warning is an indication that a safety function is in the Reached state.

Troubleshooting

- For the safe monitoring functions, the related limit is being monitored.
- As a default, faults with the code 46 or 47 are not saved into the fault history of the AC drive. The drive application can change the logging mode so that these faults are saved in the fault history. The Activity log can be used to see the activation and deactivation history of the safety functions.

12.2.109 Fault Code 47 - Safety Reached, S8 - SLS 3

Cause

- This warning is an indication that a safety function is in the Reached state.

Troubleshooting

- For the safe monitoring functions, the related limit is being monitored.
- As a default, faults with the code 46 or 47 are not saved into the fault history of the AC drive. The drive application can change the logging mode so that these faults are saved in the fault history. The Activity log can be used to see the activation and deactivation history of the safety functions.

12.2.110 Fault Code 47 - Safety Reached, S11 - SSM

Cause

- This warning is an indication that a safety function is in the Reached state.

Troubleshooting

- For the safe monitoring functions, the related limit is being monitored.
- As a default, faults with the code 46 or 47 are not saved into the fault history of the AC drive. The drive application can change the logging mode so that these faults are saved in the fault history. The Activity log can be used to see the activation and deactivation history of the safety functions.

12.2.111 Fault Code 47 - Safety Reached, S12 - SMS

Cause

- This warning is an indication that a safety function is in the Reached state.

Troubleshooting

- For the safe monitoring functions, the related limit is being monitored.
- As a default, faults with the code 46 or 47 are not saved into the fault history of the AC drive. The drive application can change the logging mode so that these faults are saved in the fault history. The Activity log can be used to see the activation and deactivation history of the safety functions.

12.2.112 Fault Code 48 - Safety Violation, S31 - SOS, Fault Number 1

Cause

- The deviation from the starting point was greater than allowed during the SOS function.

Troubleshooting

- -

12.2.113 Fault Code 48 - Safety Violation, S34 - SS1, Fault Number 2

Cause

- Only when zero speed monitoring is used: the time set with t1 of the safety function has passed but the function is not reached.

Troubleshooting

- -

12.2.114 Fault Code 48 - Safety Violation, S34 - SS1, Fault Number 3

Cause

- The motor speed exceeds the maximum deceleration ramp (Ramp1_Dec_Time_Max)

Troubleshooting

- -

12.2.115 Fault Code 48 - Safety Violation, S34 - SS1, Fault Number 4

Cause

- The motor speed exceeds the minimum deceleration ramp (Ramp1_Dec_Time_Min)

Troubleshooting

- -

12.2.116 Fault Code 48 - Safety Violation, S35 - SS2, Fault Number 2

Cause

- Only when zero speed monitoring is used: the time set with t1 of the safety function has passed but the function is not reached.

Troubleshooting

- -

12.2.117 Fault Code 48 - Safety Violation, S35 - SS2, Fault Number 3

Cause

- The motor speed exceeds the maximum deceleration ramp (Ramp1_Dec_Time_Max)

Troubleshooting

- -

12.2.118 Fault Code 48 - Safety Violation, S35 - SS2, Fault Number 4

Cause

- The motor speed exceeds the minimum deceleration ramp (Ramp1_Dec_Time_Min)

Troubleshooting

- -

12.2.119 Fault Code 48 - Safety Violation, S38 - SQS, Fault Number 2

Cause

- Only when zero speed monitoring is used: the time set with t1 of the safety function has passed but the function is not reached.

Troubleshooting

- -

12.2.120 Fault Code 48 - Safety Violation, S38 - SQS, Fault Number 3

Cause

- The motor speed exceeds the maximum deceleration ramp (Ramp1_Dec_Time_Max)

Troubleshooting

- -

12.2.121 Fault Code 48 - Safety Violation, S38 - SQS, Fault Number 4

Cause

- The motor speed exceeds the minimum deceleration ramp (Ramp1_Dec_Time_Min)

Troubleshooting

- -

12.2.122 Fault Code 48 - Safety Violation, S39 - SSR, Fault Number 2

Cause

- The maximum deceleration ramp was violated.

Troubleshooting

- -

12.2.123 Fault Code 48 - Safety Violation, S39 - SSR, Fault Number 3

Cause

- The minimum deceleration ramp was violated.

Troubleshooting

- -

12.2.124 Fault Code 48 - Safety Violation, S39 - SSR, Fault Number 4

Cause

- The maximum acceleration ramp was violated.

Troubleshooting

- -

12.2.125 Fault Code 48 - Safety Violation, S39 - SSR, Fault Number 5

Cause

- The minimum acceleration ramp was violated.

Troubleshooting

- -

12.2.126 Fault Code 48 - Safety Violation, S39 - SSR, Fault Number 6

Cause

- The function was not reached when the time set with SSR t1 passed.

Troubleshooting

- -

12.2.127 Fault Code 48 - Safety Violation, S39 - SSR, Fault Number 7

Cause

- The maximum speed limit was violated.

Troubleshooting

- -

12.2.128 Fault Code 48 - Safety Violation, S39 - SSR, Fault Number 8

Cause

- The minimum speed limit was violated.

Troubleshooting

- -

12.2.129 Fault Code 48 - Safety Violation, S40 - SLS, Fault Number 2

Cause

- Only when zero speed monitoring is used: the time set with t1 of the safety function has passed but the function is not reached.

Troubleshooting

- -

12.2.130 Fault Code 48 - Safety Violation, S40 - SLS, Fault Number 3

Cause

- The motor speed exceeds the maximum deceleration ramp (Ramp1_Dec_Time_Max)

Troubleshooting

- -

12.2.131 Fault Code 48 - Safety Violation, S40 - SLS, Fault Number 4

Cause

- The motor speed exceeds the minimum deceleration ramp (Ramp1_Dec_Time_Min)

Troubleshooting

- -

12.2.132 Fault Code 48 - Safety Violation, S40 - SLS, Fault Number 5

Cause

- SLS 1 Limit was violated.

Troubleshooting

- -

12.2.133 Fault Code 48 - Safety Violation, S40 - SLS, Fault Number 6

Cause

- SLS 2 Limit was violated.

Troubleshooting

- -

12.2.134 Fault Code 48 - Safety Violation, S40 - SLS, Fault Number 7

Cause

- SLS 3 Limit was violated.

Troubleshooting

- -

12.2.135 Fault Code 48 - Safety Violation, S43 - SMS, Fault Number 2

Cause

- SMS Limit Plus was violated.

Troubleshooting

- -

12.2.136 Fault Code 48 - Safety Violation, S43 - SMS, Fault Number 3

Cause

- SMS Limit Minus was violated.

Troubleshooting

- -

12.3 OPTAF STO and ATEX Option Board Fault Information

In certain situations, the OPTAF option board can detect faults that are due to the Advanced safety option or indicate an error in the configuration of the system. See the VACON[®]NX OPTAF STO Board Manual for description on these faults and how to correct them.

NOTICE

With OPTAF, the reaction to STO activation can be selected as fault level. Do not use the fault level reaction with the Advanced safety option. Doing so can lead to situations where two fault reset commands are needed for the STO fault triggered by OPTAF to be cleared. For further information, see the relevant parameter description in the VACON[®]NX OPTAF STO Board Manual.

13 Configuration Examples

13.1 General Information

This chapter lists configuration examples of the Advanced safety option board for implementing different safety functions.

The examples are informational and do not guarantee the achievement of any safety levels. The examples show different possibilities to use the option board. The examples do not take into account the external devices and their exact behavior. To implement an actual safety system, it is necessary to make proper preparations and analysis on the requirements of the safety system and to have an understanding on all the devices that are used in the implementation. Also see [3.4 Determining the Achieved Safety Level](#).

13.2 Emergency Stop Using the STO Function

This is an example configuration for realizing emergency stop according to IEC-60204-1 using the STO function in the Advanced safety option board OPTBL and the STO option board OPTAF. The drive reset is used to clear the faults and to deactivate the STO function after violations and faults. The STO function is set to the manual acknowledgment mode.

Depending on the result of the risk and hazard analysis, you can use the safe external acknowledgment signal 1) or the non-safe drive acknowledgment 2). The case in [Illustration 77](#) has safe external acknowledgment.

The STO request is assigned to Digital Input 1 of the Advanced safety option board. External acknowledgment signal is assigned to Digital input 2. No speed measurement is needed or considered for this configuration.

Table 99: Configuration in OPTBL. Used Safety Functions: STO

STO parameters	Value
Acknowledgment Mode (STO)	Manual

Table 100: Input/Output Parameters

Input/output parameters	Value
Digital Input 1	STO
Digital Input 2	Acknowledgment 1)

Table 101: General Parameters

General parameters	Value
Drive Reset	Enabled
Drive Acknowledgment	Enabled 2) Disabled 1)

1) and 2) indicate alternative options. Use values marked with the same number.

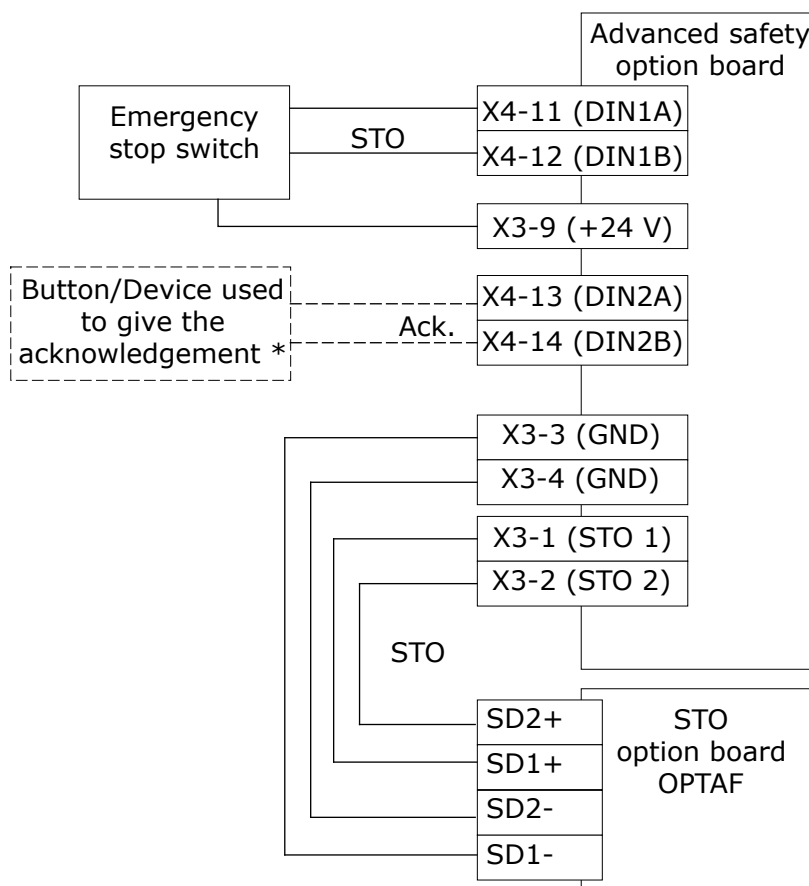

e30bi379;10

Illustration 77: Emergency Stop Configuration with the STO Function and Safe Acknowledgment

* = For some devices used for acknowledgment, additional wiring is required.

13.3 SS1 Used with STO(+SBC)

This is a configuration with the SS1 function and the STO function used with the SBC function in the Advanced safety option board OPTBL. No external safe reset or acknowledgment is required. The STO function is not directly requested externally. The drive reset is used to deactivate the STO function and to reset the faults.

The SS1 function is used in the time monitoring mode with a 4.75 s delay for the STO+SBC function activation. The SS1 function can operate in the automatic or the manual acknowledgment mode with the drive acknowledgment enabled. The SBC function is activated before the STO function, and the delay between the SBC function and the STO function is 250 ms. In practice, the STO function becomes active 5 s after the SS1 function is requested. The 250 ms is the value that is assumed for the mechanical delay and other delays in brake activation. The brake and the STO function are intended to become active at the same time. The parameter SBC Speed is not used.

The SS1 request is assigned to Digital Input 1 of the Advanced safety option board. The SBC output is assigned to Digital Output 1 of the option board. Monitoring of the ramp is not considered a safety critical feature. No safe speed measurement is necessary or is not considered for this configuration.

The drive application is used to execute the SS1 controlled ramp to zero.

Table 102: Configuration in OPTBL: Used Safety Functions: SS1, STO+SBC

STO parameters	Value
Acknowledgment Mode (STO)	N/A (no effect)
SBC Enabled	[Checkbox] Active
SBC Order	SBC first
SBC t1	0.25 s
SBC Speed	0 rpm

Table 103: Input/Output Parameters

Input/output parameters	Value
Digital Input 1	SS1
Digital Output 2	SBC

Table 104: General Parameters

General parameters	Value
Drive Reset	Enabled
Drive Acknowledgment	Enabled 2) Disabled 1)

Table 105: SS1 Parameters

SS1 parameters	Value
Acknowledgment Mode (SS1)	Automatic 1) Manual 2)
SS1 Monitoring	Time
SS1 Ramp Monitoring	–
SS1 t1	4.75 s
SS1 td1	–
SS1 td2	–

1) and 2) indicate alternative options. Use values marked with the same number.

When you use the safety-aware Multipurpose drive application, the SS1 function is realized by the drive application when the SS1 function is requested from the Advanced safety option board. The ramp definitions for controlled ramp are taken from the ramp 2 of the drive.

Table 106: Configuration in Safety-aware Multipurpose Drive Application

Parameter	Value
P2.12.1 S Stop Response	Ramp 2
P2.4.2 Ramp 2 Shape	0
P2.4.4 Deceleration Time 2	4 s

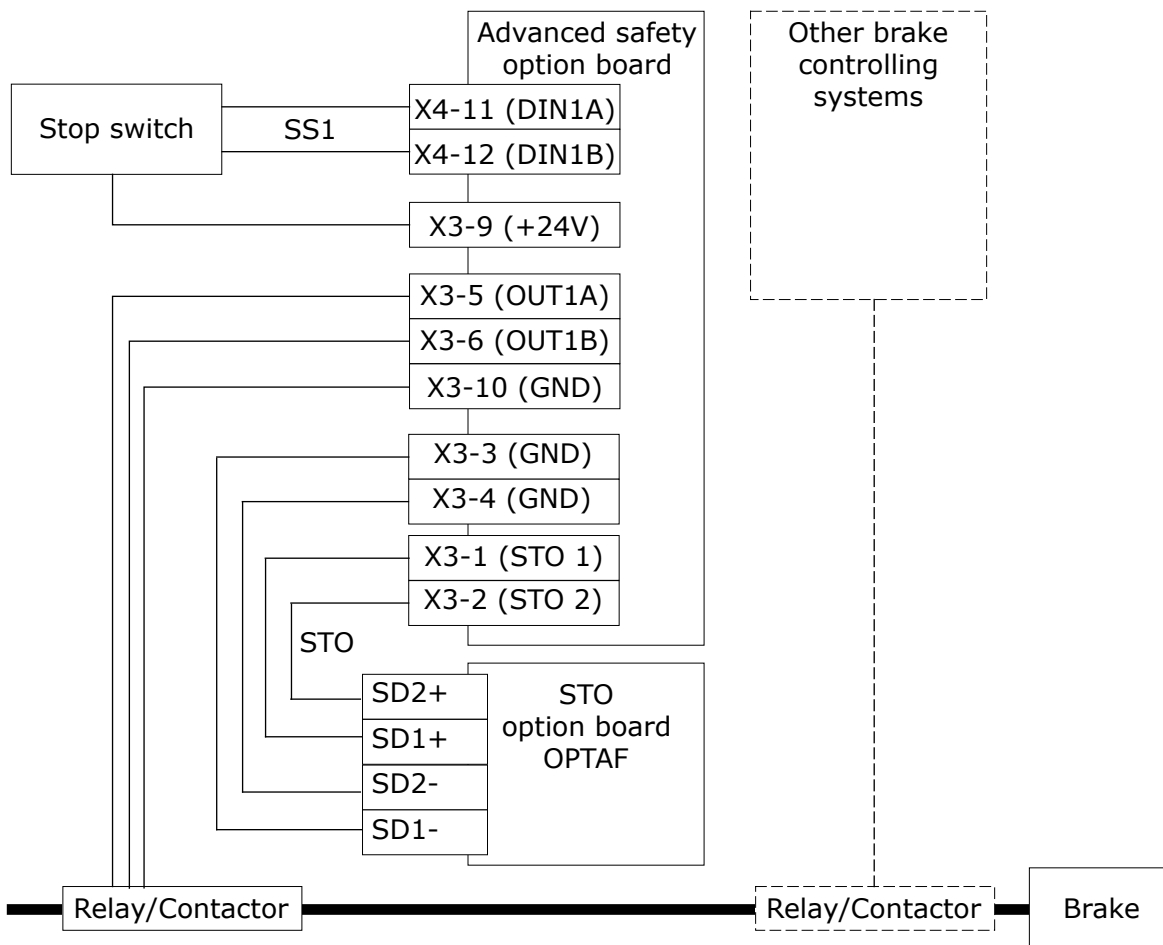

Illustration 78: The SS1 Function Used with the STO(+SBC) Function

NOTICE

The example above describes a system with only one brake. It is possible that some applications require 2 brakes.

NOTICE

The driving capability of the outputs of the Advanced safety option board is limited. Note this when you select the relay or contactor connected to the output.

NOTICE

The Advanced safety option board deactivates the STO function and the SBC function at the same time. It is possible to use other brake controlling systems to make sure that sufficient torque has been generated to the motor shaft before the brake is released.

NOTICE

If the execution of the ramp is safety critical, use safe speed measurement. This can be done, for example, by using an adequate speed measurement combination on the Advanced safety option board.

13.4 SS1 Without a Direct Support of the Drive Application

If there is no suitable drive application that supports the automatic SS1 ramp, the controlled ramp down can also be based on the external frequency reference that is supplied to the drive. When the SS1 function is requested from the drive, the speed reference is simultaneously used to ramp the speed down.

If different systems are used to request safety functions and supply the frequency reference, the digital output of the Advanced safety option board can be used to inform the frequency reference handling system about the SS1 request.

Table 107: Configuration in the OPTBM: Used Safety Functions: SS1

Input/output parameters	Value
Digital Output 2	Group 7
Operation for Output 2	OR
Group 7 for safe digital output 2	SS1_Active

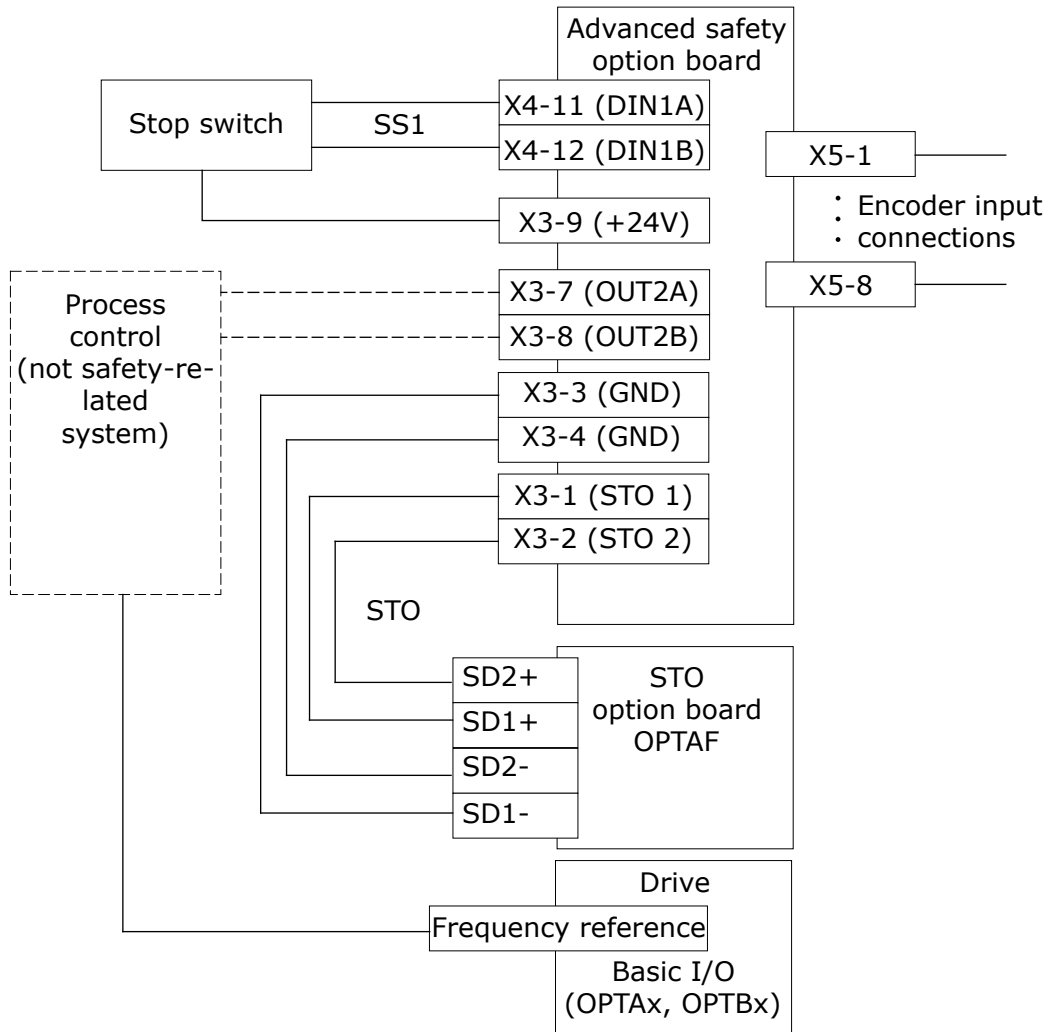

Illustration 79: The SS1 Function with a Controlled Ramp Down from a Process Control System

NOTICE

If the execution of the ramp is safety critical, use safe speed measurement. This can be done, for example, by using an adequate speed measurement combination on the Advanced safety option board.

NOTICE

If the execution of the ramp is not safety critical, it can be possible to use only one channel to indicate the SS1 Active to the external system.

13.5 Light Curtain Control of SLS

This configuration uses the SQS-SS1 function for a controlled stop of the motor and the SLS function to monitor the speed of the motor with the Advanced safety option board OPTBN. The SQS function is also used as a violation response of the SLS function. The SLS function is controlled by a light curtain. No external safe reset or acknowledgment is required. The SLS acknowledgment mode

should be set based on the use of the light curtain. If you want to prevent automatic deactivation of the SLS function after the light curtain detects no objects, use manual acknowledgment. The drive reset is used to deactivate the STO function and to reset the faults.

The SQS-SS1 function is used as a violation response of the SLS function and assigned to a digital input for requests. The SQS-SS1 function is used in time monitoring mode with a 5.0 s delay for the STO activation. The SQS-SS1 function can operate in the automatic or the manual acknowledgment mode with the drive acknowledgment enabled.

The SQS-SS1 request is assigned to Digital Input 1 of the Advanced safety option board. The SLS 1 control is assigned to Digital Input 2.

The drive application is used to limit the speed to the desired value. A Sin/Cos encoder is used to measure the speed of the motor shaft.

Table 108: Configuration in OPTBN: Used Safety Functions: SLS, SQS

SLS parameters	Value
Acknowledgment Mode (SLS)	Manual, Automatic
SLS Ramp Monitoring	None
SLS t1	5.0 s
SLS td1	–
SLS td2	20 ms
SLS td3	100 ms
SLS 1 Limit	250 rpm
SLS 2 Limit	0 rpm
SLS 3 Limit	0 rpm

Table 109: Input/Output Parameters

Input/output parameters	Value
Digital Input 1	SS1
Digital Input 2	SLS 1

Table 110: General Parameters

General parameters	Value
Drive Reset	Enabled
Drive Acknowledgment	Enabled 2) Disabled 1)

Table 111: Speed Measurement Configuration

Speed measurement configuration	Value
Encoder Type	Sin/Cos
Encoder power supply	15 V
Encoder reference signal	No reference signal

Speed measurement configuration	Value
Encoder number of pulses	1024
Proximity sensor number of pulses	–
Proximity sensor duty cycle	–

Table 112: SQS Parameters

SQS parameters	Value
Acknowledgment Mode (SQS)	Automatic 1) Manual 2)
SQS Type	SS1
SQS Monitoring	Time
SQS Ramp Monitoring	–
SQS t1	5.0 s
SQS td1	–
SQS td2	–

1) and 2) indicate alternative options. Use values marked with the same number.

When you use the safety-aware Multipurpose drive application, the ramp to stand still while the SQS-SS1 function is realized by the drive application when SQS-SS1 Active is indicated by the Advanced safety option board. The ramp definitions for the controlled ramp are taken from drive ramp 1.

The SLS speed limit is realized by the drive application when the SLS function is requested from the option board. The speed limit is taken from the Advanced safety option board. Drive application limits the speed to 95% of the parameterized limit. Ramping below the speed limit is realized by using drive ramp 1.

Table 113: Configuration in the Safety-aware Multipurpose Drive Application

Parameter	Value
P2.12.1 S Stop Response	Ramp 1
P2.12.2 SLS Response	Ramp 1
P2.4.1 Ramp 1 Shape	0
P2.1.4 Deceleration Time 1	4 s

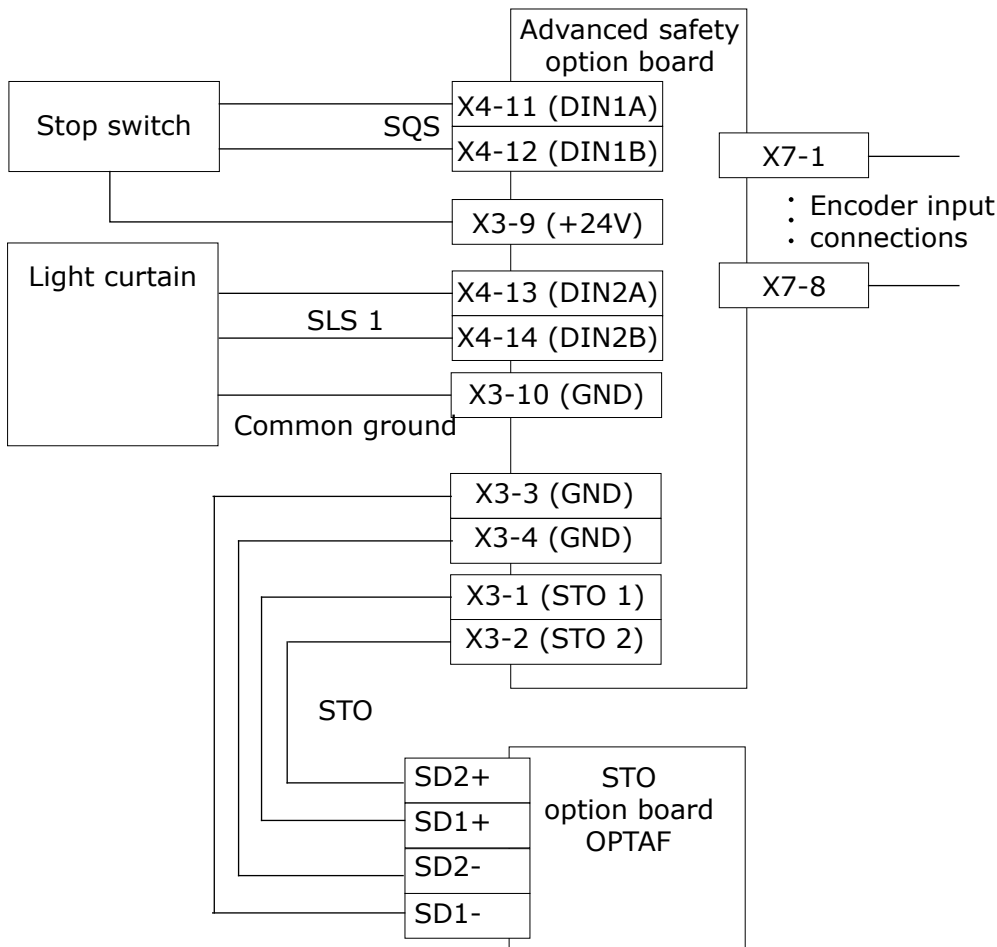

e30bi382.10

Illustration 80: Light Curtain Control of the SLS Function

NOTICE

The powering of the light curtain is not considered in this example. The light curtain must be powered by an adequate power source.

NOTICE

This example uses light curtain, but similar configurations can also be done with other devices.

13.6 SLS without a Direct Support of the Drive Application

If there is no suitable drive application that supports the automatic speed limiting during SLS safety function, the limited speed can also be executed based on the external frequency reference that is supplied to the drive. When the SLS function is requested from the drive, the speed reference is simultaneously used to ramp the speed down and kept below the limit of the SLS safety function.

If different systems are used to request safety functions and supply the frequency reference, the digital output of the Advanced safety option board can be used to inform the frequency reference handling system about the SLS request.

In case the speed limit monitored by the SLS safety function is violated, the SQS safety function will be executed. If SQS is used in other modes than SQS-STO, a ramping to standstill is expected to be executed. Without a drive application that executes the ramping, external system must use the speed reference to ramp the speed to zero or a stop command must be sent to the drive to execute a stop ramp. An output of the Advanced safety option can be used to supply an indication of a violation a safety function.

Table 114: Configuration in the OPTBM: Used Safety Functions: SLS, SQS

Input/output parameters	Value
Digital Output 1	Group 3
Operator for Output 1	OR
Group 3 for safe digital output 1	SLS 1 Active SLS 2 Active SLS 3 Active
Digital Output 2	Group 7
Operator for Output 2	OR
Group 8 for safe digital output 2	SQS Active

With the above configuration for output 2, the output will indicate the execution of SQS. SQS can then be triggered either by external request or violation of SLS. Both are indicated in the same way in the output allowing the external system to react to the safety function.

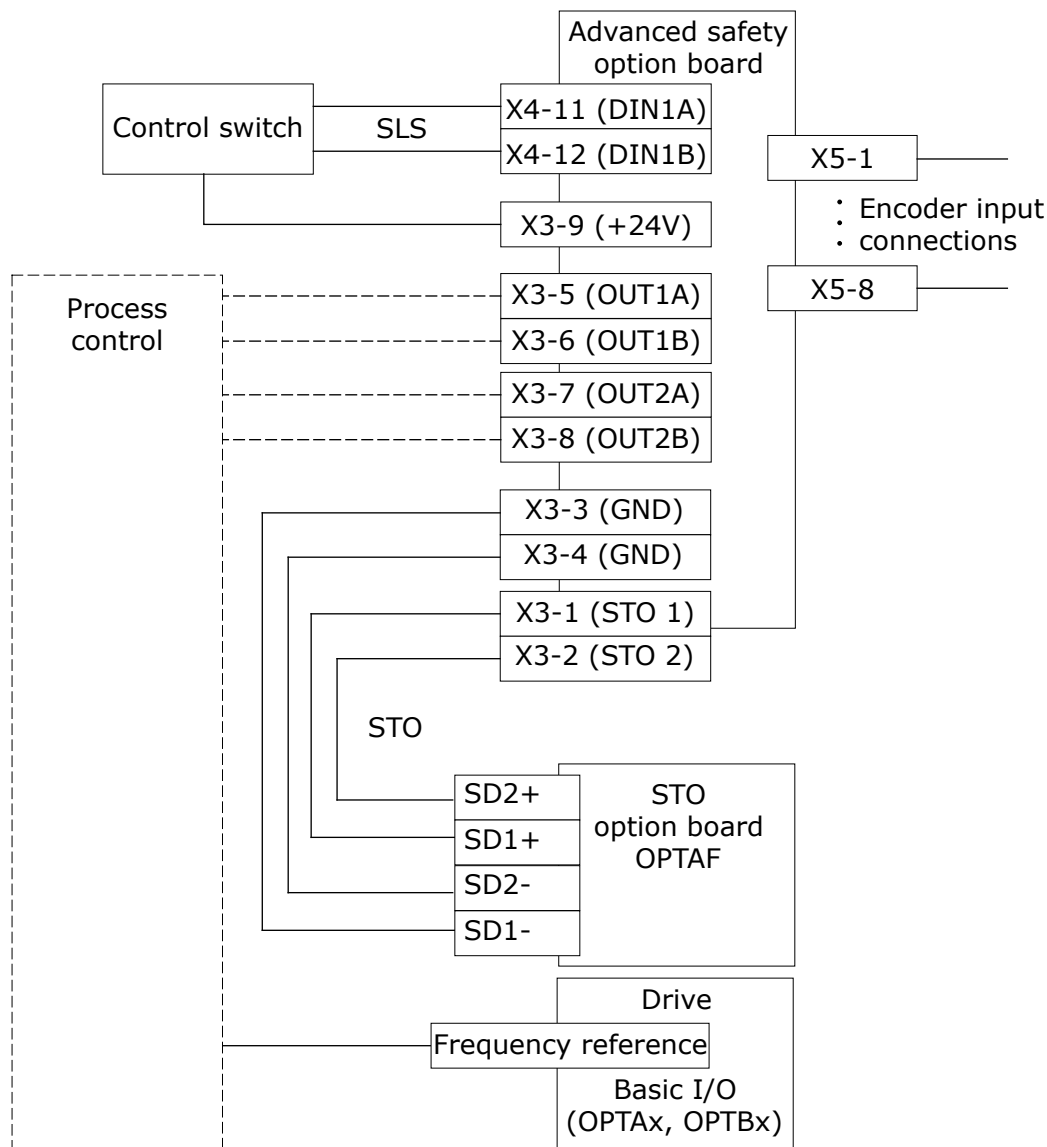

e30b412.10

Illustration 81: SLS and SQS Functions with Ramp and Speed Limitation Controlled by Process Control System

13.7 Using an Output of the Option Board to Control the Access to an Area

This configuration uses the SLS function to monitor the speed of the motor and to control an external door lock with the Advanced safety option board OPTBN. The SQS function is used as a violation response of the SLS function. The SLS function is controlled by an external system. An external acknowledgment is used. No external safe reset is required, the drive reset is used to deactivate the STO function and to reset the faults.

The SLS function operates in the manual acknowledgment mode with the drive acknowledgment disabled. SLS t1 is set to 5.0 s.

The SQS function is used only as violation response of the SLS function.

SLS 1 control is assigned to Digital Input 2. Digital Output 1 is used for the access control. The signal SLS 1 Reached is used to determine the state of Digital Output 1. When the signal SLS 1 Reached is active, the output is activated.

A Sin/Cos encoder is used to measure the speed of the motor shaft. External control for the speed reference to the drive is assumed for realizing the limited speed mode.

Table 115: Configuration in the OPTBN: Used Safety Functions: SLS, SQS

SLS parameters	Value
Acknowledgment Mode (SLS)	Manual
SLS Ramp Monitoring	None

SLS parameters	Value
SLS t1	5.0 s
SLS td1	0 ms
SLS td2	20 ms
SLS td3	100 ms
SLS 1 Limit	250 rpm
SLS 2 Limit	0 rpm
SLS 3 Limit	0 rpm

Table 116: Input/Output Parameters

Input/output parameters	Value
Digital Input 2	SLS 1
Digital Output 1	Group 2
Operation for Output 1	OR
Group 2 for safe digital output 1	SLS 1 Reached

Table 117: General Parameters

General parameters	Value
Drive Reset	Enabled
Drive Acknowledgment	Disabled

Table 118: SQS Parameters

SQS parameters	Value
Acknowledgment Mode (SQS)	(No effect)
SQS Type	STO
SQS Monitoring	–
SQS Ramp Monitoring	–
SQS t1	–
SQS td1	–
SQS td2	–

Table 119: Speed Measurement Configuration

Speed measurement configuration	Value
Encoder Type	Sin/Cos
Encoder power supply	15 V
Encoder reference signal	No reference signal

Speed measurement configuration	Value
Encoder number of pulses	1024
Proximity sensor number of pulses	-
Proximity sensor duty cycle	-

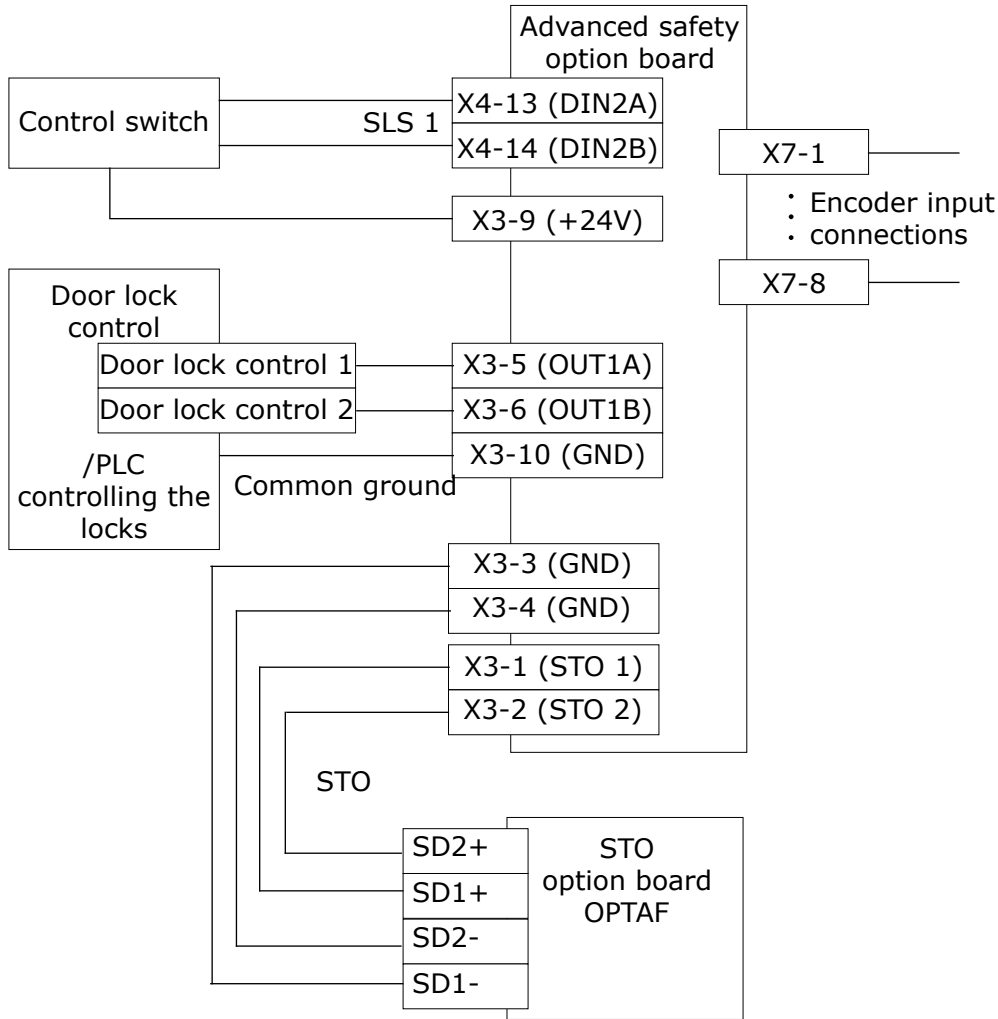

Illustration 82: An Output with SLS Reached used for Door Control

NOTICE

This example does not consider the source of the SLS request. Additional devices and connections may be required.

NOTICE

There should be an access behind the door when there is a power loss or a fault in the option board. Prevent the possibility of being trapped.

NOTICE

In this configuration, the door will be locked again if SLS monitoring is violated. Prevent the possibility of being trapped.

13.8 PROFIdrive over PROFIsafe Using the PROFIBUS or PROFINET Option Board

This is a configuration for realizing PROFIdrive over PROFIsafe with the Advanced safety option board OPTBN and the PROFIBUS option board OPTE5. The configuration for the option board OPTEA is in many ways the same. The physical layer is not serial bus but Ethernet, and the protocol is not PROFIBUS but PROFINET. For the option board OPTE3/5, you need to set the telegram configuration from the control panel of the drive, but the option board OPTEA receives the used telegram configuration when the PLC opens a connection to it. The digital inputs and outputs of the option board are not used. Reset and acknowledgment from the control board are not used. All safety features are controlled over PROFIsafe.

PROFIdrive over PROFIsafe is used to implement the STO, SS1, and SLS functions. The SQS function is used only as violation response to the SLS function. The PROFIdrive state machine is realized in the drive application.

Based on analysis on PROFIBUS, the PROFIsafe Watchdog Time (F WD Time) is set to 30 ms. The PROFIsafe F Source Address is set to 0x1000. The F Destination Address is set to 0x000D. The Safety Telegram 30 is selected.

Table 120: Configuration in OPTBN: Used Safety Functions: STO, SS1, SLS, SQS

STO parameters	Value
Acknowledgment Mode (STO)	Automatic

Table 121: SLS Parameters

SLS parameters	Value
Acknowledgment Mode (SLS)	Automatic
SLS Ramp Monitoring	None
SLS t1	5.0 s
SLS td1	0 ms
SLS td2	20 ms
SLS td3	0 ms
SLS 1 Limit	250 rpm
SLS 2 Limit	0 rpm
SLS 3 Limit	0 rpm

Table 122: Input/Output Parameters

Input/output parameters	Value
[No assignments]	–

Table 123: SQS Parameters

SQS parameters	Value
Acknowledgment Mode (SQS)	Automatic
SQS Type	SS1
SQS Monitoring	Time
SQS Ramp Monitoring	–
SQS t1	5.0 s
SQS td1	–
SQS td2	–

Table 124: General Parameters

General parameters	Value
Drive Reset	Disabled
Drive Acknowledgment	Disabled

Table 125: SS1 Parameters

SS1 parameters	Value
Acknowledgment Mode (SS1)	Automatic
SS1 Monitoring	Time
SS1 Ramp Monitoring	–
SS1 t1	5.0 s
SS1 td1	–
SS1 td2	–

Table 126: Speed Measurement Configuration

Speed measurement configuration	Value
Encoder Type	Sin/Cos
Encoder power supply	15 V
Encoder reference signal	No reference signal
Encoder number of pulses	1024
Proximity sensor number of pulses	–
Proximity sensor duty cycle	–

Table 127: Safe Fieldbus Parameters

Safe fieldbus parameters	Value
Fieldbus type	PROFIsafe
F Source Address	4096
F Destination Address	13
F WD Time	30 ms
Safety Telegram	30

Table 128: Configuration in the OPTE5 Option Board

Fieldbus parameters	Value
Telegram type	Standard Telegram 1 (ST1)
Operate mode	2 = Bypass

When running PROFIdrive application in NXP, bypass mode must be selected in OPTE5. If extra process data items are needed, a different telegram type with 4, 8, 12 & 16 process data items can be selected.

When you use the safety-aware Multipurpose drive application, the SS1 function is realized by the drive application when the SS1 function is requested from the Advanced safety option board. The ramp definitions for the controlled ramp are taken from drive ramp 1.

The SLS speed limit is realized by the drive application when the SLS function is requested from the Advanced safety option board. The speed limit is taken from the Advanced safety option board. The drive application limits the speed to 95% of the parameterized limit. Ramping below the speed limit is realized using drive ramp 1.

Table 129: Configuration in Safety-aware Multipurpose Drive Application

Parameter	Value
P2.12.1 S Stop Response	Ramp 1
P2.12.2 SLS Response	Ramp 1
P2.4.1 Ramp 1 Shape	0
P2.1.4 Deceleration Time 1	4 s

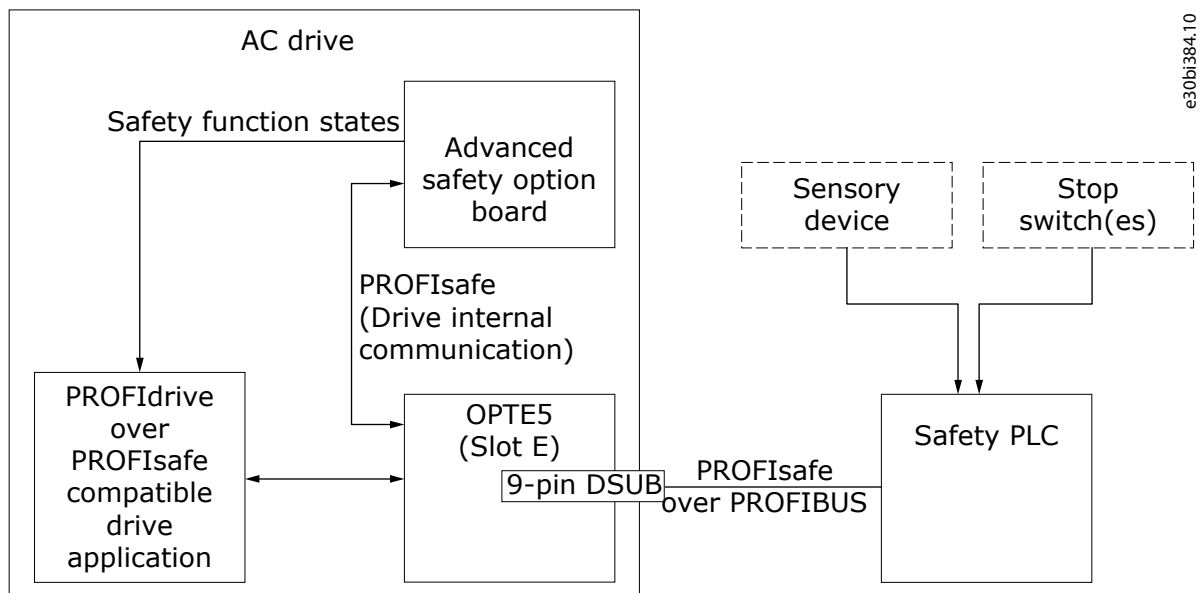

Illustration 83: Realizing PROFIdrive over PROFIsafe

13.9 A Proximity Sensor for Speed Measurement

This is a configuration for one proximity sensor with the Advanced safety option board OPTBL. No safety functions are included in this example. A proximity sensor with 16 pulses per rotation and an ACTIVE-INACTIVE signal duty cycle of 1:1 is used.

Table 130: Configuration in the OPTBL Option Board: Used Safety Functions: Not Considered.

Speed measurement configuration	Value
Encoder Type	1 proximity sensor
Encoder Power Supply	–
Encoder Reference Signal	No reference signal
Encoder Number of Pulses	–
Proximity Sensor Number of Pulses	16
Proximity Sensor Duty Cycle	50

Table 131: Input/Output Parameters

Input/output parameters	Value
Digital Input 1	Used for a proximity sensor.

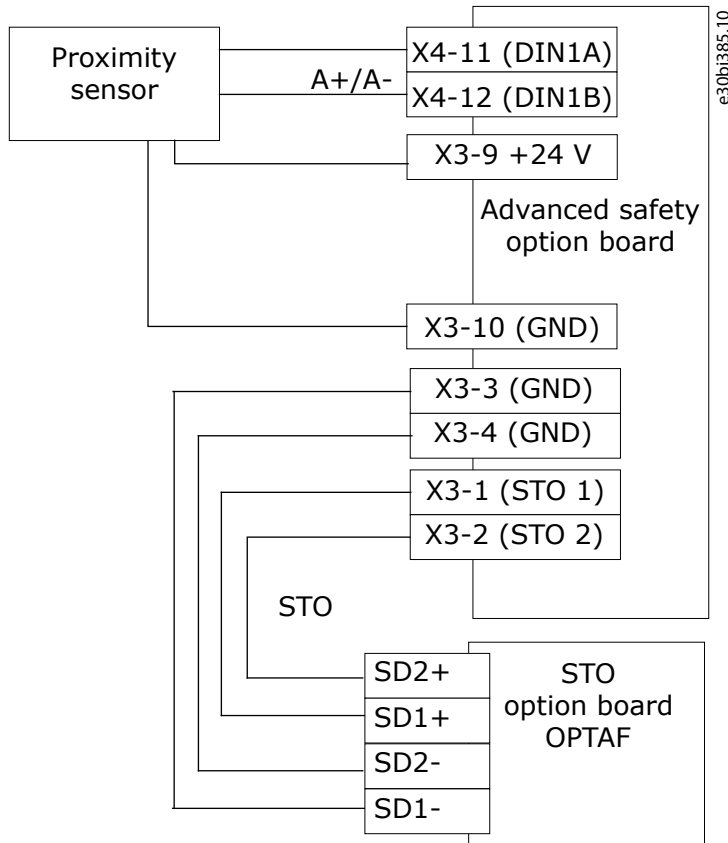

Illustration 84: Using 1 Proximity Sensor

Index

A	
Active state.....	58
Activity log.....	56
Additional resources.....	9
C	
Certificate.....	14
Closed-loop control.....	33, 33
D	
Designing a safety system.....	15, 25
Disposal.....	144
E	
EC Declaration of Conformity.....	14
Encoder.....	35
Estimated speed.....	40, 42
F	
Fault types.....	49
Firmware version.....	10
G	
Grounding principle.....	22
I	
Installation.....	51
M	
Manual version.....	10
Menu structure.....	45
P	
Parameter backup.....	43, 44, 44
Parameter file.....	54, 56
Password.....	53
Priority of the safe stopping functions.....	66
Proximity sensor.....	38
Purpose of the manual.....	9
Q	
Qualified personnel.....	9
R	
Resetting a safety function.....	63
S	
Safe monitoring function.....	57
Safe state.....	24
Safe stopping function.....	57
Safety.....	19, 20
Safety functions.....	15
Slot compatibility.....	27
Software download.....	9
Speed measurement.....	35
Speed sensor.....	33, 39
Standards.....	9
Supervision of encoders.....	39
Symbols.....	19
T	
Terminals.....	30, 31, 32
U	
Unverified parameter file.....	53
V	
VACON NXP AC drive.....	44
Validated parameter file.....	53
Verified parameter file.....	53

COMMISSIONING REPORT

TABLE OF CONTENTS

- 1 GENERAL 2**
 - 1.1 PURPOSE 2
 - 1.2 REFERENCES 2
 - 1.3 DISCLAIMER 2
- 2 DRIVE CONFIGURATION..... 3**
- 3 VALIDATION STEPS..... 4**
 - 3.1 GENERAL TESTING INSTRUCTIONS 4
 - 3.2 PREPARING FOR COMMISSIONING 4
 - 3.3 DIGITAL OUTPUT TESTS 6
 - 3.4 FIRST START-UP AFTER THE INSTALLATION OF THE OPTION BOARD..... 6
 - 3.5 RESET AND ACKNOWLEDGEMENT TESTS 7
 - 3.6 SAFE FIELDBUS TESTS 8
 - 3.7 SAFETY FUNCTION TESTS 9
 - 3.7.1 *STO + SBC* 9
 - 3.7.2 *SS1* 10
 - 3.7.3 *SS2 + SOS*..... 12
 - 3.7.4 *SQS* 13
 - 3.7.5 *SLS* 18
 - 3.7.6 *SMS* 19
 - 3.7.7 *SSR*..... 21
 - 3.7.8 *SSM* 22
 - 3.8 AFTER COMMISSIONING 24
- 4 SIGNATURE 25**

1 General

1.1 Purpose

This document is a commissioning report that contains the test instructions and a report of the testing that is executed during commissioning of an Advanced safety option board.

If the safety configuration is changed later, the commissioning tests must be executed and documented again.

The commissioning report can be printed or stored electronically. The document should be a part of the technical file of the machine.

For detailed description of the Advanced safety option board and its features, see the Advanced safety options Operating Guide.

1.2 References

The documents for VACON® products can be found in <http://drives.danfoss.com/knowledge-center/technical-documentation/>

- Advanced safety options Operating Guide

1.3 Disclaimer

The compilation of information contained in this report relies upon configuration provided by the user (or a person on whose behalf it is used) and is intended as a guide with purpose to test the safety configuration(s) of an AC drive. It is not designed to replace or be used instead of an appropriately designed safety test plan for each individual application. Several outside factors can influence the functional safety, including other peripheral equipment within the plant and other neighbouring plants.

Each safety function that is used in a system must be carefully tested. The test results must be documented and signed by the qualified personnel. This commissioning report can be used for such purpose. It is not mandatory to use this commissioning report when the Advanced safety option board is used. This report is meant as a help and might not be sufficient for the safety system.

The use of this report does not relieve the user of any obligation or duty that might arise under any legislation covering the activities to which this documents has been or is to be applied.

The information contained herein is without warranty of any kind and does not constitute a guarantee that the information is complete, current or correct and accepts no responsibility for unsuitable or inaccurate material that may be encountered.

2 Drive configuration

Table 1: The AC drive

Drive Type	
Serial Numbers	
Firmware name	
Firmware version	
Application Name	
Application Version	

Table 2: The option boards

Slot A	
Slot B	
Slot C	
Slot D	
Slot E	

Table 3: The Advanced safety option board

SW version	
File Name	
File Creator	
Creation Date	
Used Safety Functions	
Safe fieldbus type	
Encoder type	
Admin password	
Service password	

3 Validation steps

3.1 General testing instructions

The commissioning tests in this document are focused on validating the functionality of the integrated safety functions and the related stopping and monitoring functions configured in the drive system.

The test objective is to verify proper configuration of the defined safety functions and of test mechanisms, and to examine the response of specific monitoring functions to the explicit input of values outside tolerance limits. The test must cover all drive-specific safety functions used in the final setup.

The way that the testing can be executed depends both on the configuration that is used for the safety system and the general control of the process. At times the general control of the process may prevent the process from reaching a monitoring limit at which the safety response would be triggered. Where possible, other means of handling the safety should be disabled so that the safety responses executed by the safety system, including the Advanced safety option board, can be tested.

The order of tests should be considered. The safety functions used for stopping the motor should be tested first. After the correct operation of the stopping functions has been verified, the monitoring functions using these functions can be tested. The test steps in this document are listed in order that is generally assumed to be usable for the testing.

The safety function specific instructions instruct to activate the tested safety function from the desired source. Safety functions can be requested either from a digital input or over safe fieldbus, and any source that is being used should be tested. If both a digital input and a safe fieldbus is used to request a safety function, the test for that safety function should be executed for both these sources.

If an unexpected violation occurs or an expected violation does not occur, try to understand the reason for the incident. The reason could be related to

- a) the parameterisation of ramp monitoring (the defined ramps are too strict/forgiving),
- b) incorrect wiring that results in wrong safety functions being requested,
- c) the system controlling the speed does not react to the safety functions in the expected way or at all.

3.2 Preparing for commissioning

NOTE! The information in this chapter is also included in the Advanced safety options Operating Guide.

If it is possible, commission the AC drive first without the Advanced safety option board to make sure that your process is operational.

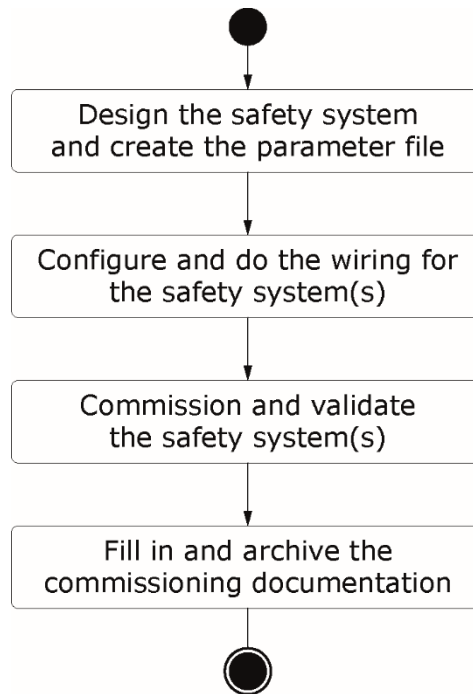

Figure 1: Preparing and commissioning a safety system that includes the Advanced safety option board

Preparing for the commissioning before the first start-up of the system with the option board

1. Read carefully the warnings in chapter Safety of the Advanced safety options Operating Guide.
2. Read the Advanced safety options Operating Guide and the Commissioning report and apply their instructions in the commissioning plan.
3. Read the User Manual of the AC drive.
4. Refer to the user manuals of other subsystems connected to the commissioned drive system.
5. Define the parameter file for the Advanced safety option board.
6. Make sure that the hardware and configuration are correct, and that the software is correct in the components of the AC drive and its subsystems.
7. Make sure that the information of the commissioned AC drive matches the information in the commissioning plan and the Commissioning report.
8. Make sure that the connections between different systems have been checked and are ready to be used.
9. Make sure that the area affected by the commissioned systems is free and secure for the commissioning.
10. Make sure that no danger can be caused to personnel if the system has been configured incorrectly and behaves unexpectedly.
11. Make sure that the AC drive is correctly parameterised and commissioned for use.
 - The motor parameters have been set.
 - The identification run has been done. Preferred identification type: identification with run or encoder ID run.

- The fieldbus connection can be established. (If a fieldbus is used.)
12. Have a computer available with a software to control and parameterise the AC drive and the option boards, and to store test logs and parameters.
 13. Have the Commissioning report available.

Document the deviations compared to expected results during the commissioning and testing procedures. Do not release the system for use if any unacceptable deviations exist.

3.3 Digital output tests

Depending on the use of the configurable outputs of the option board, specific tests may be required for the systems that monitor these outputs.

In general, the required test steps for the outputs used as SBC output or SSM output are included in the STO + SBC and SSM parts of the test steps.

For other uses of the outputs, follow these guidelines:

1. The correct response of the system monitoring an output should be tested for each output.
2. Do a test of the response to a cable breakdown. In practice, this covers the situation where the power to the option board is unexpectedly cut.
3. It may be possible to verify the correct configuration and operation of the outputs during the safety function tests. If not, special test(s) should be planned to verify the correct configuration and operation of the outputs and the systems that monitor them.

3.4 First start-up after the installation of the option board

NOTE! The information in this chapter is also included in the Advanced safety options Operating Guide.

After the option board is installed in the AC drive, do these steps.

Table 4: First start-up with the Advanced safety option board

Step	Instructions	Comments
1	Do power-up on the AC drive.	
2	<p>The drive shows the fault F38 DeviceAdded (example: slot D, subcode 1 if Advanced safety option is installed in slot D).</p> <p>NOTE! The actual faults shown depend on the configuration used during the previous start-up if other changes have also been made.</p> <p>If the option board was already installed and tested at the factory, the fault is not shown.</p> <p>NOTE! Other faults are also shown: the warning for Safe Torque Off (F30, subcode: 1) and the fault for Safety System (F20 SafetySystem, source: 82 - Plaus. check, fault number: 3). Fault F20 indicates that the option board has no valid parameter file.</p> <p>NOTE! At start-up, the option board also does diagnostic self-tests. If other F20 SafetySystem faults are shown, see</p>	

	the Advanced safety options Operating Guide for more information.	
3	Reset the faults.	
4	<p>The drive is not ready. The warning F30 SafeTorqueOff is shown.</p> <p>NOTE! If the option board has been used in a previous configuration, it is possible that it has a valid parameter file already. In this case, the drive may be in READY state.</p> <p>NOTE! The faults that are shown and their type (Fault or Alarm) depend on the settings of the AC drive.</p> <p>NOTE! STO state can also be seen from the STO option board diagnostic relay output.</p>	
5	Parameterise the option board using the VACON® Safe tool.	
6	<p>After parameterisation the fault F20 (source: 82, fault number: 3) no longer appears.</p> <p>NOTE! Depending on the parameterised safety functions and the state of the option board inputs, different safety functions can be reported as requested or reached.</p> <p>The fault F20 (source: 243 - drive conf, fault number: 2) appears. The fault indicates that the parameter file is not tested and validated.</p>	
7	Print the prefilled Commissioning report from the VACON® Safe tool or save the report in digital form.	
8	Test the safe fieldbus, or if a safe fieldbus is not used, the relevant safety functions.	

The correct installation of the Advanced safety option board has been verified and documented.

The Advanced safety option board has been parameterised with the intended configuration.

Notes:

3.5 Reset and Acknowledgement tests

The correct operation of the reset and acknowledgement signals will be tested together with the safety functions. If possible, the signals should also be tested independently before proceeding to the safety functions.

The acknowledgement and reset signals of the option board can be sent:

- using a safe I/O of the option board
- using a safe fieldbus
- from the drive control board (triggered by the fault reset signal of the AC drive).

Depending on the configuration, some of the methods may be disabled or not taken into use.

If the Advanced safety option board is set to the manual start-up acknowledgement mode, an acknowledgement signal is required after the start-up to deactivate the STO safety function.

Fill in these steps when the signals are tested (independently or together with the safety function tests):

- Acknowledgement signal tested for start-up (manual start-up ack.)
- Acknowledgement via control board tested
- Acknowledgement via option board safe I/O tested
- Acknowledgement via safe fieldbus tested
- Reset via control board tested
- Reset via option board safe I/O tested
- Reset via safe fieldbus tested

Notes:

3.6 Safe fieldbus tests

Step	Instructions	Comments
1	Do power-up on the AC drive.	
2	Do power-up on the safe fieldbus related devices (PLC, routers, etc.)	
3	The safe fieldbus connection is established. The drive is in READY state.	
4	Activate a safety function over the safe fieldbus.	
5	Make sure that the safety function becomes active in the drive and that applicable warnings/faults are shown. NOTE! The warning(s) and/or fault(s) shown depend on the used safety function and configuration. Make sure that the correct state is reported back over the safe fieldbus.	
6	Deactivate the safety function.	

	If necessary, acknowledge the safety function or reset the violations if violations occurred.	
7	Repeat the steps 3 to 6 for each safety function intended to be used over the safe fieldbus. This can be done as a part of the safety function tests listed in following chapters.	

Safe fieldbus tests have been executed and possible deviations documented.



Notes:

3.7 Safety function tests

If this document was printed from the VACON® Safe tool after the parameterisation of the Advanced safety option board, this chapter should list all the safety functions that are used in the option board. Examine possible differences.

If a safety function is intended to be used from both a digital input and a fieldbus, test the safety function with the both of them.

3.7.1 STO + SBC

Here you can find the testing instructions for the STO and SBC functions. Do the SBC steps if the SBC function is used.

Step	Instructions	Comments
STO-1	Make sure that the drive is in READY state. Make sure that no safety functions are requested.	
	SBC-1 Make sure that the mechanical brake is deactivated. Make sure that SBC Reached is deactivated in the used status output: <ul style="list-style-type: none"> - The physical output of the option board - The safe fieldbus status message 	
STO-2	Activate the STO function from the desired source.	
STO-3	Make sure that the drive is not in READY state. Applicable faults are shown: Warning: F30 SafeTorqueOff, subcode: 1. Warning: F46 SafetyRequest, subcode: STO (1). NOTE! The faults that are shown and their type (Fault or Warning) depend on the settings of the AC drive.	

	SBC-2	<p>The mechanical brake becomes active as expected.</p> <p>SBC Reached is indicated in the used status output:</p> <ul style="list-style-type: none"> - The physical output of the option board - The safety fieldbus status message <p>Caution: Depending on the parameterisation the brake may become active before the STO function is activated.</p>	
STO-4	<p>Deactivate the STO function.</p> <p>If the manual acknowledgement mode is used: do a check that the STO function is not deactivated automatically. Activate the acknowledgement from the desired source.</p> <p>If there are faults and if they were expected, reset them.</p> <p>NOTE! When a safety function is deactivated, and there is a valid RUN request in the AC drive, the AC drive can start running unexpectedly.</p>		
STO-5	<p>Make sure that the drive is in READY state.</p>		
	SBC-3	<p>Make sure that the mechanical brake is deactivated.</p> <p>Make sure that SBC Reached is deactivated in the used status output:</p> <ul style="list-style-type: none"> - The physical output of the option board - The safe fieldbus status message 	

The STO+SBC tests have been executed, possible deviations documented and testing approved. □

Notes:

3.7.2 SS1

Step	Instructions	Comments
1	<p>Make sure that the drive is in READY state.</p> <p>Make sure that no safety functions are requested.</p>	

2	Give a RUN request to the AC drive.	
3	Activate the SS1 function from the desired source.	
4	<p>The drive should ramp down towards standstill. The behaviour of the ramp down is dependent on the way the ramp down is realised (e.g. drive application, external speed reference).</p> <p>Depending on the selected SS1 mode:</p> <p>Time mode:</p> <p>The STO function is activated after a delay. Make sure that the delay is correct for the process.</p> <p>Time + Zero speed mode:</p> <p>The STO function is activated after the speed goes below a defined speed.</p> <p>Time + Zero speed + Ramp mode:</p> <p>The STO function is activated after the speed goes below a defined speed. The ramp is monitored by the option board.</p> <p>NOTE! If the Time + Zero speed + Ramp mode is used and the controlled ramp down not following the intended ramp is a critical enough deviation, re-execute this test to determine that the monitored ramps are sufficient for the process.</p>	
5	<p>Make sure that the drive is in NOT READY state.</p> <p>Applicable faults are shown on the control panel of the AC drive:</p> <p>Warning: F30 SafeTorqueOff, subcode: 1. Warning: F46 SafetyRequest, subcode: SS1 (2). Warning: F47 SafetyReached, subcode: SS1 (2).</p> <p>NOTE! The faults that are shown and their type (Fault or Warning) depend on the settings of the AC drive.</p>	
6	<p>Deactivate the SS1 function.</p> <p>If the manual acknowledgement mode is used: do a check that the STO function is not deactivated automatically. Activate the acknowledgement from the desired source.</p> <p>If there are faults and if they were expected, reset them.</p> <p>NOTE! When a safety function is deactivated, and there is a valid RUN request in the AC drive, the AC drive can start running unexpectedly.</p>	
7	The drive is in READY state.	

The SS1 tests have been executed, possible deviations documented and testing approved.

Notes:

3.7.3 SS2 + SOS

Step	Instructions	Comments
1	Make sure that the drive is in READY state. Make sure that no safety functions requested.	
2	Give a RUN request to the AC drive.	
3	Activate the SS2 function from the desired source.	
4	<p>The drive should ramp down towards standstill. The behaviour of the ramp down is dependent on the way the ramp down is realised (e.g. drive application, external speed reference).</p> <p>Depending on the selected SS2 mode:</p> <p>Time mode: The SOS function is activated after a delay. Make sure that the delay is correct for the process.</p> <p>Time + Zero speed mode: The SOS function is activated after the speed goes below a defined speed.</p> <p>Time + Zero speed + Ramp mode: The SOS function is activated after the speed goes below a defined speed. The ramp is monitored by the option board.</p> <p>NOTE! If the Time + Zero speed + Ramp mode is used and the controlled ramp down not following the intended ramp is a critical enough deviation, re-execute this test to determine that the monitored ramps are sufficient for the process.</p>	
5	<p>Make sure that the drive is in READY state.</p> <p>Applicable faults are shown: Warning: F46 SafetyRequest, subcode: SS2 (3). Warning: F47 SafetyReached, subcode: SS2 (3).</p>	

	<p>NOTE! The faults that are shown and their type (Fault or Warning) depend on the settings of the AC drive.</p> <p>NOTE! F47 SafetyReached, subcode: SS2 (3), indicates that the SS2 safety function is Reached and that the SOS safety function is active.</p>	
6	Make the motor rotate so that the rotation exceeds the SOS position deviation limit.	
7	<p>Make sure that the position deviation at which the SOS safety function detects the rotation violation is valid for the process.</p> <p>The expected violations:</p> <p>Warning: F48 SafetyViolat, Safety function: SOS, Fault number: 1.</p>	
8	Make sure that the drive is in NOT READY state.	
9	<p>Deactivate the SS2 function.</p> <p>Send a reset signal to the option board.</p> <p>NOTE! When a safety function is deactivated, and there is a valid RUN request in the AC drive, the AC drive can start running unexpectedly.</p>	
10	Make sure that the drive is in READY state.	

The SS2 tests have been executed, possible deviations documented and testing approved.

Notes:

3.7.4 SQS

3.7.4.1 SQS-STO

The SQS function as a violation response is tested during the testing of a safety function that uses the SQS function as its violation response.

The SQS-STO function from an external source: the test instructions are similar to that of STO + SBC test instructions in 3.7.1 STO + SBC.

Step	Instructions	Comments
STO-1	<p>Make sure that the drive is in READY state.</p> <p>Make sure that no safety functions are requested.</p>	

	SBC-1	<p>Make sure that the mechanical brake is deactivated.</p> <p>Make sure that SBC Reached is deactivated in the used status output:</p> <ul style="list-style-type: none"> - The physical output of the option board - The safe fieldbus status message 	
STO-2	Activate the SQS function from the desired source.		
STO-3	<p>Make sure that the drive is not in READY state.</p> <p>Applicable faults are shown:</p> <p>Warning: F30 SafeTorqueOff, subcode: 1. Warning: F46 SafetyRequest, subcode: SQS (4). Warning: F47 SafetyReached, subcode: SQS (4).</p> <p>NOTE! The faults that are shown and their type (Fault or Warning) depend on the settings of the AC drive.</p>		
	SBC-2	<p>The mechanical brake becomes active as expected.</p> <p>SBC Reached is indicated in the used status output:</p> <ul style="list-style-type: none"> - The physical output of the option board - The safety fieldbus status message <p>Caution: Depending on the parameterisation the brake may become active before the STO function is activated.</p>	
STO-4	<p>Deactivate the SQS function.</p> <p>If the manual acknowledgement mode is used: do a check that the STO function is not deactivated automatically. Activate the acknowledgement from the desired source.</p> <p>If there are faults and if they were expected, reset them.</p> <p>NOTE! When a safety function is deactivated, and there is a valid RUN request in the AC drive, the AC drive can start running unexpectedly.</p>		
STO-5	Make sure that the drive is in READY state.		
	SBC-3	<p>Make sure that the mechanical brake is deactivated.</p> <p>Make sure that SBC Reached is deactivated in the used status output:</p> <ul style="list-style-type: none"> - The physical output of the option board - The safe fieldbus status message 	

The SQS-STO tests have been executed, possible deviations documented and testing approved.



Notes:

3.7.4.2 SQS-SS1

The SQS function as a violation response is tested during the testing of a safety function that uses the SQS function as its violation response.

The SQS-SS1 function from an external source: the test instructions are similar to that of SS1 test instructions in 3.7.2 SS1.

Step	Instructions	Comments
1	Make sure that the drive is in READY state. Make sure that no safety functions are requested.	
2	Give a RUN request to the AC drive.	
3	Activate the SQS function from the desired source.	
4	The drive should ramp down towards standstill. The behaviour of the ramp down is dependent on the way the ramp down is realised (e.g. drive application, external speed reference). Depending on the selected SQS-SS1 mode: Time mode: The STO function is activated after a delay. Make sure that the delay is correct for the process. Time + Zero speed mode: The STO function is activated after the speed goes below a defined speed. Time + Zero speed + Ramp mode: The STO function is activated after the speed goes below a defined speed. The ramp is monitored by the option board. NOTE! If the Time + Zero speed + Ramp mode is used and the controlled ramp down not following the intended ramp is a critical enough deviation, re-execute this test to determine that the monitored ramps are sufficient for the process.	
5	Make sure that the drive is in NOT READY state. Applicable faults are shown on the control panel of the AC drive: Warning: F30 SafeTorqueOff, subcode: 1.	

	Warning: F46 SafetyRequest, subcode: SQS (4). Warning: F47 SafetyReached, subcode: SQS (4). NOTE! The faults that are shown and their type (Fault or Warning) depend on the settings of the AC drive.	
6	Deactivate the SQS function. If the manual acknowledgement mode is used: do a check that the STO function is not deactivated automatically. Activate the acknowledgement from the desired source. If there are faults and if they were expected, reset them. NOTE! When a safety function is deactivated, and there is a valid RUN request in the AC drive, the AC drive can start running unexpectedly.	
7	The drive is in READY state.	

The SQS-SS1 tests have been executed, possible deviations documented and testing approved.

Notes:

3.7.4.3 SQS-SS2

The SQS function as a violation response is tested during the testing of a safety function that uses the SQS function as its violation response.

The SQS-SS2 function from an external source: the test instructions are similar to that of SS2 test instructions in 3.7.3 SS2 + SOS.

Step	Instructions	Comments
1	Make sure that the drive is in READY state. Make sure that no safety functions requested.	
2	Give a RUN request to the AC drive.	
3	Activate the SQS function from the desired source.	
4	The drive should ramp down towards standstill. The behaviour of the ramp down is dependent on the way the ramp down is realised (e.g. drive application, external speed reference). Depending on the selected SQS-SS2 mode:	

	<p>Time mode:</p> <p>The SOS function is activated after a delay. Make sure that the delay is correct for the process.</p> <p>Time + Zero speed mode:</p> <p>The SOS function is activated after the speed goes below a defined speed.</p> <p>Time + Zero speed + Ramp mode:</p> <p>The SOS function is activated after the speed goes below a defined speed. The ramp is monitored by the option board.</p> <p>NOTE! If the Time + Zero speed + Ramp mode is used and the controlled ramp down not following the intended ramp is a critical enough deviation, re-execute this test to determine that the monitored ramps are sufficient for the process.</p>	
5	<p>Make sure that the drive is in READY state.</p> <p>Applicable faults are shown:</p> <p>Warning: F46 SafetyRequest, subcode: SQS (4). Warning: F47 SafetyReached, subcode: SQS (4).</p> <p>NOTE! The faults that are shown and their type (Fault or Warning) depend on the settings of the AC drive.</p> <p>NOTE! F47 SafetyReached, subcode: SQS (4), indicates that the SQS-SS2 safety function is Reached and that the SOS safety function is active.</p>	
6	<p>Make the motor rotate so that the rotation exceeds the SOS position deviation limit.</p>	
7	<p>Make sure that the position deviation at which the SOS safety function detects the rotation violation is valid for the process.</p> <p>The expected violations:</p> <p>Warning: F48 SafetyViolat, Safety function: SOS, Fault number: 1.</p>	
8	<p>Make sure that the drive is in NOT READY state.</p>	
9	<p>Deactivate the SQS function.</p> <p>Send a reset signal to the option board.</p> <p>NOTE! When a safety function is deactivated, and there is a valid RUN request in the AC drive, the AC drive can start running unexpectedly.</p>	
10	<p>Make sure that the drive is in READY state.</p>	

The SQS-SS2 tests have been executed, possible deviations documented and testing approved.

Notes:

3.7.5 SLS

When possible, test the SQS safety function before the SLS safety function. Do the test steps for all the used SLS limits.

Step	Instructions	Comments
1	Make sure that the drive is in READY state. Make sure that no safety functions requested.	
2	Give a RUN request to the AC drive. The speed should be in the safe range below the SLS limit that is being tested.	
3	Activate the SLS function from the desired source.	
4	A warning should occur to indicate the SLS function activation: Warning: F46 SafetyRequest, subcode: SLS (6). Warning: F47 SafetyReached, subcode: SLS (6). NOTE! The display of the warning depends on the settings of the AC drive. NOTE! Depending on the SLS mode, the function may be reached after a specified time or almost immediately (once the speed is below the limit). Once the function is reached the "request" warning should disappear.	
5	Increase the speed above the reached SLS limit.	
6	The SQS function becomes active once speed exceeds the limit and the SLS function detects the violation. Do a check that the violation occurs at the expected speed.	
7	Verify that the SQS function operates correctly and is suitable for the process. NOTE! The SQS function may be operating in the STO, SS1, or SS2 mode.	
8	Make sure that the motor is stopped.	

	<p>Applicable faults are shown:</p> <p>Warning: F47 SafetyReached, subcode: SQS (4). Warning: F48 SafetyViolat, Safety function: SLS, subcode: 5.</p> <p>NOTE! The faults that are shown and their type (Fault or Warning) depend on the settings of the AC drive.</p> <p>The drive is in NOT READY state or in RUN state.</p> <p>NOTE! In the SQS-SS2 mode the drive should stay in RUN state. In the SQS-STO or the SQS-SS1 mode the drive should be in NOT READY state.</p>	
9	<p>Deactivate the SLS function.</p> <p>Send a reset signal to the option board.</p> <p>NOTE! When a safety function is deactivated and the violation is reset, and there is a valid RUN request in the AC drive, the AC drive can start running unexpectedly.</p>	
10	<p>Make sure that the drive is in READY state.</p>	
11	<p>When necessary, repeat the tests for other SLS limits.</p>	

The SLS tests have been executed, possible deviations documented and testing approved.

Notes:

3.7.6 SMS

When possible, test the SQS safety function before the SMS safety function. Do the test steps for all the used SMS limits.

Step	Instructions	Comments
1	<p>Make sure that the drive is in READY state.</p> <p>Make sure that no safety functions requested.</p>	
2	<p>Give a RUN request to the AC drive.</p> <p>The speed should be in the safe range below the SMS limit(s).</p>	
3	<p>Activate the SMS function from the desired source.</p>	

4	<p>A warning should occur to indicate the SMS function activation: Warning: F46 SafetyRequest, subcode: SMS (12). Warning: F47 SafetyReached, subcode: SMS (12).</p> <p>NOTE! The display of the warning depends on the settings of the AC drive.</p> <p>NOTE! Depending on the SMS parameter values, the function may be reached after a delay. Once the function is Reached, the "request" warning should disappear.</p>	
5	Increase the speed above the SMS limit.	
6	<p>The SQS function becomes active once speed exceeds the limit and the SMS function detects the violation.</p> <p>Do a check that the violation occurs at the expected speed.</p>	
7	<p>Verify that the SQS function operates correctly and is suitable for the process.</p> <p>NOTE! The SQS function may be operating in the STO, SS1, or SS2 mode.</p>	
8	<p>Make sure that the motor is stopped.</p> <p>Applicable faults are shown: Warning: F47 SafetyReached, subcode: SQS (4). Warning: F48 SafetyViolat, Safety function: SMS, subcode: 2/3 (depending on the violated limit).</p> <p>NOTE! The faults that are shown and their type (Fault or Warning) depend on the settings of the AC drive.</p> <p>The drive is in NOT READY state or in RUN state.</p> <p>NOTE! In the SQS-SS2 mode the drive should stay in RUN state. In SQS-STO or SQS-SS1 mode the drive should be in NOT READY state.</p>	
9	<p>Deactivate the SMS function.</p> <p>Send a reset signal to the option board.</p> <p>NOTE! When a safety function is deactivated and the violation is reset, and there is a valid RUN request in the AC drive, the AC drive can start running unexpectedly.</p>	
10	Make sure that the drive is in READY state.	
11	When necessary, repeat the tests for the other direction.	

The SMS tests have been executed, possible deviations documented and testing approved.



Notes:

3.7.7 SSR

When possible, test the SQS safety function before the SSR safety function. Do the test steps for all the used SSR limits.

Step	Instructions	Comments
1	Make sure that the drive is in READY state. Make sure that no safety functions requested.	
2	Give a RUN request to the AC drive. The speed should be in the safe range between the SSR limit(s).	
3	Activate the SSR function from the desired source.	
4	A warning should occur to indicate the SSR function activation: Warning: F46 SafetyRequest, subcode: SSR (5). Warning: F47 SafetyReached, subcode: SSR (5). NOTE! The display of the warning depends on the settings of the AC drive. NOTE! Depending on SSR parameter values, the function may be reached after a delay. Once the function is Reached, the "request" warning should disappear.	
5	Increase the speed above the SSR limit.	
6	The SQS function becomes active once speed exceeds the limit and the SSR function detects the violation. Do a check that the violation occurs at the expected speed.	
7	Verify that the SQS function operates correctly and is suitable for the process. NOTE! The SQS function may be operating in the STO, SS1, or SS2 mode.	
8	Make sure that the motor is stopped. Applicable faults are shown: Warning: F47 SafetyReached, subcode: SQS (4). Warning: F48 SafetyViolat, Safety function: SSR, subcode: 7/8 (depending on the violated limit).	

	<p>NOTE! The faults that are shown and their type (Fault or Warning) depend on the settings of the AC drive.</p> <p>The drive is in NOT READY state or in RUN state.</p> <p>NOTE! In the SQS-SS2 mode the drive should stay in RUN state. In the SQS-STO or SQS-SS1 mode the drive should be in NOT READY state.</p>	
9	<p>Deactivate the SSR function.</p> <p>Send a reset signal to the option board.</p> <p>NOTE! When a safety function is deactivated and the violation is reset, and there is a valid RUN request in the AC drive, the AC drive can start running unexpectedly.</p>	
10	Make sure that the drive is in READY state.	
11	When necessary, repeat the tests for the other SSR limit.	

The SSR tests have been executed, possible deviations documented and testing approved.

Notes:

3.7.8 SSM

Step	Instructions	Comments
1	<p>Make sure that the drive is in READY state.</p> <p>Make sure that no safety functions requested.</p>	
2	Give a RUN request to the AC drive. The speed should be in the safe range between the SSM limits.	
3	Activate the SSM function from the desired source.	
4	<p>The SSM function activation should be detected by the external system that monitors the SSM output state.</p> <p>As default, there is no warning shown for the SSM function. The state of the function can also be verified from the expander board menu on the control panel of the AC drive.</p> <p>The SSM output is in state HIGH.</p>	

	NOTE! The display of warnings depends on the settings of the AC drive.	
5	Increase the speed above the reached SSM limit. When you are testing the SSM minimum limit, decrease the speed below the limit instead.	
6	Speed is outside the safe range. The SQS function is not active. The SSM output is in state LOW.	
7	Make sure that the reactions of the external system that monitors the SSM output were correct.	
8	Make the speed go back to the safe range.	
9	Speed is in the safe range. The SSM output is in state HIGH.	
10	Deactivate the SSM function. NOTE! If the SSM function is used in the "Always active" mode, you cannot do this step.	
11	If the manual acknowledgement is used: do a check that the SSM function is not deactivated automatically. Activate the acknowledgement from the desired source.	
12	The SSM function is deactivated. The SSM warnings are cleared on the drive. The SSM output is in state LOW.	
13	Make sure that the reactions of the external system that monitors the SSM output were correct.	
14	When necessary, re-execute the test for the other SSM limit (minimum or maximum).	

The SSM tests have been executed, possible deviations documented and testing approved.

Notes:

3.8 After commissioning

NOTE! The information in this chapter is also included in the Advanced safety options Operating Guide.

After the commissioning of the system with the option board, the parameter file stored in the option board can be validated.

Step	Instructions	Comments
1	Select "Validate" in the VACON® Safe tool.	
2	Fill in the validation data.	
3	Save the validation data to the option board.	
4	Reboot the AC drive. The warning on a not validated parameter file disappears.	

Make sure that the Commissioning report is filled correctly and archive it.

The system can be taken into use after these conditions are fulfilled:

- The AC drive is parameterised and commissioned.
- The commissioning of the option board is completed.
 - o The option board is parameterised.
 - o The used safety functions and features have been tested.
 - o The parameter file of the option board is validated.
- Other related subsystems have been correctly commissioned.
- Other safety-related systems that were modified or disabled for the commissioning are enabled or returned to the normal operation mode.

4 Signature

Type of testing:

- First commissioning
- Re-commissioning
- Periodic/maintenance test
- _____

Creation of the parameter file

Date: _____

Company: _____

Creator: _____

Parameterisation of the Advanced safety option board

Date: _____

Company: _____

Signature: _____

Validation of the Advanced safety option board as a part of the overall system has been executed

Date: _____

Company: _____

Signature: _____

ENGINEERING
TOMORROW

Danfoss

Danfoss Drives Oy
Runsorintie 7
FIN-65380 Vaasa
www.danfoss.com

Danfoss can accept no responsibility for possible errors in catalogs, brochures and other printed material. Danfoss reserves the right to alter its products without notice. This also applies to products already on order provided that such alterations can be made without subsequential changes being necessary in specifications already agreed. All trademarks in this material are property of the respective companies. Danfoss and the Danfoss logotype are trademarks of Danfoss A/S. All rights reserved.

