

Data sheet

DSP MOD@

**General description
and application**



District heating transfer stations provide the link between district heating suppliers and customers' systems. They incorporate the necessary equipment to tailor the supplied heat to the needs of the object premises as specified in the heating supply contract. In this they need to comply with all applicable standards and with the supplier's technical connection conditions. Indirect connections (in which district heating and in-house systems are hydraulically isolate) incorporate components to separate the systems (heat exchanger), to limit the flow volume to that specified in the contract, regulate the secondary supply temperature, and measure the energy consumption. The system described here is a standard type in which one different types of applications can be connected on the secondary.

**Maximum operating
parameters**

Primary		
Maximum permissible supply temperature, primary	TSP	120°C (PN16) - Heating / 50°C (PN16) - Cooling
Maximum permissible operating pressure, primary	PSP	14,4 bar(g) - Heating / 16 bar(g) - Cooling
Rated pressure, primary	PN	16
Maximum permissible pressure differential, primary	DPP	12 bar (PN16)
Maximum permissible flow volume, primary	VSP	71,4 m³/h for w ≤ 1,5 m/s
Secondary		
Maximum permissible supply temperature, secondary	TS	100 °C - Heating / 50°C (PN16) - Cooling
Maximum permissible operating pressure, secondary	PSS	10 bar(g)
Rated pressure, secondary	PN	16
Maximum permissible flow volume, secondary	VSS	71,4 m³/h for w ≤ 1,5 m/s

Circuit diagram

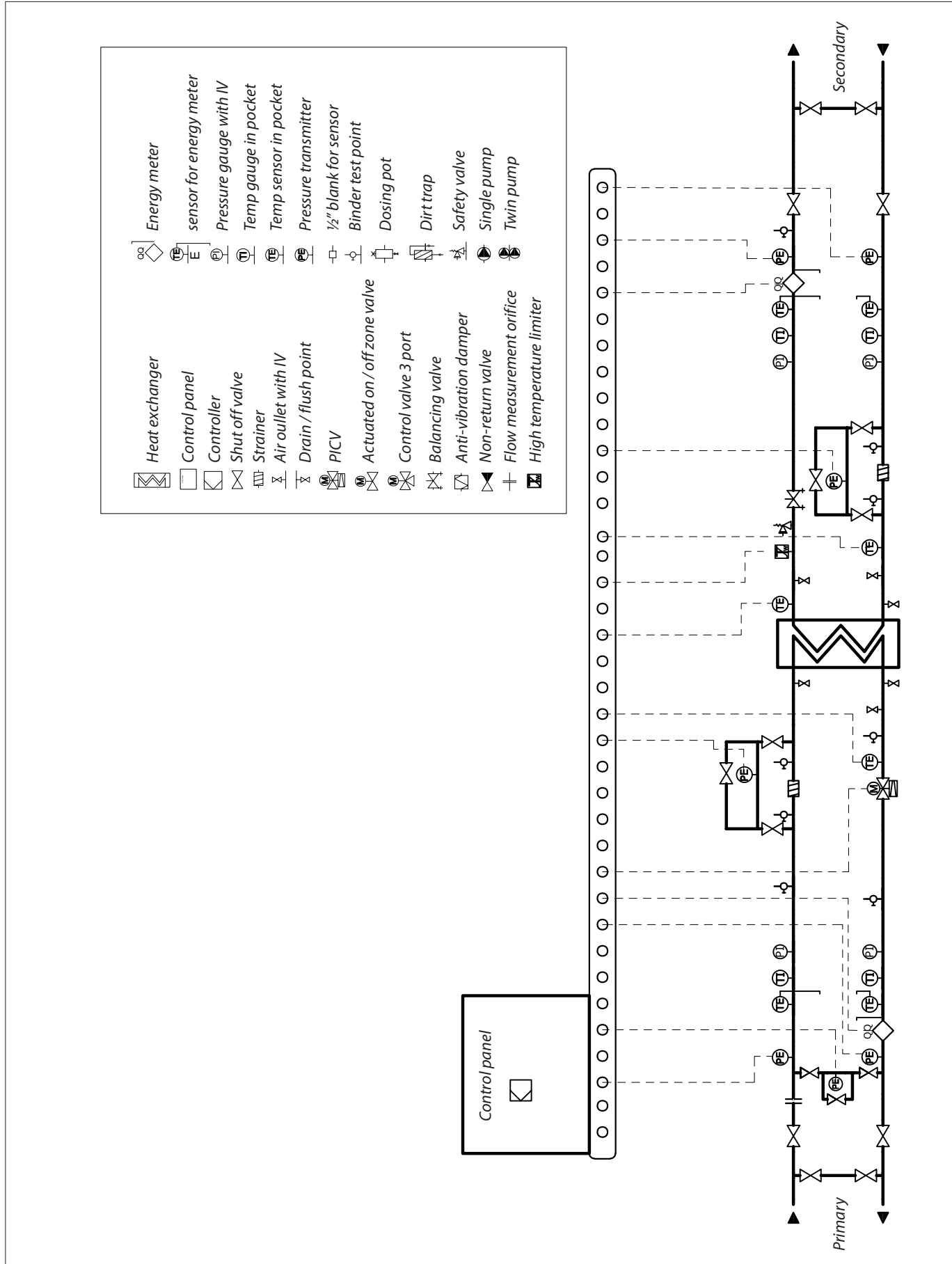

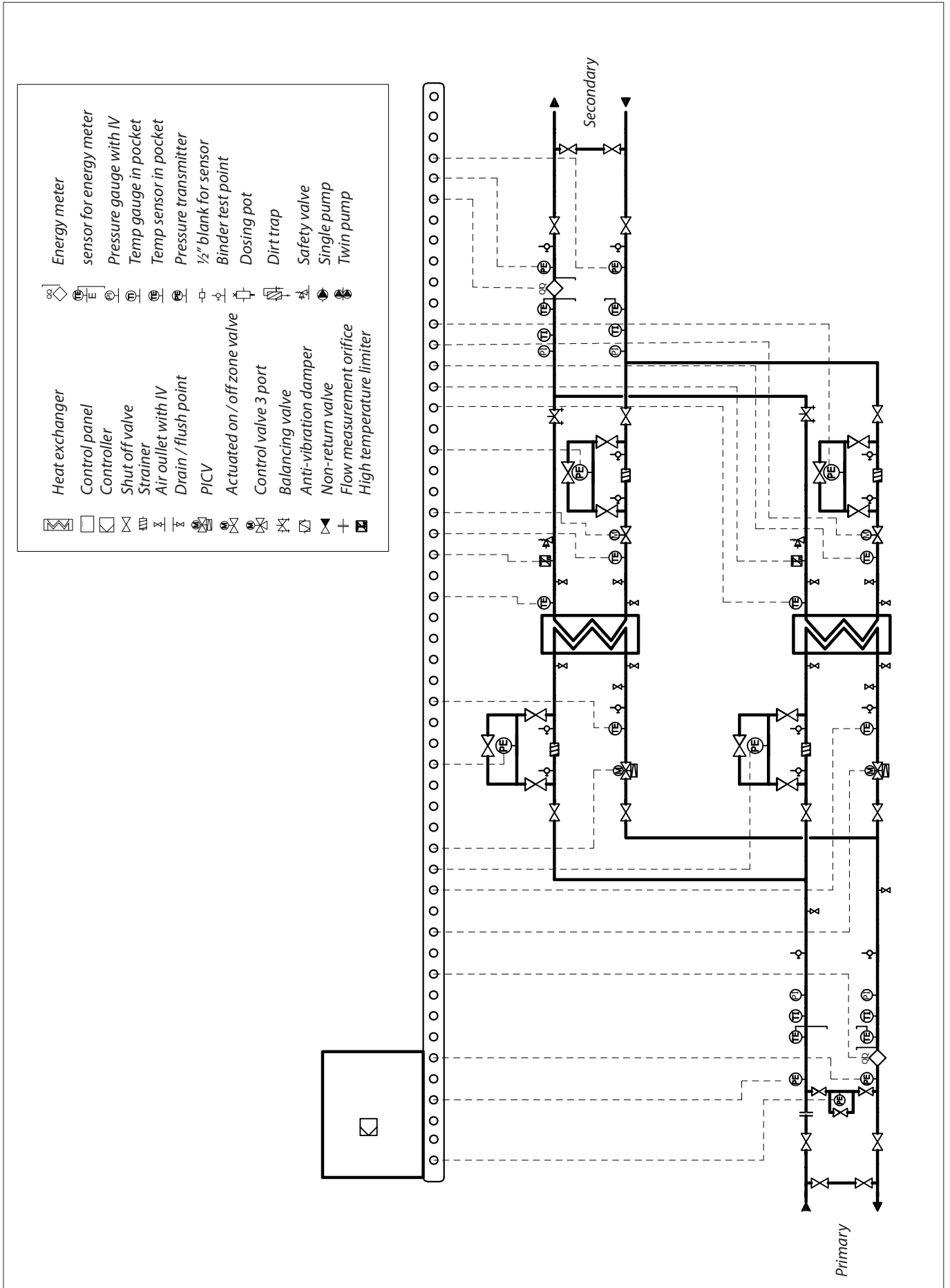

Materials

Pipes and flanges	P235GH-TC1, P245GH
Heat exchanger	AISI 304/316 and EPDM-HT, NBR-HT
Fittings	CW617N, EN-GJS-400-18-LT (GGG40.3)
Insulation	PUR, $\lambda = 0,022$ W/mK, EPP, $\lambda = 0,036$ W/mK

Function

Hot water drawn from the pipeline of the local or district heating supply company is fed into the station at an appropriate temperature and pressure, which may be higher in winter than in summer.

In the primary supply line this hot water will flow through a shut-off valve and a dirt trap / strainer. The supply and return lines will incorporate a thermometer and a manometer to register the temperature and pressure.

There will also be regulatory equipment in the return lines of the primary as specified by the circuit design.

The cooled heating water then flows back to the local or district heating supply company via the primary return pipe.

On secondary side different types of applications and systems can be connected.

Each substation is equipped with a flushing bypass for flushing the system and isolating the substation.

For flushing the heat exchanger use the connections next to it and isolate the substation from the system.

Each circuit on primary and secondary is equipped with pressure and temperature transmitters.

Each strainer is equipped with a differential pressure sensor.

There is a heat meter present on primary and secondary side of the substation.

All these can be used for actionable insights via Danfoss monitoring solution LeanHeat Monitor.

A differential pressure sensor is delivered with the substation connected on primary side. This can be used as hard wire input for controlling the district energy pumps.

All DSP MOD@ substations are equipped with a 4G router and an Ethernet switch.

You can chose to connect via sim or local Internet connection.

Types/designation

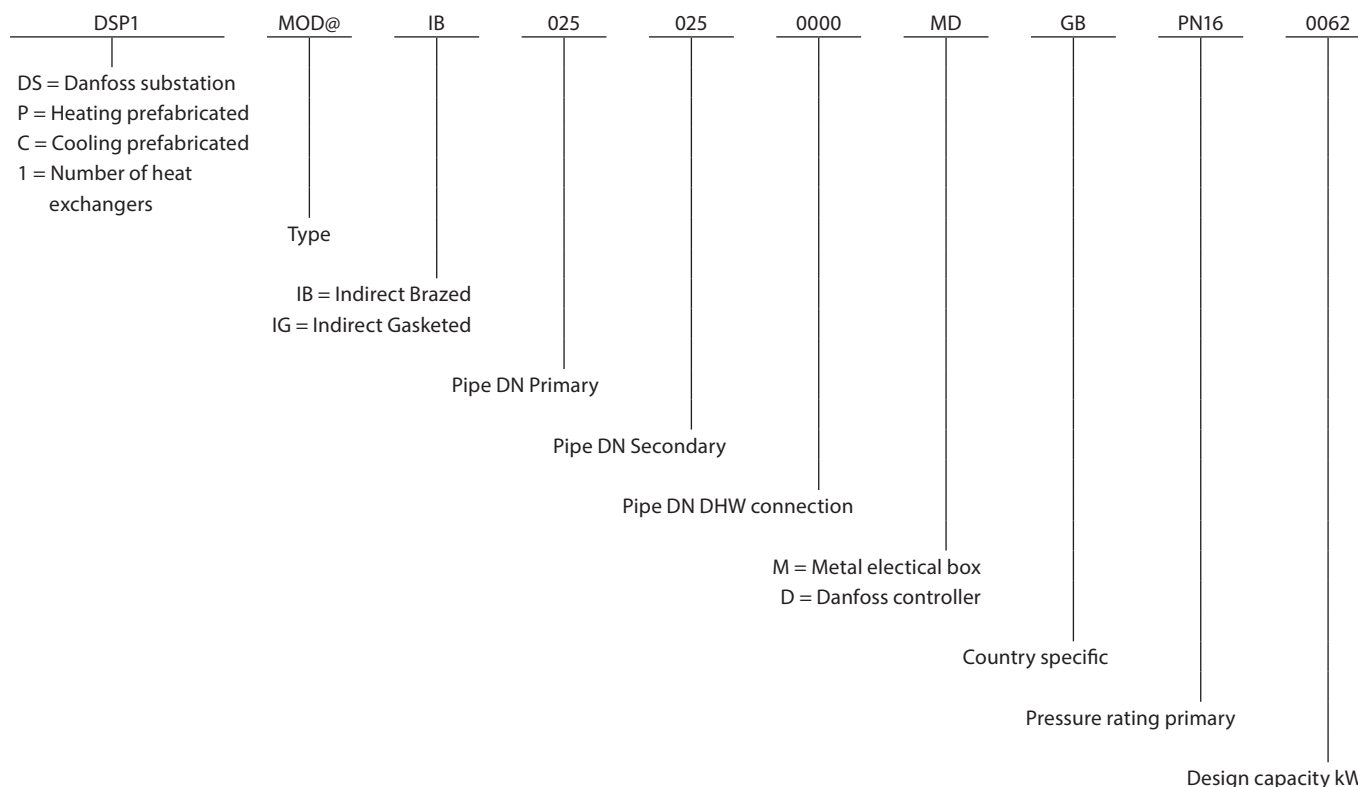

Technical data

No	SAP code	Standard code		Circuit		Module DN		Common DN		HEX	Maximum flow		PICV	Actuator	General dimensions					Splitting dimensions			Weight [kg]
		Description		1	2	Pri.	Sec.	Pri.	Sec.		Pri.	Sec.			[m³/h]	[m³/h]	Description	L	WF	HP	HS	W	
1	20080023	DSP1-MOD@-IB025-025-0000-MD-GB-PN16-0062		100%		25	25	25	25	XB37H-1-30	1,80	1,80	AVQM PN16 20/6,3	AME 23 24V	2020	590	1590	1715	790	1460	720	136	
2	20080024	DSP2-MOD@-IB025-025-0000-MD-GB-PN16-0037			60%	25	25	25	25	XB37H-1-20	1,08	1,08	AVQM PN16 20/6,3	AME 23 24V	2020	590	1585	1585	790	1590	720	258	
3	20080025	DSP2-MOD@-IB025-025-0000-MD-GB-PN16-0062		100%		25	25	25	25	XB37H-1-30	1,80	1,80	AVQM PN16 20/6,3	AME 23 24V	2020	590	1600	1735	790	1485	720	272	
4	20080026	DSP1-MOD@-IB032-032-0000-MD-GB-PN16-0128		100%		32	32	32	32	XB37H-1-60	3,72	3,72	AVQM PN16 25/8	AME 23 24V	2020	590	1630	1780	790	1500	720	153	
5	20080028	DSP2-MOD@-IB032-032-0000-MD-GB-PN16-0077			60%	25	25	32	32	XB37H-1-36	2,23	2,23	AVQM PN16 20/6,3	AME 23 24V	2020	590	1630	1780	835	1500	720	291	
6	20080029	DSP2-MOD@-IB032-032-0000-MD-GB-PN16-0128		100%		32	32	32	32	XB37H-1-60	3,72	3,72	AVQM PN16 25/8	AME 23 24V	2020	590	1600	1600	835	1500	720	306	
7	20080027	DSP1-MOD@-IB040-040-0000-MD-GB-PN16-0194		100%		40	40			XB37M-1-110	5,64	5,64	AVQM PN16 32/10	AME 23 24V	2020	590	1630	1780	790	1500	720	176	
8	20080030	DSP2-MOD@-IB040-040-0000-MD-GB-PN16-0116			60%	32	32	40	40	XB37H-1-60	3,39	3,39	AVQM PN16 32/10	AME 23 24V	2020	590	1660	1660	840	1625	720	334	
9	20080031	DSP2-MOD@-IB040-040-0000-MD-GB-PN16-0194		100%		40	40	40	40	XB37M-1-110	5,64	5,64	AVQM PN25 32/12,5	AME 23 24V	2020	590	1660	1660	840	1625	720	352	
10	20080032	DSP1-MOD@-IB050-050-0000-MD-GB-PN16-0360		100%		50	50			XB59M-1-90	10,47	10,47	AVQM PN25 50/25	AME 23 24V	2020	590	1790	1945	790	1470	720	317	
11	20080033	DSP2-MOD@-IB050-050-0000-MD-GB-PN16-0216			60%	40	40	50	50	XB59M-1-50	6,28	6,28	AVQM PN25 32/12,5	AME 23 24V	2020	590	1795	1795	840	1470	720	602	
12	20080034	DSP2-MOD@-IB050-050-0000-MD-GB-PN16-0360		100%		50	50	50	50	XB59M-1-90	10,47	10,47	AVQM PN25 50/25	AME 23 24V	2020	590	1795	1795	840	1470	720	634	
13	20080035	DSP1-MOD@-IB065-065-0000-MD-GB-PN16-0667		100%		65	65			XB59M-1-140	19,40	19,40	AFQM 2 PN16 65/60	AME 658 SD 24V	2390	790	1830	1955	840	1865	790	688	
14	20080036	DSP2-MOD@-IB065-065-0000-MD-GB-PN16-0400			60%	50	50	65	65	XB59M-1-90	11,64	11,64	AVQM PN25 50/25	AME 23 24V	2390	790	1895	1895	920	1865	790	1307	
15	20080037	DSP2-MOD@-IB065-065-0000-MD-GB-PN16-0667		100%		65	65	65	65	XB59M-1-140	19,40	19,40	AFQM 2 PN16 65/60	AME 658 SD 24V	2390	790	1895	1853	980	1985	790	1376	
16	20080038	DSP1-MOD@-IB080-080-0000-MD-GB-PN16-0991		100%		80	80			XB59M-1-200	26,73	26,73	AFQM 2 PN16 65/60	AME 658 SD 24V	2490	950	1900	2040	1080	1975	790	902	
17	20080039	DSP2-MOD@-IB080-080-0000-MD-GB-PN16-0551			60%	65	65	80	80	XB59M-1-140	16,04	16,04	AFQM 2 PN16 65/60	AME 658 SD 24V	2490	950	1935	1935	1040	1990	790	1714	
18	20080040	DSP2-MOD@-IB080-080-0000-MD-GB-PN16-0919		100%		80	80	80	80	XB59M-1-200	26,73	26,73	AFQM 2 PN16 65/60	AME 658 SD 24V	2490	950	1955	1955	1080	2090	790	1804	
19	20080041	DSP1-MOD@-IG100-100-0000-MD-GB-PN16-1586		100%		100	100			A455E-IG16-149-TMTL62	45,72	45,72	AFQM 2 PN16 100/160	AME 658 SD 24V	3990	1300	2190	2190	1400	2490	2000	1393	
20	20080042	DSP2-MOD@-IG100-100-0000-MD-GB-PN16-0952			60%	80	80	100	100	A19A-DG16-128-TMTL85	27,43	27,43	AFQM 2 PN16 80/80	AME 658 SD 24V	2850	950	2145	2145	1160	2175	1150	1800	
21	20080043	DSP2-MOD@-IG100-100-0000-MD-GB-PN16-1586			100%	100	100	100	100	A455E-IG16-149-TMTL62	45,72	45,72	AFQM 2 PN16 100/160	AME 658 SD 24V	3990	1300	2175	2175	1410	2490	2000	2786	
22	20080044	DSP1-MOD@-IG125-125-0000-MD-GB-PN16-2455		100%		125	125			A455E-IG16-235-TMTL58	71,41	71,41	AFQM 2 PN25 125/250	AME 658 SD 24V	3990	1300	2390	2390	1385	2500	2000	1702	
23	20080045	DSP2-MOD@-IG125-125-0000-MD-GB-PN16-1473			60%	100	100	125	125	A455E-IG16-138-TMTL62	42,84	42,84	AFQM 2 PN16 100/160	AME 658 SD 24V	3990	1300	2350	2350	1450	2500	2000	2806	
24	20080046	DSP2-MOD@-IG125-125-0000-MD-GB-PN16-2455		100%		125	125	125	125	A455E-IG16-235-TMTL58	71,41	71,41	AFQM 2 PN25 125/250	AME 658 SD 24V	3990	1300	2345	2345	1445	2500	2000	3404	

No	SAP code	Standard code	Circuit		Module DN		Common DN		HEX	Maximum flow		PICV	Actuator	General dimensions				Splitting dimensions			Weight [kg]
			1	2	Pri	Sec	Pri	Sec		Pri	Sec			L	WF	HP	HS	W	LM	LH	
1	200B0047	DSC1-MOD@-IB025-025-0000-MD-GB-PN16-0012	100%		25	25	25	25	XB37M-1-26	1,75	1,75	AVQM PN16 20/6,3	AME 23 24V	2020	590	1590	1715	790	1460	720	138
2	200B0048	DSC2-MOD@-IB025-025-0000-MD-GB-PN16-0007		60%	25	25	25	25	XB37M-1-16	1,05	1,05	AVQM PN16 20/6,3	AME 23 24V	2020	590	1585	1585	790	1590	720	262
3	200B0049	DSC2-MOD@-IB025-025-0000-MD-GB-PN16-0012	100%		25	25	25	25	XB37M-1-26	1,75	1,75	AVQM PN16 20/6,3	AME 23 24V	2020	590	1600	1735	790	1485	720	276
4	200B0050	DSC1-MOD@-IB032-032-0000-MD-GB-PN16-0026	100%		32	32	32	32	XB37M-1-50	3,78	3,78	AVQM PN16 25/8	AME 23 24V	2020	590	1630	1780	790	1500	720	153
5	200B0051	DSC2-MOD@-IB032-032-0000-MD-GB-PN16-0016	60%		25	25	32	32	XB37M-1-30 PN25	2,27	2,27	AVQM PN16 20/6,3	AME 23 24V	2020	590	1630	1780	835	1500	720	291
6	200B0052	DSC2-MOD@-IB032-032-0000-MD-GB-PN16-0026	100%		32	32	32	32	XB37M-1-50 PN25	3,78	3,78	AVQM PN16 25/8	AME 23 24V	2020	590	1600	1600	835	1500	720	306
7	200B0053	DSC1-MOD@-IB040-040-0000-MD-GB-PN16-0039	100%		40	40	40	40	XB37M-1-90 PN25	5,67	5,67	AVQM PN16 32/10	AME 23 24V	2020	590	1630	1780	790	1500	720	176
8	200B0054	DSC2-MOD@-IB040-040-0000-MD-GB-PN16-0023	60%		32	32	40	40	XB37M-1-50	3,40	3,40	AVQM PN16 32/10	AME 23 24V	2020	590	1660	1660	840	1625	720	291
9	200B0055	DSC2-MOD@-IB040-040-0000-MD-GB-PN16-0039	100%		40	40	40	40	XB37M-1-90	5,67	5,67	AVQM PN16 32/10	AME 23 24V	2020	590	1660	1660	840	1625	720	306
10	200B0056	DSC1-MOD@-IB050-050-0000-MD-GB-PN16-0072	100%		50	50	50	50	XB59M-1-90	10,47	10,47	AVQM PN25 50/25	AME 23 24V	2020	590	1790	1945	790	1470	720	317
11	200B0057	DSC2-MOD@-IB050-050-0000-MD-GB-PN16-0043	60%		40	40	50	50	XB37L-1-120	6,28	6,28	AVQM PN25 40/16	AME 23 24V	2020	590	1795	1795	840	1470	720	602
12	200B0058	DSC2-MOD@-IB050-050-0000-MD-GB-PN16-0072	100%		50	50	50	50	XB59M-1-90	10,47	10,47	AVQM PN25 50/25	AME 23 24V	2020	590	1795	1795	840	1470	720	634
13	200B0059	DSC1-MOD@-IB065-065-0000-MD-GB-PN16-0133	100%		65	65	65	65	XB59M-1-180	19,34	19,34	AFQM 2 PN16 65/60	AME 658 SD 24V	2390	790	1830	1955	840	1865	790	688
14	200B0060	DSC2-MOD@-IB065-065-0000-MD-GB-PN16-0080	60%		50	50	65	65	XB59M-1-100	11,61	11,61	AVQM PN25 50/25	AME 23 24V	2390	790	1895	1895	925	1865	790	1307
15	200B0061	DSC2-MOD@-IB065-065-0000-MD-GB-PN16-0133	100%		65	65	65	65	XB59M-1-180	19,34	19,34	AFQM 2 PN16 65/60	AME 658 SD 24V	2390	790	1895	1895	980	1985	790	1376
16	200B0062	DSC1-MOD@-IG080-080-0000-MD-GB-PN16-0184	100%		80	80			A19A-DG16-96-TMTL77	26,76	26,76	AFQM 2 PN16 65/60	AME 658 SD 24V	2490	950	1900	2040	1080	1975	790	684
17	200B0063	DSC2-MOD@-IB080-080-0000-MD-GB-PN16-0110	60%		65	65	80	80	XB59M-1-120	16,06	16,06	AFQM 2 PN16 65/60	AME 658 SD 24V	2490	950	1935	1935	1040	1990	790	1612
18	200B0064	DSC2-MOD@-IG080-080-0000-MD-GB-PN16-0184	100%		80	80	80	80	A19A-DG16-96-TMTL77	26,76	26,76	AFQM 2 PN16 65/60	AME 658 SD 24V	2490	950	1955	1955	1080	2090	790	1368
19	200B0065	DSC1-MOD@-IG100-100-0000-MD-GB-PN16-0317	100%		100	100			A45SE-IG16-116-TKTM85	46,10	46,10	AFQM 2 PN16 100/160	AME 658 SD 24V	3990	1300	2190	2190	1400	2490	2000	1334
20	200B0066	DSC2-MOD@-IG100-100-0000-MD-GB-PN16-0190	60%		80	80	100	100	A19A-DG16-128-TMTL85	27,66	27,66	AFQM 2 PN16 80/80	AME 658 SD 24V	2850	950	2145	2145	1160	2175	1150	1741
21	200B0067	DSC2-MOD@-IG100-100-0000-MD-GB-PN16-0370	100%		100	100	100	100	A45SE-IG16-116-TKTM85	46,10	46,10	AFQM 2 PN16 100/160	AME 658 SD 24V	3990	1300	2175	2175	1410	2490	2000	2668
22	200B0068	DSC1-MOD@-IG125-125-0000-MD-GB-PN16-0491	100%		125	125	125	125	A45SE-IG16-187-TKTM80	71,41	71,41	AFQM 2 PN25 125/250	AME 658 SD 24V	3990	1300	2390	2390	1385	2500	2000	1639
23	200B0069	DSC2-MOD@-IG125-125-0000-MD-GB-PN16-0295	60%		100	100	125	125	A45SE-IG16-107-TKTM86	42,84	42,84	AFQM 2 PN16 100/160	AME 658 SD 24V	3990	1300	2350	2350	1450	2500	2000	2732
24	200B0070	DSC2-MOD@-IG125-125-0000-MD-GB-PN16-0491	100%		125	125	125	125	A45SE-IG16-187-TKTM80	71,41	71,41	AFQM 2 PN25 125/250	AME 658 SD 24V	3990	1300	2345	2345	1445	2500	2000	3278

The DSP MOD@ substation may be delivered in different configurations which can be defined. Please contact local sales representative. Please note that the Weight is calculated dry!

Dimensions

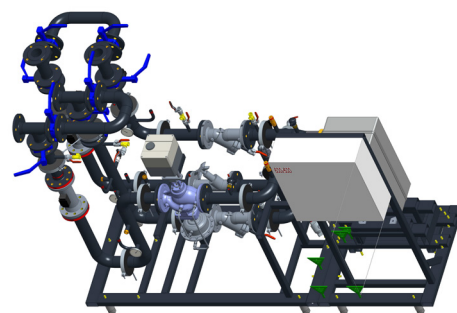
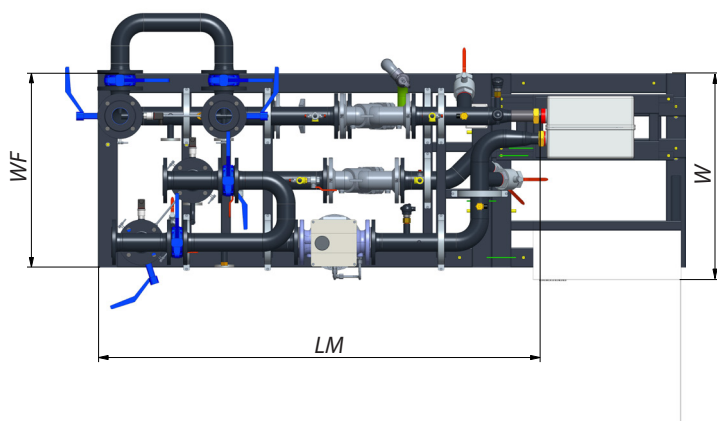
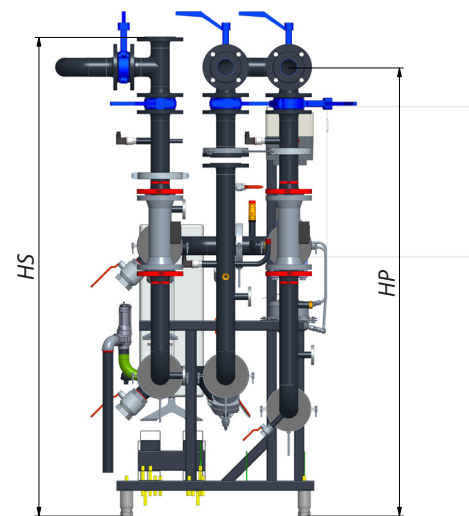
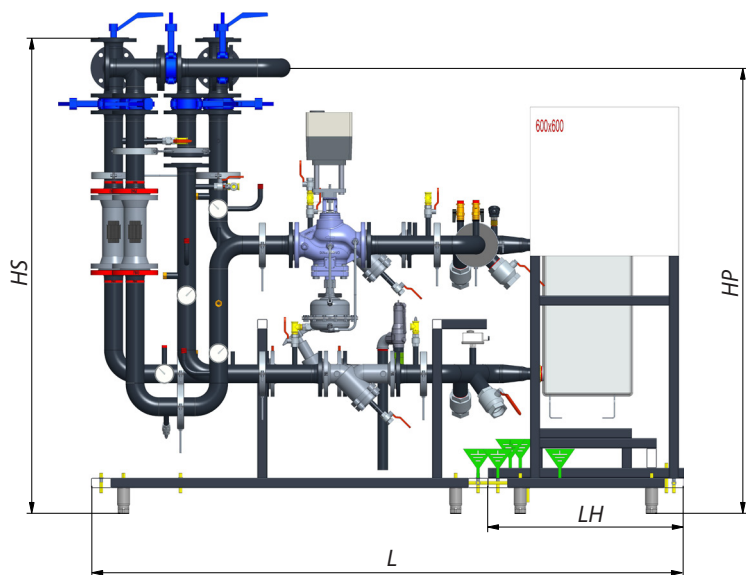

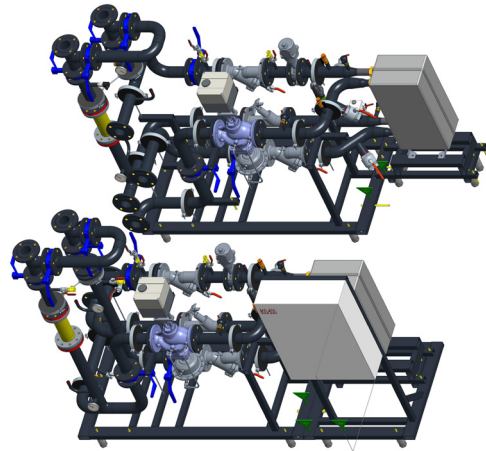
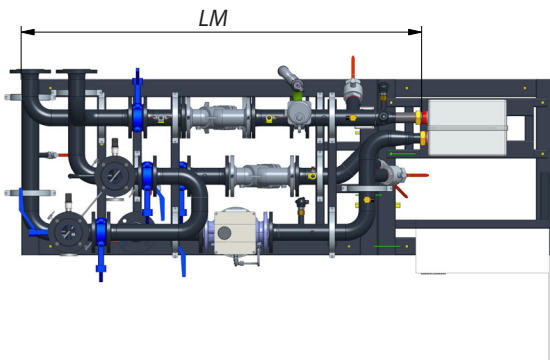
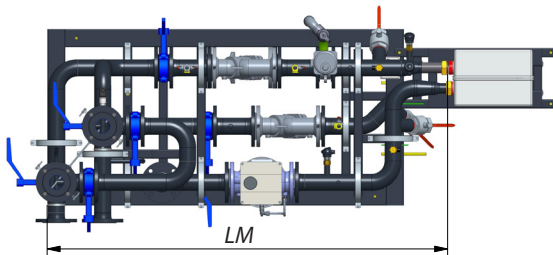
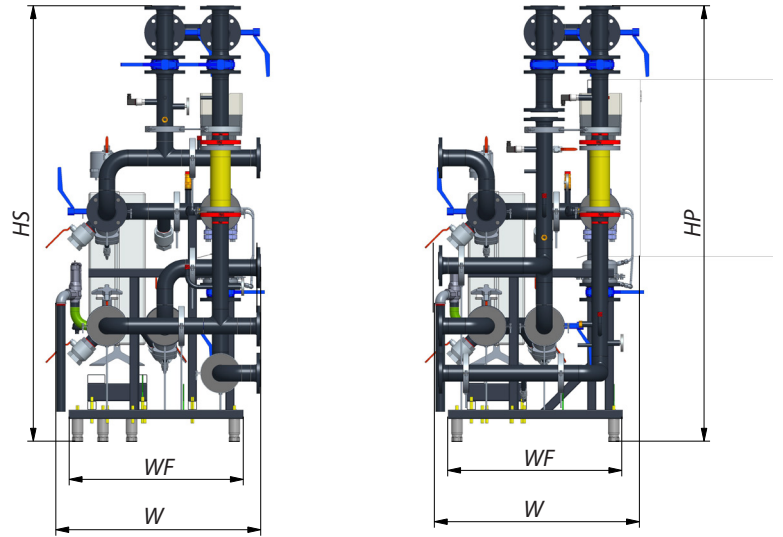
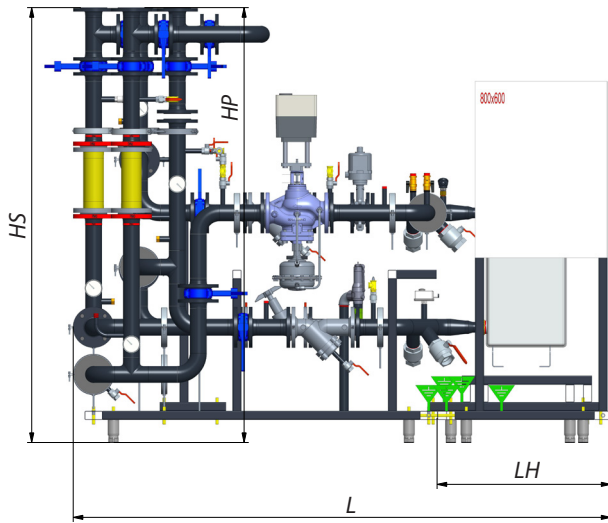

Connection possibilities

Connection left

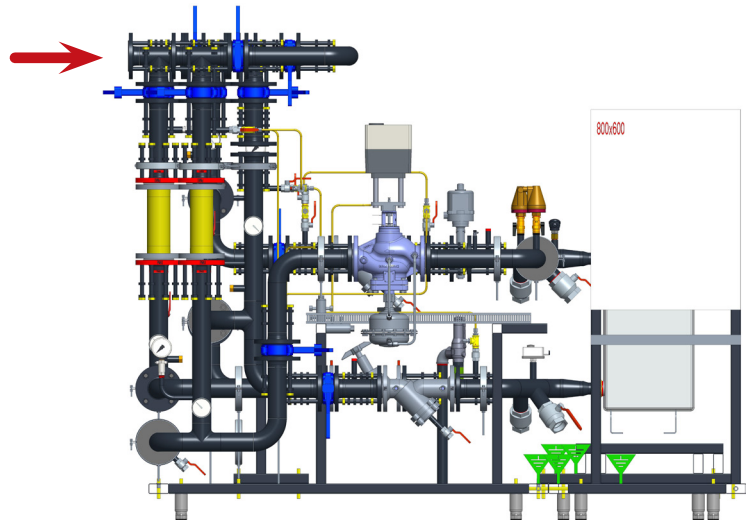

Connection right

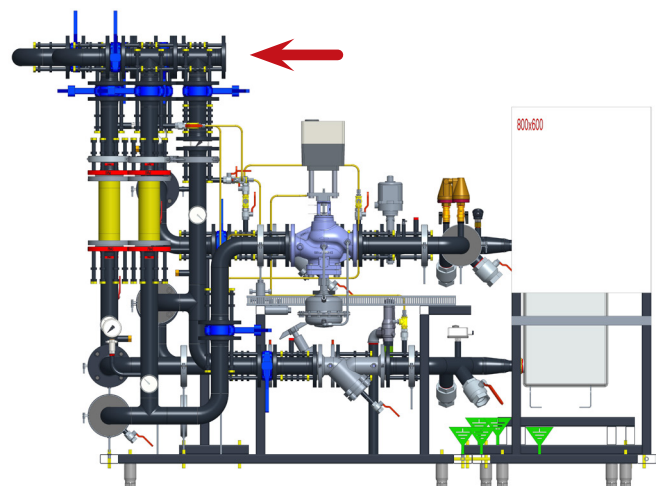

Connection up *

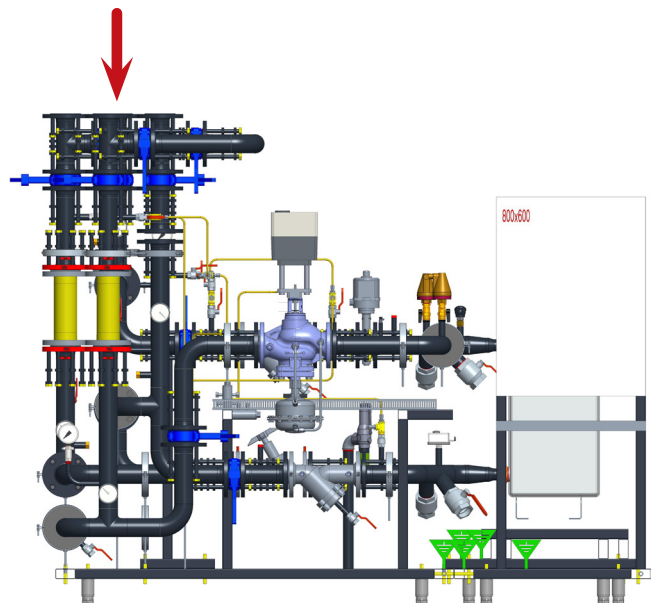

*II-parallel connection ***

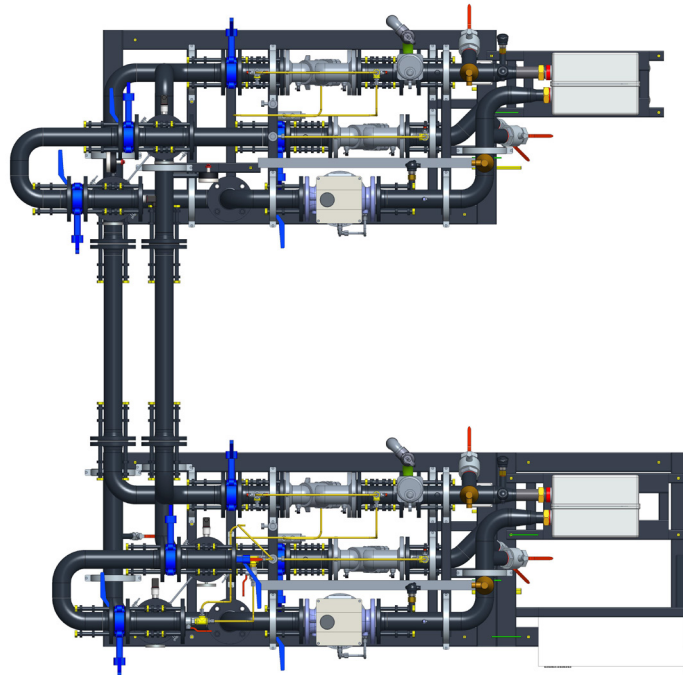

L-connection

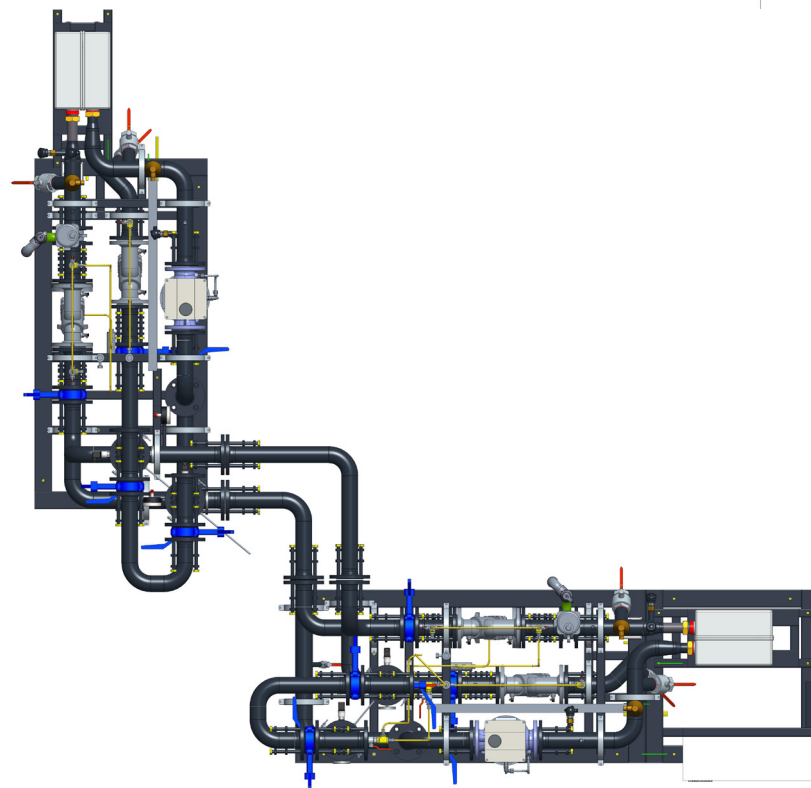

** in standard configuration the connections are orientated upwards*

*** in standard configuration parallel connection pipes (800 mm) are delivered with the substation*

Electrical connection for single heat exchanger substation

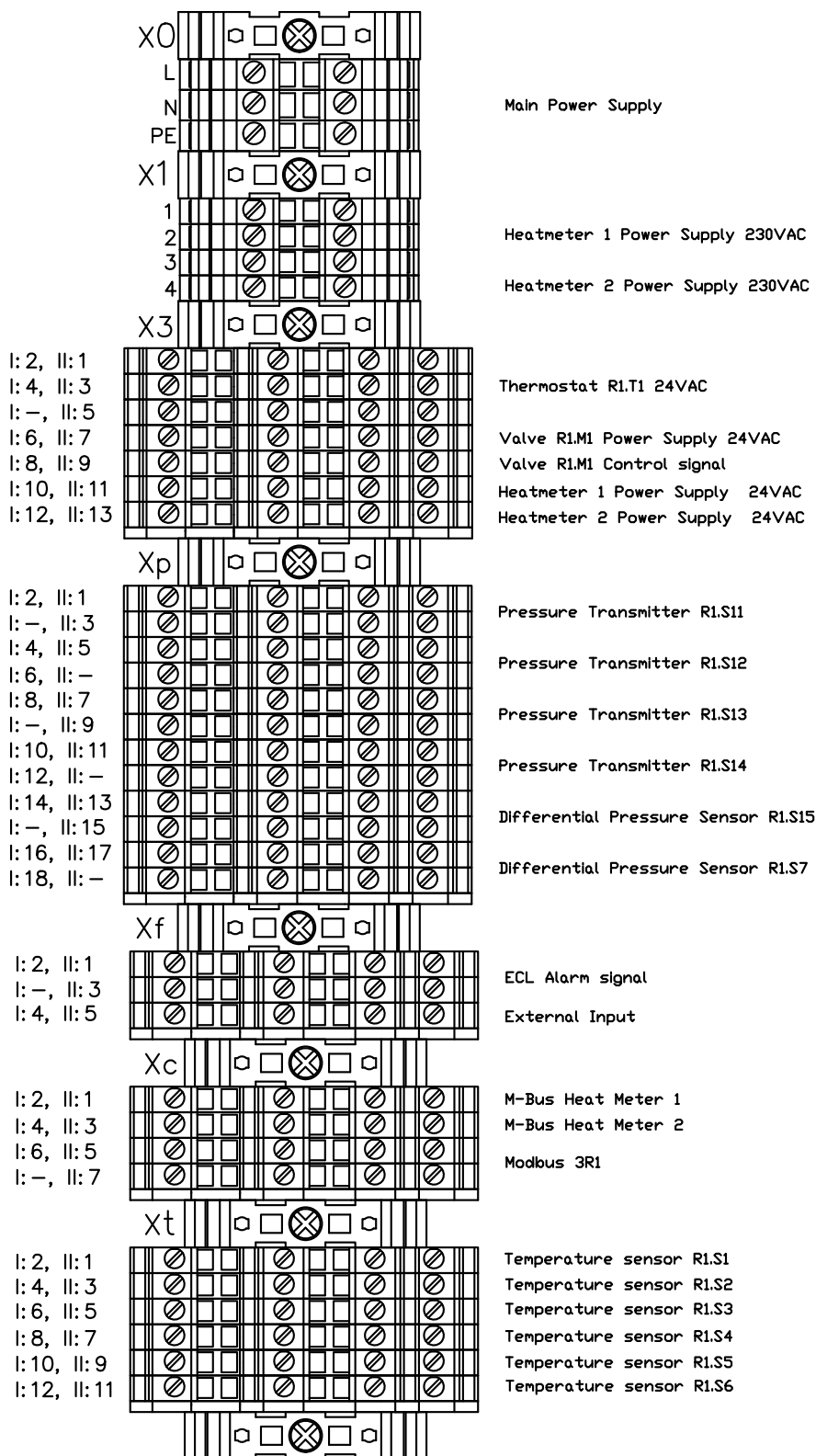

Notes (Uwagi):

X1 - HM power supply 230Vac
Zasilanie liczników 230Vac

X3 - 24Vac actuator/thermostat/heatmeter as option
Zasilanie 24Vac siłowniki, termostat, liczniki ciepła opcjonalnie

Xp - 0-10V pressure sensors
Przetworniki ciśnienia 0-10V

Xf - potential free
Sygnaly bezpotencjalowe

Xc - communication
Komunikacja

Xt - Temp sensors Pt1000
Czujniki temperatury Pt1000

Electrical connection for single heat exchanger substation

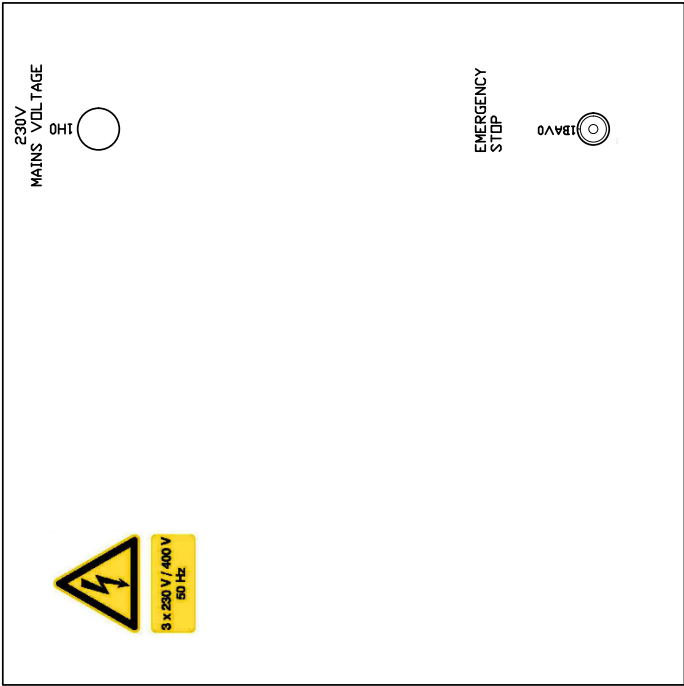
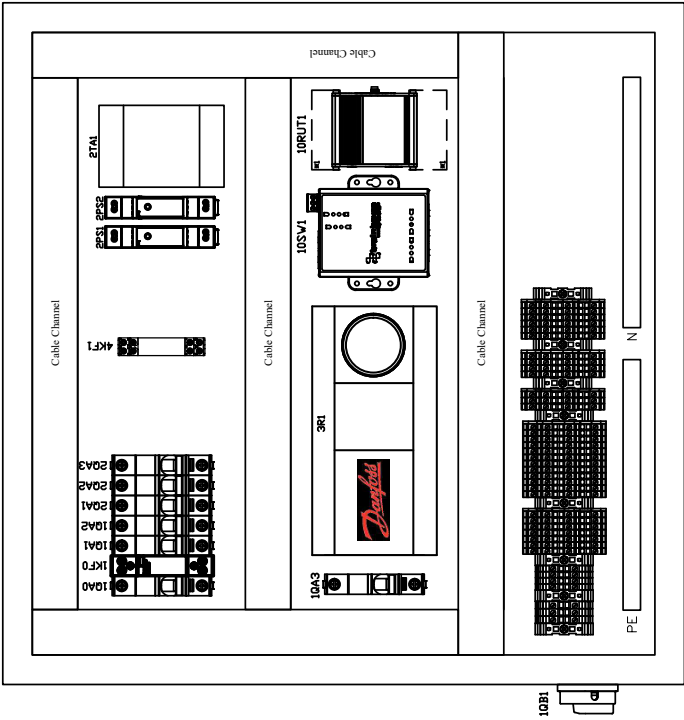

EBOX 600x600x200mm

Electrical connection for double heat exchanger substation

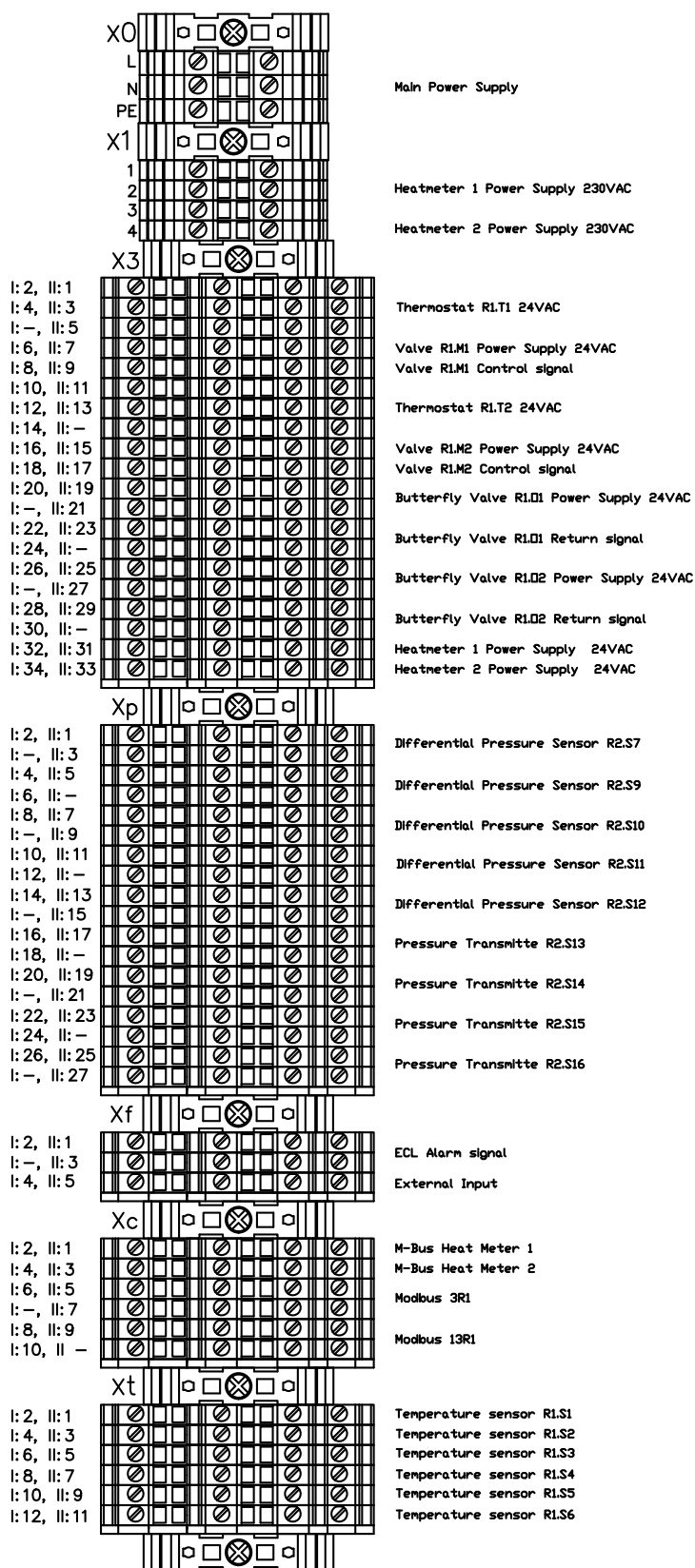

Notes (Uwagi):

X1 - HM power supply 230Vac
Zasilanie liczników 230Vac

X3 - 24Vac actuator/thermostat/heatmeter as option
Zasilanie 24Vac siłowniki, termostaty, liczniki ciepła opcjonalnie

Xp - 0-10V pressure sensors
Przetworniki ciśnienia 0-10V

Xf - potential free
Sygnały bezpotencjalowe

Xc - communication
Komunikacja

Xt - Temp sensors Pt1000
Czujniki temperatury Pt1000

Electrical connection for double heat exchanger substation

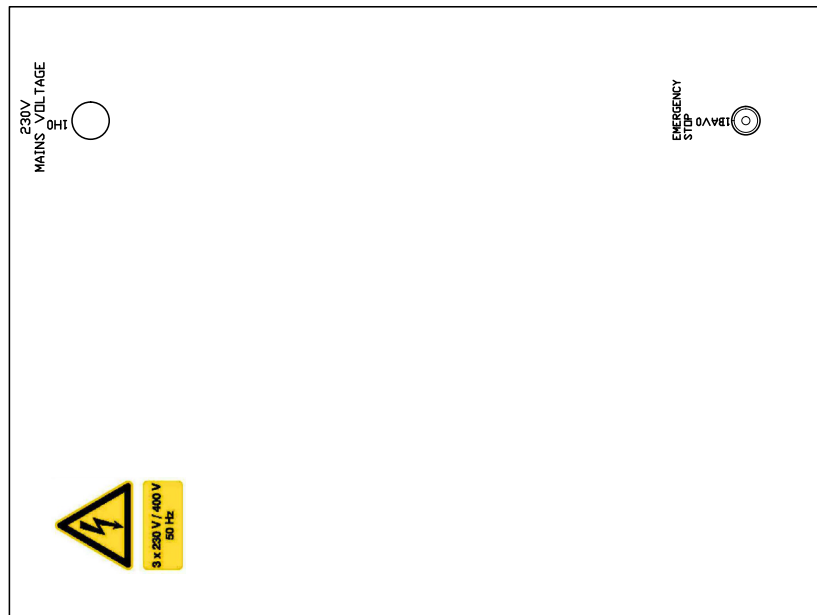
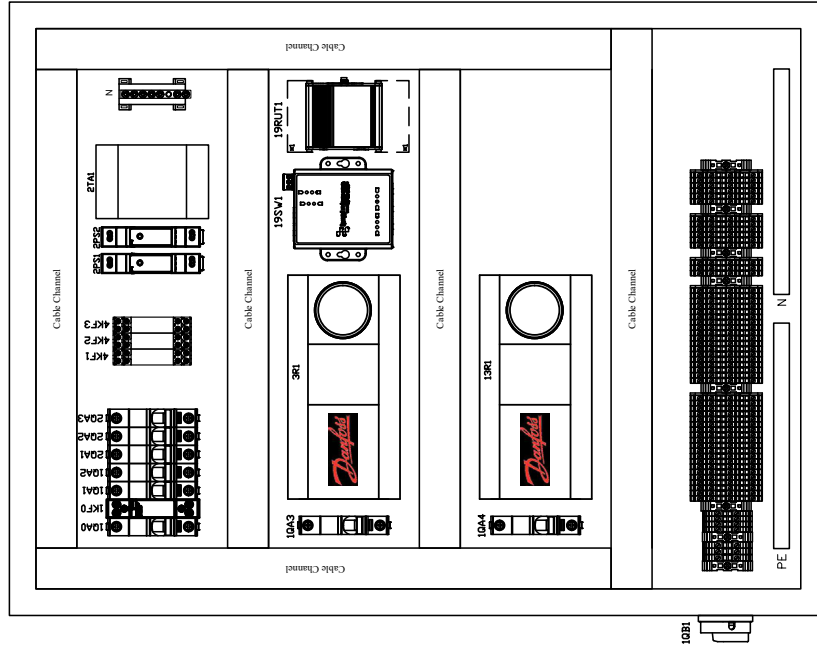

E.BDX 800x600x200mm



Danfoss A/S

Climate Solutions • danfoss.com • +45 7488 2222

Any information, including, but not limited to information on selection of product, its application or use, product design, weight, dimensions, capacity or any other technical data in product manuals, catalogues descriptions, advertisements, etc. and whether made available in writing, orally, electronically, online or via download, shall be considered informative, and is only binding if and to the extent, explicit reference is made in a quotation or order confirmation. Danfoss cannot accept any responsibility for possible errors in catalogues, brochures, videos and other material. Danfoss reserves the right to alter its products without notice. This also applies to products ordered but not delivered provided that such alterations can be made without changes to form, fit or function of the product.

All trademarks in this material are property of Danfoss A/S or Danfoss group companies. Danfoss and the Danfoss logo are trademarks of Danfoss A/S. All rights reserved.