

Data sheet

Disinfection Process Control & Temperature Registration CCR2+ Control

Features



Fig. 1 CCR2+ Disinfection Process Control & Temperature Registration

The CCR2+ is a controller used for optimising the thermal disinfection process in hot water systems with functions such as temperature registration and/or monitoring circulation hot water systems.

The CCR2+ can be applied independently, only for temperature registration in circulation hot water systems.

Thermal disinfection is one of the most effective physical methods for bacteria pasteurisation (*Legionella pneumophila*).

By optimising the thermal disinfection process, the energy consumption and the disinfection time are reduced.

By thermal disinfection the risk of bacteria contamination in hot water systems can be reduced significantly.

By temperature registration, the correct temperature level in the hot water circulation system can be controlled continuously and data can be stored for later reference.

Disinfection temperature and time can be adjusted:

- Disinfection temperatures from 50 °C to 78 °C;
- Disinfection time for the individual riser within in the range: minimum to maximum. Minimum required time is recommended based on Brundrett resources and related to temperature and is automatically limited by producer. It cannot be adjusted below and above the recommended values.

The CCR2+ incorporates LED status indicator, build in Web-Server App, Wi-Fi connection and LAN port, which allow the user to manually set and monitor measured parameters from the system on smart device or PC.

In addition, the CCR2+ also incorporates build in memory to store temperature data.

The system monitoring function is based on temperature registration and storage of data in the memory.

The storage rate (frequency of temperature sampling) can be adjusted by the user via the CCR2+ settings menu.

Data can be copied and processed in excel files (table, charts, graphs, etc.). All storage data are recorded based on special algorithms, which allow indication of genuine of stored data! The sampling rate can be defined from the menu within the range: minimum 1min. The sampling rate has significant influence on period of data storage.

From a technical point of view, the CCR2+ can control any number of risers due to the possibility of parallel and sequence connections.

One unit of the CCR2+ can control 20 risers equipped with thermo actuators type TWA-A and PT1000 sensors (S1 ... S20), plus one PT 1000 sensor (S0) in the supply pipe. The S0 sensor is used for initiating the disinfection process (fig. 3) or for registrating the supply temperature (Fig. 2) (Fig. 4 wiring scheme: S0 input). The S0 sensor is included in the package.

Additional functions:

- LED status indicators
- Build in web server for access via mobile devices or PC
- Alarm output;
- Pump protection function (cavitations in case of closing all valves);
- Indication of state of disinfection process realisation.
- System expansion via CCR+ Slave Unit (+16 risers)

The CCR2+ power supply ~24 V (DC), 50 Hz and output control of actuators 24 V.

Installation: on standard DIN relay.

Note: transformer is not included.

Recommended transformer: 150 VA, 24 V DC.

It is possible to connect CCR2+ to BMS system via RS 485 in standard Fbus or ModBus RTU or IP Modbus.

See the instructions for details.

CCR2+ System expansion

The system can also be expanded. For systems up to 36 risers/loops CCR2+ system can be expanded. With CCR+ Slave Unit, connected to CCR2+ Controller (master), system can be expanded with additional 16 risers/loops: 20 (CCR2+) + 16 (CCR+ Slave).

Very big systems (with more than 37) risers/loops can be expanded with several CCR2+ Controllers (with connected CCR+ Slave Unit on each master), which are connected (see instructions):

- by parallel connection CCR2+ (with Slave Unit) to another CCR2+ (with Slave Unit):
 - with one S0 sensor or
 - with individual S0 sensor for each CCR2+ (with Slave Unit);
- by sequence connection CCR2+ (with Slave Unit) to another CCR2+ (with Slave Unit):
 - with one S0 sensor or
 - with individual S0 sensor for each CCR2+ (with Slave Unit).

This function offers control and registration of temperatures in extensive installations with a big number of risers, e.g.: installation with 108 risers/loops require 3 CCR2+ Controllers, with connected CCR+ Slave Unit on each (3 x 20 + 3 x 16 = 108).

The type of combination after connection (see instruction of CCR2+) should be selected from the device menu settings. The correct combination of connection allows optimisation of the total time required for the disinfection process. For thermal disinfection CCR2+ can work in two applications:

- As Independent control, (S0 remote sensor connected)
No connection with heat source (boiler, sub-station, hot water tank, etc.)
Not fully automatic process. The total disinfection time for the total installation should be specified by maintenance service, and after the disinfection process, the supply temperature should be reduced manually to comfort temperature.
- As Dependent control, (S0 remote sensor connected and additional connection with weather compensator (e.g. ECL Comfort), boiler control or hot water tank - in this case, thermal disinfection can be performed in a fully automatic way. Moreover, a second application is not required to specify the total disinfection time for total installation as the CCR2+ after finishing the thermal disinfection in the last riser automatically returns to comfort temperature by sending signal (from output O3) to weather or boiler control (free contact relay required).

Applications

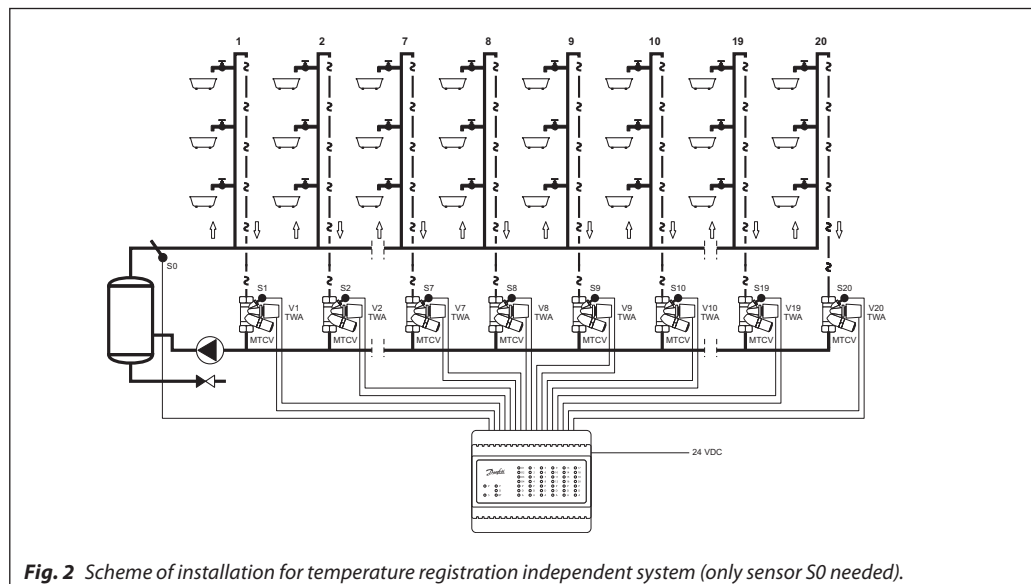

Fig. 2 Scheme of installation for temperature registration independent system (only sensor S0 needed).

Applications (continuous)

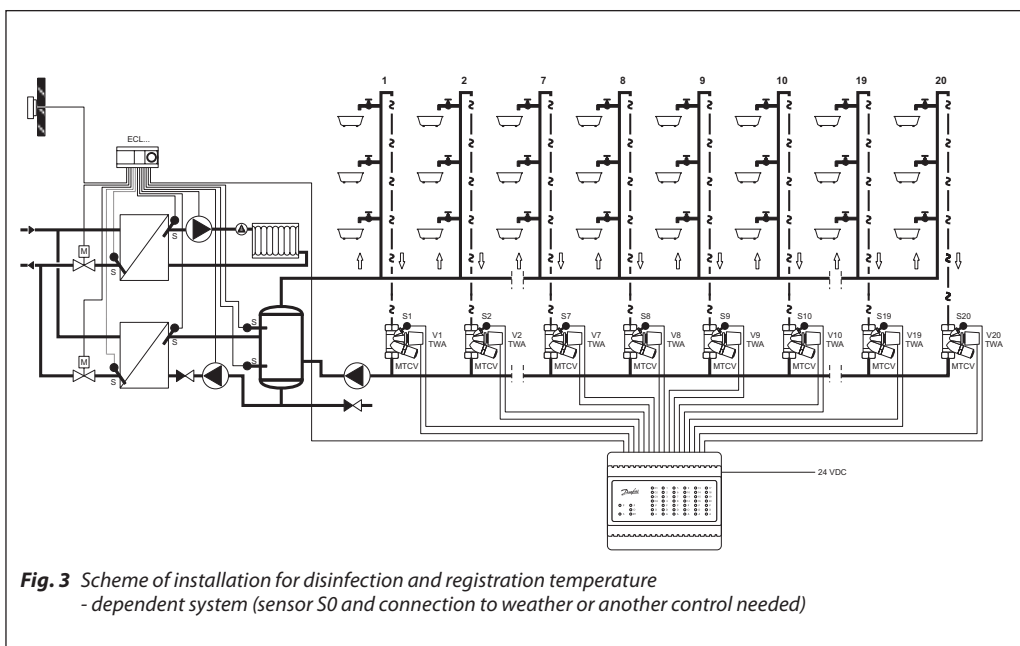

Fig. 3 Scheme of installation for disinfection and registration temperature - dependent system (sensor S0 and connection to weather or another control needed)

* ESMC sensor S0 is included with CCR2+ Controller

Ordering

Inclusive in the box CCR2+ Controller, 1 pcs ESMC sensor

Type	Designation	Supply voltage	Actuator type/nos.	Code No.
CCR2+ Controller	Disinfection Process Control Temperature registration	24 V DC	NC / 20	003Z3851

Accessory

Type	Designation	Voltage (currentless)	Comments	Data sheet number	Code No.
TWA-A	Thermal actuators	24 V	NC	VD.SA.P4.02	088H3110
TWA-A / ESMB	Thermal actuators with temperature sensors ESMB	24 V	NC	VD.SA.P4.02	003Z1043
Adapter	Adapter for TWA-A actuators for MTCV	-	for valve DN15 / DN20	VD.57.Y5.02	003Z1022
Socket	Socket for temperature sensor to MTCV	-	for type ESMB	VD.57.Y5.02	003Z1024
ESMB	Universal temperature sensor , PT1000	-	with 2.5 m cable	VD.74.I7.02	087B1184
ESMC	Surface Sensor, PT1000	-	with 2 m cable	VD.74.I7.02	087N0011
CCR+ Slave Unit	system expansion (add 16 risers)	24 V DC	-	-	003Z3852

Technical data

Temperature sensor (S0, S1-S20 / S21-36)	Pt1000, S0- type ESMC / ESM11, S1 ... S36 – type ESMB
Temperature range (registration)	-20 °C ... +120 °C
Measuring accuracy	± 0,1 K
Inputs: B1, B2 and B3	Free contact (5 V 1 mA)
Number of control valves (risers)	20 basic, additional 16 with system extension via CCR+ Slave Unit
Output signal to actuators	24 VDC max. 1 A
Alarm signal output	24 VDC max. 1 A
Relay output	0 ... 24 DC max. 1 A
Type of memory	Build-In
Capacity of memory	8 GB
Timer: Real time clock	Built-in battery - service life 10 years
Communication interfaces	- Wi-Fi (communication port only) - TPC/IP port (LAN cable connection) - Modbus RS485 RTU - IP Modbus (LAN cable connection)
Default IP settings	- Default LAN IP address (static): 192.168.1.100 - Default WiFi access IP address (static): 192.168.1.10 - IP address mask: 255.255.255.0 - Gateway address: 192.168.1.1 - DNS address: 192.168.1.1 - CCR name: ccrplus - default password: admin1234
Ambient temperature	0 ... 50 °C
Transport temperature	-10 ... +60 °C
IP rating	IP 20,
Power supply	24 VDC
Power consumption (Master controller only) ¹⁾	10 VA
Power consumption (Slave Unit only) ¹⁾	2 VA
Weight	0.3 kg
Installation	DIN rail 35 mm

¹⁾ To select proper power transformer please follow formula: 24 V 10VA (controller) + 7 VA*/per each actuator

Function

After installation all settings should be carried out on the CCR2+ according to the instructions in the device settings menu. User need to connect to CCR2+ with smarth device or PC.

Temperature registration

The CCR2+ can be used to record temperatures in a hot water circulation system. Temperatures are measured by PT 1000 temperature sensors installed in MTCV valves. If the CCR2+ is used solely for recording temperatures, it is not necessary to install any actuators on the MTCV valves.

Sampling time (data collection) intervals can be adjusted using the control's keypad from 1 minute.

Data are stored on internal memory. The data collecting period depends strongly on and the sampling interval.

Data are saved in *.csv format and can be downloaded any time in Data menu.

The data can be visualised in spreadsheet and graphs.

The disinfecting procedure

- **Start of disinfection**

The start of the disinfection process depends on the temperature signal from the temperature sensor S0 installed on the supply pipe of hot water systems or short cut input B1 (Fig. 4, wiring).

The increased S0 temperature initiates the thermal disinfection process when the average long-term supply temperature (from the last 5 minutes) exceeds the set disinfection temperature. After the disinfection process, the CCR2+ activates all thermo actuators (TWA-A) that opens all MTCV valves.

Start and progress of the disinfection process are indicated on device setting menu. It is possible to use outputs (Fig. 4) to indicate any external operation of the disinfection process, e.g.: heat force, alarm output.

- **The thermal disinfection process**

When the temperature of the circulation water has achieved the set value (S1 ... S20, the disinfection temperature has to be defined in device settings before the process starts), the CCR2+ starts to countdown the required disinfection time for each sensor S1 ... S20.

During the disinfection, the temperature in the risers is controlled by MTCV + TWA-A through control opening of MTCV by-pass, temperature is kept on a constant level, above (+1K) the minimum required disinfection temperature.

Pulse Wide Modulation (PWM) functions are used as TWA-A is thermo actuator. This solution can provide a very stable regulation with very low temperature oscillation. Because the TWA-A is a thermal actuator, its aperture is controlled by temporarily switching the actuator on and off with appropriate fill percentage (PWM-pulse wide modulation).

If the temperature in the riser is too low, the pulses switching the actuator on become longer and the intervals become shorter. If extending the switch-on pulses does not result in increasing the temperature, they will be extended even more, and the intervals will be shortened, right up to the point where constant voltage is fed to the actuator with no intervals in the switched-on state.

If the temperature in the riser is too high, the pulses switching the actuator on become shorter and the gaps become longer. If shortening the switch-on pulses does not result in an reduction of the temperature, the pulses will be shortened even more, and the intervals will be lengthened, right up to the point where the actuator is completely switched off and the valve closed. This procedure ensures that the riser is

protected from excessive and insufficient temperatures, even though a two-state motor is used. In order for the described process to work correctly (without oscillation), its dynamic parameters should be set in the CCR2+ (integration time and disinfection temperature control gain- PID control) or used factory settings (adapted to thermal actuators type TWA-A).

After the set time has elapsed, the CCR2+ shuts the disinfecting by-pass in the MTCV valve for the given riser by switching the TWA-A actuator off. Water flow in the riser is now controlled solely by the thermostat element in the MTCV valve.

The adopted procedure protects the riser from overheating and reduces the risk of corrosion or accidental burning and reduces the overheating costs. Moreover, after disconnecting the disinfected riser, the water flow rate in the other risers increases, accelerating the disinfection process for the remaining installation.

The disinfection process progress is signalled by outputs contacts O1,...,O4.. This solution is applied where it is necessary to inform the user that the disinfection process is in progress, e.g. in buildings where it is executed automatically (hotels, hospitals etc.).

- **Problems during the disinfection process**

A progress analysis is performed for the entire system and for every single riser during the disinfection process at set intervals (the interval period is among other determined among other by CCR2+ settings).

A list of risers is prepared based on the temperature increase rate measurements for each riser, sorted by the disinfection progress amount. The average disinfection progress in all risers is also calculated at this time. If the average disinfection progress in all risers is positive (better than that defined in the settings), the process continues unchanged. All risers are disinfected, and a subsequent progress analysis is performed after the set period.

If the measured progress of the temperature increase is not positive (slower than defined in the settings), it is highly probable that the disinfection will fail. To ensure realisation, the CCR2+ will (due to special algorithm) divide the installation into smaller parts and perform the process for selected risers. Possible reasons for a non-positive process can include excessive cooling of the branches, an underrated pump and/or scaled pipes.

- **Algorithm**

If progress is insufficient after the interval period, the CCR2+ divides the risers into two groups. The first group includes half of the risers with the best progress. (If there are an

The disinfecting procedure
(continuous)

odd number of risers, the first group numbers half of the risers plus one-half.)

The second group comprises the remaining risers where progress is slow. These risers are excluded from the disinfection process (the riser valves are shut).

As a result of disconnecting the slow progress risers, the pump's delivery is directed to a lower number of better risers, and the possibility of a successful completion of their disinfection becomes higher.

After the next interval period, another analysis of the disinfection progress is performed, and the process is repeated. If the progress in the operating risers is positive, disinfection continues. As each of the operating risers completes the disinfection, its valve is shut, while the valve of the next warmest riser yet to be disinfected is opened. The number of risers disinfected concurrently is constant.

If progress is still insufficient, the risers are again divided into a good half and a bad half, where the latter is disconnected.

In the worst case scenario, following the last split, disinfection will be performed in one riser only and upon its completion the next riser will be served. If even then the progress is not satisfactory, it could mean any of the following. The supply temperature is too low, hydraulic losses are too high, the pump's delivery rate or head is too small.

By applying suitable algorithms, the CCR2+ makes it possible to execute a disinfection process using the existing circulation pump even in the most adverse thermal conditions.

- **End of the thermal disinfection process**
When the disinfection process is finished, the by-pass at the MTCV is closed. The LED status indicator and Reading Menu in App indicates "process successful". It is possible to use outputs (Fig. 4) to indicate any external operation of the disinfection process, e.g.: Disinfection finished.

If the progress of the process is not positive (it is not possible to achieve required disinfection temperature even in a single riser, above-mentioned problems), the CCR2+ will stop the process. When the CCR2+ operates in applications as dependent control – a signal to the weather compensator or another boiler control is sent, and the installation automatically returns to the comfort temperature. When CCR2+ operates as independent control, the maintenance service should reduce the supply temperature after the signal about turn-off the process.

Upon completing disinfection in the last riser, the CCR2+ opens O1 output (Heat Force); and closes O3 output (Disinfection finished), signalling that the process is finished. The main control (in boiler station or sub-station) automatically reduces the supply temperature to return to comfort temperature level.

These signals from the CCR2+ are applied to return to the comfort temperature, when:

- Disinfection process is successful;
- When no progress during the process.

If the supply temperature does not fall (due to some errors), the CCR2+ initially opens the by-pass on the MTCV to achieve a certain flow in the installation (pump protection function).

- **Pump protection against cavitations**
When the disinfection process is finished, the CCR2+ keeps all disinfections, the by-pass is closed. In case of not reduced flow temperature after the disinfection process, the CCR+ runs the pump protection function. The first valve remains open until the temperature on the sensor S0 returns to the normal circulation temperature or ECL (or other electronic control) opens O1 output (Heat Force) and closes O3 output (Disinfection finished).

- **Troubleshooting**
Disinfection will not be completed if:
 - Too low supply temperature in the circulation system;
 - Temperature during the disinfection process was maintained shorter than pre-set (e.g., the electronic control reduced the temperature before the process was finished);
 - The flow in the riser was not sufficient. (e.g. scale in the pipe ...);
 - Any errors in the disinfection process are indicated in the CCR2+ Menu Readings;
 - Analyses of the process have to be made.

- Disinfection will be aborted by the CCR2+ control if:*
 - Disinfecting temperature is not attained in any one of the risers during disinfection, e.g. the hot water temperature is lowered before the process is completed;
 - The hot water supply temperature measured by sensor S0 drops below the disinfecting temperature before disinfection in the risers is completed;
 - Disinfection remains incomplete after 260 minutes;
 - In each case of aborting the disinfection process the control indicates which risers were not disinfected successfully on CCR2+ Menu Readings.
Disinfection may fail for the entire installation or only for selected risers.
Failed disinfection is reported by the CCR2+:
 - On its App (Menu Readings);
 - LED status indicators
 - O4 output closes (Alarm)
 - BMS statuses

The disinfecting procedure
(continuous)

• **Recommendation**

Before starting the thermal disinfection process, please contact your local legislation institution about local regulation and requirements.

Perform water tests for *Legionella pneumophila* bacteria detection to achieve information about bacteria concentration and genus of bacteria as some colonies require higher pasteurisation temperatures.

A successful thermal disinfection process depends on many elements (good pipe insulation, possibility to reach high supply temperature, good pipe condition- no scale inside), it is therefore recommended to:

- Start the process from lower required disinfection temperatures – if the process is successful try to increase the temperature as the pasteurisation process is much faster at higher temperatures;
- Increase the temperature of the process step by step (e.g. every two degrees) remember that a higher demand for thermal disinfection requires a higher supply temperature (what in many cases can be limited due to technical problems with heat sources).

Remember that high temperatures in the system can scald users and increase the risk of precipitation lime deposit.

After two – three processes of thermal disinfections make a water test for bacteria. If correctly performed, the thermal disinfection process results will be visible immediately.

• **Comments**

The Danfoss solution based on electronic controls (MTCV-C + CCR2+ + TVM-W) of the thermal disinfection process allows for maintenance of an appropriate circulation temperature in the systems simultaneously with recognising thermal disinfections in minimum time (for all installations - automatically) and reducing scalding (TVM-W) and precipitation of deposit problems.

The system is designed to provide maximum guarantee of thermal disinfection, while at the same time considering the cost aspect!

CCR2+ settings

Temperature set in the circulation risers and disinfection time:

Temperature of disinfection (°C)	Time setting for thermal disinfection in: hour ... Minute ...	
	Minimum required	Maximum recommended
50	6 h 20 minute	7 h 30minute
51	6 h 10 minute	7 h 20 minute
52	4 h 00 minute	5 h 50 minute
53	2 h 00 minute	4 h 00 minute
54	1 h 00 minute	2 h 00 minute
55	0 h 50 minute	2 h 00 minute
56	0 h 40 minute	1 h 20 minute
57	0 h 20 minute	1 h 00 minute
58	0 h 15 minute	0 h 50 minute
59	0 h 15 minute	0 h 45 minute
60	0 h 14 minute	0 h 40 minute
61	0 h 13 minute	0 h 35 minute
62	0 h 12 minute	0 h 30 minute
63	0 h 12 minute	0 h 28 minute
64	0 h 11 minute	0 h 27 minute
65	0 h 11 minute	0 h 26 minute

Temperature of disinfection (°C)	Time setting for thermal disinfection in: hour ... Minute ...	
	Minimum required	Maximum recommended
66	0 h 10 minute	0 h 25 minute
67	0 h 9 minute	0 h 25 minute
68	0 h 8 minute	0 h 22 minute
69	0 h 7 minute	0 h 21 minute
70	0 h 6 minute	0 h 20 minute
71	0 h 6 minute	0 h 18 minute
72	0 h 6 minute	0 h 14 minute
73	0 h 5 minute	0 h 12 minute
74	0 h 4 minute	0 h 10 minute
75	0 h 3 minute	0 h 10 minute
76	0 h 3 minute	0 h 10 minute
77	0 h 2 minute	0 h 9 minute
78	0 h 2 minute	0 h 8 minute
79	0 h 2 minute	0 h 6 minute
80	0 h 2 minute	0 h 6 minute

Wiring, Dimensions and Installation

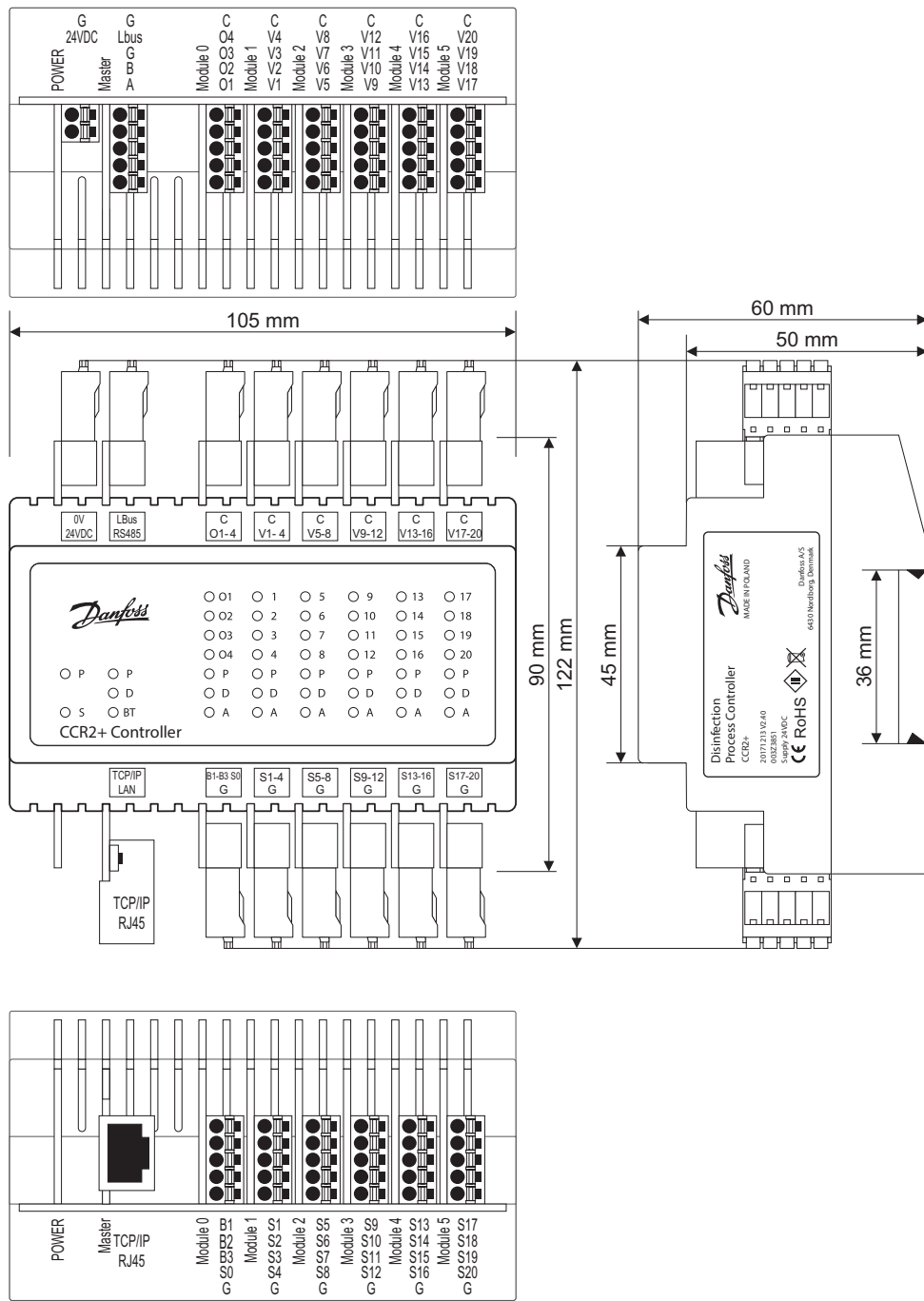

Fig. 4 Wiring scheme - CCR+ Master Controller

Connector/port	Description
0V 24VDC	0V – ground (-) power supply 24 VDC(+) power supply
Lbus RS485	G – ground Lbus port (for system expansion) Lbus – Lbus port (for system expansion) G – ground (Modbus RS 485) B – port B (Modbus RS 485) A – port A (Modbus RS 485)
C O1,..,O4	C – common port dedicated to outputs O1-O4 O1,..O4 – defined outputs
C V1-4	C – common port dedicated to actuators V1-4 O1 - output: Heat Force O2 - output: Start next CCR/Slave Unit O3 - output: Disinfection finished O4 - output: Alarm
C V5-8	C – common port dedicated to actuators V5-8 V5..V8 – outputs to actuators
C V9-12	C – common port dedicated to actuators V9-12 V9..V12 – outputs to actuators

Connector/port	Description
C V13-16	C – common port dedicated to actuators V13-16 V13..V16 – outputs to actuators
C V17-20	C – common port dedicated to actuators V17-20 V17..V20 – outputs to actuators
TCP/IP, LAN	TCP/IP port or IP Modbus port
B1-3, S0 G	B1, B2, B3 defined inputs S0 – temp. sensor G – common ground dedicated to inputs/sensor
S1-4 G	S1..S4 – inputs from sensors G – common ground dedicated to sensor S1-4
S5-8 G	S5..S8 – inputs from sensors G – common ground dedicated to sensors S5-8
S9-12 G	S9..S12 – inputs from sensors G – common ground dedicated to sensors S9-12
S13-16 G	S13..S16 – inputs from sensors G – common ground dedicated to sensors S13-16
S17-20 G	S17..S20 – inputs from sensors G – common ground dedicated to sensors S17-20

Thermal actuator TWA-A

Descriptions



The thermal actuator TWA-A is for use with the MTCV and small Danfoss seated valves.
The actuator starts to move:
- when the signal is applied.

Ordering

Type	Voltage (currentless)	Valve function	Code No.
TWA-A	230 V~	NC	088H3112
TWA-A	24 V	NC	088H3110

Technical data

Supply voltage	24 V AC/DC +30% to -15% 230 V AC. +10% to -15%
Frequency	50 - 60 Hz
Average power consumption	2 W
Spindle travel time (Danfoss valves)	3 minutes
Ambient temperature	0 - 60 °C
Enclosure	IP 41
Cable length	1200 mm
Max. spindle travel	3 mm

Electrical connection and mounting

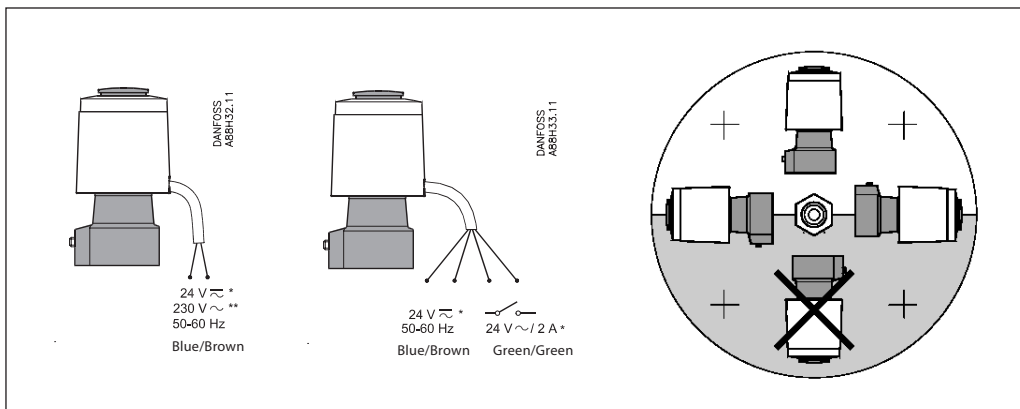

Dimensions

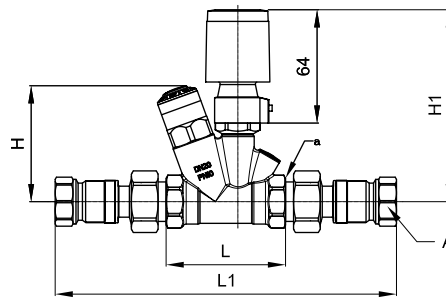

Internal thread	A ISO 7/1	a ISO 7/1	H (mm)	H1 (mm)	L (mm)	L1 (mm)	Weight (kg)	Code No.
DN 15	R _p ¾	R _p ½	79	129	75	220	0,55	003Z4515
DN 20	R _p 1	R _p ¾	92	129	80	240	0,60	003Z4520

Temperature sensors (Pt 1000)

ESM-11, ESMB, ESMC

Application

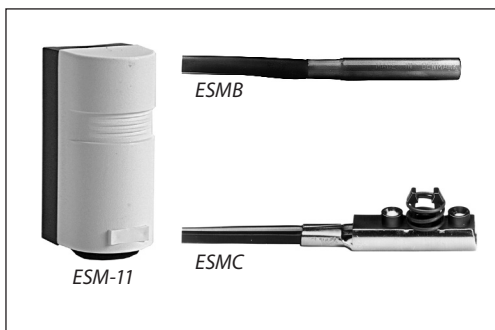

- Platinum-based sensors, 1000 W at 0 °C

All the temperature sensors are two-wire devices, and all connections are inter-changeable.

The surface sensor type ESM-11 has a spring contact surface to ensure a good heat transfer in pipes of all sizes.

The basic sensor contains a platinum element with a characteristic that complies with EN 60751.

Ordering

Temperature sensors

Type	Designation	Code No.
ESM-11	Surface sensor	087B1165
ESMB	Universal sensor	087B1184
ESMC	Surface sensor	087N0011

Accessories and spare parts

Type	Designation	Code No.
Pocket	Immersion, stainless steel 100 mm, for ESMB (087B1184)	084N1082
Pocket	Immersion, stainless steel 250 mm, for ESMB (087B1184)	084N1083
	Heat conducting paste, 3.5 cm ³	041E0110

Wiring

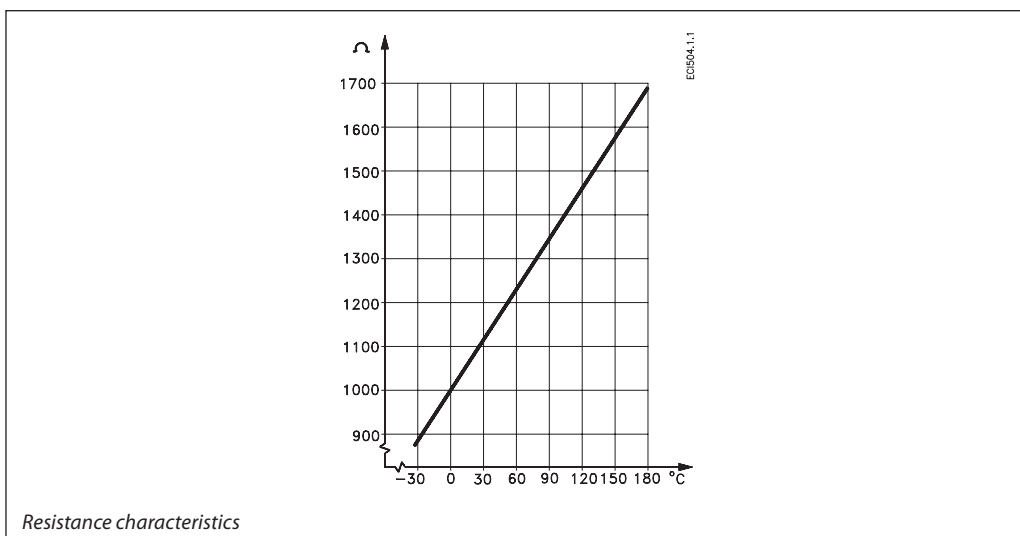
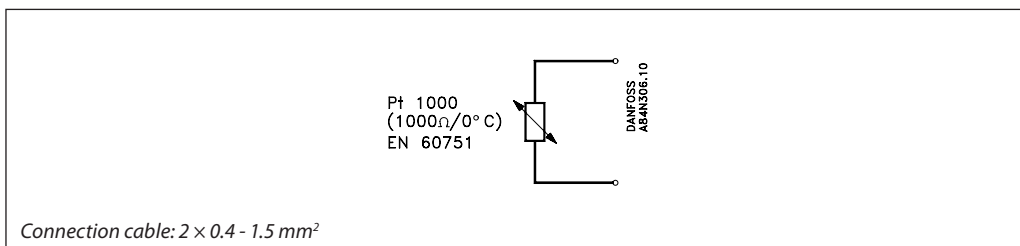

Data sheet

Disinfection Process Control & Temperature Registration

Technical data

All temperature sensors contain a Pt 1000 element. Instructions are supplied with the products.

Type	Temperature range	Enclosure	Time constant	PN
ESM-11	0 ... 100 °C	IP 32	3 s	-
ESMB	0 ... 100 °C	IP 54	20 s	-
ESMC	0 ... 100 °C	IP 54	10 s	-
Pocket	0 ... 200 °C	-	See "Data specific"	25

			Packing
Materials	ESM-11	Cover: ABS	××
		Base: PC (polycarbonate)	
	ESMB	Encapsulation: 18/8 stainless steel	×
		Cable: 2.5 m, PVC, 2 × 0.2 mm ²	
	ESMC	Encapsulation: Top part: nyrol, bottom part: nickel coated Cu	×
Cable: 2 m, PVC, 2 × 0.2 mm ²			
Pocket	Tube and body: AISI 316		
Electrical connection	ESM-11	Terminal block for 2 wires in base part	
	ESMB	2-wire cable (2 × 0.2 mm ²)	
	ESMC	2-wire cable (2 × 0.2 mm ²)	
Mounting	ESM-11/ESMC	Clamp for tube DN 15-65 supplied	
	ESMB	For pipe or flat surface or in pocket	
	Pocket	G 1/2 A	

× = PE (polyethylene) bag
×× = Cardboard

Sensor characteristics	Referring to EN 60751, Class 2 B	Max. deviation 2 K
Time constants	ESMU (Cu) in pocket	32 s (in water) 160 s (in air)
	ESMB in pocket	20 s (in water) 140 s (in air)

Dimensions

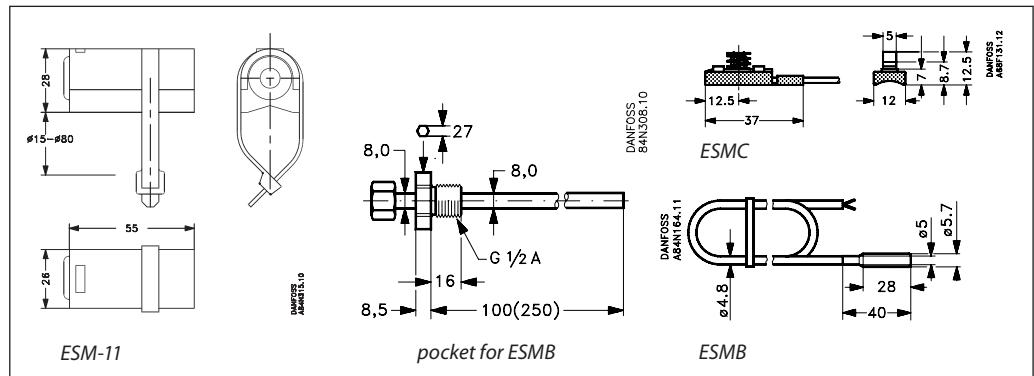

Danfoss A/S

Heating Segment • heating.danfoss.com • +45 7488 2222 • E-Mail: heating@danfoss.com

Danfoss can accept no responsibility for possible errors in catalogues, brochures and other printed material. Danfoss reserves the right to alter its products without notice. This also applies to products already on order provided that such alterations can be made without consequential changes being necessary in specifications already agreed. All trademarks in this material are property of the respective companies. Danfoss and all Danfoss logotypes are trademarks of Danfoss A/S. All rights reserved.