

Data sheet

APP W HC Pumps

APP W HC 15 - 30



Table of Contents	1.	Introduction	3
	2.	Benefits.....	3
	3.	Application examples	3
	4	Technical data	4
	4.1	APP W HC 15 - 30.....	4
	5.	Flow at different rpm.....	5
	5.1	APP W HC 15 - 24 flow curves measured at 120 barg (1740 psig)	5
	5.2	APP W HC 30 flow curves measured at 120 barg (1740 psig)	6
	6	Flushing valve curves	7
	6.1	APP W HC 15 - 30 integrated flushing valve	7
	7.	Motor requirements.....	7
	7.1	Calculation factor for APP W HC 15 - 30 @ 110 barg	7
	8.	Temperature and corrosion.....	8
8.1	Temperature.....	8	
9.	Installation.....	8	
9.1	Filtration.....	9	
9.2	System with direct supply:	9	
10.	Dimensions and connections.....	11	
10.1	APP W HC 15 - 30.....	11	
11.	Dimensions with motor unit.....	12	
11.1	APP W HC 15-30	12	
12.	Accessories	13	
12.1	Accessories for APP W HC 15 - 30	13	
13.	Service.....	13	

1. Introduction

This data sheet is valid for APP W HC pumps. The Danfoss range of APP W HC high-pressure pumps is designed according to EN 809 for use in water applications like:

- High pressure RO
- Zero liquid discharge (ZLD)
- Minimal liquid discharge (MLD)
-

Danfoss APP pumps are positive displacement pumps with axial pistons that move a fixed amount of water in each cycle.

Flow is proportional to the number of input shaft revolutions (rpm). Unlike centrifugal pumps, they produce the same flow at a given speed no matter what the discharge pressure.

Below sectional drawing is an example of an APP pump. The sectional drawing for the specific pump sizes are to be found in the pump instruction.

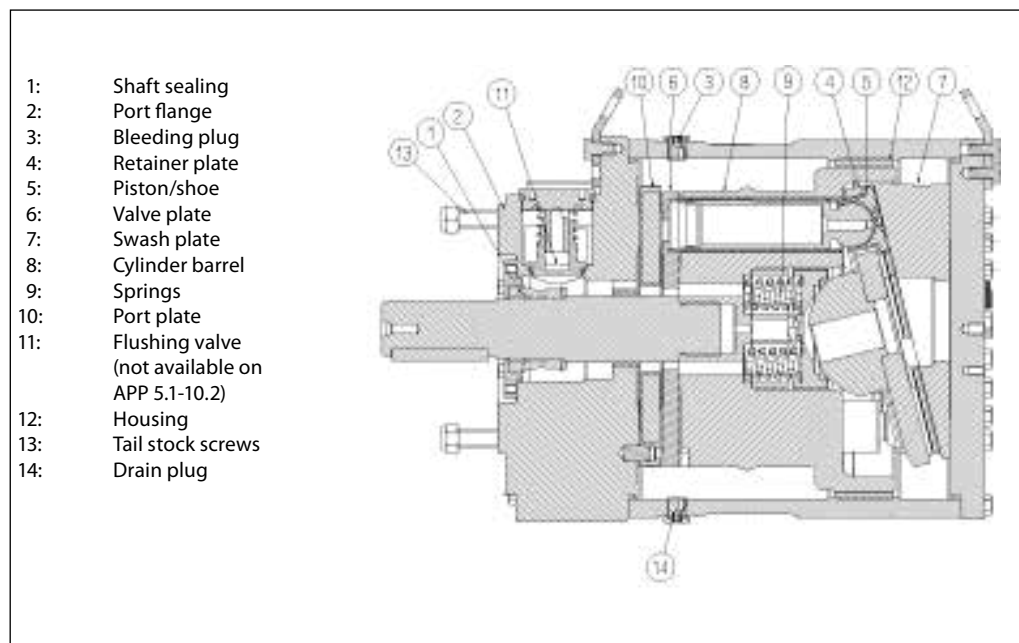

2. Benefits

- **Zero risk of lubricant contamination:**
 - Oil lubricants are replaced with the pumped medium, water, so there is no contamination risk from the pump.
- **Low maintenance costs:**
 - Efficient design and all-stainless steel construction ensure exceptionally long life. When Danfoss specifications are met, service inspections of 8,000 hours can be expected. Service is easy, and can be carried out on-site due to the simple design and few parts.
- **Low energy costs:**
 - The highly efficient axial piston design provides the lowest energy consumption of any comparable pump on the market.
- **Easy installation:**
 - The most compact and lightest design available.
 - The pump can be installed vertically and horizontally.
 - No pulsation dampeners necessary due to extremely low pressure pulsation.
- **Powered directly by electric motors or combustion engines (with special coupling).**
- **All pumps are supplied with an integrated flushing valve that allows the fluid to flow from inlet to the outlet, when the pump is not running.**
- **High reliability:**
 - All parts are made of high corrosion resistant materials e.g. Duplex (EN1.4462/ UNS S31803) and Super Duplex (EN1.4410/UNS S32750) stainless steel and carbon reinforced PEEK.
- **Certified quality:**
 - Positive Material Identification (PMI) report available on request.
 - IATF 16949, ISO 9001, ISO 14001.

3. Application examples

Danfoss APP pumps are designed or use in a broad range of plants around the world for:

- High pressure reverse osmosis
- Zero liquid discharge (ZLD)
- Minimal liquid discharge (MLD)

4 Technical data
4.1 APP W HC 15 - 30

Pump size		APP W HC 15/750	APP W HC 21/1000	APP W HC 24/1200	APP W HC 30/1200
Code number APP		180B5000	180B5001	180B5002	180B5003
Geometric displacement	cm ³ /rev.	362	362	362	444
	in ³ /rev.	22.09	22.09	22.09	27.09
Pressure					
Max. outlet ¹⁾ pressure continuous	barg	120	120	120	120
	psig	1740	1740	1740	1740
Min. outlet ¹⁾ pressure	barg	30	30	30	30
	psig	435	435	435	435
Inlet pressure continuous	barg	2 - 5	2 - 5	2 - 5	2.5-5
	psig	29 - 72.5	29 - 72.5	29 - 72.5	36 - 72.5
Max. inlet pressure peak	barg	10	10	10	10
	psig	145	145	145	145
Speed					
Min. speed continuous	rpm	500	500	500	500
Max. speed continuous	rpm	750	1000	1200	1200
Typical flow - Flow curves available in item 5					
500 rpm at max. pressure	m ³ /h	11	11	11	13
750 rpm at max. pressure	m ³ /h	15	15	15	20
1000 rpm at max. pressure	m ³ /h		21	21	27
1200 rpm at max. pressure	m ³ /h			25	31
Technical specifications					
Media ²⁾ temperature	°C	2 - 50	2 - 50	2 - 50	2 - 50
	°F	36 - 122	36 - 122	36 - 122	36 - 122
Ambient temperature	°C	0-50	0-50	0-50	0 - 50
	°F	32 - 122	32 - 122	32 - 122	32 - 122
Weight (dry)	kg	105	105	105	105
	lb	231	231	231	231
Max. sound pressure level ³⁾	dB(A)	85	85	85	85
Footprint with IEC motor ⁴⁾	m ²	0.76	0.83	1.10	1.10
	foot ²	8.18	8.93	11.84	11.84
Typical motor size					
Max. speed at max. pressure	kW	75	90	110	110
Max. speed at max. pressure	HP	100	125	150	150
Torque at max. outlet pressure	Nm	740	740	740	761
	lbf-ft	546	546	546	561

¹⁾ For lower and higher pressure, please contact Danfoss.

²⁾ Dependent on the NaCl concentration - see chapter 8.

³⁾ A-weighted sound pressure level at 1 m from the pump unit surfaces (reference box) acc. to EN ISO 20361 section 6.2. The noise measurements are performed acc. to EN ISO 3744:2010 on a motor-pump unit at max. pressure and speed.

⁴⁾ Max. area covered with recommended motor configuration (excl. of space to service pump)

5. Flow at different rpm

If the flow required and the rotation speed (rpm) of the pump is known, it is easy to select the pump fitting the application best by using the diagrams below.

Furthermore, these diagrams shows that the flow can be changed by changing the rotation speed of the pump. The flow/rpm ratio is constant, and the "required" flow can be obtained by changing the rotation speed to a corresponding value. Thus, the required rpm can be determined as:

$$\text{Required rpm} = \frac{\text{Required flow} \times \text{Rated rpm}}{\text{Rated flow}}$$

5.1 APP W HC 15 - 24 flow curves measured at 120 barg (1740 psig)

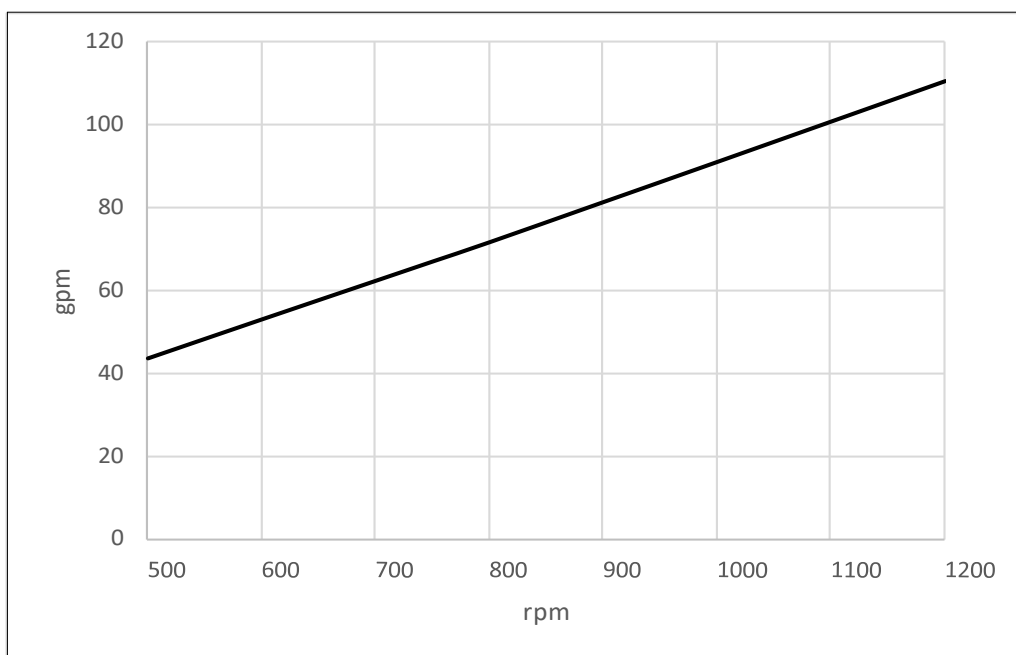
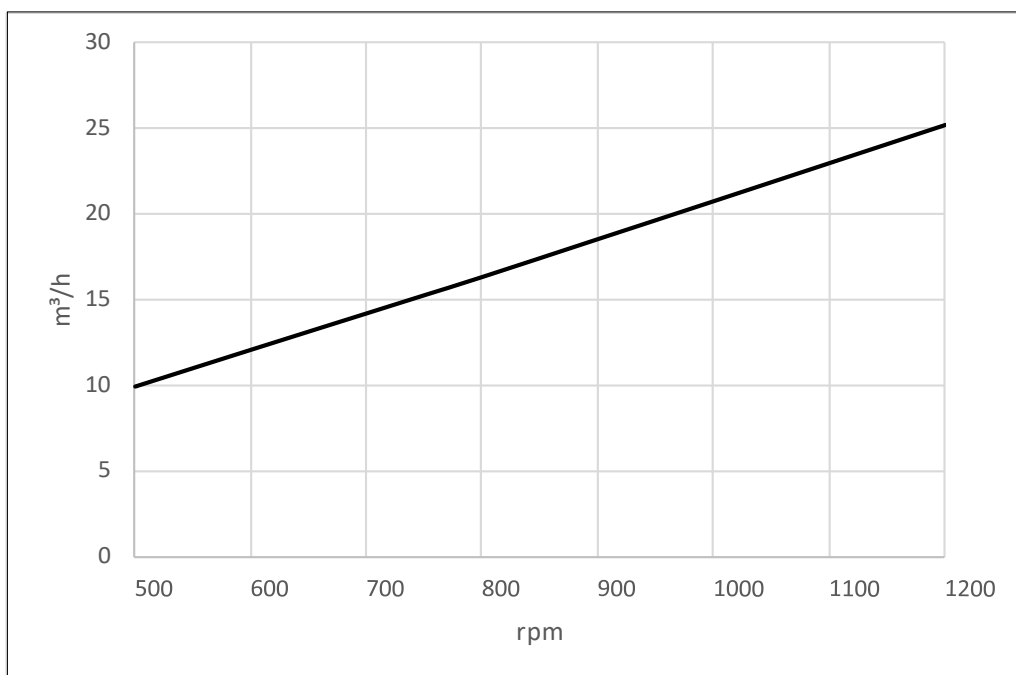

5.2 APP W HC 30 flow curves measured at 110 barg (1595 psig)

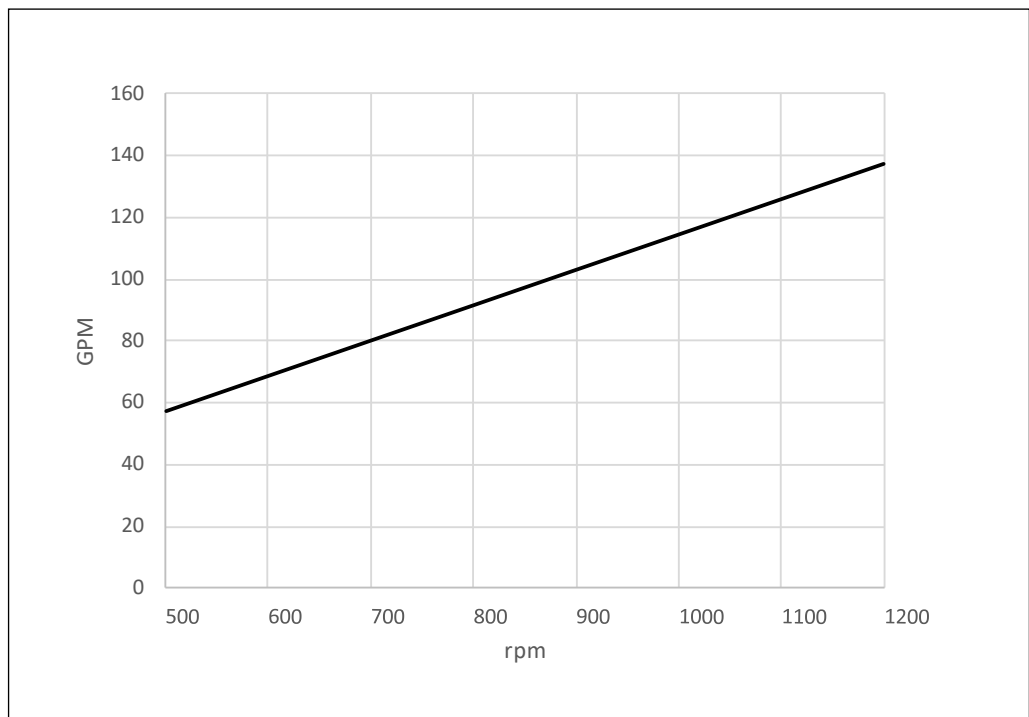
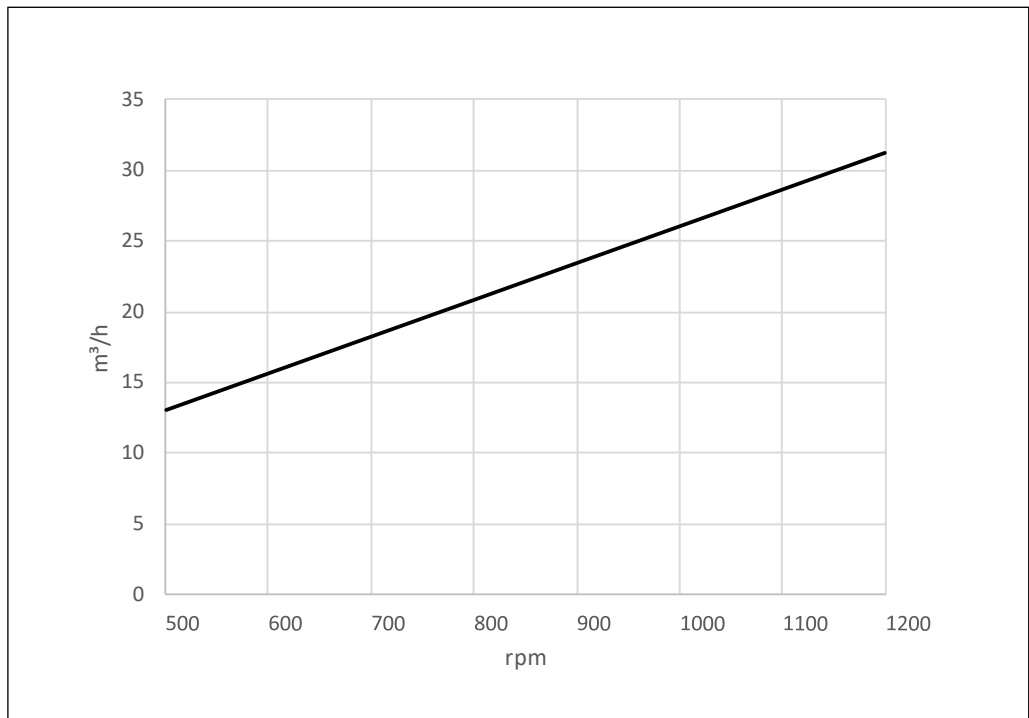

6 Flushing valve curves All pumps are supplied with an integrated flushing valve that allows the fluid to flow from inlet to the outlet, when the pump is not running.

6.1 APP W HC 15 - 30 integrated flushing valve

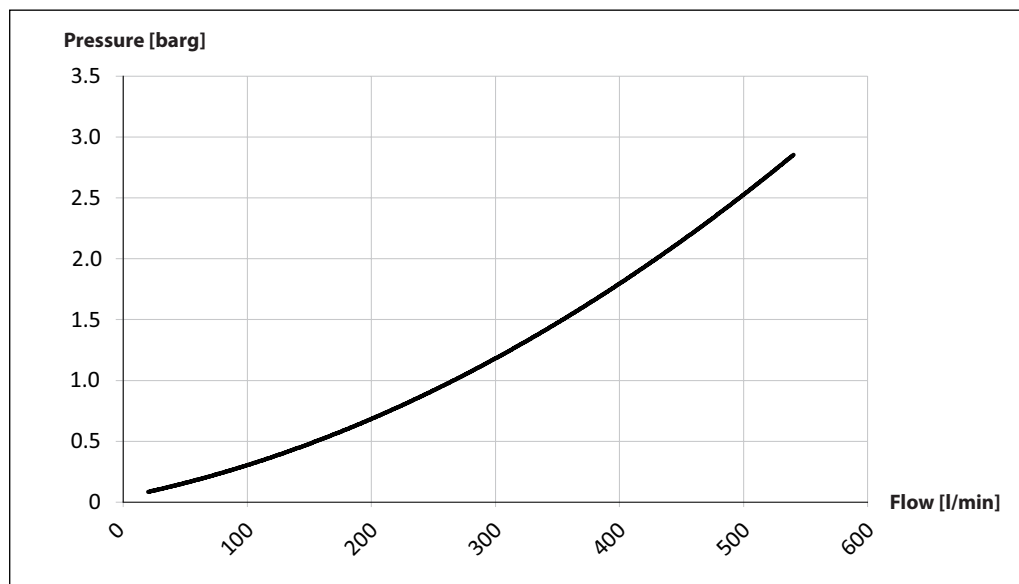

7. Motor requirements The power requirements can be determined using one of the following guiding equations:

$$\text{Required power} = \frac{\text{l/min} \times \text{barg}}{\text{Calc. factor}} \text{ [kW]} \text{ or } \frac{16.7 \times \text{m}^3/\text{h} \times \text{barg}}{\text{Calc. factor}} \text{ [kW]} \text{ or } \frac{0.26 \times \text{gpm} \times \text{psig}}{\text{Calc. factor}} \text{ [hp]}$$

1 hp	=	0.75 kW
1 gpm	=	3.79 l/min
1 m ³ /h	=	4.40 gpm
1 kW	=	1.34 hp
1 l/min	=	0.26 gpm
1 gpm	=	0.23 m ³ /h

7.1 Calculation factor for APP W HC 15 - 30 @ 110 barg

Name	rpm	Calculation factor
APP W HC 15	750	545
APP W HC 21	1000	558
APP W HC 24	1200	562
APP W HC 30	1200	545

8. Temperature and corrosion

8.1 Temperature

Fluid temperature: Min. +2°C to max. +50°C (Min. +35.6°F to max. +122°F)
Ambient temperature: Min. +2°C to max. +50°C (Min. +35.6°F to max. +122°F)

In case of lower operating temperatures, please contact Danfoss High Pressure Pumps.

in order to minimize the risk of crevice corrosion. The chart below illustrates the corrosive resistance of different types of stainless steel related to NaCl concentration and temperature. The APP water pump is made of Duplex and Super Duplex. If the water pump is operated above the Duplex line, always flush water pump with fresh water at operation stop in order to minimize the risk of crevice corrosion.

8.2 Corrosion

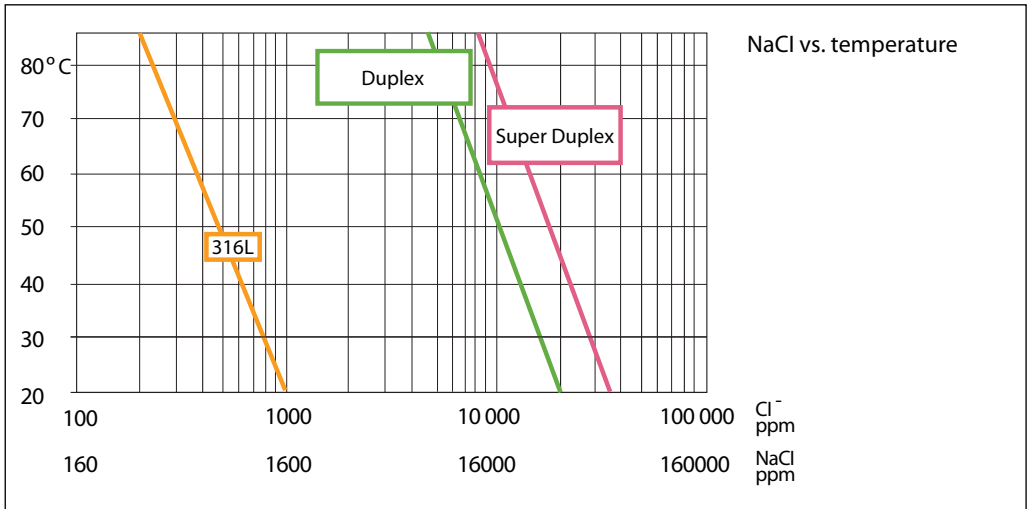

9. Installation

See example below on how to mount the pump and connect it to an electric motor or combustion engine (special coupling).

If alternative mounting is required, please contact your Danfoss sales representative for further information.

Note: Do not add any axial or radial loads to the pump shaft.

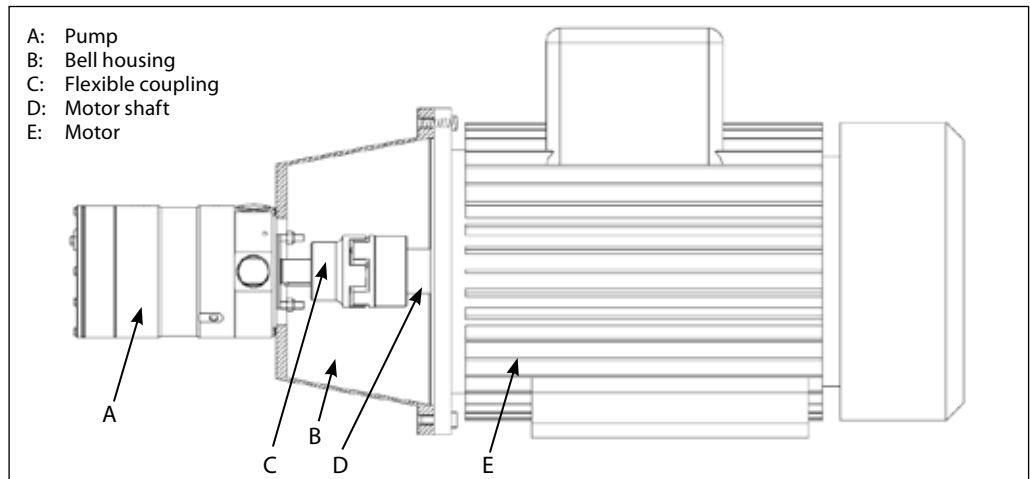

9.1 Filtration

Proper filtration is crucial for the performance, maintenance and warranty of your pump.

Protect your pump, and the application in which it is installed, and by always ensuring that all filtration specifications are met, and by always changing filter cartridges according to schedule.

Since water has very low viscosity, Danfoss APP pumps have been designed with very narrow clearances in order to control internal leakage rates and improve component performance.

To minimize wear on the pump, it is therefore essential to filter inlet water properly.

The main filter must have a filtration efficiency of 99.98% at 10 µm. We strongly recommend that you always use precision depth filter cartridges rated 10µm abs. $\beta_{10} \geq 5000$.

Please note that we do not recommend bag filters or string-wound filter cartridges, which typically have only 50% filtration efficiency. This means that out of the 100,000 particles that enter such filters, 50,000 particles pass right through; compare this to precision depth filters that are 99.98% efficient, and only allow 20 of the same 100,000 particles to pass through.

For more information on the importance of proper filtration, including explanation of filtration principles, definitions and guidance on how to select the right filter for your pump, please consult our Filtration information and specifications (Danfoss document number 521B1009).

Noise

Since the pump unit is typically mounted on a frame or bell housing the overall noise level can only be determined for a complete system. To minimize vibrations and noise throughout the system, it is therefore very important to mount the pump unit correctly on a frame with anti-vibration-dampeners, and to use flexible hoses rather than metal pipes where possible.

The noise level is influenced by:

- **Pump speed:**
High rpm generates more fluid/structure borne pulsations/vibrations than low rpm, because of higher frequency.
- **Discharge pressure:**
High pressure generates more noise than low pressure.
- **Pump mounting:**
Rigid mounting generates more noise than flexible mounting, because of structure-borne vibrations. Be sure to use dampers when mounting.
- **Connections to pump:**
Pipes connected directly to the pump make more noise than flexible hoses, because of structure-borne vibrations.

- **Variable frequency drives (VFD):**
Motors regulated by VFDs can produce more noise if the VFD does not have the right settings.

9.2 System with direct supply:

Inlet line:

- a) Dimension the inlet line to obtain minimum pressure loss (large flow, minimum pipe length, minimum number of bends/connections, and fittings with low or no pressure losses). If relevant, please consult "Parallel coupled pumps and iSaves" (180R93549)

Inlet filter:

- b) Install an inlet filter (1) in front of the APP pump (2). Please consult section 9.1, "Filtration" for guidance on how to select the right filter. Thoroughly clean pipes and flush system prior to start-up.

Low pressure relief valve:

- c) Install a low pressure relief valve (9) in order to avoid system or pump damage in case the pump stops momentarily or is spinning backwards.

Monitoring pressure switch:

- d) Install a monitoring pressure switch (3) between the filter (1) and the pump inlet. Set the minimum inlet pressure according to specifications described in item 4 about technical data. If the inlet pressure is lower than the minimum pressure set, the monitoring pressure switch must prevent the pump from starting or from running.

Hoses:

- e) Use flexible hoses (4) to minimize vibrations and noise.

Inlet pressure:

- f) In order to eliminate the risk of cavitation and other pump damage, pump inlet pressure must always be maintained according to specifications described in item 4 about technical data.

Flushing valve:

- g) For easy system filling and flushing, an integrated flushing valve (6) is in the APP pump.

Non-return valve:

- h) A non-return valve (7) in outlet can be installed in order to avoid backspin of the pump. The volume of water in the membrane vessel works as an accumulator and will send flow backwards in case of the pump stops momentarily.

- i) **High pressure safety or relief valve:**
 As the Danfoss APP pump begins to create pressure and flow immediately after start-up and regardless of any counter pressure, a safety or pressure relief valve (8) should be installed after the non-return valve to prevent system damage and to avoid high pressure peaks.

Note: If a non-return valve is mounted in the inlet line, a low-pressure relief valve is also required between the non-return valve and pump as protection against high-pressure peaks.

Preferred design - see section 9.2

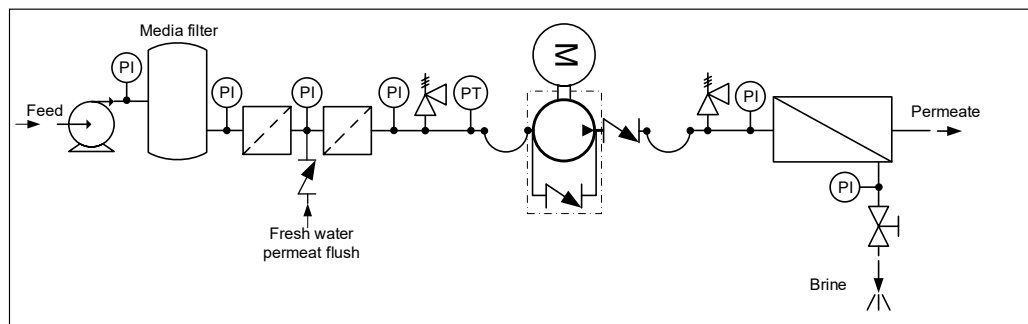

10. Dimensions and connections

10.1 APP W HC 15 - 30

Accessories see section 12. For more details on the accessories, please contact the Danfoss High Pressure Pumps sales organisation.

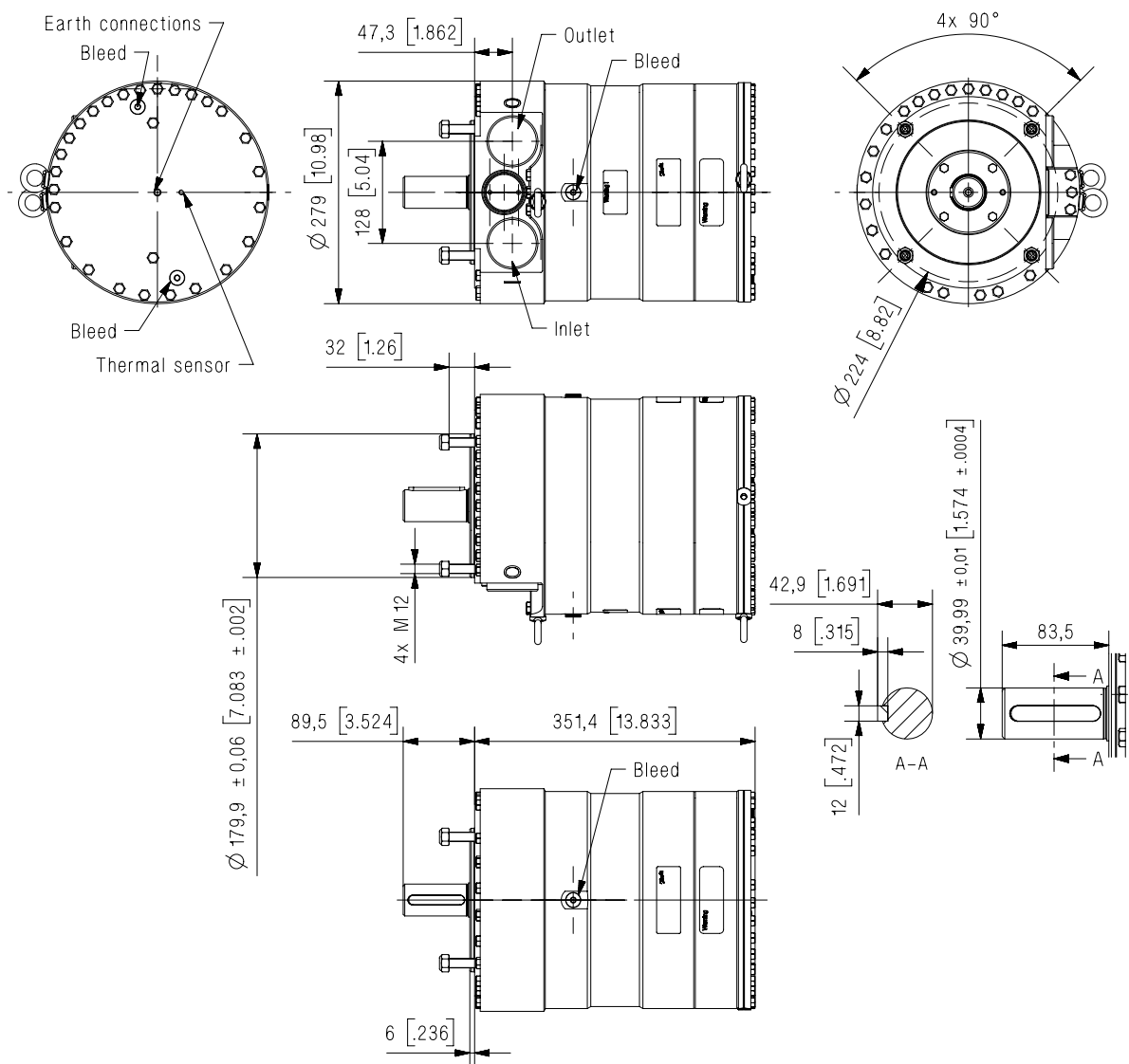

Dimensions without tolerances acc. To ISO 2768-1 designation C.

Description	APP W C 15 - 30
Parallel key, DIN 6885	12 x 8 x 70 mm 0.47 x 0.31 x 2.76 inch
Bleed	G 1/4", hex key 6 mm
Inlet port	M60x1.5; depth 23 mm
Outlet port	M60x1.5; depth 23 mm
Earth connection	M8, depth 11 mm
Thermal sensor	M6, depth 11 mm

11. Dimensions with motor **11.1 APP W HC 15 -30 unit**

The examples of assemblies with motor are only for IEC motors and couplings. Please make sure to check required motor power and dimensions when selecting size of pump and motor. For advice and calculation tool, please contact Danfoss.

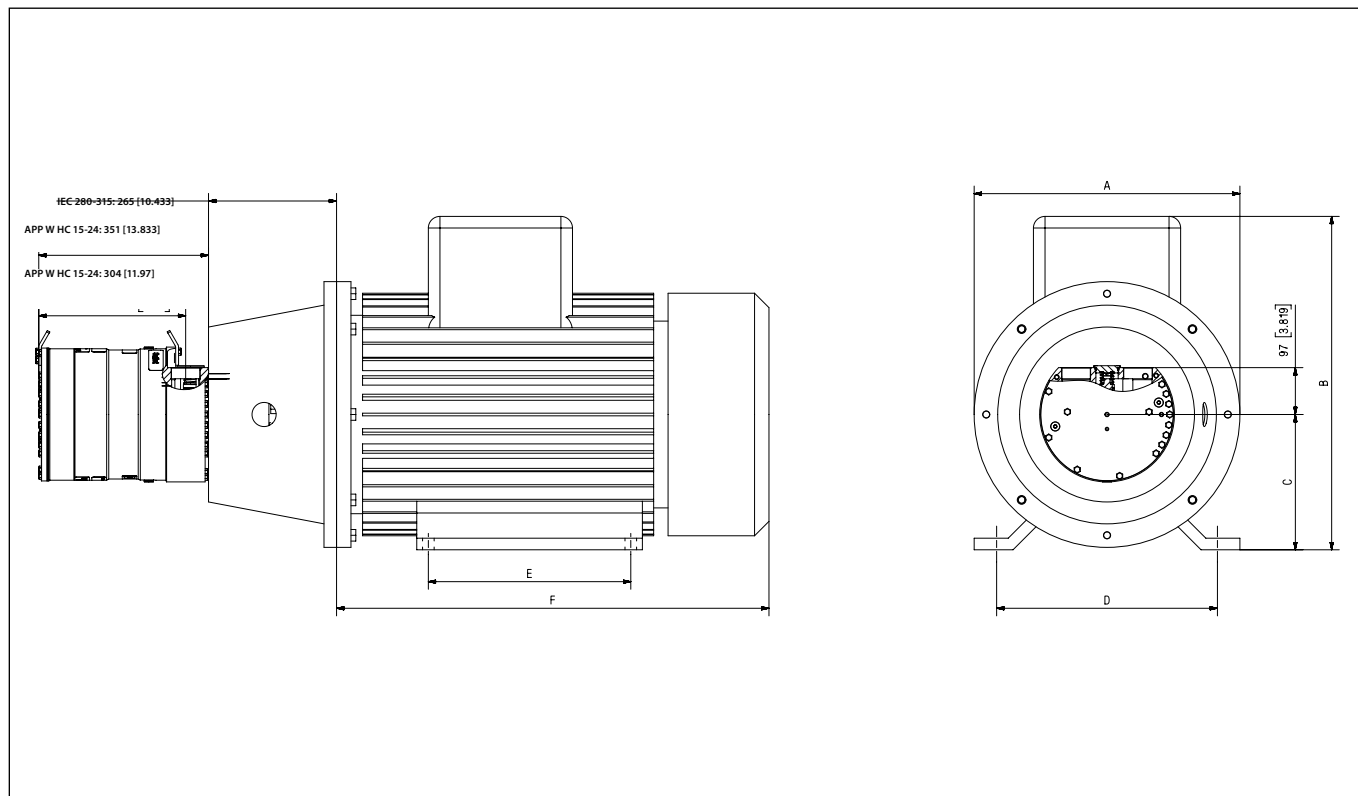

Pump	A mm (inch)	B mm (inch)	C mm (inch)	D mm (inch)	E mm (inch)	F mm (inch)	IEC Electric motor
APP W HC 15	550 (21.65)	693 (27.28)	280 (11.02)	457 (17.99)	368 (14.49)	845 (33.37)	75 kW, IEC 280S-4
APP W HC 21	550 (21.65)	693 (27.28)	280 (11.02)	457 (17.99)	419 (16.50)	895 (35.24)	90 kW, IEC 280M-4
APP W HC 24/30	660 (25.98)	861 (33.90)	315 (12.40)	508 (20.00)	406 (15.98)	1038 (40.87)	110 kW, IEC 315S-4

12. Accessories

12.1 Accessories for APP W HC 15 - 30

Accessories	Type	Code No.
3" inlet hose kit - 2m (79")	3" Victaulic	180Z0144
2½" outlet high pressure hose 120 barg	2 ½" Victaulic 1 m Style 77DX ¹⁾	180Z1009
2½" outlet high pressure hose 120 barg	2 ½" Victaulic 1.78 m Style 77DX ¹⁾	180Z1008
3" inlet connector	M60 - 3" Victaulic	180B3208
Non-return valve (outlet) Super Duplex	M60 - 2 ½" Victaulic Style 77DX ¹⁾	180H0055

¹⁾ The installation instruction for Style 77DX is located in the Victaulic document I-100 Field Installation Handbook (<http://static.victaulic.com>).
When using hoses, please read Design guides: 180R9084 - Right and wrong - Hose assembly routing tips and 180R9367 - Piping connections.

13. Service

Warranty and chemicals disclaimer

Danfoss APP W HC pumps are designed for long operation, low maintenance and reduced lifecycle costs.

Provided that the pump has been running according to the Danfoss specifications, Danfoss guarantees 8.000 hours service-free operation, however, max. 18 months from date of production.

All pumps comes with NBR seals and shaft seal, ideal for water. When pumping water mixed with chemicals, we recommend assessing or testing the impact from the chemicals on the pump materials (see Part List for full overview of materials). Danfoss product warranty doesn't cover cases where chemicals are the root cause of the failure or claim. Additionally, use of certain chemicals may lead to increase wear and require part replacement more often than the Recommended Service Intervals, which are based on water.

If Danfoss recommendations concerning system-design are not followed, it will strongly influence the life of the APP pumps. Other factors that affect pump performance and lifetime include:

- Running the pump at speed outside specifications.
- Supplying the pump with water at temperature higher than recommended.
- Running the pump at inlet pressure outside specifications.
- Running the pump at outlet pressure outside the specifications.

Maintenance

Periodic inspections are required to ensure worn parts (if any), are replaced in due time. Operational conditions such as water quality should be taken into consideration when determining the frequency of the inspections. Danfoss recommends yearly inspections. It is recommended to order the purpose-designed tool kit.

Pump shutdown:

The APP W HC pumps are made of Duplex/Super Duplex materials with excellent corrosion properties. It is, however, always recommended to flush the pump with freshwater when the system is shut down.

Repair assistance

In case of irregular function of the APP W HC pump, please contact Danfoss High Pressure Pumps.

ENGINEERING
TOMORROW

Danfoss

Danfoss A/S
High Pressure Pumps
DK-6430 Nordborg
Denmark

Danfoss can accept no responsibility for possible errors in catalogues, brochures and other printed material. Danfoss reserves the right to alter its products without notice.
This also applies to products already on order provided that such alterations can be made without subsequential changes being necessary in specifications already agreed.
All trademarks in this material are property of the respective companies. Danfoss and the Danfoss logotype are trademarks of Danfoss A/S. All rights reserved.
