

Data Sheet

EC-LCL1200B-350

Liquid cooled heavy duty LCL-filter

FEATURES

- Compact design including all filter components rated for 300 A_{RMS} and 250 kVA
- Liquid cooled with water-glycol mixture
- High enclosure class IP67, IP6K9K – sealed from moisture and dust
- Ambient temperature up to +85°C and down to -40°C
- Allowed coolant temperature up to +65°C
- Robust design withstanding high levels of mechanical vibrations and shocks
- Integrated contactors and pre-charge circuit

SOFTWARE FEATURES

- Controlled by EC-C1200-450-L
- Automatic pre-charge
- Grid detection
- Phase-loss detection
- Grid voltage dip detection
- Contactor feedback monitoring

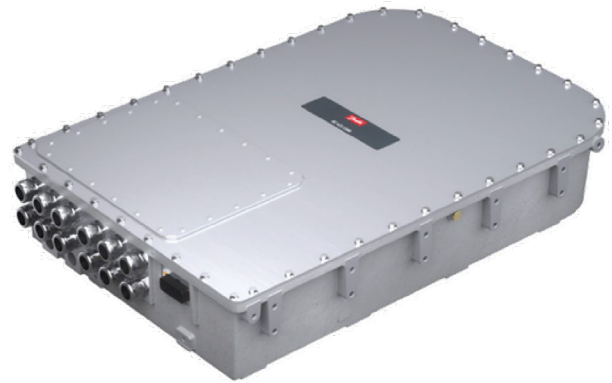

GENERAL

The EC-LCL1200B-350 is a heavy duty LCL-filter designed as an accessory for EC-C1200-450-L inverter.

Combined with EC-C1200-450-L, it can act as Active Front End (AFE) by taking power from grid and feeding power back to grid.

TYPICAL APPLICATIONS

- Grid filter for Active Front End (AFE) used to convert energy from AC grid to DC grid
- Grid filter for frequency converter applications
- Grid filter for grid or generator set powered work machines

SPECIFICATIONS

AC connection	
AC grid voltage range	200-560 V _{AC}
AC grid nominal voltage	500 V _{AC}
AC grid frequency range	Nominal 50-60 Hz Allowed range 45-65 Hz
Max phase current	300 A _{RMS}
Maximum power	250 kVA (500 V _{AC} , 300 A _{RMS})
THD (current)	2.5 % THD (207 kVA, 400 V _{AC} , 50 Hz, 300 A _{RMS})
Efficiency	99 % (400 V, 300 A, 50 Hz)
Nominal switching frequency used	8 kHz
Maximum fuse rating (speed and current)	500 V _{AC} 630 A gG size NH3

Control voltage input	
Voltage range	8-32 V _{DC} (ISO16750-2, 12 V _{DC} class B, 24 V _{DC} class F)
Power	30 W @ 12 V _{DC} , 34 W @ 24 V _{DC}
Current	2.5 A @ 12 V _{DC} , 1.4 A @ 24 V _{DC}

Mechanical	
Dimensions (W x H x L)	590 x 178 x 874 mm (no options)
Weight	126.1 kg +-2 % (no options)

Cooling	
Cooling liquid	Plain water and glycol mixture with appropriate corrosive inhibitor
Cooling liquid mixture	Nominal mixture 50/50 water/glycol (max. 52 % glycol allowed with 1 % current derating per 1 % mixture increase above 50 % glycol content)
Cooling liquid glycol type	Ethylene glycol (Glysantin G48 recommended)
Minimum cooling liquid flow	20 l/min
Maximum operating pressure	2 bar
Pressure loss	220 mbar, 20 l/min, +20°C coolant
Cooling circuit volume	0.57 l
Cooling liquid maximum temperature	+65°C

Ambient Conditions	
Storage temperature	-40°C...+85°C
Operating temperature	-40°C...+85°C (with nominal coolant temp.)
Altitude	max. 4000 m
Relative humidity	98 %
Enclosure class	IP67, IP6K9K
Mechanical vibration	5.9 G _{RMS} ISO 16750-3:2012 Test VII – Commercial vehicle, sprung masses – Table 12 Notes: ambient temperature +20°C, test duration 8h per each axis (x, y and z axes tested), total spectral acceleration 5.9 G _{RMS}

Mechanical shock	<p>20 G ISO 16750-3:2012 4.2.2 Test for devices on rigid points on the body and on the frame Notes: –acceleration: 200 m/s²; –duration: 6 ms; –number of shocks: 10 per test direction</p>
------------------	---

Connections	
Coolant connection	2x G3/4" female threads, coolant connection surface complies with ISO 1179-1 within 40 mm diameter around the coolant port
HV cable recommended type	HUBER+SUHNER Radox Elastomer S screened automotive cable www.hubersuhner.com
Inverter side cable cross section	up to 120 mm ² (Cu)
Inverter side connection	6x M32x1.5 thread
Inverter side cable lug size	35-8, 50-8, 70-8, 95-8, 120-8
Grid side connection	6x M32x1.5 thread
Grid side cable lug size	35-8, 50-8, 70-8, 95-8, 120-8
Recommended cable lug	<p>35 mm²: Druseidt with narrow flange 03901 50 mm²: Druseidt with narrow flange 03903 70 mm²: Druseidt with narrow flange 03906 95 mm²: Druseidt with narrow flange 03910 120 mm²: Druseidt with narrow flange 03914 www.druseidt.de</p>
LV connector	35-pin Tyco electronics AMPSEAL connector www.te.com
LV connector type	part no. 776163-1
LV connector pin configuration	See section SIGNAL CONNECTOR PINOUT
LV mating connector type	TE 776164-1
LV mating connector pin type	0.5-1.25 mm ² : TE 770854-3 (gold plated)

Standards and classifications	
Low Voltage Directive 2014/35/EU	
EN 62477-1:2012 (see user guide for details)	
EN IEC 61800-3:2018 Applicable part: Category C3 conductive EMC limits (DUT I > 100 A)	
EN 62477-1:2012 Protective class I	

PRESSURE LOSS VS COOLANT FLOW

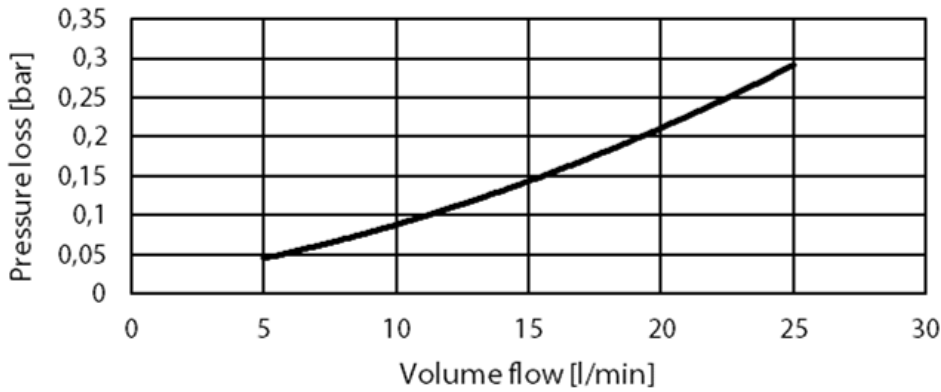

Picture 1 Device pressure loss vs coolant flow (+20°C coolant)

DIMENSIONS

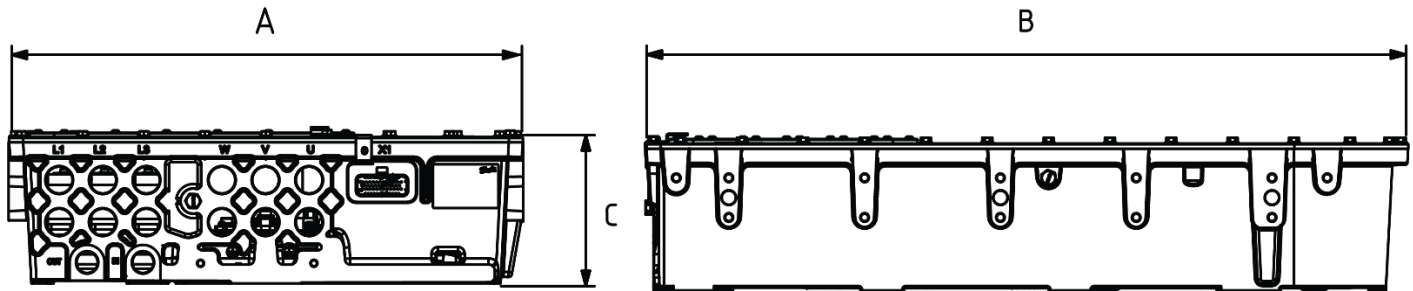

Picture 2 Device dimensions (no options)

Dimension	Length
A	590 mm
B	874 mm
C	178 mm

INTERNAL SCHEMATIC AND COMPONENTS

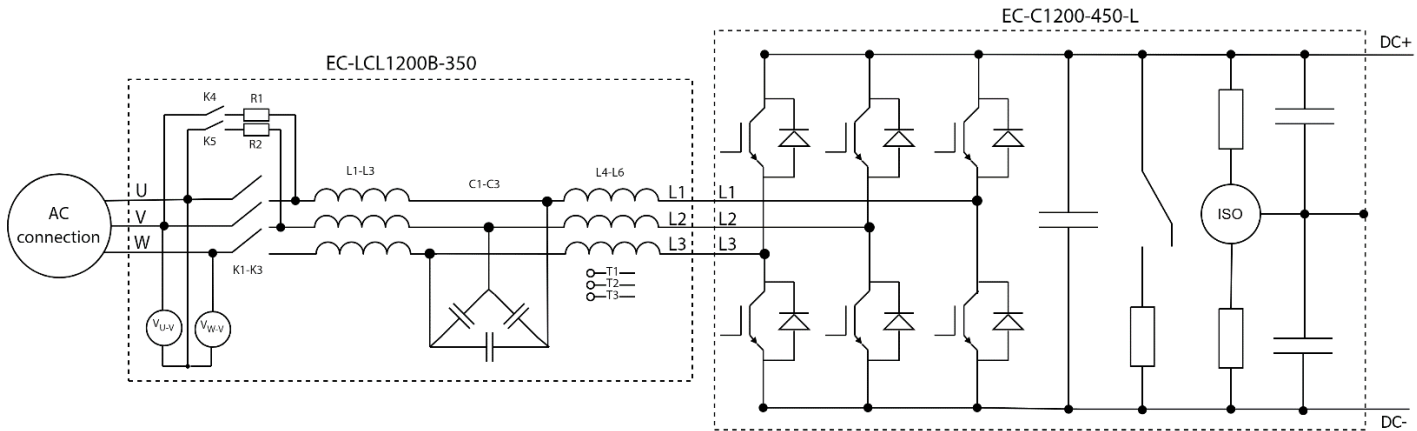

Picture 3 Internal schematic

Component	Description
L1-L3	0.04 mH (used as grid-side inductance parameter for C1200-450)
L4-L6	0.115 mH (used as converter-side inductance parameter for C1200-450)
C1-C3	3x 56 μ F (delta connected, 168 μ F used as capacitance parameter for C1200-450)
K1-K3	Main contactors
K4, K5	Pre-charge contactor
T1, T2, T3	Temperature sensors
R1, R2	20 Ω

Table 1 Components

SIGNAL CONNECTOR PINOUT

Pin number	Signal name	Comments
1	VIN_P	Positive Power Supply (8-33V)
2	POWER_ON	Active High, Turn ON/OFF @ ~2V, 10K Pulldown
3	#STOP 2	Active Low, STOP @ < 1.2V, RUN @ > 4.65V, max. 11mA@24VDC Pulling one #STOP down opens the contactors.
4	GND_IO2	GND for STOP1/2, POWERON, MEAS_A/B
5	Reserved	-
6	PT 2	Signal for internal temperature measurement Signal is routed directly from LCL internal temperature sensor.
7	Reserved	-
8	Reserved	-
9	Reserved	-
10	#CONTACTOR_FB	Feedback signal for contactors. '0' -> OK. Open collector output with 10K pullup to VP5_IO.
11	POWERGOOD	Signal for monitoring LCL controller status, '1' -> OK Monitoring is implemented for power supplies.
12	CONT 1	Contactor control for precharge Active High, Turn ON/OFF @ ~2V, 22K Pulldown
13	VIN_N	Negative Power Supply (0V)
14	GND_IO2	GND for STOP1/2, POWERON, MEAS_A/B
15	GND_IO2	GND for STOP1/2, POWERON, MEAS_A/B
16	MEAS_A_N	High voltage measurement
17	GND_IO2	GND for STOP1/2, POWERON, MEAS_A/B
18	PT 1	Signal for internal temperature measurement Signal is routed directly from LCL internal temperature sensor.
19	HVIL	High Voltage Interlock Loop, internally connected to pin 31
20	Reserved	-
21	Reserved	-
22	GND_IO	GND for POWERGOOD, CONTACTOR_FB, CONT 1/2
23	CONT 2	Contactor control for main contactors Active High, Turn ON/OFF @ ~2V, 22K Pulldown
24	#STOP 1	Active Low, STOP @ < 1.2V, RUN @ > 4.65V, max. 11mA@24VDC Pulling one #STOP down opens the contactors.
25	Reserved	-
26	MEAS_B_N	High voltage measurement
27	MEAS_B_P	High voltage measurement
28	MEAS_A_P	High voltage measurement
29	PT 3	Signal for internal temperature measurement Signal is routed directly from LCL internal temperature sensor.
30	GND_TEMP	GND for temperature measurement
31	HVIL	High Voltage Interlock Loop, internally connected to pin 19
32	Reserved	-
33	Reserved	-
34	Reserved	-
35	GND_ENCLOSURE	Enclosure ground

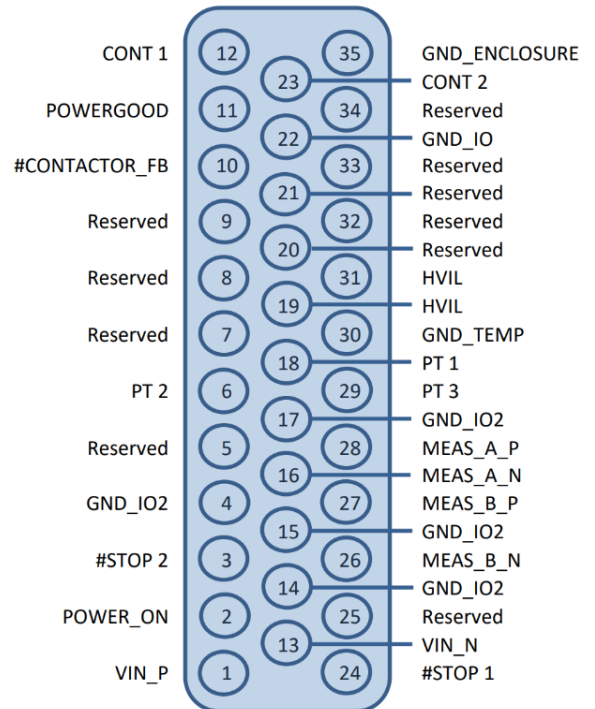

PRODUCT CODE AND OPTIONS

Use product code including all needed options for ordering. Standard options do not need to be listed in the code as they are selected by default if a non-standard option is not selected. Standard options are indicated by a star (*).

EC-LCL1200B-350 is designed to be used in combination with the EC-C1200 converter.

Product code	Description
EC-LCL1200B-350	Standard unit without any options
EC-LCL1200B-350+CG1	LCL-filter with cable glands

Table 2 Product code examples for device

Variant	Code	Description	Additional information
Glands	*	No glands	No cable glands, plugs, screws, springs or washers
	+CG1	Default M25/M32 cable glands	With 3x M32 to M25 adapters and 3x M25 cable glands (3x for phases) on inverter side, 3x M32 cable glands on grid side. Unused threads plugged with 6x M32 plugs. Screws, springs and washers for cable lugs included in the delivery packed in a plastic bag. Screws 6x M8x20, TX, ISO14580 with washers and preapplied thread locker
	+CG2	Default M25/M32 cable glands	With 6x M32 to M25 adapters and 6x M25 cable glands (6x for phases) on inverter side, 6x M32 cable glands on grid side and 6x copper bushings for double connection. Screws, springs and washers for cable lugs included in the delivery packed in a plastic bag. Screws 6x M8x60, TX, ISO14583, spring disc D8, DIN 2093, 8.2x16x0.9, washer D8, DIN 125, zinked

*Standard option

Table 3 Option list

Danfoss can accept no responsibility for possible errors in catalogues, brochures and other printed material. Danfoss reserves the right to alter its products without notice. This also applies to products already on order provided that such alterations can be made without changes being necessary in specifications already agreed. All trademarks in this material are property of the respective companies. Danfoss and the Danfoss logotype are trademarks of Danfoss A/S. All rights reserved.