

Design Guide

iC2-Micro Frequency Converters



Contents

1 Introduction and Safety

1.1 Purpose of this Design Guide	9
1.2 Additional Resources	9
1.3 Planning and Design Support Materials	9
1.4 Version History	9
1.5 Safety Symbols	10
1.6 Medical Devices	10
1.7 General Safety Considerations	10
1.8 Qualified Personnel	12

2 Approvals and Certifications

2.1 Product Approvals and Certifications	13
2.2 Standards	14
2.3 Export Control Regulation	15

3 iC2-Micro Frequency Converters

3.1 Intended Use	16
3.2 Block Diagram	16
3.3 Ecodesign for Power Drive Systems	17
3.3.1 Overview	17
3.3.2 Power Losses and Efficiency	18
3.4 Power Hardware	19
3.5 Control and Interfaces	19
3.5.1 Control Terminals	19
3.5.2 RJ45 Port and RS485 Termination Switch	20
3.5.3 Control Panel and Control Panel 2.0 OP2	21
3.5.4 Control Panel Buttons and Indicators	22
3.5.5 Control Panel 2.0 OP2 Buttons and Indicators	24
3.5.6 Sliding Door on the Terminal Cover	25
3.6 Application Software	26
3.6.1 iC2-Micro Application Software Overview	26
3.6.2 Basic Functions	27
3.6.2.1 Basic Functions Overview	27
3.6.2.2 Reference Handling	27

3.6.2.3	Two Setups	27
3.6.2.4	Ramps	27
3.6.2.5	Quick Stop	27
3.6.2.6	Limit Rotation Direction	27
3.6.2.7	Motor Phase Switch	27
3.6.2.8	Inching with Jogging Modes	27
3.6.2.9	Frequency Bypass	27
3.6.2.10	Automatic Restart	28
3.6.2.11	Flying Start	28
3.6.2.12	Mains Dropout	28
3.6.2.13	Kinetic Backup	28
3.6.2.14	Resonance Damping	28
3.6.2.15	Mechanical Brake Control	28
3.6.2.16	Controllers	28
3.6.3	IO Control and Readouts	29
3.6.4	Motor Control Features	29
3.6.4.1	Motor Control Features Overview	29
3.6.4.2	Motor Types	29
3.6.4.3	Load Characteristics	29
3.6.4.4	Motor Control Principle	29
3.6.4.5	Motor Nameplate and Catalog	29
3.6.4.6	Automatic Motor Adaptation (AMA)	29
3.6.4.7	Automation Energy Optimization (AEO)	29
3.6.5	Braking of Load	29
3.6.5.1	Braking of Load Overview	29
3.6.5.2	Resistor Braking	30
3.6.5.3	Overvoltage Control (OVC)	30
3.6.5.4	DC Brake	30
3.6.5.5	AC Brake	30
3.6.5.6	DC Hold	30
3.6.5.7	Load Sharing	30
3.6.6	Protection Features	30
3.6.6.1	Grid Protections	30
3.6.6.2	Drive Protection Features	30
3.6.6.3	Motor Protection Features	31
3.6.6.4	Protection of Externally Connected Components	31
3.6.6.5	Automatic Derating	31
3.6.7	Monitoring Features	31

3.6.7.1	Monitoring Features Overview	31
3.6.7.2	Speed Monitoring	31
3.6.7.3	Event Log and Operational Counters	31
3.6.8	Software Tools	31
3.6.8.1	Software Tools Overview	31
3.6.8.2	MyDrive® Select	32
3.6.8.3	MyDrive® Harmonics	32
3.6.8.4	MyDrive® ecoSmart™	32
3.6.8.5	MyDrive® Insight	32
3.7	Brake Functions	32
3.7.1	Mechanical Holding Brake	32
3.7.2	Dynamic Braking	32
3.7.3	Brake Resistor Selection	33
3.7.3.1	Introduction	33
3.7.3.2	Brake Resistance Calculation	33
3.7.3.3	Danfoss Recommended Brake Resistance Calculation	34
3.7.3.4	Control with Brake Function	35
4	Specifications	
4.1	Electrical Data	36
4.1.1	Mains Supply 1x100–120 V AC	36
4.1.2	Mains Supply 1x200–240 V AC	36
4.1.3	Mains Supply 3x200–240 V AC	37
4.1.4	Mains Supply 3x380–480 V AC	38
4.2	General Technical Data	39
4.2.1	Protection and Features	39
4.2.2	Grid Side	39
4.2.3	Motor Output and Motor Data	40
4.2.4	Torque Characteristics	40
4.2.5	Control I/O	40
4.2.5.1	Control I/O Overview	40
4.2.5.2	Digital and Pulse Input	41
4.2.5.3	Digital and Pulse Output	41
4.2.5.4	Analog Input	42
4.2.5.5	Analog Output	42
4.2.5.6	Relay Output	43
4.2.5.7	Auxiliary Voltages	43

4.2.6 RS485 Serial Communication	44
4.2.7 Ambient Conditions	44
4.2.7.1 Overview of Ambient Conditions	44
4.2.7.2 Ambient Conditions during Storage	44
4.2.7.3 Ambient Conditions during Transport	45
4.2.7.4 Ambient Conditions during Operation	45
4.3 Fuses and Circuit Breakers	45
4.4 Power Connectors	46
4.5 Acoustic Noise	48
4.6 EMC Compliance Levels	48
4.6.1 Overview of EMC Compliance Levels	48
4.6.2 Emission Requirements	49
4.6.3 EMC Immunity Requirements	49
4.7 EMC Compatibility and Motor Cable Length	51
4.8 dU/dt Conditions	51
4.9 Derating	53
4.9.1 Overview of Derating	53
4.9.2 Manual Derating	53
4.9.3 Automatic Derating	56
5 Exterior Dimensions	
5.1 IP20/Open Type Enclosure Sizes and Dimensions	57
5.2 IP21/UL Type 1 Enclosure Sizes and Dimensions	58
5.3 NEMA 1 Enclosure Sizes and Dimensions	59
6 Mechanical Installation Considerations	
6.1 Contents of the Shipment	60
6.2 Product Labels	60
6.2.1 Product Labels Overview	60
6.2.2 Product Labels on Drives	60
6.2.3 Package Labels	61
6.3 Recommended Disposal	62
6.4 Storage until Installation	62
6.4.1 Reforming the Capacitors	62
6.4.2 Safe Transportation and Storage	63
6.5 Prerequisites for Installation	64

6.5.1 Overview of Prerequisites for Installation	64
6.5.2 Operating Environment	64
6.6 Maintenance Considerations	65
6.6.1 Regular Maintenance	65
6.6.2 Preventive Maintenance Recommendations	65
6.6.3 Service Access	67
6.6.4 Heat Sink and Fan Maintenance and Service	68
6.7 Mechanical Installation	68
6.7.1 Mounting Considerations	68
6.7.2 Mounting Locations	69
6.7.3 Mounting Directions	69
6.7.4 Recommended Screws and Bolts	69
6.7.5 Drilling Patterns	70
6.7.6 Placement of the Drive in the Installation	71
6.7.7 Cooling	71
6.7.8 Recommended Space for Service Access	72

7 Electrical Installation Considerations

7.1 Electrical Installation Precautions	74
7.2 Wiring Diagram	75
7.3 Grid Type and Protection	76
7.3.1 Grid Types	76
7.3.2 Currents on Protective Earth and Potential Equalization/Leakage Currents	76
7.3.3 PE Current Measurement	77
7.3.4 Residual Current Device (RCD) Protection	78
7.3.5 Isolation Monitoring Devices	79
7.4 EMC-compliant Installation	79
7.4.1 EMC-compliant Installation Guidelines	79
7.4.2 Power Cables and Grounding	81
7.4.3 Control Cables	82
7.5 Galvanic Isolation	82
7.6 Ground Leakage Current	83
7.7 Motor Installation	85
7.7.1 Motor Installation Considerations	85
7.7.2 Supported Motor Types	85
7.7.3 Motor Insulation	85

7.7.4 Bearing Currents	85
7.7.5 Motor Thermal Protection	86
7.8 Extreme Running Conditions	87
7.9 Power Cable	88
7.9.1 Power Cable Considerations	88
7.9.2 Torque Requirements	89
7.10 Electrical Installation	89
7.10.1 Mains, Motor, and Grounding Connection	89
7.10.2 Connecting the Motor	91
7.10.3 Connecting AC Mains	91
7.10.4 Control Terminal Types	92
7.10.5 Control Wire Sizes and Stripping Lengths	93
7.10.6 Cable Shield Connection	94
7.10.7 Load Sharing/Brake	96
8 How to Order	
8.1 Model Code	98
8.2 Ordering Accessories and Spare Parts	98
8.3 Ordering Brake Resistors	100
8.3.1 Introduction	100
8.3.2 Ordering Brake Resistors 10%	100
8.3.3 Ordering Brake Resistors 40%	101

1 Introduction and Safety

1.1 Purpose of this Design Guide

This design guide is intended for qualified personnel, such as:

- Project and systems engineers.
- Design consultants.
- Application and product specialists.

The design guide provides technical information to understand the capabilities of the iC2-Micro Frequency Converters for integration into motor control and monitoring systems. Its purpose is to provide design considerations and planning data for integration of the drive into a system. It caters for selection of drives and options for a diversity of applications and installations. Reviewing the detailed product information in the design stage enables developing a well-conceived system with optimal functionality and efficiency.

This guide is targeted at a worldwide audience. Therefore, wherever occurring, both SI and imperial units are shown.

1.2 Additional Resources

Additional resources are available to help understand the features, safely install, and operate the iC2-Micro Frequency Converters:

- The operating guide, which provides information about the installation, commissioning, and maintenance of the drive.
- The application guide, which provides information on how to program and includes complete parameter descriptions.
- Facts Worth Knowing about AC Drives, available for download at <http://www.danfoss.com>.
- Other supplemental publications, drawings, and guides are available at <https://www.danfoss.com/en/service-and-support/documentation/>.

Latest versions of Danfoss product documentation are available for download at <http://drives.danfoss.com/downloads/portal>.

1.3 Planning and Design Support Materials

Danfoss provides access to a consolidated product environment that can support throughout the product lifecycle.

Documents

The operating guide, application guide, and design guide for iC2-Micro Frequency Converters are available for download at www.danfoss.com. It is also possible to order printed guides.

Drawings

For each drive, 2D and 3D drawings, and wiring diagrams are available in standard file formats.

Software

Configuration files for iC2-Micro Frequency Converters are available. MyDrive® Suite provides tools that support the entire lifecycle of the drive, from system design to service. MyDrive® Suite is available at <https://suite.mydrive.danfoss.com/>.

Configurator

The product configurator helps in the product selection. When the process has been completed, the product configurator provides a list of relevant documentation and accessories.

1.4 Version History

This guide is regularly reviewed and updated. All suggestions for improvement are welcome.

The original language of this guide is English.

Table 1: Version History

Version	Remarks
AJ402315027937, version 0401	Update for general release 4.

1.5 Safety Symbols

The following symbols are used in Danfoss documentation.



DANGER

Indicates a hazardous situation which, if not avoided, will result in death or serious injury.



WARNING

Indicates a hazardous situation which, if not avoided, could result in death or serious injury.



CAUTION

Indicates a hazardous situation which, if not avoided, could result in minor or moderate injury.

NOTICE

Indicates information considered important, but not hazard-related (for example, messages relating to property damage).

The guide also includes ISO warning symbols related to hot surfaces and burn hazard, high voltage and electrical shock, and referring to the instructions.

	ISO warning symbol for hot surfaces and burn hazard
	ISO warning symbol for high voltage and electrical shock
	ISO action symbol for referring to the instructions

1.6 Medical Devices



WARNING

ELECTROMAGNETIC INTERFERENCE

AC drives and filters may produce electromagnetic interference up to 300 GHz that may affect the functionality of pacemakers and other implanted medical devices.

1.7 General Safety Considerations

When installing or operating the AC drive, pay attention to the safety information given in the instructions. For more information about safety guidelines for installation and operation, refer to the drive's operating guide.

Safe operation guidelines

- The drive is not suitable as the only safety device in the system. Make sure that additional monitoring and protection devices on drives, motors, and accessories are installed according to the regional safety guidelines and accident prevention regulations.
- Before activating any automatic fault reset functions or change limit values, make sure that no dangerous situations can occur after restart. If the auto reset function is activated, the motor starts automatically after an automatic fault reset.
- Keep all doors and covers closed and terminal boxes screwed on during operation of the drive and when mains is connected.
- Drive components and accessories can still be live and connected to mains, even after the operation indicators are no longer illuminated.

WARNING

LACK OF SAFETY AWARENESS

This guide provides important information on preventing injury and damage to the equipment or the system. Ignoring this information can lead to death, serious injury, or severe damage to the equipment.

- Make sure to fully understand the dangers and safety measures present in the application.
- Before performing any electrical work on the drive, lock out and tag out all power sources to the drive.

WARNING



HAZARDOUS VOLTAGE

AC drives contain hazardous voltage when connected to the AC mains or connected on the DC terminals. Failure to perform installation, start-up, and maintenance by qualified personnel can result in death or serious injury.

- Only qualified personnel must perform installation, start-up, and maintenance.

WARNING



DISCHARGE TIME

The drive contains DC-link capacitors, which can remain charged even when the drive is not powered. High voltage can be present even when the warning indicator lights are off.

- Stop the motor, disconnect AC mains, permanent magnet type motors, and remove DC-link supplies, including battery backups, UPS, and DC-link connections to other drives.
- Wait for the capacitors to discharge fully and measure it before performing any service or repair work.
- The minimum waiting time is specified in the table *Discharge time*.

Table 2: Discharge Time

Enclosure size	Minimum waiting time (minutes)
MA01c–MA02c and MA01a–MA03a	4
MA04a–MA05a	15

CAUTION

INTERNAL FAILURE HAZARD

An internal failure in the drive can result in serious injury when the drive is not properly closed.

- Ensure that all safety covers are in place and securely fastened before applying power.

CAUTION**HOT SURFACES**

The drive contains metal components that are still hot even after the drive has been powered off. Failure to observe the high-temperature symbol (yellow triangle) on the drive can result in serious burns.

- Be aware that internal components, such as busbars, may be extremely hot even after the drive has been powered off.
- Do not touch exterior areas that are marked by the high-temperature symbol (yellow triangle). These areas are hot while the drive is in use and immediately after being powered off.

1.8 Qualified Personnel

To allow trouble-free and safe operation of the unit, only qualified personnel with proven skills are allowed to transport, store, assemble, install, program, commission, maintain, and decommission this equipment.

Persons with proven skills:

- Are qualified electrical engineers or persons who have received training from qualified electrical engineers and are suitably experienced to operate devices, systems, plants, and machinery in accordance with pertinent laws and regulations.
- Are familiar with the basic regulations concerning health and safety/accident prevention.
- Have read and understood the safety guidelines given in all guides provided with the unit, especially the instructions given in the operating guide of the drive.
- Have good knowledge of the generic and specialist standards applicable to the specific application.

2 Approvals and Certifications

2.1 Product Approvals and Certifications

iC2-Micro Frequency Converters comply with the required standards and directives. For detailed information on which approvals and certifications a product has, see the product type label and <http://www.danfoss.com>.

Certificates and Declarations of Conformity are available on request or at <https://www.danfoss.com/en/service-and-support/documentation/>.

Table 3: Approvals and Certifications Applicable to Drives







Approval	Description
	The drive complies with relevant directives and their related standards for the extended Single Market in the European Economic Area. For more information, see Table 4 .
	The Underwriters Laboratory (UL) mark indicates the safety of products and their environmental claims based on standardized testing. The drive complies with UL 61800-5-1. For UL file number, see the product label. UL approval CCN LZGH2/8 which covers flame arrest-protected components for use in refrigeration and air-conditioning equipment employing A2L refrigerants, which are constructed so that, under normal or expected abnormal end-product operating conditions.
	The CSA/cUL approval is for drives of voltage rated at 600 V or lower. Compliance with the relevant UL/CSA standard makes sure that safety design together with relevant information and markings, ensures that when the drive is installed and maintained according to the provided operating or installation guide, the equipment meets the UL standards for electrical and thermal safety. This mark shows that the product complies with all required engineering specifications and testing. A certificate of compliance is provided on request.
	The drive complies with relevant regulation and their related standards for Great Britain. UKCA contact information: Danfoss, 22 Wycombe End, HP9 1NB, Great Britain
	The RCM Mark label indicates compliance with the applicable technical standards for Electromagnetic Compatibility (EMC). An RCM Mark label is required for placing electrical and electronic devices on the market in Australia and New Zealand. The RCM Mark regulatory arrangements only deal with conducted and radiated emission. For drives, the emission limits specified in EN/IEC 61800-3 apply. A declaration of conformity can be provided on request.
	The drive complies with relevant directives and their related standards for the Morocco market. Download the French product guides from .
	The Korea Certification (KC) Mark indicates that the product conforms to relevant Korean standards.

Table 4: EU Directives Applicable to Drives

EU Directive	Description
Low Voltage Directive (2014/35/EU)	The aim of the Low Voltage Directive is to protect persons, domestic animals, and property against dangers caused by the electrical equipment, when operating electrical equipment that is installed and maintained correctly, in its intended application. The directive applies to all electrical equipment in the 50–1000 V AC and the 75–1500 V DC voltage ranges.
EMC Directive (2014/30/EU)	The purpose of the EMC (electromagnetic compatibility) Directive is to reduce electromagnetic interference and enhance immunity of electrical equipment and installations. The basic protection requirement of the EMC Directive states that devices that generate electromagnetic interference (EMI), or whose operation could be affected by EMI, must be designed to limit the generation of electromagnetic interference and shall have a suitable degree of immunity to EMI when properly installed, maintained, and used as intended. Electrical equipment devices used alone or as part of a system must bear the CE mark. Systems do not require the CE mark, but must comply with the basic protection requirements of the EMC Directive.
ErP Directive (2009/125/EC)	The ErP Directive is the European Ecodesign Directive for energy-related products. The directive sets ecodesign requirements for energy-related products, including drives, and aims at reducing the energy consumption and environmental impact of products by establishing minimum energy-efficiency standards.
RoHS Directive (2011/65/EU)	The Restriction of Hazardous Substances (RoHS) Directive is an EU directive that restricts the use of hazardous materials in the manufacturing of electronic and electrical products. Read more on www.danfoss.com .
Waste Electrical and Electronic Equipment Directive (2012/19/EU)	The Waste Electrical and Electronic Equipment Directive (WEEE Directive) sets collection, recycling and recovery targets for all types of electrical goods.



2.2 Standards

Installation must be in accordance with national regulations, for example NEC NFPA 70, or IEC 60364 series of standards.

The following standards are recommended as guidelines for the installation and operation of drives:

- **EN IEC 61800-2: 2021 Adjustable speed electrical power drive systems - Part 2:** General requirements - Rating specifications for low voltage adjustable speed AC power drive systems.
- **EN IEC 61800-3: 2018 Adjustable speed electrical power drive systems - Part 3:** EMC requirements and specific test methods.
- **EN IEC 61800-5-1: 2021 Adjustable speed electrical power drive systems - Part 5-1:** Safety requirements - Electrical, thermal, and energy.
- **EN IEC 61800-9-2: 2023 Adjustable speed electrical power drive systems - Part 9-2:** Ecodesign for power drive systems, motor starters, power electronics and their driven applications - Energy efficiency indicators for power drive systems and motor starters.
- **EN IEC UL 60335-2-40: 2022 Household and similar electrical appliances - Part 2-40:** Particular requirements for electrical heat pumps, air-conditioners and dehumidifiers - Annex JJ, Allowable opening of relays and similar components to prevent ignition of A2L refrigerants.

Declarations of conformity are available at www.danfoss.com/en/service-and-support/documentation/.

2.3 Export Control Regulation

AC drives can be subject to regional and/or national export control regulations. Both the EU and US have regulations for so-called dual-use products (products for both military and non-military use), which currently includes AC drives with a capacity to operate from 600 Hz upwards. These products can still be sold, but it requires a set of measures, for example a license, or an end-user statement.

The US also has regulations for AC drives with a capacity to operate 300–600 Hz with restrictions on sales for certain countries. US regulations apply to all products manufactured in the US, exported from or via the US, or with a US content of more than 25%, or 10% for some countries. An ECCN number is used to classify all AC drives that are subject to export control regulations. The ECCN number is provided in the documentation accompanying the AC drive. If the AC drive is re-exported, it is the responsibility of the exporter to ensure compliance with the relevant export control regulations.

For further information, contact Danfoss.

3 iC2-Micro Frequency Converters

3.1 Intended Use

The drive is an electronic motor controller intended for:

- Regulation of motor speed in response to system feedback or to remote commands from external controllers. A power drive system consists of the drive and the motor.
- System and motor status surveillance.

The drive can also be used for motor overload protection.

Depending on the configuration, the drive can be used in standalone applications or form part of a larger appliance or installation.

The drive is allowed for use in residential, industrial, and commercial environments in accordance with local laws and standards.

NOTICE

In a residential environment, this product can cause radio interference, in which case supplementary mitigation measures can be required.

Foreseeable misuse

Do not use the drive in applications which are non-compliant with specified operating conditions and environments. Ensure compliance with the conditions specified in *chapter Specifications*.

3.2 Block Diagram

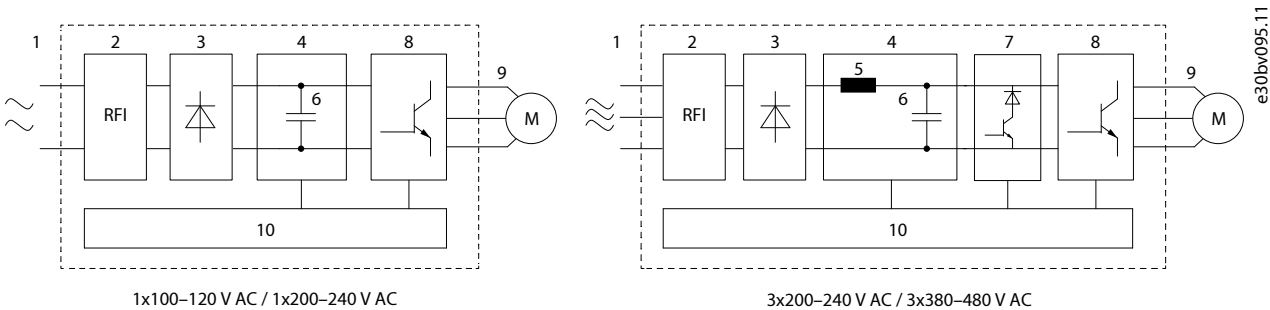

Figure 1: Block Diagram of iC2-Micro Frequency Converters

Table 5: Functions of Each Component

Area	Component	Functions
1	Mains input	AC mains supply to the drive.
2	RFI filter	RFI filter is used to meet the regulatory requirements of electromagnetic compatibility.
3	Rectifier	The rectifier bridge converts the AC input to DC current to supply inverter power.
4	DC bus	Intermediate DC bus circuit handles the DC current.
5	DC reactor ⁽¹⁾	<ul style="list-style-type: none"> • Filters the DC-link current. • Provides mains transient protection. • Reduces the root mean square (RMS) current. • Raises the power factor reflected back to the line. • Reduces harmonics on the AC input.

Table 5: Functions of Each Component (continued)

Area	Component	Functions
6	Capacitor bank	<ul style="list-style-type: none"> Stores the DC power. Provides ride-through protection for short power losses.
7	Brake chopper ⁽²⁾	Brake chopper is used in the DC link to control DC voltage when the load feeds energy back.
8	Inverter	Converts the DC into a controlled PWM AC waveform for a controlled variable output to the motor.
9	Output to motor	Regulated 3-phase output power to the motor.
10	Control circuitry	<ul style="list-style-type: none"> Input power, internal processing, output, and motor current are monitored to provide efficient operation and control. User interface and external commands are monitored and performed. Status output and control can be provided.

1) DC reactor is only applicable to enclosure size MA05a.

2) Brake chopper is not applicable to enclosure size MA01a.

3.3 Ecodesign for Power Drive Systems

3.3.1 Overview

Energy-efficiency of the overall system is important and compliance with relevant legislation is required in the extended single market in the European Economic Area.

Frequency converters are classified by efficiency classes IE0 to IE2 according to IEC 61800-9-2 and EN 50598-2. According to the standard, power losses are measured as percentages of the rated apparent output power at 8 load points as shown in [Figure 2](#). Together with information about other elements of the system, this information can be used to calculate a system level efficiency (IES).

Elements causing losses are described in [3.3.2 Power Losses and Efficiency](#).

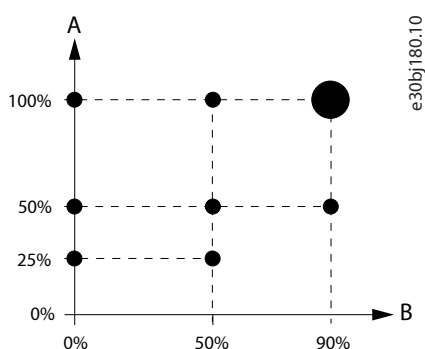
Figure 2: Operating Point According to IEC 61800-9-2 (EN 50598)

The frequency converter is labeled with the efficiency class and the power losses at 100% rated torque-producing current and 90% rated motor stator frequency.

[MyDrive® ecoSmart™](#) can be used to:

- Look up part load data as defined in IEC 61800-9-2.
- Calculate the efficiency class and part load efficiency for the frequency converter and the Power Drive System.
- Create a report documenting part load loss data and IE and IES efficiency class.

3.3.2 Power Losses and Efficiency

Elements causing power loss in the system are shown in [Figure 3](#).

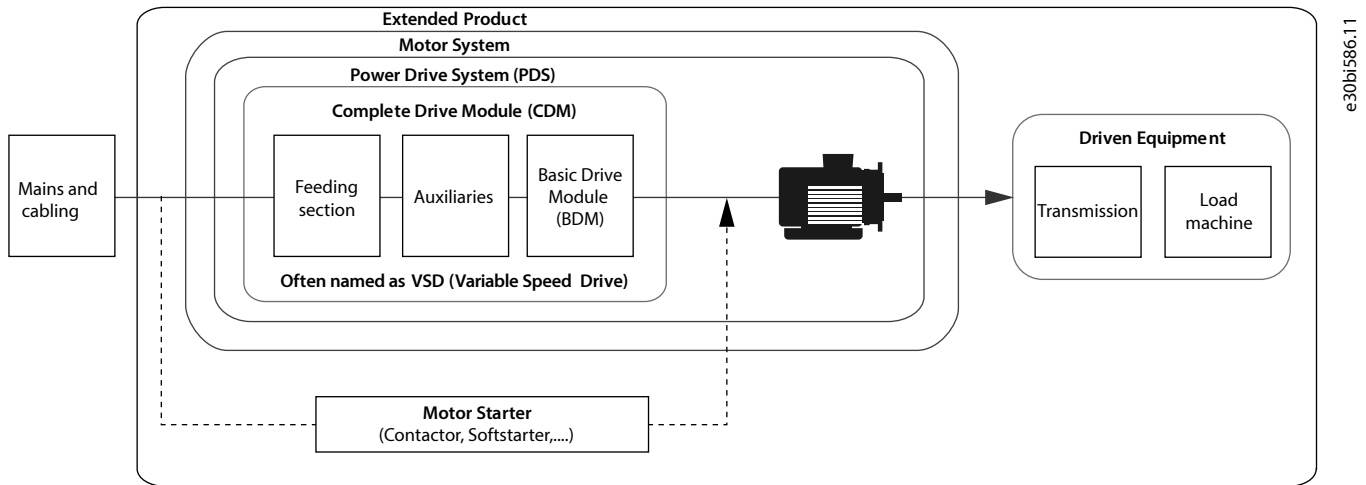

Figure 3: Drive System Design

The following components can cause losses in the system:

- Mains supply cable.
- External input filter (if installed).
- Frequency converter, including built-in filters.
- External output filter (if installed).
- Motor cable.
- Motor.

The frequency converter itself only provides a part of the total losses of the system.

Mains supply cable

Losses in the mains supply cable are mainly caused by the ohmic resistance of the cable. To keep the losses at a minimum, the cable length should be kept short and sized properly to the rated current.

External input filter

Externally added input filters add to the losses in the system. Line reactors used to balance the load between multiple drives in a load sharing setup typically have a voltage drop of approximately 1%, causing up to 1% losses at full load.

Dedicated harmonic filters typically have losses of 2–5%.

Frequency converter

The loss of the frequency converter is load-dependent. Specific classifications and power loss data are shown on the product label, and details can be seen in [MyDrive® ecoSmart™](#).

External output filter

Externally connected output filters add losses to the system:

- Sine-wave filters suppress the PWM pattern of the output frequency, resulting in a sine wave output. The resulting loss is load dependent and can be up to 1–1.5% of maximum power. Using a sine-wave filter in installations with long motor cables can result in a better overall efficiency.
- dU/dt filters limit the voltage rise time of the PWM pattern. As a result, the filters introduce loss in the system – Loss is load dependent and can be up to 0.5-1% of maximum power.

- Common-mode cores mitigate high-frequency noise in the motor cable. As a result, limited loss is added to the system.

Motor cable

Losses in the motor cable are mainly caused by ohmic losses, but due to the switching frequency of the frequency converter, losses are also caused by capacitive coupling to ground. Losses due to capacitive coupling can be reduced by carefully selecting the motor cable and keeping the cable length as short as possible. If a sine-wave filter is used on the frequency converter output, the loss caused by capacitive load is lower.

Motor

Motor losses depend on the motor type and efficiency category selected. IEC60034-30-1 defines the different efficiency classes from IE1 to IE4.

3.4 Power Hardware

iC2-Micro Frequency Converters are designed to fit a wide variety of installation locations. The units are available in different protection ratings, making them suitable for installation in cabinets, directly on machines, in dedicated control rooms, and freely installed.

- IP20/Open Type is designed for installation in enclosed cabinets and similar setups.
- IP21/UL Type 1 (IP21/Type 1 conversion kit as an option) is designed for indoor installations.

iC2-Micro Frequency Converters are suitable for use in a wide temperature range. The operating temperature range is from -20 °C to +55 °C (-4 °F to +131 °F) and -10 °C to +50 °C (14 °F to +122 °F) without derating.

The motor output of the iC2-Micro Frequency Converters is protected against short circuit, ground fault, and overload. Thermal monitoring is also provided to protect the motor. Unlimited switching on output enables using a contactor or disconnects between the drive and the motor.

Integrated filters optimize EMC performance, reduce harmonics on the grid, and match with output requirements. Built-in EMC filters can be configured to fit the EMC-related installation requirements. The offering covers:

- Drives without filter (C4 compliant variants).
- Drives with filters for use in industrial networks (C2 compliant variants) and domestic installations (C1 compliant variants).

3.5 Control and Interfaces

3.5.1 Control Terminals

- All control cable terminals are located underneath the terminal cover in front of the drive.
- See the back of the terminal cover for outlines of control terminals and switches.

NOTICE

- Remove the terminal cover with a screwdriver, see [Figure 4](#).

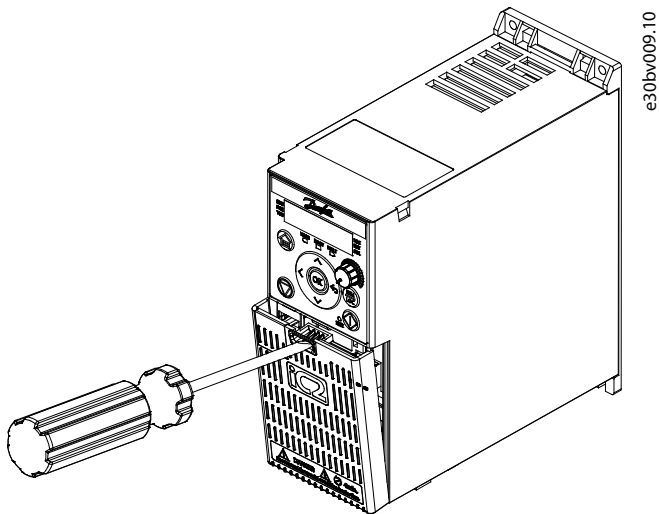

Figure 4: Removing Terminal Cover

All control terminals of iC2-Micro Frequency Converters are shown in [Figure 5](#).

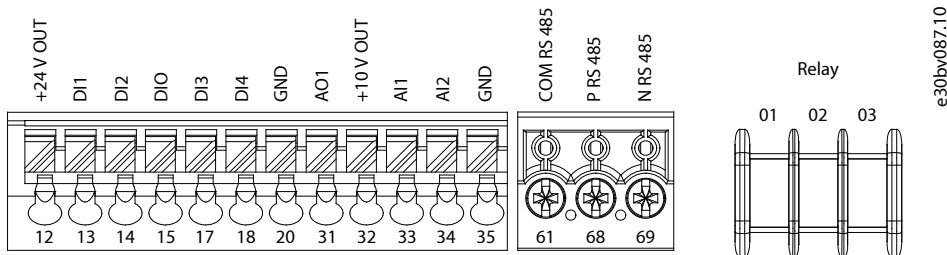

Figure 5: Overview of Control Terminals

3.5.2 RJ45 Port and RS485 Termination Switch

The drive has an RJ45 port which complies with Modbus 485 protocol. The RJ45 port is used for connecting:

- External control panel (Control Panel 2.0 OP2)
- PC tool (MyDrive® Insight) via Quick Adapter USB-C/RJ45 OAX00

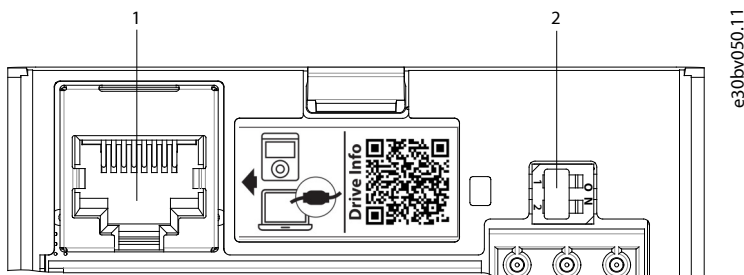

Figure 6: RJ45 Port and RS485 Termination Switch

1	RJ45 port	2	RS485 termination switch (ON=RS485 terminated, OFF=Open)
---	-----------	---	--

NOTICE

The RJ45 port supports up to 3 m (9.8 ft) of shielded CAT5e cable which is **NOT** used to directly connect the drive to a PC. Failure to follow this notice causes damage to the PC.

NOTICE

- RS485 termination switch should be set to ON if the drive is at the end of the fieldbus.
- Do not operate RS485 termination switch when the drive is powered on.

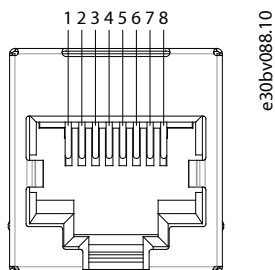

Figure 7: Pin Definition of RJ45

1	5 V power supply	2	5 V power supply
3	GND	4	RS485_P
5	RS485_N	6	GND
7	Reserved	8	Reserved

3.5.3 Control Panel and Control Panel 2.0 OP2

The drive has 2 types of control panels as follows:

- **Control Panel:** It is inbuilt and by default delivered with the drive. The Control Panel buttons and indicators are described in [3.5.4 Control Panel Buttons and Indicators](#).
- **Control Panel 2.0 OP2:** An optional (accessory) control panel which provides better user experience. This type of control panel enables easy setup of the drive via parameters, monitoring of the drive status, and visualization of event notifications. The Control Panel 2.0 OP2 buttons and indicators are described in [3.5.5 Control Panel 2.0 OP2 Buttons and Indicators](#).

A more detailed overview of Control Panel 2.0 OP2 is as follows:

- 2.03" monochromatic user interface.
- Visual LEDs to identify drive status.
- Control of the drive and easy switch between local and remote operations.
- Multilingual display which shows parameters, selections, and status more clearly.
- Parameter display supports alphanumeric, special characters, integers, floating points, choice lists, and commands to configure application data.
- Parameter settings of the drive can be copied to other drives for easy commissioning.
- Installation on a cabinet door using a mounting kit option.

3.5.4 Control Panel Buttons and Indicators

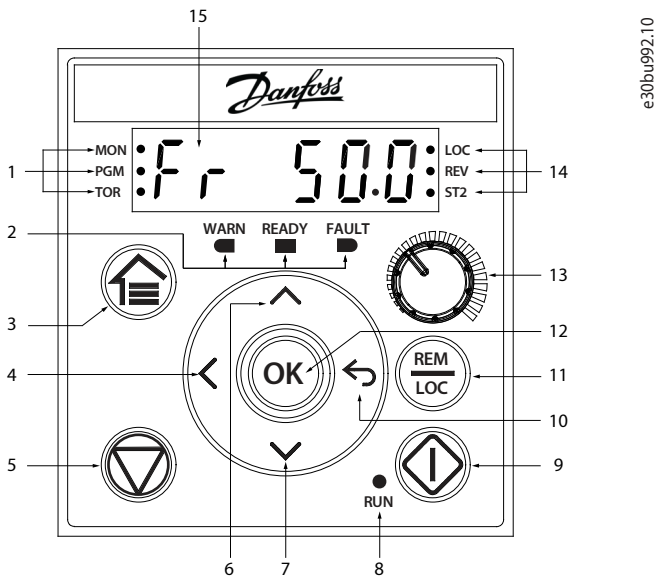

Figure 8: Control Panel

1	Status indicators	2	Operating indicators
3	Home/Menu	4	Left
5	Stop/Reset	6	Up
7	Down	8	Run indicator
9	Start	10	Back
11	Remote/Local	12	OK
13	Potentiometer	14	Status indicators
15	Main display		

Table 6: Operation Buttons and Potentiometer

Name	Function
Home/Menu	Toggles between status view and main menu. Long press to access the shortcut menu for quickly reading and editing parameters.
Up/Down	Switches status/parameter group/parameter numbers, and tunes the parameter values.
Left	Moves the cursor 1 bit to the left.
Back	Navigates to the previous step in the menu structure or cancels the setting during tuning parameter values.
OK	Confirms the operation.
Remote/Local	Toggles between the remote mode and local mode.
Start	Starts the drive in local mode.

Table 6: Operation Buttons and Potentiometer (continued)

Name	Function
Stop/Reset	Stops the drive in local mode.
	Resets the drive to clear a fault.
Potentiometer	Changes the reference value when the reference value is selected as potentiometer.

Table 7: Status Indicator Lights

Name	Function
MON	On: The main display is showing the drive status.
PGM	On: The drive is in programming status.
TOR	On: The drive is in torque mode.
	Off: The drive is in speed mode.
LOC	On: The drive is in local mode.
	Off: The drive is in remote mode.
REV	On: The drive is in reverse direction.
	Off: The drive is in forward direction.
ST2	Refer to Table 10 .

Table 8: Operating Indicator Lights

Name	Function
WARN	Steadily lit when a warning occurs.
READY	Steadily lit when the drive is ready.
FAULT	Flashes when a fault occurs.

Table 9: Run Indicator Light

Name	Function
RUN	On: The drive is in normal operation.
	Off: The drive has stopped.
	Flash: In the motor-stopping process; or the drive received a <i>RUN</i> command, but no frequency output.

Table 10: Multiple Setups Indicator Light

ST2	Off	On	Flash	Flash quickly
Active setup ⁽¹⁾	Setup 1	Setup 2	Setup 1	Setup 2
Programming setup ⁽²⁾	Setup 1	Setup 2	Setup 2	Setup 1

1) Select active setup in parameter P 6.6.1 Active Setup.

2) Select programming setup in parameter P 6.6.2 Active Setup.

3.5.5 Control Panel 2.0 OP2 Buttons and Indicators

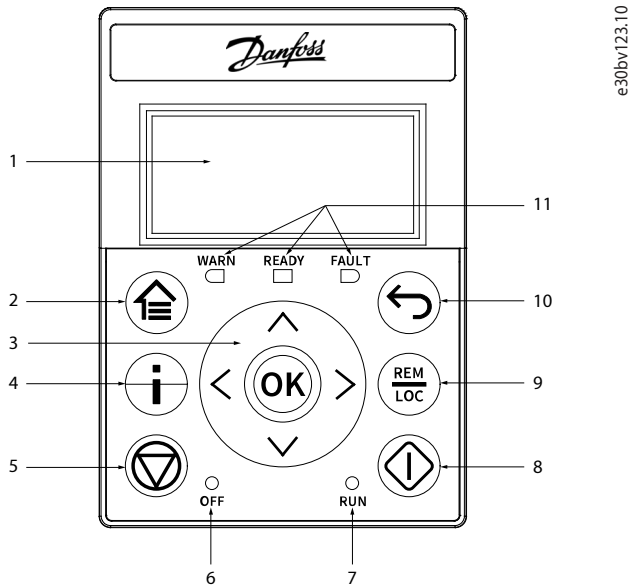

e30by123.10

Figure 9: Control Panel 2.0 OP2 Overview

Table 11: Control Panel Elements Description

Legend	Name of element	Description
1	Display	Provides access to content and settings. The display provides detailed information about the status of the drive.
2	Home/Menu	<ul style="list-style-type: none"> • Toggles between status view and main menu. • Long press to access the shortcut menu for quickly reading and editing parameters.
3	Arrows and [OK]	<ul style="list-style-type: none"> • Arrows: Navigate within the different screens and menus, and tune the parameter values. • [OK]: Confirms selections and data in the control panel display.
4	Info	Provides drive information by pressing the <i>Info</i> button from the home screen, for example, the drive type, ordered model code, drive serial number, application version.
5	Stop/Reset	Stops the operation of the drive.
6	OFF LED	The indicator has the following states: <ul style="list-style-type: none"> • Steady on: The indicator is in this state when: <ul style="list-style-type: none"> - The drive is not modulating and the drive is coasted. - The stop or coast signal is applied. Ramp times, protections, and stopping functions might prolong this state. • Off: The drive is in operation, a start signal is applied, and the output is active. This also includes ramping, running on reference, and AMA.

Table 11: Control Panel Elements Description (continued)

Legend	Name of element	Description
7	RUN LED	The indicator has the following states: <ul style="list-style-type: none"> • On: The drive is in normal operation. • Off: The drive has stopped. • Flash: The indicator is in this state when: <ul style="list-style-type: none"> - In the motor-stopping process (ramp down). - The drive received a <i>RUN</i> command, but no frequency output.
8	Run	Starts the operation of the drive.
9	REM/LOC	Toggles the drive between remote and local operation.
10	Back	Navigates to previously viewed screen or a menu level above the current menu.
11	Drive Status Indicators	The related LEDs indicate the status of the drive. <ul style="list-style-type: none"> • [WARN]: A steady yellow light indicates a warning. • [READY]: A steady green light indicates that the drive is ready. • [FAULT]: A flashing red light indicates a fault.

3.5.6 Sliding Door on the Terminal Cover

A sliding door, which is the protective cover of the RJ45 port, is designed on the terminal cover of the drive. When the drive is connected with the Control Panel 2.0 OP2 option, which can be installed on the cabinet door, remove the sliding door to ensure that the terminal cover remains on the drive to ensure safe operation.

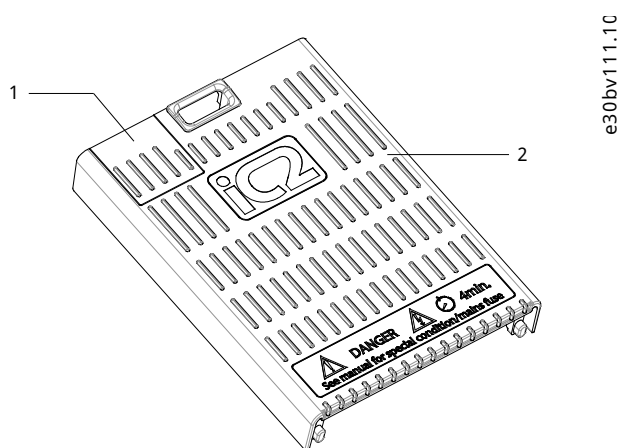

Figure 10: Sliding Door on the Terminal Cover

1	Sliding door	2	Terminal cover
---	--------------	---	----------------

Disassembly

1. Remove the terminal cover with a screwdriver, see [3.5.1 Control Terminals](#).
2. From the inner side of the terminal cover, press the slot with a screwdriver to release the sliding door and slide it out.

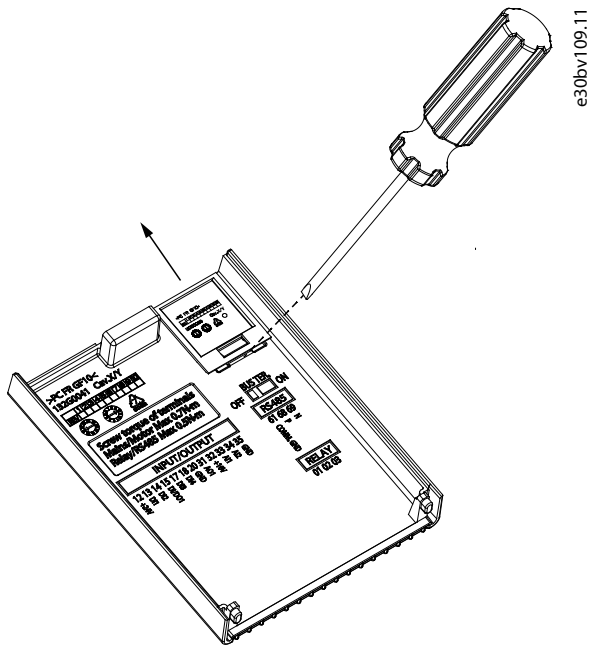

Figure 11: Removing the Sliding Door

Reassembly

1. Slide the sliding door into the terminal cover.

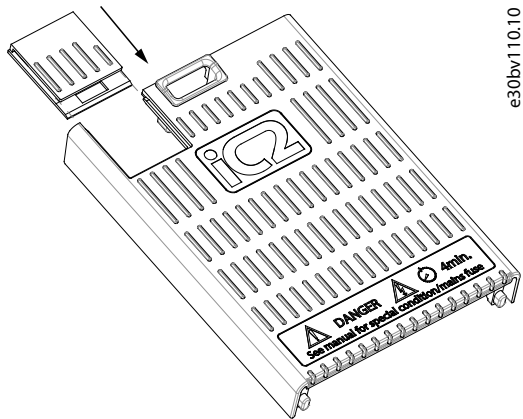

Figure 12: Installing the Sliding Door

3.6 Application Software

3.6.1 iC2-Micro Application Software Overview

The application software is the default and standard software delivered with the iC2-Micro Frequency Converters. The features are briefly described in the following sections:

- Basic Functions
- Controllers
- Protection Features
- Software Tools

3.6.2 Basic Functions

3.6.2.1 Basic Functions Overview

The application software consists of a wide range of basic features which enables the drive to control any application using the iC2-Micro drive.

3.6.2.2 Reference Handling

References from multiple sources, matching the needs to control the application, are freely definable.

Reference sources are:

- Analog inputs
- Digital inputs either as pulse input
- Reference from a fieldbus
- Internal settings
- Local reference from control panel
- Built-in potentiometer on control panel

Reference signals can be added generating the reference to the frequency converter. The final reference is scaled from -100% to 100%.

3.6.2.3 Two Setups

The frequency converter offers 2 setups. Each setup can be parameterized independently to match various application needs.

Switching between setups is possible during operation, allowing fast changeover.

3.6.2.4 Ramps

Linear, Sine ramp, Sine 2 ramps are supported in the frequency converter. The linear ramps provide a constant acceleration. The Sine ramps provides a non-linear acceleration with soft transition at start and end of the acceleration process.

3.6.2.5 Quick Stop

In some situations, it may be required to stop the application in a quick way. For this purpose, the drive supports a specific deceleration ramp time from the synchronous motor speed to 0 RPM.

3.6.2.6 Limit Rotation Direction

The rotational direction of the motor can be preset to run in 1 direction only (clockwise or counterclockwise), avoiding unintended rotation direction.

3.6.2.7 Motor Phase Switch

If motor phase cables have been installed in an incorrect order during installation, the rotation direction can be changed. This eliminates the need to change the order of motor phases.

3.6.2.8 Inching with Jogging Modes

The frequency converter has predefined speed settings for use during commissioning, maintenance, or service. The jogging-mode operation is set at preset speed.

3.6.2.9 Frequency Bypass

Specific motor frequencies can be bypassed during operation. The feature helps to minimize and avoid mechanical resonance of the machine, limiting vibration and noise of the system.

3.6.2.10 Automatic Restart

In case of a minor fault and trip, the drive can do an automatic restart, eliminating a manual reset of the drive. This enhances automated operation in remotely controlled systems. Make sure that dangerous situations cannot occur when using automatic restart.

3.6.2.11 Flying Start

Flying start enables the drive to synchronize to a freely spinning motor, before taking control of the motor. Taking over control of the motor at the actual speed minimizes mechanical stress to the system. For example, the feature is relevant in fan and centrifuge applications.

3.6.2.12 Mains Dropout

In case of mains dropout, where the drive cannot continue operation, it is possible to select predefined actions, for example trip, coast, or performing a controlled ramp down.

3.6.2.13 Kinetic Backup

Kinetic backup enables the drive to remain in control if there is sufficient energy in the system, for example, as inertia or when lowering a load. This allows a controlled stop of the machine.

3.6.2.14 Resonance Damping

High-frequency motor resonance noise can be eliminated through the use of resonance damping. Both automatic and manually selected frequency damping are available.

3.6.2.15 Mechanical Brake Control

In applications like simple hoists, palletizers, stereoscopic warehouse, or downhill conveyors, a mechanical brake is used to keep the load at standstill, when the motor is not controlled by the drive or when power is turned off.

The mechanical brake control feature ensures a smooth transition between the mechanical brake and motor holding the load by controlling the activation and deactivation of the mechanical brake.

3.6.2.16 Controllers

The drive has 3 different controllers providing optimized control of the actual application. The controllers cover:

- Process control
- Speed control open loop
- Torque control open loop

Process controller

The process controller can control a process, for example, in a system where a constant pressure, flow, or temperature is needed. Feedback from the application is connected to the drive, providing the actual output value. The controller ensures that the output is matching the reference provided by controlling the motor speed. The reference source and the feedback signals are converted and scaled to the actual values controlled.

Speed controller

The open-loop speed control provides accurate control of the motors rotational speed.

In open-loop mode (without external feedback signal of the speed), there is no need for external sensors. The open-loop speed control makes installation and commissioning easier, and eliminates the risk of defective sensors.

Torque controller

A built-in torque controller provides optimized control of torque and supports open-loop control.

3.6.3 IO Control and Readouts

Depending on the hardware configuration of the drive, digital and analog inputs, digital and analog outputs, and relay outputs are available. The I/Os can be configured and used to control the application from the drive.

All I/Os can be used as remote I/O nodes, as they are all addressed by the fieldbus of the drive.

3.6.4 Motor Control Features

3.6.4.1 Motor Control Features Overview

The motor control covers a wide range of applications, control from the most basic applications to applications requiring high-performance motor control.

3.6.4.2 Motor Types

The drive supports standard available motors like:

- Induction motors
- Permanent magnet motors

3.6.4.3 Load Characteristics

Different load characteristics are supported to match the actual application needs:

- **Variable torque:** Typical load characteristic of fans and centrifugal pumps, where the load is proportional to the square of the speed.
- **Constant torque:** Load characteristic used in machinery where torque is needed across the full speed range. Typical application examples are conveyors, extruders, decanters, compressors, and winches.

3.6.4.4 Motor Control Principle

Different control principles can be selected to control the motor, matching the application needs:

- U/f control for special control
- VVC+ control for the general-purpose application needs

3.6.4.5 Motor Nameplate and Catalog

Typical motor data for the actual drive are preset from factory, allowing operation of most motors. During commissioning, actual motor data are entered in the settings of the drive, optimizing the motor control.

3.6.4.6 Automatic Motor Adaptation (AMA)

Automatic Motor Adaptation (AMA) provides optimization of motor parameters for improved shaft performance. Based on motor nameplate data and measurements of the motor at standstill, key motor parameters are being recalculated and used to fine tune the motor control algorithm.

3.6.4.7 Automation Energy Optimization (AEO)

The Automatic Energy Optimizer (AEO) feature optimizes the control with focus on lowering energy consumption at the actual load point.

3.6.5 Braking of Load

3.6.5.1 Braking of Load Overview

When braking the motor controlled by the drive, various functions can be used. The specific function is selected based on the application and the needs for how fast it should be stopped.

3.6.5.2 Resistor Braking

In applications where fast or continuous braking is required, a drive fit with a brake chopper is typically used. Excess energy generated by the motor during braking of the application will be dissipated in a connected brake resistor. Braking performance depends on the specific drive rating and selected brake resistor.

3.6.5.3 Overvoltage Control (OVC)

If braking time is not critical or the load is varying, the overvoltage control (OVC) feature is used to control stopping the application. The drive extends the ramp-down time when it is not possible to brake within the defined ramp-down period. The feature should not be used in hoisting applications, high-inertia systems, or where continuous braking is required.

3.6.5.4 DC Brake

When braking at low speed, the braking of the motor can be improved by using the DC brake feature. It adds a small DC current on top of the AC current, slightly increasing the brake capability.

3.6.5.5 AC Brake

In applications with non-cyclic operation of the motor, AC braking can be used to shorten the braking time and is only supported for induction motors. Excess energy is dissipated by increasing losses in the motor during braking.

3.6.5.6 DC Hold

DC hold provides a limited holding torque on the rotor at standstill.

3.6.5.7 Load Sharing

In some applications, 2 or more drives are controlling the application at the same time. If 1 of the drives is braking a motor, the excess energy can be fed to the DC link of a drive driving a motor, with a reduction of the total energy consumption. This feature is useful in, for examples, decanters and carding machines, where smaller power-sized drives operate in generator mode.

3.6.6 Protection Features

3.6.6.1 Grid Protections

The drive protects against conditions on the power grid that can affect proper operation.

The grid is monitored for phase imbalance and phase loss. If the imbalance exceeds internal limits, a warning is provided and the user can initiate proper actions.

In case of an under- or overvoltage on the grid, the drive will provide a warning and stop operation if the situation remains or exceeds critical limits.

3.6.6.2 Drive Protection Features

The drive is monitored and protected during operation.

Inbuilt temperature sensors measure the actual temperature and provide relevant information to protect the drive. If the temperature exceeds its nominal temperature conditions, derating will be applied. If the temperature is outside the allowed operating range, the drive will stop operation.

The motor current is continuously monitored on all 3 phases. In case of a short circuit between 2 phases or a fault to ground, the drive will detect this and immediately turn off. If the output current is exceeding its nominal values during operation for longer periods than allowed, the drive will stop and report overload alarm.

The DC-link voltage of the drive is monitored. If it exceeds critical levels, a warning is issued and the drive will stop. If the situation is not resolved, the drive will issue an alarm.

3.6.6.3 Motor Protection Features

The drive provides various features to protect the motor and the application.

The output current measurement provides information to protect the motor. Overcurrent, short circuit, ground faults, and lost motor phase connections can be detected and relevant protections initiated.

Monitoring of speed, current, and torque limits provides an additional protection of the motor and the application.

Locked rotor protection secures that the drive is not starting with a blocked rotor of the motor.

Motor thermal protection is provided either as a calculation of the motor temperature based on the actual load or by the means of external temperature sensors, for example PTC.

3.6.6.4 Protection of Externally Connected Components

Externally connected options like brake resistors can be monitored.

Brake resistors are monitored for thermal overload, short circuit, and missing connection.

3.6.6.5 Automatic Derating

Automatic derating of the drive allows continued operation even if the nominal operation conditions are exceeded. Typical factors affecting this are temperature, high DC-link voltage, high motor load, or operation close to 0 Hz. Derating is typically applied as a reduction in switching frequency or change in switching pattern, resulting in lower thermal losses.

3.6.7 Monitoring Features

3.6.7.1 Monitoring Features Overview

The drive offers a wide range of monitoring features providing information of operation conditions, grid conditions, and drive historical data. Access to this information helps out analyzing operational conditions and identification of faults.

3.6.7.2 Speed Monitoring

The motor speed can be monitored during operation. If the speed exceeds minimum and maximum limits, the user is notified and can initiate appropriate actions.

3.6.7.3 Event Log and Operational Counters

An event log provides access the latest registered faults, providing relevant information for analysis of what occurred in the drive.

Operational counters offer information about the drive usage. Values like operation hours, running hours, kWh used, number of power-ups, overvoltages, and overtemperatures are examples of the readouts available.

3.6.8 Software Tools

3.6.8.1 Software Tools Overview

Danfoss offers a suite of desktop software tools which have been designed to provide easy operation and the highest level of customization of AC drives.

APIs and the Danfoss Device Interface enable integration of the tools into proprietary systems and business processes. The MyDrive® tools support the entire life cycle of the drive, from system design to service. Some of the tools are available free of charge, and some require a subscription.

For more information about the MyDrive® tools, see MyDrive documentation.

3.6.8.2 MyDrive® Select

MyDrive® Select performs frequency converter sizing based on calculated motor load currents, ambient temperature, and current limitations. The sizing results are available in graphical and numerical format, and include calculations of efficiency, power losses, and inverter load currents. The resulting documentation is available in .pdf or .xls format, and can be imported to MyDrive® Harmonics for evaluation of the harmonic distortion, or validation of compliance towards most recognized harmonic norms and recommendations.

MyDrive® Select is available as a web-based tool at select.mydrive.danfoss.com and as a mobile device app that can be downloaded from app stores.

3.6.8.3 MyDrive® Harmonics

MyDrive® Harmonics estimate the benefits of adding harmonic mitigation solutions to an installation and calculates system harmonic distortion. The evaluation can be done both for new installations and when extending an existing installation.

The free version provides a fast overview of the expected general performance of the system. The expert version of MyDrive® Harmonics requires a subscription, which opens up more features, including the possibility to save and share harmonic projects, import projects from MyDrive® Select, and the possibility to add Danfoss harmonic mitigation products.

3.6.8.4 MyDrive® ecoSmart™

MyDrive® ecoSmart™ determines the energy efficiency of the drive being used and the system efficiency class according to IEC 61800-9.

MyDrive® ecoSmart™ uses information about the selected motor, load points, and AC drive to calculate the efficiency class and part load efficiency for a Danfoss AC drive, either for a free-standing drive (CDM), or a drive with a motor (PDS).

MyDrive® ecoSmart™ is available as a web-based tool at ecosmart.mydrive.danfoss.com and as a mobile device app that can be downloaded from app stores.

3.6.8.5 MyDrive® Insight

MyDrive® Insight is a software tool for commissioning, engineering, and monitoring drives. MyDrive® Insight can be used to configure parameters, upgrade software, and set up functional safety features and condition-based monitoring.

Making backups, restoring the system from a backup, and data logging within MyDrive® Insight support the use of a microSD card as storage device.

3.7 Brake Functions

3.7.1 Mechanical Holding Brake

A mechanical holding brake mounted directly on the motor shaft normally performs static braking.

NOTICE

When the holding brake is included in a safety chain, a drive cannot provide a safe control of a mechanical brake.

- Include a redundancy circuitry for the brake control in the total installation.

3.7.2 Dynamic Braking

Dynamic braking is established by:

- Resistor brake: A brake IGBT keeps the overvoltage under a certain threshold by directing the brake energy from the motor to the connected brake resistor (*parameter P 3.2.1 Enable Brake Chopper = [1] Enable*). Adjust the threshold in *parameter P 3.2.2 Brake Chopper Voltage Reduce*, with 70 V range for 3x380–480 V.
- AC brake: The brake energy is distributed in the motor by changing the loss conditions in the motor. The AC brake function cannot be used in applications with high-cycling frequency as this overheats the motor (*parameter P 3.2.1 Enable Brake Chopper = [1] Enable*).

- DC brake: An overmodulated DC current added to the AC current works as an eddy current brake (*parameter P 5.7.3 DC Brake Time* ≠ 0 s).

3.7.3 Brake Resistor Selection

3.7.3.1 Introduction

To handle higher demands by generative braking, a brake resistor is necessary. Using a brake resistor ensures that the heat is absorbed in the brake resistor and not in the drive.

If the amount of kinetic energy transferred to the resistor in each braking period is not known, calculate the average power based on the cycle time and braking time. The resistor intermittent duty cycle is an indication of the duty cycle at which the resistor is active. A typical braking cycle is shown in [Figure 13](#).

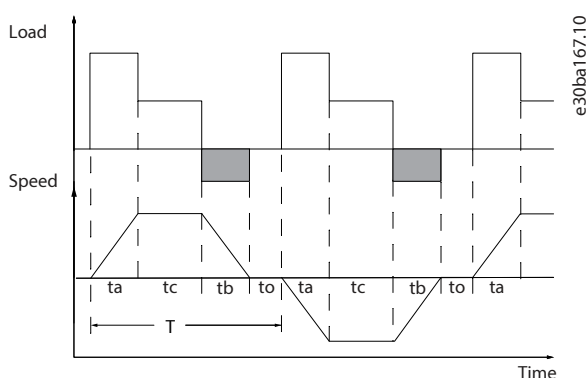

Figure 13: Typical Braking Cycle

The intermittent duty cycle for the resistor is calculated as follows:

$$\text{Duty cycle} = t_b / T$$

t_b is the braking time in seconds.

T = cycle time in seconds.

Table 12: Braking at High Overload Torque Level

Cycle time (s)	120
Braking duty cycle at 100% torque	Continuous
Braking duty cycle at overtorque (150/160%)	40%

Danfoss offers brake resistors with duty cycles of 10% and 40%. If a 10% duty cycle is applied, the brake resistors are able to absorb brake power for 10% of the cycle time. The remaining 90% of the cycle time is used for dissipating excess heat.

NOTICE

Make sure that the resistor is designed to handle the required braking time.

3.7.3.2 Brake Resistance Calculation

The maximum allowed load on the brake resistor is stated as a peak power at a given intermittent duty cycle and can be calculated as:

$$R_{br}[\Omega] = \frac{U_{dc,br}^2 \times 0.83}{P_{peak}}$$

where

$$P_{\text{peak}} = P_{\text{motor}} \times M_{\text{br}}[\%] \times \eta_{\text{motor}} \times \eta_{\text{VLT}}[W]$$

As shown, the brake resistance depends on the DC-link voltage (U_{dc}).

Table 13: Threshold of the Brake Resistance

Size	Brake active $U_{\text{dc,br}}$	Warning before cutout	Cutout (trip)
3x380–480 V	770 V	800 V	800 V

The threshold can be adjusted in *parameter P 3.2.2 Brake Chopper Voltage Reduce*, with 70 V range.

NOTICE

The greater the reduction value, the faster the reaction to a generator overload. Should only be used if there are problems with overvoltage in the DC-link voltage.

NOTICE

Make sure that the brake resistor can cope with a voltage of 800 V.

3.7.3.3 Danfoss Recommended Brake Resistance Calculation

Danfoss recommends calculating the brake resistance R_{rec} according to the following formula. The recommended brake resistance guarantees that the drive is able to brake at the highest braking torque ($M_{\text{br}(\%)}$) of 150%.

$$R_{\text{rec}}[\Omega] = \frac{U_{\text{dc}}^2 \times 100 \times 0.83}{P_{\text{motor}} \times M_{\text{br}(\%)} \times \eta_{\text{VLT}} \times \eta_{\text{motor}}}$$

η_{motor} is typically at 0.80 (≤ 7.5 kW/10 hp); 0.85 (11–22 kW/15–30 hp).

η_{VLT} is typically at 0.97.

For iC2-Micro Frequency Converters, R_{rec} at 150% braking torque is written as:

$$480V : R_{\text{rec}} = \frac{396349}{P_{\text{motor}}} [\Omega] \text{ for drives } \leq 7.5 \text{ kW (10 hp) shaft output.}$$

$$480V : R_{\text{rec}} = \frac{397903}{P_{\text{motor}}} [\Omega] \text{ for drives as 11–22 kW (15–30 hp) shaft output.}$$

NOTICE

The resistance of the brake resistor should not be higher than the value recommended by Danfoss. For brake resistors with a higher ohmic value, the 150% braking torque may not be achieved because the drive might cut out for safety reasons. The resistance should be bigger than R_{min} .

NOTICE

If a short circuit in the brake transistor occurs, prevent power dissipation in the brake resistor by using a mains switch or contactor to disconnect the mains for the drive. The drive can control the contactor.

NOTICE

Do not touch the brake resistor because it can get hot during braking. To avoid fire risk, place the brake resistor in a secure environment.

3.7.3.4 Control with Brake Function

The brake is protected against short-circuiting of the brake resistor, and the brake transistor is monitored to ensure that short-circuiting of the transistor is detected. A relay/digital output can be used for protecting the brake resistor from overloading caused by a fault in the drive.

In addition, the brake enables readout of the momentary power and the mean power for the latest 120 s. The brake can also monitor the power energizing and make sure that it does not exceed a limit selected in *parameter P 3.3.3 Brake Resistor Power Limit*.

WARNING

Monitoring the brake power is not a safety function. A thermal switch is required to avoid the brake power from exceeding the limit. The brake resistor circuit is not ground leakage protected.

Overvoltage control (OVC) (exclusive brake resistor) can be selected as an alternative brake function in *parameter P 2.3.1 Overvoltage Controller Enable*. This function is active for all units. The function ensures that a trip can be avoided if the DC-link voltage increases. This is done by increasing the output frequency to limit the voltage from the DC link. It is a useful function, for example, if the ramp-down time is too short to avoid tripping of the drive. In this situation, the ramp-down time is extended.

NOTICE

OVC can be activated when running a permanent magnet motor (when *parameter P 4.2.1.1 Motor Type* is set to [1] PM, Non-salient SPM).

4 Specifications

4.1 Electrical Data

4.1.1 Mains Supply 1x100–120 V AC

Table 14: Mains Supply 1x100–120 V AC

Normal overload 150% for 1 minute		
Frequency converter	02A4	04A8
Typical shaft output [kW]	0.37	1.1
Typical shaft output [hp]	0.5	1.5
Enclosure size	MA01c	MA02c
Output current		
Continuous (3x200–240 V AC) [A]	2.4	4.8
Intermittent (3x200–240 V AC) [A]	3.6	7.2
Maximum cable size		
(Mains, motor) [mm ² /AWG]	4/10	
Maximum input current		
Continuous (1x100–120 V) [A]	11.6	25.6
Intermittent (1x100–120 V) [A]	17.4	38.4
EMC filter type	C4	
Environment		
Power loss [W] ⁽¹⁾	18	24
Efficiency [%] ⁽¹⁾	97.4	98.2

1) The value is measured at 100% rated torque-producing current and 90% rated motor stator frequency according to IEC 61800-9-2 and EN 50598-2.

4.1.2 Mains Supply 1x200–240 V AC

Table 15: Mains Supply 1x200–240 V AC

Normal overload 150% for 1 minute				
Frequency converter	02A2	04A2	06A8	09A6
Typical shaft output [kW]	0.37	0.75	1.5	2.2
Typical shaft output [hp]	0.5	1.0	2.0	3.0
Enclosure size	MA01c	MA01c	MA02c	MA02a
Output current				
Continuous (3x200–240 V AC) [A]	2.2	4.2	6.8	9.6
Intermittent (3x200–240 V AC) [A]	3.3	6.3	10.2	14.4

Table 15: Mains Supply 1x200–240 V AC (continued)

Maximum cable size				
(Mains, motor) [mm ² /AWG]	4/10			
Maximum input current				
Continuous (1x200–240 V) [A]	6.1	11.6	18.7	26.4
Intermittent (1x200–240 V) [A]	8.3	15.6	26.4	37
EMC filter type	C1/C4			
Environment				
Power loss [W] ⁽¹⁾	16	31	46	61
Efficiency [%] ⁽¹⁾	97.5	97.6	97.6	97.9

1) The value is measured at 100% rated torque-producing current and 90% rated motor stator frequency according to IEC 61800-9-2 and EN 50598-2.

4.1.3 Mains Supply 3x200–240 V AC

Table 16: Mains Supply 3x200–240 V AC

Normal overload 150% for 1 minute								
Frequency converter	02A4	04A2	07A8	11A0	15A2	24A2	31A0	46A2
Typical shaft output [kW]	0.37	0.75	1.5	2.2	3.7	5.5	7.5	11
Typical shaft output [hp]	0.5	1.0	2.0	3.0	5.0	7.5	10	15
Enclosure size	MA01a	MA01a	MA02a	MA03a	MA03a	MA04a	MA04a	MA05a
Output current								
Continuous (3x200–240 V AC) [A]	2.4	4.2	7.8	11	15.2	24.2	31	46.2
Intermittent (3x200–240 V AC) [A]	3.6	6.3	11.7	16.5	22.8	36.3	46.5	69.3
Maximum cable size								
(Mains, motor) [mm ² /AWG]	4/10					16/6		
Maximum input current								
Continuous (3x200–240 V) [A]	3.8	6.7	12.5	17.7	24.3	33.0	42.0	42.0
Intermittent (3x200–240 V) [A]	5.7	8.3	18.8	26.6	35.3	49.5	63.0	63.0
EMC filter type	C4							
Environment								
Power loss [W] ⁽¹⁾	21	36	53	80	92	162	228	385
Efficiency [%] ⁽¹⁾	97.3	97.4	97.9	97.7	97.5	97.7	97.6	97.3

1) The value is measured at 100% rated torque-producing current and 90% rated motor stator frequency according to IEC 61800-9-2 and EN 50598-2.

4.1.4 Mains Supply 3x380–480 V AC

Table 17: Mains Supply 3x380–480 V AC, MA01a–MA02a

Normal overload 150% for 1 minute						
Frequency converter	01A2	02A2	03A7	05A3	07A2	09A0
Typical shaft output [kW]	0.37	0.75	1.5	2.2	3.0	4.0
Typical shaft output [hp]	0.5	1.0	2.0	3.0	4.0	5.5
Enclosure size	MA01a	MA01a	MA01a	MA02a	MA02a	MA02a
Output current						
Continuous (3x380–440 V) [A]	1.2	2.2	3.7	5.3	7.2	9.0
Intermittent (3x380–440 V) [A]	1.8	3.3	5.6	8.0	10.8	13.7
Continuous (3x440–480 V) [A]	1.1	2.1	3.4	4.8	6.3	8.2
Intermittent (3x440–480 V) [A]	1.7	3.2	5.1	7.2	9.5	12.3
Maximum cable size						
(Mains, motor) [mm ² /AWG]	4/10					
Maximum input current						
Continuous (3x380–440 V) [A]	1.9	3.5	5.9	8.5	11.5	14.4
Intermittent (3x380–440 V) [A]	2.6	4.7	8.7	12.6	16.8	20.2
Continuous (3x440–480 V) [A]	1.7	3.0	5.1	7.3	9.9	12.4
Intermittent (3x440–480 V) [A]	2.3	4.0	7.5	10.8	14.4	17.5
EMC filter type	C2/C4					
Environment						
Power loss [W] ⁽¹⁾	17	25	34	48	58	74
Efficiency [%] ⁽¹⁾	97.3	97.8	98.0	98.3	98.5	98.3

1) The value is measured at 100% rated torque-producing current and 90% rated motor stator frequency according to IEC 61800-9-2 and EN 50598-2.

Table 18: Mains Supply 3x380–480 V AC, MA03a–MA05a

Normal overload 150% for 1 minute						
Frequency converter	12A0	15A5	23A0	31A0	37A0	43A0
Typical shaft output [kW]	5.5	7.5	11	15	18.5	22
Typical shaft output [hp]	7.5	10	15	20	25	30
Enclosure size	MA03a	MA03a	MA04a	MA04a	MA05a	MA05a
Output current						
Continuous (3x380–440 V) [A]	12	15.5	23	31	37	43
Intermittent (3x380–440 V) [A]	18	23.5	34.5	46.5	55.5	64.5

Table 18: Mains Supply 3x380–480 V AC, MA03a–MA05a (continued)

Continuous (3x440–480 V) [A]	11	14	21	27	34	40
Intermittent (3x440–480 V) [A]	16.5	21.3	31.5	40.5	51	60
Maximum cable size						
(Mains, motor) [mm ² /AWG]	4/10		16/6			
Maximum input current						
Continuous (3x380–440 V) [A]	19.2	24.8	33	42	34.7	41.2
Intermittent (3x380–440 V) [A]	27.4	36.3	47.5	60	49	57.6
Continuous (3x440–480 V) [A]	16.6	21.4	29	36	31.5	37.5
Intermittent (3x440–480 V) [A]	23.6	30.1	41	52	44	53
EMC filter type	C2/C4					
Environment						
Power loss [W] ⁽¹⁾	104	127	213	285	358	466
Efficiency [%] ⁽¹⁾	98.3	98.4	98.2	98.3	98.2	98

1) The value is measured at 100% rated torque-producing current and 90% rated motor stator frequency according to IEC 61800-9-2 and EN 50598-2.

4.2 General Technical Data

4.2.1 Protection and Features

- Electronic motor thermal protection against overload.
- Temperature monitoring of the heat sink ensures that the drive trips if there is overtemperature.
- The drive is protected against short circuits between motor terminals U, V, W.
- When a motor phase is missing, the drive trips and issues a fault.
- When a mains phase is missing, the drive trips or issues a warning (depending on the load).
- Monitoring of the DC-link voltage ensures that the drive trips when the DC-link voltage is too low or too high.
- The drive is protected against ground faults on motor terminals U, V, W.

4.2.2 Grid Side

Table 19: Mains Supply

Function	Data
Supply voltage	1x100–120 V AC ±10%, -15% at reduced torque performance, depending on motor type.
	1x200–240 V AC ±10%, -15% at reduced torque performance, depending on motor type.
	3x380–480 V AC ±10%, -15% at reduced torque performance, depending on motor type.
Grid types	TN, TT, IT, Grounded Delta grids. For more information, see 7.3.1 Grid Types . For details on the parameters related to grid types, refer to the application guide.
Supply frequency	50/60 Hz ±5%
Maximum temporary imbalance between mains phases	3% of rated voltage, depending on grid impedance.

Table 19: Mains Supply (continued)

Function	Data
Displacement power factor	near unity (>0.98)
Switching on input supply from a discharged drive	MA01a–MA03a: Maximum 2 times/min
	MA04a–MA05a: Maximum 1 time/min
Environment	Overvoltage category III/pollution degree 2

4.2.3 Motor Output and Motor Data

Table 20: Motor Output (U, V, W)

Function	Data
Output voltage	0–100 % of supply voltage
Output frequency ⁽¹⁾	Induction motor <ul style="list-style-type: none"> • 0–200 Hz (VVC+ mode) • 0–500 Hz (U/f mode) PM motor <ul style="list-style-type: none"> • 0–400 Hz (VVC+ mode)
Frequency resolution	0.001 Hz
Switching on output	±0.003 Hz

1) Dependent on voltage, current, and control mode.

4.2.4 Torque Characteristics

Table 21: Torque Characteristics

Function	Data
Overload torque	150% for 60 s every 10 min
Overload torque at start	200% for 1 s
Torque rise time (VVC+)	50 ms

4.2.5 Control I/O

4.2.5.1 Control I/O Overview

This chapter covers the general specifications of the control I/O.

The standard configuration for iC2-Micro Frequency Converters is:

- 4 digital inputs.
- 1 digital I/O (Select ether digital input or output).
- 2 analog inputs (voltage or current).
- 1 analog output (current).
- 1 relay outputs (NC/NO).
- 24 V and 10 V reference for digital and analog I/O.

All control inputs and outputs are PELV galvanic isolated from supply voltage and other high-voltage terminals, unless otherwise specified.

4.2.5.2 Digital and Pulse Input

Control inputs and outputs are PELV galvanically isolated from supply voltage and other high-voltage terminals, unless otherwise specified.

Table 22: Digital and Pulse Input

Function		Data
Terminal number		T13, T14, T15 ⁽¹⁾ , T17, and T18 ⁽²⁾ .
Digital input	Logic	Selectable PNP or NPN
	Voltage levels	0/24 V
	PNP	<ul style="list-style-type: none"> • 0: <5 V DC • 1: >11 V DC
	NPN	<ul style="list-style-type: none"> • 0: >19 V DC • 1: < 13 V DC
	Maximum allowed voltage	28 V DC
	Input resistance	Approximately 4 kΩ
Thermistor input	PTC ⁽³⁾	According to DIN 44081/DIN 44082
Pulse input	Pulse frequency range	1 Hz–32 kHz
	Minimum duty cycle	40%
	Accuracy	1% of full scale

1) T15 is selectable for either digital input, digital output, or pulse output. The default setting is digital input.

2) T18 can also be used for pulse input.

3) External insulation of the sensor is required to comply with PELV.

4.2.5.3 Digital and Pulse Output

Control inputs and outputs are PELV galvanically isolated from supply voltage and other high-voltage terminals, unless otherwise specified.

Table 23: Digital and Pulse Output

Function		Data
Terminal number		T15 ⁽¹⁾
Digital output (24 V)	Voltage level	0/24 V
	Maximum output load (sink/source)	40 mA
	Frequency range - Pulse output	4 Hz–32 kHz
	Maximum load	1 kΩ
	Maximum capacitive load at maximum frequency	10 nF
	Pulse output accuracy	0.1% of full scale
	Resolution of pulse output	10 bit

1) T15 is selectable for either digital input, digital output, or pulse output. The default setting is digital input.

4.2.5.4 Analog Input

Control inputs and outputs are PELV galvanically isolated from supply voltage and other high-voltage terminals, unless otherwise specified.

Table 24: Analog Input

Function	Data
Terminal number	T33 and T34
Input mode	Current or Voltage ⁽¹⁾
Voltage mode	<ul style="list-style-type: none"> Voltage range: 0–10 V (scalable) Input impedance: 10 kΩ Maximum voltage: +20 V/-12 V
Current mode	<ul style="list-style-type: none"> Current range: 0/4-20 mA (scalable) Input impedance: 200 Ω Maximum current: 30 mA
Resolution	0.1% of full scale
Accuracy	1% of full scale
Bandwidth	100 Hz

1) The selection is made in the software. For more information, refer to the application guide.

4.2.5.5 Analog Output

Control inputs and outputs are PELV galvanically isolated from supply voltage and other high-voltage terminals, unless otherwise specified.

Table 25: Analog Output

Function	Data
Terminal number	T31
Output range: Current	0/4–20 mA
Maximum load resistor to GND	500 Ω
Resolution	0.1% of full scale
Accuracy	1% of full scale

4.2.5.6 Relay Output

Relays provide PELV isolation to supply voltage, other high-voltage terminals and low-voltage control.

Table 26: Relay Output

Function	Data
Terminal number	01, 02, and 03
Relay configuration	SPDT (NO/NC)
Maximum terminal load (AC-1): Resistive load	250 V AC, 2 A
Maximum terminal load (AC-15): Inductive load @ $\cos\phi=0.4$	250 V AC, 0.2 A
Maximum terminal load (DC-1): Resistive load	30 V DC, 2 A
Maximum terminal load (DC-13): Inductive load	24 V DC, 0.1 A
Minimum load	<ul style="list-style-type: none"> • 24 V DC, 10 mA • 24 V AC, 20 mA

4.2.5.7 Auxiliary Voltages

Auxiliary voltage outputs are used as reference for analog and digital inputs.

Table 27: Auxiliary Voltages

Function	Data	
10 V output	Output voltage	+10.5 V \pm 0.5 V
	Maximum load	25 mA
24 V output	Output voltage	+24 V \pm 20%
	Maximum load	100 mA

4.2.6 RS485 Serial Communication

Table 28: RS485 Serial Communication

Function	Data
Terminal number	68 (P, TX+, RX+), 69 (N, TX-, RX-)
Terminal number	61 common for terminals 68 and 69

For more details on RS485 communication and configuration, refer to the *iC2-Micro Frequency Converters Application Guide*.

4.2.7 Ambient Conditions

4.2.7.1 Overview of Ambient Conditions

iC2-Micro Frequency Converters are designed for installation and use in weather-protected environments. The available protection ratings are:

- IP20/Open Type.
- IP21/UL Type 1 (IP21/Type 1 conversion kit as option).

The environments used as reference for the design criteria are described in the standards IEC 60721-3-1:2019, IEC 60721-3-2:2018 and, IEC 60721-3-3:2019, unless otherwise specified.

Conditions are given for:

- Storage (See [4.2.7.2 Ambient Conditions during Storage](#))
- Transport (See [4.2.7.3 Ambient Conditions during Transport](#))
- Operation (See [4.2.7.4 Ambient Conditions during Operation](#))

4.2.7.2 Ambient Conditions during Storage

Table 29: Ambient Conditions during Storage

Function	Data
Ambient temperature	-25 °...+65 °C (-13 °...+149 °F)
Climatic condition	1K21, maximum 95% non-condensing
Chemically active substances	1C2
Solid particles (non-conductive particles/dust only)	1S11
Vibration	1M11
Shock	1M11
Biological ambient	1B1

4.2.7.3 Ambient Conditions during Transport

Table 30: Ambient Conditions during Transport

Function	Data
Ambient temperature	-25 °...+70 °C (-13 °...+158 °F)
Climatic condition	2K11, maximum 95% non-condensing
Chemically active substances	2C2
Solid particles (non-conductive particles or dust only)	2S5
Vibration	2M5
Shock	2M4
Biological ambient	2B1

4.2.7.4 Ambient Conditions during Operation

Table 31: Ambient Conditions during Operation

Function	Data
Ambient temperature	-20 °C to 55 °C (-4 °F to 131 °F), and -10 °C to 50 °C (14 °F to 131 °F) without derating
Climatic condition	3K22, maximum 95% non-condensing ⁽¹⁾
Chemically active substances	C4
Solid particles (non-conductive particles/dust)	3S6
Vibration	3M11
Shock	3M11
Biological ambient	3B1
Maximum altitude above sea level	Without derating: 1000 m (3280 ft) With derating: 1000 m (3280 ft) to 4000 m (13123 ft), derate the output current by 1% for each 100 m (328 ft). Regarding IEC 61800-5-1 compliance, the default maximum altitude is 2000 m (6562 ft). When the installation site is at an altitude of 2000 m (6562 ft) to 4000 m (13123 ft), contact Danfoss for further information.

¹⁾ Ensure maximum rate of change of temperature 0.1 °C/min (0.18 °F/min) to avoid condensation.

4.3 Fuses and Circuit Breakers

For proper protection of the installation cable and the drive, fuses and/or circuit breakers must be used. If short circuit occurs, fuses and circuit breakers protect the power cable and limit the damage to the drive and components connected to the drive.

When using circuit breakers, be aware of the limitation to the short-circuit capacity of the supply, and follow the installation instructions from the manufacturer. The short-circuit rating must comply with the values given in [Table 32](#).

The recommendations for fuses and circuit breakers must be followed to comply with relevant regulations. If recommendations are not followed, and problems occur, warranty may be affected. For more details, contact Danfoss.

Table 32: Fuses and Circuit Breakers

iC2-Micro	Non cabinet					Cabinet			
	UL fuses				CE fuses	UL circuit breaker	CE circuit breaker	Test cabinet size [Height x Width x Depth] [mm (in)]	Minimum cabinet volume [L]
kW (hp)	RK1	T	J	CC	gG	ABB MS165 Maximum trip level	Eaton Maximum trip level		
Standard fault current SCCR	5 kA	5 kA			5 kA	5 kA	5 kA		
High fault current SCCR	–	100 kA			–	65 kA ⁽¹⁾	–		
1x100-120 V AC									
0.37 (0.5)	25 A				25 A	25 A	PKZM4-25	500 x 400 x 260 (19.7 x 15.7 x 10.2)	52
1.1 (1.5)	35 A				50 A	42 A	PKZM4-50		
1x200-240 V AC									
0.37–0.75 (0.5–1.0)	25 A				25 A	25 A	PKZM4-25	500 x 400 x 260 (19.7 x 15.7 x 10.2)	52
1.5 (2.0)	35 A				35 A	32 A	PKZM4-32		
2.2 (3.0)	40 A				50 A	42 A	PKZM4-50		
3x200-240 V AC									
0.37–0.75 (0.5–1.0)	15 A				16 A	16 A	PKZM0-16	500 x 400 x 260 (19.7 x 15.7 x 10.2)	52
1.5 (2.0)	30 A				32 A	32 A	PKZM4-32		
2.2–3.7 (3.0–5.0)	40 A				40 A	42 A	PKZM4-40		
5.5–7.5 (7.5–10)	60 A				63 A	65 A	PKZM4-63	800 x 400 x 300 (31.5 x 15.7 x 11.8)	96
11 (15)	60 A				80 A	80 A	NZMN1-A80		
3x380-480 V									
0.37–1.5 (0.5–2.0)	15 A				16 A	16 A	PKZM0-16	500 x 400 x 260 (19.7 x 15.7 x 10.2)	52
2.2–4.0 (3.0–5.5)	30 A				40 A	32 A	PKZM4-32		
5.5–7.5 (7.5–10)	40 A				40 A	42 A	PKZM4-40		
11–15 (15–20)	60 A				63 A	65 A	PKZM4-63	800 x 400 x 300 (31.5 x 15.7 x 11.8)	96
18.5–22 (25–30)	60 A				80 A	80 A	NZMN1-A80		

1) The power ratings of iC2-Micro Frequency Converters up to 15 kW (20 hp) are 65 kA when protected by Type E CMC, 18.5 kW (25 hp) and 22 kW (30 hp) are 50 kA when protected by Type E CMC.

4.4 Power Connectors

To ensure proper operation, observe the cross-section dimensions, stripping length, and tightening torques.

The dimensions apply to both solid and stranded cables. Drives are designed for use of 70 °C (158 °F) rated copper cables. If nothing else is stated, the ambient temperature of the drive matches the cable rating. Aluminum cables can be used from 35 mm² onwards. Proper connections must be secured by removing the oxide layer and applying joint compound.

NOTICE

Using a cable with the maximum allowed cross-section requires more effort during the installation.

Table 33: Power Cable Sizing

Enclosure size	Terminal	Cross-section [mm ² (AWG)]	Torque [Nm (lb-in)]	Stripping length [mm (in)]	Connector type	Screw/lug type
MA01c	Mains, motor, and DC connection	0.5–4.0 (24–10)	0.7 (6.2)	7–9 (0.28–0.35)	Terminal block	Slot
	Customer relay	0.5–2.5 (24–12)	0.5 (4.4)	6–7 (0.24–0.28)	Terminal block	Slot
MA02c	Mains, motor, and DC connection	0.5–4.0 (24–10)	0.7 (6.2)	7–9 (0.28–0.35)	Terminal block	Slot
	Customer relay	0.5–2.5 (24–12)	0.5 (4.4)	6–7 (0.24–0.28)	Terminal block	Slot
MA01a	Mains and motor	0.5–4.0 (24–10)	0.7 (6.2)	7–9 (0.28–0.35)	Terminal block	Slot
	DC connection	2.1–5.3 (14–10)	–	6–7 (0.24–0.28)	Straight receptacles	–
	Customer relay	0.5–2.5 (24–12)	0.5 (4.4)	6–7 (0.24–0.28)	Terminal block	Slot
MA02a	Mains and motor	0.5–4.0 (24–10)	0.7 (6.2)	7–9 (0.28–0.35)	Terminal block	Slot
	Brake ⁽¹⁾ and DC connection	2.1–5.3 (14–10)	–	6–7 (0.24–0.28)	Straight receptacles	–
	Customer relay	0.5–2.5 (24–12)	0.5 (4.4)	6–7 (0.24–0.28)	Terminal block	Slot
MA03a	Mains and motor	0.5–4.0 (24–10)	0.7 (6.2)	7–9 (0.28–0.35)	Terminal block	Slot
	Brake and DC connection	2.1–5.3 (14–10)	–	6–7 (0.24–0.28)	Straight receptacles	–
	Customer relay	0.5–2.5 (24–12)	0.5 (4.4)	6–7 (0.24–0.28)	Terminal block	Slot
MA04a	Mains	0.5–16 (22–6)	1.2 (10.6)	12–13 (0.47–0.51)	Terminal block	Slot
	Motor, brake, and DC connection	0.5–16 (20–6)	1.2 (10.6)	12–15 (0.47–0.59)	Terminal block	Slot
	Customer relay	0.5–2.5 (24–12)	0.5 (4.4)	6–7 (0.24–0.28)	Terminal block	Slot
MA05a	Mains	0.5–16 (22–6)	1.2 (10.6)	12–13 (0.47–0.51)	Terminal block	Slot
	Motor, brake, and DC connection	0.5–16 (20–6)	1.2 (10.6)	12–15 (0.47–0.59)	Terminal block	Slot
	Customer relay	0.5–2.5 (24–12)	0.5 (4.4)	6–7 (0.24–0.28)	Terminal block	Slot

1) For MA02a, only 3x200–240 V and 3x380–480 V drives have brake function.

4.5 Acoustic Noise

The acoustic noise from the drive comes from 3 sources:

- DC-link coils.
- Integral fan.
- RFI filter choke.

The typical values measured at a distance of 1 m (3.3 ft) from the unit:

Table 34: Typical Measured Values

Enclosure size	Full fan speed [dBA]
MA01c	–
MA02c	45.9
MA01a	39.8
MA02a	54.1
MA03a	59.5
MA04a	63.8
MA05a	68.7

Test results performed according to ISO 3744 for audible noise magnitude in a controlled environment. Noise tone has been quantified for engineering data record of hardware performance per ISO 1996-2 Annex D.

4.6 EMC Compliance Levels

4.6.1 Overview of EMC Compliance Levels

The drives are designed and tested to comply with relevant EMC standards. The performance level depends on the actual drive and selected EMC compliance level.

The EMC compliance levels are tested under the following conditions:

- The drive (with options if relevant).
- Shielded control and communication cables.
- External control with digital I/O and analog control.
- Single motor connected with shielded cable for emission test and unshielded cable for immunity test.
- Load share and brake cables.
- Standard drive settings.

NOTICE

According to the EMC Directive, a system is defined as a combination of several types of equipment, finished products, and/or components combined, designed, and/or put together by the same person (system manufacturer) intended to be placed on the market for distribution as a single functional unit for an end user and intended to be installed and operated together to perform a specific task.

The EMC directive applies to products/systems and installations, but in case the installation is built up of CE-marked products/systems, the installation can also be considered compliant with the EMC directive. Installations are not CE-marked.

According to the EMC Directive, Danfoss as a manufacturer of products/systems is responsible for obtaining the essential requirements of the EMC directive and attaching the CE mark. For systems involving load sharing and other DC terminals, Danfoss can only ensure compliance with EMC Directive when combinations of Danfoss products are connected as described in the technical documentation.

If installed in residential environments, and not compliant to class C1, the drive may not provide adequate protection to radio reception in such locations.

- In such cases, supplementary mitigation measures might be required, for example, the use of shielding or increasing the distance between affected products.

4.6.2 Emission Requirements

According to the EMC product standard for AC drives, EN/IEC 61800-3, the EMC requirements depend on the intended use of the drive. Four categories are defined in the EMC product standard. The definitions of the 4 categories together with the requirements for mains supply voltage conducted emissions are given in [Table 35](#).

Table 35: Emission Requirements

Compliance class	Intended use of the drive
C1	Drives installed in the 1st environment (home and office) with a supply voltage less than 1000 V.
C2	Drives installed in the 1st environment (home and office) with a supply voltage less than 1000 V, which are neither plug-in nor movable and are intended for installation and commissioning by a professional.
C3	Drives installed in the 2nd environment (industrial) with a supply voltage lower than 1000 V.
C4	Drives installed in the 2nd environment (industrial) with a supply voltage equal to or above 1000 V or rated current equal to or above 400 A or intended for use in complex systems.

The drives are designed to comply to 1 of the following 4 categories, defined in the EMC product standard, EN/IEC 61800-3.

NOTICE

When the drive is connected to the public supply network, without the external reactors installed, the drive may not comply with harmonic emission requirements of IEC/EN 61000-3-2 and IEC/EN 61000-3-12.

4.6.3 EMC Immunity Requirements

The immunity requirements for drives depend on the environment in which they are installed. The requirements for the industrial environment are higher than the requirements for the home and office environment. All Danfoss drives comply with the requirements for the industrial environment. Therefore, they also comply with the lower requirements for home and office environment with a large safety margin.

To document immunity against burst transient from electrical phenomena, the following immunity tests have been made on a system consisting of:

- A drive (with options if relevant).
- A shielded control cable.
- A control box with potentiometer, motor cable, and motor.

The tests were performed in accordance with the following basic standards:

- **EN 61000-4-2 (IEC 61000-4-2) Electrostatic discharges (ESD):** Simulation of electrostatic discharges from human beings.
- **EN 61000-4-3 (IEC 61000-4-3) Radiated immunity:** Amplitude modulated simulation of the effects of radar and radio communication equipment and mobile communications equipment.
- **EN 61000-4-4 (IEC 61000-4-4) Burst transients:** Simulation of interference caused by switching a contactor, relay, or similar devices.
- **EN 61000-4-5 (IEC 61000-4-5) Electromagnetic compatibility (EMC) - Part 4-5: Testing and measurement techniques - Surge immunity test:** Simulation of transients caused by, for example, lightning that strikes near installations.
- **EN 61000-4-6 (IEC 61000-4-6) Conducted immunity:** Simulation of the effect from radio-transmission equipment joined by connection cables.

The immunity requirements should follow product standard IEC 61800-3. See [Table 36](#) for details.

Table 36: EMC Immunity

Product standard	61800-3				
	ESD	Radiated immunity	Burst	Surge	Conducted immunity
Acceptance criterion	B	A	B	B	A
Mains cable	–	–	2 kV CN	1 kV/2 Ω DM 2 kV/12 Ω CM	10 V _{RMS}
Motor cable	–	–	2 kV CCC	–	10 V _{RMS}
Brake cable	–	–	2 kV CCC	–	10 V _{RMS}
Load sharing cable	–	–	2 kV CCC	–	10 V _{RMS}
Relay cable	–	–	2 kV CCC	–	10 V _{RMS}
Control cable	–	–	Length >2 m (6.6 ft) 1 kV CCC	Unshielded: 1 kV/42 Ω CM	10 V _{RMS}
Standard/fieldbus cable	–	–	Length >2 m (6.6 ft) 1 kV CCC	Unshielded: 1 kV/42 Ω CM	10 V _{RMS}
Control panel cable	–	–	Length >2 m (6.6 ft) 1 kV CCC	–	10 V _{RMS}
Enclosure	4 kV CD 8 kV AD	10 V/m	–	–	–
Definitions					
CD: Contact discharge AD: Air discharge		DM: Differential mode CM: Common mode		CN: Direct injection through coupling network CCC: Injection through capacitive coupling clamp	

4.7 EMC Compatibility and Motor Cable Length

- Drive with built-in EMC filter fulfills radiated emission C2 limits.
- Drive with non built-in EMC filter fulfills conducted/radiated emission C4 requirements.
- The drive is designed to operate with optimum performance within the maximum motor cable lengths defined in [Table 38](#).

Table 37: EMC Compatibility Motor Cable Length

Drive with built-in EMC filter	Maximum motor cable length (shielded), @4kHz	
	C1 (Conducted)	C2 (Conducted)
1x200–240 V	5 m (16.4 ft)	–
3x400–480 V	–	15 m (49.2 ft)

Table 38: Maximum Motor Cable Length

Maximum motor cable length (shielded)	Maximum motor cable length (unshielded)
50 m (164 ft)	75 m (246 ft)

4.8 dU/dt Conditions

When a transistor in the drive bridge switches, the voltage across the motor increases by a dU/dt ratio depending on the following factors:

- The motor cable type.
- The cross-section of the motor cable.
- The length of the motor cable.
- Whether the motor cable is shielded or not.
- Inductance.

The natural induction causes an overshoot U_{PEAK} in the motor voltage before it stabilizes itself at a level depending on the voltage in the DC link. The rise time and the peak voltage U_{PEAK} affect the service life of the motor.

If the peak voltage is too high, motors without phase coil insulation are affected. The longer the motor cable, the higher the rise time and peak voltage.

Switching of the IGBTs causes peak voltage on the motor terminals. The iC2-Micro Frequency Converters comply with IEC 60034-25 regarding motors designed to be controlled by drives. The iC2-Micro Frequency Converters also comply with IEC 60034-17 regarding Norm motors controlled by drives.

The following dU/dt data are measured at the motor terminal side with IEC 50% torque:

Table 39: dU/dt Data for iC2-Micro Frequency Converters

Enclosure size	Power [kW (hp)]	Cable length [m (ft)]	Mains voltage [V]	Rise time [μ sec]	U_{PEAK} [kV]	dU/dt [kV/ μ sec]
MA01c	0.37 (0.5)	5 (16.4)	1x120	0.067	0.438	5.21
MA01c	0.37 (0.5)	50 (164)	1x120	0.286	0.618	1.73
MA01c	0.75 (1.0)	5 (16.4)	1x240	0.067	0.438	5.21
MA01c	0.75 (1.0)	50 (164)	1x240	0.286	0.618	1.73

Table 39: dU/dt Data for iC2-Micro Frequency Converters (continued)

Enclosure size	Power [kW (hp)]	Cable length [m (ft)]	Mains voltage [V]	Rise time [μsec]	U_{PEAK} [kV]	dU/dt [kV/ μsec]
MA02c	1.1 (1.5)	5 (16.4)	1x120	0.132	0.464	2.82
MA02c	1.1 (1.5)	50 (164)	1x120	0.31	0.622	1.62
MA02c	1.5 (2.0)	5 (16.4)	1x240	0.132	0.464	2.82
MA02c	1.5 (2.0)	50 (164)	1x240	0.31	0.622	1.62
MA01a	0.75 (1.0)	5 (16.4)	3x240	0.092	0.458	3.96
MA01a	0.75 (1.0)	50 (164)	3x240	0.296	0.616	1.66
MA01a	1.5 (2.0)	5 (16.4)	3x400	0.132	0.732	4.46
MA01a	1.5 (2.0)	50 (164)	3x400	0.389	1.056	2.18
MA01a	1.5 (2.0)	5 (16.4)	3x480	0.143	0.848	4.76
MA01a	1.5 (2.0)	50 (164)	3x480	0.417	1.232	2.36
MA02a	1.5 (2.0)	5 (16.4)	3x240	0.09	0.52	4.69
MA02a	1.5 (2.0)	50 (164)	3x240	0.23	0.56	1.95
MA02a	2.2 (3.0)	5 (16.4)	1x240	0.078	0.562	5.71
MA02a	2.2 (3.0)	50 (164)	1x240	0.214	0.614	2.29
MA02a	4.0 (5.5)	5 (16.4)	3x400	0.136	0.752	4.47
MA02a	4.0 (5.5)	50 (164)	3x400	0.254	1.048	3.30
MA02a	4.0 (5.5)	5 (16.4)	3x480	0.149	0.896	4.85
MA02a	4.0 (5.5)	50 (164)	3x480	0.305	1.232	3.23
MA03a	3.7 (5.0)	5 (16.4)	3x240	0.078	0.529	5.46
MA03a	3.7 (5.0)	50 (164)	3x240	0.228	0.636	2.23
MA03a	7.5 (10)	5 (16.4)	3x400	0.098	0.804	6.08
MA03a	7.5 (10)	50 (164)	3x400	0.288	1.02	2.83
MA03a	7.5 (10)	5 (16.4)	3x480	0.112	0.926	6.02
MA03a	7.5 (10)	50 (164)	3x480	0.304	1.22	3.23
MA04a	7.5 (10)	5 (16.4)	3x240	0.116	0.5	3.47
MA04a	7.5 (10)	50 (164)	3x240	0.288	0.574	1.60
MA04a	15 (20)	5 (16.4)	3x400	0.144	0.71	3.96
MA04a	15 (20)	50 (164)	3x400	0.28	1.0	2.88
MA04a	15 (20)	5 (16.4)	3x480	0.172	0.794	3.71
MA04a	15 (20)	50 (164)	3x480	0.298	1.19	3.20
MA05a	11 (15)	5 (16.4)	3x240	0.078	0.407	4.14
MA05a	11 (15)	50 (164)	3x240	0.492	0.59	0.96

Table 39: dU/dt Data for iC2-Micro Frequency Converters (continued)

Enclosure size	Power [kW (hp)]	Cable length [m (ft)]	Mains voltage [V]	Rise time [μsec]	U_{PEAK} [kV]	dU/dt [kV/ μsec]
MA05a	22 (30)	5 (16.4)	3x400	0.108	0.66	4.89
MA05a	22 (30)	50 (164)	3x400	0.404	1.02	2.02
MA05a	22 (30)	5 (16.4)	3x480	0.148	0.78	4.26
MA05a	22 (30)	50 (164)	3x480	0.404	1.19	2.36

4.9 Derating

4.9.1 Overview of Derating

Consider derating if the drive is challenged under some special conditions. Derating of the drive includes:

- Manual derating.
- Automatic derating.

4.9.2 Manual Derating

Manual derating must be considered for:

- Air pressure – for installation at altitudes above 1000 m (3281 ft).
- Motor speed – at continuous operation at low RPM in constant torque applications.
- Ambient temperature – above 40 °C (104 °F), for details, see the following figures.

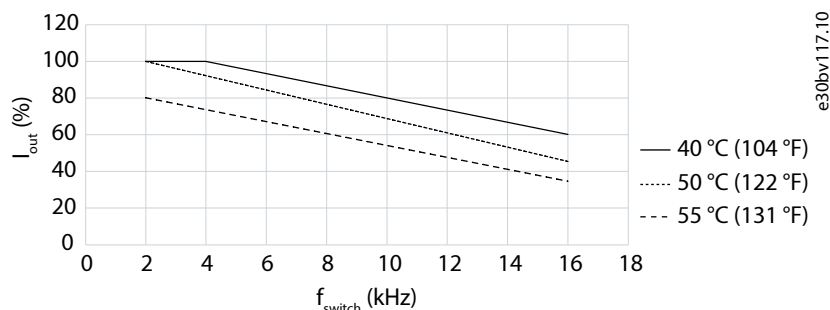

Figure 14: Derating of Output Current Versus Switching Frequency (MA01c 1x100–120 V AC and 1x200–240 V AC)

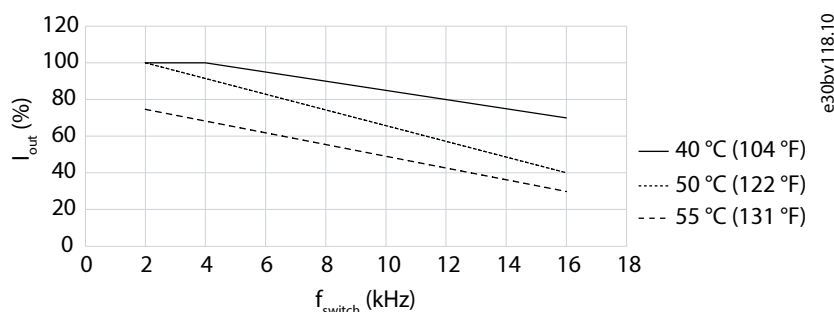

Figure 15: Derating of Output Current Versus Switching Frequency (MA02c 1x100–120 V AC and 1x200–240 V AC)

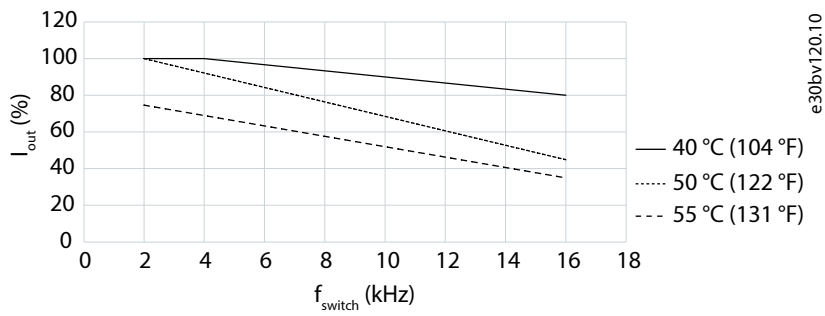

Figure 16: Derating of Output Current Versus Switching Frequency (MA02a 1x200–240 V AC)

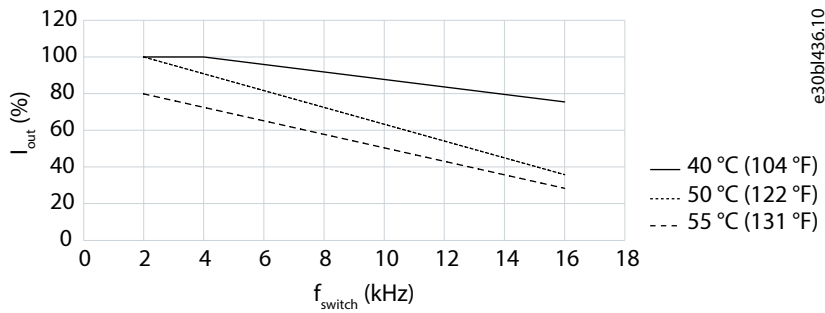

Figure 17: Derating of Output Current Versus Switching Frequency (MA01a 3x200–240 V AC)

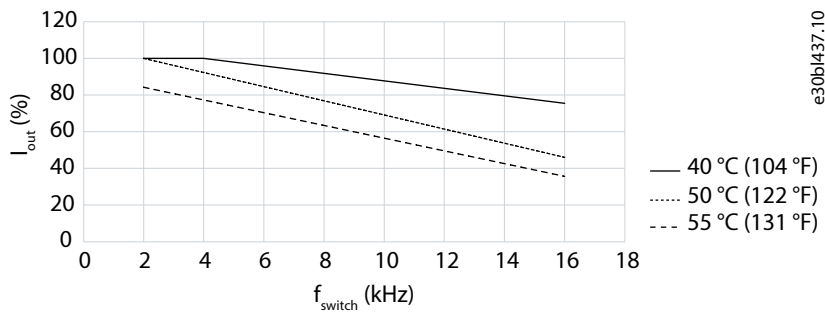

Figure 18: Derating of Output Current Versus Switching Frequency (MA02a 3x200–240 V AC)

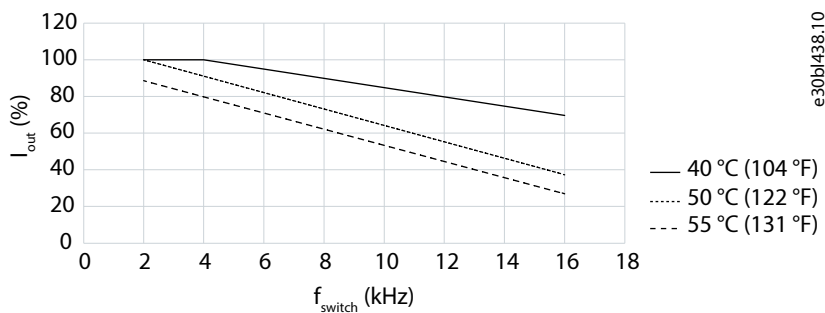

Figure 19: Derating of Output Current Versus Switching Frequency (MA03a 3x200–240 V AC)

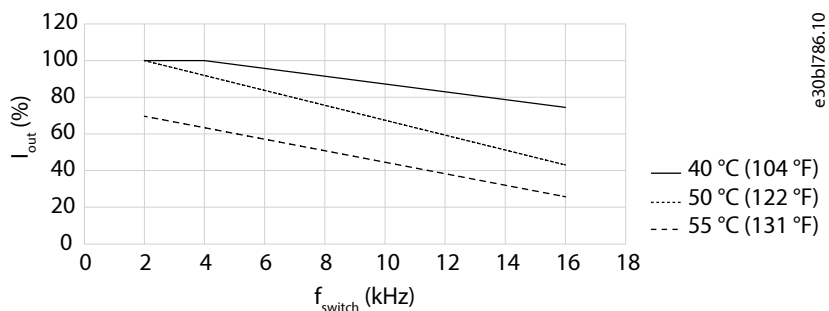

Figure 20: Derating of Output Current Versus Switching Frequency (MA04a 3x200-240 V AC)

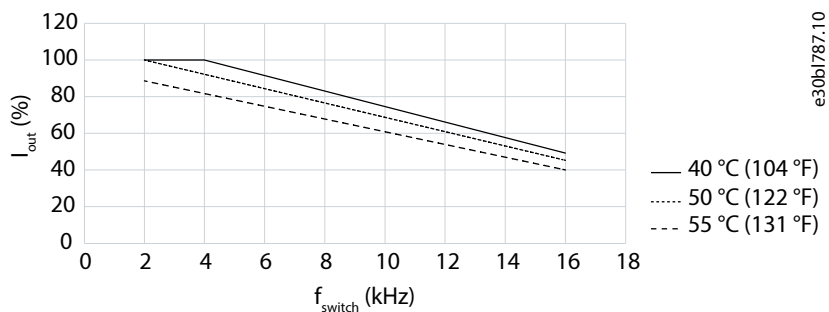

Figure 21: Derating of Output Current Versus Switching Frequency (MA05a 3x200-240 V AC)

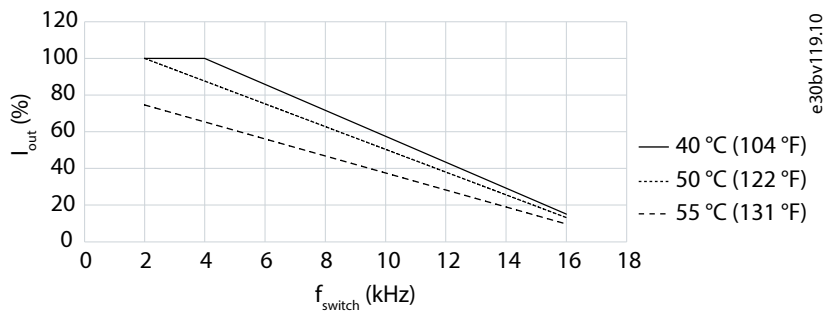

Figure 22: Derating of Output Current Versus Switching Frequency (MA01a 3x380-480 V AC)

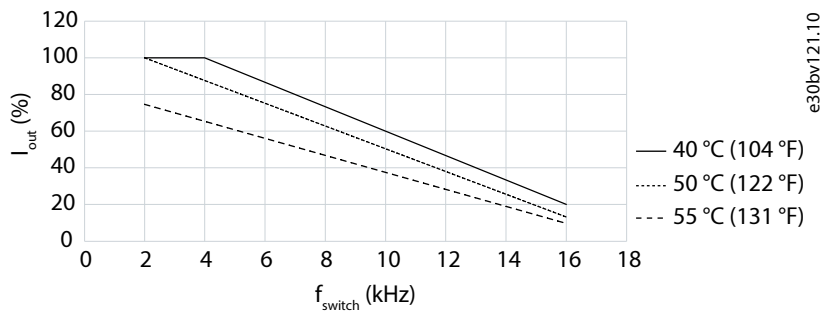

Figure 23: Derating of Output Current Versus Switching Frequency (MA02a 3x380-480 V AC)

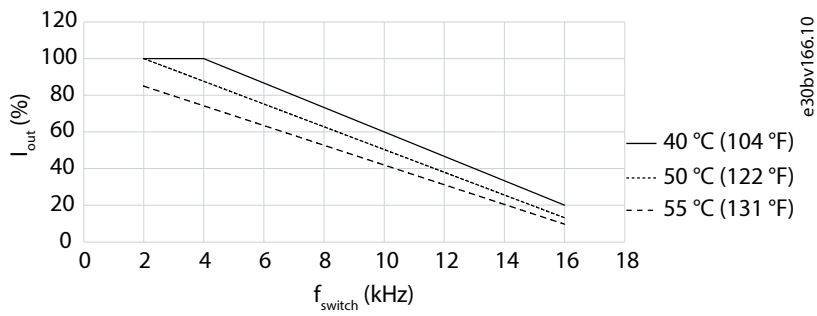

Figure 24: Derating of Output Current Versus Switching Frequency (MA03a 3x380–480 V AC)

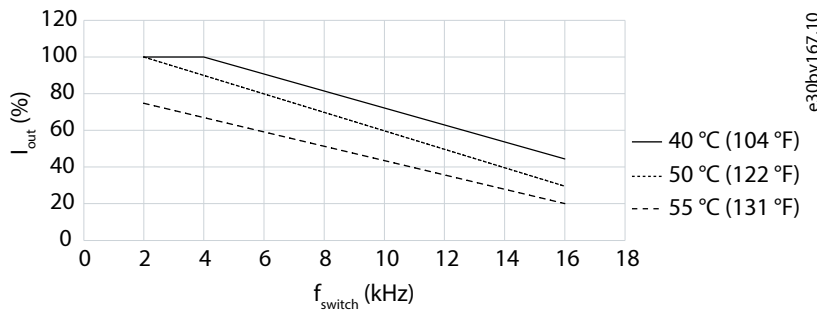

Figure 25: Derating of Output Current Versus Switching Frequency (MA04a 3x380–480 V AC)

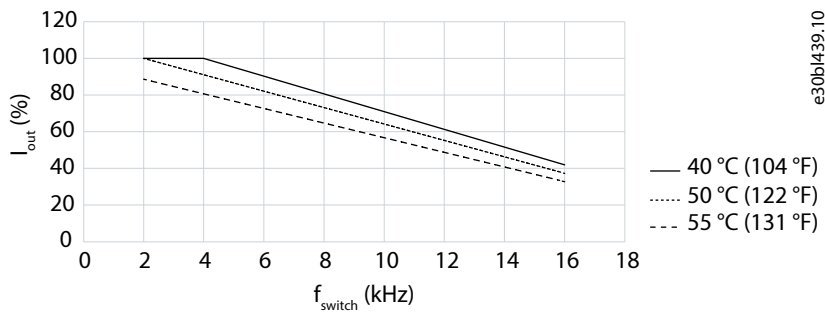

Figure 26: Derating of Output Current Versus Switching Frequency (MA05a 3x380–480 V AC)

4.9.3 Automatic Derating

To ensure the performance at critical stages, the drive checks for the following critical levels constantly and adjusts the switching frequency automatically.

- Critical high temperature on the heat sink.
- High motor load.
- Low motor speed.
- Protection signals (overvoltage/undervoltage, overcurrent, ground fault, and short circuit) are triggered.

5 Exterior Dimensions

5.1 IP20/Open Type Enclosure Sizes and Dimensions

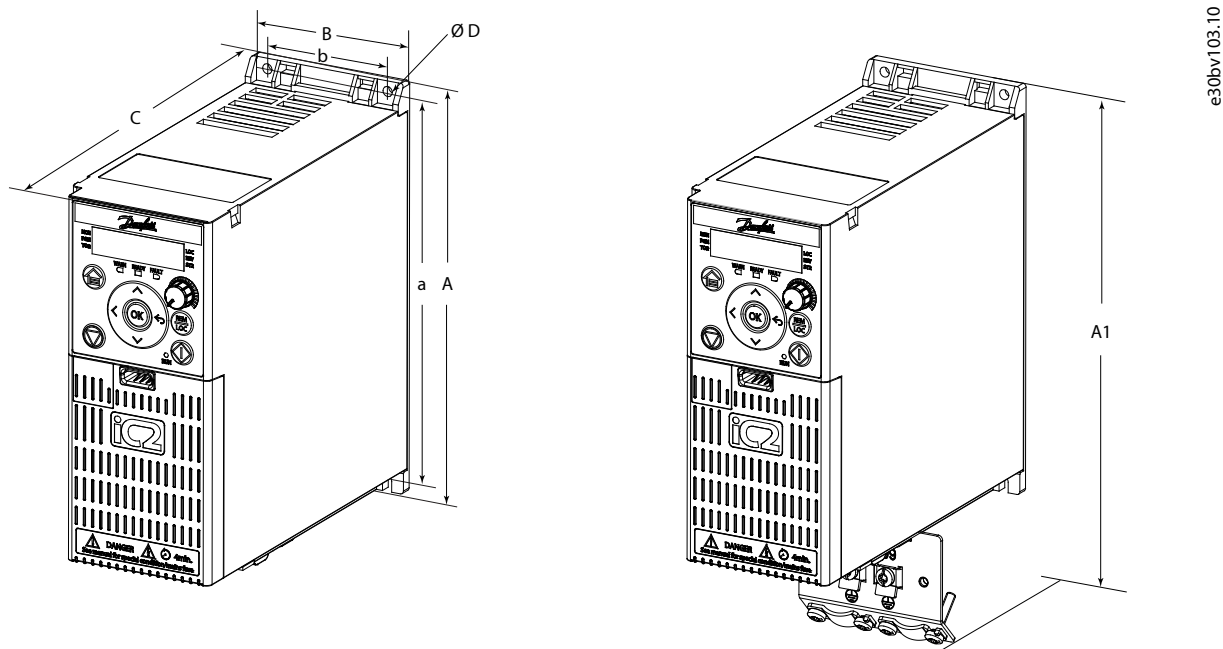

Figure 27: IP20/Open Type Enclosure Sizes and Dimensions

Table 40: IP20/Open Type Enclosure Sizes and Dimensions

Enclosure	Height [mm (in)]			Width [mm (in)]		Depth [mm (in)] ⁽¹⁾	Mounting holes [mm (in)]	Maximum weight [kg (lb)] ⁽²⁾
	A	A1 ⁽³⁾	a	B	b			
MA01c	150 (5.9)	216 (8.5)	140.4 (5.5)	70 (2.8)	55 (2.2)	143 (5.6)	4.5 (0.18)	1.0 (2.4)
MA02c	176 (6.9)	232.2 (9.1)	150.5 (5.9)	75 (3.0)	59 (2.3)	157 (6.2)	4.5 (0.18)	1.3 (2.9)
MA01a	150 (5.9)	202.5 (8.0)	140.4 (5.5)	70 (2.8)	55 (2.2)	158 (6.2)	4.5 (0.18)	1.1 (2.4)
MA02a	186 (7.3)	240 (9.4)	176.4 (6.9)	75 (3.0)	59 (2.3)	175 (6.9)	4.5 (0.18)	1.6 (3.5)
MA03a	238.5 (9.4)	291 (11.5)	226 (8.9)	90 (3.5)	69 (2.7)	200 (7.9)	5.5 (0.22)	3.0 (6.6)
MA04a	292 (11.5)	365.5 (14.4)	272.4 (10.7)	125 (4.9)	97 (3.8)	244.5 (9.6)	7.0 (0.28)	6.0 (13.2)
MA05a	335 (13.2)	396.5 (15.6)	315 (12.4)	165 (6.5)	140 (5.5)	248 (9.8)	7.0 (0.28)	9.5 (20.9)

1) The potentiometer on the local control panel extends 6.5 mm (0.26 in) from the drive.

2) Not including decoupling plate.

3) Including decoupling plate.

5.2 IP21/UL Type 1 Enclosure Sizes and Dimensions

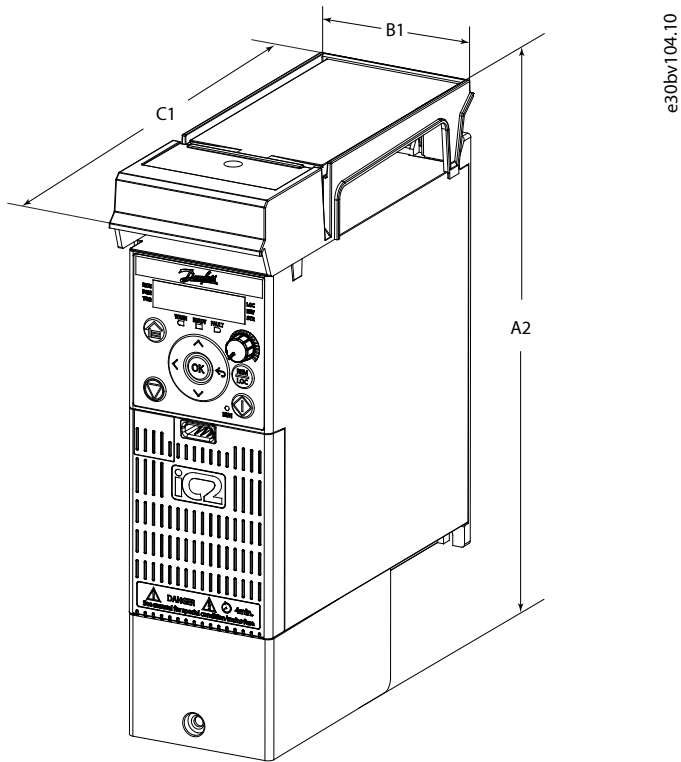

Figure 28: IP21/UL Type 1 Enclosure Sizes and Dimensions

Table 41: IP21/UL Type 1 Enclosure Sizes and Dimensions

Enclosure	Height [mm (in)]	Top cover width [mm (in)]	Depth [mm (in)]
	A2	B1	C1
MA01c	242.2 (9.5)	81.5 (3.2)	153.5 (6.0)
MA02c	257 (10.1)	92.4 (3.6)	165 (6.5)
MA01a	220.2 (8.7)	73.2 (2.9)	166.5 (6.6)
MA02a	255 (10.0)	78 (3.0)	184 (7.2)
MA03a	298 (11.7)	98 (3.9)	210 (8.3)

5.3 NEMA 1 Enclosure Sizes and Dimensions

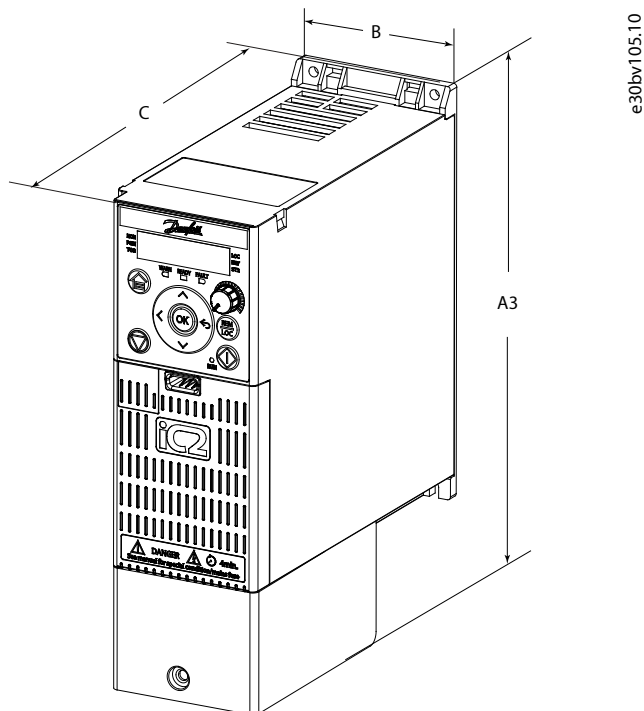

Figure 29: NEMA 1 Enclosure Sizes and Dimensions

Table 42: NEMA 1 Enclosure Sizes and Dimensions

Enclosure	Height [mm (in)]	Width [mm (in)]	Depth [mm (in)]
	A3	B	C
MA01c	206.2 (8.1)	70 (2.8)	143 (5.6)
MA02c	221 (8.7)	75 (3.0)	157 (6.2)
MA01a	195 (7.7)	70 (2.8)	158 (6.2)
MA02a	231 (9.1)	75 (3.0)	175 (6.9)
MA03a	283 (11.1)	90 (3.5)	200 (7.9)
MA04a	352.5 (13.9)	125 (4.9)	244.5 (9.6)
MA05a	392 (15.4)	165 (6.5)	248 (9.8)

1) The potentiometer on the local control panel extends 6.5 mm (0.26 in) from the drive.

6 Mechanical Installation Considerations

6.1 Contents of the Shipment

The shipment contains:

- The drive.
- The terminal cover.
- The operating guide, which provides information about installation, commissioning, and maintenance of the drive.

6.2 Product Labels

6.2.1 Product Labels Overview

The drive and its package have labels that contain information required for legal or regulatory reasons, a unique identification of each component, and other relevant information.

6.2.2 Product Labels on Drives

The product label on the drive contains information to identify the product, and legal and regulatory information. See [Table 43](#) for the label location of the drive.

Table 43: Location of the Label

Enclosure size	Label location
MA01c–MA02c	On the side of drive.
MA01a–MA05a	On the top of drive.

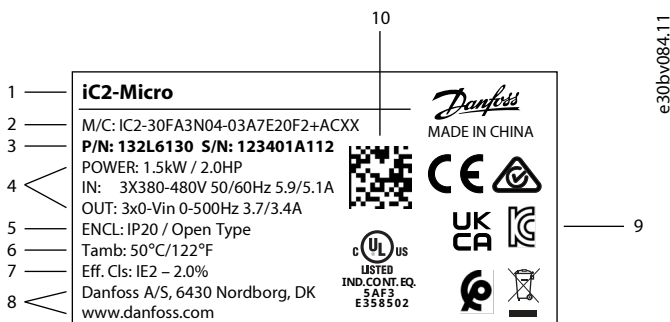

Figure 30: Example of a Product Label

- 1 Product name
- 2 Model code: M/C includes 27 characters of the model code.
- 3 P/N and S/N
 - P/N is the code number of the actual product.
 - S/N contains the serial number.
- 4 Power rating:
 - The 1st line lists the typical motor power rating at the referenced voltages.
 - The 2nd line lists input ratings (voltage range, frequency, and input current at given input voltages).
 - The 3rd line lists output ratings (voltage range, frequency, and rated output currents at the given input voltage).

- 5 Enclosure: States the protection rating of the drive both as an Ingress Protection rating and a UL compliant rating.
- 6 Ambient temperature: States the ambient temperature range without derating needed.
- 7 Efficiency class: Efficiency class according to ErP directive. The value given for 90% frequency/100% current working point.
- 8 Company name, address, and website.
- 9 Warnings and compliance information.
- 10 2D code: The 2D code contains information on the drive, and can be scanned by smart device. The code contains:
 - P/N: Code number.
 - S/N: Serial number.

6.2.3 Package Labels

The package label is placed on the drive packaging and contains information about the drive.

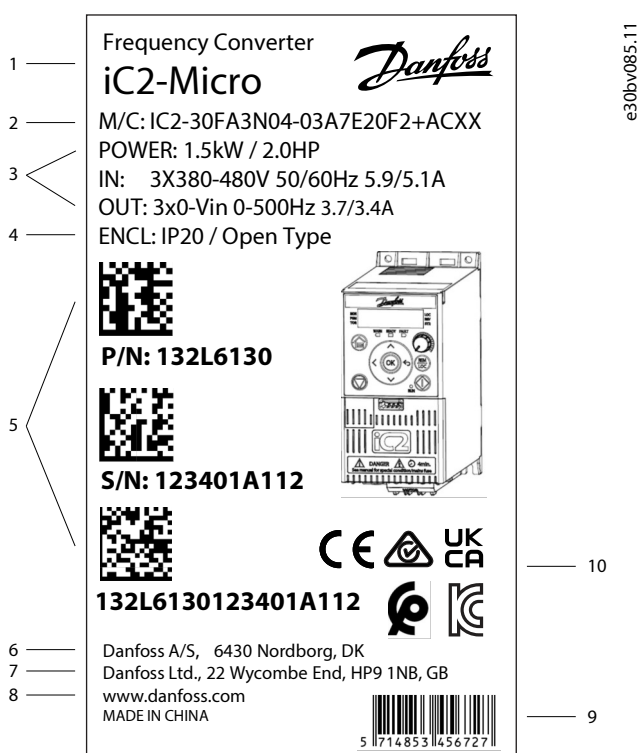

Figure 31: Example of a Package Label

- 1 Product name
- 2 Model code: M/C includes 27 characters of the model code.
- 3 Power rating:
 - The 1st line lists the typical motor power rating at the referenced voltages.
 - The 2nd line lists input ratings (voltage range, frequency, and input current at given input voltages).
 - The 3rd line lists output ratings (voltage range, frequency, and rated output currents at the given input voltage).
- 4 Enclosure: States the protection rating of the drive both as an Ingress Protection rating and a UL compliant rating.
- 5 2D code with information about the order.

-
- 6 Company name, address.
 - 7 UKAC address.
 - 8 Company website.
 - 9 Barcode for European Article Number (EAN).
 - 10 Approval marking required on packaging (more approval markings on the drive).
-

6.3 Recommended Disposal

When the drive reaches the end of its service life, its primary components can be recycled.

Before the materials can be removed, the drive must be disassembled. Product parts and materials can be dismantled and separated. Generally, all metals, such as steel, aluminum, copper and its alloys, and precious metals can be recycled as material. Plastics, rubber, and cardboard can be used in energy recovery. Printed circuit boards and large electrolytic capacitors with a diameter of under 25 mm (1 in) need further treatment according to IEC 62635 guidelines. To ease recycling, plastic parts are marked with an appropriate identification code.

Contact the local Danfoss office for further information on environmental aspects and recycling instructions for professional recyclers. End-of-life treatment must follow international and local regulations.

All drives are designed and manufactured in accordance with Danfoss company guidelines on prohibited and restricted substances. A list of these substances is available at www.danfoss.com.



This symbol on the product indicates that it must not be disposed of as household waste. Do not dispose of equipment containing electrical components together with domestic waste.

It must be handed over to the applicable take-back scheme for the recycling of electrical and electronic equipment.

- Dispose of the product through channels provided for this purpose.
 - Comply with all local and currently applicable laws and regulations.
-

6.4 Storage until Installation

6.4.1 Reforming the Capacitors

For drives that are in storage and do not have voltage applied, maintenance of the capacitors in the drive may be required.

Reforming is required if the drive has been stored without applying voltage for more than 3 years. Reforming is possible only with drives with DC terminals. See [Table 44](#) for DC-link capacitor maintenance and reforming.

When reforming the capacitors:

- The reforming voltage must be 1.35–1.45 times the rated mains voltage. If the DC-link voltage stays at a low level and does not reach approximately $1.41 \times U_{\text{mains}}$, contact the local service agent.
- The supply current draw must not exceed 500 mA.

When the drive is operational, DC-link capacitors that have not been reformed can be damaged.

Table 44: Drive Storage Duration and Reforming Recommendations

Storage duration	Reforming guideline
Under 2 years	No reforming required. Connect to mains voltage.
2–3 years	Connect to mains voltage and wait a minimum of 30 minutes before loading the drive.
Over 3 years	Using a DC supply connected directly to the DC-link terminals of the drive, ramp up the voltage 0–100% of DC-bus voltage in increments of 25%, 50%, 75%, and 100% rated voltage under no load for 30 minutes at each increment. See Figure 32 .

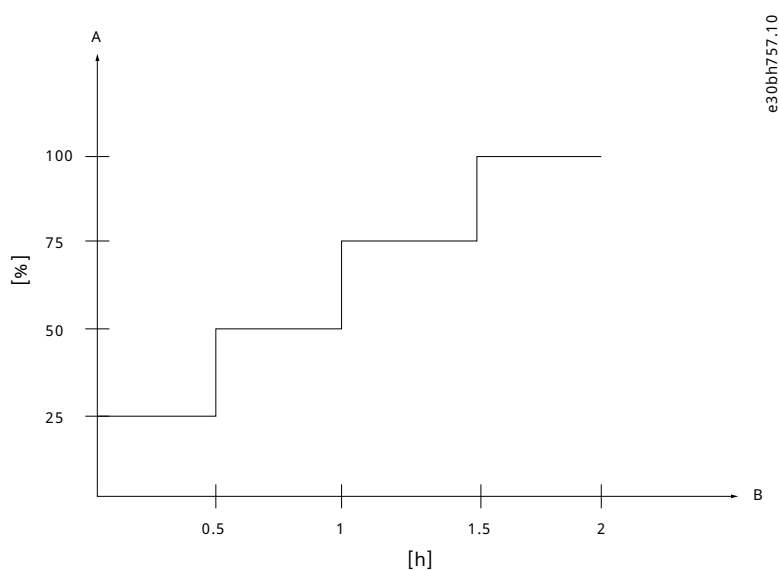

Figure 32: Reforming Procedure for DC Capacitors

A	Reforming voltage (percentage of rated voltage)	B	Hours
---	---	---	-------

Table 45: DC Bus Voltage Ramp-up Value

AC input voltage	Voltage across the DC link
1x100–120 V AC	320 V DC
1x200–240 V AC	320 V DC
3x200–240 V AC	320 V DC
3x380–480 V AC	650 V DC

6.4.2 Safe Transportation and Storage

Follow all information on transportation, storage, and proper handling given in the product-specific documentation. That includes:

- If the drive is stored before installing it, make sure that the ambient conditions agree to the specifications given in [4.2.7.2 Ambient Conditions during Storage](#).
- If the package is kept in storage for more than 4 months, keep it in controlled conditions:
 - Make sure that the temperature variation is small.
 - Make sure that the humidity is less than 50%.

- Keep the drive in its package until installation. After unpacking, protect the drive from dust, debris, and moisture.

6.5 Prerequisites for Installation

6.5.1 Overview of Prerequisites for Installation

To secure the best conditions and operation of the drive in its application, it is recommended to check the following points before selecting a drive:

- Check the operating environment against ambient conditions. See [4.2.7.4 Ambient Conditions during Operation](#).
- Consider the placement of the drive and handling during installation. See [5.1 IP20/Open Type Enclosure Sizes and Dimensions](#) for the weights and mechanical dimensions of the drives.
- Consider needs for access to the drive during operation. See *chapter Mechanical Installation*.
- Consider needs for maintenance access. See [6.7.8 Recommended Space for Service Access](#).

6.5.2 Operating Environment

Make sure that the drive is installed within the specified installation conditions to ensure proper operation and expected lifetime of the product.

Table 46: Operating Environment Specifications

Environment	Specifications
Temperature	The drive must be installed in a location where the operational temperature range is compliant to the specifications of the drive. Consider both temperature at operation and temperature at storage (unpowered drive). If the nominal temperature rating is exceeded, derating must be applied. For more information about derating, see 4.2.7.1 Overview of Ambient Conditions and 4.9.1 Overview of Derating .
Altitude	Ensure that the drive is installed at the allowed altitude for proper cooling and compliance with isolation spacing. At altitudes above 1000 m (3300 ft), derating of drive performance applies. Derating is to be applied to the maximum output current or maximum operational temperature. Ensure that the drive is rated for the actual application. Limitations are stated in <i>Chapter General Technical Data</i> . For more information, see 4.2.7.1 Overview of Ambient Conditions and 4.9.1 Overview of Derating .
Vibration and shock	Ensure that the drive is installed in a location where it is not exposed to vibration and shock levels exceeding its specifications. If exposed to higher levels of vibration and shock, using dampers for installation is recommended. Special requirements are fulfilled when the drive is ordered with marine approval. For more information, see 4.2.7.1 Overview of Ambient Conditions .
Humidity	The drive must be installed in a location, where the humidity level is compliant to the specifications of the drive. If the installation area does not fulfill the required conditions, alternative measures can be taken by selecting other protective cabinets for installation, built-in heating elements, or a dehumidifier. For more information, see 4.2.7.1 Overview of Ambient Conditions .

Table 46: Operating Environment Specifications (continued)

Environment	Specifications
Dust, fiber, and air-borne particles	<p>IP20/Open Type and IP21/UL Type 1 (IP21/Type 1 conversion kit as option) enclosures are not protected against dust, fibers, and other airborne particles, and should be installed in locations where these are not present, or in a dedicated enclosure.</p> <p>Make sure that airborne particles are not clogging the heat sink and fan, because clogging limits the cooling of the drive. The drive detects clogging and reduces performance or stops operation. Do not install the drive in a location where it is exposed to conductive particles.</p> <p>For more information, see 4.2.7.1 Overview of Ambient Conditions.</p> <p>For more information on heat sink and fan maintenance, see 6.6.4 Heat Sink and Fan Maintenance and Service.</p>
Gases	<p>When installing the drive, exposure to gases must be observed. The drive is not intended to be installed in a location where it is exposed to explosive gases. If exposed to corrosive gases, relevant precautions must be taken. These precautions include selecting a drive with a higher protection degree, adding protective coating as an optional selection to the drive, or by installing the drive in a protective cabinet.</p> <p>For more information, see 4.2.7.1 Overview of Ambient Conditions.</p>

6.6 Maintenance Considerations

6.6.1 Regular Maintenance

During the lifetime of the drive, regular maintenance or service actions may be needed, and access to relevant parts of the drive must be ensured.

CAUTION	
	<p>HOT SURFACES</p> <p>The drive contains metal components that are still hot even after the drive has been powered off. Failure to observe the high-temperature symbol (yellow triangle) on the drive can result in serious burns.</p> <ul style="list-style-type: none"> • Be aware that internal components, such as busbars, may be extremely hot even after the drive has been powered off. • Do not touch exterior areas that are marked by the high-temperature symbol (yellow triangle). These areas are hot while the drive is in use and immediately after being powered off.

Typical cases for maintenance include:

- Checking the I/O signal on the drive.
- Regularly checking the power connections and grounding.
- Reading data or parameterizing by connecting a PC to the drive.

6.6.2 Preventive Maintenance Recommendations

Generally, all technical equipment, including Danfoss AC drives, need a minimum level of preventive maintenance. To ensure trouble-free operation and long life of the drive, regular maintenance is recommended. It is also recommended as a good service practice to record a maintenance log with counter values, date, and time describing the maintenance and service actions.

Danfoss recommends the following inspections and service intervals for air-cooled drives/systems.

NOTICE

The service schedule for part replacements can vary depending on operating conditions. Under specific conditions, the combination of stressful operation and environmental conditions work together to reduce the lifetime of the components significantly. These conditions can include, for example, extreme temperature, dust, high humidity, hours of use, corrosive environment, and loading.

For operation in stressful conditions, Danfoss offers the DrivePro® Preventive Maintenance service. DrivePro® services extend the lifetime and increase the performance of the product with scheduled maintenance including customized part replacements. DrivePro® services are tailored to the specific application and operating conditions.

Table 47: Maintenance Schedule for Air-cooled Drives

Component	Inspection interval ⁽¹⁾	Service schedule ⁽²⁾	Preventive maintenance actions
Installation			
Visual inspection	1 year	–	Check for the unusual, for example, for signs of overheating, aging, corrosion, and for dusty and damaged components.
Auxiliary equipment	1 year	According to manufacturer recommendations	Inspect equipment, switchgear, relays, disconnects, or fuses/circuit breakers. Examine the operation and condition for possible causes of operational faults or defects. The continuity check on fuses must be performed by trained service personnel.
EMC consideration	1 year	–	Inspect the wiring regarding the electromagnetic capability and the separation distance between control wiring and power cables.
Cable routing	1 year	–	Check for parallel routing of motor cables, mains wiring, and signal wiring. Avoid parallel routing. Avoid routing cables through free air without support. Check for aging and wearing of the cable insulation.
Control wiring	1 year	–	Check for tightness, damaged or crimped wires, or ribbon wires. Terminate the connections correctly with solid crimped ends. The use of shielded cables and grounded EMC plate, or a twisted pair is recommended.
Clearances	1 year	–	Check that the external clearances for proper airflow for cooling follow the requirements for the frame and product type. For clearances, refer to the local design regulations.
Sealing	1 year	–	Check that the sealing of the enclosure, the covers, and the cabinet doors are in good condition.
Corrosive environments	1 year	–	Conductive dust and aggressive gases, such as sulphide, chloride, and salt mist, can damage the electrical and mechanical components. Air filters do not remove airborne corrosive chemicals. Act based on the findings.
Drive			
Programming	1 year	–	Check that the AC drive parameter settings are correct according to the motor, drive application, and I/O configuration. Only trained service personnel are allowed to perform this action.

Table 47: Maintenance Schedule for Air-cooled Drives (continued)

Component	Inspection interval ⁽¹⁾	Service schedule ⁽²⁾	Preventive maintenance actions
Control panel	1 year	–	Check that the display pixels are intact. Check the event log for warnings and faults. Repetitive events are a sign of potential issues. If necessary, contact a local service center.
Drive cooling capacity	1 year	–	Check for blockages or constrictions in the air passages of the cooling channel. The heat sinks must be free of dust and condensation.
Cleaning and filters	1 year	–	Clean the interior of the enclosure annually, and more frequently if necessary. The amount of dust in the filter or inside the enclosure is an indicator for when the next cleaning or filter replacement is required.
Fans	1 year	3–10 years	Inspect the condition and operational status of all cooling fans. With the power off, the fan axis should feel tight, and spinning the fan with a finger, the rotation should be almost silent and not have abnormal rotation resistance. When in RUN mode, fan vibration, excessive or strange noise is a sign of the bearings wearing, and the fan must be replaced.
Grounding	1 year	–	The drive system requires a dedicated ground wire connecting the drive, the output filter, and the motor to the building ground. Check that the ground connections are tight and free of paint or oxidation. Daisy-chain connections are not allowed. If applicable, braided straps are recommended.
Power cables and wiring	1 year	–	Check for loose connections, aging, insulation condition, and proper torque to the drive connections. Check for proper rating of fuses and continuity check. Observe if there are any signs of operation in a demanding environment. For example, discoloration of the fuse housing can be a sign of condensation or high temperatures.
Vibration	1 year	–	Check for abnormal vibration or noise coming from the drive to ensure that the environment is stable for electronic components.
Spare parts			
Spare parts	1 year	2 years	Stock spares in their original boxes in a dry and clean environment. Avoid hot storage areas. Electrolytic capacitors require reforming as stated in the service schedule. The reforming must be performed by trained service personnel.
Exchange units and units stored for long periods before commissioning	1 year	2 years	Visually inspect for signs of damage, water, high humidity, corrosion, and dust within the visual field of view without disassembly. The exchange units with mounted electrolytic capacitors require reforming as stated in the service schedule. The reforming must be performed by trained service personnel.

1) Defined as the time after the commissioning/startup or the time from the previous inspection.

2) Defined as the time after the commissioning/startup or the time from the previous service schedule actions.

6.6.3 Service Access

To ensure planned and extended drive lifetime, Danfoss recommends regular inspection and service actions for the drive, motor, system, and cabinet/enclosure. To prevent breakdown, danger, and damage, examine, for example, the tightness of terminal connections and dust build-up in the drive at regular intervals depending on the operating conditions.

If the Danfoss drive is operated in environments near the limit or beyond design boundaries, maintenance of the drive is required.

Replace worn or damaged parts with original spare parts. For service and support, contact the local supplier. DrivePro® services extend the lifetime and increase the performance of iC2-Micro Frequency Converters with commissioning and timely scheduled maintenance services. DrivePro® services are tailored to applications and operating conditions.

When planning the installation, proper access for service and maintenance needs must be considered. In general, it is recommended to ensure:

- Access to power cabling and connectors.
- Access to control wiring.
- Access to clean the cooling system (cooling channel and fan filters).
- Access to the port to connect the drive to a PC.

6.6.4 Heat Sink and Fan Maintenance and Service

The heat sink fins pick up dust from the cooling air. If the heat sink is not clean, the drive runs into overtemperature warnings and faults. When necessary, clean the heat sink.

The lifespan of the cooling fan in the drive depends on the fan running time, ambient temperature, and dust concentration. Selecting the fan control mode in *parameter P 6.5.1 Fan Control Mode* and controlling the fan automatically increases the lifespan of the fan. Fan fault can be predicted by the increase of fan bearing noise. If the drive is running in a critical part of a process, it is recommended to replace the fan once these symptoms occur.

Fans can be removed from the drive for cleaning. Replacement of fans is also available from Danfoss.

- For the code numbers of replaceable cooling fans, refer to [8.2 Ordering Accessories and Spare Parts](#).
- For detailed steps on replacing fans, refer to the Fan Replacement Installation Guides for iC2-Micro Frequency Converters.

6.7 Mechanical Installation

6.7.1 Mounting Considerations

When selecting and planning the installation site, observe the following considerations:

- The mounting surface supports the weight of the drive.
- The mounting surface must be non-flammable.
- The drive is installed vertically, but in special cases it can also be mounted in alternate directions. Installing the drive in alternate directions affects the performance of the drive. For more information, see [6.7.3 Mounting Directions](#).
- Proper inlet and outlet spacing secures free airflow over the heat sink to enable proper cooling.
- The drives can be mounted side by side to save space in cabinets, or when mounted on walls in control rooms.
- There must be enough space in front of the drive for operating the control panel.
- Ensure proper space for the installation and placement of cables used for connecting the drive.

WARNING



SHOCK HAZARD

Touching an uncovered motor, mains, or DC connection plug or terminal can result in death or serious injury.

- All plugs and terminal protection covers for the motor, mains, and DC connections must be installed within the IP20 enclosure to provide an IP20 protection rating. If plug and terminal covers are not installed, the protection rating is considered IP00.

- To remove covers or open doors for service access, enough space must be left in front of the drive.

6.7.2 Mounting Locations

The drives are designed for installation in weather-protected environments. For more information, see [4.2.7.1 Overview of Ambient Conditions](#).

The drive is mounted primarily on a wall or in an enclosed cabinet, the mounting surface must be solid, flat, and non-flammable.

6.7.3 Mounting Directions

The drive can be mounted vertically or horizontally, depending on the enclosure size. See [Table 48](#) for more information on the effects of mounting direction on drive performance.

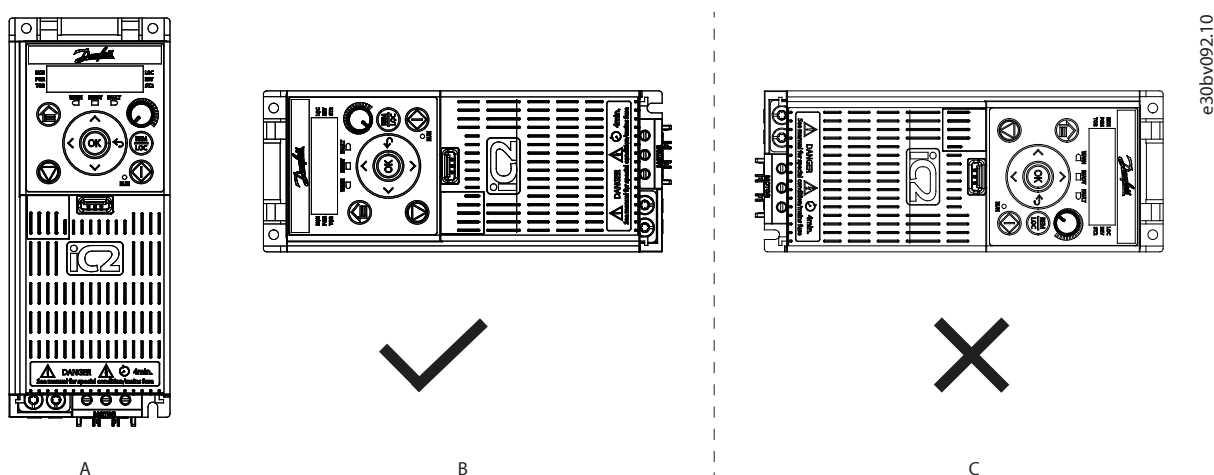

Figure 33: Mounting Directions for Drives

Table 48: Allowed Mounting Directions for IP20/Open Type Rated Drives and Effects of Mounting Direction on Performance

Installation direction	Allowed enclosure size	Effects on performance
A: Vertical installation	All enclosure sizes	None
B: Horizontal installation (Left side downwards)	MA02c, MA01a–MA05a	<ul style="list-style-type: none"> Limited robustness to vibration and shock. Side-by-side mounting not possible.
C: Horizontal installation (Right side downwards)	–	Not allowed for all enclosure sizes.

NOTICE

The IP21/UL Type 1 rated drives are protected against dripping water when installed vertically.

6.7.4 Recommended Screws and Bolts

Check the recommended sizes of screws and bolts for mounting the drive in table [Table 49](#).

Table 49: Recommended Screws and Bolts

Protection rating	Enclosure size	Recommended screw/bolt	Maximum torque [Nm (in-lb)]
IP20/Open Type	MA01c	M4	1.5 (13.3)
	MA02c	M4	1.5 (13.3)
	MA01a	M4	1.5 (13.3)
	MA02a	M4	1.5 (13.3)
	MA03a	M5	1.5 (13.3)
	MA04a	M6	1.5 (13.3)
	MA05a	M6	1.5 (13.3)

6.7.5 Drilling Patterns

When preparing mounting holes for the installation, use the drilling patterns. The drilling pattern equals the mounting plate of the drive.

The required space for cooling, EMC plates, and other extensions is not included in the drilling patterns.

For total space needed, see the drawings in *chapter Exterior and Terminal Dimensions*.

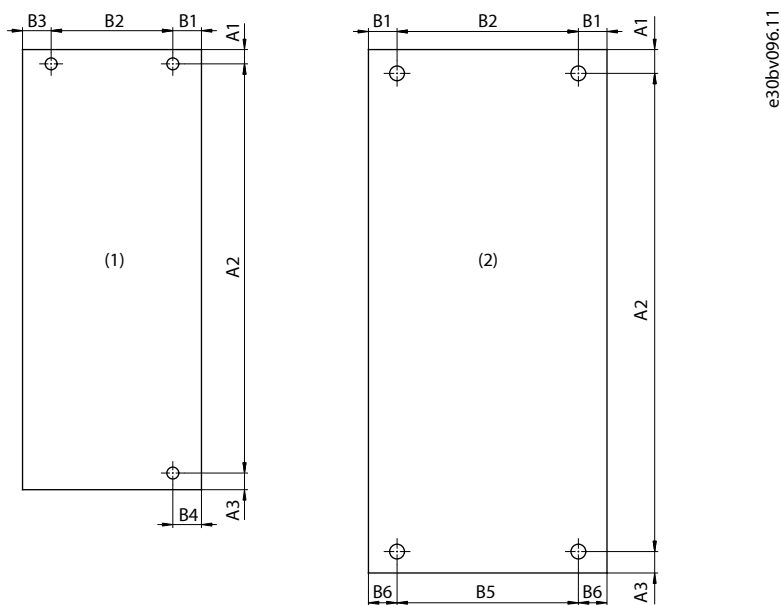

Figure 34: Drilling Patterns

Table 50: Drilling Pattern Dimensions for Wall-mounted Drives

Enclosure size	Drilling pattern	A1 [mm (in)]	A2 [mm (in)]	A3 [mm (in)]	B1 [mm (in)]	B2 [mm (in)]	B3 [mm (in)]	B4 [mm (in)]	B5 [mm (in)]	B6 [mm (in)]
MA01c	1	5.5 (0.22)	140.4 (5.53)	4.1 (0.16)	7.5 (0.30)	55 (2.17)	7.5 (0.30)	7.5 (0.30)	–	–
MA02c	1	5.5 (0.22)	150.5 (5.93)	4.0 (0.16)	6.75 (0.27)	59 (2.32)	9.25 (0.36)	6.75 (0.27)	–	–

Table 50: Drilling Pattern Dimensions for Wall-mounted Drives (continued)

Enclosure size	Drilling pattern	A1 [mm (in)]	A2 [mm (in)]	A3 [mm (in)]	B1 [mm (in)]	B2 [mm (in)]	B3 [mm (in)]	B4 [mm (in)]	B5 [mm (in)]	B6 [mm (in)]
MA01a	1	4.8 (0.19)	140.4 (5.53)	4.8 (0.19)	7.5 (0.30)	55 (2.17)	7.5 (0.30)	7.5 (0.30)	–	–
MA02a	1	4.8 (0.19)	176.4 (6.94)	4.8 (0.19)	8.0 (0.31)	59 (2.32)	8.0 (0.31)	8.0 (0.31)	–	–
MA03a	1	7.6 (0.30)	226.1 (8.90)	4.8 (0.19)	10.5 (0.41)	69 (2.72)	10.5 (0.41)	8.1 (0.32)	–	–
MA04a	2	11.1 (0.44)	272.4 (10.72)	8.5 (0.33)	14 (0.55)	97 (3.82)	–	–	99 (3.90)	13 (0.51)
MA05a	2	10 (0.39)	315 (12.4)	10 (0.39)	12.5 (0.49)	140 (5.5)	–	–	140 (5.5)	12.5 (0.49)

6.7.6 Placement of the Drive in the Installation

Before mounting the drive, prepare the mounting location with appropriate fasteners so the drive can be positioned safely. Make sure that there is enough space to handle the drive safely during installation.

Lower screws or bolts can be mounted before installation. Position the drive on the lower bolts, and mount the upper screws or bolts. The broken torque for screw holes on the mounting surface must be no less than 1.5 Nm (13.3 in-lb).

6.7.7 Cooling

For proper cooling for the drives, ensure that there is sufficient clearance above and below the drive. See [Table 51](#) for details on the required cooling clearances.

For all installations, the temperature of the installation site must be kept within the specified operating temperature range by ventilation or cooling. The quality of the cooling air must comply with the environmental conditions as defined in the technical specifications (dust, airborne particles, chemical substances).

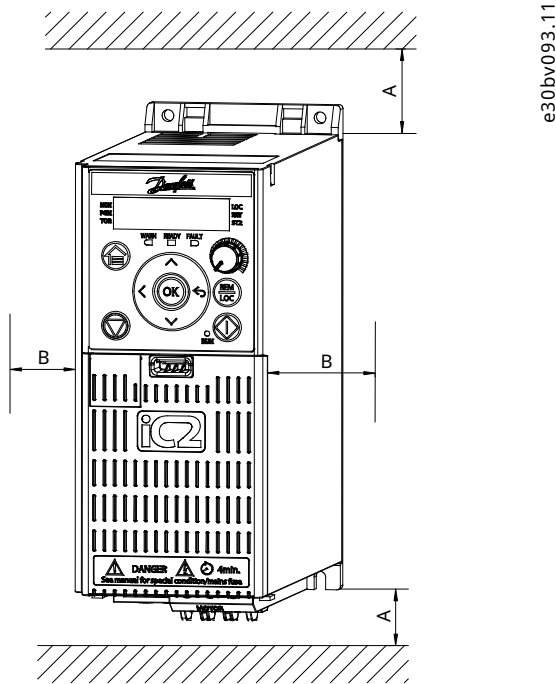

Figure 35: Minimum Clearance for Cooling

Table 51: Minimum Cooling Clearances for IP20/Open Type Drives

Enclosure size	A [mm (in)]	B [mm (in)]	Cooling type
MA01c	100 (3.9)	<ul style="list-style-type: none"> • 0 (0) at 40 °C (104 °F). • 10 (0.39) and above at 50 °C (122 °F). 	Natural air cooling
MA02c, MA01a–MA05a	100 (3.9)	0 (0)	Forced air cooling

6.7.8 Recommended Space for Service Access

To ensure access to the drive for service and maintenance, it is recommended to reserve sufficient space around the drive.

The general recommendations include:

- Enough space in the front of the drive for removing covers, and access to the control board.
- Enough space below the drive to access the cooling channel entry for cleaning or replace fans.

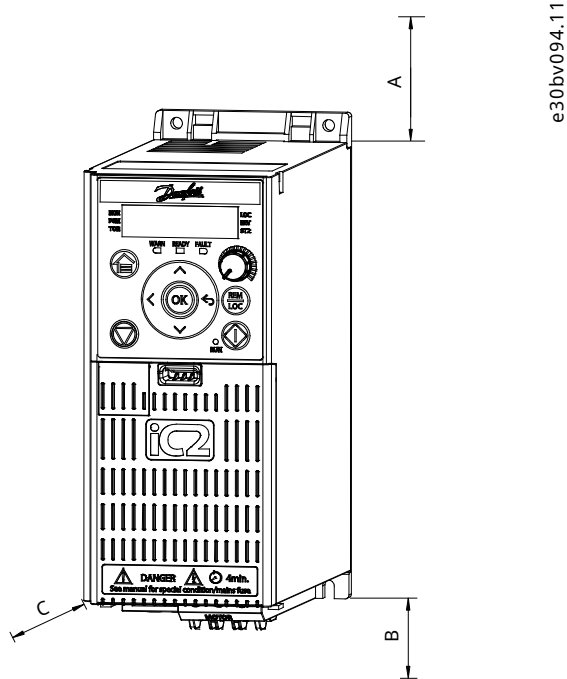

Figure 36: Recommended Clearance for Service Access

Table 52: Recommended Clearances for Service Access

Enclosure size	Recommended space for access		
	Above (A) [mm (in)]	Below (B) [mm (in)]	Front (C) [mm (in)]
All enclosure sizes	100 (3.9) ⁽¹⁾	200 (7.9) ⁽¹⁾	100 (3.9)

1) Sufficient space to the cooling duct, exceeding need for cooling. Alternatively, unplug the drive, and remove from the installation for service.

7 Electrical Installation Considerations

7.1 Electrical Installation Precautions

WARNING



INDUCED VOLTAGE

Induced voltage from output motor cables that run together can charge equipment capacitors, even with the equipment turned off and locked out/tagged out. Failure to run output motor cables separately, or to use shielded cables, could result in death or serious injury.

- Run output motor cables separately or use shielded cables.
- Simultaneously lock out/tag out all the drives.

CAUTION

THERMISTOR INSULATION

Risk of personal injury or equipment damage.

- To meet the PELV insulation requirements, use only thermistors with reinforced or double insulation.

NOTICE

EXCESSIVE HEAT AND PROPERTY DAMAGE

Overcurrent can generate excessive heat within the drive. Failure to provide overcurrent protection can result in risk of fire and property damage.

- Additional protective devices such as short-circuit protection or motor thermal protection between drive and motor is required for applications with multiple motors.
- Input fusing is required to provide short-circuit and overcurrent protection. If fuses are not factory-supplied, the installer must provide them. Refer to the product-specific documentation for fuse specifications.

NOTICE

PROPERTY DAMAGE

Protection against motor overload is not included in the default setting. The ETR function provides class 20 motor overload protection. Failure to set the ETR function means that motor overload protection is not provided and property damage can occur if the motor overheats.

- Enable the ETR function. Refer to the application guide for more information.

7.2 Wiring Diagram

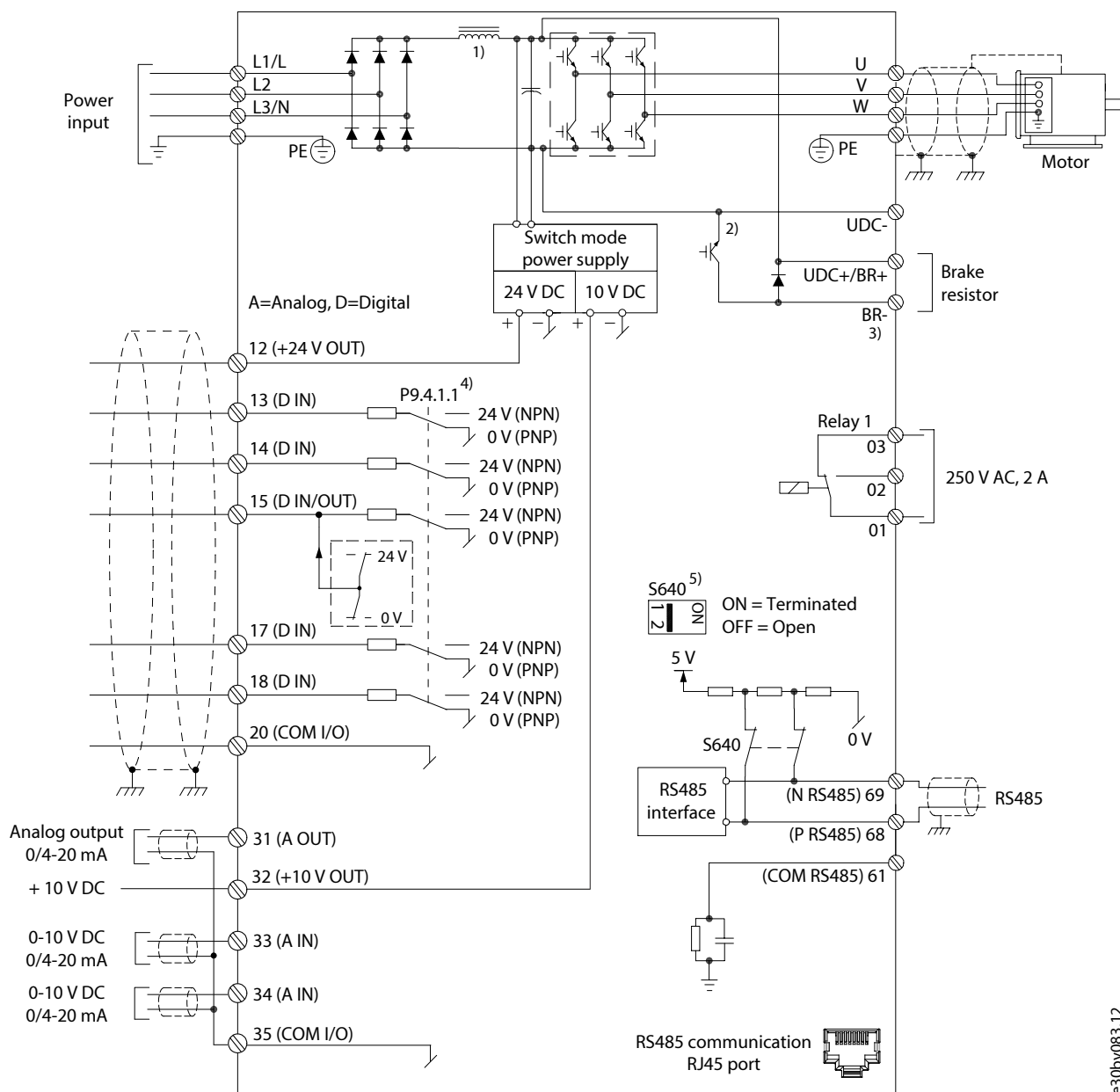

e30bv083.12

Figure 37: Wiring Diagram

- 1 Single DC choke in MA05a.
- 2 Built-in brake chopper is only applicable to drives in the power range of 3x380–480 V 2.2 kW (3.0 hp) and above, and 3x200–240 V 1.5 kW (2 hp) and above.
- 3 No BR terminals for 1x100–120 V, 1x200–240 V, 3x200–240 V 0.37–0.75 kW (0.5–1.0 hp), and 3x380–480 V 0.37–1.5 kW (0.5–2.0 hp) drives.
- 4 Select the PNP or NPN mode via **parameter P 9.4.1.1 Digital I/O mode** (PNP=Source, NPN=Sink).
- 5 Use switch S640 (bus terminal) to enable termination on the RS485 port (terminals 68 and 69).

7.3 Grid Type and Protection

7.3.1 Grid Types

The drive can operate in different network types with rated network supply voltage:

- TN-S
- TN-C
- TN-C-S
- TT
- IT (only supported by C4 version)
- Delta-grounded grids (only supported by C4 version)

For detailed information about the parameters related to grid types, refer to the application guide.

7.3.2 Currents on Protective Earth and Potential Equalization/Leakage Currents

A properly dimensioned protective earth (PE) setup is essential for the safety of the drive system protecting against electric shock. The PE connections of the drive installation ensure that the drive system remains safe preventing that single fault currents generate hazardous voltages on accessible conductive parts, such as conductive enclosure parts.

The drive must be installed according to the requirement for PE connection and supplementary protective bonding as specified in EN 60364-5-54:2011 cl. 543 and 544. For the automatic disconnection if there is a fault at the motor side, it must be ensured that the impedance of the PE connection between drive and motor is sufficiently low to ensure compliance to IEC/EN 60364-4-41:2017 cl. 411 or 415. The impedance must be verified by initial and periodic test according to IEC/EN 60364-4-41:2017.

Local requirements may also apply.

Designing the system according to IEC/EN 61800-5-1:2017 ensures the suitability for the connection of PE and protective bonding of accessible conductive parts according to EN 60364-5-54:2011. When the drive is used as a component inside specific applications, special requirements for the proper connection to the PE, for example those specified in EN 60204-1:2018 and IEC/EN 61439-1:2021, can apply.

In low-voltage networks currents can arise on the protective conductor (PE) and equipotential bonding conductors and structures connected to earth potential as an undesirable effect. Since there are different causes for these currents, it is beneficial to know them to avoid them.

A drive setup consists of a mains supply, the drive inverter, its cabling, and a motor with the load side. Due to the behavior of the active and passive components and the electrical setup of the installation, several phenomena may appear resulting in currents on the PE conductor.

- Inductive coupling due to asymmetry in mains cables and/or busbars can cause PE current at the mains frequency and its harmonics.
- Inductive coupling due to asymmetry in motor cables can cause PE current at the motor fundamental frequency.
- As part of the EMI filter DC link, capacitive decoupling to PE can cause PE currents at 150 Hz/180 Hz.
- Voltage distortion/harmonic content on the mains can typically cause PE currents in the 150 Hz–2000 Hz range.
- Common-mode currents due to motor cable capacitance from motor phases to PE typically result in PE currents at the switching frequency and harmonics typically above 2 kHz.

The PE current is made up of several contributions and depends on various system configurations:

- RFI filtering
- Motor cable length
- Motor cable shielding
- Drive power

7.3.3 PE Current Measurement

As the currents have different frequencies, it is not useful to measure an effective value only. Instead, it is required to perform a frequency/FFT measurement. This can be done by using an appropriate oscilloscope or specific measuring equipment. Just analyzing the effective value with a current clamp at the PE connection of the drive leads to insufficient and misleading results.

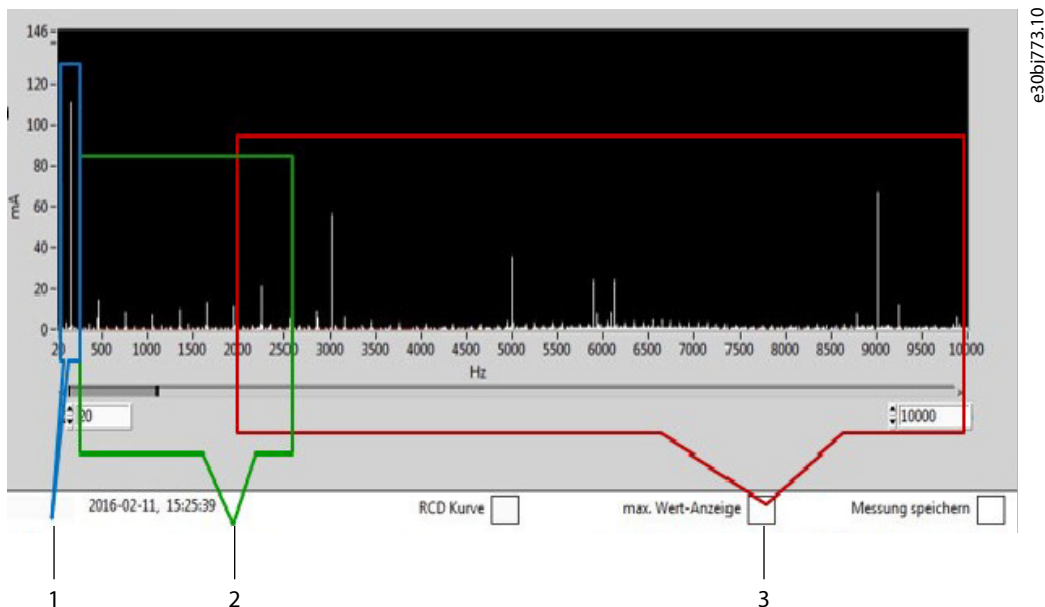

Figure 38: Example of FFT Measurement

- | | |
|--|---|
| <p>1 $f < 50$ Hz: Typical for inductive coupling in unsymmetrical cables and conductor.</p> | <p>2 $f = 150\text{--}2500$ Hz: Typical harmonic components in grid.
$f = 150$ Hz: Common-mode current typical due to rectifier with DC link.</p> |
| <p>3 $f > 2$ kHz: Typical common-mode current due to capacitive coupling between cable/motor and ground.</p> | |

⚠ WARNING**ELECTRICAL SHOCK HAZARD - LEAKAGE CURRENT HAZARD >3.5 MA**

Leakage currents exceed 3.5 mA. Failure to connect the drive properly to protective earth (PE) can result in death or serious injury.

- Ensure reinforced protective earthing conductor according to IEC 60364-5-54 cl. 543.7 or according to local safety regulations for high touch current equipment. The reinforced protective earthing of the drive can be done with:
 - a PE conductor with a cross-section of at least 10 mm² (8 AWG) Cu or 16 mm² (6 AWG) Al.
 - an extra PE conductor of the same cross-sectional area as the original PE conductor as specified by IEC 60364-5-54 with a minimum cross-sectional area of 2.5 mm² (14 AWG) (mechanically protected) or 4 mm² (12 AWG) (not mechanically protected).
 - a PE conductor completely enclosed with an enclosure or otherwise protected throughout its length against mechanical damage.
 - a PE conductor part of a multi-conductor power cable with a minimum PE conductor cross-section of 2.5 mm² (14 AWG) (permanently connected or pluggable by an industrial connector. The multi-conductor power cable shall be installed with an appropriate strain relief).
- NOTE: In IEC/EN 60364-5-54 cl. 543.7 and some application standards (for example IEC/EN 60204-1), the limit for requiring reinforced protective earthing conductor is 10 mA leakage current.

⚠ WARNING**LEAKAGE CURRENT HAZARD**

Leakage currents can exceed 5%. Failure to ground the drive properly can result in death or serious injury.

- Ensure that the minimum size of the ground conductor complies with the local safety regulations for high touch current equipment.

Protective earth (PE) and equipotential bonding are usually connected to one another so that equipotential bonding currents are also distributed over the entire PE system.

PE currents and their impact on the system can be avoided or reduced by using short motor cables, symmetrical cables (especially for current ratings > 50 A), or shielded cables with low capacitance between conductors and PE.

7.3.4 Residual Current Device (RCD) Protection

Residual current devices (RCD) may be used to provide additional protection against electrical shock and fire hazards due to fault currents because of insulation faults or high leakage currents. Additional consideration is needed when RCDs are used in front of the drive. RCDs must always be installed according to local regulations.

⚠ WARNING**ELECTRICAL SHOCK AND FIRE HAZARD – RCD COMPLIANCE**

The drive can cause a DC fault current in the PE conductor. Failure to use a Type B residual current-operated protective device (RCD) can lead to the RCD not providing the intended protection and therefore can result in death, fire, or other serious hazard.

- When an RCD is used for protection against electrical shock or against fire, only a Type B device is allowed on the supply side.

RCD/RCM devices cannot differentiate between operating and fault currents, and their function can be impaired. RCDs can be triggered even though there is no insulation fault in the installation.

Current measured by an RCD/RCM on mains phases might differ from the measured PE current. This is due to magnetic coupled PE current not being present on mains phases.

The frequency characteristic of Type B RCDs is not completely standardized, and vendor-specific differences are to be expected in the upper frequency range. Consult the documentation of the RCD in question for more information.

7.3.5 Isolation Monitoring Devices

When operating on an IT grid, isolation monitoring devices can be used for observing the integrity of the isolation in the supply cabling, motor, motor cabling, and the drive.

The typical applications are:

- Preventive detection of degradation of the isolation system.
- Ground fault detection on IT mains.

The isolation monitor is a key component in an IT mains installation. It allows preventive maintenance and warns whenever a ground fault occurs. Several types of isolation monitors exist with different operation principles, for example, DC-voltage injection, DC voltage with alternating polarity injection and current injection. Not all isolation monitors are compatible with drive systems due to capacitances to ground and drives producing common-mode voltages. It is essential that the isolation monitor used in a drive system installation is compatible with drives.

7.4 EMC-compliant Installation

7.4.1 EMC-compliant Installation Guidelines

This chapter gives a general introduction to proper EMC-compliant installation practice.

To obtain an EMC-compliant installation, follow the instructions provided in the operating guide supplied with the drive.

See [Figure 39](#) for an example on how to ensure a proper EMC-compliant installation.

e30bv100.10

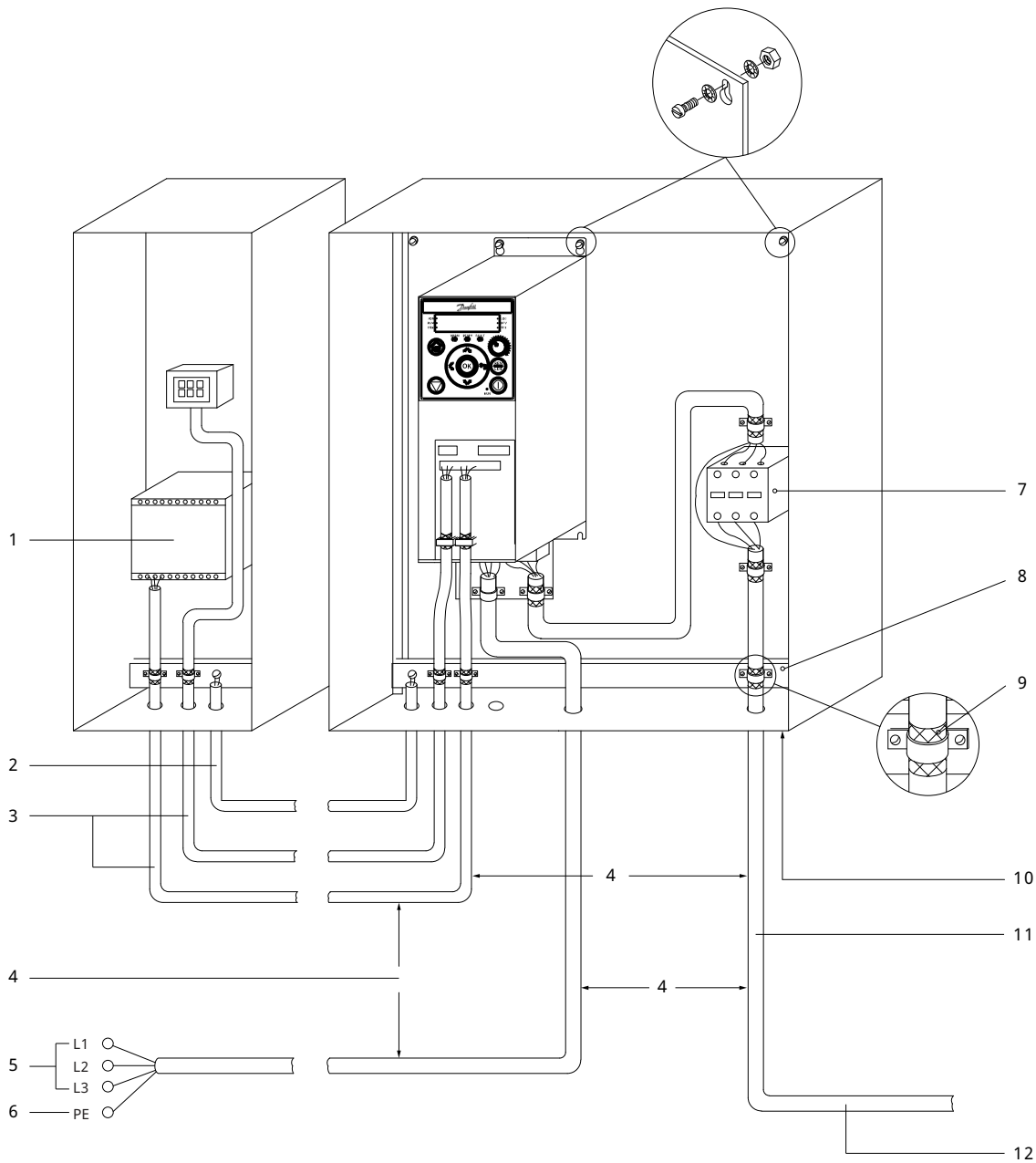

Figure 39: Example of Proper EMC Installation

1	Programmable logic controller (PLC)	2	Minimum 16 mm ² (6 AWG) equalizing cable
3	Control cables	4	Minimum 200 mm (7.9 in) between control cables, motor cables, and mains cables
5	Mains supply	6	Reinforced protective earth
7	Output contactor, and so on.	8	Grounding rail
9	Cable insulation stripped	10	All cable entries in one side of panel
11	Motor cable	12	Connecting to motor (3 phases and protective earth)

7.4.2 Power Cables and Grounding

Depending on the installation and the required EMC compliance level, using shielded cables is required for motor, brake, and DC connections. Alternatively, unshielded cables within a metal conduit can also be used.

If a shielded cable is used, it is important to connect the shield through a 360° connection. Connect the shield with the supplied clamps, and avoid pigtails, as they limit the shielding functionality.

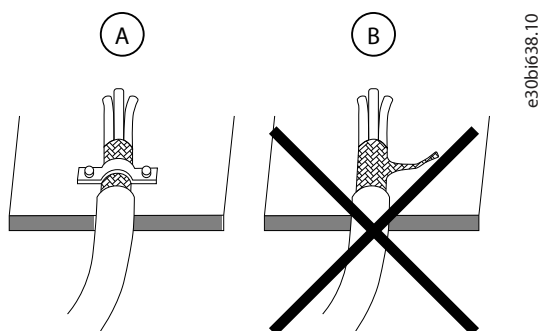

Figure 40: Installation of Cable Shield

NOTICE

SHIELDED CABLES

If shielded cables or metal conduits are not used, the unit and the installation do not meet regulatory limits.

If a non-shielded wire is used to connect a brake resistor, it is recommended to twist the wires to reduce the electric noise.

Ensure that the cables are as short as possible to reduce interference level from the entire system and minimize losses.

WARNING



ELECTRICAL SHOCK HAZARD - LEAKAGE CURRENT HAZARD >3.5 MA

Leakage currents exceed 3.5 mA. Failure to connect the drive properly to protective earth (PE) can result in death or serious injury.

- Ensure reinforced protective earthing conductor according to IEC 60364-5-54 cl. 543.7 or according to local safety regulations for high touch current equipment. The reinforced protective earthing of the drive can be done with:
 - a PE conductor with a cross-section of at least 10 mm² (8 AWG) Cu or 16 mm² (6 AWG) Al.
 - an extra PE conductor of the same cross-sectional area as the original PE conductor as specified by IEC 60364-5-54 with a minimum cross-sectional area of 2.5 mm² (14 AWG) (mechanically protected) or 4 mm² (12 AWG) (not mechanically protected).
 - a PE conductor completely enclosed with an enclosure or otherwise protected throughout its length against mechanical damage.
 - a PE conductor part of a multi-conductor power cable with a minimum PE conductor cross-section of 2.5 mm² (14 AWG) (permanently connected or pluggable by an industrial connector. The multi-conductor power cable shall be installed with an appropriate strain relief).
- NOTE: In IEC/EN 60364-5-54 cl. 543.7 and some application standards (for example IEC/EN 60204-1), the limit for requiring reinforced protective earthing conductor is 10 mA leakage current.

Ground the drive according to applicable standards and directives. Use a dedicated ground wire for input power, motor power, and control wiring. Terminate individual ground wires separately, complying with the dimension requirements.

Follow motor manufacturers wiring requirements when connecting to the motors.

Keep the grounding wire as short as possible. The minimum cable cross-section for the ground wires is 10 mm² (7 AWG). Alternatively, it is possible to use 2 rated ground wires terminated separately. Do not ground drives to each other in a daisy-chain fashion (see [Figure 41](#)).

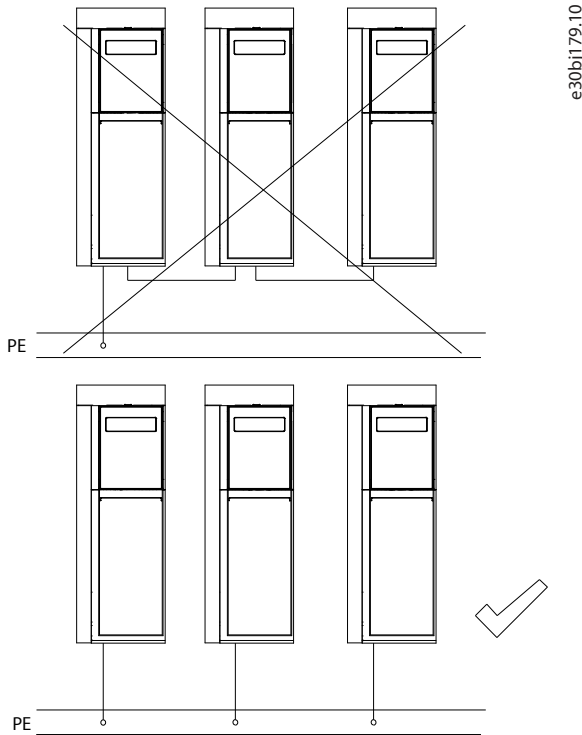

Figure 41: Grounding Principle

7.4.3 Control Cables

Use shielded cables for control wiring and avoid placing control wires next to power cables. Ideally, isolate the control cables from the power cables (mains, motor, brake, and DC) by routing them separately or keep a minimum distance of 200 mm (7.9 in). For optional shielding, both ends of the shielded control cables must have the shield connected.

Keep 24 V signal cables apart from 110 V or 230 V signals from relays, for example.

When the drive is connected to a thermistor, ensure that the wiring is shielded and reinforced/double isolated. A 24 V DC supply voltage is recommended.

For communication purpose and command/control lines, follow the particular protocol standard.

7.5 Galvanic Isolation

PELV offers protection through extra low voltage. Protection against electric shock is ensured when the electrical supply is of the PELV type and the installation is made as described in local/national regulations on PELV supplies.

All control terminals and relay terminals 01–03 comply with PELV (protective extra low voltage).

Galvanic (ensured) isolation is obtained by fulfilling requirements for higher isolation and by providing the relevant creepage/clearance distances. These requirements are described in the EN 61800-5-1 standard.

The components that make up the electrical isolation, as shown in [Figure 42](#), also comply with the requirements for higher isolation and the relevant test as described in EN 61800-5-1.

The PELV galvanic isolation can be shown in 3 locations (see [Figure 42](#)):

To maintain PELV, all connections made to the control terminals must be PELV, for example, the thermistor must be reinforced/double insulated.

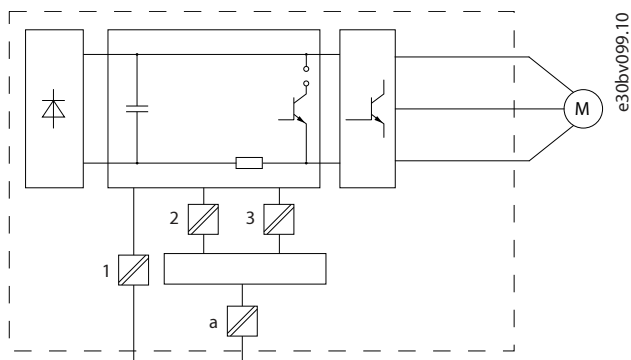

Figure 42: Galvanic Isolation

1	Customer relay	2	Communication between power card and control card
3	Power supply (SMPS) for control card	a	Functional galvanic isolation for the RS485 standard bus interface

⚠ WARNING

SAFETY RECOMMENDATIONS

Failure to follow the recommendations could result in death or serious injury.

- Before touching any electrical parts, ensure that other voltage inputs have been disconnected, such as load sharing (linkage of DC link) and the motor connection for kinetic backup.
- Observe the discharge time stated in the *chapter Safety* in the operating guide.

7.6 Ground Leakage Current

Follow national and local codes regarding protective grounding of equipment with a leakage current >3.5 mA. Drive technology implies high frequency switching at high power. This switching generates a leakage current in the ground connection. A fault current in the drive at the output power terminals might contain a DC component, which can charge the filter capacitors and cause a transient ground current. The ground leakage current is made up of several contributions and depends on various system configurations including:

- RFI filtering.
- Shielded motor cables.
- Motor cable length.
- Drive power.

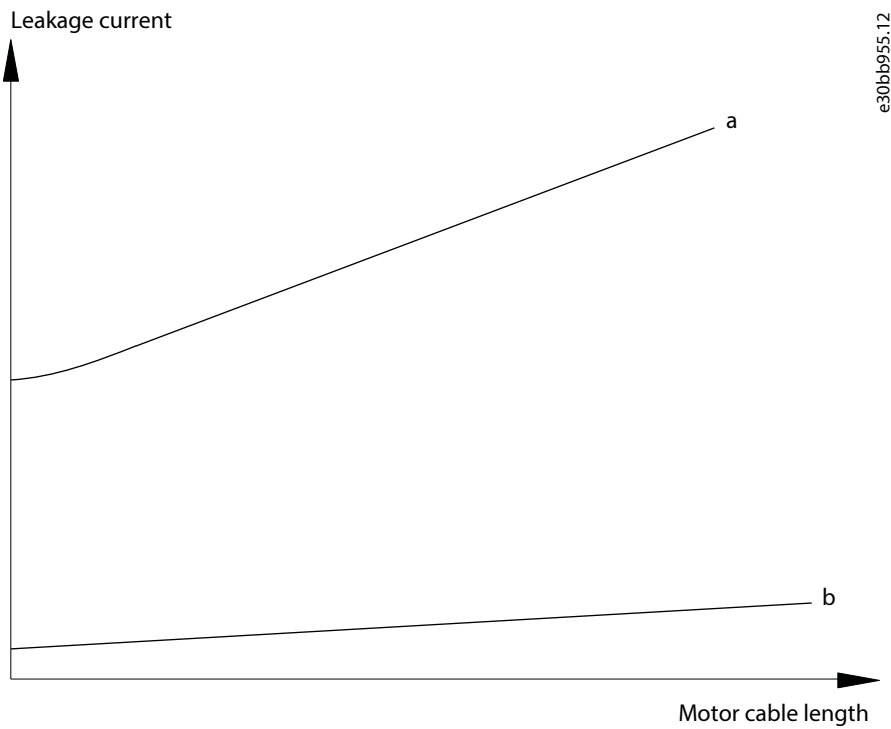

Figure 43: Influence the Cable Length and Power Size on Leakage Current, $P_a > P_b$

The leakage current also depends on the line distortion.

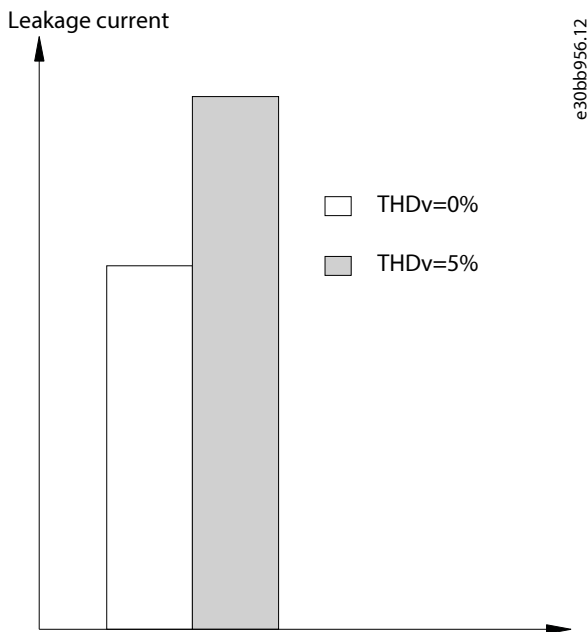

Figure 44: Influence of Line Distortion on Leakage Current

EN/IEC61800-5-1 (Power Drive System Product Standard) requires special care if the leakage current exceeds 3.5 mA. Reinforce grounding with the following protective ground connection requirements:

- Ground wire (terminal 95) of at least 10 mm² (8 AWG) cross-section.
- 2 separate ground wires that comply with the dimensioning rules.

See EN/IEC61800-5-1 for further information.

7.7 Motor Installation

7.7.1 Motor Installation Considerations

When selecting an AC drive, consider the following aspects:

- **Torque limits:** When an AC drive controls a motor, torque limits can be set for that motor. Selecting a frequency converter with an apparent power rating that matches the rated current or power of the motor ensures that the required load can be driven reliably. However, an extra reserve is necessary to enable smooth acceleration of the load and also cater for occasional peak loads.
- **Current ratings** of the drive and the motor. Power rating is only a rough guide.
- Correct **operating voltage**.
- Ensure that the motor withstands the **maximum peak voltage** on the motor terminals.
- **Required speed range:** Operation above nominal motor supply frequency (50 Hz or 60 Hz) is possible only at reduced power. Operation at low frequency and high torque can cause the motor to overheat due to lack of cooling.
- **Derating:** Synchronous motors require derating, typically by 2–3 times, because the power factor, and hence the current, can be high at low frequency.
- **Overload performance:** The drive limits current to 150% of full current quickly. A standard, fixed-speed motor tolerates these overloads.
- **Stopping the motor:** If it is necessary to stop the motor quickly, using a brake resistor should be considered (select braking terminals on iC2-Micro Frequency Converters) to absorb the energy.
- The **direction of rotation** when connected to the frequency converter's output terminals U-V-W follows the specification from NEMA MG1 and IEC 60034-8. Ensure correct direction of rotation in the end application to avoid a potential hazardous situation. If only 1 direction of rotation is required, it is recommended to parameterize the drive to operate in the relevant direction only.

For the basics of protecting the motor insulation and bearings in AC drive systems, see [7.7.3 Motor Insulation](#) and [7.7.4 Bearing Currents](#).

7.7.2 Supported Motor Types

The iC2-Micro Frequency Converters are compatible with:

- Asynchronous AC induction motors.
- Synchronous permanent magnet motors.

The drives are motor-independent, and can be connected to any brand of motor. For instructions on how to set up motors, refer to the application guide.

For detailed information about the supported motor types, contact Danfoss.

7.7.3 Motor Insulation

Because of rapid switching and reflections in the cables, motors are subject to more voltage stress in the windings when fed by AC drives than with sinusoidal supply voltage.

Regardless of frequency, the AC drive output comprises pulses of approximately the drive DC-bus voltage with a short rise time. The pulse voltage can almost double at the motor terminals, depending on the attenuation and reflection properties of the motor cable and the terminals. This stresses the motor winding insulation and can cause it to break down, resulting in possible sparking.

Depending on voltage and cable length, a filter or reinforced insulation of the motor is required.

7.7.4 Bearing Currents

AC drives can cause common-mode voltages which induce voltages across motor bearings, leading to current flow through motor bearings. To protect against bearing currents, use either sine-wave filters or common-mode filters.

Due to their operating principle, AC drives produce a series of unwanted secondary effects:

- Motor winding isolation stress
- Bearing stress
- Acoustic switching noise in the motor
- Electromagnetic interference

In most applications, these effects are at an acceptable level, but sometimes these effects must be mitigated. For the mitigation of these effects, filters are installed at the output of the drives. The most commonly known filters are dU/dt filters, sine-wave filters, and common-mode filters.

The steep switching rate of the AC drive output voltage combined with the inherent common-mode voltage produced by the AC drive causes shaft voltage. Motor asymmetries, or the use of asymmetric motor cables especially in high-power applications where the motor current exceeds 100–200 A can also cause shaft voltage.

Table 53: Mitigating Bearing Current Effects with Filters

Type of filter	
dU/dt filters	dU/dt filters reduce the slew rate of the voltage pulses at the drive output to rates which are typically below 500 V/μs. This reduces the stress of the motor winding isolation. The voltage shape remains pulse-width modulated. The optional dU/dt filters also protect the motor insulation system and reduce bearing currents.
Sine-wave filters	A sine-wave filter reduces bearing currents and voltage reflections, and it also reduces motor noise. If an output transformer is used, the sine-wave filter eliminates high-frequency components that could stress the transformer. The sine-wave filter also allows the use of considerably longer motor cables.
Common-mode filters	Common-mode filters reduce high-frequency common-mode currents between AC drive and motors. High-frequency common-mode filters are a good solution for reducing electric bearing current stress, but the use of such filters does not eliminate the need of an EMC-compliant installation.

7.7.5 Motor Thermal Protection

During operation, the motor connected to the drive can be monitored to avoid overheating.

Depending on the criticality of overheating, different monitoring methods can be used:

- Built-in Electronic Thermal Motor monitoring
- Externally connected sensors (PTC according to DIN 44081)

Electronic thermal relay function

The electronic thermal relay (ETR) function protects the motor from thermal overload without connecting an external device by estimating the motor temperature based on present load and time.

The ETR function meets the relevant requirements of UL 61800-5-1, including the Thermal Memory Retention requirement, and ensures a class 20 protection level.

ETR is an electronic feature that simulates a bimetal relay based on internal measurements. The characteristic is shown in [Figure 45](#).

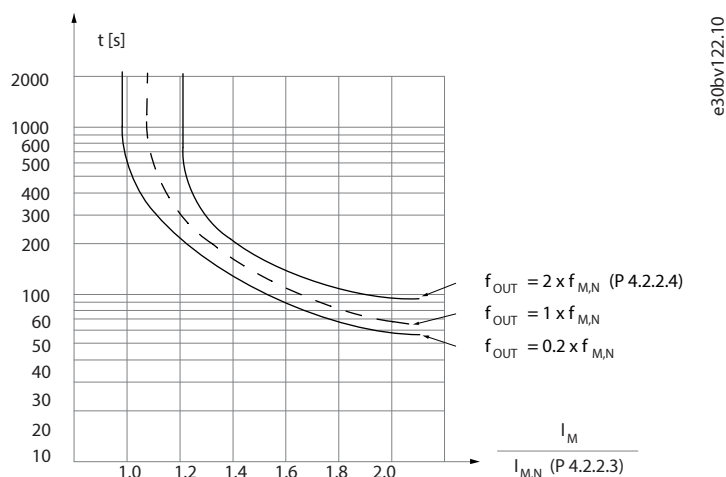
Figure 45: ETR

The X-axis shows the ratio between I_{motor} and $I_{\text{motor nominal}}$. The Y-axis shows the time in seconds before the ETR cuts off and trips the drive. The curves show the characteristic nominal speed at twice the nominal speed and at 0.2 x the nominal speed. At lower speed, the ETR cuts off at lower heat due to less cooling of the motor. In that way, the motor is protected from being overheated even at low speed. The ETR feature calculates the motor temperature based on actual current and speed. The calculated temperature is visible as a readout parameter in *parameter P 4.1.5 Motor Thermal Load*.

Externally connected sensors

Monitoring can be done by using analog input or digital inputs on the I/O board or with functional extension options. The sensors must be either double isolated or have reinforced insulation between motor and drive control.

The analog input allows measurement of the temperature by using external sensors.

Using a digital input allows monitoring with a PTC sensor. The PTC must be connected from 24 V DC to the digital input.

For more information on configuring the functionalities, refer to the application guide.

7.8 Extreme Running Conditions

Short circuit (motor phase to phase)

The drive is protected against short circuits by current measurement in each of the 3 motor phases or in the DC link. A short circuit between 2 output phases causes an overcurrent in the drive. The drive is turned off individually when the short-circuit current exceeds the allowed value (*Fault 16, short circuit*).

Switching on the output

Switching on the output between the motor and the drive is fully allowed and does not damage the drive. However, fault messages may appear.

Motor-generated overvoltage

The voltage in the DC link is increased when the motor acts as a generator. This occurs in following cases:

- The load drives the motor (at constant output frequency from the drive).
- If the inertia moment is high during deceleration (ramp-down), the friction is low and the ramp-down time is too short for the energy to be dissipated as a loss in the drive, the motor, and the installation.
- Incorrect slip compensation setting may cause higher DC-link voltage.

The control unit may attempt to correct the ramp if possible (*parameter P 2.3.1 Overvoltage Controller Enable*). The drive turns off to protect the transistors and the DC-link capacitors when a certain voltage level is reached.

To select the method used for controlling the DC-link voltage level, see *parameter P 2.3.1 Overvoltage Controller Enable*, *parameter P 3.2.1 Enable Brake Chopper*, and *parameter P 4.4.2.1 Enable AC-Brake*.

Mains drop-out

During a mains drop-out, the drive keeps running until the DC-link voltage drops below the minimum stop level, which is:

- 180 V for 1x100–120 V.
- 180 V for 1x200–240 V.
- 202 V for 3x200–240 V.
- 314 V for 3x380–480 V.

The mains voltage before the drop-out and the motor load determines how long it takes for the inverter to coast.

Static overload in VVC+ mode

When the drive is overloaded, the torque limit in *parameter P 5.10.1 Motor Torque Limit/parameter P 5.10.2 Regenerative Torque Limit* is reached, the control unit reduces the output frequency to reduce the load.

If the overload is excessive, an overcurrent which makes the drive cut out after approximately 5–10 s may occur.

Operation within the torque limit is limited in time (0–60 s) in *parameter P 5.10.6 Trip Delay at Torque Limit*.

Torque limit

The torque limit protects the motor from being overloaded independent of the speed. Torque limit is controlled in *parameter P 5.10.1 Motor Torque Limit* and *parameter P 5.10.2 Regenerative Torque Limit*. *Parameter P 5.10.6 Trip Delay at Torque Limit* controls the time before the torque limit warning trips.

Current limit

Parameter P 2.7.1 Output Current Limit % controls the current limit, and *parameter P 2.7.5 Trip Delay at Current Limit* controls the time before the current limit warning trips.

Minimum speed limit

Parameter P 5.8.3 Motor Speed Low Limit [Hz] sets the minimum output speed that the drive can provide.

Maximum speed limit

Parameter P 5.8.2 Motor Speed High Limit [Hz] or *parameter P 2.3.14 Max Output Frequency* sets the maximum output speed that the drive can provide.

7.9 Power Cable

7.9.1 Power Cable Considerations

When selecting power cables, consider:

- All wiring must comply with local and national regulations regarding cross-section and ambient temperature requirements.
- Drives are designed for use with 70 °C (158 °F) rated copper cables. Unless otherwise stated, the ambient temperature of the drive matches the cable rating.
- Aluminum conductors are not recommended. When using aluminum conductors, ensure that the conductor surface is clean and the oxidation is removed and sealed by a neutral acid-free grease before connecting the conductor. Retighten the terminal screw after 2 days due to the softness of aluminum. It is crucial to keep the connection a gas-tight joint, otherwise the aluminum surface oxidizes again.

- Cable lugs are required for the PE wire.
 - For MA01c–MA02c, recommended cable lug for PE wire is JST 8-4 (solderless terminals ring tongue).

For details on power connector sizing, see [4.4 Power Connectors](#). The dimensions apply to both solid and stranded cables.

7.9.2 Torque Requirements

Connections must be tightened with the correct torque, see the following table.

Table 54: Torque Requirements

Enclosure size	Mains and motor [Nm (in-lb)]	DC connection [Nm (in-lb)]	Brake [Nm (in-lb)]	Customer relay [Nm (in-lb)]	Grounding connection [Nm (in-lb)]
MA01c	0.7 (6.2)	0.7 (6.2)	–	0.5 (4.4)	1.5 (13.3)
MA02c	0.7 (6.2)	0.7 (6.2)	–	0.5 (4.4)	1.5 (13.3)
MA01a	0.7 (6.2)	Straight receptacles	–	0.5 (4.4)	1.5 (13.3)
MA02a	0.7 (6.2)	Straight receptacles	–	0.5 (4.4)	1.5 (13.3)
MA03a	0.7 (6.2)	Straight receptacles	–	0.5 (4.4)	1.5 (13.3)
MA04a	1.2 (10.6)	1.2 (10.6)	1.2 (10.6)	0.5 (4.4)	2.0 (17.7)
MA05a	1.2 (10.6)	1.2 (10.6)	1.2 (10.6)	0.5 (4.4)	2.0 (17.7)

7.10 Electrical Installation

7.10.1 Mains, Motor, and Grounding Connection

The mains, motor, and grounding connection for single-phase and 3-phase drives are shown in [Figure 46](#) and [Figure 47](#). Actual configurations vary with unit types and optional equipment.

NOTICE

In motors without phase insulation, paper, or other insulation reinforcement suitable for operation with voltage supply, use a sine-wave filter on the output of the drive.

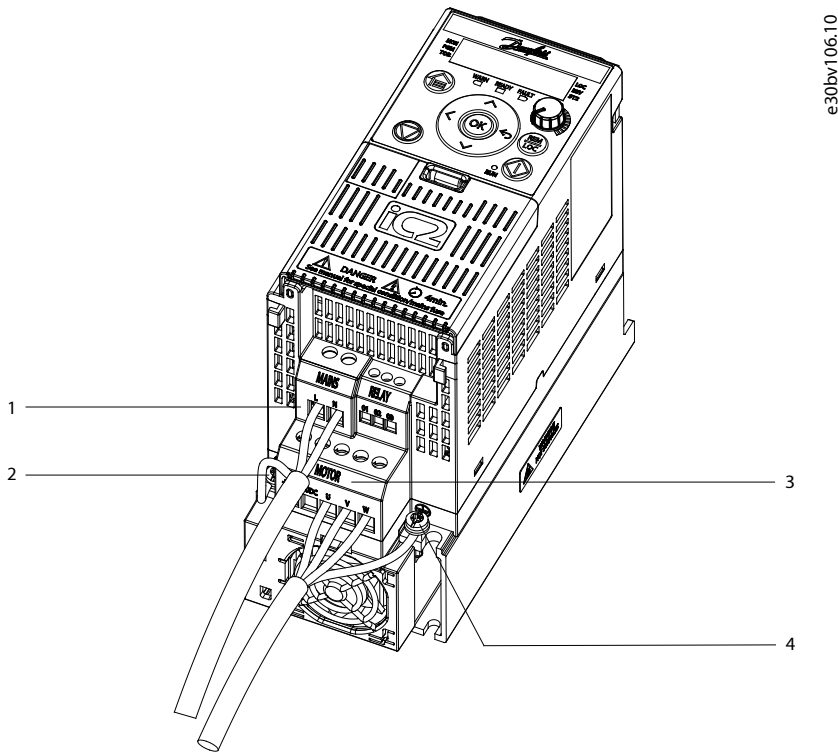

e30bv106.10

Figure 46: Mains, Motor, and Grounding Connection for Single-phase Units (Taking MA02c as an Example)

1	Mains	2	Grounding point A
3	Motor	4	Grounding point B

NOTICE

For MA01c and MA02c drives, grounding point A supports 10 mm² (7 AWG) cable via a cable shoe, the recommended cable shoe type is *JST copper tubular lug TUB-4*.

NOTICE

For MA01c and MA02c drives, decoupling plates are needed if 3 grounding terminals are used.

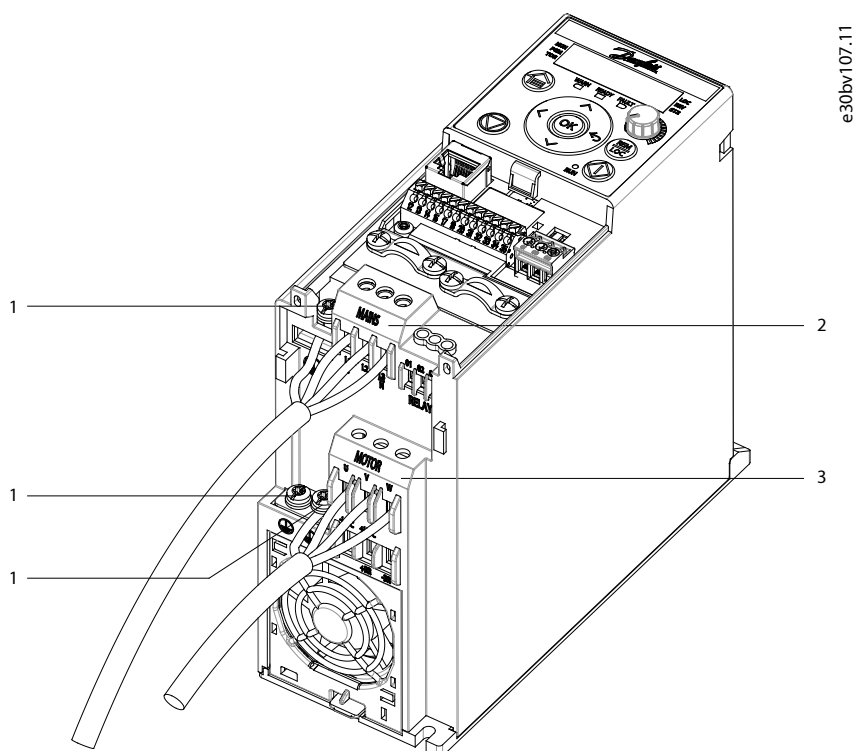

Figure 47: Mains, Motor, and Grounding Connection for 3-phase Units (Taking MA02a as an Example)

1	Grounding	2	Mains
3	Motor		

7.10.2 Connecting the Motor

⚠ WARNING



INDUCED VOLTAGE

Induced voltage from output motor cables that run together can charge equipment capacitors, even with the equipment turned off and locked out/tagged out. Failure to run output motor cables separately, or to use shielded cables, could result in death or serious injury.

- Run output motor cables separately or use shielded cables.
- Simultaneously lock out/tag out all the drives.

- Comply with local and national electrical codes for cable sizes. For maximum cable sizes, see [4.4 Power Connectors](#).
- Follow motor manufacturer wiring requirements.
- Motor wiring knockouts or access panels are provided at the base of IP21/Type 1 units.
- Do not wire a starting or pole-changing device (for example, Dahlander motor or slip ring induction motor) between the drive and the motor.

7.10.3 Connecting AC Mains

- Size the wiring based on the input current of the drive. For maximum wire sizes, see [4.4 Power Connectors](#).
- Comply with local and national electrical codes for cable sizes.
 1. Connect the AC input power cables to terminals N and L for single-phase units, or to terminals L1, L2, and L3 for 3-phase units as shown in [Figure 48](#) (see [7.10.1 Mains, Motor, and Grounding Connection](#) for more details).

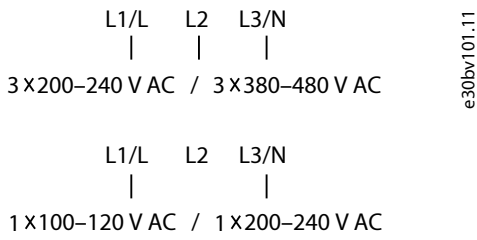

Figure 48: Single-phase and 3-phase Wire Connections

2. Depending on the configuration of the equipment, connect the input power to the mains input terminals or the input disconnect.
3. Ground the cable in accordance with the grounding instructions, see [7.4.2 Power Cables and Grounding](#).

7.10.4 Control Terminal Types

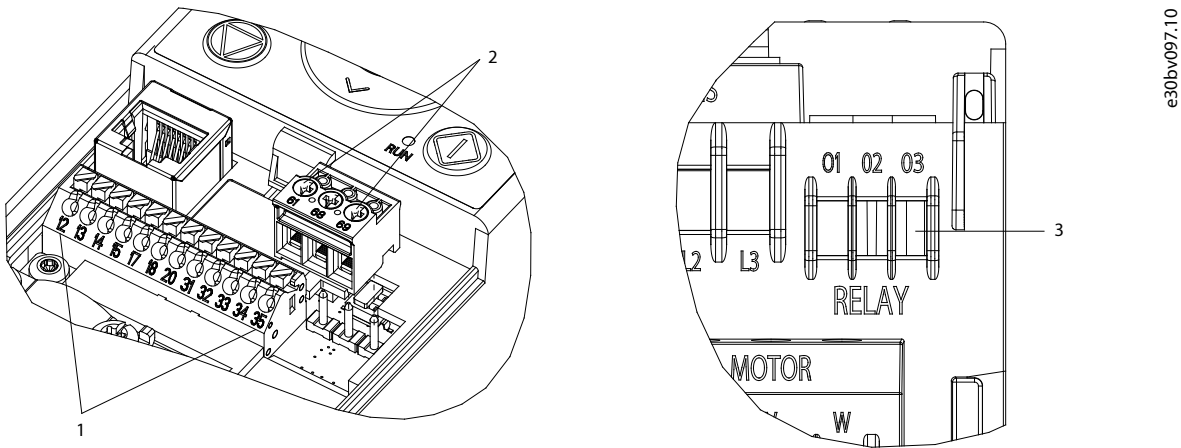

Figure 49: Control Terminal Numbers and Locations

1	Control I/O terminals	2	Serial communication
3	Relay		

Table 55: Terminal Descriptions

Terminal	Parameter	Default setting	Description
Digital I/O, pulse I/O			
12	–	+24 V DC	24 V DC supply voltage. Maximum output current is 100 mA.
13	<i>Parameter P 9.4.1.2 Terminal 13 Digital Input</i>	<i>[8] Start</i>	Digital input.
14	<i>Parameter P 9.4.1.3 Terminal 14 Digital Input</i>	<i>[10] Reversing</i>	Digital input.

Table 55: Terminal Descriptions (continued)

Terminal	Parameter	Default setting	Description
15	<i>Parameter P 9.4.1.4 Terminal 15 Digital Input</i>	<i>[1] Reset</i>	Selectable for either digital input, digital output, or pulse output. The default setting is digital input.
	<i>Parameter P 9.4.2.2 Terminal 15 Digital Output</i>	<i>[0] No Operation</i>	
	<i>Parameter P 9.4.5.1 Terminal 15 Pulse Output</i>	<i>[0] No Operation</i>	
17	<i>Parameter P 9.4.1.5 Terminal 17 Digital Input</i>	<i>[14] Jog</i>	Digital input.
18	<i>Parameter P 9.4.1.6 Terminal 18 Digital Input</i>	<i>[0] No Operation</i>	Digital input, can also be used for pulse input.
20	–	–	Common for digital and analog inputs.
Analog inputs/outputs			
31	<i>Parameter P 9.5.1.1 Terminal 31 Mode</i>	<i>[0] 0–20 mA</i>	Programmable analog output. The analog signal is 0–20 mA or 4–20 mA at a maximum of 500 Ω.
32	–	+10 V DC	10 V DC analog supply voltage. 25 mA maximum commonly used for potentiometer or thermistor.
33	<i>Parameter P 9.5.2.1 Terminal 33 Mode</i>	<i>[1] Voltage Mode</i>	Analog input. Selectable between voltage or current mode.
34	<i>Parameter P 9.5.3.1 Terminal 34 Mode</i>	<i>[1] Voltage Mode</i>	Analog input. Selectable between voltage or current mode.
35	–	–	Common for digital and analog inputs.
Serial communication			
61	–	–	Common for RS485 interface.
68 (+)	<i>Parameter group G 10.1 FC Port Settings</i>	–	RS485 interface. A switch is provided for termination resistance.
69 (-)	<i>Parameter group G 10.1 FC Port Settings</i>	–	
Relays			
01, 02, 03	<i>Parameter P 9.4.3.1 Function Relay</i>	<i>[9] Fault</i>	Form C relay output. These relays are in various locations depending on the drive configuration and size. Usable for AC or DC voltage and resistive or inductive loads.

7.10.5 Control Wire Sizes and Stripping Lengths

Connections are made by pushing solid wire into the connector. If flexible (multicore) wire is used, ferrules are recommended. When flexible wire is used without ferrules, the connector is pushed with a small screwdriver as shown in [Figure 50](#). The maximum size of the screwdriver is 3 mm.

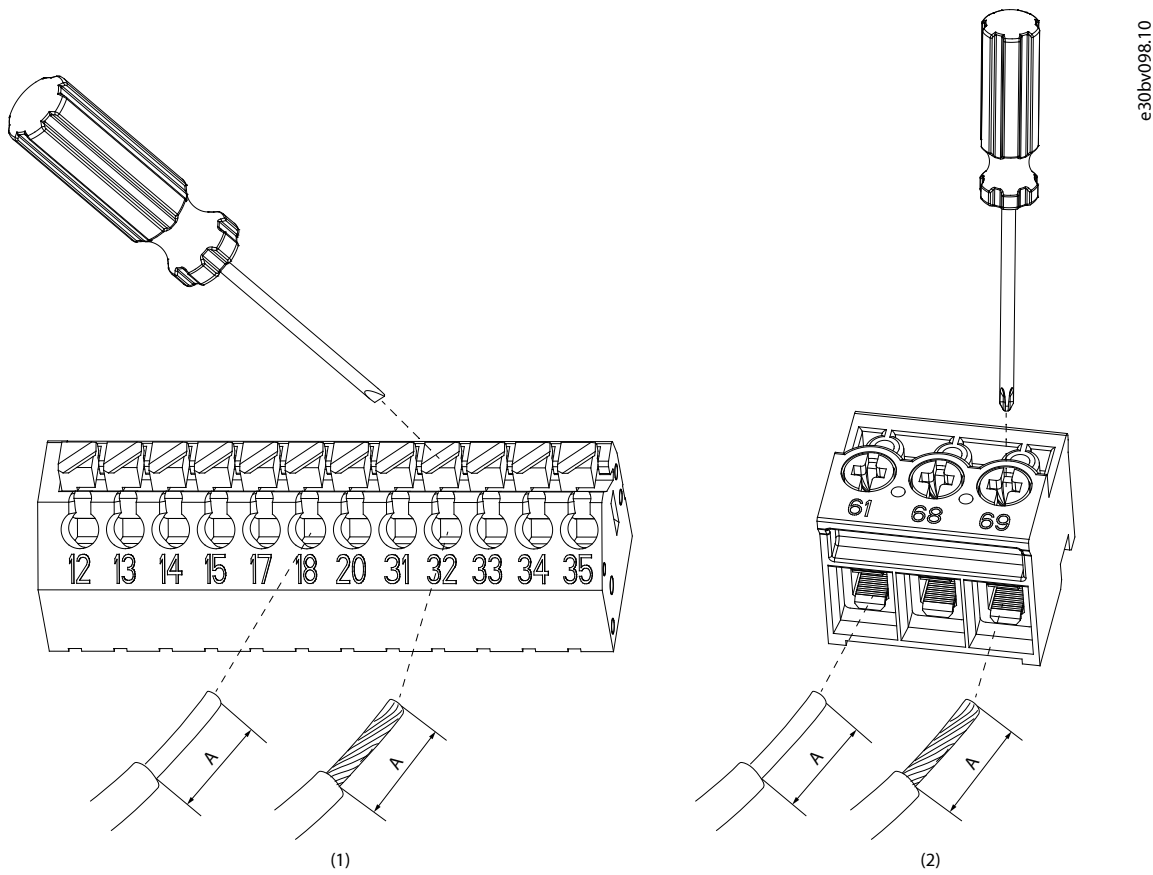

Figure 50: Inserting Wires into the Connector

1 I/O terminal	2 RS485 terminal
----------------	------------------

Table 56: Cable Sizing for I/O Terminal

Wire type	Cross-section [mm ² (AWG)]	Stripping length A [mm (in)]
Solid	0.2–1.5 (24–16)	8.5–9.5 (0.33–0.37)
Flexible with ferrule	0.2–1.5 (24–16)	8.5–9.5 (0.33–0.37)

Table 57: Cable Sizing for RS485 Terminal

Wire type	Cross-section [mm ² (AWG)]	Stripping length A [mm (in)]
Solid	0.25–1.5 (24–16)	5–6 (0.20–0.24)
Flexible with ferrule	0.25–1.5 (24–16)	5–6 (0.20–0.24)

7.10.6 Cable Shield Connection

The cable shield must be completely in contact with the EMC clamp on the EMC plate. Cable isolation must be removed and the cable shield exposed for the entire surface. Avoid pigtails.

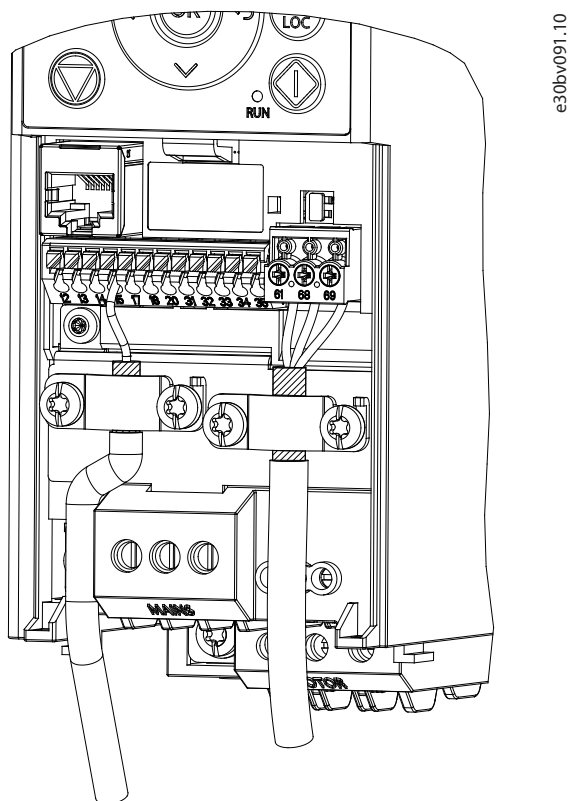

e30bv091.10

Figure 51: Correct Connection of the Cable Shield

The preferred method is to secure control and serial communication cables with shielding clamps provided at both ends to ensure the best possible high-frequency cable contact.

If the ground potential between the drive and the PLC is different, electric noise could disturb the entire system. Solve this problem by fitting an equalizing cable as close as possible to the control cable. Minimum cable cross-section: 16 mm² (6 AWG).

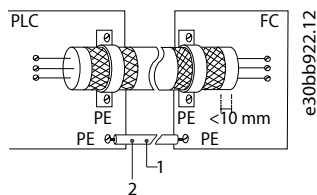

e30bb972.12

Figure 52: Shielding Clamps at Both Ends

- | | | | |
|---|------------------------------------|---|------------------|
| 1 | Minimum 16 mm ² (6 AWG) | 2 | Equalizing cable |
|---|------------------------------------|---|------------------|

With long control cables, ground loops may occur. To eliminate ground loops, connect the end of the shield to the ground with a 100 nF capacitor (keeping leads short).

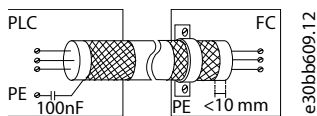

e30bb609.12

Figure 53: Connection with a 100 nF Capacitor

To avoid EMC noise on serial communication, terminal 61 is connected to ground via an internal RC link. Use twisted-pair cables to reduce interference between conductors. The recommended method is shown in [Figure 54](#).

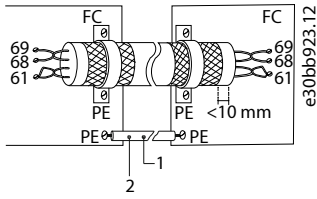

Figure 54: Twisted-pair Cables

1	Minimum 16 mm ² (6 AWG)	2	Equalizing cable
---	------------------------------------	---	------------------

Alternatively, the connection to terminal 61 can be omitted.

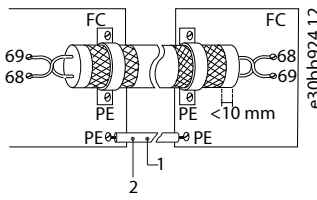

Figure 55: Twisted-pair Cables without Terminal 61

1	Minimum 16 mm ² (6 AWG)	2	Equalizing cable
---	------------------------------------	---	------------------

7.10.7 Load Sharing/Brake

Table 58: Connect Terminals

Load sharing	-UDC and +UDC/+BR
Brake	-BR and +UDC/+BR

- For MA01a, MA02a, and MA03a drives, wire with recommended connector (Ultra- Pod Fully Insulated FASTON Receptacles and Tabs, 521366-2, TE connectivity).
- For other enclosure sizes, mount the wires to the related terminal and tighten. For required maximum screwing torque, see the back of the terminal cover.

NOTICE

Voltage levels of up to 850 V DC may occur between terminals +UDC/+BR and -UDC. Not short-circuit protected.

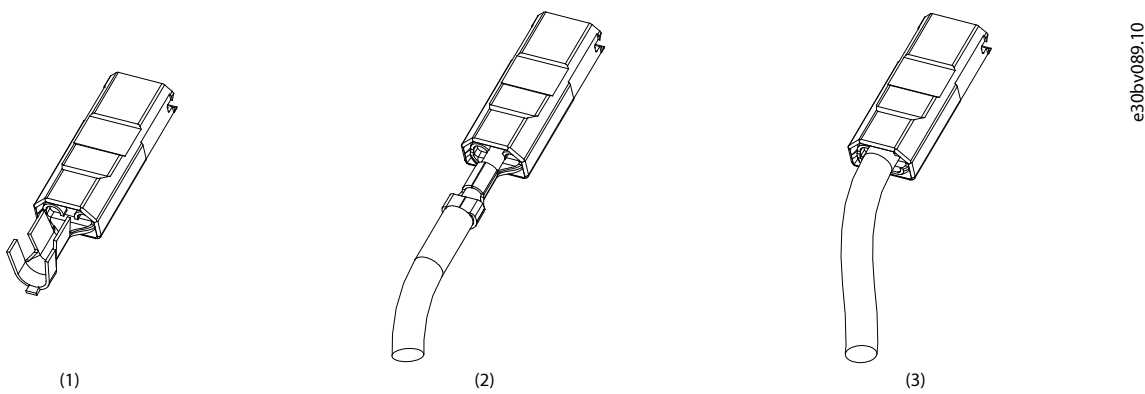

Figure 56: Wiring the Connector for Load Sharing and Brake

1	Connector	2	Wiring the connector
3	Wiring completed		

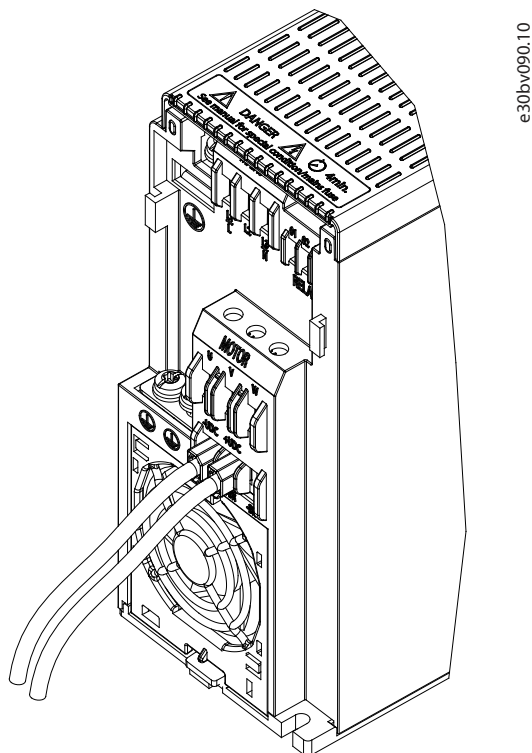

Figure 57: Connecting to Load Sharing and Brake

NOTICE

BRAKE FUNCTION OF MA02A

For MA02a, only 3x200–240 V and 3x380–480 V drives have brake function.

- Do not connect the brake cable to MA02a 1x200–240 V drives.

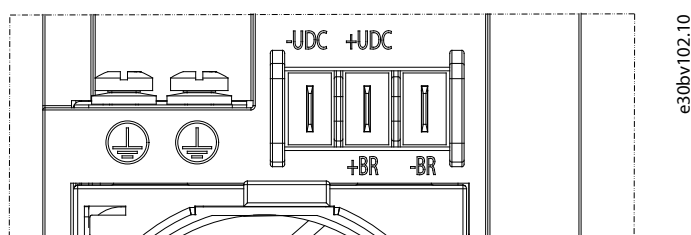

Figure 58: Brake Function of MA02a (3x380–480 V)

8 How to Order

8.1 Model Code

The configuration of the drive is reflected in the model code. The model code can be used to identify the specific drive configuration and its inbuilt features.

1	2	3	4	5	6	7	8	9	10	11	12	13	14	15	16	17	18	19	20	21	22	23	24	25	26	27	
i	C	2	-	3	0	F	A	3	N	0	4	-	0	1	A	2	E	2	0	F	0	+	A	C	B	C	
								1	N	0	2										F	2		A	C	X	X
																					F	4					

e30bv086.10

Figure 59: Model Code

Table 59: Example of a Final Model Code

Description	Position	Function
Product group	1–6	iC2-30
Product category	7–8	FA: Frequency converter, air-cooled
Product type	9–10	<ul style="list-style-type: none"> 3N: 3-phase power supply 1N: 1-phase power supply
Mains voltage	11–12	<ul style="list-style-type: none"> 01: 100–120 V AC 02: 200–240 V AC 04: 380–480 V AC
Current rating	14–17	01A2–46A2
Protection rating	18–20	E20: IP20/Open Type
EMC category	21–22	<ul style="list-style-type: none"> F0: C1 category (with integrated EMC filter) F2: C2 category (with integrated EMC filter) F4: C4 category (without integrated EMC filter)
Integrated brake chopper	Plus code	<ul style="list-style-type: none"> +ACBC: With integrated brake chopper +ACXX: Without integrated brake chopper

8.2 Ordering Accessories and Spare Parts

Table 60: Code Numbers for Ordering Accessories

Category	Part name	Code number
IP21/Type 1 conversion kits	IP21/Type 1 conversion kit, MA01c	132G0188
	IP21/Type 1 conversion kit, MA02c	132G0189
	IP21/Type 1 conversion kit, MA01a	132G0190
	IP21/Type 1 conversion kit, MA02a	132G0191
	IP21/Type 1 conversion kit, MA03a	132G0192

Table 60: Code Numbers for Ordering Accessories (continued)

Category	Part name	Code number
NEMA 1 conversion kits	NEMA 1 conversion kit, MA01c	132G0195
	NEMA 1 conversion kit, MA02c	132G0196
	NEMA 1 conversion kit, MA01a	132G0197
	NEMA 1 conversion kit, MA02a	132G0198
	NEMA 1 conversion kit, MA03a	132G0199
	NEMA 1 conversion kit, MA04a	132G0200
	NEMA 1 conversion kit, MA05a	132G0201
Decoupling plate mounting kits	Decoupling plate mounting kit, MA01c	132G0202
	Decoupling plate mounting kit, MA02c	132G0203
	Decoupling plate mounting kit, MA01a	132G0204
	Decoupling plate mounting kit, MA02/03a	132G0205
	Decoupling plate mounting kit, MA04/05a	132G0206
Connectors	Connector for common DC/brake resistor	132G0207
HMI and related accessories	Control panel 2.0 OP2	132G0234
	Surface mounting kit OA2	132G0235
	Flush mounting kit OA2	132G0236
	Control panel cable 1.5 m OA2	132G0237
	Control panel cable 3 m OA2	132G0238
Adapter	Quick Adapter USB-C/RJ45 OAX00	132G0326

Table 61: Code Numbers for Ordering Spare Parts

Category	Part name	Code number
Cooling fans	Cooling fan, MA02c	132G0215
	Cooling fan, MA01a	132G0216
	Cooling fan, MA02a	132G0217
	Cooling fan, MA03a	132G0218
	Cooling fan, MA04a	132G0219
	Cooling fan, MA05a	132G0220

Table 61: Code Numbers for Ordering Spare Parts (continued)

Category	Part name	Code number
Spare parts kits	Spare parts kit, MA01c	132G0221
	Spare parts kit, MA02c	132G0222
	Spare parts kit, MA01a	132G0223
	Spare parts kit, MA02a	132G0224
	Spare parts kit, MA03a	132G0225
	Spare parts kit, MA04a	132G0226
	Spare parts kit, MA05a	132G0227

8.3 Ordering Brake Resistors

8.3.1 Introduction

Danfoss offers a wide variety of different resistors that are specially designed for our drives. This section lists the code numbers for the brake resistors. The resistance of the brake resistor given by code number may be bigger than R_{rec} . In this case, the actual braking torque could be smaller than the highest braking torque which the drive can provide.

8.3.2 Ordering Brake Resistors 10%

Table 62: iC2-Micro Frequency Converters- Mains: 3x380–480 V AC, 10% Duty Cycle

Power rating	P_m (HO)	R_{min}	$R_{br. nom}$	R_{rec}	$P_{br. avg}$	Code number	Period	Cable cross-section ⁽¹⁾	Thermal relay	Maximum brake torque with resistor
3-phase 380–480 V	[kW (hp)]	[Ω]	[Ω]	[Ω]	[kW (hp)]	175Uxxxx	[s]	[mm ² (AWG)]	[A]	[%]
05A3	2.2 (3.0)	139	163.95	155	0.190 (0.255)	3008	120	1.5 (16)	0.9	131
07A2	3 (4.0)	100	118.86	112	0.262 (0.351)	3300	120	1.5 (16)	1.3	131
09A0	4 (5.0)	74	87.93	83	0.354 (0.475)	3335	120	1.5 (16)	1.9	128
12A0	5.5 (7.5)	54	63.33	60	0.492 (0.666)	3336	120	1.5 (16)	2.5	127
15A5	7.5 (10)	38	46.05	43	0.677 (0.894)	3337	120	1.5 (16)	3.3	132
23A0	11 (15)	27	32.99	31	0.945 (1.267)	3338	120	1.5 (16)	5.2	130
31A0	15 (20)	19	24.02	22	1.297 (1.739)	3339	120	1.5 (16)	6.7	129
37A0	18.5 (25)	16	19.36	18	1.610 (2.158)	3340	120	1.5 (16)	8.3	132
43A0	22 (30)	16	18.00	17	1.923 (2.578)	3357	120	1.5 (16)	10.1	128

1) All cabling must comply with national and local regulations on cable cross-sections and ambient temperature.

Table 63: iC2-Micro Frequency Converters- Mains: 3x200–240 V AC, 10% Duty Cycle

Power rating	P _m (HO)	R _{min}	R _{br. nom}	R _{rec}	P _{br avg}	Code number	Period	Cable cross-section ⁽¹⁾	Thermal relay	Maximum brake torque with resistor
3-phase 200–240 V	[kW (hp)]	[Ω]	[Ω]	[Ω]	[kW (hp)]	175Uxxxx	[s]	[mm ² (AWG)]	[A]	[%]
07A8	1.5 (2.0)	53	62.70	59	0.128 (0.172)	3026	120	1.5 (16)	1.6	143
11A0	2.2 (3.0)	35	42.06	39	0.190 (0.225)	3031	120	1.5 (16)	1.9	140
15A2	3.7 (5.0)	20	24.47	23	0.327 (0.439)	3326	120	1.5 (16)	3.5	145
24A2	5.5 (7.5)	14	17.28	16	0.463 (0.621)	3327	120	1.5 (16)	5.3	144
31A0	7.5 (10)	9	12.56	11	0.636 (0.853)	3328	120	1.5 (16)	6.8	145
46A2	11 (15)	7	8.49	8	0.942 (1.263)	3329	120	2.5 (14)	10.5	141

1) All cabling must comply with national and local regulations on cable cross-sections and ambient temperature.

8.3.3 Ordering Brake Resistors 40%

Table 64: iC2-Micro Frequency Converters - Mains: 3x380–480 V AC, 40% Duty Cycle

Power rating	P _m (HO)	R _{min}	R _{br. nom}	R _{rec}	P _{br avg}	Code number	Period	Cable cross-section	Thermal relay	Maximum brake torque with resistor
3-phase 380–480 V (T4)	[kW (hp)]	[Ω]	[Ω]	[Ω]	[kW (hp)]	175Uxxxx	[s]	[mm ² (AWG)]	[A]	[%]
05A3	2.2 (3.0)	139	163.95	155	0.807 (1.082)	3312	120	1.5 (16)	2.1	131
07A2	3 (4.0)	100	118.86	112	1.113 (1.491)	3313	120	1.5 (16)	2.7	131
09A0	4 (5.0)	74	87.93	83	1.504 (2.016)	3314	120	1.5 (16)	3.7	128
12A0	5.5 (7.5)	54	63.33	60	2.088 (2.799)	3315	120	1.5 (16)	5	127
15A5	7.5 (10)	38	46.05	43	2.872 (3.850)	3316	120	1.5 (16)	7.1	132
23A0	11 (15)	27	32.99	31	4.226 (5.665)	3236	120	2.5 (14)	11.5	130
31A0	15 (20)	19	24.02	22	5.804 (7.780)	3237	120	2.5 (14)	14.7	129
37A0	18.5 (25)	16	19.36	18	7.201 (9.653)	3238	120	4 (12)	19	132
43A0	22 (30)	16	18.00	17	8.604 (11.534)	3203	120	4 (12)	23	128

1) All cabling must comply with national and local regulations on cable cross-sections and ambient temperature.

Table 65: iC2-Micro Frequency Converters- Mains: 3x200–240 V AC, 40% Duty Cycle

Power rating	P_m (HO)	R_{min}	$R_{br. nom}$	R_{rec}	$P_{br avg}$	Code number	Period	Cable cross-section ⁽¹⁾	Thermal relay	Maximum brake torque with resistor
3-phase 200–240 V	[kW (hp)]	[Ω]	[Ω]	[Ω]	[kW (hp)]	175Uxxxx	[s]	[mm ² (AWG)]	[A]	[%]
07A8	1.5 (2.0)	53	62.70	59	0.541 (0.725)	3302	120	1.5 (16)	2.7	143
11A0	2.2 (3.0)	35	42.06	39	0.807 (1.082)	3303	120	1.5 (16)	4.2	140
15A2	3.7 (5.0)	20	24.47	23	1.386 (1.859)	3305	120	1.5 (16)	6.8	145
24A2	5.5 (7.5)	14	17.28	16	2.070 (2.776)	3306	120	1.5 (16)	10.4	144
31A0	7.5 (10)	9	12.56	11	2.847 (3.818)	3307	120	2.5 (14)	14.7	145
46A2	11 (15)	7	8.49	8	4.215 (5.652)	3176	120	4 (12)	23	141

1) All cabling must comply with national and local regulations on cable cross-sections and ambient temperature.

Danfoss A/S
Ulsnaes 1
DK-6300 Graasten
drives.danfoss.com

.....
Any information, including, but not limited to information on selection of product, its application or use, product design, weight, dimensions, capacity or any other technical data in product manuals, catalog descriptions, advertisements, etc. and whether made available in writing, orally, electronically, online or via download, shall be considered informative, and is only binding if and to the extent, explicit reference is made in a quotation or order confirmation. Danfoss cannot accept any responsibility for possible errors in catalogs, brochures, videos and other material. Danfoss reserves the right to alter its products without notice. This also applies to products ordered but not delivered provided that such alterations can be made without changes to form, fit or function of the product. All trademarks in this material are property of Danfoss A/S or Danfoss group companies. Danfoss and the Danfoss logo are trademarks of Danfoss A/S. All rights reserved.
.....

M00352

