

ENGINEERING
TOMORROW



Application Guide

iC7 Series DC/DC Converter

iC7-Hybrid

OPEN UP A NEW DIMENSION OF INTELLIGENCE

PROGRAMMABILITY
PREDICTIVE MAINTENANCE
DATA SECURITY
CONNECTIVITY
APPLICATION PERFORMANCE
POWER DENSITY



www.danfoss.com |



Contents

1	INTRODUCTION TO THE APPLICATION GUIDE	1
1.1	Version History	1
1.2	Purpose of this Application Guide	1
1.3	Intended Audience	1
1.4	Additional Resources	1
1.5	Safety Symbols	1
2	INTRODUCTION TO IC7-HYBRID	2
2.1	Overview	2
3	DC/DC APPLICATION SOFTWARE OVERVIEW	3
3.1	Introduction to DC/DC Application Software	3
3.2	Supported fieldbus protocols based on product configuration	4
3.3	Security Features	4
3.4	DC/DC Converter Control Mode Overview	5
3.4.1	DC/DC Converter Control Modes	5
3.4.2	DC Source Current Control and Limit Feature	6
3.4.3	DC Source Voltage Control	7
3.4.4	Sensorless Source Voltage Control with IR Compensation	7
3.4.5	DC-link Voltage Control	8
3.4.6	DC-link Current Control	8
3.5	Control Mode Prioritization	11
3.6	DC Source Voltage Limit Control	11
3.7	DC-link Overvoltage and Undervoltage Control	11
3.8	Paralleling DC/DC Converters	12
3.8.1	Paralleling Using Droop Control	13
3.8.2	Droop Control Calculation	13
3.9	DC Source Supervision	15
3.9.1	DC Source Current Supervision	15
3.9.2	DC Source Voltage Supervision	15
4	CONTROL PLACES	17
4.1	Overview of Control Places	17
4.2	Control place selection	17
4.3	I/O Control	19
4.4	Fieldbus Control	20
4.4.1	Fieldbus Control Word and Bit Descriptions	20
4.4.2	Fieldbus Status Word and Bit Descriptions	22
4.4.3	DC/DC Control Word and Bit Descriptions	23
4.4.4	Custom Status Word and Bit Descriptions	24

4.5	Local Control.....	24
4.6	PC Control.....	24
5	QUICK START UP & CONFIGURATION EXAMPLES	25
5.1	Configuring an energy storage application.....	25
5.2	Configuring the Operating Mode and DC-Link Limit Controls	25
5.3	Configuring the DC-Link Current Control.....	27
6	MENU STRUCTURE.....	28
6.1	Understanding Application Menu Structure	28
6.1.1	Application Menu Structure.....	28
6.1.2	Understanding Data Types.....	29
6.2	Monitoring.....	30
6.2.1	Basic Monitoring.....	30
6.2.2	Control Mode and Reference Monitoring.....	30
6.2.3	Limit Monitoring.....	31
6.2.4	Control Place Monitoring.....	31
6.2.5	DC Source Monitoring	31
6.2.6	DC-link Monitoring	31
6.2.7	Converter Control Monitoring.....	32
6.2.8	Protection Monitoring	32
6.2.9	Custom Status Word Monitoring.....	32
6.2.10	Power Unit Monitoring	33
6.2.11	Cooling Fan Monitoring	33
6.2.12	Fieldbus Process Data Status	33
6.2.13	I/O and Relay Status.....	34
6.2.14	Temperature Measurement Status	34
6.2.15	Voltage Measurement.....	34
6.3	Parameters.....	34
6.3.1	Basic Parameters.....	34
6.3.2	Control Mode and References	34
6.3.3	Limits	36
6.3.4	Digital and Analog Inputs	38
6.3.5	Digital and Analog Outputs	38
6.3.6	Start and Stop Settings.....	40
6.3.7	Control Places	41
6.3.8	Converter Control.....	41
6.3.9	Protections and Responses	43
6.4	Maintenance & Service	47
6.4.1	Software Information	47
6.4.2	Events.....	47

6.4.3	Operational Counters.....	47
6.5	Customization	47
6.5.1	Basic Settings.....	47
6.5.2	Control Panel	47
6.5.3	Custom Status Word.....	49
6.6	Option Board Settings	49
6.6.1	I/O and Relay.....	49
6.6.2	Temperature Measurement	51
6.6.3	Voltage Measurement.....	53
6.7	Connectivity Integrated Communication.....	54
6.7.1	Communication Interfaces	54
7	PARAMETER DESCRIPTIONS.....	56
7.1	How to read Parameter Descriptions.....	56
7.2	Monitoring (Menu Index 1)	56
7.2.1	Basic Monitoring (Menu Index 1.1).....	56
7.2.2	Control Mode and Reference Monitoring (Menu Index 1.2).....	65
7.2.3	Limit Monitoring (Menu Index 1.3).....	66
7.2.4	Control Place Monitoring.....	67
7.2.5	DC Source Monitoring (Menu Index 1.6)	67
7.2.6	DC-Link Monitoring (Menu Index 1.7)	67
7.2.7	Converter Control Monitoring (Menu Index 1.8).....	68
7.2.8	Protection Monitoring (Menu Index 1.9)	68
7.2.9	Custom Status Word Monitoring (Menu Index 1.10)	69
7.2.10	Power Unit Monitoring (Menu Index 1.11)	69
7.2.11	Cooling Fan Monitoring (Menu Index 1.12).....	70
7.2.12	Fieldbus Process Data Status	70
7.3	Parameters (Menu Index 2)	73
7.3.1	Basic Parameters (Menu Index 2.1).....	73
P 2.1.1	DC Source Nominal Voltage No. 2945.....	73
P 2.1.2	DC Source Nominal Current No. 2946.....	73
P 2.1.3	DC-link Nominal Voltage No. 2834.....	73
P 2.1.4	Unit Voltage Class No. 2832	73
P 2.1.5	Overload Mode No. 2833	74
P 2.1.6	Current/Power Positive Direction No. 2947	74
7.3.2	Control Mode and References (Menu Index 2.2).....	76
7.3.3	DC Source Current Reference (Menu Index 2.2.3).....	77
7.3.4	DC Source Power Reference (Menu Index 2.2.4).....	78
7.3.5	DC-link Voltage Reference (Menu Index 2.2.5).....	79
7.3.6	DC-link Current Reference (Menu Index 2.2.6)	80

7.3.7	Limits (Menu Index 2.3).....	81
7.3.8	Digital and Analog Inputs (Menu Index 2.4).....	86
7.3.9	Digital and Analog Outputs (Menu Index 2.5).....	87
7.3.10	Digital and Analog Outputs (Menu Index 2.5).....	87
7.3.11	Start and Stop Settings (Menu Index 2.6).....	91
7.3.12	Control Places (Menu Index 2.7).....	92
7.3.13	Converter Control (Menu Index 2.8).....	96
7.3.14	Protections and Responses (Menu Index 2.9).....	99
7.4	Maintenance & Service (Menu Index 3).....	112
7.4.1	Software Information (Menu Index 3.1).....	112
7.4.2	Events (Menu Index 3.2).....	112
7.4.3	Operational Counters (Menu Index 3.3).....	113
7.4.4	Backup & Restore (Menu Index 3.4).....	114
7.5	Customization (Menu Index 5).....	114
7.5.1	Basic Settings (Menu Index 5.1).....	114
7.5.2	Control Panel (Menu Index 5.2).....	114
7.5.3	Custom Status Word (Menu Index 5.3).....	116
7.6	Option Settings (Menu Index 9).....	118
7.6.1	I/O And Relay Status (Menu Index 9.3).....	118
7.6.2	Digital Inputs/Outputs (Menu Index 9.4).....	119
7.6.3	Analog Inputs/Outputs (Menu Index 9.5).....	121
7.6.4	Temperature Measurement.....	123
7.7	Connectivity.....	129
7.7.1	Integrated Communication.....	129
8	MYDRIVE® INSIGHT.....	133
8.1	Introduction to MyDrive® Insight.....	133
8.2	Getting Started with MyDrive Insight.....	134
8.3	Datalogger.....	135
9	TROUBLESHOOTING.....	139
9.1	Viewing Warnings.....	139
9.2	Viewing and Resetting Faults.....	139
9.3	Reading the Event Summary Table.....	140
9.3.1	Group number and number (columns 1–2).....	140
9.3.2	Display name and description (columns 3–4).....	140
9.3.3	Type of event (columns 5–8).....	140
9.3.4	Action of the converter (column 9).....	140
9.4	Events Summary for DC/DC Converter Application Software.....	140
9.5	Troubleshooting of Events.....	160
9.5.1	Event Type, 0x2130-4356 (8496–4356).....	160

9.5.2	Event Type, 0x2130-4370 (8496–4370)	160
9.5.3	Event Type, 0x2311-4097 (8977–4097)	160
9.5.4	Event Type, 0x2311-4369 (8977–4369)	160
9.5.5	Event Type, 0x3211-4144 (12817–4144)	161
9.5.6	Event Type, 0x3211-4144 (12817–4144)	162
9.5.7	Event Type, 0x3221-4146 (12833–4146)	162
9.5.8	Event Type, 0x4210-4103 (16912–4103)	162
9.5.9	Event Type, 0x4210-4104 (16912–4104)	163
9.5.10	Event Type, 0x4210-4110 (16912–4110)	163
9.5.11	Event Type, 0x4210-4125 (16912–4125)	163
9.5.12	Event Type, 0x7500-5141 (29952–5142)	163
9.5.13	Event Type, 0x7500-5142 (29952–5142)	164
9.5.14	Event Type, 0x7580-5120 (30080–5120)	164
9.5.15	Event Type, 0x7580-5121 (30080–5121)	164
9.5.16	Event Type, 0xFF03-5123 (65283–5123)	164
9.5.17	Event Type, 0xFF03-5124 (65283–5124)	165
9.5.18	Event Type, 0xFF09-5130 (65289–5130)	165
9.5.19	Event Type, 0x4210-4105 (16912–4105)	166
9.5.20	Event Type, 0x4210-5143 (16912–5143)	166
9.5.21	Event Type, 0x4210-5144 (16912–5144)	166
9.5.22	Event Type, 0x4210-5145 (16912–5145)	166

1 Introduction to the Application Guide

1.1 Version History

This guide is regularly reviewed and updated. All suggestions for improvement are welcome. The original language of this guide is in English.

Version	Remarks	Software Version
AB368051518886en-000201	General release 2	Application software version 5.1.0 Firmware version 5.17.0
AB368051518886en-000101	General release	Application software version 5.0.1 Firmware version 5.6.6

1.2 Purpose of this Application Guide

This application guide provides information on operating the DC/DC Converter application of the iC7 series. The application guide provides an overview of parameters and value ranges for operating the converter.

In addition to converter parameters, information on the various user interfaces to configure converter parameters, configuration examples with recommended parameter settings and troubleshooting steps are included in the application guide.

1.3 Intended Audience

The intended audience of the application guide is trained personnel, automation engineers, and configurators with experience in operating with parameters and with basic knowledge of AC drives.

1.4 Additional Resources

Additional resources are available with related information.

The Design Guide provides information about the capability and functionality to design power conversion systems with the Danfoss iC7 series. The Safety Guide provides important safety information related to iC7 series products. The Installation Guide covers the mechanical and electrical installation of the converters. Fieldbus operating instructions are available in the iC7 series Modbus TCP Operating Guide and iC7-Hybrid PROFINET Operating Guide.

1.5 Safety Symbols

The following symbols are used in this manual:



DANGER

INDICATES A HAZARDOUS SITUATION WHEN NOT AVOIDED, RESULTS IN DEATH OR SERIOUS INJURY.



WARNING

INDICATES A HAZARDOUS SITUATION WHEN NOT AVOIDED, COULD RESULT IN DEATH OR SERIOUS INJURY.



CAUTION

INDICATES A HAZARDOUS SITUATION WHEN NOT AVOIDED, COULD RESULT IN MINOR OR MODERATE INJURY.

NOTICE

INDICATES INFORMATION CONSIDERED IMPORTANT, BUT NOT HAZARD-RELATED (FOR EXAMPLE, MESSAGES RELATING TO PROPERTY DAMAGE).

2 Introduction to iC7-Hybrid

2.1 Overview

iC7-Hybrid is an enabler in electrification and hybridization applications. iC7-Hybrid covers all power conversion needs in low voltage AC and DC grid systems. iC7-Hybrid can be used to integrate diverse energy sources and energy storage to a utility grid, microgrid, or DC distribution. Some of the typical applications include:

- peak shaving
- time shifting
- backup power
- grid forming
- power quality
- marine shore supply

The following software applications are available in iC7-Hybrid:

- **Grid Converter:** Grid Converter is a dedicated power converter for grid forming, advanced grid control, and bi-directional AC/DC power conversion. Grid Converter is an ideal inverter solution for smart grid applications such as micro grid forming, AC coupled energy storage, shaft generator, and other flexible AC/DC or AC/AC power conversion applications.
- **DC/DC Converter:** The DC/DC Converter is a bi-directional power converter, enabling interconnection of two direct current (DC) systems having different voltage levels. Some of the benefits of the DC/DC converter are a wide source voltage range and the possibility for accurate current, voltage, or power control. The DC/DC converter overcomes the mismatches between operating voltage ranges of the energy source and the system DC voltage and enables the flexible combining of different power source technologies in one system.
- **Generator:** Generator is a multipurpose inverter targeted for the power generation and advanced multi-purposes use cases in marine vessels. It can be used to control shaft generators, auxiliary generators and motors in vessels, as well as shore connection to the electric grid at harbor. The Generator application provides the interface between variable speed AC power generation or motor and the DC bus of the system. The same physical hardware can be used for motor/generator control as well as the on-board shore connection.

Table 1: iC7-Hybrid Application Software Compatibility

Product	Application Software	Hardware Compatibility
iC7-Hybrid	Grid Converter	Liquid-cooled System Modules
	DC/DC Converter	Liquid-cooled System Modules
	Generator	Liquid-cooled System Modules

Danfoss offers MyDrive Virtual power converter model for system simulation, which includes full functionality of the power conversion control and the application layer. A hardware in the loop (HIL) simulation setup of the iC7 Series controller is also available for real time simulation purposes, such as PLC integration testing.

3 DC/DC Application Software Overview

3.1 Introduction to DC/DC Application Software

DC/DC Converter is a bi-directional power converter that enables the interconnection of two direct current (DC) systems with different voltage levels. The benefits of the DC/DC Converter include a wide source voltage range and the possibility for accurate current, voltage, or power control. The DC/DC Converter can overcome mismatches between operating voltage ranges of the energy source and the system DC voltage, which enables the flexible combination of different power source technologies in one system.

As an example, DC/DC Converter connects batteries, supercapacitor, or fuel cells to a DC distribution grid or DC-bus of a converter system. Batteries and fuel cells are used for long term energy supply. Supercapacitors are used when high short-term power is needed, and the energy requirement is limited. In this scenario, battery energy storage can be used for complete electric operation and peak shaving in hybrid systems to save energy. A combination of energy storage and peak shaving applications are used in modern marine vessels which transit to complete electric maneuvering near harbor areas to reduce local emissions. Peak shaving capacity is used in hybrid maneuvering mode to save fuel and to reduce emissions by smoothing the load variations of the gensets, as illustrated in Fig 1. Backup energy storage can be connected directly to the DC-bus of an important system instead of feeding the whole grid with an AC coupled UPS system. This way the energy storage is powering only the critical process, thus downsizing the required energy storage.

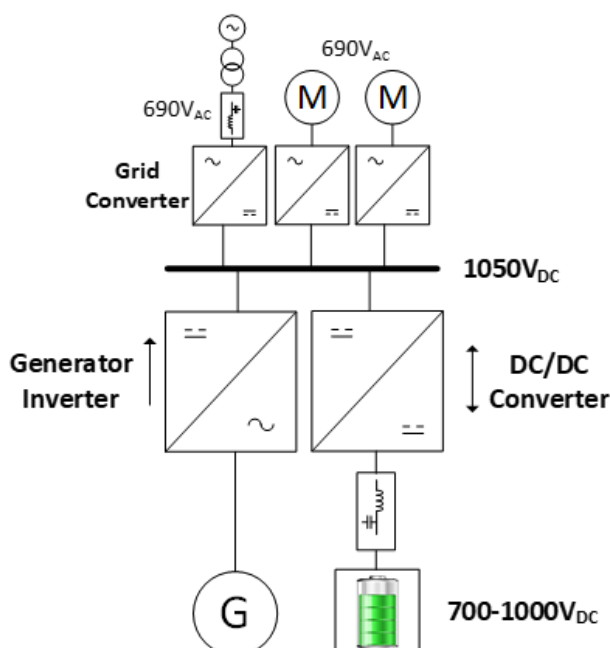

Illustration 1: Hybrid system with DC/DC Converter

DC/DC Converter can also be used as an adjustable DC voltage or current source and sink for any application, from test bench to a DC grid. DC/DC Converter can boost the DC voltage from a lower voltage source to a higher DC-link voltage, or step down the voltage of the DC link to feed the source or load. Energy transfer from low to high voltage is facilitated by using inductors as a temporary energy storage (boost inductors).

A three-phase inverter bridge is connected as illustrated in the following Illustration 2. It is known as a common source configuration. Three phases are interleaved with a 120-degree phase shift, resulting in partial cancellation of the triangular wave-shaped ripple current and effectively tripling the switching frequency.

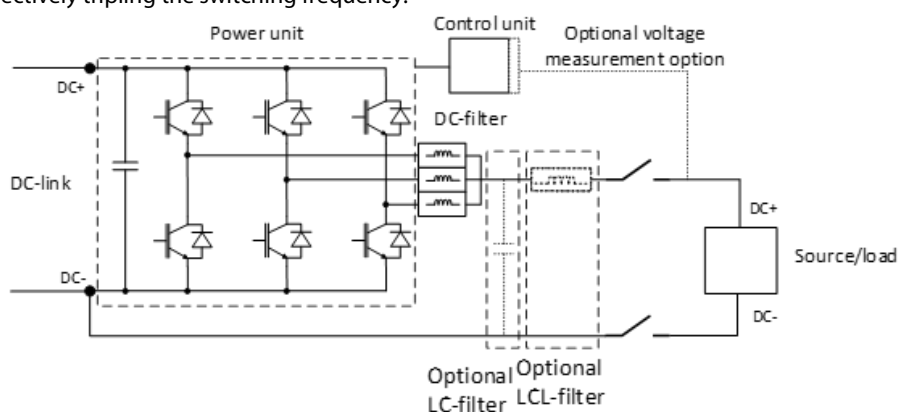

Illustration 2: DC/DC Converter connected to a load

DC/DC Converter can control either DC-link voltage, DC source voltage, DC source current, or DC-link current. Smooth transition between all four control modes is possible during operation (run state). In addition to the control modes, it is possible to include supplementary voltage limiting controllers and current limits, which can be enabled or disabled when required.

3.2 Supported fieldbus protocols based on product configuration

Table 2: Fieldbus Protocols

Fieldbus Protocol	Availability
MODBUS TCP	Embedded protocol
PROFINET	Embedded protocol but requires license to activate. Field upgrade is not supported in first release.

Fieldbus operating instructions are available in the iC7 series Modbus TCP Operating Guide and iC7-Hybrid PROFINET Operating Guide.

3.3 Security Features

The application software provides the following cybersecurity features:

- Signed and encrypted firmware.
- Secure firmware updates.
- User account and permission management.
- License verification.
- Secure protocol for all communication interfaces.
- Protection while remotely accessing the converter.
- Prevent code execution via interfaces.
- Firewall to protect the network from unauthorized access. Unused ports, interfaces, and service are disabled.

3.4 DC/DC Converter Control Mode Overview

3.4.1 DC/DC Converter Control Modes

The following table illustrates the different control modes used in DC/DC Converter, references, and limit control priority:

Table 3: Control Mode, References, and Limit Control Priority

Mode	References	Description
Source Voltage Control	Source voltage reference	Normal Operation: <ul style="list-style-type: none"> • Primary control objective is to regulate source voltage. • Power is determined by DC source/load. • Parallel converters can share load by drooping.
	Source current limit for DC-link overvoltage and undervoltage limit	Operation in Limit Control: <ul style="list-style-type: none"> • Primary limit controller objective to limit source current. • Secondary limit controller objective to limit DC-link voltage.
Source Current Control	Source current reference	Normal Operation: <ul style="list-style-type: none"> • Primary control is the objective to regulate source current. • Power is determined by DC source side load. Parallel converters follow their own current references (no drooping needed).
	Minimum and Maximum Source voltage limits Overvoltage and undervoltage DC-link limits	Operation in Limit Control: <ul style="list-style-type: none"> • Primary limit controller objective to limit source voltage. • Secondary limit controller objective to limit DC-link voltage.
DC-link Voltage Control	DC-link voltage reference	Normal Operation: <ul style="list-style-type: none"> • Power is determined by DC-link load. Converters can share load by drooping.
	Source current limit Minimum and maximum Source voltage limits	Operation in Limit Control: <ul style="list-style-type: none"> • Primary control is Source current limit controller. • Secondary control is Source voltage limit controller.
DC-link Current Control	DC-link Current reference Overvoltage and undervoltage DC-link limits	Normal Operation: <ul style="list-style-type: none"> • Primary objective is to regulate DC-link current. • Power is determined by the load on the DC-link. • Parallel converters follow their own current references (no drooping is needed)

DC/DC Converter control is based on a cascaded control structure that has fast closed-loop current control as an inner control loop and slower voltage control as an outer control loop. The DC-link voltage is controlled in closed loop. Source voltage control operates in sensorless mode (open loop) without source voltage feedback.

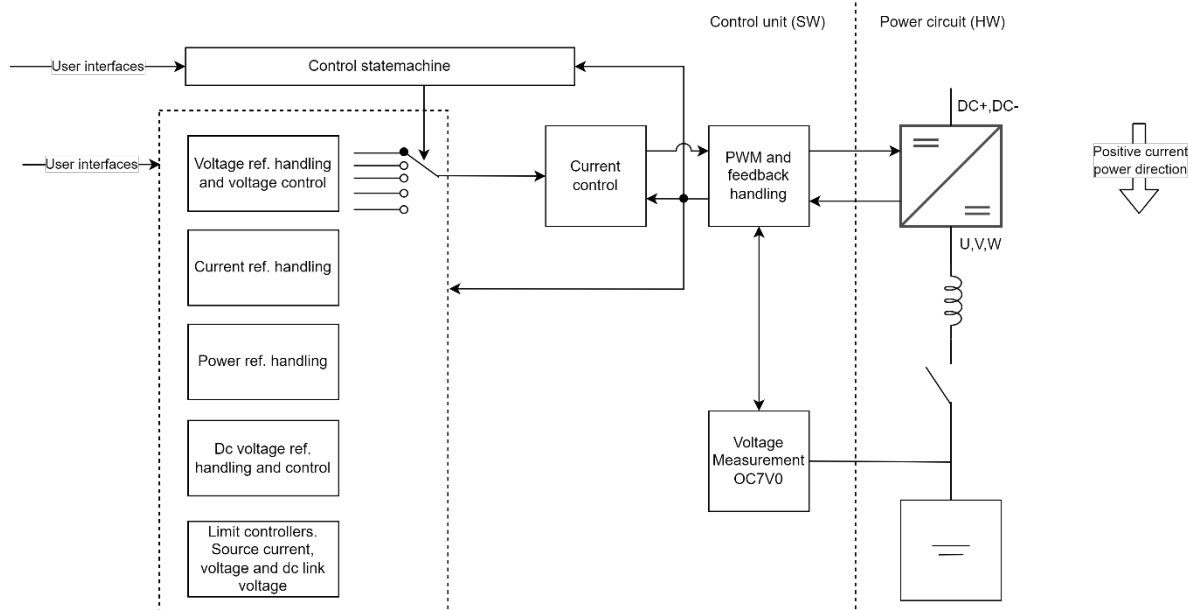

Illustration 3: DC/DC Converter Control

Please note that closed-loop operation, where the source voltage is measured using the Voltage measurement option, is not supported in the software version covered by this application guide.

The positive current direction is by default from the DC link towards the DC source. So, in a battery application, a positive current limit means a charging current limit by default.

Moreover, auxiliary protection features such as filter temperature monitoring and cooling unit supervision are available. The application software has flexible interfaces towards the secondary control system including a configurable fieldbus interface and customizable I/O interfaces, and human-machine interfaces (MyDrive Insight and a control panel).

A power and energy management system (PMS, EMS) is needed on the system level since the DC/DC Converter application software only provides functions to implement the power conversion control and limitations.

If batteries are used with DC/DC Converter, a battery management system (BMS) is mandatory due to safety considerations.

The MyDrive Insight Logic/Sequence customizer allows the implementing of additional functionality to the application software run by the control unit (not supported in software version covered by this application guide).

3.4.2 DC Source Current Control and Limit Feature

3.4.2.1 DC Source Current Control

The DC/DC Converter follows the current reference in the source current control mode. The mode is activated with parameter Operation Mode (No. 2504) and the current reference is set either by using a parameter or through fieldbus process data.

The reference is specified as a percentage value based on the nominal source current in Amperes. The source current reference is limited to the positive and negative source current limits, which can be set independently, and to the unsigned current limit which limits both current directions.

Increase in limit value settings is updated with ramp transitions. The final reference is pre-filtered with a low pass filter, the time constant of which is given in seconds before the reference is passed to the current controller. The current controller can be tuned to optimize the response. The current controller tuning parameters are given in percentages out of internal default values.

3.4.2.2 Current Limit

Current control and limits are active in all operation modes and cannot be disabled. Hence, the current limits are always applied on the final current reference provided to the current controller. The maximum values of the limits are hardware dependent, and affected by the cooling method, for example. Moreover, limits can be reduced by automatic derating functions, if those are selected. The Limit Control Status Word (No. 9080) monitoring parameter shows the activation of the current limit.

3.4.2.3 Power Limit

Charging (positive direction by default) and discharging (negative direction by default) power limits can be specified. The power limits are converted internally into currents and affect the current limits. If the actual power exceeds the limit, the current and power are limited. The Limit Control Status Word monitoring parameter shows the activation of the power limit.

3.4.3 DC Source Voltage Control

Source voltage control mode is activated using parameter Operation Mode. The converter regulates the source voltage at the voltage reference specified.

The reference is specified as percentage value based on the nominal source voltage defined in Volts. The reference source can be selected between parameter and fieldbus process data. The source voltage reference is limited between minimum and maximum values given in percentages based on the nominal source voltage.

Low-pass pre-filtering can be applied to the reference to smoothen the startup and reduce current spikes during substantial changes of reference value. The time constant of the filter is given in seconds. The final reference is provided to the source voltage controller.

The dynamic behavior of the source voltage controller can be tuned with controller parameters given in percentages of the internal default values. The converter is equipped with voltage sensors which enable a smooth start, even without the voltage measurement OC7V0 option.

The droop control function of the source voltage control is used to ensure load sharing between parallel-connected converters with individual control units. The droop gain parameter defines the percentage of the voltage reference change as a function of the percentage of the source current. When the same droop curve is used in parallel converters, the load is shared proportional to the converter ratings.

NOTICE

The defined current limits are applied to the final current reference to prevent overloading the converter and the DC source.

3.4.4 Sensorless Source Voltage Control with IR Compensation

When external source voltage measurement OC7V0 option is not available, the converter operates in sensorless voltage control mode and uses estimation of the source voltage in the control. The control accuracy is improved using iR compensation reducing the voltage estimation error caused by resistive voltage losses along the current path to the voltage source terminals, and voltage losses across the semiconductors. The resistive loss compensation is tuned using the filter resistance parameter.

3.4.5 DC-link Voltage Control

In the DC-link voltage control operation mode, DC/DC Converter adjusts the source current to maintain the DC-link voltage at the desired level. The voltage reference is specified as a percentage of the system nominal DC-link voltage, which can be controlled via parameter. The reference source can be set with a parameter using the fieldbus, or analog input.

The reference rate of change is limited by a ramp function and a reference low pass filter. The final reference is provided to the DC-link voltage controller. The dynamic behavior of the controller can be tuned with controller parameters specified in percentages based on the default values.

Droop control function is available for DC-link voltage control. Defined current limits are applied on the final current reference to prevent overloading of the converter and the DC source.

3.4.6 DC-link Current Control

In DC-link current control mode, the converter uses the DC current reference to control current. The DC-link current reference is given as percentage of the nominal DC-link current.

The configurable current limits are applied to the final current references. DC-link current control mode also allows the definition of a droop curve where the DC-link current will droop based on the function of DC-link voltage. The droop curve is added to the DC-link current reference, which is set by using either parameter or Fieldbus process data.

3.4.6.1 DC-link Current Control with customizable droop curve

DC-link current control mode also allows the definition of a droop curve where the DC-link current will droop based on the function of DC-link voltage. The droop curve is added to the DC-link current reference, which is set by using either parameter DC Current Reference % or Fieldbus process data.

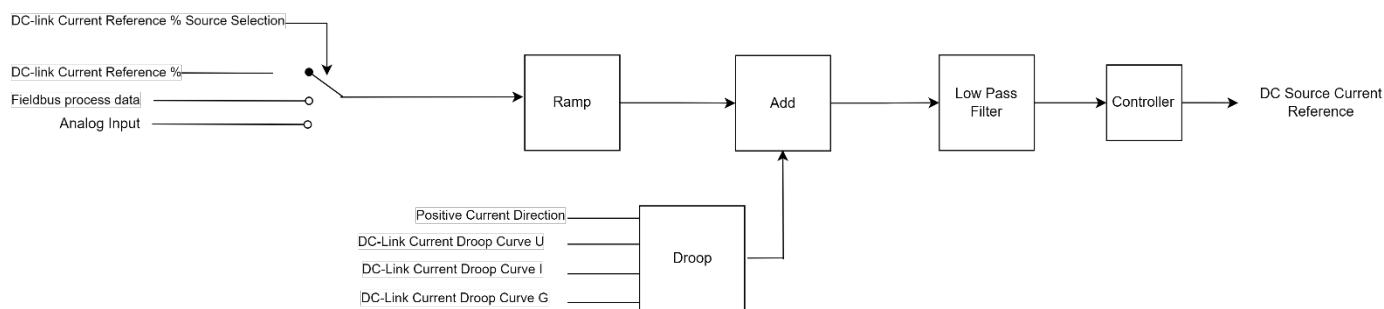

Illustration 4: DC-link current control

DC-link Current droop curve can be controlled using the following parameters:

- DC-link Current Droop Curve U (No. 5302)
- DC-link Current Droop Curve I (No. 5301)
- DC-link Current Droop Curve G (No. 5300)

All the above parameters are arrays with 4 points each, that define the droop curve configuration. These 4 points have been defined as follows:

- U1, U2, U3, and U4 for DC-link Current Droop Curve U
- I1, I2, I3, and I4 for DC-link Current Droop Curve I
- G1, G2, G3, and G4 for DC-link Current Droop Curve G

The droop curve is bounded with parameters **Overvoltage Limit (2898)** and **Undervoltage Limit (No. 2901)**. The output of the droop curve block in the following illustration 5 is forced to 0 when the DC-link voltage goes outside the overvoltage and undervoltage limits that are set with these parameters.

To make a linear droop curve, the control points must be parameterized in the following way:

- $G1=G2=G3=G4=G^*$
- $I1=I2=-100\%$
- $I3=I4=100\%$

For the DC-link voltage range, use the following points: $U1=$ Undervoltage Ctrl. Level, $U2=U3=100\%$, and $U4=$ Overvoltage Ctrl. Level.

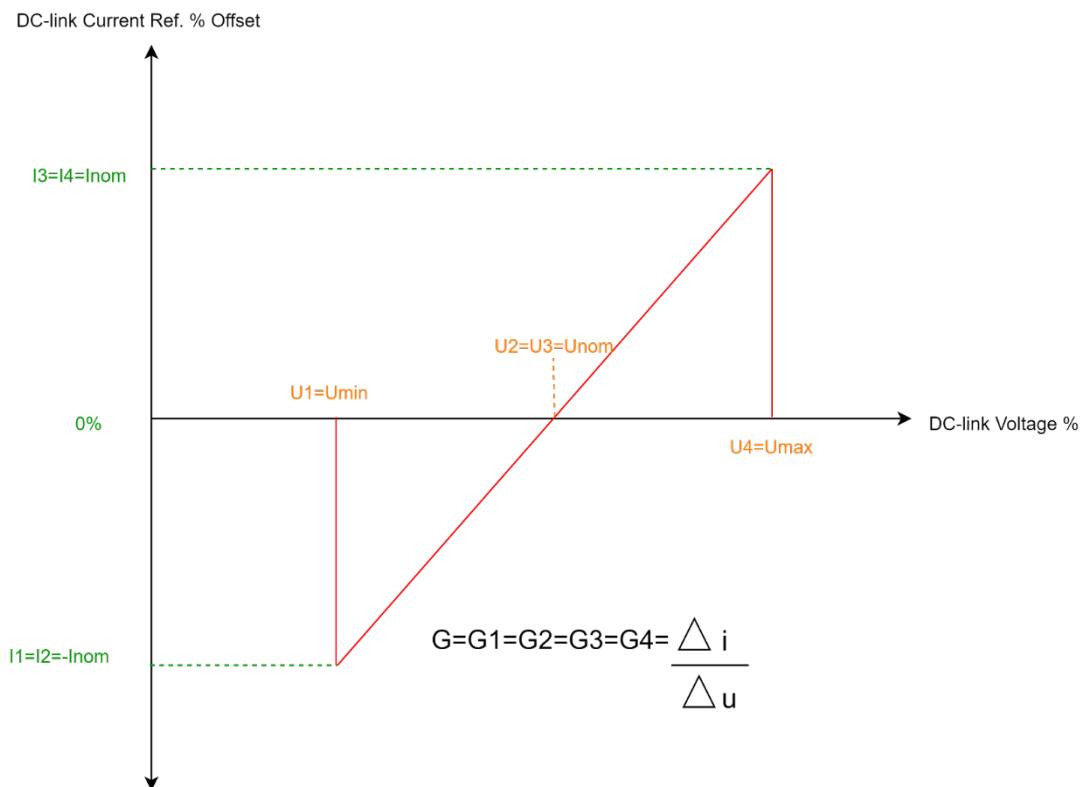

Illustration 5: Linear Current droop curve

For a more advanced droop curve, all the four array elements of the parameters correspond to the following table 4 & Illustration 6:

Table 4: Droop curve configuration

Configuration point	Description	Unit	Range
I1	Maximum current in the negative direction	%	$I1 \leq I2$
I2	Constant current in the negative direction after slope G1	%	$I2 \leq 0$
I3	Constant current in the positive direction after slope G3	%	$0 \leq I3$
I4	Maximum current in the positive direction	%	$I3 \leq I4$
Umin	Minimum DC-link voltage	%	$Umin \leq U1$
U1	Voltage corresponding to I2	%	$U1 \leq U2$
U2	Minimum voltage for 0 current	%	$U2 \leq Unom$
Unom	Nominal DC-link voltage	%	$Unom \leq U3$
U3	Start voltage for slope G3	%	$U3 \leq U4$
U4	Start voltage for slope G4	%	$U4 \leq Umax$
Umax	Maximum DC-link voltage	%	$Umax \geq U1, U2, U3, U4, Unom, Umin$

DC-link Current Ref. % Offset

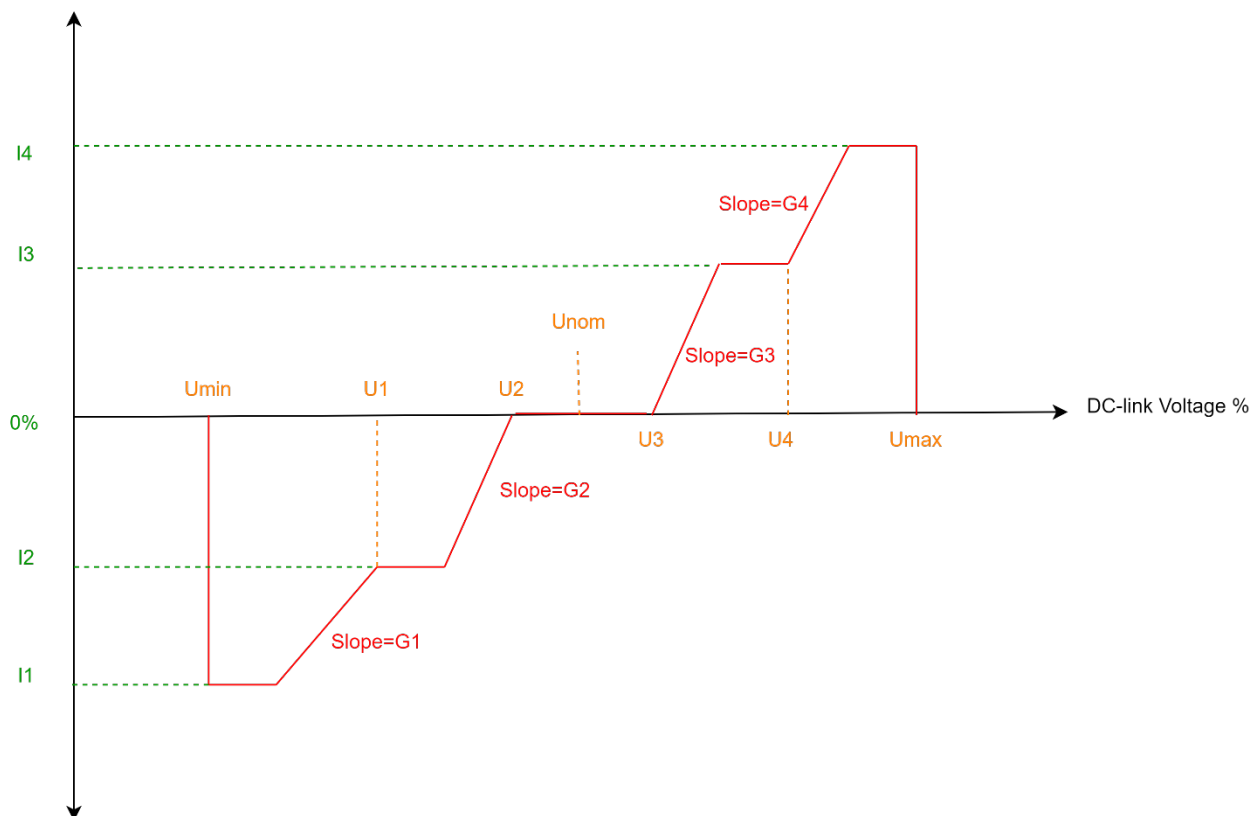
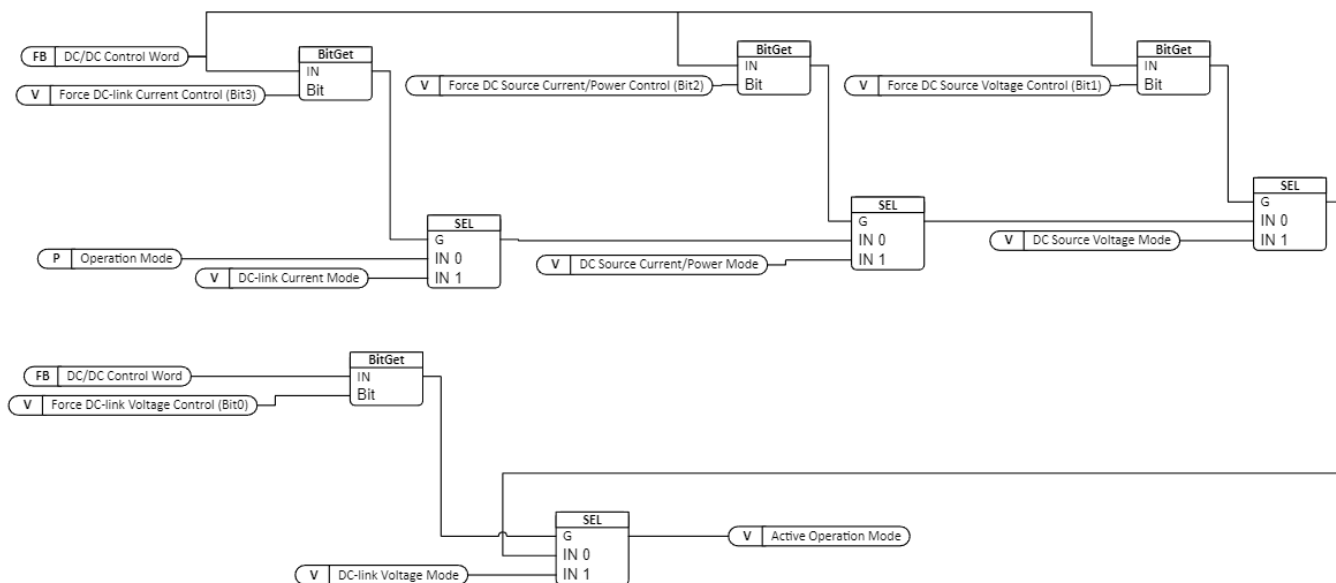

Illustration 6: Advanced droop curve

3.5 Control Mode Prioritization

The handling of operation mode through DC-DC Control Word (No. 90761500) takes priority over the selection made through parameter Operation Mode (No. 2504). As shown in the figure below, the bits ranging from 0 to 3 of DC-DC Control (No. 9076) will override the preceding mode. The priority is in ascending order, therefore bit zero is prioritized over bits when enabled.



3.6 DC Source Voltage Limit Control

DC source voltage limit controllers ensure that the voltage is maintained within the specified minimum and maximum values. If controllers are enabled, the voltage limit control activates when the actual voltage exceeds the limit specified. The activation voltage levels are set with parameters in menu group 2.3 Limits.

If the limit control is activated, the current is controlled to ensure the voltage stays within voltage limit levels. The voltage limit controllers can reverse the converter output current direction to keep the voltage within the specified limit level.

Droop function is available for DC source voltage limit control.

Multiple regulators or limit controllers can be active simultaneously, and the corresponding statuses are shown in the Regulator status word.

3.7 DC-link Overvoltage and Undervoltage Control

Typically, DC-link overvoltage and undervoltage control can be used in source voltage, current, and power control modes to prevent DC-link voltage from falling outside of the specified range, for example when the grid is lost in a DC-backup solution.

The scaling algorithm used in DC-link limit control reference is the same as in DC-link voltage control and also the same ramp rate parameter is used for the limit DC-link limit controller.

Both the overvoltage and undervoltage controllers can be enabled separately. When enabled, the control activates when the actual voltage exceeds the specified limit. The activation voltage levels can be specified by parameter or through fieldbus.

Parallel converters can operate in DC-link undervoltage and overvoltage control with the use of the droop function. The droop gain is the same as that used in DC-link control under menu group 2.5.3 DC-Link Limit.

When the DC-link undervoltage or overvoltage control is active, the current is controlled to ensure that DC-link voltage remains within the voltage limit levels. The voltage limit controllers can reverse the converter output current direction to keep the voltage at the specified limit. The droop gain algorithm is the same which is used in DC-link control in menu group 2.2.5 DC-Link Voltage Reference.

Multiple limit controllers can be active at the same instant and corresponding statuses are shown in the Limit Control Status Word.

NOTICE
The activation of limit controller, such as overvoltage controller, immediately after start is not prohibited as it is typically done in motor control applications.

3.8 Paralleling DC/DC Converters

Paralleling refers to a system in which multiple DC/DC Converters are connected to the same DC-link or to the same DC source. When multiple power units operate under one control unit, it is considered a single DC/DC Converter from the system level paralleling point of view.

The following illustration represents the typical paralleling configurations:

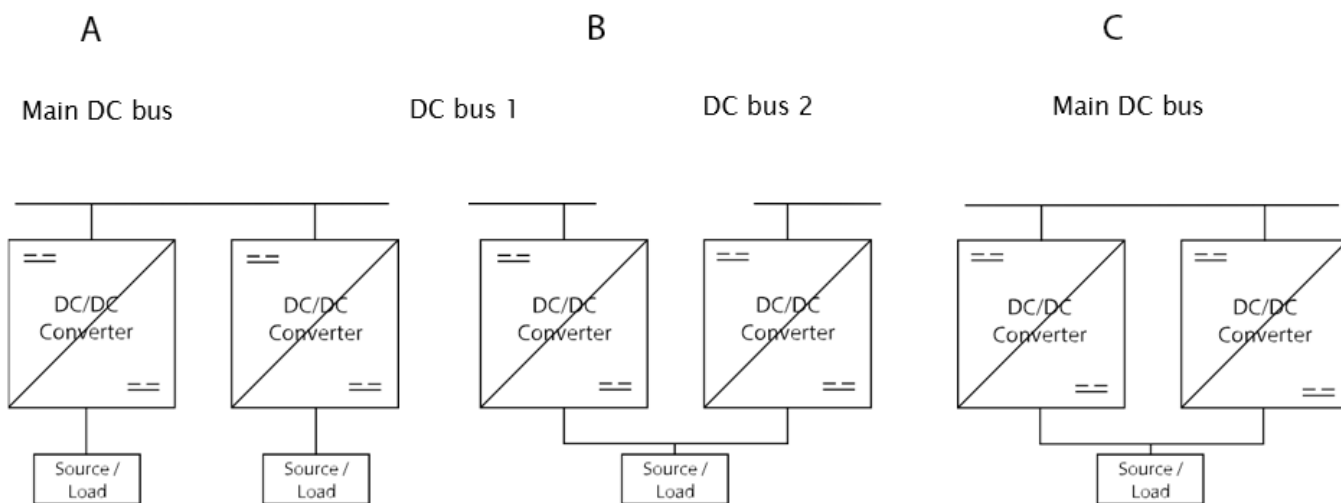

Illustration 7: Topologies of paralleling configurations

DC/DC converters can operate in parallel using current control and power control modes, as each individual converter has its own current reference. Droop control is required in voltage control modes to balance the load.

The following table illustrates the relevant parameters for paralleling of DC/DC Converters:

Table 5: Topologies and Required Configuration

Topology	Control references that need drooping
Common DC-link (A)	DC-link voltage control DC-link overvoltage and undervoltage control
Common DC source (B)	Source voltage control Source voltage limit control
Common DC-link and common DC source (C)	DC-link voltage control DC-link over and undervoltage control Source voltage control Source voltage limit control

3.8.1 Paralleling Using Droop Control

Droop voltage control is available for source voltage, source voltage limit control, DC-link voltage control, and DC-link undervoltage and overvoltage control.

Droop control enables load sharing between parallel converters with individual control units and eliminates the need for converter-to-converter communication. Droop control modifies the reference voltage as a function of output current. In this way the entire output current is never provided when the controlled voltage is at reference.

Droop control ensures that the integral action of the voltage controllers prevents the converters from competing against each other, for example due to voltage measurement tolerances. By employing droop control, the converters autonomously share the load, irrespective of the number of parallel converters.

3.8.2 Droop Control Calculation

The droop gain k , or the slope, is defined as the ratio of voltage change to the current change as follows: $k = \Delta V(\%) / \Delta I(\%)$

where:

- k = droop gain
- $\Delta V(\%)$ = percentage change in controlled voltage
- $\Delta I(\%)$ = percentage change in converter current

The final voltage reference modified by the droop is:

- $V_{ref\ final}(\%) = V_{ref}(\%) - kI(\%) = V_{ref}(\%) - \Delta V_{ref}(\%)$

The droop slope produced on the reference is exemplified in the following illustration when $k = 4\%$

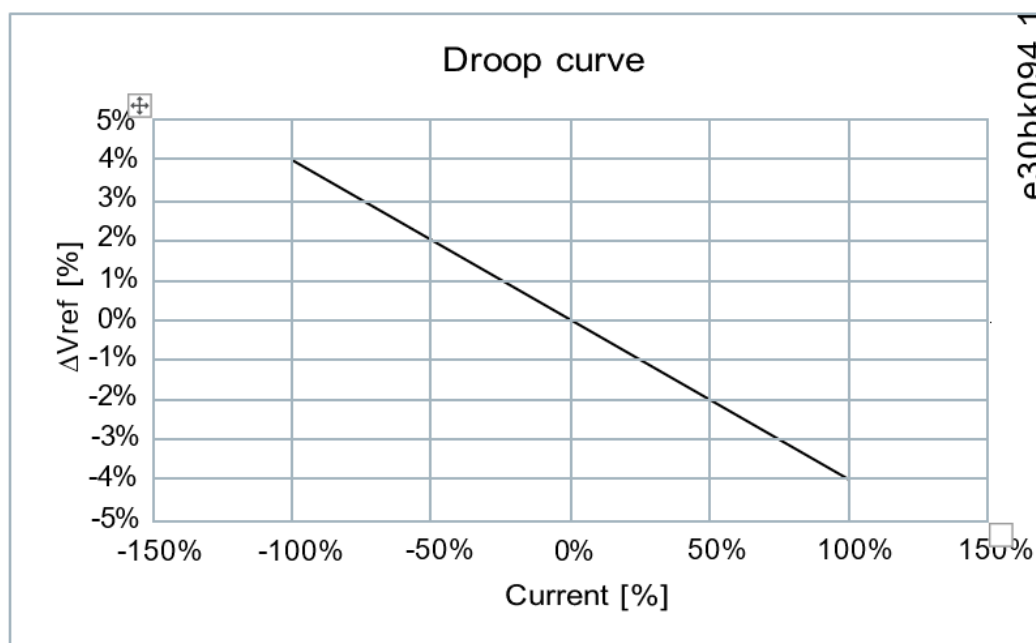

Illustration 8: Example of droop curve

If the goal is to maintain the DC voltage at the reference level regardless of the load, the power management system must adjust the common voltage reference for all converters operating on the same DC bus after a load change occurs.

For example, in a system where droop is set according to illustration 8, the voltage decreases by 4% when load current is 100%. To maintain the voltage in the original reference, the power management system monitors the system, and in this case increases the voltage reference by 4%.

Droop Control behavior is illustrated in illustration 9. The points A-B-C-D describe the behavior with positive current and A-E-F-G with negative current. In the beginning, the operating point is A with no load. After that, the current increases to 100% positive output, and the operating point moves to point B, with the voltage reference offset by -4%. The upper control compensates for the droop effect by increasing the centralized voltage reference given to all voltage controlling units, and the operating point moves to C. If the system is unloaded, the operating point moves from C to D and the upper control must adjust the centralized reference to return the system back to the desired voltage. The points A-E-F-G-A define the behavior with negative current.

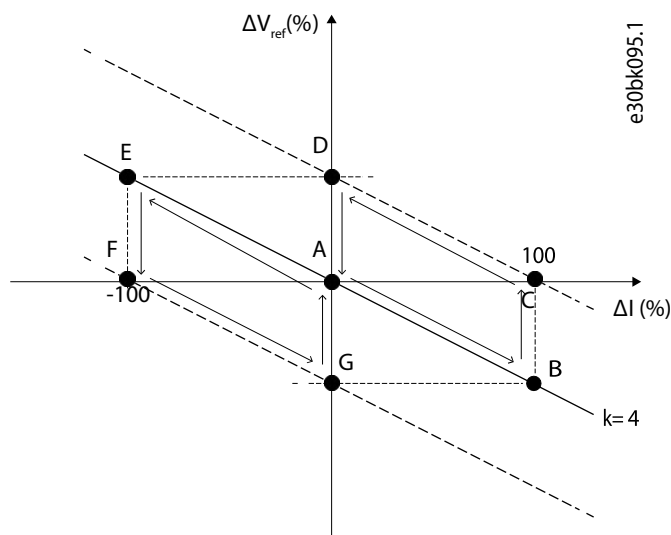

Illustration 9: Droop Control Behavior

When DC bus voltage drooping is enabled, the DC voltage decreases as a function of the load current. The DC voltage reference and drooping gain are set so that the requirement for maximum ratio between DC-link voltage and DC-source voltage is satisfied. For example, if the minimum ratio is set to 102% and the drooping is set to 3%, the DC voltage reference is set to 106% to cover the 110% overload. Ratio between DC-link voltage and DC-source voltage should be higher than 103% to achieve nominal control performance.

Pre-Charging the Filter Capacitor Before Connecting the Source

If a filter capacitor is used with the DC/DC Converter, it must be pre-charged before it is connected to the DC source, to avoid a high inrush current peak. A pre-charging resistor can be connected between the DC/DC Converter terminals and the DC-source to pre-charge the filter capacitor and the DC-bus (in case the DC-bus voltage is not equal or higher than the DC-source voltage already).

Alternatively, the following sequence can be used to charge the filter capacitor before connecting the DC source:

1. Pre-charge the DC bus.
2. Set the source voltage reference to the same value as the measured source voltage (as measured by the BMS for example)
3. Set the current limit to a low value, for example 1%, to avoid a large current flow if there is a difference between the converter voltage and the actual source voltage.
4. Connect the DC source.
5. Start operation with the required operating mode and current limit.

3.9 DC Source Supervision

3.9.1 DC Source Current Supervision

The DC Source Current Supervision feature monitors the DC source current and detects when it is outside of the set limits: current magnitude limit, positive direction DC source current limit, and negative direction DC source current limit. The converter can be configured to issue a warning if the limits are exceeded. DC Source Superv. Status Word (No. 2968) shows the present status of the supervision.

A configurable delay is applied to detecting and resetting the limit passing condition. Also, a configurable margin is applied to the above limits. DC/DC Converter can operate as long as the source current stays in the margin so it can run against the current limits.

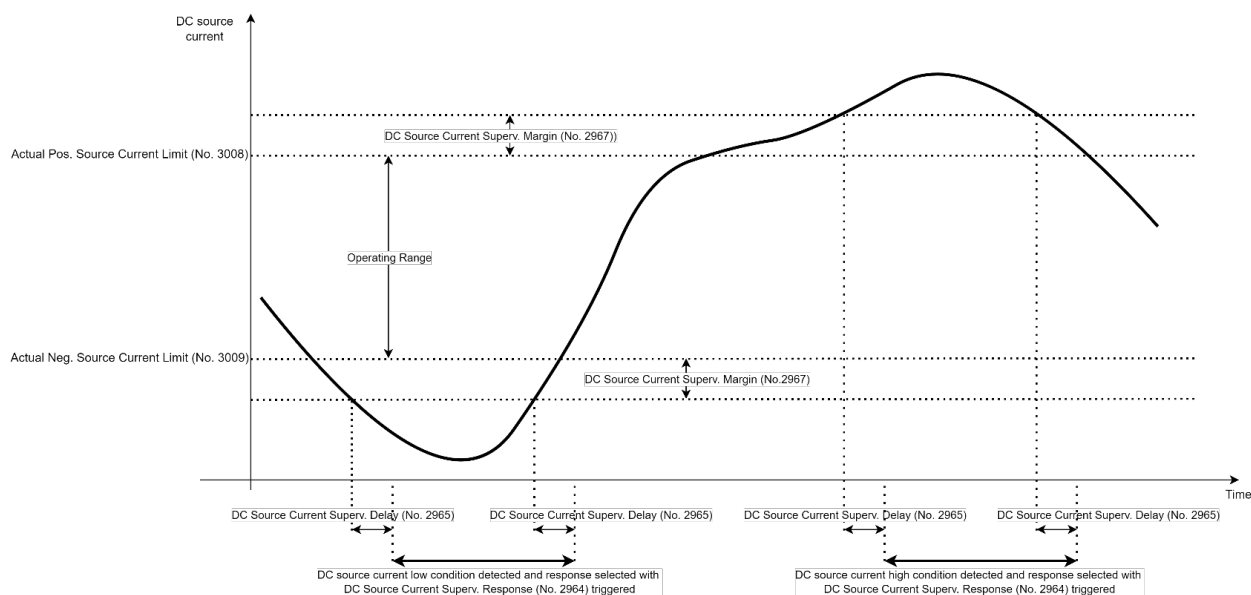

Illustration 10: DC Source Current Supervision

3.9.2 DC Source Voltage Supervision

The DC Source Voltage Supervision feature monitors the DC source voltage and detects when it is outside of the set limits: minimum DC source voltage limit and maximum DC source voltage limit. If the limits are exceeded, the converter can issue a configurable response. The available responses are:

- No response
- Warning
- Warning in Stop State, Fault in Run State
- Fault

DC Source Superv. Status Word shows the present status of the supervision.

A configurable delay is applied for detecting and resetting the limit passing condition. Also, a configurable margin is applied to the above limits. DC/DC Converter can operate as long as the source voltage stays in the margin so it can run against the voltage limits.

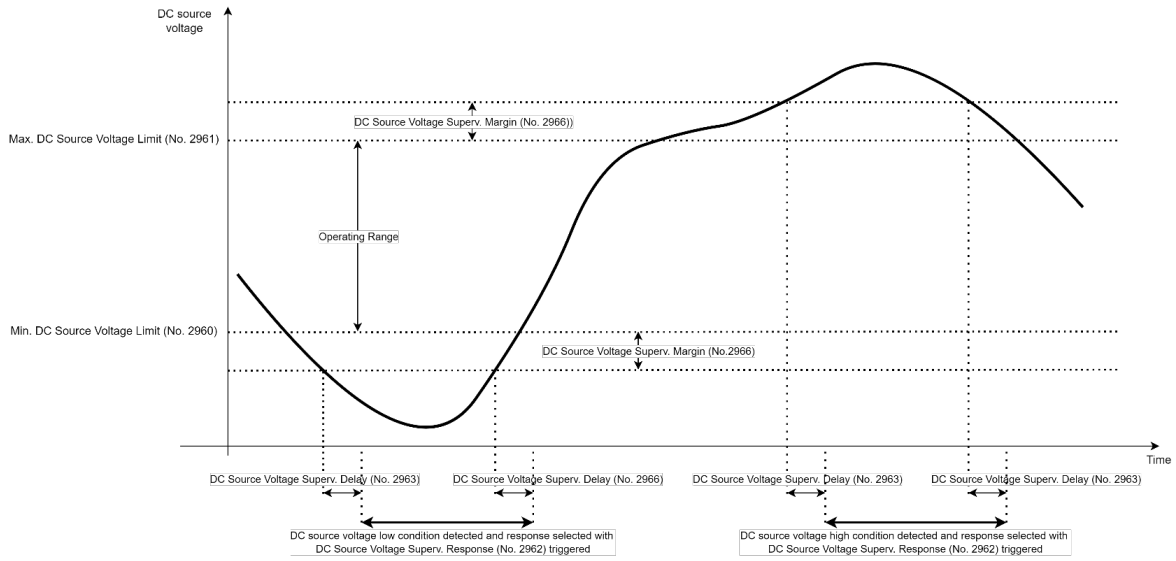

Illustration 11: DC Source Voltage Supervision

4 Control Places

4.1 Overview of Control Places

DC/DC Converter can be controlled from four different control places. If there are simultaneous control requests from PC control and local control, and for control place forcing, the priority order of the control places is as follows:

1. PC control
2. Local control
3. I/O control
4. Fieldbus control

Control place can be changed during the run state as described in the following chapters.

4.2 Control place selection

Illustration 12 shows the control place selection chain diagram. The default method for selecting the control place is by using the parameter Control Place Selection (No. 114). It can be used to select the active control place between local (Control Panel), fieldbus, and I/O.

The second option for control place selection is to use control place forcing signals. This method overrides the selection made with the parameter Control Place Selection and can be used to swap between different control places via external push buttons or switches, for example. The forcing signals for fieldbus and I/O can be mapped to digital inputs or the fieldbus, and the local control forcing is activated with the REM/LOC button of the control panel.

The priority order for control place forcing is configured with parameter Control Place Forcing Priority (No. 4732). If two or more control places are forced on simultaneously, the priority order affects the final control place selection. For example, if fieldbus is selected for highest priority [Index (0) in Illustration 35] and I/O for the next highest priority [Index (1) in Illustration 35], and both control places are forced on simultaneously, fieldbus is selected as the active control place because it is configured for higher priority than I/O. After fieldbus forcing is removed, the control place will fall to I/O because it has higher priority than the parameter selection.

The only control place which can take over control from any other control place regardless of forcing inputs is PC control (MyDrive Insight).

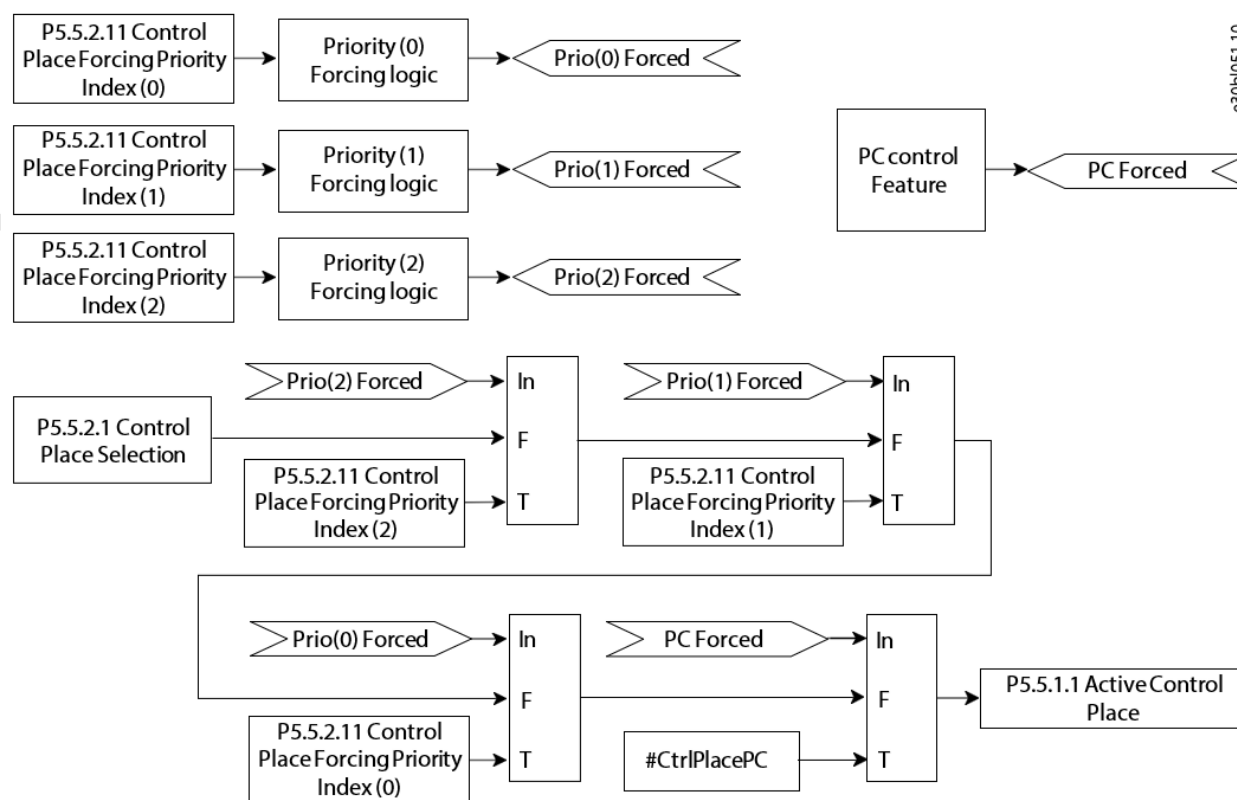

Illustration 12: Control Place priority chain

Each control place defines the source for start, stop, and warning/fault reset commands. The latter depends on parameter Control Place Independent Reset (No. 109).

The reference which must be followed is configured by reference selection parameters, independently from the selected control place. The following table shows the reference and limit controller source selections which are available:

Table 6: Reference and Limit Controller Source Selection

References and limit controllers/Source	Parameters	Fieldbus	Analog input
Source Voltage Reference	X	X	
Source Current Reference	X	X	X
Neg. DC Source Current Limit	X	X	X
Pos. DC Source Current Limit	X	X	X
Neg. DC Source Power Limit	X	X	X
Pos. DC Source Power Limit	X	X	X
DC-Link Voltage Reference	X	X	
DC-link Current	X	X	
Overvoltage Control	X	X	
Undervoltage Control	X	X	

4.3 I/O Control

In I/O Control, the converter can be started or stopped with the parameter I/O Start Input (No. 200). A stop command can also be issued with the parameter I/O Stop Input (No. 201). Faults and warnings can be reset while in I/O control with the parameter I/O Reset Input (No. 203).

The start and stop mode of the converter can be configured with the parameter I/O Start Mode (No. 213). The following start and stop modes can be selected:

Table 7: I/O Control start and stop modes.

Selection Number	Name	Description
0	State sensitive	<ul style="list-style-type: none"> • A high state of the signal is the start request. • The converter stops if the start signal is removed. • If the start signal is high when a fault is cleared, or an <i>I/O Stop Input</i> signal is removed, the converter starts running immediately. • An <i>I/O Stop Input</i> or <i>Switch On Enable Input</i> signal prevents the converter from starting.
1	Rising edge	<ul style="list-style-type: none"> • A combination of a rising edge and high state of the signal is the start request. • The converter stops if the start signal is removed. • If the start signal is high when a fault is cleared, or an <i>I/O Stop Input</i> signal is removed, the converter does not start running. • An <i>I/O Stop Input</i> or <i>Switch On Enable Input</i> signal prevents the converter from starting.
2	Pulse	<ul style="list-style-type: none"> • A rising edge of the signal is the start request. • A rising edge of an <i>I/O Stop Input</i> signal stops the converter. • If the start signal is high when a fault is cleared, or an <i>I/O Stop Input</i> signal is removed, the converter does not start running. • An <i>I/O Stop Input</i> or <i>Switch On Enable Input</i> signal prevents the converter from starting.

4.4 Fieldbus Control

The fieldbus control place allows the sending of control commands based on the fieldbus profile. The fieldbus status word is always available and updated irrespective of the active control place. The fieldbus start and stop mode is configured with the parameter Fieldbus Start Mode (No. 5114). Start and stop modes are similar to the IO control except that in the fieldbus control only State and Rising Edge start modes are supported.

Table 8: Fieldbus Control Start and Stop Modes

Selection number	Name	Description
0	State sensitive	<ul style="list-style-type: none"> The high state of bit 3 (the Start and Stop bit) is the start request. If bit 3 is false, the converter stops. If the start bit is high when a fault is cleared, the converter starts running immediately. Switch on enable (bit 0) can block the start.
1	Rising edge	<ul style="list-style-type: none"> The combination of a rising edge and high state of bit 3 (the Start and Stop bit) is the start request. When bit 3 is false the converter stops. The converter does not start running in case bit 3 is true when a fault is cleared. Switch on enable (bit 0) can block the start.

4.4.1 Fieldbus Control Word and Bit Descriptions

Table 9: Fieldbus Control Word

Bit	Name	Description	Further Information
0	Switch On Enable	0: Running is prevented or interrupted 1: Running is not prevented or interrupted	This bit behaves as start and run interlock. When this bit is set to high (True), only then control word bit 3 can enable operation of the unit. Whenever this bit falls to low (False) state while running, the unit is forced to stop.
1	--	Reserved	
2	Quick Stop	0: Activate Quick Stop. 1: Do not activate Quick Stop.	
3	Start	0: Stop modulation if the unit is running 1: Start modulation or keep the unit running	Depending on Fieldbus Start Mode (No.5114) a rising edge or state high is required for DC-link pre-charging to start thus moving from Ready State to Run State
4	--	Reserved	
5	--	Reserved	
6	--	Reserved	
7	Warning/Fault Reset	0: No action. 1: Reset active warnings/faults.	This bit is used to acknowledge faults in the converter. A rising edge (a transition from false to true) on this bit issues an event reset request.
8	--	Reserved	
9	--	Reserved	

Bit	Name	Description	Further Information
10	Data Valid	0: Ignore the current incoming process data values, instead use the last processed value when the Data Valid bit was true. 1: Use the current incoming process data values.	For Modbus protocol, Data Valid bit functionality is currently present in the pre-configured control word only. If the control word is mapped to another register with Modbus Customizer, this bit is not considered, and the message is accepted regardless.
11	Watchdog	Incoming fieldbus watchdog bit	This is the input bit used for the fieldbus watchdog.
12	Vendor Specific Bit 1	0: Deactivate the vendor specific function using digital input 1: Activate the vendor specific function using digital input	
13	Vendor Specific Bit 2	0: Deactivate the vendor specific function using digital input 1: Activate the vendor specific function using digital input	
14	Vendor Specific Bit 3	0: Deactivate the vendor specific function using digital input 1: Activate the vendor specific function using digital input	
15	Vendor Specific Bit 4	0: Deactivate the vendor specific function using digital input 1: Activate the vendor specific function using digital input	

When the control place is not fieldbus, all bits other than **Data Valid** and **Watchdog** are ignored. However, depending on parameter.

Control Place Independent Reset (No. 109), Warning/Fault Reset bit can also reset the faults independent of the active control place.

4.4.2 Fieldbus Status Word and Bit Descriptions

Table 10: Fieldbus Status Word

Bit	Name	Description	Further information
0	Ready to Switch On	0: Not ready to switch on 1: Ready to switch on	This bit is true if all following conditions are satisfied: <ul style="list-style-type: none"> • Switch on enable is present. • Quick stop is not requested. • No faults are active
1	Ready to Run	0: Converter is not ready to start modulation (Check the <i>DC/DC Control Ready Status & Application Ready Status Word</i>) 1: Converter is ready to start modulating	All the bits of DC/DC Control Ready Status as well as the Application Ready Status needs to be high to get the Ready to Run true.
2	Running	0: Converter is not modulating 1: Converter is modulating	
3	Fault	0: No faults are active 1: One or more faults are active	
4	--	Reserved	
5	Quick Stop	0: Quick stop active 1: Quick stop not active	
6	--	Reserved	
7	Warning	0: No warnings active 1: One or more warnings are active	
8	--	Reserved	
9	Control by PLC	0: The active control place is not fieldbus 1: The active control place is fieldbus	
10	--	Reserved	
11	Run Enabled	0: Run enable from the dedicated input signal is missing 1: Run enable from the dedicated input signal is present	
12	--	Reserved	
13	--	Reserved	
14	--	Reserved	
15	Watchdog	Outgoing fieldbus watchdog bit	

4.4.3 DC/DC Control Word and Bit Descriptions

Table 11: DC/DC Control Word

Bit	Name	Description
0	DC-Link Voltage Control Forcing	0: No action 1: Forces the operating mode to DC-Link Voltage Control
1	DC Source Voltage Control Forcing	0: No action 1: Forces the operating mode to DC Source Voltage Control
2	DC Source Current/Power Control Forcing	0: No action 1: Forces the operating mode to DC Source Current/Power Control
3	DC-link Current Control Forcing	0: No action 1: Forces DC-link Current Control
4	Zero Pos. Current Limit Forcing	0: No action 1: Forces the Positive Current Limit to zero
5	Zero Neg. Current Limit Forcing	0: No action 1: Forced the Negative Current Limit to zero
6–31	--	Reserved

All DC/DC Control Word bits simply override the respective parameter settings, but do not change them. Also, the overriding happens only when the control place is fieldbus, otherwise setting these bits has no effect. Bits 0, 1 and 2 override the selected unit operating mode. If more than one of these bits are true, their priority is as follows (from highest to lowest):

- bit 0
- bit 1
- bit 2
- bit 3

For example, if bit 0 is true, bit 1 is false and bit 2 is true, then bit 0 prevails and the unit operation mode is forced to DC-Link Voltage Control.

4.4.4 Custom Status Word and Bit Descriptions

The Custom Status Word is a fully customizable status word. The bits of this status word can be programmed to collect any bit from the following status words:

- DC/DC Control Mode Selection Status Word
- Application Specific Status Word 1
- Application Specific Status Word 2
- Limit Control Status Word
- DC Source Supervision Status Word

The default configuration is shown in the following table:

Table 12: Custom Status Word

Bit	Configuration	Description
0	Bit 0 from DC/DC Ctrl. Mode Selection Status Word	Shows whether the converter is operating in DC Source Current Control mode
1	Bit 1 from DC/DC Ctrl. Mode Selection Status Word	Reserved
2	Bit 2 from DC/DC Ctrl. Mode Selection Status Word	Shows whether the converter is operating in DC Source Voltage Control mode
3	Bit 3 from DC/DC Ctrl. Mode Selection Status Word	Shows whether the converter is operating in DC-Link Voltage Control mode
4	Not configured	Not configured
5	Bit 1 from Application Specific Status Word 2	Toggled warning indication
6	Bit 2 from Application Specific Status Word 2	Toggled fault indication
7–15	Not configured	Not configured

4.5 Local Control

Local control can only be requested from the control panel. The request is triggered by a rising edge signal, so pressing the Rem/Local button initiates the request or releases local control. Only start and stop are possible using the respective buttons in the Control Panel, but the Stop button stops the converter irrespective of the active control place. It is also possible to reset a fault from the active fault screen.

4.6 PC Control

PC control can be requested from takeover requested using the PC tool, MyDrive Insight. The converter can be started and stopped using MyDrive Insight. There is also a fault reset button. No reference can be set using PC tool, My Drive Insight and even the reference field of the My Drive Insight can allow to set a reference, it is not taken into use.

5 Quick Start up & Configuration Examples

5.1 Configuring an energy storage application

In applications including energy storage, the source nominal values, current, and voltage limits must be carefully set according to the storage medium that is used. The configuration parameters that must be checked during commissioning are listed in the table 13:

Table 13: Energy Storage Parameters

Menu index	Parameter name	Recommended setting	Unit	Description
2.1.1	DC Source Nominal Voltage	Set according to Energy Storage nominal voltage.	V	Defines percentage scaling.
2.1.2	DC Source Nominal Current	Set according to Energy Storage nominal current.	A	Defines percentage scaling.
2.1.3	DC-link Nominal Voltage	Set according to DC-bus nominal voltage.	V	Defines percentage scaling.
2.3.2.2	Current Limit	Set according to preferred maximum current, in percentage of source nominal current.	%	Total current limit
2.3.2.3	Neg. DC Source Current Limit	Set if discharge current must be smaller than the current limit.	%	Set if discharge current is different compared to the current limit.
2.3.2.4	Pos. DC Source Current Limit	Set if charge current must be smaller than the current limit.	%	Set if charge current is different compared to the current limit.
2.3.1.1	Min. DC Source Voltage Limit	Set minimum Energy Storage voltage level to ensure safe operating area is not violated.	%	
2.3.1.2	Max. DC Source Voltage Limit	Set maximum Energy Storage voltage level to ensure safe operating area is not violated.	%	

5.2 Configuring the Operating Mode and DC-Link Limit Controls

The operating mode of the converter should be selected according to the requirements of the system. Parameters affecting the operating mode selection are listed in table 14. DC-link voltage control uses the same reference scaling as over and undervoltage control (see table 15). Source current and power mode can be selected by the combination of both the operation mode and reference mode.

Table 14: Operating Mode

Parameter	Description
2.2.1.1 Operation Mode	Selections: <ul style="list-style-type: none"> • 0: Source current/power • 1: DC-link current • 2: Source voltage • 3: DC-link voltage
2.2.1.2 Converter Reference Mode	Selections: <ul style="list-style-type: none"> • 0: Current • 1: Power

iC7-Hybrid applications provide a parameter to set the system nominal DC-link voltage level. When all units connected to the same DC-link share the same nominal DC-link voltage level, it is easy to set parameters in a consistent way. For example, the overvoltage and undervoltage controller limits can be set on the same scale for all different types of converters and drives in the same system. Parameters affecting the DC-link limit control are listed in table 15.

Table 15: Configuring DC-Link Limit Controllers

Parameter	Unit	Description
2.1.3 DC-link Nominal Voltage	V	Nominal voltage of the system DC bus.
2.3.4.1.3 Undervoltage Limit	%	Limit control activation level in percentage of the nominal DC-link voltage.
2.3.4.2.3 Overvoltage Limit	%	Limit control activation level in percentage of the nominal DC-link voltage.
2.3.4.2.1 Overvoltage Control	-	Selections: <ul style="list-style-type: none"> • 0: Disabled • 1: Enabled
2.3.4.1.1 Undervoltage Limit	-	Selections: <ul style="list-style-type: none"> • 0: Disabled • 1: Enabled

In charging applications, the preferred charging profile depends on the technology of the storage system. To achieve typical constant current and constant voltage charging methods for Li-Ion batteries, the following can be applied: The DC/DC Converter operates in the source voltage control mode to charge the energy storage into the desired final voltage, and the current limits are adjusted to achieve regions of constant current charging. Alternatively, current control mode and source voltage limits can be used.

The easiest way to create a peak-shaving application is to use the DC/DC Converter to maintain the DC-link voltage using the in the DC-link voltage control mode. DC-link voltage control maintains the power balance of the DC-bus automatically. When there is more load than power supplied to the DC-bus, the energy storage is discharged. Energy storage is charged when there is excess power generation. The main power source of the system is controlled to keep the energy storage charge in the normal operating area (for example, using PQ control in Grid Converter). Alternatively, the DC/DC Converter can be used in power reference mode, and high-pass filtered load power fed to the DC/DC Converter as a reference.

In DC backup application, the DC/DC Converter is used in source voltage control mode to charge the energy storage to full charge when normal power supply is available. The DC-link undervoltage limit should be set so that when the main supply is lost, the DC/DC Converter maintains the DC-link voltage at adequate level using the undervoltage controller. The undervoltage controller limit of the inverter units must be set to a lower value than the DC/DC undervoltage control limit. When the main power supply returns, the DC/DC Converter continues in source voltage control mode to charge the energy storage.

If parallel DC/DC Converters are connected to the same energy storage or DC link, set the source and DC-link voltage droop parameters listed in table 16.

Table 16: Droop Parameters

Parameter	Unit	Description
2.2.5.4 DC-link Voltage Droop Gain	%	Defined in percentage of the nominal DC-link voltage. The gain is common for DC-link voltage control and the undervoltage and overvoltage controls.
2.2.3 DC Source Voltage Droop Gain	%	Defined in percentage of the nominal source voltage. The gain is common for source voltage control and source voltage minimum and maximum limit control.

5.3 Configuring the DC-Link Current Control

The DC-link current control mode is used when the power management system controls the DC-link current directly with their own reference chains.

Table 17: DC-link current control parameters

Parameter menu index	Parameter name	Unit	Description
2.2.1.1	Operation Mode	-	Set to 1: DC-Link Current Control.
2.1.3	DC-Link Nominal Voltage	V	Defines the nominal DC-link voltage used for scaling the references and overvoltage and undervoltage limits, as well as for drooping.
2.2.6.2	DC-link Current Ref.	%	Defines the DC-link current reference in percentage of the nominal DC-link current.

6 Menu Structure

6.1 Understanding Application Menu Structure

- Menu structure is designed based on the principles to make the commissioning easier and better user friendliness.
- Basic idea is to divide the menu into two parts: Group 1. Monitoring which has all the readouts and status words. The rest of the groups are used to configure the application parameters based on different configuration examples and all the features.

6.1.1 Application Menu Structure

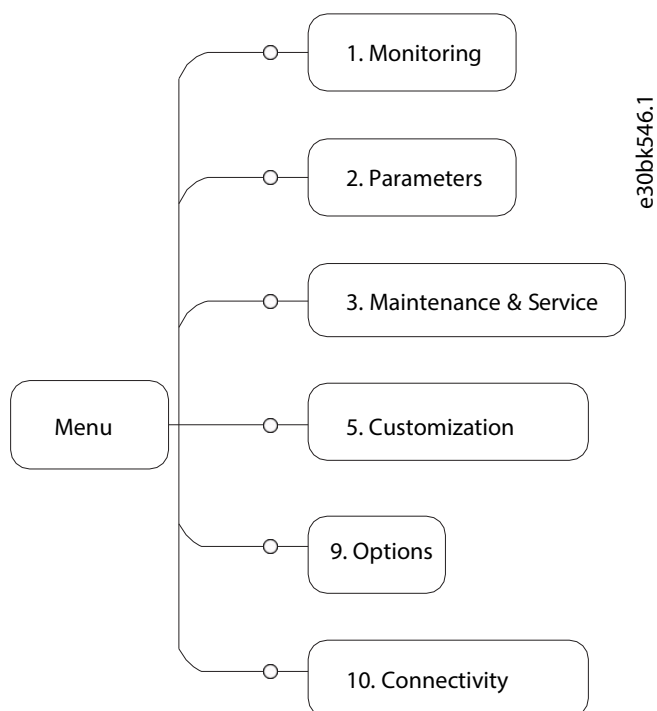

Figure 64: Menu Structure

Table 24: Parameter Groups

Menu index	Parameter group name	Description
1	Monitoring	Contains parameters for the configuring, monitoring, and controlling the DC source.
2	Parameters	Contains parameters to configure, monitor, and control the power conversion of the converter. The menu makes it possible to configure protection settings of the power unit and settings for the DC bus.
3	Maintenance & Service	Contains parameters to configure the filters.
5	Customization	Contains application specific parameters.
9	Options	Contains parameters to configure IO & Relay, Temperature Measurement and Voltage Measurement.
10	Connectivity	Parameters to configure the inbuilt and optional communication of the converter system.

This chapters contain tables presenting the basic attributes of each parameter available in the application software. Each chapter represents a single subgroup within the menu structure.

The tables have the following format:

[1]: Value depends on the power unit specification.

Index	Name	Num	Min	Max	Default	Unit	Reso	Handling Type	Data Type
1.2.3.4.5	Parameter Name	1234	-10.0 ^[1]	10.0 ^[1]	0.0	Hz	0.01	Config	REAL
6.7.8	Array Parameter Name	5678	0	5	[1,2]		1	Config	UINT

- Index: shows the location of the parameter within the menu structure.
- Name: shows the parameter name.
- Num: shows the parameter number.
- Min: shows the minimum value that the parameter can have. For arrays the single given value applies to all array elements.
- Max: shows the maximum value that the parameter can have. For arrays the single given value applies to all array elements.
- Default: shows the value that the parameter has with factory default settings. For arrays each element value is shown comma-separated within square brackets.
- Unit: shows the unit symbol of the parameter. Nothing is shown if the parameter is unitless.
- Reso: shows the resolution or display/edit precision of the parameter.
- Handling Type: shows whether the drive handles the parameter as a constantly changing *process* value or an infrequently changed *configuration* value. Use this field as a guide for evaluating how often to write to parameters when creating custom fieldbus configurations.
- Data type: shows the IEC 61131 elementary data type of the parameter.
- Possible references within any field will note special conditions that are explained below the table.

6.1.2 Understanding Data Types

The following is an overview of the data types used in the iC7 application software. They are IEC 61131 elementary data types.

Data type	Description	Size (Bits)	Range
BOOL	Boolean	1	0...1
INT	Integer	16	-32,768...32,767
DINT	Double Integer	32	-2,147,483,648 up to 2,147,483,647
USINT	Unsigned short integer	8	0 up to 255
UINT	Unsigned integer	16	0 up to 65,535
UDINT	Unsigned double integer	32	0 up to 4,294,967,295
REAL	Real numbers	32	-3.402823466 E+38 (approximately 7 digits) up to -1.175494351E-38 (approximately 7 digits) and +1.175494351 E-38 (approximately 7 digits) up to +3.402823466 E+38 (approximately 7 digits)
WORD	Bit string of length 16	16	0...65,535 (16#00...16#FFFF)
STRING	Sequence of characters	N/A	1 Byte per character
ULINT	Unsigned long integer	64	0 - 18446744073709551615
DATE_AND_TIME	Date and time information	64	N/A

6.2 Monitoring

6.2.1 Basic Monitoring

Index	Name	Number	Min	Max	Default	Unit	Reso	Handling Type	Data type
1.1.1	DC Source Current	9000	0.0	3.4e+38	0.0	A	1	Process	REAL
1.1.2	DC Source Voltage	9055	0.0	3.4e+38	0.0	V	0.1	Process	REAL
1.1.3	DC-link Current	5115	-6000.0	6000.0	0.0	A	1	Process	REAL
1.1.4	DC-link Voltage	9044	0.0	3.4e+38	0.0	V	0.1	Process	REAL
1.1.5	Application Status Word 1	6201	0x0	0xffff	0x0		1	Process	WORD
1.1.6	Application Status Word 2	6202	0x0	0xffff	0x0		1	Process	WORD
1.1.7	Fault Status Word 1	6203	0x0	0xffff	0x0		1	Process	WORD
1.1.8	Fault Status Word 2	6204	0x0	0xffff	0x0		1	Process	WORD
1.1.9	Warning Status Word 1	6205	0x0	0xffff	0x0		1	Process	WORD
1.1.10	Warning Status Word 2	6206	0x0	0xffff	0x0		1	Process	WORD
1.1.11	Last Fault Number	1610	0	65535	0		1	Process	UINT
1.1.12	Last Warning Number	1609	0	65535	0		1	Process	UINT
1.1.13	DC/DC Control Status Word	6545	0x0	0xffff	0x0		1	Process	WORD
1.1.14	DC/DC Control Ready Status Word	6520	0x0	0xffff	0x0		1	Process	WORD
1.1.15	Application Ready Status Word	6525	0x0	0xffff	0x0		1	Process	WORD
1.1.16	Limit Control Status Word	9080	0x0	0xffff	0x0		1	Process	WORD
1.1.17	DC-link Nominal Current	5120	0.0	3.4e+38	0.0	A	0.01	Process	REAL
1.1.18	DC Source Nominal Power	5121	-3.4e+38	3.4e+38	0.0	kW	1	Process	REAL

6.2.2 Control Mode and Reference Monitoring

Index	Name	Number	Min	Max	Default	Unit	Reso	Handling Type	Data type
1.2.1	Active Operation Mode	169	0	3	0		1	Process	UINT
1.2.2	DC/DC Operation Mode Selection Status Word	9079	0x0	0xffff	0x0		1	Process	WORD
1.2.3	DC Source Voltage Ref.	2883	0.0	1000.0	100.0	%	0.01	Process	REAL
1.2.4	DC Source Current Ref.	2884	-1000.0	1000.0	0.0	%	0.01	Process	REAL
1.2.5	DC Source Power Ref. (Actl.)	273	-1000.0	1000.0	0.0	%	0.1	Process	REAL
1.2.6	DC-link Current Ref. Actual	6141	-3.4e+38	3.4e+38	0.0	%	0.1	Process	REAL
1.2.7	DC-link Voltage Ref. Actual	6543	-16777216.0	16777216.0	0.0	%	0.01	Process	REAL

6.2.3 Limit Monitoring

Index	Name	Number	Min	Max	Default	Unit	Reso	Handling Type	Data type
1.3.1	Limit Control Status Word	9080	0x0	0xffff	0x0		1	Process	WORD
1.3.2	Actual DC Source Current Limit	2700	0.0	300.0	0.0	%	0.01	Process	REAL
1.3.3	DC Source Power Limit Neg.	2909	-1000.0	0.0	-300.0	%	0.01	Process	REAL
1.3.4	DC Source Power Limit Pos.	2913	0.0	1000.0	300.0	%	0.01	Process	REAL
1.3.5	Overvoltage Control Limit	6544	-16777216.0	16777216.0	796.5	V	0.01	Process	REAL
1.3.6	Undervoltage Control Limit	6546	100.0	1300.0	100.0	V	0.01	Process	REAL
1.3.7	Actual Neg. DC Source Current Limit	3009	-300.0	300.0	0.0	%	0.01	Process	REAL
1.3.8	Actual Pos. DC Source Current Limit	3008	-300.0	300.0	0.0	%	0.01	Process	REAL

6.2.4 Control Place Monitoring

Index	Name	Number	Min	Max	Default	Unit	Reso	Handling Type	Data type
1.5.1	Active Control Place	113	0	3	0		1	Process	UINT
1.5.2	FB Forcing Requested	116	0	1	0		1	Process	BOOL
1.5.3	I/O Forcing Requested	117	0	1	0		1	Process	BOOL
1.5.4	Local Control Forcing Requested	124	0	1	0		1	Process	BOOL

6.2.5 DC Source Monitoring

Index	Name	Number	Min	Max	Default	Unit	Reso	Handling Type	Data type
1.6.1	DC Source Voltage	9055	0.0	3.4e+38	0.0	V	0.1	Process	REAL
1.6.2	DC Source Current	9000	0.0	3.4e+38	0.0	A	1	Process	REAL
1.6.3	DC Source Power	9043	-3.4e+38	3.4e+38	0.0	kW	1	Process	REAL
1.6.4	DC Source Power %	275	-300.0	300.0	0.0	%	0.1	Process	REAL
1.6.5	DC Source Current %	9001	0.0	200.0	0.0	%	0.01	Process	REAL

6.2.6 DC-link Monitoring

Index	Name	Number	Min	Max	Default	Unit	Reso	Handling Type	Data type
1.7.1	DC-link Voltage	9044	0.0	3.4e+38	0.0	V	0.1	Process	REAL
1.7.2	DC-link Voltage %	6542	0.0	200.0	0.0	%	0.1	Process	REAL
1.7.3	DC-link Current	5115	-6000.0	6000.0	0.0	A	1	Process	REAL
1.7.4	DC-link Current %	5116	-300.0	300.0	0.0	%	0.01	Process	REAL

6.2.7 Converter Control Monitoring

Index	Name	Number	Min	Max	Default	Unit	Reso	Handling Type	Data type
1.8.1	Actual Switching Frequency	2923	0.0	16000.0	0.0	Hz	0.01	Process	REAL
1.8.2	Modulation Index	5101	0.0	2.0	0.0		0.01	Process	REAL
1.8.3	Control Unit Temperature	2952	-50.0	200.0	0.0	°C	0.1	Process	REAL

6.2.8 Protection Monitoring

6.2.8.1 Measured Temp. Protection Status

Index	Name	Number	Min	Max	Default	Unit	Reso	Handling Type	Data type
1.9.1.1	Protection 1 Temp.	5200	-300.0	300.0	0.0	°C	0.01	Process	REAL
1.9.1.2	Protection 2 Temp.	5201	-300.0	300.0	0.0	°C	0.01	Process	REAL
1.9.1.3	Protection 3 Temp.	5202	-300.0	300.0	0.0	°C	0.01	Process	REAL
1.9.1.4	Protection 4 Temp.	5203	-300.0	300.0	0.0	°C	0.01	Process	REAL
1.9.1.5	Protection 5 Temp.	5204	-300.0	300.0	0.0	°C	0.01	Process	REAL
1.9.1.6	Protection 6 Temp.	5205	-300.0	300.0	0.0	°C	0.01	Process	REAL
1.9.1.7	Protection 7 Temp.	5273	-300.0	300.0	0.0	°C	0.01	Process	REAL
1.9.1.8	Protection 8 Temp.	5274	-300.0	300.0	0.0	°C	0.01	Process	REAL
1.9.1.9	Protection 9 Temp.	5275	-300.0	300.0	0.0	°C	0.01	Process	REAL
1.9.1.10	Protection 10 Temp.	5276	-300.0	300.0	0.0	°C	0.01	Process	REAL

6.2.8.2 Supervision Monitoring

Index	Name	Number	Min	Max	Default	Unit	Reso	Handling Type	Data type
1.10.1	Custom Status Word	2410	0x0	0xffff	0x0		1	Process	WORD

6.2.9 Custom Status Word Monitoring

Index	Name	Number	Min	Max	Default	Unit	Reso	Handling Type	Data type
1.10.1	Custom Status Word	2410	0x0	0xffff	0x0		1	Process	WORD

6.2.10 Power Unit Monitoring

Index	Name	Number	Min	Max	Default	Unit	Reso	Handling Type	Data type
1.11.1	Power Capacity	2836	-3.4e+38	100.0	100.0	%	1	Process	REAL
1.11.2	Unit Nominal Voltage	2830	0.0	3.4e+38	400.0	V	0.01	Configuration	REAL
1.11.3	Unit Nominal Current	2831	0.0	3.4e+38	23.0	A	0.01	Configuration	REAL
1.11.4	Heat Sink Temperature	2950	-50.0	200.0	0.0	°C	0.1	Process	REAL

6.2.11 Cooling Fan Monitoring

Index	Name	Number	Min	Max	Default	Unit	Reso	Handling Type	Data type
1.12.1	Main Fan Speed	2931	0	32767	0	rpm	1	Process	INT
1.12.2	Internal Fan Speed	2926	0	32767	0	rpm	1	Process	INT

6.2.12 Fieldbus Process Data Status

Index	Name	Number	Min	Max	Default	Unit	Reso	Handling Type	Data type
1.13.1	Fieldbus Control Word	1335	0x0	0xffff	0x4		1	Process	WORD
1.13.2	Fieldbus Status Word	1307	0x0	0xffff	0x0		1	Process	WORD
1.13.3	DC/DC Control Word	9076	0x0	0xffff	0x0		1	Process	WORD
1.13.4	FB DC-link Voltage Ref.	6533	100.0	150.0	105.0	%	0.1	Process	REAL
1.13.5	FB DC Source Current Ref.	1261	-300.0	300.0	0.0	%	1	Process	REAL
1.13.6	FB DC Source Current Limit Pos.	1262	0.0	300.0	0.0	%	1	Process	REAL
1.13.7	FB DC Source Current Limit Neg.	1263	-300.0	0.0	0.0	%	1	Process	REAL
1.13.8	FB DC Source Voltage Ref.	1264	0.0	1000.0	100.0	%	1	Process	REAL
1.13.9	FB DC Source Power Limit Neg.	1265	-300.0	0.0	-300.0	%	1	Process	REAL
1.13.10	FB DC Source Power Limit Pos.	1266	0.0	300.0	300.0	%	1	Process	REAL
1.13.11	FB Overvoltage Limit	4512	0.0	320.0	120.0	%	0.1	Process	REAL
1.13.12	FB Undervoltage Limit	4510	0.0	320.0	80.0	%	0.1	Process	REAL
1.13.13	FB Output Current Limit	1511	0.0	300.0	0.0	%	1	Process	REAL
1.13.14	FB DC-link Current Ref.	6139	-300.0	300.0	0.0	%	0.01	Process	REAL
1.13.15	FB DC Source Power Ref.	270	-300.0	300.0	0.0	%	0.1	Process	REAL

6.2.13 I/O and Relay Status

Index	Name	Number	Min	Max	Default	Unit	Reso	Handling Type	Data type
9.3.1	Digital Input Bit Word	1614	0x0	0xffff	0x0		1	Process	WORD
9.3.2	Digital Output Bit Word	1615	0x0	0xffff	0x0		1	Process	WORD
9.3.3	T31 Analog Output Value	1613	-20.0	20.0	0.0		0.01	Process	REAL
9.3.4	T33 Analog Input Value	1611	-20.0	20.0	0.0		0.01	Process	REAL
9.3.5	T34 Analog Input Value	1612	-20.0	20.0	0.0		0.01	Process	REAL

6.2.14 Temperature Measurement Status

Index	Name	Number	Min	Max	Default	Unit	Reso	Handling Type	Data type
9.3.2	T4 Temperature Value	4040	-1000.0	1000.0	0.0	°C	1	Process	REAL
9.3.3	T8 Temperature Value	4041	-1000.0	1000.0	0.0	°C	1	Process	REAL
9.3.4	T12 Temperature Value	4042	-1000.0	1000.0	0.0	°C	1	Process	REAL
9.3.5	T16 Temperature Value	4043	-1000.0	1000.0	0.0	°C	1	Process	REAL
9.3.6	T20 Temperature Value	4044	-1000.0	1000.0	0.0	°C	1	Process	REAL

6.2.15 Voltage Measurement

6.3 Parameters

6.3.1 Basic Parameters

Index	Name	Number	Min	Max	Default	Unit	Reso	Handling Type	Data type
2.1.1	DC Source Nominal Voltage	2945	0.0	3.4e+38	620.0	V	0.1	Configuration	REAL
2.1.2	DC Source Nominal Current	2946	-3.4e+38	3.4e+38	25.0	A	0.01	Configuration	REAL
2.1.3	DC-link Nominal Voltage	2834	0.0	1500.0	0.0	V	0.1	Configuration	REAL
2.1.4	Unit Voltage Class	2832	1	4	1		1	Configuration	UINT
2.1.5	Overload Mode	2833	0	3	2		1	Configuration	UINT
2.1.6	Current/Power Positive Direction	2947	0	1	0		1	Configuration	UINT

6.3.2 Control Mode and References

6.3.2.1 Control Mode

Index	Name	Number	Min	Max	Default	Unit	Reso	Handling Type	Data type
2.2.1.1	Operation Mode	2504	0	3	3		1	Configuration	UINT
2.2.1.2	Converter Reference Mode	163	0	1	0		1	Configuration	UINT

6.3.2.2 DC Source Voltage Reference

Index	Name	Number	Min	Max	Default	Unit	Reso	Handling Type	Data type
2.2.2.1	DC Source Voltage Ref. Source	5088	0	1	0		1	Configuration	UINT
2.2.2.2	DC Source Voltage Ref.	5089	0.0	300.0	100.0	%	0.01	Configuration	REAL
2.2.2.3	DC Source Voltage Drooping Gain	5090	0.0	1000.0	0.0	%	0.01	Configuration	REAL
2.2.2.4	DC Source Voltage Ref. Filter Tc	6522	0.0001	100.0	0.05	s	0.01	Configuration	REAL
2.2.2.5	DC Source Voltage Drooping Tc	6523	0.0	10000.0	0.05	s	0.01	Configuration	REAL

6.3.2.3 DC Source Current Reference

Index	Name	Number	Min	Max	Default	Unit	Reso	Handling Type	Data type
2.2.3.1	DC Source Current Ref. Source	240	0	2	0		1	Configuration	UINT
2.2.3.2	DC Source Current Ref.	241	-300.0	300.0	0.0	%	0.01	Configuration	REAL
2.2.3.3	DC Source Current Ref. Tc	242	0.0	100.0	0.05	s	0.001	Configuration	REAL
2.2.3.4	DC Source Current Ref. AI Term.	243	0	29999	0		1	Configuration	UINT
2.2.3.5	DC Source Current Ref. AI Max.	244	-300.0	300.0	100.0	%	0.01	Configuration	REAL
2.2.3.6	DC Source Current Ref. AI Min.	246	-300.0	300.0	-100.0	%	0.01	Configuration	REAL

6.3.2.4 DC Source Power Reference

Index	Name	Number	Min	Max	Default	Unit	Reso	Handling Type	Data type
2.2.4.1	DC Source Power Ref. Source	271	0	2	0		1	Configuration	UINT
2.2.4.2	DC Source Power Ref.	272	-300.0	300.0	0.0	%	0.1	Configuration	REAL
2.2.4.3	DC Source Power Ref. AI Term.	274	0	29999	0		1	Configuration	UINT
2.2.4.4	DC Source Power Ref. AI Max.	276	-300.0	300.0	100.0	%	0.01	Configuration	REAL
2.2.4.5	DC Source Power Ref. AI Min.	277	-300.0	300.0	-100.0	%	0.01	Configuration	REAL

6.3.2.5 DC-link Voltage Reference

Index	Name	Number	Min	Max	Default	Unit	Reso	Handling Type	Data type
2.2.5.1	DC-link Voltage Ref. Source	2916	0	1	0		1	Configuration	UINT
2.2.5.2	DC-link Voltage Ref.	2910	100.0	150.0	105.0	%	0.1	Configuration	REAL
2.2.5.3	DC-link Voltage Ref. Offset	2914	-20.0	20.0	0.0	%	0.01	Configuration	REAL
2.2.5.4	DC-link Voltage Droop Gain	2912	0.0	10.0	0.0	%	0.01	Configuration	REAL
2.2.5.5	DC-link Voltage Ramp Rate	2893	-1.0	1000.0	10.0	PercentPerSecond	0.01	Configuration	REAL
2.2.5.6	DC-link Voltage Ref. Filter Tc	2894	0.0	1.0	0.05	s	0.01	Configuration	REAL

6.3.2.6 DC-link Current Reference

Index	Name	Number	Min	Max	Default	Unit	Reso	Handling Type	Data type
2.2.6.1	DC-link Current Ref. Source	6138	0	1	0		1	Configuration	UINT
2.2.6.2	DC-link Current Ref.	6136	-300.0	300.0	0.0	%	0.01	Configuration	REAL
2.2.6.3	DC-link Current Ref. Filter Tc	6140	0.001	1.0	0.05	s	1	Configuration	REAL
2.2.6.4	DC-Link Current Droop Curve U	5302	0.0	200.0	[100,100,100,100]	%	0.01	Configuration	REAL
2.2.6.5	DC-link Current Droop Curve I	5301	-300.0	300.0	[0,0,0,0]	%	0.01	Configuration	REAL
2.2.6.6	DC-Link Current Droop Curve G	5300	0.0	100.0	[0,0,0,0]		0.01	Configuration	REAL

6.3.3 Limits

6.3.3.1 DC Source Voltage Limits

Index	Name	Number	Min	Max	Default	Unit	Reso	Handling Type	Data type
2.3.1.1	Min. DC Source Voltage Limit	2960	0.0	1000.0	90.0	%	0.01	Configuration	REAL
2.3.1.2	Max. DC Source Voltage Limit	2961	0.0	1000.0	105.0	%	0.01	Configuration	REAL

6.3.3.2 DC Source Current Limits

Index	Name	Number	Min	Max	Default	Unit	Reso	Handling Type	Data type
2.3.2.1	Current Limit Source	2852	0	1	0		1	Configuration	UINT
2.3.2.2	Current Limit	2851	0.0	1000.0	300.0	%	0.01	Configuration	REAL
2.3.2.3	Neg. DC Source Current Limit Source	2859	0	2	0		1	Configuration	UINT
2.3.2.4	Neg. DC Source Current Limit	2860	-1000.0	0.0	-300.0	%	0.01	Configuration	REAL
2.3.2.5	Neg. DC Source Current Limit AI Term.	2974	0	29999	0		1	Configuration	UINT
2.3.2.6	Neg. DC Source Current Limit AI Max.	2975	-300.0	0.0	0.0	%	0.01	Configuration	REAL
2.3.2.7	Neg. DC Source Current Limit AI Min.	2976	-300.0	0.0	-300.0	%	0.01	Configuration	REAL
2.3.2.8	Neg. DC Source Current Limit Ramp Rate	2886	0.0	10000.0	100.0	PercentPerSecond	0.1	Configuration	REAL
2.3.2.9	Pos. DC Source Current Limit Source	2890	0	2	0		1	Configuration	UINT
2.3.2.10	Pos. DC Source Current Limit	2891	0.0	1000.0	300.0	%	0.01	Configuration	REAL
2.3.2.11	Pos. DC Source Current Limit AI Term.	2971	0	29999	0		1	Configuration	UINT
2.3.2.12	Pos. DC Source Current Limit AI Max.	2972	0.0	300.0	300.0	%	0.01	Configuration	REAL
2.3.2.13	Pos. DC Source Current Limit AI Min.	2973	0.0	300.0	0.0	%	0.01	Configuration	REAL
2.3.2.14	Pos. DC Source Current Limit Ramp Rate	2887	0.0	10000.0	100.0	PercentPerSecond	0.1	Configuration	REAL

6.3.3.3 DC Source Power Limits

Index	Name	Number	Min	Max	Default	Unit	Reso	Handling Type	Data type
2.3.3.1	Neg. DC Source Power Limit Source	2870	0	2	0		1	Configuration	UINT
2.3.3.2	DC Source Power Limit Neg.	2872	-300.0	0.0	-300.0	%	0.01	Configuration	REAL
2.3.3.3	Neg. DC Source Power Limit AI Term.	2980	0	29999	0		1	Configuration	UINT
2.3.3.4	Neg. DC Source Power Limit AI Max.	2981	-300.0	0.0	0.0	%	0.01	Configuration	REAL
2.3.3.5	Neg. DC Source Power Limit AI Min.	2982	-300.0	0.0	-300.0	%	0.01	Configuration	REAL
2.3.3.6	Neg. DC Source Power Limit Ramp Rate	2899	-1.0	10000.0	100.0	PercentPerSecond	0.1	Configuration	REAL
2.3.3.7	Pos. DC Source Power Limit Source	2892	0	2	0		1	Configuration	UINT
2.3.3.8	DC Source Power Limit Pos.	2896	0.0	300.0	300.0	%	0.01	Configuration	REAL
2.3.3.9	Pos. DC Source Power Limit AI Term.	2977	0	29999	0		1	Configuration	UINT
2.3.3.10	Pos. DC Source Power Limit AI Max.	2978	0.0	300.0	300.0	%	0.01	Configuration	REAL
2.3.3.11	Pos. DC Source Power Limit AI Min.	2979	0.0	300.0	0.0	%	0.01	Configuration	REAL
2.3.3.12	Pos. DC Source Power Limit Ramp Rate	2908	-1.0	10000.0	100.0	PercentPerSecond	0.1	Configuration	REAL

6.3.3.4 DC-link Voltage Limiters

6.3.3.4.1 Undervoltage Limit Controller

Index	Name	Number	Min	Max	Default	Unit	Reso	Handling Type	Data type
2.3.4.1.1	Undervoltage Control	1809	0	1	1		1	Configuration	BOOL
2.3.4.1.2	Undervoltage Limit Source	2900	0	1	0		1	Configuration	UINT
2.3.4.1.3	Undervoltage Limit	2901	0.0	320.0	80.0	%	0.1	Configuration	REAL

6.3.3.4.2 Overvoltage Limit Controller

Index	Name	Number	Min	Max	Default	Unit	Reso	Handling Type	Data type
2.3.4.2.1	Overvoltage Control	1802	0	1	1		1	Configuration	BOOL
2.3.4.2.2	Overvoltage Limit Source	2897	0	1	0		1	Configuration	UINT
2.3.4.2.3	Overvoltage Limit	2898	0.0	320.0	120.0	%	0.1	Configuration	REAL

6.3.4 Digital and Analog Inputs

6.3.4.1 Digital Inputs

Index	Name	Number	Min	Max	Default	Unit	Reso	Handling Type	Data type
2.4.1.1	Run Enable Input	103	0	29999	1		1	Configuration	UINT
2.4.1.2	External Event 1 Input	4557	0	29999	0		1	Configuration	UINT
2.4.1.3	External Event 2 Input	4560	0	29999	0		1	Configuration	UINT
2.4.1.4	Cooling Monitor Input	2400	0	29999	1		1	Configuration	UINT
2.4.1.5	Force I/O Control Input	4513	0	29999	0		1	Configuration	UINT
2.4.1.6	Force FB Control Input	4511	0	29999	0		1	Configuration	UINT
2.4.1.7	I/O Start Input	200	0	29999	0		1	Configuration	UINT
2.4.1.8	I/O Stop Input	201	0	29999	1		1	Configuration	UINT
2.4.1.9	I/O Reset Input	203	0	29999	0		1	Configuration	UINT
2.4.1.10	Quick Stop Input	212	0	29999	1		1	Configuration	UINT
2.4.1.11	Quick Stop Input 2	5104	0	29999	1		1	Configuration	UINT

6.3.4.2 Analog Inputs

Index	Name	Number	Min	Max	Default	Unit	Reso	Handling Type	Data type
2.4.2.1	DC Source Current Ref. AI Term.	243	0	29999	0		1	Configuration	UINT
2.4.2.2	DC Source Power Ref. AI Term.	274	0	29999	0		1	Configuration	UINT
2.4.2.3	Neg. DC Source Current Limit AI Term.	2974	0	29999	0		1	Configuration	UINT
2.4.2.4	Pos. DC Source Current Limit AI Term.	2971	0	29999	0		1	Configuration	UINT
2.4.2.5	Neg. DC Source Power Limit AI Term.	2980	0	29999	0		1	Configuration	UINT
2.4.2.6	Pos. DC Source Power Limit AI Term.	2977	0	29999	0		1	Configuration	UINT

6.3.5 Digital and Analog Outputs

6.3.5.1 Digital Outputs

Index	Name	Number	Min	Max	Default	Unit	Reso	Handling Type	Data type
2.5.1.1	Ready Output	205	0	29999	0		1	Configuration	UINT
2.5.1.2	Run Output	206	0	29999	0		1	Configuration	UINT
2.5.1.3	Static Fault Output	208	0	29999	0		1	Configuration	UINT
2.5.1.4	Static Warning Output	209	0	29999	0		1	Configuration	UINT
2.5.1.5	Toggling Fault Output	5180	0	29999	0		1	Configuration	UINT
2.5.1.6	Toggling Warning Output	5181	0	29999	0		1	Configuration	UINT
2.5.1.7	FB CTW Bit 12 Output	5193	0	29999	0		1	Configuration	UINT

Index	Name	Number	Min	Max	Default	Unit	Reso	Handling Type	Data type
2.5.1.8	FB CTW Bit 13 Output	5194	0	29999	0		1	Configuration	UINT
2.5.1.9	FB CTW Bit 14 Output	5198	0	29999	0		1	Configuration	UINT
2.5.1.10	FB CTW Bit 15 Output	5191	0	29999	0		1	Configuration	UINT
2.5.1.11	DC-link Voltage Superv. Output	5157	0	29999	0		1	Configuration	UINT
2.5.1.12	DC-link Voltage Superv. Limit	5158	0.0	1500.0	100.0	V	0.01	Configuration	REAL
2.5.1.13	Local Control Active Output	5178	0	29999	0		1	Configuration	UINT
2.5.1.14	I/O Control Active Output	5177	0	29999	0		1	Configuration	UINT
2.5.1.15	Fieldbus Control Active Output	5197	0	29999	0		1	Configuration	UINT
2.5.1.16	Active Exception 1 Output	5189	0	29999	0		1	Configuration	UINT
2.5.1.17	Event 1 Number	5188	0	65535	0		1	Configuration	UINT
2.5.1.18	Active Event 2 Output	5190	0	29999	0		1	Configuration	UINT
2.5.1.19	Event 2 Number	5290	0	65535	0		1	Configuration	UINT
2.5.1.20	No Warning Output	217	0	29999	0		1	Configuration	UINT
2.5.1.21	No Fault Output	218	0	29999	0		1	Configuration	UINT
2.5.1.22	Local Control Forcing Requested Output	125	0	29999	0		1	Configuration	UINT
2.5.1.23	I/O Forcing Requested Output	121	0	29999	0		1	Configuration	UINT
2.5.1.24	FB Forcing Requested Output	120	0	29999	0		1	Configuration	UINT
2.5.1.25	DC Source Voltage Monitoring Output	5160	0	29999	0		1	Configuration	UINT
2.5.1.26	DC Source Voltage Monitoring Level	5159	0.0	1500.0	100.0	V	1	Configuration	REAL
2.5.1.27	Source Charging Output	5595	0	29999	0		1	Configuration	UINT
2.5.1.28	Source Discharging Output	5543	0	29999	0		1	Configuration	UINT

6.3.5.2 Delayed Digital Outputs

Index	Name	Number	Min	Max	Default	Unit	Reso	Handling Type	Data type
2.5.2.1	Delayed Output 1 Content Sel.	8032	0	14	0		1	Configuration	UINT
2.5.2.2	Delayed Output 1 On Delay	8036	0.0	320.0	0.0	s	0.01	Configuration	REAL
2.5.2.3	Delayed Output 1 Off Delay	8038	0.0	320.0	0.0	s	0.01	Configuration	REAL
2.5.2.4	Delayed Output 1 Output	8040	0	29999	0		1	Configuration	UINT
2.5.2.5	Delayed Output 2 Content Sel.	8033	0	14	0		1	Configuration	UINT
2.5.2.6	Delayed Output 2 On Delay	8037	0.0	320.0	0.0	s	0.01	Configuration	REAL
2.5.2.7	Delayed Output 2 Off Delay	8039	0.0	320.0	0.0	s	0.01	Configuration	REAL
2.5.2.8	Delayed Output 2 Output	8041	0	29999	0		1	Configuration	UINT

6.3.5.3 Analog Outputs

Index	Name	Number	Min	Max	Default	Unit	Reso	Handling Type	Data type
2.5.3.1	DC-link Voltage Output	2454	0	29999	0		1	Configuration	UINT
2.5.3.2	DC-link Voltage Output Max.	2460	50.0	150.0	120.0	%	1	Configuration	REAL
2.5.3.3	DC-link Voltage Output Min.	2461	0.0	100.0	0.0	%	1	Configuration	REAL
2.5.3.4	DC-link Current Output	2465	0	29999	0		1	Configuration	UINT
2.5.3.5	DC-link Current Output Max.	2466	0.0	300.0	100.0	%	1	Configuration	REAL
2.5.3.6	DC-link Current Output Min.	2467	-300.0	0.0	-100.0	%	1	Configuration	REAL
2.5.3.7	Source Current Output	5996	0	29999	0		1	Configuration	UINT
2.5.3.8	Source Current Output Min.	5992	-300.0	0.0	0.0	%	1	Configuration	REAL
2.5.3.9	Source Current Output Max.	5999	0.0	300.0	100.0	%	1	Configuration	REAL
2.5.3.10	Source Voltage Output	6999	0	29999	0		1	Configuration	UINT
2.5.3.11	Source Voltage Output Max.	7998	0.0	100.0	100.0	%	1	Configuration	REAL
2.5.3.12	Source Voltage Output Min.	8998	0.0	100.0	0.0	%	1	Configuration	REAL
2.5.3.13	Source Power Output	6968	0	29999	0		1	Configuration	UINT
2.5.3.14	Source Power Output Min.	6969	-300.0	0.0	-100.0	%	1	Configuration	REAL
2.5.3.15	Source Power Output Max.	6970	0.0	300.0	100.0	%	1	Configuration	REAL

6.3.6 Start and Stop Settings

6.3.6.1 Start Settings

Index	Name	Number	Min	Max	Default	Unit	Reso	Handling Type	Data type
2.6.1.1	Start Delay	4718	0.0	10.0	0.0	s	0.1	Configuration	REAL
2.6.1.2	Run Enable Input	103	0	29999	1		1	Configuration	UINT

6.3.6.2 Stop Settings

Index	Name	Number	Min	Max	Default	Unit	Reso	Handling Type	Data type
2.6.2.1	Stop Ramp Time	2970	0.0	10000.0	0.1	s	0.01	Configuration	REAL

6.3.6.3 Quick Stop

Index	Name	Number	Min	Max	Default	Unit	Reso	Handling Type	Data type
2.6.3.1	Quick Stop Input	212	0	29999	1		1	Configuration	UINT
2.6.3.2	Quick Stop Input 2	5104	0	29999	1		1	Configuration	UINT
2.6.3.3	Quick Stop Response	4587	0	10	10		1	Configuration	UINT

6.3.7 Control Places

6.3.7.1 Control Place Settings

Index	Name	Number	Min	Max	Default	Unit	Reso	Handling Type	Data type
2.7.1.1	Control Place Selection	114	1	3	3		1	Configuration	UINT
2.7.1.2	Force FB Control Input	4511	0	29999	0		1	Configuration	UINT
2.7.1.3	Force I/O Control Input	4513	0	29999	0		1	Configuration	UINT
2.7.1.4	Control Place Forcing Mode	1972	0	3	0		1	Configuration	UINT
2.7.1.5	Control Place Independent Reset	109	0	1	0		1	Configuration	BOOL
2.7.1.6	Control Place Release Mode	4800	0	1	1		1	Configuration	BOOL
2.7.1.7	Control Place Forcing Priority	4732	1	3	[1,3,2]		1	Configuration	UINT

6.3.7.2 Local Control

Index	Name	Number	Min	Max	Default	Unit	Reso	Handling Type	Data type
2.7.2.1	Local Control Mode	107	0	2	0		1	Configuration	UINT
2.7.2.2	Continue Operation in Local Control	108	0	1	0		1	Configuration	BOOL

6.3.7.3 I/O Control

Index	Name	Number	Min	Max	Default	Unit	Reso	Handling Type	Data type
2.7.3.1	I/O Start Input	200	0	29999	0		1	Configuration	UINT
2.7.3.2	I/O Stop Input	201	0	29999	1		1	Configuration	UINT
2.7.3.3	I/O Reset Input	203	0	29999	0		1	Configuration	UINT
2.7.3.4	I/O Start Mode	213	0	2	0		1	Configuration	UINT
2.7.3.5	Continue Operation in I/O Control	5111	0	1	0		1	Configuration	BOOL

6.3.7.4 Fieldbus Control

Index	Name	Number	Min	Max	Default	Unit	Reso	Handling Type	Data type
2.7.4.1	Continue Operation in Fieldbus Control	5112	0	1	0		1	Configuration	BOOL
2.7.4.2	Fieldbus Start Mode	5114	0	1	1		1	Configuration	UINT

6.3.8 Converter Control

6.3.8.1 Modulation

Index	Name	Number	Min	Max	Default	Unit	Reso	Handling Type	Data type
2.8.1.1	Switching Frequency	2920	-	16777216.0	1000.0	kHz	0.01	Configuration	REAL
2.8.1.2	Modulator Options	5093	0x0	0xffff	0x0		1	Configuration	WORD
2.8.1.3	Forward Voltage Compensation	6518	0.0	1000.0	100.0	%	0.01	Configuration	REAL

6.3.8.2 Advanced DC Source Control

Index	Name	Number	Min	Max	Default	Unit	Reso	Handling Type	Data type
2.8.2.1	Current Controller Kp	8021	0.0	1e+05	100.0	%	0.01	Configuration	REAL
2.8.2.2	Current Controller Ti	8022	0.1	1e+05	100.0	%	0.01	Configuration	REAL
2.8.2.3	DC Source Voltage Control Kp	6526	0.001	1000.0	100.0	%	0.01	Configuration	REAL
2.8.2.4	DC Source Voltage Control Ti	6527	0.0	1000.0	100.0	%	0.01	Configuration	REAL
2.8.2.5	DC Source Voltage Control Td	6575	0.0	1000.0	100.0	%	0.01	Configuration	REAL

6.3.8.3 Advanced DC-link Control

Index	Name	Number	Min	Max	Default	Unit	Reso	Handling Type	Data type
2.8.3.1	DC-link Voltage Ctrl. Kp	2902	0.0	1000.0	100.0	%	0.01	Configuration	REAL
2.8.3.2	DC-link Voltage Ctrl. Ti	2903	0.0	1000.0	100.0	%	0.01	Configuration	REAL
2.8.3.3	DC-link Voltage Ctrl. Td	2907	0.0	1000.0	100.0	%	0.01	Configuration	REAL
2.8.3.4	DC-link Voltage Droop. Tc	5095	0.0	1.0	0.05	s	0.01	Configuration	REAL
2.8.3.8	Overvoltage Control Kp	1803	0.0	10000.0	100.0	%	0.01	Configuration	REAL
2.8.3.9	Overvoltage Control Ti	1804	0.0	10000.0	100.0	%	0.01	Configuration	REAL
2.8.3.10	Overvoltage Control Td	1805	0.0	10000.0	100.0	%	0.01	Configuration	REAL
2.8.3.11	Undervoltage Control Kp	1806	0.001	10000.0	100.0	%	0.01	Configuration	REAL
2.8.3.12	Undervoltage Control Ti	1807	0.0	10000.0	100.0	%	0.01	Configuration	REAL
2.8.3.13	Undervoltage Control Td	1808	0.0	10000.0	100.0	%	0.01	Configuration	REAL

6.3.8.4 Power Unit Settings

Index	Name	Number	Min	Max	Default	Unit	Reso	Handling Type	Data type
2.8.4.1	Power Unit Enable Mask	2835	0x0	0xffff	0xffff		1	Configuration	WORD
2.8.4.2	DC-link Voltage Measurement Corr. Gain	6535	-1.0	1.0	0.0	%	0.01	Configuration	REAL
2.8.4.3	DC-link Voltage Measurement Corr. Offset	6534	-5.0	5.0	0.0	V	0.01	Configuration	REAL
2.8.4.4	HF DC-link Filter Mode	2944	0	2	2		1	Configuration	UINT

6.3.8.5 Cooling Fan Control

Index	Name	Number	Min	Max	Default	Unit	Reso	Handling Type	Data type
2.8.5.1	Main Fan Minimum Speed	2932	0.0	100.0	0.0	%	0.01	Configuration	REAL
2.8.5.2	Internal Fan Minimum Speed	2928	0.0	100.0	0.0	%	1	Configuration	REAL

6.3.8.6 LCL-Filter

Index	Name	Number	Min	Max	Default	Unit	Reso	Handling Type	Data type
2.8.6.1	LCL Filter L1	2904	0.0	1.0	0.000104	μH	0.01	Configuration	REAL
2.8.6.2	LCL Filter Cf	2905	0.0	1.0	0.0000825	μF	0.01	Configuration	REAL

Index	Name	Number	Min	Max	Default	Unit	Reso	Handling Type	Data type
2.8.6.3	LCL Filter R1	6521	0.0	1e+06	0.0	mΩ	0.0001	Configuration	REAL

6.3.9 Protections and Responses

6.3.9.1 General Settings

Index	Name	Number	Min	Max	Default	Unit	Reso	Handling Type	Data type
2.9.1.1	Retry after Fault	2927	0	1	1		1	Configuration	BOOL

6.3.9.2 Misc. Responses

Index	Name	Number	Min	Max	Default	Unit	Reso	Handling Type	Data type
2.9.2.1	DC-link Voltage Ripple Response	2929	0	2	1		1	Configuration	UDINT
2.9.2.2	LCL Fan Fail Response	2941	0	10	10		1	Configuration	UINT

6.3.9.3 External Event

Index	Name	Number	Min	Max	Default	Unit	Reso	Handling Type	Data type
2.9.3.1	External Event 1 Input	4557	0	29999	0		1	Configuration	UINT
2.9.3.2	External Event 1 Response	4559	0	10	10		1	Configuration	UINT
2.9.3.3	External Event 2 Input	4560	0	29999	0		1	Configuration	UINT
2.9.3.4	External Event 2 Response	4562	0	10	10		1	Configuration	UINT

6.3.9.4 Cooling Monitor

Index	Name	Number	Min	Max	Default	Unit	Reso	Handling Type	Data type
2.9.4.1	Cooling Monitor Input	2400	0	29999	1		1	Configuration	UINT
2.9.4.2	Cooling Monitor Fault Delay	2401	0.0	300.0	10.0	s	0.01	Configuration	REAL
2.9.4.3	Cooling Monitor Response	2402	0	3	0		1	Configuration	UINT

6.3.9.5 Measured Temp. Protection

6.3.9.5.1 Temp. 1 Protection

Index	Name	Number	Min	Max	Default	Unit	Reso	Handling Type	Data type
2.9.5.1.1	Temp. 1 Input	5206	0	29999	0		1	Configuration	UINT
2.9.5.1.2	Temp. 1 Limit 1	5207	-300.0	300.0	120.0	°C	0.01	Configuration	REAL
2.9.5.1.3	Temp. 1 Limit 2	5208	-300.0	300.0	150.0	°C	0.01	Configuration	REAL
2.9.5.1.4	Temp. 1 Limit 2 Response	5209	3	11	11		1	Configuration	UINT

6.3.9.5.2 Temp. 2 Protection

Index	Name	Number	Min	Max	Default	Unit	Reso	Handling Type	Data type
2.9.5.2.1	Temp. 2 Input	5210	0	29999	0		1	Configuration	UINT
2.9.5.2.2	Temp. 2 Limit 1	5211	-300.0	300.0	120.0	°C	0.01	Configuration	REAL
2.9.5.2.3	Temp. 2 Limit 2	5212	-300.0	300.0	150.0	°C	0.01	Configuration	REAL
2.9.5.2.4	Temp. 2 Limit 2 Response	5213	3	11	11		1	Configuration	UINT

6.3.9.5.3 Temp. 3 Protection

Index	Name	Number	Min	Max	Default	Unit	Reso	Handling Type	Data type
2.9.5.3.1	Temp. 3 Input	5214	0	29999	0		1	Configuration	UINT
2.9.5.3.2	Temp. 3 Limit 1	5215	-300.0	300.0	120.0	°C	0.01	Configuration	REAL
2.9.5.3.3	Temp. 3 Limit 2	5216	-300.0	300.0	150.0	°C	0.01	Configuration	REAL
2.9.5.3.4	Temp. 3 Limit 2 Response	5217	3	11	11		1	Configuration	UINT

6.3.9.5.4 Temp. 4 Protection

Index	Name	Number	Min	Max	Default	Unit	Reso	Handling Type	Data type
2.9.5.4.1	Temp. 4 Input	5218	0	29999	0		1	Configuration	UINT
2.9.5.4.2	Temp. 4 Limit 1	5219	-300.0	300.0	120.0	°C	0.01	Configuration	REAL
2.9.5.4.3	Temp. 4 Limit 2	5220	-300.0	300.0	150.0	°C	0.01	Configuration	REAL
2.9.5.4.4	Temp. 4 Limit 2 Response	5221	3	11	11		1	Configuration	UINT

6.3.9.5.5 Temp. 5 Protection

Index	Name	Number	Min	Max	Default	Unit	Reso	Handling Type	Data type
2.9.5.5.1	Temp. 5 Input	5222	0	29999	0		1	Configuration	UINT
2.9.5.5.2	Temp. 5 Limit 1	5223	-300.0	300.0	120.0	°C	0.01	Configuration	REAL
2.9.5.5.3	Temp. 5 Limit 2	5224	-300.0	300.0	150.0	°C	0.01	Configuration	REAL
2.9.5.5.4	Temp. 5 Limit 2 Response	5225	3	11	11		1	Configuration	UINT

6.3.9.5.6 Temp. 6 Protection

Index	Name	Number	Min	Max	Default	Unit	Reso	Handling Type	Data type
2.9.5.6.1	Temp. 6 Input	5226	0	29999	0		1	Configuration	UINT
2.9.5.6.2	Temp. 6 Limit 1	5227	-300.0	300.0	120.0	°C	0.01	Configuration	REAL
2.9.5.6.3	Temp. 6 Limit 2	5228	-300.0	300.0	150.0	°C	0.01	Configuration	REAL
2.9.5.6.4	Temp. 6 Limit 2 Response	5229	3	11	11		1	Configuration	UINT

6.3.4.1.1 Temp. 7 Protection

Index	Name	Number	Min	Max	Default	Unit	Reso	Handling Type	Data type
2.9.5.7.1	Temp. 7 Input	5239	0	29999	0		1	Configuration	UINT
2.9.5.7.2	Temp. 7 Limit 1	5243	-300.0	300.0	120.0	°C	1	Configuration	REAL
2.9.5.7.3	Temp. 7 Limit 2	5269	-300.0	300.0	150.0	°C	1	Configuration	REAL
2.9.5.7.4	Temp. 7 Limit 2 Response	5235	3	11	11		1	Configuration	UINT

6.3.9.5.7 Temp. 8 Protection

Index	Name	Number	Min	Max	Default	Unit	Reso	Handling Type	Data type
2.9.5.8.1	Temp. 8 Input	5240	0	29999	0		1	Configuration	UINT
2.9.5.8.2	Temp. 8 Limit 1	5247	-300.0	300.0	120.0	°C	1	Configuration	REAL
2.9.5.8.3	Temp. 8 Limit 2	5270	-300.0	300.0	150.0	°C	1	Configuration	REAL
2.9.5.8.4	Temp. 8 Limit 2 Response	5236	3	11	11		1	Configuration	UINT

6.3.9.5.8 Temp. 9 Protection

Index	Name	Number	Min	Max	Default	Unit	Reso	Handling Type	Data type
2.9.5.9.1	Temp. 9 Input	5241	0	29999	0		1	Configuration	UINT
2.9.5.9.2	Temp. 9 Limit 1	5249	-300.0	300.0	120.0	°C	1	Configuration	REAL
2.9.5.9.3	Temp. 9 Limit 2	5271	-300.0	300.0	150.0	°C	1	Configuration	REAL
2.9.5.9.4	Temp. 9 Limit 2 Response	5237	3	11	11		1	Configuration	UINT

6.3.9.5.9 Temp. 10 Protection

Index	Name	Number	Min	Max	Default	Unit	Reso	Handling Type	Data type
2.9.5.10.1	Temp. 10 Input	5242	0	29999	0		1	Configuration	UINT
2.9.5.10.2	Temp. 10 Limit 1	5268	-300.0	300.0	120.0	°C	1	Configuration	REAL
2.9.5.10.3	Temp. 10 Limit 2	5272	-300.0	300.0	150.0	°C	1	Configuration	REAL
2.9.5.10.4	Temp. 10 Limit 2 Response	5238	3	11	11		1	Configuration	UINT

6.3.9.5.10 Common

Index	Name	Number	Min	Max	Default	Unit	Reso	Handling Type	Data type
2.9.5.11.1	Meas. Valid Range	5230	-300.0	300.0	[200,-50]	°C	0.01	Configuration	REAL
2.9.5.11.2	Meas. Out of Range Response	5231	0	11	3		1	Configuration	UINT

6.3.9.6 Thermistor Monitoring

Index	Name	Number	Min	Max	Default	Unit	Reso	Handling Type	Data type
2.9.6.1	Thermistor Monitoring Response	5232	0	11	10		1	Configuration	UINT
2.9.6.2	Thermistor Monitor 1 Input	1520	0	29999	0		1	Configuration	UINT
2.9.6.3	Thermistor Monitor 2 Input	1522	0	29999	0		1	Configuration	UINT
2.9.6.4	Thermistor Monitor 3 Input	1524	0	29999	0		1	Configuration	UINT

6.3.9.7 Live Zero

Index	Name	Number	Min	Max	Default	Unit	Reso	Handling Type	Data type
2.9.7.1	Live Zero Response	4554	0	13	3		1	Configuration	UINT

6.3.9.8 Fieldbus Protections

Index	Name	Number	Min	Max	Default	Unit	Reso	Handling Type	Data type
2.9.8.1	Fieldbus Fault Response	1304	0	13	10		1	Configuration	UINT
2.9.8.2	No Fieldbus Connection Response	1305	0	13	0		1	Configuration	UINT
2.9.8.3	Process Data Timeout Response	1306	1	13	1		1	Configuration	UINT
2.9.8.4	Process Data Timeout Delay	1340	50.0	3.4e+38	1000.0	s	0.01	Configuration	REAL
2.9.8.5	Fieldbus Watchdog Response	5244	0	13	3		1	Configuration	UINT
2.9.8.6	Fieldbus Watchdog Delay	5245	0.0	3000.0	5.0	s	0.01	Configuration	REAL
2.9.8.7	Fieldbus Watchdog Start Delay	5246	0.0	3000.0	30.0	s	0.01	Configuration	REAL

6.3.9.9 HMI Connection Loss

Index	Name	Number	Min	Max	Default	Unit	Reso	Handling Type	Data type
2.9.9.1	HMI Connection Loss	5420	0	11	10		1	Configuration	UINT

6.3.9.10 Cooling Fan Supervision

Index	Name	Number	Min	Max	Default	Unit	Reso	Handling Type	Data type
2.9.10.1	Main Fan Fail Response	2939	0	11	3		1	Configuration	UINT
2.9.10.2	Internal Fan Fail Response	2940	0	11	3		1	Configuration	UINT

6.3.9.11 Voltage Supervision

Index	Name	Number	Min	Max	Default	Unit	Reso	Handling Type	Data type
2.9.11.1	DC Source Voltage Superv. Response	2962	0	3	2		1	Configuration	UINT
2.9.11.2	DC Source Voltage Superv. Delay	2963	0.0	10.0	0.0	s	0.1	Configuration	REAL
2.9.11.3	DC Source Voltage Superv. Margin	2966	0.1	5.0	0.1	%	0.01	Configuration	REAL

6.3.9.12 Current Supervision

Index	Name	Number	Min	Max	Default	Unit	Reso	Handling Type	Data type
2.9.12.1	DC Source Current Superv. Response	2964	0	2	0		1	Configuration	UINT
2.9.12.2	DC Source Current Superv. Delay	2965	0.1	10.0	0.5	s	0.01	Configuration	REAL
2.9.12.3	DC Source Current Superv. Margin	2967	0.1	5.0	0.5	%	0.01	Configuration	REAL

6.4 Maintenance & Service

6.4.1 Software Information

Index	Name	Number	Min	Max	Default	Unit	Reso	Handling Type	Data type
3.1.1	Application Version	151					1	Configuration	STRING

6.4.2 Events

6.4.2.1 Event Simulation

Index	Name	Number	Min	Max	Default	Unit	Reso	Handling Type	Data type
3.2.3.1	Simulate Event	1400	0	10	0		1	Configuration	UINT
3.2.3.2	Simulate Persisting Event	1401	0	10	0		1	Configuration	UINT
3.2.3.3	Simulate Event Number	1402	0	65535	5260		1	Configuration	UINT

6.4.3 Operational Counters

Index	Name	Number	Min	Max	Default	Unit	Reso	Handling Type	Data type
3.3.1	Control Unit On Time	2000	0	4294967295	0	h	1	Configuration	UDINT
3.3.2	Power Unit On Time	2001	0	4294967295	0	h	1	Configuration	UDINT
3.3.3	Energy Consumption	2002	-	-	-	kWh	1	Configuration	ULINT
3.3.4	Overvoltage Faults	2005	0	50000	0		1	Configuration	UINT
3.3.5	Overcurrent Faults	2006	0	50000	0		1	Configuration	UINT
3.3.6	Short Circuit Faults	2007	0	50000	0		1	Configuration	UINT
3.3.7	Number of Starts	2008	0	4294967295	0		1	Configuration	UDINT
3.3.8	Active Running Hours	2009	0	4294967295	0	h	1	Configuration	UDINT
3.3.9	Flash 0 Wear Counter	2100	0	4294967295	0		1	Configuration	UDINT
3.3.10	Flash 1 Wear Counter	2101	0	4294967295	0		1	Configuration	UDINT

6.5 Customization

6.5.1 Basic Settings

Index	Name	Number	Min	Max	Default	Unit	Reso	Handling Type	Data type
5.1.1	Date and Time	2800	-	-	-		1	Configuration	DATE_AND_TIME
5.1.2	Time Mode	6232			1			Configuration	USINT
5.1.3	NTP Server 1	6233						Configuration	STRING
5.1.4	NTP Server 2	6234						Configuration	STRING

6.5.2 Control Panel

6.5.2.1 Readout Screen 1

Index	Name	Number	Min	Max	Default	Unit	Reso	Handling Type	Data type
5.2.1.1	Readout Field 1.1	300	0	4294967295	0		1	Configuration	UDINT
5.2.1.2	Readout Field 1.2	301	0	4294967295	0		1	Configuration	UDINT

Application Guide | iC7 Series Grid Converter

5.2.1.3	Readout Field 1.3	302	0	4294967295	0		1	Configuration	UDINT
5.2.1.4	Readout Field 1.4	303	0	4294967295	0		1	Configuration	UDINT
5.2.1.5	Readout Field 1.5	304	0	4294967295	0		1	Configuration	UDINT

6.5.2.2 Readout Screen 2

Index	Name	Number	Min	Max	Default	Unit	Reso	Handling Type	Data type
5.2.2.1	Readout Field 2.1	310	0	4294967295	9044		1	Process	UDINT
5.2.2.2	Readout Field 2.2	311	0	4294967295	9040		1	Configuration	UDINT
5.2.2.3	Readout Field 2.3	312	0	4294967295	9041		1	Configuration	UDINT
5.2.2.4	Readout Field 2.4	313	0	4294967295	2950		1	Configuration	UDINT
5.2.2.5	Readout Field 2.5	314	0	4294967295	2952		1	Configuration	UDINT

6.5.3 Custom Status Word

Index	Name	Number	Min	Max	Default	Unit	Reso	Handling Type	Data type
5.3.1	Custom Status Word B0	2411	0	65535	100		1	Configuration	UINT
5.3.2	Custom Status Word B1	2412	0	65535	101		1	Configuration	UINT
5.3.3	Custom Status Word B2	2413	0	65535	102		1	Configuration	UINT
5.3.4	Custom Status Word B3	2414	0	65535	103		1	Configuration	UINT
5.3.5	Custom Status Word B4	2415	0	65535	104		1	Configuration	UINT
5.3.6	Custom Status Word B5	2416	0	65535	301		1	Configuration	UINT
5.3.7	Custom Status Word B6	2417	0	65535	302		1	Configuration	UINT
5.3.8	Custom Status Word B7	2418	0	65535	310		1	Configuration	UINT
5.3.9	Custom Status Word B8	2419	0	65535	0		1	Configuration	UINT
5.3.10	Custom Status Word B9	2420	0	65535	0		1	Configuration	UINT
5.3.11	Custom Status Word B10	2421	0	65535	0		1	Configuration	UINT
5.3.12	Custom Status Word B11	2422	0	65535	0		1	Configuration	UINT
5.3.13	Custom Status Word B12	2423	0	65535	0		1	Configuration	UINT
5.3.14	Custom Status Word B13	2424	0	65535	0		1	Configuration	UINT
5.3.15	Custom Status Word B14	2425	0	65535	0		1	Configuration	UINT
5.3.16	Custom Status Word B15	2426	0	65535	0		1	Configuration	UINT

6.6 Option Board Settings

6.6.1 I/O and Relay

6.6.1.1 I/O and Relay Status

Index	Name	Number	Min	Max	Default	Unit	Reso	Handling Type	Data type
9.3.1	Digital Input Bit Word	1614	0x0	0xffff	0x0		1	Process	WORD
9.3.2	Digital Output Bit Word	1615	0x0	0xffff	0x0		1	Process	WORD
9.3.3	T31 Analog Output Value	1613	-20.0	20.0	0.0		0.01	Process	REAL
9.3.4	T33 Analog Input Value	1611	-20.0	20.0	0.0		0.01	Process	REAL
9.3.5	T34 Analog Input Value	1612	-20.0	20.0	0.0		0.01	Process	REAL

6.6.1.2 Digital Inputs/Outputs

6.6.1.2.1 Input T13

Index	Name	Number	Min	Max	Default	Unit	Reso	Handling Type	Data type
9.4.1.1	T13 Terminal Mode	2015	0	3	0		1	Config	UINT
9.4.1.2	T13 Signal Inversion	2291	0	1	0		1	Config	UINT
9.4.1.3	T13 Standard Debounce Filtering Time	2024	0.0	0.1	0.0	ms	1	Config	REAL

6.6.1.2.2 Input T14

Index	Name	Number	Min	Max	Default	Unit	Reso	Handling Type	Data type
9.4.2.1	T14 Terminal Mode	2016	0	3	0		1	Config	UINT
9.4.2.2	T14 Signal Inversion	2292	0	1	0		1	Config	UINT
9.4.2.3	T14 Standard Debounce Filtering Time	2029	0.0	0.1	0.0	ms	1	Config	REAL

6.6.1.2.3 Input T15

Index	Name	Number	Min	Max	Default	Unit	Reso	Handling Type	Data type
9.4.3.1	T15 Terminal Mode	2022	0	3	0		1	Config	UINT
9.4.3.2	T15 Signal Inversion	2295	0	1	0		1	Config	UINT
9.4.3.3	T15 Standard Debounce Filtering Time	2297	0.0	0.1	0.0	ms	1	Config	REAL

6.6.1.2.4 Input T16

Index	Name	Number	Min	Max	Default	Unit	Reso	Handling Type	Data type
9.4.4.1	T16 Terminal Mode	2298	0	3	0		1	Config	UINT
9.4.4.2	T16 Signal Inversion	2296	0	1	0		1	Config	UINT
9.4.4.3	T16 Standard Debounce Filtering Time	2260	0.0	0.1	0.0	ms	1	Config	REAL

6.6.1.2.5 Input T17

Index	Name	Number	Min	Max	Default	Unit	Reso	Handling Type	Data type
9.4.5.1	T17 Terminal Mode	2017	0	3	0		1	Config	UINT
9.4.5.2	T17 Signal Inversion	2293	0	1	0		1	Config	UINT
9.4.5.3	T17 Standard Debounce Filtering Time	2034	0.0	0.1	0.0	ms	1	Config	REAL

6.6.1.2.6 Input T18

Index	Name	Number	Min	Max	Default	Unit	Reso	Handling Type	Data type
9.4.6.1	T18 Terminal Mode	2018	0	3	0		1	Config	UINT
9.4.6.2	T18 Signal Inversion	2294	0	1	0		1	Config	UINT
9.4.6.3	T18 Standard Debounce Filtering Time	2039	0.0	0.1	0.0	ms	1	Config	REAL

6.6.1.2.7 Output T21

Index	Name	Number	Min	Max	Default	Unit	Reso	Handling Type	Data type
9.4.7.1	T21 Terminal Mode	4015	0	1	0		1	Config	UINT
9.4.7.2	T21 Digital Output Type	4013	0	3	3		1	Config	UINT

6.6.1.2.8 Output T22

Index	Name	Number	Min	Max	Default	Unit	Reso	Handling Type	Data type
9.4.8.1	T22 Terminal Mode	4016	0	1	0		1	Config	UINT
9.4.8.2	T22 Digital Output Type	4014	0	3	3		1	Config	UINT

6.6.1.3 Analog Inputs/Outputs

6.6.1.3.1 Output T31

Index	Name	Number	Min	Max	Default	Unit	Reso	Handling Type	Data type
9.5.1.1	T31 Terminal Mode	2019	0	5	0		1	Config	UINT
9.5.1.2	T31 Terminal Type	2284	0	2	1		1	Config	UINT
9.5.1.3	T31 Minimum Value	2283	-20.0	20.0	0.0		0.01	Config	REAL
9.5.1.4	T31 Maximum Value	2282	-20.0	20.0	10.0		0.01	Config	REAL

6.6.1.3.2 Input T33

Index	Name	Number	Min	Max	Default	Unit	Reso	Handling Type	Data type
9.5.2.1	T33 Terminal Mode	2020	0	6	0		1	Config	UINT
9.5.2.2	T33 Terminal Type	2273	1	2	1		0.01	Config	UINT
9.5.2.3	T33 Minimum Value	2272	-20.0	20.0	0.0		0.01	Config	REAL
9.5.2.4	T33 Maximum Value	2271	-20.0	20.0	10.0		0.01	Config	REAL
9.5.2.5	T33 Filter Time	2270	0.0	60.0	0.0	ms	1	Config	REAL
9.5.2.6	T33 Live Zero Threshold Value	2274	-20.0	20.0	-10.0		0.01	Config	REAL
9.5.2.7	T33 Live Zero Timeout Value	2275	0.0	60.0	0.0	s	0.01	Config	REAL

6.6.2 Temperature Measurement

6.6.2.1 Temperature Measurement Status

Index	Name	Number	Min	Max	Default	Unit	Reso	Handling Type	Data type
9.3.2	T4 Temperature Value	4040	-1000.0	1000.0	0.0	°C	1	Process	REAL
9.3.3	T8 Temperature Value	4041	-1000.0	1000.0	0.0	°C	1	Process	REAL
9.3.4	T12 Temperature Value	4042	-1000.0	1000.0	0.0	°C	1	Process	REAL
9.3.5	T16 Temperature Value	4043	-1000.0	1000.0	0.0	°C	1	Process	REAL
9.3.6	T20 Temperature Value	4044	-1000.0	1000.0	0.0	°C	1	Process	REAL

6.6.2.2 Temperature Inputs

6.6.2.2.1 Input T4

Index	Name	Number	Min	Max	Default	Unit	Reso	Handling Type	Data type
9.4.1.1	T4 Terminal Mode	4045	0	7	0		1	Config	UINT
9.4.1.2	T4 Connection Type	4046	0	4	0		1	Config	UINT
9.4.1.3	T4 Temperature Sensor Type	4047	0	19	0		1	Config	UINT
9.4.1.4	T4 Offset	4048	-50.0	50.0	0.0	°C	1	Config	REAL

6.6.2.2.2 Input T8

Index	Name	Number	Min	Max	Default	Unit	Reso	Handling Type	Data type
9.4.2.1	T8 Terminal Mode	4049	0	7	0		1	Config	UINT
9.4.2.2	T8 Connection Type	4050	0	4	0		1	Config	UINT
9.4.2.3	T8 Temperature Sensor Type	4051	0	19	0		1	Config	UINT
9.4.2.4	T8 Offset	4052	-50.0	50.0	0.0	°C	1	Config	REAL

6.6.2.2.3 Input T12

Index	Name	Number	Min	Max	Default	Unit	Reso	Handling Type	Data type
9.4.3.1	T12 Terminal Mode	4053	0	7	0		1	Config	UINT
9.4.3.2	T12 Connection Type	4054	0	4	0		1	Config	UINT
9.4.3.3	T12 Temperature Sensor Type	4055	0	19	0		1	Config	UINT
9.4.3.4	T12 Offset	4056	-50.0	50.0	0.0	°C	1	Config	REAL

6.6.2.2.4 Input T16

Index	Name	Number	Min	Max	Default	Unit	Reso	Handling Type	Data type
9.4.4.1	T16 Terminal Mode	2298	0	7	0		1	Config	UINT
9.4.4.2	T16 Connection Type	4058	0	4	0		1	Config	UINT
9.4.4.3	T16 Temperature Sensor Type	4059	0	19	0		1	Config	UINT
9.4.4.4	T16 Offset	4060	-50.0	50.0	0.0	°C	1	Config	REAL

6.6.2.2.5 Input T20

Index	Name	Number	Min	Max	Default	Unit	Reso	Handling Type	Data type
9.4.5.1	T20 Terminal Mode	4017	0	7	0		1	Config	UINT
9.4.5.2	T20 Connection Type	4062	0	4	0		1	Config	UINT
9.4.5.3	T20 Temperature Sensor Type	4063	0	19	0		1	Config	UINT
9.4.5.4	T20 Offset	4064	-50.0	50.0	0.0	°C	1	Config	REAL

6.6.3 Voltage Measurement

6.6.3.1 Voltage Measurement Status

Index	Name	Number	Min	Max	Default	Unit	Reso	Handling Type	Data type
9.3.1	X52 Voltage	4086	0.0	10000.0	0.0	V	0.1	Process	REAL
9.3.2	X52 Frequency	4087	-400.0	400.0	0.0	Hz	0.01	Process	REAL
9.3.3	X52 Phase Diff.	4088	-180.0	180.0	0.0	°	1	Process	REAL
9.3.4	X52 Voltage L1	4082	-10000.0	10000.0	0.0	V	0.1	Process	REAL
9.3.5	X52 Voltage L3	4083	-10000.0	10000.0	0.0	V	0.1	Process	REAL
9.3.6	X53 Voltage	4089	0.0	10000.0	0.0	V	0.1	Process	REAL
9.3.7	X53 Frequency	4090	-400.0	400.0	0.0	Hz	0.01	Process	REAL
9.3.8	X53 Phase Diff.	4091	-180.0	180.0	0.0	°	1	Process	REAL
9.3.9	X53 Voltage L1	4084	-10000.0	10000.0	0.0	V	0.1	Process	REAL
9.3.10	X53 Voltage L3	4085	-10000.0	10000.0	0.0	V	0.1	Process	REAL

6.6.3.2 Voltage Input X52

Index	Name	Number	Min	Max	Default	Unit	Reso	Handling Type	Data type
9.4.1	X52 Terminal Mode	4099	0	2	0		1	Configuration	UINT
9.4.2	X52 Terminal Voltage Range	4100	1.0	3.4e+38	1.0	V	0.1	Configuration	REAL
9.4.3	X52 Meas. Transformer Grid-Side Voltage	4101	1.0	1e+05	1.0	V	0.1	Configuration	REAL
9.4.4	X52 Meas. Transformer Converter-Side Voltage	4102	1.0	1000.0	1.0	V	0.1	Configuration	REAL
9.4.5	X52 Meas. Transformer Phase Shift	4103	-180.0	180.0	0.0	°	1	Configuration	REAL

6.6.3.3 Voltage Input X53

Index	Name	Number	Min	Max	Default	Unit	Reso	Handling Type	Data type
9.5.1	X53 Terminal Mode	4104	0	2	0		1	Configuration	UINT
9.5.2	X53 Terminal Voltage Range	4105	1.0	3.4e+38	1.0	V	0.1	Configuration	REAL
9.5.3	X53 Meas. Transformer Grid-Side Voltage	4106	1.0	1e+05	1.0	V	0.1	Configuration	REAL
9.5.4	X53 Meas. Transformer Converter-Side Voltage	4107	1.0	1000.0	1.0	V	0.1	Configuration	REAL
9.5.5	X53 Meas. Transformer Phase Shift	4108	-180.0	180.0	0.0	°	1	Configuration	REAL

6.7 Connectivity Integrated Communication

6.7.1 Communication Interfaces

6.7.1.1 Host Settings

Index	Name	Number	Min	Max	Default	Unit	Reso	Handling Type	Data type
10.2.1.1	Fully Qualified Domain Name	7036	-	-	-		1	Configuration	STRING

6.7.1.2 Ethernet Interface X0

6.7.1.2.1 IPv4 Settings

This is a menu screen for enabling IP configuration of the X0 interface. Check the available settings via the control panel or MyDrive® Insight.

6.7.1.2.2 IPv4 Status

This is a menu screen containing information about the IP configuration of the X0 interface. Check the available information via the control panel or MyDrive® Insight.

6.7.1.2.3 Ethernet Interface X1/X2 Settings

6.7.1.2.3.1 IPv4 Settings

This is a menu screen for enabling IP configuration of the X1/X2 interface. Check the available settings via the control panel or MyDrive® Insight.

6.7.1.2.3.2 IPv4 Status

This is a menu screen containing information about the IP configuration of the X1/X2 interface. Check the available information via the control panel or MyDrive® Insight.

6.7.1.2.4 Ethernet port X0

6.7.1.2.4.1 X0 Settings

Index	Name	Number	Min	Max	Default	Unit	Reso	Handling Type	Data type
10.1.1.4.1.1	Link configuration X0	7047	0	4	0		1	Config	USINT

6.7.1.2.5 Ethernet port X1

6.7.1.2.5.1 X1 Settings

Index	Name	Number	Min	Max	Default	Unit	Reso	Handling Type	Data type
10.1.1.5.1.1	Link Configuration X1	7048	0	4	0		1	Config	USINT

6.7.1.2.6 Ethernet port X2

6.7.1.2.6.1 X2 Settings

Index	Name	Number	Min	Max	Default	Unit	Reso	Handling Type	Data type
10.1.1.6.1.1	Link Configuration X2	7049	0	4	0		1	Config	USINT

6.7.1.2.7 Port Mirroring

This is a menu screen for enabling and disabling the port-mirroring function for network troubleshooting with a network analyzer tool. Check the available configurations via the control panel or MyDrive® Insight.

6.7.1.3 Protocols

6.7.1.3.1 PROFINET®

6.7.1.3.1.1 Status

6.7.1.3.1.2 PROFINET® Report

This is the PROFINET® report screen showing active PROFINET® connection and configuration information. Check the available information via the control panel or MyDrive® Insight.

6.7.1.3.1.3 Configuration

Index	Name	Number	Min	Max	Default	Unit	Reso	Handling Type	Data type
10.1.2.1.2.1	Name of Station	7080	-	-	-		1	Config	STRING

6.7.1.3.1.4 Diagnosis

Index	Name	Number	Min	Max	Default	Unit	Reso	Handling Type	Data type
10.1.2.1.3.1	Diagnostic Fault	7081	0	1	1		1	Config	BOOL
10.1.2.1.3.2	Diagnostic Warning	7083	0	1	1		1	Config	BOOL

6.7.1.3.2 Modbus® TCP

6.7.1.3.2.1 Configuration

Index	Name	Number	Min	Max	Default	Unit	Reso	Handling Type	Data type
10.1.2.2.1.1	Persistent Storage	7061	0	1	0		1	Config	BOOL
10.1.2.2.1.2	Byte Order	7062	0	1	0		1	Config	USINT
10.1.2.2.1.3	Word Order	7063	0	1	1		1	Config	USINT

7 Parameter Descriptions

7.1 How to read Parameter Descriptions

The following chapters contain descriptions for all the parameters in the Propulsion and Machinery application software. Each chapter represents a single subgroup within the menu structure.

First the group is described. After that all parameters are listed and description. If applicable, the parameter selections are listed in the table, containing further descriptions for each selection.

The following is an example of a parameter description:

P1.2.3^[1] Parameter Name^[2] No. 1234^[3]

This is a parameter description.^[4]

Number	Name	Description
0 ^[5]	Name of selection 1 ^[6]	Description of selection 1. ^[7]
1	Name of selection 2	Description of selection 2.

1]: The index number of the parameter, that is, the menu location.

[2]: Name of the parameter.

[3]: Unique identification number of the parameter.

[4]: Description of the parameter.

[5]: Selection number.

[6]: Selection name.

[7]: Description of the selection.

7.2 Monitoring (Menu Index 1)

7.2.1 Basic Monitoring (Menu Index 1.1)

P 1.1.1 DC Source Current No. 9000

Shows the DC source current.

P 1.1.2 DC Source Voltage No. 9055

Shows the DC source voltage.

P 1.1.3 DC-link Current No. 5115

Shows the actual DC-link current.

P 1.1.4 DC-link Voltage No. 9044

Shows the actual DC-link voltage.

P 1.1.2 DC Source Voltage No. 9055

Shows the DC source voltage.

P 1.1.3 DC-link Current No. 5115

Shows the actual DC-link current.

P 1.1.4 DC-link Voltage No. 9044

Shows the actual DC-link voltage.

P 1.1.5 Application Status Word 1 No. 6201

Shows the current status of the Application Status Word 1.

Bit No.	Name	Description
0	Ready to Run	0: The converter is not ready to start modulation. Check 'DC/DC Control Ready Status Word' and 'Application Ready Status Word'. 1: The converter is ready to start modulation
1	Run	0: The unit is not running (modulating) 1: The unit is running (modulating)
2	Info active (static)	Static status signal for info events. 0: One or more info level events are active 1: No info level events active.
3	Warning (static)	Static status signal for warning events. 0: No warning level events active. 1: One or more warning level events are active.
4	Fault (static)	Static status signal for fault events. 0: No fault level events active. 1: One or more fault level events are active.
5	PC control	0: PC (MyDrive® Insight) is not the active control place 1: PC (MyDrive® Insight) is the active control place.
6	Panel control	0: Panel control is not the active control place 1: Panel control is the active control place.
7	I/O control	0: I/O control is not the active control place 1: I/O control is the active control place.
8	Fieldbus control	0: I/O control is not the active control place 1: I/O control is the active control place.
9	Reserved	-
10	Reserved	-
11	Run enable	0: The Run Enable Input is not active. Start is prohibited. 1: The Run Enable Input is active allowing the converter to start or maintain running.
12	Start command	0: No start request is active from the active control place. 1: The start request is active from the active control place.
13	Quick stop	0: No quick stop is active from I/O or fieldbus.

Bit No.	Name	Description
		1: The quick stop is activated from I/O or fieldbus.
14	Reserved	-
15	Reserved	-

P 1.1.6 Application Status Word 2
No. 6202

Shows the current status of the Application Status Word 2.

Bit No.	Name	Description
0	Info active (toggled)	Toggled status signal for info events. This signal will toggle down for 1 second, whenever a new info event is activated while another info event was already active.
1	Warning active (toggled)	Toggled status signal for warning events. This signal will toggle down for 1 second, whenever a new warning is activated while another warning was already active.
2	Fault active (toggled)	Toggled status signal for fault events. This signal will toggle down for 1 second, whenever a new fault is activated while another fault was already active.
3	Reserved	-
4	Reserved	-
5	Reserved	-
6	Reserved	-
7	Reserved	-
8	Reserved	-
9	Reserved	-
10	Pre-Charge Ready	Pre-Charge Ready is a status signal indicating that DC-link voltage is higher enough for modulation.
11	Reserved	-
12	Ready to Switch On	<p>Ready to Switch On is a status signal indicating that all the application interlocks needed to start the converter are active.</p> <p>1: Converter is ready to switch on.</p> <p>0: Converter is not ready to switch on. One of the following interlocks are missing:</p> <ul style="list-style-type: none"> - Switch On Enable (from fieldbus). - No Quick stop is active. - No fault is active.
13	Reserved	-
14	Reserved	-
15	Reserved	-

P 1.1.7 Fault Status Word 1 No. 6203

Shows the current status of the Fault Status Word 1.

Bit No.	Name	Description
0	Over current	Rectifier overcurrent, DC-link capacitor overcurrent, output overcurrent or output short circuit has occurred.
1	DC-Link Over voltage	DC-link voltage is above normal operating range.
2	DC-Link Under voltage	DC-link voltage is below normal operating range.
3	Reserved	-
4	Unit under temperature	IGBT, rectifier heatsink, or power unit temperature is below normal operating range.
5	Reserved	-
6	Reserved	-
7	Reserved	-
8	Reserved	-
9	Reserved	-
10	Fieldbus issue	Fieldbus process data timeout, watchdog, loss of fieldbus I/O or connection has occurred.
11	HMI control lost	While in control of the converter, Control Panel or PC tool connection is lost.
12	Reserved	-
13	Thermistor Fault	One or more thermistor protection functions is active.
14	Auxiliary device	One or more aux-bus connected power component temperatures is above normal operating range.
15	External temperature measurement	One or more temperature measurement protection functions is active.

P 1.1.8 Fault Status Word 2 No. 6204

Shows the current status of the Fault Status Word 2. B0: Analog Input Live Zero B3: Quick Stop Active B4: Thermistor Over Temp B6: External Exception B7: Cooling Supervision B8: Fieldbus Watchdog.

Bit No.	Name	Description
0	Analog Input Live Zero	One of the analog inputs live zero fault is active. 0: No live zero fault is active 1: One or more of the analog inputs live zero faults are active
1	Reserved	-
2	Reserved	-
3	Quick Stop Active	0: No quick stop fault is active 1: One or more of the quick stop faults are active
4	Thermistor Over Temperature	0: No thermistor over temperature faults is active 1: One or more of the thermistors over temperature faults are active
5	Reserved	-
6	External Fault	0: None of the External Event faults are active 1: One or more of the External Event faults are active
7	Cooling Supervision Fault	0: No cooling supervision faults is active 1: Cooling supervision fault is active
8	Fieldbus Watchdog	0: Fieldbus watchdog fault is not active. 1: Fieldbus watchdog fault is active.
9	Reserved	-
10	Reserved	-
11	Reserved	-
12	Reserved	-
13	Reserved	-
14	Reserved	-
15	Reserved	-

P 1.1.9 Warning Status Word 1 No. 6205

Shows the current status of the Warning Status Word 1.

Bit No.	Name	Description
0	Over current	Rectifier overcurrent, DC-link capacitor overcurrent, output overcurrent or output short circuit has occurred.
1	DC-Link Over voltage	DC-link voltage is above normal operating range.
2	DC-Link Under voltage	DC-link voltage is below normal operating range.
3	Reserved	-
4	Unit under temperature	IGBT, rectifier heatsink, or power unit temperature is below normal operating range.
5	Reserved	-
6	Reserved	-

Bit No.	Name	Description
7	Reserved	-
8	Reserved	-
9	Reserved	-
10	Fieldbus issue	Fieldbus process data timeout, watchdog, loss of fieldbus I/O or connection has occurred.
11	HMI control lost	While in control of the converter, Control Panel or PC tool connection is lost.
12	Reserved	-
13	Thermistor Warning	One or more thermistor protection functions is active.
14	Auxiliary device	One or more aux-bus connected power component temperatures is above normal operating range.
15	External temperature measurement	One or more temperature measurement protection functions is active.

P 1.1.10 Warning Status Word 2

Description: Shows the current status of the Warning Status Word 2. B0: Analog Input Live Zero B3: Quick Stop Active B4: Thermistor Over Temp B6: External Exception B7: Cooling Supervision B8: Fieldbus Watchdog.

Bit No.	Name	Description
0	Analog Input Live Zero	One of the analog inputs live zero warning is active. 0: No live zero warning is active 1: One or more of the analog inputs live zero faults are active
1	Reserved	-
2	Reserved	-
3	Quick Stop Active	0: No quick stop warning is active 1: One or more of the quick stop warnings are active
4	Thermistor Over Temperature	0: No thermistor over temperature Warning is active 1: One or more of the thermistors over temperature warnings are active
5	Reserved	-
6	External Warning	0: None of the External Event warnings are active 1: One or more of the External Event warnings are active
7	Cooling Supervision Warning	0: No cooling supervision warning is active 1: Cooling supervision warning is active
8	Fieldbus Watchdog	0: Fieldbus watchdog warning is not active. 1: Fieldbus watchdog warnings is active.
9	Reserved	-
10	Reserved	-
11	Reserved	-
12	Reserved	-
13	Reserved	-
14	Reserved	-
15	Reserved	-

P 1.1.11 Last Fault Number No. 1610

Shows the number of the most recent active fault.

P 1.1.12 Last Warning Number No. 1609

Shows the number of the most recent active warning.

P 1.1.13 DC/DC Control Status Word No. 6545

Shows the current status of the DC/DC Control Status Word.

Bit No.	Name	Description
0	Converter Control Ready	0: DC/DC Converter control is not ready. See DC/DC Control Ready Status Word (No. 5096) 1: DC/DC Converter control is ready to modulate.
1	Running	0: DC/DC Converter is not running. 1: DC/DC Converter is running.
2	Reserved	-
3	Fault Active	0: No fault is active 1: One or more of the quick stop warnings are active
4	Reserved	-
5	Reserved	-
6	DC-link Charged	0: DC-link is not charged. 1: DC-link is charged.
7	Reserved	-
8	Reserved	-
9	Reserved	-
10	Reserved	-
11	Reserved	-
12	Reserved	-
13	Reserved	-
14	Reserved	-
15	Reserved	-

P 1.1.14 DC/DC Control Ready Status Word
No. 6520

Shows the current status of the DC/DC Control Ready Status Word.

Bit No.	Name	Description
0	Run Enabled	0: Run Enable is missing 1: Run Enable is active
1	Fault Active	0: One or multiple faults are active 1: No fault is active
2	Pre-Charge Done	0: DC-link pre-charging is not completed 1: DC-link pre-charging is completed
3	Reserved	-
4	Power unit ready	0: Power unit is not ready 1: Power unit is ready
5	Reserved	-
6	Reserved	-
7	Reserved	-
8	Reserved	-
9	Valid LCL filter values	0: LCL filter data is not correct 1: LCL filter data is correct
10	Reserved	-
11	Reserved	-
12	Reserved	-
13	Reserved	-
14	Reserved	-
15	Reserved	-

P 1.1.15 Application Ready Status Word
No. 6525

Description: Shows the status of the Application Ready Status Word. B0: Switch On Enabled B3: Quick Stop Inverse.

Bit No.	Name	Description
0	Switch On Enabled	1: Switch on enable from fieldbus is active. 0: Switch on enable from fieldbus is missing.
1	Reserved	-
2	Reserved	-
3	Quick Stop Inverse	1: Quick Stop not active 0: Quick Stop active
4	Reserved	-
5	Reserved	-
6	Reserved	-
7	Reserved	-
8	Reserved	-

Bit No.	Name	Description
9	Reserved	-
10	Reserved	-
11	Reserved	-
12	Reserved	-
13	Reserved	-
14	Reserved	-
15	Reserved	-

P 1.1.16 Limit Control Status Word No. 9080

Shows the currents status of the DC/DC Limit Control Status Word.

Bit No.	Name	Description
0	Pos. DC Source Current Limit Active	0: Positive DC Source Current Limiter not active (not limiting) 1: Positive DC Source Current Limiter active (limiting)
1	Neg. DC Source Current Limit	0: Negative DC Source Current Limiter not active (not limiting) 1: Negative DC Source Current Limiter active (limiting)
2	Max. DC Source Voltage Limit	0: Maximum DC Source Voltage Limiter not active (not limiting) 1: Maximum DC Source Voltage Limiter active (limiting)
3	Min. DC Source Voltage Limit	0: Minimum DC Source Voltage Limiter not active (not limiting) 1: Minimum DC Source Voltage Limiter active (limiting)
4	DC-link Overvoltage control	0: DC-link overvoltage controller is not active (not regulating) 1: DC-link overvoltage controller is active (regulation)
5	DC-link Undervoltage control	0: DC-link undervoltage controller is not active (not regulating) 1: DC-link undervoltage controller is active (regulation)
6	Pos. DC Source Power Limit	0: Positive DC Source Power Limiter is not active (not limiting) 1: Positive DC Source Power Limiter is active (limiting)
7	Neg. DC Source Power Limit	0: Negative DC Source Power Limiter is not active (not limiting) 1: Negative DC Source Power Limiter is active (limiting)
8	Reserved	-
9	Reserved	-
10	Reserved	-
11	Reserved	-
12	Reserved	-
13	Reserved	-
14	Reserved	-
15	Reserved	-

P 1.1.17 DC-link Nominal Current No. 5120

Shows the DC-link nominal current. The readout is calculated based on other nominal parameters:

$$DC - link\ Nominal\ Current = \frac{DC\ Source\ Nominal\ Voltage * DC\ Source\ Nominal\ Current}{DC - link\ Nominal\ Voltage}$$

P 1.1.18 DC Source Nominal Power No. 5121

Shows the grid nominal power. The readout is calculated based on nominal parameters.

$$DC\ Source\ Nominal\ Power = DC\ Source\ Nominal\ Voltage * DC\ Source\ Nominal\ Current$$

7.2.2 Control Mode and Reference Monitoring (Menu Index 1.2)

P 1.2.1 Active Operation Mode No. 169

Shows the active converter operation mode.

The following are the selections for the parameter.

Number	Operation Mode
0	DC Source Current/Power Control
1	DC-link Current Control
2	DC Source Voltage Control
3	DC-link Voltage Control

P 1.2.2 DC/DC Operation Mode Selection Status Word No. 9079

Shows the current status of the DC/DC Operation Mode Selection Status Word. B0: DC Source Current/Power Control B1: DC-link Current Control B2: DC Source Voltage Control B3: DC-link Voltage Control.

Bit No.	Name	Description
0	DC Source Current/Power Control	1: DC Source Current/Power Control Mode is active 0: DC Source Current/Power Control Mode is not active
1	DC-link Current Control	1: DC-link Current Control Mode is active 0: DC-link Current Control Mode is not active
2	DC Source Voltage Control	1: DC Source Voltage Control Mode is active 0: DC Source Voltage Control Mode is not active
3	DC-link Voltage Control	1: DC-link Voltage Control Mode is active 0: DC-link Voltage Control Mode is not active
4	Reserved	-
5	Reserved	-
6	Reserved	-
7	Reserved	-
8	Reserved	-
9	Reserved	-
10	Reserved	-
11	Reserved	-
12	Reserved	-
13	Reserved	-

Bit No.	Name	Description
14	Reserved	-
15	Reserved	-

P 1.2.3 DC Source Voltage Ref. No. 2833

Shows the DC Source Voltage Reference in % of the DC source nominal voltage.

P 1.2.4 DC Source Current Ref. No. 2884

Shows the DC source current reference in % of the DC source nominal current.

P 1.2.5 DC Source Power Ref. (Actl.) No. 273

Shows the DC source power reference in % of the DC source nominal power.

P 1.2.6 DC-link Current Ref. Actual No. 6141

Actual value of the DC-link current reference in % of the DC-link nominal current.

P 1.2.7 DC-link Voltage Ref. Actual No. 6543

Shows the actual DC-link voltage reference in % of the DC-link nominal voltage.

7.2.3 Limit Monitoring (Menu Index 1.3)

P 1.3.1 Limit Control Status Word No. 9080

Shows the currents status of the DC/DC Limit Control Status Word.

P 1.3.2 Actual DC Source Current Limit No. 2700

Shows the actual absolute value of the DC source current limit in % of the DC Source nominal current.

P 1.3.3 DC Source Power Limit Neg. No. 2909

Shows the DC Source power limit in negative direction in % of the source nominal power.

P 1.3.4 DC Source Power Limit Pos. No. 2913

Shows the DC Source power limit in positive direction in % of the source nominal power.

P 1.3.5 Overvoltage Control Limit No. 6544

Shows the DC-link overvoltage controller Limit.

P 1.3.6 Undervoltage Control Limit No. 6546

Shows the DC-link undervoltage controller limit.

P 1.3.7 Actual Neg. DC Source Current Limit No. 3009

Shows the actual value (after internal limitations) of the DC source current limit in negative direction in % of the DC source nominal current. This limit also takes into account the DC source current magnitude limit.

P 1.3.8 Actual Pos. DC Source Current Limit No. 3008

Description: Shows the actual value (after internal limitations) of the DC source current limit in positive direction in % of the DC source nominal current. This limit also takes into account the DC source current magnitude limit.

7.2.4 Control Place Monitoring

P 1.5.1 Active Control Place No. 113

Shows the active control place that controls the converter.

The following are the selections for the parameter.

Number	Active Control Place
0	PC Control (My Drive Insight)
1	Control Panel
2	Fieldbus Control
3	I/O Control

P 1.5.2 FB Forcing Requested No. 116

Shows the status of the fieldbus control place forcing request active.

P 1.5.3 I/O Forcing Requested No. 117

Shows the status of the I/O-control place forcing request active.

P 1.5.4 Local Control Forcing Requested No. 124

Shows the status of the local control place forcing request (made from control panel REM/LOC button).

7.2.5 DC Source Monitoring (Menu Index 1.6)

P 1.6.1 DC Source Voltage No. 9055

Shows the DC source voltage.

P 1.6.2 DC Source Current No. 9000

Shows the DC source current.

P 1.6.3 DC Source Power No. 9043

Shows the DC source power.

P 1.6.4 DC Source Power % No. 275

Shows the DC source power in % of the DC source nominal power.

P 1.6.5 DC Source Current %No. 9001

Shows the DC source current in % of DC source nominal current.

7.2.6 DC-Link Monitoring (Menu Index 1.7)

P 1.7.1 DC-link Voltage No. 9044

Shows the actual DC-link voltage.

P 1.7.2 DC-link Voltage % No. 6542

Shows the actual DC-link voltage in % of the DC-link nominal voltage.

P 1.7.3 DC-link Current No. 5115

Shows the actual DC-link current. The DC-link current is calculated from DC-link Power.

$$DC - link Current = \frac{DC - link Power}{DC - link Voltage}$$

P 1.7.4 DC-link Current % No. 5116

Shows the actual DC-link current in % of the DC-link nominal current.

7.2.7 Converter Control Monitoring (Menu Index 1.8)

P 1.8.1 Actual Switching Frequency No. 2923

Shows the actual switching frequency.

P 1.8.2 Modulation Index No. 5101

Shows the modulation index.

P 1.8.3 Control Unit Temperature No. 2952

Shows the temperature of the control unit.

7.2.8 Protection Monitoring (Menu Index 1.9)

7.2.8.1 Measured Temp. Protection Status (Menu Index 1.9.1)

P 1.9.1.1 Protection 1 Temp. No. 5200

Shows the temperature measured by the Temperature Measurement board channel configured for Temp. 1 Input (No. 5206) protection.

P 1.9.1.2 Protection 2 Temp. No. 5201

Shows the temperature measured by the Temperature Measurement board channel configured for Temp. 2 Input (No. 5210) protection.

P 1.9.1.3 Protection 3 Temp. No. 5202

Shows the temperature measured by the Temperature Measurement board channel configured for Temp. 3 Input (No. 5214) protection.

P 1.9.1.4 Protection 4 Temp. No. 5203

Shows the temperature measured by the Temperature Measurement board channel configured for Temp. 4 Input (No. 5218) protection.

P 1.9.1.5 Protection 5 Temp. No. 5204

Shows the temperature measured by the Temperature Measurement board channel configured for Temp. 5 Input (No. 5222) protection.

P 1.9.1.6 Protection 6 Temp. No. 5205

Shows the temperature measured by the Temperature Measurement board channel configured for Temp. 6 Input (No. 5226) protection.

P 1.9.1.7 Protection 7 Temp. No. 5273

Shows the temperature measured by the Temperature Measurement board channel configured for Temp. 7 Input (No. 5239) protection.

P 1.9.1.8 Protection 8 Temp. No. 5274

Shows the temperature measured by the Temperature Measurement board channel configured for Temp. 8 Input (No. 5240) protection.

P 1.9.1.9 Protection 9 Temp. No. 5275

Shows the temperature measured by the Temperature Measurement board channel configured for Temp. 9 Input (No. 5241) protection.

P 1.9.1.10 Protection 10 Temp. No. 5276

Shows the temperature measured by the Temperature Measurement board channel configured for Temp. 9 Input (No. 5242) protection.

7.2.8.2 Supervision Monitoring (Menu Index 1.9.2)

P 1.9.2.1 DC Source Superv. Status Word

No. 2968

Description: Shows the current status of the DC Source Supervision Status Word.

B0: DC Source Voltage High

B1: DC Source Voltage Low

B2: DC Source Current High Pos. Dir.

B3: DC Source Current High Neg. Dir.

B4: DcSourceVoltageHigh Warning

B5: DcSourceVoltageLow Warning

B6: DcSourceCurrentHighPosDirection Warning

B7: DcSourceCurrentHighNegDirection Warning

B8: DcSourceVoltageHigh Fault

B9: DcSourceVoltageLow Fault.

Bit No.	Name	Description
0	DC Source Voltage High	1: DC source voltage is above Max. DC source voltage limit (No. 2961)
1	DC Source Voltage Low	1: DC source voltage below min. DC source voltage limit (No. 2960)
2	DC Source Current High Pos. Dir.	1: DC source current above current limit or positive current limit
3	DC Source Current High Neg. Dir.	1: DC source current below current limit (negated) or negative current limit
4	DC Source Voltage High Warning	1: DC source voltage high warning (warning no. 5150) active
5	DC Source Voltage Low Warning	1: DcSourceVoltageLow warning (warning no. 5151) active
6	DC Source Current High Pos. Direction Warning	1: DcSourceCurrentHighPosDirection warning (warning no. 5152) active
7	DC Source Current High Neg. Direction Warning	1: DcSourceCurrentHighNegDirection warning (warning no. 5153) active
8	DC Source Voltage High Fault	1: DcSourceVoltageHigh fault (fault no. 5150) active
9	DC Source Voltage Low Fault	1: DcSourceVoltageLow fault (fault no. 5151) active
10	Reserved	-
11	Reserved	-
12	Reserved	-
13	Reserved	-
14	Reserved	-
15	Reserved	-

7.2.9 Custom Status Word Monitoring (Menu Index 1.10)

P 1.10.1 Custom Status Word

No. 2410

Shows the current status of the Custom Status Word.

7.2.10 Power Unit Monitoring (Menu Index 1.11)

P 1.11.1 Power Capacity

No. 2836

Shows the power capacity of the drive as percentage. The value is derived from the amount of active power units compared to nominal power unit count of the converter.

P 1.11.2 Unit Nominal Voltage **No. 2830**

Shows the nominal voltage setting as a result of the setting of parameter Unit Voltage Class (No. 2832).

P 1.11.3 Unit Nominal Current **No. 2831**

Shows the nominal current of the unit.

P 1.11.4 Heat Sink Temperature **No. 2950**

Shows the temperature of the power unit heat sink.

7.2.11 Cooling Fan Monitoring (Menu Index 1.12)

P 1.12.1 Main Fan Speed **No. 2931**

Shows the speed of the main cooling fan (applicable only for air cooled converters).

P 1.12.2 Internal Fan Speed **No. 2926**

Shows the speed of the internal cooling fan (applicable only for air cooled converters).

7.2.12 Fieldbus Process Data Status

P 1.13.1 Fieldbus Control Word **No. 1335**

Shows the Fieldbus Control Word.

Bit	Name	Description	Further Information
0	Switch On Enable	0: Running is prevented or interrupted 1: Running is not prevented or interrupted	
1	--	Reserved	
2	Quick Stop	0: Activate Quick Stop. 1: Do not activate Quick Stop.	
3	Start	0: Stop modulation if the unit is running 1: Start modulation or keep the unit running	Depending on parameter 5114, a rising edge is or is not required for the unit to start modulation.
4	--	Reserved	
5	--	Reserved	
6	--	Reserved	
7	Warning/Fault Reset	0: No action. 1: Reset active warnings/faults.	This bit is used to acknowledge faults in the converter. A rising edge (a transition from false to true) on this bit issues an event reset request.
8	--	Reserved	
9	--	Reserved	
10	Data Valid	0: Ignore the current incoming process data values, instead use the last processed value when the Data Valid bit was true. 1: Use the current incoming process data values.	For Modbus protocol, Data Valid bit functionality is currently present in the pre-configured control word only. If the control word is mapped to another register with Modbus Customizer, this bit is not considered, and the message is accepted regardless.
11	Watchdog	Incoming fieldbus watchdog bit	This is the input bit used for the fieldbus watchdog.

Bit	Name	Description	Further Information
12	Vendor Specific Bit 1	0: Deactivate the vendor specific function using digital input/output virtual slot 6412 1: Activate the vendor specific function using digital in- put/output virtual slot 6412	
13	Vendor Specific Bit 2	0: Deactivate the vendor specific function using digital input/output virtual slot 6413 1: Activate the vendor specific function using digital in- put/output virtual slot 6413	
14	Vendor Specific Bit 3	0: Deactivate the vendor specific function using digital in- put/output virtual slot 6414 1: Activate the vendor specific function using digital in- put/output virtual slot 6414	
15	Vendor Specific Bit 4	0: Deactivate the vendor specific function using digital in- put/output virtual slot 6415 1: Activate the vendor specific function using digital in- put/output virtual slot 6415	

P 1.13.2 Fieldbus Status Word
No. 1307

Shows the current status of the Fieldbus Status Word.

Bit	Name	Description	Further information
0	Ready to Switch On	0: Not ready to switch on 1: Ready to switch on	This bit is true if all following conditions are satisfied: <ul style="list-style-type: none"> • Switch on enable is present. • Quick stop is not requested. • No faults are active
1	Ready to Run	0: Converter is not ready to start modulation (Check the <i>DC/DC Control Ready Status & Application Ready Status Word</i>) 1: Converter is ready to start modulating	All the bits of DC/DC Control Ready Status as well as the Application Ready Status needs to be high to get the Ready to Run true.
2	Running	0: Converter is not modulating 1: Converter is modulating	
3	Fault	0: No faults are active 1: One or more faults are active	
4	--	Reserved	
5	Quick Stop	0: Quick stop active 1: Quick stop not active	
6	--	Reserved	
7	Warning	0: No warnings active 1: One or more warnings are active	
8	--	Reserved	

Bit	Name	Description	Further information
9	Control by PLC	0: The active control place is not fieldbus 1: The active control place is fieldbus	
10	--	Reserved	
11	Run Enabled	0: Run enable from the dedicated input signal is missing 1: Run enable from the dedicated input signal is present	
12	--	Reserved	
13	--	Reserved	
14	--	Reserved	
15	Watchdog	Outgoing fieldbus watchdog bit	

P 1.13.3 DC/DC Control Word No. 9076

Shows the current status of the DC/DC Control Word.

Bit	Name	Description
0	DC-Link Voltage Control Forcing	0: No action 1: Forces the operating mode to DC-Link Voltage Control
1	DC Source Voltage Control Forcing	0: No action 1: Forces the operating mode to DC Source Voltage Control
2	DC Source Current/Power Control Forcing	0: No action 1: Forces the operating mode to DC Source Current/Power Control
3	DC-link Current Control Forcing	0: No action 1: Forces DC-link Current Control
4	Zero Pos. Current Limit Forcing	0: No action 1: Forces the Positive Current Limit to zero
5	Zero Neg. Current Limit Forcing	0: No action 1: Forced the Negative Current Limit to zero
6–31	--	Reserved

P 1.13.4 FB DC-link Voltage Ref. No. 6533

Shows the incoming fieldbus process data DC-link voltage reference in % of the DC-link Nominal voltage (No. 2834).

P 1.13.5 FB DC Source Current Ref. No. 1261

Shows the incoming fieldbus process data DC source current reference in % of the DC Source Nominal Current (No. 2946).

P 1.13.6 FB DC Source Current Limit Pos. No. 1262

Shows the incoming fieldbus process data DC source current limit in positive direction in % of the DC Source Nominal Current (No. 2946).

P 1.13.7 FB DC Source Current Limit Neg. No. 1263

Shows the incoming fieldbus process data DC source current limit in negative direction in % of the DC Source Nominal Current (No. 2946).

P 1.13.8 FB DC Source Voltage Ref. No. 1264

Shows the incoming fieldbus process data DC source voltage reference in % of the DC Source Nominal voltage (No. 2945).

P 1.13.9 FB DC Source Power Limit Neg. No. 1266

Shows the incoming fieldbus process data DC source power limit in negative direction in % of the DC Source Nominal Power (No. 5121).

P 1.13.10 FB DC Source Power Limit Pos. No. 1265

Shows the incoming fieldbus process data DC source power limit in positive direction in % of the DC Source Nominal Power (No. 5121).

P 1.13.11 FB Overvoltage Limit No. 4512

Shows the incoming fieldbus process data DC-link overvoltage limit in % of the DC-link Nominal voltage (No. 2834).

P 1.13.12 FB Undervoltage Limit No. 4510

Shows the incoming fieldbus process data DC-link undervoltage limit in % of the DC-link Nominal voltage (No. 2834).

P 1.13.13 FB Output Current Limit No. 1511

Shows the incoming fieldbus process data current magnitude limit in % of the DC Source nominal current (No. 2946). This limit is applied both to negative and positive current direction.

P 1.13.14 FB DC-link Current Ref. No. 6139

Shows the incoming fieldbus process data DC-link current reference in % of the DC-link Nominal Current (No. 5120).

P 1.13.10 FB DC Source Power Ref. No. 270

Shows the incoming fieldbus process data DC source power reference in % of the DC Source Nominal Power (No. 5121).

7.3 Parameters (Menu Index 2)

7.3.1 Basic Parameters (Menu Index 2.1)

P 2.1.1 DC Source Nominal Voltage No. 2945

Set the DC source nominal voltage. It is automatically updated if Unit Voltage Class (No. 2832) is changed.

P 2.1.2 DC Source Nominal Current No. 2946

Set the DC source nominal current.

P 2.1.3 DC-link Nominal Voltage No. 2834

Set the DC-link nominal voltage. This parameter is re-initialized based on the unit nominal voltage when set to 0 or if Unit Voltage Class (No. 2832) is changed. This parameter must be set based on the system common DC-bus nominal voltage. This parameter affects the scaling of DC-link voltage reference and readouts as well as DC-link over and undervoltage limit controller references.

P 2.1.4 Unit Voltage Class No. 2832

Select the unit voltage class to optimize the performance of the converter. Each power unit is rated for a wide voltage range which the converter can operate in. This parameter is used to specify a narrower band within that range to determine optimized values for the unit's nominal voltage and current. The Grid Nominal Voltage, DC-link nominal voltage, Over and undervoltage controller limits are calculated automatically whenever this parameter is changed. This parameter also affects the DC-link ready state which is defined as the minimum value the DC-link voltage needs to reach before the modulation can start.

The following are the selections for the parameter.

Number	Name	Description
1	Low-voltage range	Unit nominal voltage and current are set according to the lowest end of the unit's voltage range. • For example, for B5-units this range is 380-440 V AC and 425-

Number	Name	Description
		800 V DC. • For example, for 07-units this range is 500-550 V AC and 560-1100 V DC.
2	Mid-voltage range	Unit nominal voltage and current are set according to the middle of the unit's voltage range. • For example, for B5-units this range is 440-480 V AC and 492-800 V DC. • For example, for 07-units this range is 550-600 V AC and 615-1100 V DC.
3	High-voltage range	Unit nominal voltage and current are set according to the highest end of the unit's voltage range. • For example, for B5-units this range is 480-500 V AC and 537-800 V DC. • For example, for 07-units this range is 600-690 V AC and 671-1100 V DC.
4	Wide-voltage range	Unit nominal voltage and current are set according to the unit's whole voltage range. • For example, for B5-units this range is 380-500 V AC and 350-800 V DC. • For example, for 07-units this range is 500-690 V AC and 350-1100 V DC.

P 2.1.5 Overload Mode

No. 2833

Select the overload mode. Overloading mode selects an overtemperature protection profile for the converter, affecting current limits and protection activation times. With a higher overloading mode, the converter will operate in a greater degree of overloading before protections take effect. Specific limits and activation delays depend on the conditions.

The following are the selections for the parameter.

Number	Name	Description
0	Automatic	The converter automatically determines whether to use the Low or High Overload Mode.
1	Low overload (LO)	The converter uses the lower overloading profile. Overtemperature protection is activated with a lesser degree of overload.
2	High overload (HO1)	The converter uses a higher overloading profile. Overtemperature protection is activated with a higher degree of overload.
3	High overload increased duty (HO2)	The converter uses the highest overloading profile. Overtemperature protection is activated with the highest degree of overload.

P 2.1.6 Current/Power Positive Direction

No. 2947

Select the sign convention to be used for current and power.

The following are the selections for the parameter.

Number	Name	Description
0	From DC-link to DC Source	Current and power are positive when flowing from DC-link side to DC Source side

Number	Name	Description
1	From DC Source to DC-link	Current and power are positive when flowing from DC Source side to DC-link side

7.3.2 Control Mode and References (Menu Index 2.2)

7.3.2.1 Control Mode (Menu Index 2.2.1)

P 2.2.1.1 Operation Mode

Select the converter operation mode.

The following are the selections for the parameter.

Number	Operation Mode
0	DC Source Current/Power Control
1	DC-link Current Control
2	DC Source Voltage Control
3	DC-link Voltage Control
0	DC Source Current/Power Control
1	DC-link Current Control
2	DC Source Voltage Control

P 2.2.1.2 Converter Reference Mode

Select between current and power control in DC Source Current/Power Control operation mode. Power Control reference mode must not be selected in combination with DC-link Current Control operation mode, as it is not supported yet.

The following are the selections for the parameter.

Number	Reference Mode
0	Current Control
1	Power Control

7.3.2.2 DC Source Voltage Reference (Menu Index 2.2.2)

DC Source voltage reference is used to control the load/DC Source side voltage. The following is the reference chain diagram of DC Source Voltage reference.

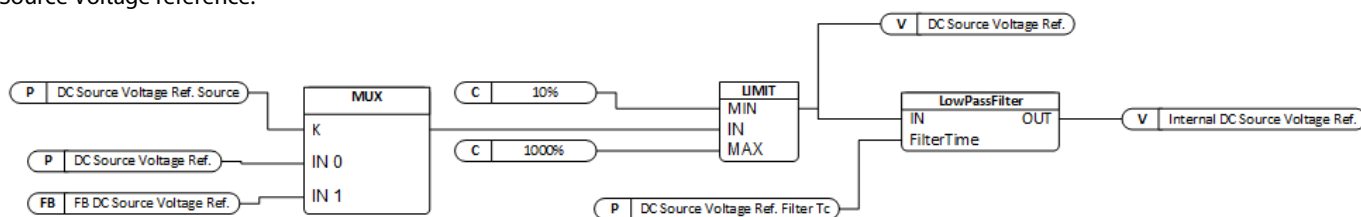

Illustration 13: DC Source Voltage Reference

P 2.2.2.1 DC Source Voltage Ref. Source

No. 5088

Select the source for the DC source voltage reference.

The following are the selections for the parameter.

P 2.2.2.2 DC Source Voltage Ref.

No. 5089

Description: Set the source voltage reference in % of the nominal DC source voltage.

P 2.2.2.3 DC Source Voltage Drooping Gain

No. 5090

Source voltage drooping gain, which represents the change of source voltage reference per current change.

P 2.2.2.4 DC Source Voltage Ref. Filter Tc **No. 6522**

Set the source voltage reference low pass filter time constant.

P 2.2.2.5 DC Source Voltage Drooping Tc **No. 6523**

Filtering time constant of source current when source voltage drooping is used.

7.3.3 DC Source Current Reference (Menu Index 2.2.3)

DC Source current reference is used to control the load/DC Source current. The following is the reference chain diagram of DC Source Current reference.

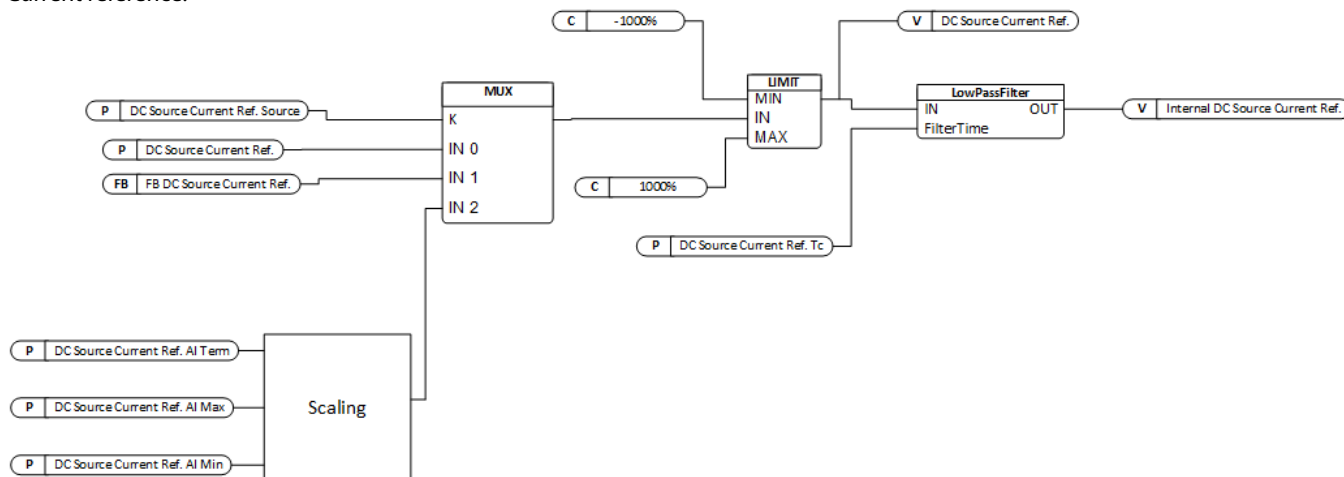

Illustration 14: DC Source Current Reference

P 2.2.3.1 DC Source Current Ref. Source **No. 240**

Select the source for the DC source current reference.

The following are the selections for the parameter.

Number	Reference Source
0	Parameter
1	Fieldbus Reference
2	Analog Input

P 2.2.3.2 DC Source Current Ref. **No. 241**

Set the DC source current reference in % of the DC source nominal current.

P 2.2.3.3 DC Source Current Ref. Tc **No. 242**

Set the filter time for the low-pass filter applied to the DC source current reference.

P 2.2.3.4 DC Source Current Ref. AI Term. No. 243

Select the analog input (terminal or fixed percentage value) for the DC source current reference.

P 2.2.3.5 DC Source Current Ref. AI Max. No. 244

Set the maximum value for scaling the DC source current reference analog input signal.

P 2.2.3.6 DC Source Current Ref. AI Min. No. 246

Set the minimum value for scaling the DC source current reference analog input signal.

7.3.4 DC Source Power Reference (Menu Index 2.2.4)

DC Source power reference is used to control the load/DC Source power. The following is the reference chain diagram of DC Source Power reference.

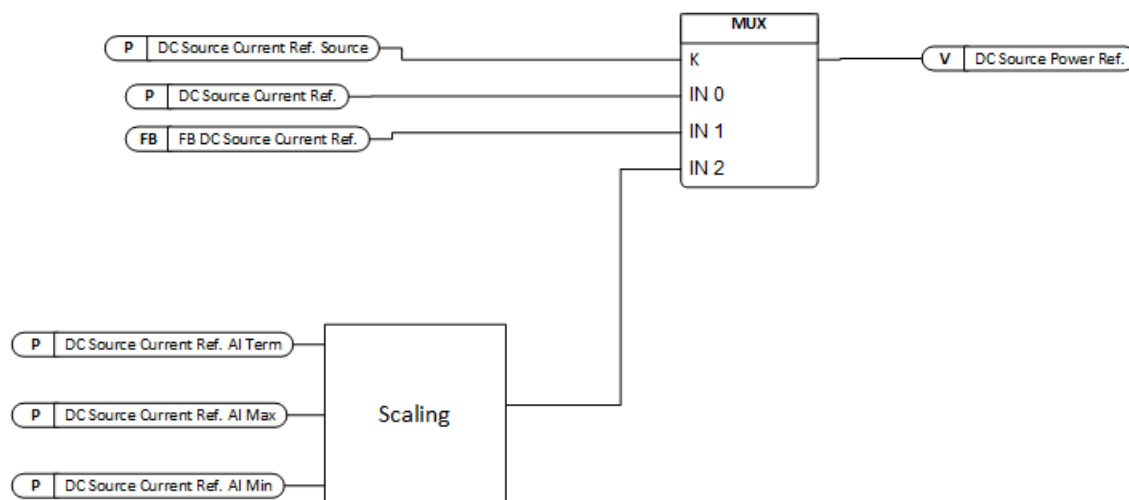

Illustration 15: DC Source Power Reference

P 2.2.4.1 DC Source Power Ref. Source No. 271

Select the source for the DC source power reference.

The following are the selections for the parameter.

Number	Reference Source
0	Parameter
1	Fieldbus Reference
2	Analog Input

P 2.2.4.2 DC Source Power Ref. No. 272

Set the DC source power reference in % of the DC source nominal power.

P 2.2.4.3 DC Source Power Ref. AI Term. No. 274

Select the analog input (terminal or fixed percentage value) for the DC source power reference.

P 2.2.4.4 DC Source Power Ref. AI Max. No. 276

Set the maximum value for scaling the DC source power reference analog input signal.

P 2.2.4.5 DC Source Power Ref. AI Min. No. 277

Set the minimum value for scaling the DC source power reference analog input signal.

7.3.5 DC-link Voltage Reference (Menu Index 2.2.5)

DC-link Voltage reference is used to control DC-link voltage. The following is the reference chain diagram of DC-link Voltage reference.

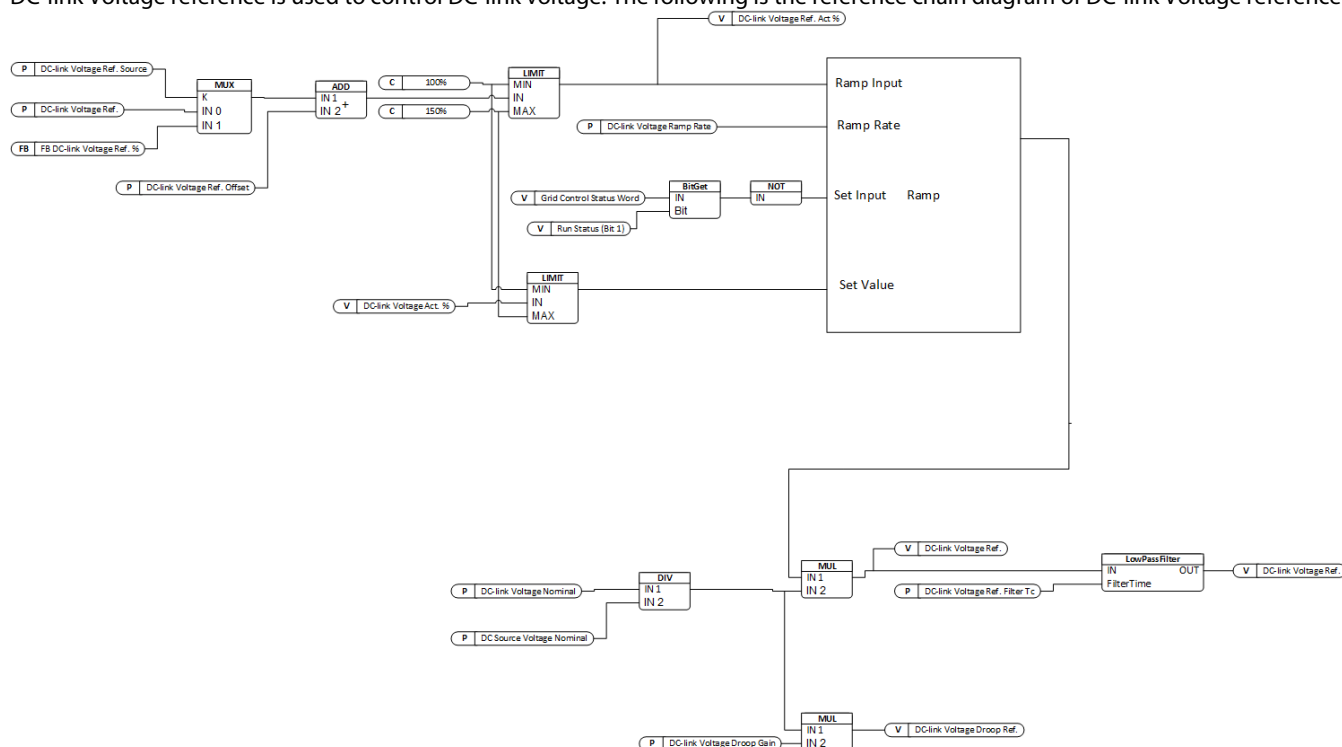

Illustration 16: DC-link Voltage Reference

P 2.2.5.1 DC-link Voltage Ref. Source No. 2916

Select the source for the DC-link voltage reference.

The following are the selections for the parameter.

Number	Reference Source
0	Parameter
1	Fieldbus Reference

P 2.2.5.2 DC-link Voltage Ref. No. 2910

Set the DC-link voltage reference. The percentage is calculated according to par. DC-link Voltage Ref. Mode (No. 2888).

P 2.2.5.3 DC-link Voltage Ref. Offset No. 2914

Set the DC-link voltage reference offset. The percentage is calculated according to par. DC-link Voltage Ref. Mode (No. 2888).

P 2.2.5.4 DC-link Voltage Droop Gain No. 2912

Set the DC-link voltage drooping gain; change of DC voltage reference per (active) current change.

P 2.2.5.5 DC-link Voltage Ramp Rate No. 2893

Set the maximum rate of change for the DC-link voltage reference, DC-link overvoltage, and DC-link undervoltage controller limits.

P 2.2.6.6 DC-link Voltage Ref. Filter Tc No. 2894

Set the DC-link voltage reference low pass filter time constant.

7.3.6 DC-link Current Reference (Menu Index 2.2.6)

P 2.2.6.1 DC-link Current Ref. Source **No. 6138**

Select the DC-link current reference source.

The following are the selections for the parameter.

Number	Reference Source
0	Parameter
1	Fieldbus Reference
2	Analog Input

P 2.2.6.2 DC-link Current Ref. **No. 6136**

Set the DC-link current reference (in % of the DC-link nominal current) when reference source is set to parameter.

P 2.2.6.3 DC-link Current Ref. Filter Tc **No. 6140**

Set the DC-link current reference low-pass filter time constant.

P 2.2.6.4 DC-Link Current Droop Curve U **No. 5302**

Set the voltage values (in % of the nominal DC-link voltage) for the DC-link current droop curve points.

P 2.2.6.5 DC-link Current Droop Curve I **No. 5301**

Set the current reference values (in % of the DC-link nominal current) for the DC-link current droop curve points.

P 2.2.6.6 DC-Link Current Droop Curve G **No. 5300**

Set DC-link current droop curve slopes.

7.3.7 Limits (Menu Index 2.3)

7.3.7.1 DC Source Voltage Limits (Menu Index 2.3.1)

P 2.3.1.1 Min. DC Source Voltage Limit

Set the minimum source voltage in % of DC source nominal voltage. References are automatically limited to keep the DC source voltage above this level.

P 2.3.1.2 Max. DC Source Voltage Limit

Set the maximum source voltage in % of DC source nominal voltage. References are automatically limited to keep the DC source voltage below this level.

7.3.7.2 DC Source Current Limits (Menu Index 2.3.2)

DC Source Current limits group contains overall current limit as well as directional current limits. Directional (positive and negative) current limits are the process current limits and are used to configure, for example, charging and discharging limits when connected to a battery as a load. The block diagram for negative, positive, and total current limit is shown below:

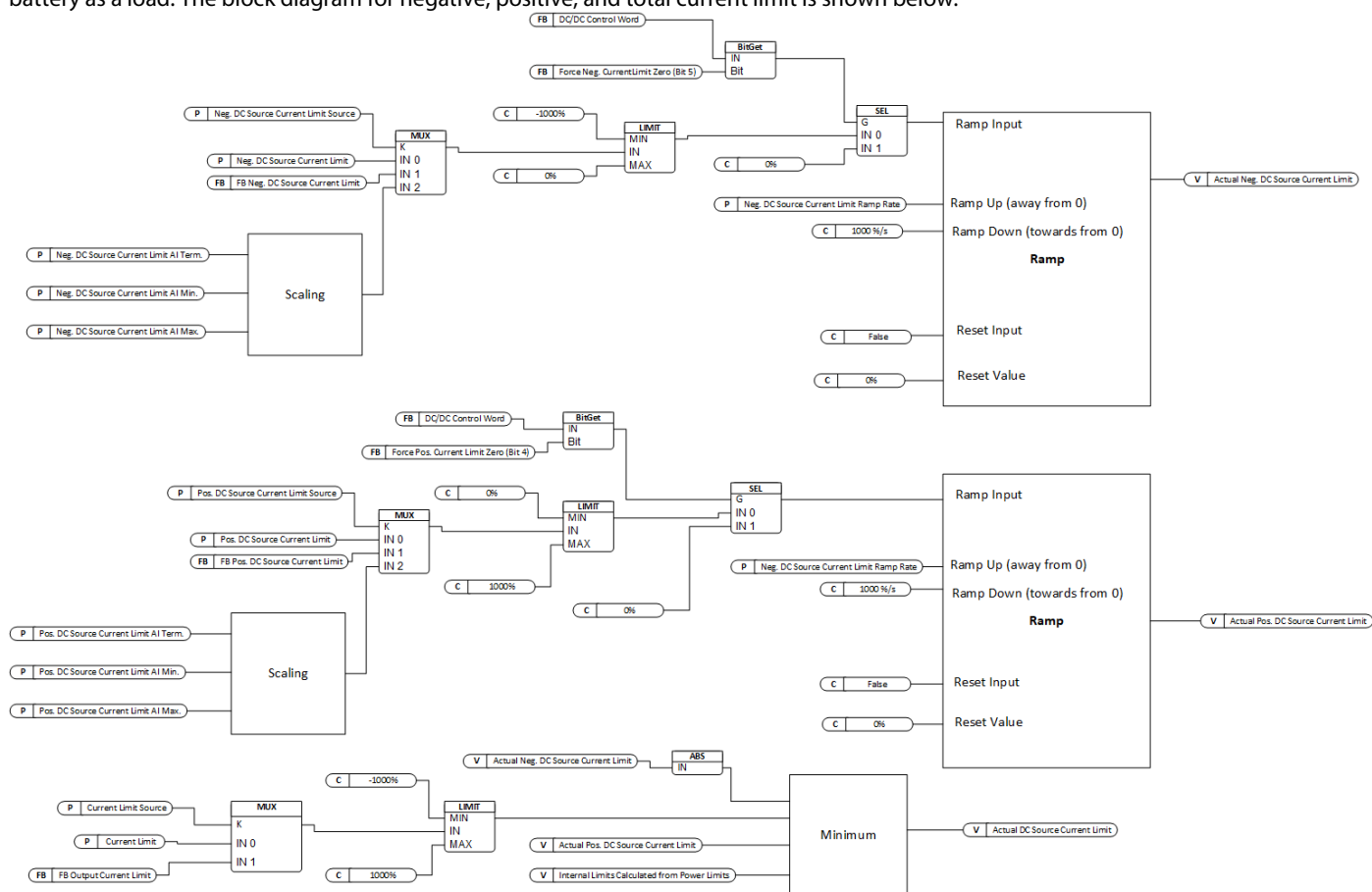

Illustration 17: DC Source Current Limits

P 2.3.2.1 Current Limit Source

No. 2852

Current magnitude limit source selection.

The following are the selections for the parameter.

Number	Reference Source
0	Parameter
1	Fieldbus Reference

P 2.3.2.2 Current Limit

No. 2851

Set the absolute current limit in % of the DC Source nominal current. It is applied both to negative and positive current direction.

P 2.3.2.3 Neg. DC Source Current Limit Source No. 2859

Select the source for the DC source current limit in negative direction.

The following are the selections for the parameter.

Number	Reference Source
0	Parameter
1	Fieldbus Reference
2	Analog Input

P 2.3.2.4 Neg. DC Source Current Limit No. 2860

Set the DC Source current limit in negative direction in % of the source nominal current.

P 2.3.2.5 Neg. DC Source Current Limit AI Term. No. 2974

Select the analog input (terminal or fixed percentage value) for the negative dc source current limit.

P 2.3.2.6 Neg. DC Source Current Limit AI Max. No. 2975

Set the maximum value for scaling the negative DC source current limit analog input signal.

P 2.3.2.7 Neg. DC Source Current Limit AI Min. No. 2976

Set the minimum value for scaling the negative DC source current limit analog input signal.

P 2.3.2.8 Neg. DC Source Current Limit Ramp Rate No. 2886

Set the negative dc source current limit maximum rate of change in percent (of the DC source nominal current) per second. The rate of change is limited only when the absolute value of the current limit is increased.

P 2.3.2.9 Pos. DC Source Current Limit Source No. 2890

Select the source for the DC source current limit in positive direction.

The following are the selections for the parameter.

Number	Reference Source
0	Parameter
1	Fieldbus Reference
2	Analog Input

P 2.3.2.10 Pos. DC Source Current Limit No. 2891

Set the DC Source current limit in positive direction in % of the source nominal current.

P 2.3.2.11 Pos. DC Source Current Limit AI Term. No. 2971

Select the analog input (terminal or fixed percentage value) for the positive dc source current limit.

P 2.3.2.12 Pos. DC Source Current Limit AI Max. No. 2972

Set the maximum value for scaling the positive DC source current limit analog input signal.

P 2.3.2.13 Pos. DC Source Current Limit AI Min. No. 2973

Set the minimum value for scaling the positive DC source current limit analog input signal.

P 2.3.2.14 Pos. DC Source Current Limit Ramp Rate No. 2887

Set the positive dc source current limit maximum rate of change in percent (of the DC source nominal current) per second. The rate of change is limited only when the absolute value of the current limit is increased.

7.3.7.3 DC Source Power Limits (Menu Index 2.3.3)

Directional power limits (positive and negative) can also be used to control the power flow in both directions. For example, in the case of battery energy storage system as load, they can be configured as charging and discharging power limits. The power limits are converted to internal current limits and the minimum of Actual DC Source Current Limit, and the internal calculated limits are used by the converter. The block diagram for negative, positive and total current limit is shown below:

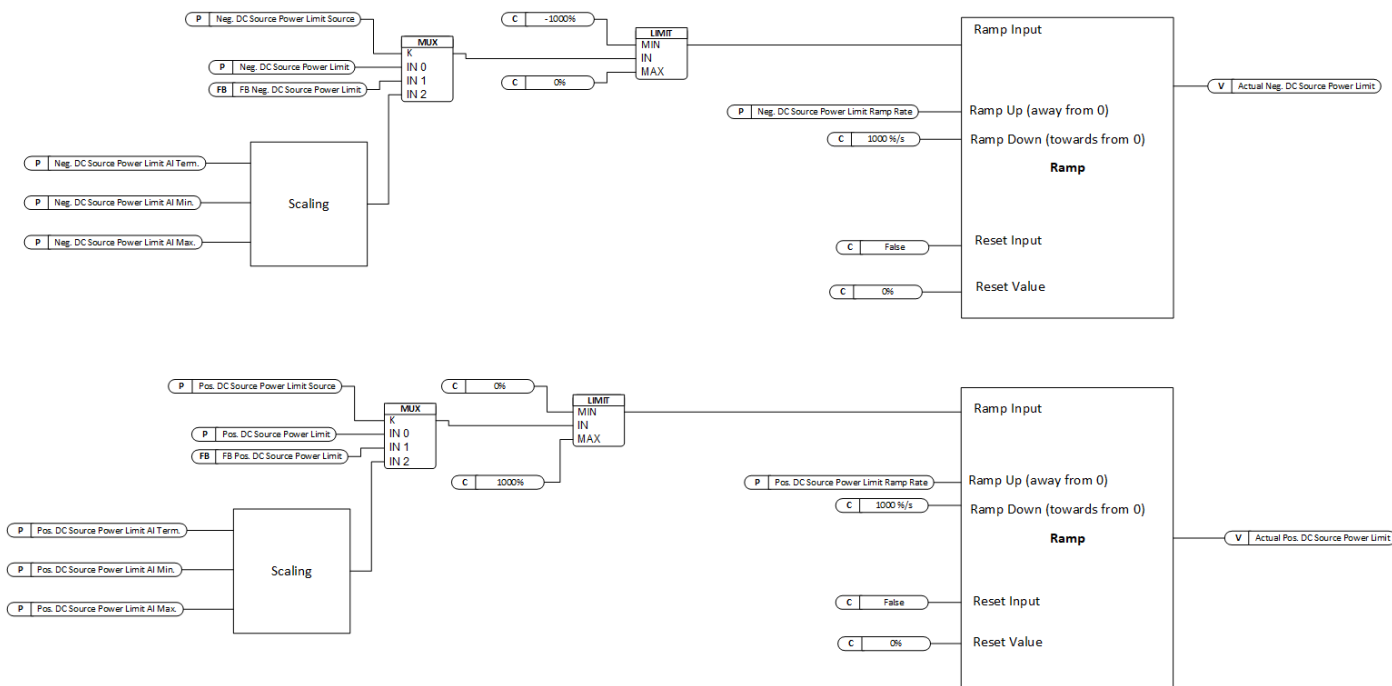

Illustration 18: DC Source Power Limits

P 2.3.3.1 Neg. DC Source Power Limit Source No. 2870

Select the source for the DC source power limit in negative direction.

The following are the selections for the parameter.

Number	Reference Source
0	Parameter
1	Fieldbus Reference
2	Analog Input

P 2.3.3.2 DC Source Power Limit Neg. No. 2872

Set the DC Source power limit in negative direction in % of the source nominal power.

P 2.3.3.3 Neg. DC Source Power Limit AI Term. No. 2980

Select the analog input (terminal or fixed percentage value) for the negative dc source power limit.

P 2.3.3.4 Neg. DC Source Power Limit AI Max. No. 2981

Set the maximum value for scaling the negative DC source power limit analog input signal.

P 2.3.3.5 Neg. DC Source Power Limit AI Min. No. 2982

Set the minimum value for scaling the negative DC source power limit analog input signal.

P 2.3.3.6 Neg. DC Source Power Limit Ramp Rate No. 2899

Set the negative DC source power limit maximum rate of change in percent (of the DC source nominal power) per second. The rate of change is limited only when the absolute value of the power limit is increased.

P 2.3.3.7 Pos. DC Source Power Limit Source No. 2892

Select the source for the DC source power limit in a positive direction.

The following are the selections for the parameter.

Number	Reference Source
0	Parameter
1	Fieldbus Reference

Number	Reference Source
2	Analog Input

P 2.3.3.8 DC Source Power Limit Pos. No. 2896

Set the DC Source power limit in positive direction in % of the source nominal power.

P 2.3.3.9 Pos. DC Source Power Limit AI Term. No. 2977

Select the analog input (terminal or fixed percentage value) for the positive dc source power limit.

P 2.3.3.10 Pos. DC Source Power Limit AI Max. No.2978

Set the maximum value for scaling the positive DC source power limit analog input signal.

P 2.3.3.11 Pos. DC Source Power Limit AI Min. No. 2979

Set the minimum value for scaling the positive DC source power limit analog input signal.

P 2.3.3.12 Pos. DC Source Power Limit Ramp Rate No. 2908

Set the positive DC source power limit maximum rate of change in percent (of the DC source nominal power) per second. The rate of change is limited only when the absolute value of the power limit is increased.

7.3.7.4 DC Link Voltage Limiters (Menu Index 2.3.4)

DC/DC Converter has both DC-link over and under voltage controller limits available as references. Over and under voltage limits have dependency on Unit Voltage Class (No. 2832) and changing the voltage class will change the limits.

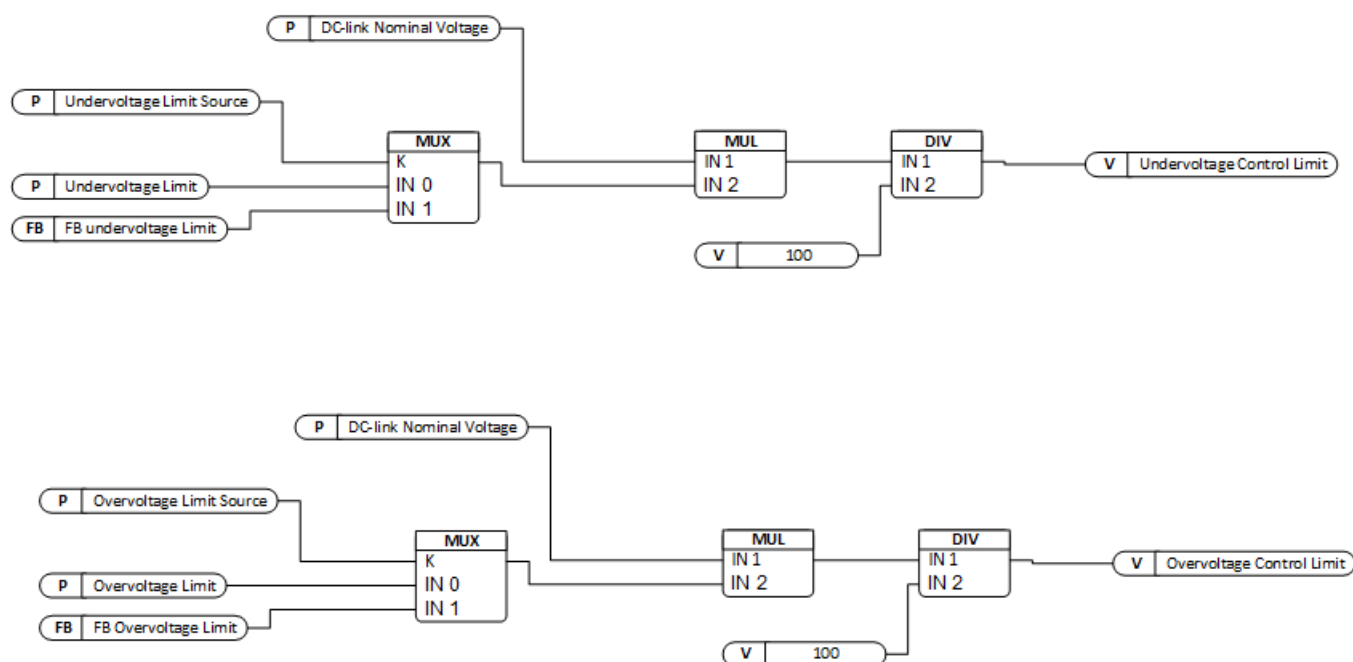
Illustration 19: Over and Undervoltage limit controller

7.3.7.4.1 Undervoltage Limit Controller (Menu Index 2.3.4.1)

P 2.3.4.1.1 Undervoltage Control **No. 1809**

Enables the DC-link undervoltage controller.

The following are the selections for the parameter.

Number	Selection List
0	Disabled
1	Enabled.

P 2.3.4.1.2 Undervoltage Limit Source **No. 2900**

Select the source for the DC-link undervoltage controller limit.

The following are the selections for the parameter.

Number	Reference Source
0	Parameter
1	Fieldbus Reference

P 2.3.4.1.3 Undervoltage Limit **No. 2901**

Set the DC-link undervoltage limit in % of the DC-link nominal voltage.

7.3.7.4.2 Overvoltage Limit Controller (Menu Index 2.3.4.2)

P 2.3.4.2.1 Overvoltage Control **No. 1802**

Enables the DC-link overvoltage controller.

The following are the selections for the parameter.

Number	Selection List
0	Disabled
1	Enabled.

P 2.3.4.2.2 Overvoltage Limit Source **No.2897**

Select the source for the DC-link overvoltage controller limit.

The following are the selections for the parameter.

Number	Reference Source
0	Parameter
1	Fieldbus Reference

P 2.3.4.2.3 Overvoltage Limit **No. 2898**

Set the DC-link overvoltage limit in % of the DC-link nominal voltage.

7.3.7.5 Digital and Analog Input Selection List

For selection of digital and analog inputs, a dynamically generated selection list of available terminals is generated based on the slot number of the IO & Relay option board. For example, a snapshot of possibly available digital options seen through MyDrive Insight with a single IO & Relay option board of slot 202 is shown below:

- IOandRelay [202]: I/O And Relay T13 Digital Input
- IOandRelay [202]: I/O And Relay T14 Digital Input
- IOandRelay [202]: I/O And Relay T15 Digital Input
- IOandRelay [202]: I/O And Relay T16 Digital Input
- IOandRelay [202]: I/O And Relay T17 Digital Input
- IOandRelay [202]: I/O And Relay T18 Digital Input

7.3.8 Digital and Analog Inputs (Menu Index 2.4)

7.3.8.1 Digital Inputs (Menu Index 2.4.1)

P 2.4.1.1 Run Enable Input No. 103

Select an input for enabling the converter to run. Run Enable is a mandatory signal for the converter to run. If removed in the run state then it will stop the converter and the converter will not go into run state without issuing this signal back.

P 2.4.1.2 External Event 1 Input No. 4557

Select an input for activating the external warning/fault 1.

P 2.4.1.3 External Event 2 Input No. 4560

Select an input for activating the external warning/fault 2.

P 2.4.1.4 Cooling Monitor Input No. 2400

Select an input for the cooling monitor signal. Cooling Monitor warning/fault is activated when this input becomes FALSE.

P 2.4.1.5 Force I/O Control Input No. 4513

Select an input for forcing the control place to I/O.

P 2.4.1.6 Force FB Control Input No. 4511

Select an input for forcing the control place to Fieldbus.

P 2.4.1.7 I/O Start Input No. 200

Select an input for starting the unit when the active control place is I/O Control.

P 2.4.1.8 I/O Stop Input No. 201

Select an input for stopping the unit when the active control place is I/O Control. Stop is activated when this input becomes FALSE.

P 2.4.1.9 I/O Reset Input No. 203

Select an input for the warning/fault reset when the active control place is I/O Control. The dependence on control place is selected based on Control Place Independent Reset (No. 109).

P 2.4.1.10 Quick Stop Input No. 212

Select an input for the Quick Stop function. Quick Stop is activated when this input becomes FALSE.

P 2.4.1.11 Quick Stop Input 2 No. 5104

Select an input for the Quick Stop function. Quick Stop is activated when this input becomes FALSE.

7.3.8.2 Analog Inputs (Menu Index 2.4.2)

P 2.4.2.1 DC Source Current Ref. AI Term. No. 243

Select the analog input (terminal or fixed percentage value) for the DC source current reference.

P 2.4.2.2 DC Source Power Ref. AI Term. No. 274

Select the analog input (terminal or fixed percentage value) for the DC source power reference.

P 2.4.2.3 Neg. DC Source Current Limit AI Term. No. 2974

Select the analog input (terminal or fixed percentage value) for the negative dc source current limit.

P 2.4.2.4 Pos. DC Source Current Limit AI Term. No. 2971

Select the analog input (terminal or fixed percentage value) for the positive dc source current limit.

P 2.4.2.5 Neg. DC Source Power Limit AI Term. No. 2980

Select the analog input (terminal or fixed percentage value) for the negative dc source power limit.

P 2.4.2.6 Pos. DC Source Power Limit AI Term. No. 2977

Select the analog input (terminal or fixed percentage value) for the positive dc source power limit.

7.3.9 Digital and Analog Outputs (Menu Index 2.5)

For selection of digital and analog outputs, a dynamically generated selection list of available terminals is generated based on the slot number of the IO & Relay option board. For example, a snapshot of possibly available options seen through MyDrive Insight with a single IO & Relay option board of slot 202 is shown below:

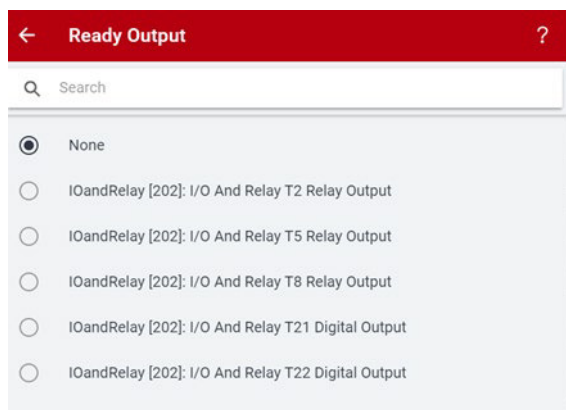

7.3.10 Digital and Analog Outputs (Menu Index 2.5)

7.3.10.1 Digital Outputs (Menu Index 2.5.1)

P 2.5.1.1 Ready Output No. 205

Select an output for the Ready to run signal.

P 2.5.1.2 Run Output No. 206

Select an output for the Run-signal.

P 2.5.1.3 Static Fault Output No. 208

Select an output for the Static Fault Active signal.

P 2.5.1.4 Static Warning Output No. 209

Select an output for the Static Warning Active signal.

P 2.5.1.5 Toggling Fault Output No. 5180

Select an output for the Toggling Fault-signal. This signal goes down for 1 second whenever a new fault is registered while another fault

was already active.

P 2.5.1.6 Toggling Warning Output **No. 5181**

Select an output for the Toggling Warning-signal. This signal goes down for 1 second whenever a new warning is registered while another warning was already active.

P 2.5.1.7 FB CTW Bit 12 Output **No. 5193**

Select an output for the status of the fieldbus control word bit 12.

P 2.5.1.8 FB CTW Bit 13 Output **No. 5194**

Select an output for the status of the fieldbus control word bit 13.

P 2.5.1.9 FB CTW Bit 14 Output **No. 5198**

Select an output for the status of the fieldbus control word bit 14.

P 2.5.1.10 FB CTW Bit 15 Output **No. 5191**

Select an output for the status of the fieldbus control word bit 15.

P 2.5.1.11 DC-link Voltage Superv. Output **No. 5157**

Select an output for the status of the DC-link Voltage Supervision. Signals when the DC-link voltage exceeds Param. DC-link Voltage Superv. Limit (No. 5158).

P 2.5.1.12 DC-link Voltage Superv. Limit **No. 5158**

Set the DC-link Voltage Supervision Limit for monitoring the DC-link Voltage with a digital output.

P 2.5.1.13 Local Control Active Output **No. 5178**

Select an output terminal indicating that the converter is in local control.

P 2.5.1.14 I/O Control Active Output **No. 5177**

Select an output terminal indicating that the converter is in I/O control.

P 2.5.1.15 Fieldbus Control Active Output **No. 5197**

Select an output terminal indicating that the converter is in fieldbus control.

P 2.5.1.16 Active Exception 1 Output **No. 5189**

Select an output for monitoring the warning/fault activation status (output high = exception active).

P 2.5.1.17 Event 1 Number **No. 5188**

Set the number of the event to be assigned for Active Event 1 output.

P 2.5.1.18 Active Event 2 Output **No. 5190**

Select an output for monitoring the warning/fault activation status (output high = event active).

P 2.5.1.19 Event 2 Number **No. 5290**

Set the number of the event to be assigned for Active Event 2 output.

P 2.5.1.20 No Warning Output **No. 217**

Select an output for the No Warning Active signal.

P 2.5.1.21 No Fault Output **No. 218**

Select an output for the No Fault Active signal.

P 2.5.1.22 Local Control Forcing Requested Output **No. 125**

Select an output terminal for the indication that the control place forcing to Local Control is requested with REM/ LOC button of control panel (output high = requested).

P 2.5.1.23 I/O Forcing Requested Output **No. 121**

Select an output terminal for the indication that the control place forcing to I/O Control is requested (output high = requested).

P 2.5.1.24 FB Forcing Requested Output **No. 120**

Select an output terminal for the indication that the control place forcing Fieldbus Control is requested (output high = requested).

P 2.5.1.25 DC Source Voltage Monitoring Output **No. 5160**

Select an output for monitoring the DC source voltage level. Indicates whether the DC Source voltage exceeds par. DC Source Voltage

Monitoring Level (No. 5159).

P 2.5.1.26 DC Source Voltage Monitoring Level No. 5159

Set the level used for monitoring the DC source voltage through the digital output set with par. DC Source Voltage Monitoring Output (No. 5160).

P 2.5.1.26 Source Charging Output No. 5595

Select an output for the source discharging indication.

P 2.5.1.26 Source Discharging Output No. 5543

Select an output for the source discharging indication.

7.3.10.2 Delayed Digital Outputs (Menu Index 2.5.2)

P 2.5.2.1 Delayed Output 1 Content Sel. No. 8032

Select the function for the delayed digital output 1.

The following are the selections for the parameter.

Selection Number	Name	Description
0	Not used	-
1	Ready to Run Status	Ready to run status signal. True = Converter is ready to run, False = Converter is not ready to run.
2	Running Status	Converter's running status signal. True = Converter is running, False = Converter is not running.
3	Warning Active (Static)	Static warning active status signal. True = One or more warnings are active, False = No warnings are active.
4	Fault Active (Static)	Static fault active status signal. True = One or more faults are active, False = No faults are active.
5	Local Control Active	Local control active status signal. True = Converter is controlled from I/O control place, False = Converter is not controlled from I/O control place.
6	I/O Control Active	I/O control active status signal. True = Converter is controlled from I/O control place, False = Converter is not controlled from I/O control place.
7	FB Control Active	Fieldbus control active status signal. True = Converter is controlled from Fieldbus control place, False = Converter is not controlled from Fieldbus control place.
8	Warning Active (Toggled)	Toggled warning active status signal. This signal will toggle down for 1 second, whenever a new warning is activated while another warning was already active.
9	Fault Active (Toggled)	Toggled fault active status signal. This signal will toggle down for 1 second, whenever a new fault is activated while another fault was already active.
10	CTW Bit 12	Fieldbus Control word - bit 12.
11	CTW Bit 13	Fieldbus Control word - bit 13.
12	CTW Bit 14	Fieldbus Control word - bit 14.
13	CTW Bit 15	Fieldbus Control word - bit 15.
14	DC-link Voltage Supervision	

P 2.5.2.2 Delayed Output 1 On Delay No. 8036

Set the on delay for the delayed digital output 1.

P 2.5.2.3 Delayed Output 1 Off Delay No. 8038

Set the off delay for the delayed digital output 1.

P 2.5.2.4 Delayed Output 1 Output **No. 8040**

Select the output for transmitting the delayed digital output 1.

P 2.5.2.5 Delayed Output 2 Content Sel. **No. 8033**

Select the function for the delayed digital output 2. The selection list is the same as for Delayed Output 1 Content Sel.

P 2.5.2.6 Delayed Output 2 On Delay **No. 8037**

Set the on delay for the delayed digital output 2.

P 2.5.2.7 Delayed Output 2 Off Delay **No. 8039**

Set the off delay for the delayed digital output 2.

P 2.5.2.8 Delayed Output 2 Output **No. 8041**

Select the output for transmitting the delayed digital output 2.

7.3.10.3 Analog outputs (Menu Index 2.5.3)

P 2.5.3.1 DC-link Voltage Output **No. 2454**

Select an analog output for the DC-link voltage signal.

P 2.5.3.2 DC-link Voltage Output Max. **No. 2460**

Set the maximum DC-link voltage value for analog output scaling maximum.

P 2.5.3.3 DC-link Voltage Output Min. **No. 2461**

Set the minimum DC-link voltage value for analog output scaling minimum.

P 2.5.3.4 DC-link Current Output **No. 2465**

Select an analog output for the DC-link current -signal.

P 2.5.3.5 DC-link Current Output Max. **No. 2466**

Set the maximum DC-link current value for analog output scaling maximum.

P 2.5.3.6 DC-link Current Output Min. **No. 2467**

Set the minimum DC-link current value for analog output scaling minimum.

P 2.5.3.7 Source Current Output **No. 5996**

Select an analog output for the source current.

P 2.5.3.8 Source Current Output Min. **No. 5992**

Set the minimum percentage value for scaling analogue source current output.

P 2.5.3.9 Source Current Output Max. **No. 5999**

Set the maximum percentage value for scaling analogue source current output.

P 2.5.3.10 Source Voltage Output **No. 6999**

Select an analog output for the source voltage.

P 2.5.3.11 Source Voltage Output Max. **No. 7998**

Set the maximum percentage value for scaling analogue source voltage output.

P 2.5.3.12 Source Voltage Output Min. **No. 8998**

Set the minimum percentage value for scaling analogue source voltage output.

P 2.5.3.13 Source Power Output **No. 6968**

Select an analog output for the source power -signal.

P 2.5.3.14 Source Power Output Min. **No. 6969**

Set the minimum source power value for analog output scaling to a minimum.

P 2.5.3.15 Source Power Output Max. **No. 6970**

Set the maximum source power value for maximum analog output scaling.

7.3.11 Start and Stop Settings (Menu Index 2.6)

The start and stop settings group defines the parameters which must be configured to define the start and stop behavior of the converter. There are 2 start and run interlocks. These are Run Enable, and No Quick Stop Active. All the interlocks need to be true before the converter can start modulation. In addition to that, there is an additional interlock Switch On Enable from fieldbus. If any of the interlocks are removed in the run state, then it will stop the converter.

7.3.11.1 Start Settings (Menu Index 2.6.1)

P 2.6.1.1 Start Delay No. 4718

Set a delay to start the converter. The parameter can be set if there are multiple converters connected on the same dc bus to delay the start.

P 2.6.1.2 Run Enable Input No. 103

Select an input for enabling the converter to run. Run Enable is a mandatory signal for the converter to run. If removed in the run state, then it will stop the converter and the converter will not go into run state without issuing this signal back.

7.3.11.2 Stop Settings (Menu Index 2.6.2)

P 2.6.2.1 Stop Ramp Time No. 2970

Set a delay to start the converter. The parameter can be set if there are multiple converters connected on the same dc bus to delay the start.

7.3.11.3 Quick Stop (Menu Index 2.6.3)

The purpose of quick stop is to stop the converter, regardless of the operation condition. A common use case for quick stop is to allow the converter to make a controlled stop when the Emergency Stop button is pressed. Usually, there are a few seconds to make a controlled stop before an emergency stop forces all breakers to open and makes the system electrically safe.

P 2.6.2.1 Quick Stop Input No. 212

Select an input for the Quick Stop function. Quick Stop is activated when this input becomes FALSE. In addition to stopping the unit,

P 2.6.2.2 Quick Stop Input 2 No. 5104

Select an input for the Quick Stop function. Quick Stop is activated when this input becomes FALSE. In addition to stopping the unit,

P 2.6.2.3 Quick Stop Response No. 4587

Select the response to a Quick Stop event. Regardless of the selected response, in addition to stopping the unit, the Quick Stop function will open the main circuit breaker (if controlled by the converter).

The following are the selections for the parameter.

Selection Number	Name	Description
0	No response	The event is ignored.
1	Info	The event is logged in the event log.
3	Warning	The drive issues a warning.
9	Fault, Power Ramp Down	A fault is issued, the current is ramped down and then the modulation is stopped
10	Fault	A fault is issued and the modulation is stopped .

7.3.12 Control Places (Menu Index 2.7)

The DC/DC Converter application features four different control places for determining how basic converter commands and references are interfaced. These control places are the MyDrive® Insight (PC Control), Local Control (via control panel), Fieldbus Control and I/O Control.

Selection:

There are two methods for selecting which control place is active, or in other words in command of the converter. The first is a simple parameter selection, while the second is a set of signals that can be used to force or request for a specific control place to be in command.

Commands:

A control place is a source for basic control commands (start, stop, reset, and so on). When operating for instance in I/O control, the converter cannot be started from the local or fieldbus control places. Control places do not dictate all possible commands. Note that specific features such as Quick Stop can be used regardless of the control place and must be configured separately.

Control Place Settings

This group contains general control place settings that mainly have to do with control place selection. The figure below presents the control place selection chain diagram. The default method for choosing the control place is by using the parameter No. 114 Control Place Selection. It can be used to select the active control place between Local, Fieldbus and I/O control.

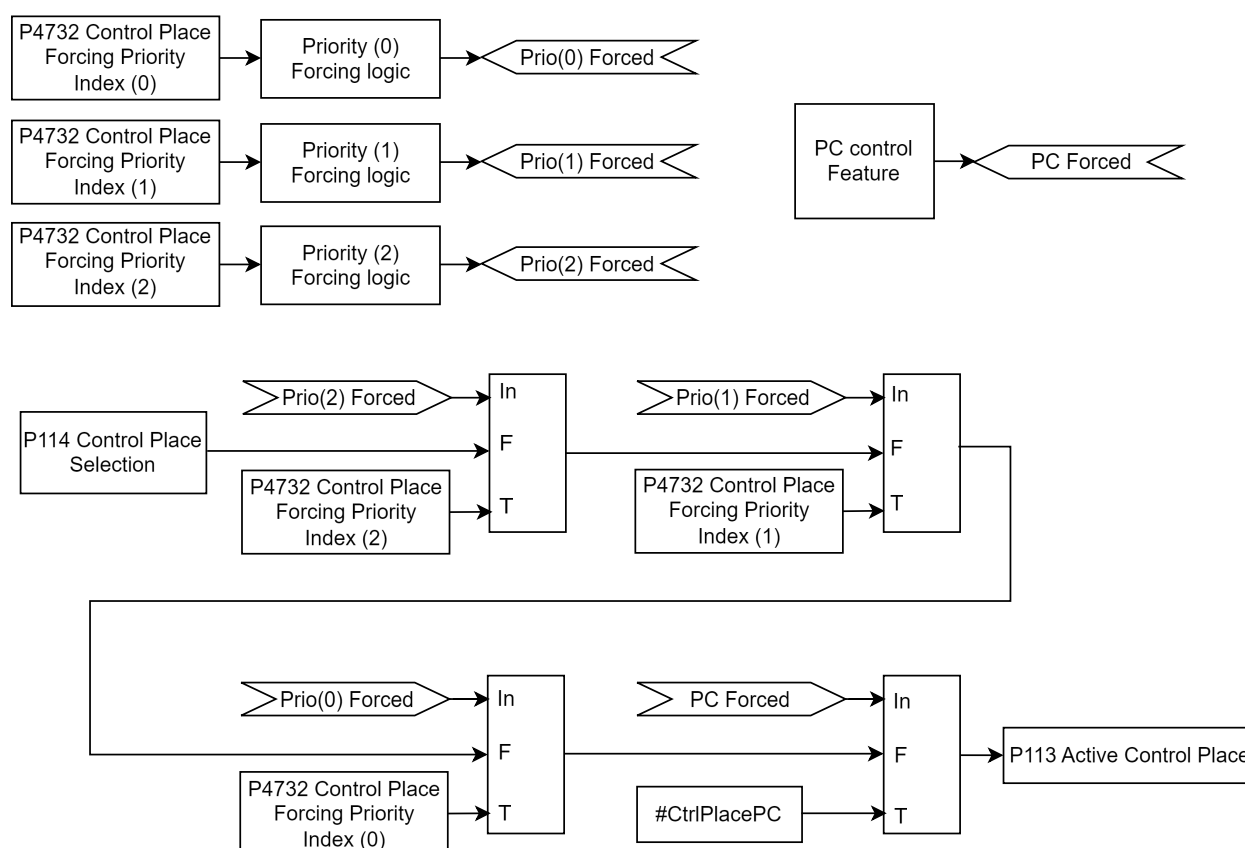

Illustration 20: Control Place Priority Chain

The second option for control place selection is to use control place forcing signals, which will override the selection made with the parameter, and can be used to swap between different control places, for example, via external push buttons or switches. The forcing signals for Fieldbus and I/O control can be mapped to digital inputs or fieldbus, and the Local control forcing is activated with the REM/LOC button of the control panel.

The priority order for the forceable control places is configured with parameter No. 4732. The priority order affects the final control place selection if two or more control places are forced on simultaneously. For example: if Fieldbus is selected for highest priority with Index-0, and I/O for the next highest priority with index-1, and both control places are forced on simultaneously, fieldbus is selected as the active control place. After Fieldbus forcing is removed the control place will fall to I/O because it has higher priority than the parameter selection.

The only control place which can take over the control from any other control place regardless of forcing inputs is the MyDrive® Insight. Control is overtaken by requesting it via the tool itself. By default, the converter uses the following control place priority order:

MyDrive® Insight > Local Control > I/O > Fieldbus > Parameter Selection

Forcing can be further configured with parameter No. 1972 which defines whether each forcing signal is treated as a state sensitive or toggled signal.

Parameter No. 4800 can be used to define how the converter should behave when an active control place releases control. The options are to either release control immediately or only if another control place requests control.

When a control place is changed, the converter will either stop or continue operating (modulation) based on the settings defined with parameters No. 108, No. 5112, and No. 5111, respectively for each control place.

7.3.12.1 Control Place Settings (Menu Index 2.7.1)

P 2.7.1.1 Control Place Selection **No. 114**

Select the active control place.

The following are the selections for the parameter.

Number	Name
0	PC control
1	Local Control
2	Fieldbus control
3	I/O Control

P 2.7.1.2 Force FB Control Input **No. 4511**

Select an input for forcing the control place to Fieldbus.

P 2.7.1.3 Force I/O Control Input **No. 4513**

Select an input for forcing the control place to I/O.

P 2.7.1.4 Control Place Forcing Mode **No. 1972**

Select whether each control place forcing signal is treated as a state sensitive or a toggled signal.

The following are the selections for the parameter.

Number	Name
0	FB: State I/O: State
1	FB: Toggle I/O: State
2	FB: State I/O: Toggle
3	FB: Toggle I/O: Toggle

P 2.7.1.5 Control Place Independent Reset **No. 109**

Enable faults to be reset from all control places.

The following are the selections for the parameter.

Number	Name
0	Disabled
1	Enabled

P 2.7.1.6 Control Place Release Mode No. 4800

Select the action after the control place is released from the forced control places, as well as from control panel or PC control. When set to "Change After Release" the control place is changed after releasing to other forced place highest in priority order, or in case no forced places are used, to the place defined with parameter "Control Place Selection". When set to "Retain After Release" the control place is not changed after releasing, but only after the control place is changed by forcing or from parameter "Control Place Selection".

The following are the selections for the parameter.

Selection Number	Name	Description
0	Retain After Release	Control place is retained after releasing.
1	Change After Release	Control place is changed after releasing.

P 2.7.1.7 Control Place Forcing Priority No. 4732

Set the control place priority when using control place forcing inputs. The priority is specified in decreasing order. Therefore, in case multiple control places are requested simultaneously, the selection made with Index 0 prevails on the selection made with Index 1, and so on. If a control place is not assigned any priority, its forcing signal is disabled.

The following are the selections for the parameter.

Selection Number	Name
0	PC control
1	Local Control
2	Fieldbus control
3	I/O Control

7.3.12.2 Local Control (Menu Index 2.7.2)
P 2.7.2.1 Local Control Mode No. 107

Select restrictions of local control by the control panel.

The following are the selections for the parameter.

Selection Number	Name	Description
0	Allow Local Control	Local mode from control panel is enabled.
1	Deny Local Start	Start in local mode from control panel is disabled.
2	Deny Local Control	Local mode from control panel is disabled.

P 2.7.2.2 Continue Operation in Local Control No. 108

Select whether the start request is retained when the converter is running, and the control place is changed to local control.

The following are the selections for the parameter.

Selection Number	Name
0	Disabled
1	Enabled

7.3.12.3 I/O Control (Menu Index 2.7.3)

P 2.7.3.1 I/O Start Input No. 200

Select an input for starting the unit when the active control place is I/O Control.

P 2.7.3.2 I/O Stop Input No. 201

Select an input for stopping the unit when the active control place is I/O Control. Stop is activated when this input becomes FALSE.

P 2.7.3.3 I/O Reset Input No. 203

Select an input for the warning/fault reset when the active control place is I/O Control. The dependence on control place is selected based on Control Place Independent Reset (No. 109).

P 2.7.3.4 I/O Start Mode No. 213

Select whether start commands for I/O control are state, rising edge or pulse sensitive.

The following are the selections for the parameter.

Selection Number	Name	Description
0	State High Start	Start command remains as long as input is true.
1	Rising Edge Start	Start command is set when input becomes true and remains latched until stop command is given or input becomes false. Start command does not remain latched over a stop, even if start input is kept true.
2	High Pulse Start	Start command is set when input becomes true and remains latched until stop command is given.

P 2.7.3.5 Continue Operation in I/O Control No. 5111

Select whether the start request is retained when the drive is running and the control place is changed to I/O, while using edge-sensitive start modes. Note that any active stop command or auxiliary function such as quick stop may still prohibit continuing operation.

The following are the selections for the parameter.

Selection Number	Name
0	Disabled
1	Enabled

7.3.12.4 Fieldbus Control (Menu Index 2.7.4)

P 2.7.4.1 Continue Operation in Fieldbus Control No. 5112

Select whether the start request is retained when the drive is running, and the control place is changed to fieldbus. Note that any active stop command or auxiliary function such as quick stop may still prohibit continuing operation. Note also that continuation is possible only if the start is requested from fieldbus before the control place is changed to it.

The following are the selections for the parameter.

Selection Number	Name
0	Disabled
1	Enabled

P 2.7.4.2 Fieldbus Start Mode
No. 5114

Select whether start commands for Fieldbus Control are state or rising-edge sensitive.

The following are the selections for the parameter.

Selection Number	Name	Description
0	State High Start	Start command remains as long as input is true.
1	Rising Edge Start	Start command is set when input becomes true and remains latched until stop command is given or input becomes false. Start command does not remain latched over a stop, even if start input is kept true.

7.3.13 Converter Control (Menu Index 2.8)

7.3.13.1 Modulation (Menu Index 2.8.1)

This group contains parameters for fine-tuning modulation settings.

P 2.8.1.1 Switching Frequency
No. 2920

Set the switching frequency.

P 2.8.1.2 Modulator Options
No. 5093

Advanced modulator options.

Selection Number	Name
0	Disable compensation of non-linearities.
1	Disable deadtime compensation based on feedback.
2	Use filtered DC voltage over whole speed range.
3	Prohibit pulse dropping when reaching voltage ceiling.
4	Optimized minimum pulse logic for carrier synchronization.

P 2.8.1.3 Forward Voltage Compensation **No. 6518**

Forward voltage-drop compensation of the converter.

7.3.13.1.1 Advanced DC Source Control (Menu Index 2.8.2)
 **WARNING**

Advanced DC Source Control parameters must not be changed without consulting Danfoss Drives Service personal.

P 2.8.2.1 Current Controller Kp **No. 8021**

Set the scaling of the current controller nominal proportional gain.

P 2.8.2.2 Current Controller Ti **No. 8022**

Set the scaling of the current controller nominal integral time.

P 2.8.2.3 DC Source Voltage Control Kp **No. 6256**

Scaling of internally computed source voltage control proportional gain.

P 2.8.2.4 DC Source Voltage Control Ti **No. 6527**

Scaling of internally computed source voltage control integral time.

P 2.8.2.5 DC Source Voltage Control Td **No. 6575**

Scaling of internally computed source voltage control derivative time.

7.3.13.2 Advanced DC-link Control (Menu Index 2.8.3)
 **WARNING**

Advanced DC-Link Control parameters must not be changed without consulting Danfoss Drives Service personal.

P 2.8.3.1 DC-link Voltage Ctrl. Kp **No. 2902**

Scaling of internally computed DC-link voltage control proportional gain.

P 2.8.3.2 DC-link Voltage Ctrl. Ti **No. 2903**

Scaling of internally computed DC-link voltage control integral time.

P 2.8.3.3 DC-link Voltage Ctrl. Td **No. 2907**

Scaling of internally computed DC-link voltage control differential time.

P 2.8.3.4 DC-link Voltage Droop. Tc **No. 5095**

Filtering time constant of active current when DC-link voltage drooping is used.

P 2.8.3.8 Overvoltage Control Kp **No. 1803**

Set the scaling of the overvoltage control proportional gain.

P 2.8.3.9 Overvoltage Control Ti **No. 1804**

Set the scaling of the overvoltage control integral time.

P 2.8.3.10 Overvoltage Control Td **No. 1805**

Set the scaling of the overvoltage control derivation time.

P 2.8.3.11 Undervoltage Control Kp **No. 1806**

Set the scaling of the undervoltage control proportional gain.

P 2.8.3.12 Undervoltage Control Ti **No. 1807**

Set the scaling of the undervoltage control integral time.

P 2.8.3.13 Undervoltage Control Td **No. 1808**

Set the scaling of the undervoltage control derivation time.

7.3.13.3 Power Unit Settings (Menu Index 2.8.4)

P 2.8.4.1 Power Unit Enable Mask No. 2835

Select which of the commissioned power units are enabled.

The value is given bitwise per each unit. Bit 0 corresponds to the first port in the Star coupler board, and bit 15 to the 16th port and so on. An active bit enables the corresponding power unit, and an inactive bit disables it.

This parameter is relevant only for drives with multiple power units, connected to the control board with the Star coupler board. Faulty or redundant power units can be disabled temporarily to allow running with reduced capacity. All internal protection functions adjust to the amount of enabled power units.

WARNING

Please consult Danfoss Drives Service personnel before modifying Power Unit Enable Mask settings. Depending on the system's hardware configuration, it might be necessary to galvanically isolate the disabled units and all associated filters from the system. Failing to do so may increase the risk of resonance and damage the rest of the system.

NOTICE

This parameter cannot be edited when the converter is running.

NOTICE

After Factory Reset or Node Commissioning the drive will automatically set this parameter to activate the nominal number of power units starting sequentially from the first port of the Star coupler board. If the drive has several power units, but this parameter does not have the correct value at initial start, it is recommended to run Factory Reset and power-cycle the drive. This operation will reset the Power Unit Enable Mask to correspond with the nominal amount of power units.

P 2.8.4.2 DC-link Voltage Measurement Corr. Gain No. 6535

Set the DC-link voltage measurement correction gain for parallel units.

P 2.8.4.3 DC-link Voltage Measurement Corr. Offset No. 6534

Set the DC-link voltage measurement correction offset for parallel units.

P 2.8.4.4 HF DC-link Filter Mode No. 2944

Select the mode of the high-frequency filter in the DC link.

The following are the selections for the parameter.

Selection Number	Name
0	Filter inactive
1	Filter active

7.3.13.4 Cooling Fan Control (Menu Index 2.8.5)

Cooling fan control is only possible for the air-cooled converters.

P 2.8.5.1 Main Fan Minimum Speed No. 2932

Set the minimum speed of the main cooling fan.

P 2.8.5.2 Internal Fan Minimum Speed No. 2928

Set the minimum speed of the internal cooling fan.

7.3.13.5 LCL-Filter (Menu Index 2.8.6)

P 2.8.6.1 LCL Filter L1 No. 2904

Set the converter side filter inductance.

P 2.8.6.2 LCL Filter Cf No. 2905

Set the filter capacitance.

P 2.8.6.3 LCL Filter R1 No. 6521

Set the converter side filter inductor series resistance.

7.3.14 Protections and Responses (Menu Index 2.9)

7.3.14.1 General Settings (Menu Index 2.9.1)

P 2.9.1.1 Retry after Fault No. 2927

Enables retry functionality (ride-through) functionality for the following fault type events. The number of retry attempts and the retry window depend on the event and the size and rating of the power unit.

The following are the selections for the parameter.

Selection Number	Name
0	Disabled
1	Enabled

7.3.14.2 Misc. Responses (Menu Index 2.9.2)

P 2.9.2.1 DC-link Voltage Ripple Response No. 2929

Select the mode of excessive DC-link voltage ripple protection. Excessive voltage ripples are detected when the peak-to-peak amplitude of the DC voltage exceeds the converter's internal limit for too long a time. Both the limit and time depend on the power unit type and rating.

The following are the selections for the parameter.

Number	Name	Description
0	Disabled	Effectively nothing is done when excessive rippling is detected.
1	Fault	After detecting excessive ripples for too long, the converter will issue a fault and stop modulation.
2	Automatically derate + Fault	After detecting excessive ripples, the converter will derate the maximum allowed output frequency. If the derating does not reduce the rippling soon enough, the converter will issue a fault and stop modulation. The derating is released if the ripple amplitude is reduced below the detection limit.

P 2.9.2.2 LCL Fan Fail Response No. 2941

Select the drive response to an LCL Fan Fail.

The following are the selections for the parameter.

Number	Name	Description
0	No response	-
1	Info	The converter will issue an info event.
3	Warning	The converter will issue a warning event.
10	Fault	The converter will issue a fault event and stop modulation.

7.3.14.3 External Event (Menu Index 2.9.3)

External events are protection functions which can be configured to trigger converter events (warnings, faults, and so on) through inputs. Two separate events are available, both can be triggered with an active-high or active-low signals.

P2.9.3.1 External Event 1 Input No. 4557

Select an input for the external event.

P2.9.3.3 External Event 1 Response No. 4559

Select the response to an external event.

No.	Name	Description
0	No response	-
1	Info	The converter will issue an info event.
3	Warning	The converter will issue a warning event.
10	Fault	The converter will issue a fault event and stop modulation.

P2.9.3.3 External Event 2 Input No. 4560

Select an input for the external event.

P2.9.3.4 External Event 2 Response No. 4562

Select the response to an external event.

No.	Name	Description
0	No response	-
1	Info	The converter will issue an info event.
3	Warning	The converter will issue a warning event.
10	Fault	The converter will issue a fault event and stop modulation.
11	Fault, Open MCB	The converter will issue a fault event, stop modulation, and open the main circuit breaker.

7.3.14.3.1 Cooling Monitor (Menu Index 2.9.4)

The cooling monitor feature is relative for liquid cooled converters. It is designed to allow the converter to receive a single digital signal from the cooling unit when it experiences errors. The converter will then act as configured.

P2.9.4.1 Cooling Monitor Input No. 2400

Select the input for the negated cooling monitor signal.

P2.9.4.2 Cooling Monitor Fault Delay No. 2401

Set a delay before the cooling monitor issues a fault. Only valid if fault is selected.

P2.9.4.3 Cooling Monitor Response No. 2402

Select the response to a missing cooling monitor signal. The response is selected for both stopped and running states.

Number	Name	Description
0	Warning while running	The converter issues a warning if the cooling signal is lost, and the converter is running.
1	Warning	The converter issues a warning if the cooling signal is lost.
2	Warning, Fault after Timeout while running	The converter issues a warning if the cooling signal is lost. If the converter is running the event is escalated into a fault after the fault delay (No. 2401).

Number	Name	Description
3	Warning and Fault after Timeout while running	The converter issues a warning if the cooling signal is lost, and the converter is running. After the fault delay (No. 2401) the event is escalated into a fault.

7.3.14.4 Measured Temp. Protection

The measured temperature protection offers 10 individual protection channels for monitoring temperatures of external devices like filters or motor windings through temperature probes. Each protection can be configured to trigger an individual event, which can be used to identify the source of the high temperature measurement.

Each protection has two configurable stages, as illustrated in the figure below. Stage 1 is used to trigger a warning, while stage 2 can be used to trigger a more severe event, which may possibly stop the converter (fault). The activation levels of both stages and the event response of stage 2 can be configured. The levels of both stages can be configured to be the same, if two stages are unnecessary.

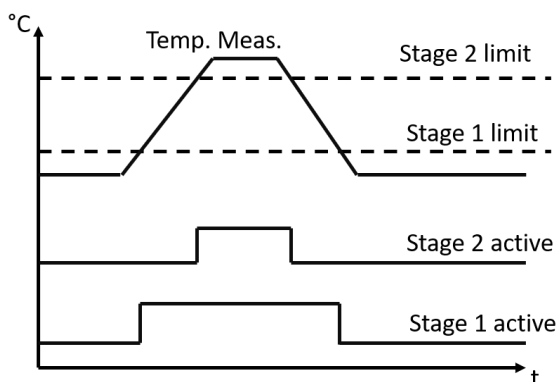

Illustration 21: Operating principle of measured temperature protection

Additionally, a temperature measurement range check feature is also available, as presented in the figure below. A range can be defined for checking the validity of each measured temperature protection. If the absolute measurement value of any protection exceeds this range, a separate event can be triggered.

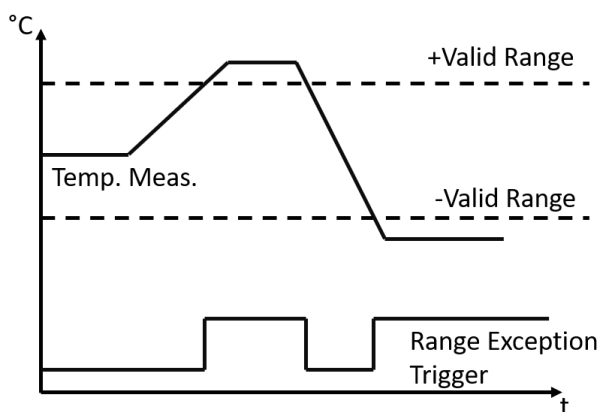

Illustration 22: Operating principle of temperature measurement range

Temp. 1 Protection

P2.9.5.1.1 Temp. 1 Input **No. 5206**

Select the temperature sensor input for the temperature protection.

P2.9.5.1.2 Temp. 1 Limit 1 **No. 5207**

Set the temperature level for issuing a warning.

P2.9.5.1.3 Temp. 1 Limit 2 No. 5208

Set the temperature level for issuing a protection response.

P2.9.5.1.4 Temp. 1 Limit 2 Response No. 5209

Select the response for exceeding the limit.

Number	Name	Description
0	No response	-
1	Info	The converter will issue an info event.
3	Warning	The converter will issue a warning event.
10	Fault	The converter will issue a fault event and stop modulation.

7.3.14.4.1 Temp. 2 Protection
P2.9.5.2.1 Temp. 2 Input No. 5210

Select the temperature sensor input for the temperature protection.

P2.9.5.2.2 Temp. 2 Limit 1 No. 5211

Set the temperature level for issuing a warning.

P2.9.5.2.3 Temp. 2 Limit 2 No. 5212

Set the temperature level for issuing a protection response.

P2.9.5.2.4 Temp. 2 Limit 2 Response No. 5213

Select the response for exceeding the limit.

Number	Name	Description
0	No response	-
1	Info	The converter will issue an info event.
3	Warning	The converter will issue a warning event.
10	Fault	The converter will issue a fault event and stop modulation.

7.3.14.4.2 Temp. 3 Protection
P2.9.5.3.1 Temp. 3 Input No. 5214

Select the temperature sensor input for the temperature protection.

P2.9.5.3.2 Temp. 3 Limit 1 No. 5215

Set the temperature level for issuing a warning.

Number	Name	Description
0	No response	-
1	Info	The converter will issue an info event.
3	Warning	The converter will issue a warning event.
10	Fault	The converter will issue a fault event and stop modulation.

P2.9.5.3.3 Temp. 3 Limit 2 No. 5216

Set the temperature level for issuing a protection response.

P2.9.5.3.4 Temp. 3 Limit 2 Response No. 5217

Select the response for exceeding the limit.

Number	Name	Description
0	No response	-
1	Info	The converter will issue an info event.
3	Warning	The converter will issue a warning event.
10	Fault	The converter will issue a fault event and stop modulation.

7.3.14.4.3 Temp. 4 Protection
P2.9.5.4.1 Temp. 4 Input No. 5218

Select the temperature sensor input for the temperature protection.

P2.9.5.4.2 Temp. 4 Limit 1 No. 5219

Set the temperature level for issuing a warning.

P2.9.5.4.3 Temp. 4 Limit 2 No. 5220

Set the temperature level for issuing a protection response.

P2.9.5.4.4 Temp. 4 Limit 2 Response No. 5221

Select the response for exceeding the limit.

Number	Name	Description
0	No response	-
1	Info	The converter will issue an info event.
3	Warning	The converter will issue a warning event.
10	Fault	The converter will issue a fault event and stop modulation.

7.3.14.4.4 Temp. 5 Protection
P2.9.5.5.1 Temp. 5 Input No. 5222

Select the temperature sensor input for the temperature protection.

P2.9.5.5.2 Temp. 5 Limit 1 No. 5223

Set the temperature level for issuing a warning.

P2.9.5.5.3 Temp. 5 Limit 2 No. 5224

Set the temperature level for issuing a protection response.

P2.9.5.5.4 Temp. 5 Limit 2 Response No. 5225

Select the response for exceeding the limit.

Number	Name	Description
0	No response	-
1	Info	The converter will issue an info event.
3	Warning	The converter will issue a warning event.
10	Fault	The converter will issue a fault event and stop modulation.

7.3.14.4.5 Temp. 6 Protection

P2.9.5.6.1 Temp. 6 Input **No. 5226**

Select the temperature sensor input for the temperature protection.

P2.9.5.6.2 Temp. 6 Limit 1 **No. 5227**

Set the temperature level for issuing a warning.

P2.9.5.6.3 Temp. 6 Limit 2 **No. 5228**

Set the temperature level for issuing a protection response.

P2.9.5.6.4 Temp. 6 Limit 2 Response **No. 5229**

Select the response for exceeding the limit.

Number	Name	Description
0	No response	-
1	Info	The converter will issue an info event.
3	Warning	The converter will issue a warning event.
10	Fault	The converter will issue a fault event and stop modulation.

7.3.14.4.6 Temp. 7 Protection

P2.9.5.7.1 Temp. 7 Input **No. 5239**

Select the temperature sensor input for the temperature protection.

P2.9.5.7.2 Temp. 7 Limit 1 **No. 5243**

Set the temperature level for issuing a warning.

P2.9.5.7.3 Temp. 7 Limit 2 **No. 5269**

Set the temperature level for issuing a protection response.

P2.9.5.7.4 Temp. 7 Limit 2 Response **No. 5235**

Select the response for exceeding the limit.

No.	Name	Description
0	No response	-
1	Info	The converter will issue an info event.
3	Warning	The converter will issue a warning event.
10	Fault	The converter will issue a fault event and stop modulation.

7.3.14.4.7 Temp. 8 Protection

P2.9.5.8.1 Temp. 8 Input **No. 5240**

Select the temperature sensor input for the temperature protection.

P2.9.5.8.2 Temp. 8 Limit 1 **No. 5247**

Set the temperature level for issuing a warning.

P2.9.5.8.3 Temp. 8 Limit 2 **No. 5270**

Set the temperature level for issuing a protection response.

P2.9.5.8.4 Temp. 8 Limit 2 Response No. 5236

Select the response for exceeding the limit.

Number	Name	Description
0	No response	-
1	Info	The converter will issue an info event.
3	Warning	The converter will issue a warning event.
10	Fault	The converter will issue a fault event and stop modulation.
11	Fault, Open MCB	The converter will issue a fault event, stop modulation, and open the main circuit breaker.

7.3.14.4.8 Temp. 9 Protection
P2.9.5.9.1 Temp. 9 Input No. 5241

Select the temperature sensor input for the temperature protection.

P2.9.5.9.2 Temp. 9 Limit 1 No. 5249

Set the temperature level for issuing a warning.

P2.9.5.9.3 Temp. 9 Limit 2 No. 5271

Set the temperature level for issuing a protection response.

P2.9.5.9.4 Temp. 9 Limit 2 Response No. 5237

Select the response for exceeding the limit.

Number	Name	Description
0	No response	-
1	Info	The converter will issue an info event.
3	Warning	The converter will issue a warning event.
10	Fault	The converter will issue a fault event and stop modulation.

7.3.14.4.9 Temp. 10 Protection
P2.9.5.10.1 Temp. 10 Input No. 5242

Select the temperature sensor input for the temperature protection.

P2.9.5.10.2 Temp. 10 Limit 1 No. 5268

Set the temperature level for issuing a warning.

P2.9.5.10.3 Temp. 10 Limit 2 No. 5272

Set the temperature level for issuing a protection response.

P2.9.5.10.4 Temp. 10 Limit 2 Response No. 5238

Select the response for exceeding the limit.

Number	Name	Description
0	No response	-
1	Info	The converter will issue an info event.
3	Warning	The converter will issue a warning event.
10	Fault	The converter will issue a fault event and stop modulation.

7.3.14.4.10 Common

P2.9.5.11.1 Meas. Valid Range **No. 5230**

Set a valid reading range for the temperature probe measurements. The first element of the array is the higher and the second element the lower limit. An event is triggered if 1 of the readings goes above the higher, or below the lower limit.

P2.9.5.11.2 Meas. Out of Range Response **No. 5231**

Select the converter response when 1 or more of the probes exceed the valid range.

Number	Name	Description
0	No response	-
1	Info	The converter will issue an info event.
3	Warning	The converter will issue a warning event.
10	Fault	The converter will issue a fault event and stop modulation.

7.3.14.5 Thermistor Monitoring

The thermistor monitoring function provides three input channels that can be connected to a Positive Temperature Coefficient (PTC) type sensor. After a threshold of 4 kilo-ohms is exceeded in the input, an event is triggered. The event response is configurable.

P2.9.6.1 Thermistor Monitoring Response No. 5232

Select the response to all thermistor monitoring events.

Number	Name	Description
0	No response	-
1	Info	The converter will issue an info event.
3	Warning	The converter will issue a warning event.
10	Fault	The converter will issue a fault event and stop modulation.
11	Fault, Open MCB	The converter will issue a fault event, stop modulation, and open the main circuit breaker.

P2.9.6.2 Thermistor Monitor 1 Input **No. 1520**

Select a thermistor input for the thermistor monitor 1.

Number	Name	Description
0	None (False)	No input is selected. A virtual value of FALSE is applied.
1	None (True)	No input is selected. A virtual value of TRUE is applied.
*	Available thermistor input terminals	A dynamically generated selection of available thermistor input terminals is presented as an option. The specific set depends on the type and number of I/O options installed in the system.

P2.9.6.3 Thermistor Monitor 2 Input No. 1522

Select a thermistor input for the thermistor monitor 2.

Number	Name	Description
0	None (False)	No input is selected. A virtual value of FALSE is applied.
1	None (True)	No input is selected. A virtual value of TRUE is applied.
*	Available thermistor input terminals	A dynamically generated selection of available thermistor input terminals is presented as an option. The specific set depends on the type and number of I/O options installed in the system.

P2.9.6.4 Thermistor Monitor 3 Input No. 1524

Select a thermistor input for the thermistor monitor 3.

Number	Name	Description
0	None (False)	No input is selected. A virtual value of FALSE is applied.
1	None (True)	No input is selected. A virtual value of TRUE is applied.
*	Available thermistor input terminals	A dynamically generated selection of available thermistor input terminals is presented as an option. The specific set depends on the type and number of I/O options installed in the system.

7.3.14.6 Live Zero (Menu Index 2.9.7)
P 2.9.7.1 Live Zero Response

This parameter is used for selecting the converter generic behavior if at least one of the analog inputs has gone below the set threshold value.

Select the drive response to a missing input signal (live zero).

The following are the selections for the parameter.

Number	Name	Description
0	No response	The event is ignored.
1	Info	The event is logged in the event log.
3	Warning	The drive issues a warning.
13	Warning, Current Lim. Ramp - Persistent	A warning is issued, and the pos./neg. active current limits are ramped to preset values. The current limit overrides stay active until the warning is acknowledged by a reset.
10	Fault	A fault is issued, and the modulation is stopped.

7.3.14.7 Fieldbus Protections (Menu Index 2.9.8)

This group contains parameters for setting responses, delays, and other settings for fieldbus related protections.

P 2.9.8.1 Fieldbus Fault Response

Select the behavior when a fieldbus fault occurs.

The following are the selections for the parameter.

Number	Name	Description
0	No response	The event is ignored.
1	Info	The event is logged in the event log.
3	Warning	The drive issues a warning.
13	Warning, Current Lim. Ramp - Persistent	A warning is issued, and the pos./neg. active current limits are ramped to preset values. The current limit overrides stay active until the warning is acknowledged by a reset.
10	Fault	A fault is issued, and the modulation is stopped.

P 2.9.8.2 No Fieldbus Connection Response

Select the response in case there is no fieldbus connection.

The following are the selections for the parameter.

Number	Name	Description
0	No response	The event is ignored.
1	Info	The event is logged in the event log.
3	Warning	The drive issues a warning.
13	Warning, Current Lim. Ramp - Persistent	A warning is issued, and the pos./neg. active current limits are ramped to preset values. The current limit overrides stay active until the warning is acknowledged by a reset.
10	Fault	A fault is issued, and the modulation is stopped.

P 2.9.8.3 Process Data Timeout Response

Select the response to a process data timeout.

The following are the selections for the parameter.

Number	Name	Description
0	No response	The event is ignored.
1	Info	The event is logged in the event log.
3	Warning	The drive issues a warning.
13	Warning, Current Lim. Ramp - Persistent	A warning is issued, and the pos./neg. active current limits are ramped to preset values. The current limit overrides stay active until the warning is acknowledged by a reset.
10	Fault	A fault is issued, and the modulation is stopped.

P 2.9.8.4 Process Data Timeout Delay

Set a delay for the triggering of the Process Data Timeout event. If process data hasn't been updated within this delay time the event is triggered.

P 2.9.8.5 Fieldbus Watchdog Response

Select the drive response for the fieldbus watchdog event.

The following are the selections for the parameter.

Number	Name	Description
0	No response	The event is ignored.
1	Info	The event is logged in the event log.
3	Warning	The drive issues a warning.
13	Warning, Current Lim. Ramp - Persistent	A warning is issued, and the pos./neg. active current limits are ramped to preset values. The current limit overrides stay active until the warning is acknowledged by a reset.
10	Fault	A fault is issued, and the modulation is stopped.

P 2.9.8.6 Fieldbus Watchdog Delay

Set a delay for activating the fieldbus watchdog event.

P 2.9.8.7 Fieldbus Watchdog Start Delay

Set start-up delay time for activating the fieldbus watchdog event. Counter begins when converter wakes up.

7.3.14.8 HMI Connection Loss (Menu Index 2.9.9)

Selects the converter response for losing connection to MyDrive® Insight or the control panel while they are in control of the converter. Regardless of the response, the control is released to the control place with the next highest control priority.

P2.9.8.1 HMI Connection Loss **No. 5420**

Select the response after lost connection to control panel or PC tool while they are in control. The timeout occurs after 5 s.

The following are the selections for the parameter.

Number	Name	Description
0	No response	The event is ignored.
2	Info	The event is logged in the event log.
4	Warning - Persistent	The drive issues a warning that stays active until acknowledged by a reset.
10	Fault	A fault is issued, and the modulation is stopped.

7.3.14.9 Cooling Fan Supervision (Menu Index 2.9.10)

P 2.9.10.1 Main Fan Fail Response **No. 2939**

Select the drive response to a main fan fail.

The following are the selections for the parameter.

Number	Name	Description
0	No response	The event is ignored.
1	Info	The event is logged in the event log.
3	Warning	The drive issues a warning.
10	Fault	A fault is issued, and the modulation is stopped.

P 2.9.10.2 Internal Fan Fail Response No.2940

Select the drive response to an internal fan fail.

The following are the selections for the parameter.

Number	Name	Description
0	No response	The event is ignored.
1	Info	The event is logged in the event log.
3	Warning	The drive issues a warning.
10	Fault	A fault is issued, and the modulation is stopped.
11	Fault, Open MCB	A fault is issued, the modulation is stopped and the MCB is opened, if controlled by the converter.

7.3.14.10 Voltage Supervision (Menu Index 2.9.11)
P 2.9.11.1 DC Source Voltage Superv. Response No. 2962

Response in case DC source voltage supervision detects a voltage outside of the limits defined by Min. DC Source Voltage Limit and Max. DC Source Voltage Limit.

The following are the selections for the parameter.

Number	Name	Description
0	No response	The event is ignored.
1	Warning	The drive issues a warning.
2	Warning in Stop State, Fault in Run State	The response depends on the converter status: if it is running (modulating) a fault is issued, otherwise a warning is issued.
3	Fault	A fault is issued, and the modulation is stopped.

P 2.9.11.2 DC Source Voltage Superv. Delay No. 2963

Delay applied by the DC source voltage supervision. A high or low DC source voltage condition is not detected/ removed unless the voltage is outside/inside of the specified limits for at least this time.

P 2.9.11.3 DC Source Voltage Superv. Margin No. 2966

Tolerance margin on the limits applied by the DC source voltage supervision. It is expressed in % of the DC source nominal voltage.

7.3.14.11 Current Supervision (Menu Index 2.9.12)
P 2.9.12.1 DC Source Current Superv. Response

Response in case DC source current supervision detects a current outside of the limits defined by Output Current Limit, Neg. DC Source Current Limit or Pos. DC Source Current Limit.

The following are the selections for the parameter.

Number	Name	Description
0	No response	The event is ignored.
1	Warning - Run State Only	
2	Warning - Run and Stop State	

P 2.9.12.2 DC Source Current Superv. Delay No. 2965

Delay applied by the DC source current supervision. A high positive or negative DC source current condition is not detected/removed unless the current is outside/inside of the specified limits for at least this time.

P 2.9.12.3 DC Source Current Superv. Margin No. 2967

Description: Tolerance margin on the limits applied by the DC source current supervision. It is expressed in % of the DC source nominal

current.

7.4 Maintenance & Service (Menu Index 3)

This group contains auxiliary parameters for monitoring, commissioning, and servicing the converter.

7.4.1 Software Information (Menu Index 3.1)

This group houses details about the software.

P 3.1.1 Application Version

Shows the version of the application software.

7.4.2 Events (Menu Index 3.2)

When encountering issues, the converter may issue events of the Info, Warning or Fault response type. This group contains information and parameters for monitoring and simulating these events.

7.4.2.1 Active Events

This is an active events screen shown only in the control panel. Only active warnings and faults events are displayed in this screen – info events are not. With MyDrive® Insight, the same information is available in the “Events” screen. Check the available information via the control panel or MyDrive® Insight.

7.4.2.2 All Events

This is the event history screen shown only in the control panel. With MyDrive® Insight, the same information is available in the “Events” screen. Check the available information via the control panel or MyDrive® Insight.

7.4.2.3 Event Simulation (Menu Index 3.2.3)

The event simulation feature can be used to trigger any converter event without meeting the event criteria. This can be used to safely preview how the converter behaves during specific events. For instance, some events may trigger other functions, such as indications through digital outputs. This feature is useful for checking the setup, configuration, and validity of such functions during specific events.

NOTICE

This feature is for commissioning and testing purposes. It is not meant for functional use.

WARNING

This feature can stop the converter and possibly trigger external events. Do not use without proper knowledge of the system.

How to use:

1. Refer to the Events Summary Table to get the event number and details for a specific event.
2. Set the event number with parameter No. 1402.
3. Activate the simulation by setting parameter No. 1401 to the desired simulation response.
4. To end the simulation, set parameter No. 1401 back to “Disabled”.
5. If required, give a Fault Reset command to acknowledge a simulated event.
6. If required, reboot the converter to acknowledge “Trip Locked” events.

P3.2.3.1 Simulate Event No. 1400

Simulates the selected event with the selected response. Simulation begins when changing value from Disabled. To reset a simulated event, this parameter needs to be set back to Disabled first.

Number	Name	Description
0	Disabled	Event simulator is inactive
1	Lowest Response	The event selected with parameter No. 1402 is activated with its lowest event response.

Number	Name	Description
		Note that if the event can be configured with a response parameter, the response parameter's setting will apply to the simulation.
10	Highest Response	The event selected with parameter No. 1402 is activated with its highest event response. Note that if the event can be configured with a response parameter, the response parameter's setting will apply to the simulation.

P3.2.3.2 Simulate Persisting Event No. 1401

Select a response to trigger a persisting simulated event. Set back to 0 to allow a reset. Simulates the selected event with the selected response. Simulation begins when changing value from Disabled. To reset a simulated event, this parameter needs to be set back to Disabled first.

Number	Name	Description
0	Disabled	Event simulator is inactive
1	Lowest Response	The event selected with parameter No. 1402 is activated with its lowest event response. Note that if the event can be configured with a response parameter, the response parameter's setting will apply to the simulation.
10	Highest Response	The event selected with parameter No. 1402 is activated with its highest event response. Note that if the event can be configured with a response parameter, the response parameter's setting will apply to the simulation.

P3.2.3.3 Simulate Event Number No. 1402

Select an event to be simulated by its number. Refer to the **Error! Reference source not found.** section to check the number of each event.

7.4.3 Operational Counters (Menu Index 3.3)

This group shows readouts of converter's operational counters.

P3.3.1 Control Unit On Time No. 2000

Shows the total operating time for the control unit.

P3.3.2 Power Unit On Time No. 2001

Shows the total operating time for the power unit. The counter only increments if the DC link is powered.

P3.3.3 Energy Consumption No. 2002

Shows the energy consumed.

P3.3.5 Overvoltage Faults No. 2005

Shows the total number of overvoltage faults.

P3.3.6 Overcurrent Faults No. 2006

Shows the total number of overcurrent faults.

P3.3.7 Number of Starts No. 2008

Shows the number of starts of the converter.

P3.3.8 Active Running Hours **No. 2009**

Shows the total number of active running hours of the converter.

P3.3.9 Flash 0 Wear Counter **No. 2100**

Shows the erase count for most used flash 0 sector.

P3.3.10 Flash 1 Wear Counter **No. 2101**

Shows the erase count for most used flash 1 sector.

7.4.4 Backup & Restore (Menu Index 3.4)

This menu is used to access the backup and restore functions from the control panel.

7.4.4.1 Backup

This is a menu screen for creating parameter backups from the control panel. With MyDrive® Insight, similar options are available via the “Backup” button within the “Parameters” screen. Check the available settings via the control panel or MyDrive® Insight.

7.4.4.2 Restore

This is a menu for restoring parameter backups from the control panel. With MyDrive® Insight, similar options are available via the “Restore” button within the “Parameters” screen. Check the available settings via the control panel or MyDrive® Insight.

7.5 Customization (Menu Index 5)

7.5.1 Basic Settings (Menu Index 5.1)

P5.1.1 Date and Time **No. 2800**

Set the actual time and date. Format is YYYY-MM-DD and HH:MM:SS.

P5.1.2 Time Mode **No. 6232**

Select the time mode. Auto enables NTP.

Number	Name
0	Manual
1	Auto (NTP)

P5.1.3 NTP Server 1 **No. 6233**

Set the IPv4 address of the requested NTP server 1.

P5.1.4 NTP Server 2 **No. 6234**

Set the IPv4 address of the requested NTP server 2.

7.5.2 Control Panel (Menu Index 5.2)

The parameters in this group allow the selection of 1-5 signals for monitoring in the two control panel readout screens. These screens are visible in the panel’s home screen, which can be accessed by pressing the “Home”-button (the house icon). Readout Screen 1 will appear first. By navigating downwards with the arrow-buttons, Readout Screen 2 will appear.

7.5.2.1 Readout Screen 1 (Menu Index 5.2.1)

P5.2.1.1 Readout Field 1.1 **No. 300**

Select the parameter for readout field (screen 1 field 1).

Number	Name
0	None
9044	DC-link Voltage
9041	Grid Frequency
9040	Grid Voltage
2950	Heat Sink Temperature
2952	Control Unit Temperature
9053	Grid Power Factor
5115	DC-link Current
5117	DC-link Power
9060	Grid Current
9064	Grid Active Power
9051	Grid Reactive Power

P5.2.1.2 Readout Field 1.2 No. 301

Select the parameter for readout field (screen 1 field 2).

Same selection as Field 1.1 (No. 300).

P5.2.1.3 Readout Field 1.3 No. 302

Select the parameter for readout field (screen 1 field 3).

Same selection as Field 1.1 (No. 300).

P5.2.1.4 Readout Field 1.4 No. 303

Select the parameter for readout field (screen 1 field 4).

Same selection as Field 1.1 (No. 300).

P5.2.1.5 Readout Field 1.5 No. 304

Select the parameter for readout field (screen 1 field 5).

Same selection as Field 1.1 (No. 300).

7.5.2.2 Readout Screen 1 (Menu Index 5.2.2)

P5.2.2.1 Readout Field 2.1 No. 310

Select the parameter for readout field (screen 2 field 1).

Same selection as Field 1.1 (No. 300).

P5.2.2.2 Readout Field 2.2 No. 311

Select the parameter for readout field (screen 2 field 2).

Same selection as Field 1.1 (No. 300).

P5.2.2.3 Readout Field 2.3 No. 312

Select the parameter for readout field (screen 2 field 3).

Same selection as Field 1.1 (No. 300).

P5.2.2.4 Readout Field 2.4 No. 313

Select the parameter for readout field (screen 2 field 4).

Same selection as Field 1.1 (No. 300).

P5.2.2.5 Readout Field 2.5 No. 314

Select the parameter for readout field (screen 2 field 5).

Same selection as Field 1.1 (No. 300).

7.5.3 Custom Status Word (Menu Index 5.3)

The custom status word can be used to define a status word for the converter, which includes freely selectable bits from a set of other status words. The following status words can be used to for the Custom Status Word:

- DC/DC Operation Mode Selection Status Word, Application Status Word 1, Application Status Word 2, Limit Control Status Word

The custom status word can be monitored with parameter No. 2410.

The content for this word can be selected with individual parameters associated with each bit of the word. The content can be picked from other drive words. The value is given in the format of WBB, where W stands for the selection of the word and BB stands for the bit number within that word. Refer to the following table for the available content and their associated values.

DC/DC Control Mode Selection Status Word		Application Status Word 1	
100	DC Source Current/Power	200	Ready to Run
101	DC-link Current Control	201	Run
102	DC Source Voltage Control	202	Info
103	DC-link Voltage Control	203	Warning
104		204	Fault
105		205	PC (MyDrive Insight) Control Active
106		206	CP (Control Panel) Control Active
107		207	I/O Control Active
108		208	Fieldbus Control Active
109		209	
110		210	
111		211	Run Enable
112		212	Start Request
113		213	Quick Stop
Application Status Word 2		Limit Control Status Word	
300	Toggled Info	400	Pos. DC Source Current Limit Active
301	Toggled Warning	401	Neg. DC Source Current Limit
302	Toggled Fault	402	Max. DC Source Voltage Limit
303		403	Min. DC Source Voltage Limit
304		404	DC-link Overvoltage control
305		405	DC-link Undervoltage control
306		406	Pos. DC Source Power Limit
307		407	Neg. DC Source Power Limit
308		408	Pos. DC Source Current Limit Active
309		409	Neg. DC Source Current Limit
310	Pre Charge Ready	410	

DC/DC Control Mode Selection Status Word	Application Status Word 1
311	411
312 Ready to Switch On	412
313	413

P 5.3.1 Custom Status Word B0

Select the content of the respective bit of the custom status word. The content can be picked from the above table.

P 5.3.2 Custom Status Word B1

Select the content of the respective bit of the custom status word. The content can be picked from the above table.

P 5.3.3 Custom Status Word B2

Select the content of the respective bit of the custom status word. The content can be picked from the above table.

P 5.3.4 Custom Status Word B3

Select the content of the respective bit of the custom status word. The content can be picked from the above table.

P 5.3.5 Custom Status Word B4

Select the content of the respective bit of the custom status word. The content can be picked from the above table.

P 5.3.6 Custom Status Word B5

Select the content of the respective bit of the custom status word. The content can be picked from the above table.

P 5.3.7 Custom Status Word B6

Select the content of the respective bit of the custom status word. The content can be picked from the above table.

P 5.3.8 Custom Status Word B7

Select the content of the respective bit of the custom status word. The content can be picked from the above table.

P 5.3.9 Custom Status Word B8

Select the content of the respective bit of the custom status word. The content can be picked from the above table.

P 5.3.10 Custom Status Word B9

Select the content of the respective bit of the custom status word. The content can be picked from the above table.

P 5.3.11 Custom Status Word B10

Select the content of the respective bit of the custom status word. The content can be picked from the above table.

P 5.3.12 Custom Status Word B11

Select the content of the respective bit of the custom status word. The content can be picked from the above table.

P 5.3.13 Custom Status Word B12

Select the content of the respective bit of the custom status word. The content can be picked from the above table.

P 5.3.14 Custom Status Word B13

Select the content of the respective bit of the custom status word. The content can be picked from the above table.

P 5.3.15 Custom Status Word B14

Select the content of the respective bit of the custom status word. The content can be picked from the above table.

P 5.3.16 Custom Status Word B15

Select the content of the respective bit of the custom status word. The content can be picked from the above table.

7.6 Option Settings (Menu Index 9)

7.6.1 I/O And Relay Status (Menu Index 9.3)

P 9.3.1 Digital Input Bit Word

No. 1614

Shows the bitwise status of each digital input of this board.

Bit No.	Name	Description
0	Digital Input T13	TRUE = Over 15 V DC is applied between X13 T13 and Digital Input GND. FALSE = Less than 5 V DC is applied between X13 T13 and Digital Input GND.
1	Digital Input T14	TRUE = Over 15 V DC is applied between X13 T14 and Digital Input GND. FALSE = Less than 5 V DC is applied between X13 T14 and Digital Input GND.
2	Digital Input T15	TRUE = Over 15 V DC is applied between X13 T15 and Digital Input GND. FALSE = Less than 5 V DC is applied between X13 T15 and Digital Input GND.
3	Digital Input T16	TRUE = Over 15 V DC is applied between X13 T16 and Digital Input GND. FALSE = Less than 5 V DC is applied between X13 T16 and Digital Input GND.
4	Digital Input T17	TRUE = Over 15 V DC is applied between X13 T17 and Digital Input GND. FALSE = Less than 5 V DC is applied between X13 T17 and Digital Input GND.
5	Digital Input T18	TRUE = Over 15 V DC is applied between X13 T18 and Digital Input GND. FALSE = Less than 5 V DC is applied between X13 T18 and Digital Input GND.
6-11	Reserved	
12	Thermistor T71	TRUE = More than 4 k Ω is connected between X51 T71 and T72. FALSE = Less than 4 k Ω is connected between X51 T71 and T72.
13-15	Reserved	

P 9.3.2 Digital Output Bit Word

No. 1615

Shows the bitwise status of each digital output of this board.

Bit No.	Name	Description
0-1	Reserved	
2	Digital Output T21	TRUE = Connection between X13 T21 and I/O GND is active. FALSE = Connection between X13 T21 and I/O GND is active.
3	Digital Output T22	TRUE = Connection between X13 T22 and I/O GND is active. FALSE = Connection between X13 T22 and I/O GND is active.
4-11	Reserved	
12	Relay T02	TRUE = Connection between X101 T01 (COM) and T02 (NO) is active. FALSE = Connection between X101 T01 (COM) and T03 (NC) is active.
13	Relay T05	TRUE = Connection between X102 T04 (COM) and T05 (NO) is active. FALSE = Connection between X102 T04 (COM) and T06 (NC) is active.
14	Relay T08	TRUE = Connection between X103 T04 (COM) and T08 (NO) is active. FALSE = Connection between X103 T04 (COM) and T08 (NO) is inactive.

Bit No.	Name	Description
15	Reserved	

P 9.3.3 T31 Analog Output Value No. 1613

Shows the actual value of the terminal.

P 9.3.4 T33 Analog Input Value No. 1611

Shows the actual value of the terminal.

P 9.3.5 T34 Analog Input Value No. 1612

Shows the actual value of the terminal.

7.6.2 Digital Inputs/Outputs (Menu Index 9.4)

7.6.2.1 Input T13 (Menu Index 9.4.1)

P 9.4.1.1 T13 Terminal Mode No. 2015

Select the mode for the terminal.

The following are the selections for the parameter.

Number	Name	Description
0	Inactive	
3	Digital input	The terminal is configured as Boolean input (true/false).

P 9.4.1.2 T13 Signal Inversion No. 2291

Select whether the signal of the terminal is inverted.

The following are the selections for the parameter.

Number	Name	Description
0	Non-Inverted	The signal is not inverted.
1	Inverted	The signal is logically inverted.

P 9.4.1.3 T13 Standard Debounce Filtering Time No. 2024

Set the standard debounce filtering time for the terminal.

7.6.2.2 Input T14 (Menu Index 9.4.2)

P 9.4.2.1 T14 Terminal Mode No. 2016

Select the mode for the terminal. Selection is similar to T13 Terminal Mode.

P 9.4.2.2 T14 Signal Inversion No. 2292

Select whether the signal of the terminal is inverted. The selection is similar to T13 Signal Inversion.

P 9.4.2.3 T14 Standard Debounce Filtering Time No. 2029

Set the standard debounce filtering time for the terminal.

7.6.2.3 Input T15 (Menu Index 9.4.3)

P 9.4.3.1 T15 Terminal Mode No. 2022

Select the mode for the terminal. Selection is similar to T13 Terminal Mode.

P 9.4.3.2 T15 Signal Inversion No. 2295

Select whether the signal of the terminal is inverted. The selection is similar to T13 Signal Inversion.

P 9.4.3.3 T15 Standard Debounce Filtering Time No. 2297

Set the standard debounce filtering time for the terminal.

7.6.2.4 Input T16 (Menu Index 9.4.4)

P 9.4.4.1 T16 Terminal Mode No. 2298

Select the mode for the terminal. Selection is similar to T13 Terminal Mode.

P 9.4.4.2 T16 Signal Inversion No. 2296

Select whether the signal of the terminal is inverted. The selection is similar to T13 Signal Inversion.

P 9.4.4.3 T16 Standard Debounce Filtering Time No. 2060

Set the standard debounce filtering time for the terminal.

7.6.2.5 Input T17 (Menu Index 9.4.5)

P 9.4.5.1 T17 Terminal Mode No. 2217

Select the mode for the terminal. Selection is similar to T13 Terminal Mode.

P 9.4.5.2 T17 Signal Inversion No. 2293

Select whether the signal of the terminal is inverted. The selection is similar to T13 Signal Inversion.

P 9.4.5.3 T17 Standard Debounce Filtering Time No. 2034

Set the standard debounce filtering time for the terminal.

7.6.2.6 Input T18 (Menu Index 9.4.6)

P 9.4.6.1 T18 Terminal Mode No. 2018

Select the mode for the terminal. Selection is similar to T13 Terminal Mode.

P 9.4.6.2 T18 Signal Inversion No. 2294

Select whether the signal of the terminal is inverted. The selection is similar to T13 Signal Inversion.

P 9.4.6.3 T18 Standard Debounce Filtering Time No. 2039

Set the standard debounce filtering time for the terminal.

7.6.2.7 Output T21 (Menu Index 9.4.7)

P9.4.7.1 T21 Terminal Mode No. 4015

Select the mode for the terminal.

Number	Name
0	Inactive
1	Digital Output

P9.4.7.2 T21 Digital Output Type **No. 4013**

Select the operating logic for the digital output.

The following are the selections for the parameter.

Number	Name	Description
0	Tri state	Disable output (high impedance).
1	Open collector sink (NPN)	Open collector sink (NPN).
2	Open collector source (PNP)	Open collector source (PNP).
3	Push pull	Terminal can both sink and source.

7.6.2.8 Output T22 (Menu Index 9.4.8)
P 9.4.8.1 T22 Terminal Mode **No. 4016**

Select the mode for the terminal.

Number	Name
0	Inactive
1	Digital Output

P 9.4.8.2 T22 Digital Output Type

Select the operating logic for the digital output.

The following are the selections for the parameter.

Number	Name	Description
0	Tri state	Disable output (high impedance).
1	Open collector sink (NPN)	Open collector sink (NPN).
2	Open collector source (PNP)	Open collector source (PNP).
3	Push pull	Terminal can both sink and source.

7.6.3 Analog Inputs/Outputs (Menu Index 9.5)
P9.5.1.1 T31 Terminal Mode **No. 2019**

Select the mode for the terminal.

Number	Name
0	Inactive
5	Analog Output

P9.5.1.2 T31 Terminal Type **No. 2284**

Select the type of terminal. If voltage is selected, the unit is V. If current is selected, the unit is mA.

Number	Name
0	Off
1	Voltage

Number	Name
2	Current

P9.5.1.3 T31 Minimum Value No. 2283

Set the voltage or current representing 0% of the signal.

P9.5.1.4 T31 Maximum Value No. 2282

Set the voltage or current representing 100% of the signal.

7.6.3.1 Input T33

P9.5.2.1 T33 Terminal Mode No. 2020

Select the mode for the terminal.

Number	Name
0	Inactive
6	Analog Input

P9.5.2.2 T33 Terminal Type No. 2273

Select the type of terminal. If voltage is selected, the unit is V. If current is selected, the unit is mA.

Number	Name
1	Voltage
2	Current

P9.5.2.3 T33 Minimum Value No. 2272

Set the voltage or current representing 0% of the signal.

P9.5.2.4 T33 Maximum Value No. 2271

Set the voltage or current representing 100% of the signal.

P9.5.2.5 T33 Filter Time No. 2270

Set the filter time for the terminal.

P9.5.2.6 T33 Live Zero Threshold Value No. 2274

Set the live zero threshold value for the terminal. The response to a live zero event is defined with parameter No. 4555 "Live Zero Response".

P9.5.2.7 T33 Live Zero Timeout Value No. 2275

Set the live zero timeout value for the terminal. The response to a live zero event is defined with parameter No. 4555 "Live Zero Response".

7.6.3.2 Input T34

P9.5.3.1 T34 Terminal Mode No. 2021

Select the mode for the terminal.

Number	Name
0	Inactive
6	Analog Input

P9.5.3.2 T34 Terminal Type No. 2279

Select the type of terminal. If voltage is selected, the unit is V. If current is selected, the unit is mA.

Number	Name
1	Voltage
2	Current

P9.5.3.3 T34 Minimum Value No. 2278

Set the voltage or current representing 0% of the signal.

P9.5.3.4 T34 Maximum Value No. 2277

Set the voltage or current representing 100% of the signal.

P9.5.3.5 T34 Filter Time No. 2276

Set the filter time for the terminal.

P9.5.3.6 T34 Live Zero Threshold Value No. 2280

Set the live zero threshold value for the terminal. The response to a live zero event is defined with parameter No. 4555 "Live Zero Response".

P9.5.3.7 T34 Live Zero Timeout Value No. 2281

Set the live zero timeout value for the terminal. The response to a live zero event is defined with parameter No. 4555 "Live Zero Response".

7.6.4 Temperature Measurement

This group and its subgroups appear only if a Temperature Measurement OC7T0 option is included in the converter. This menu appears as many times as there are these options in the system. Each menu and its parameters have the suffix of their option slot.

7.6.4.1 Temperature Measurement Status

P9.3.2 T4 Temperature Value No. 4040

Shows the measured temperature of the terminal.

P9.3.3 T8 Temperature Value No. 4041

Shows the measured temperature of the terminal.

P9.3.4 T12 Temperature Value No. 4042

Shows the measured temperature of the terminal.

P9.3.5 T16 Temperature Value No. 4043

Shows the measured temperature of the terminal.

P9.3.6 T20 Temperature Value No. 4044

Shows the measured temperature of the terminal.

7.6.4.2 Temperature inputs

7.6.4.2.1 Input T4

P9.4.1.1 T4 Terminal Mode No. 4045

Select the mode for the terminal.

Number	Name
0	Inactive
7	Temperature input

P9.4.1.2 T4 Connection Type No. 4046

Select the connection type for the sensor.

Number	Name
0	No sensor
2	2-wire
3	3-wire
4	4-wire

P9.4.1.3 T4 Temperature Sensor Type No. 4047

Select which type of temperature sensor is connected to the terminal.

Number	Name
0	No sensor
1	Pt100
2	2xPt100
3	3xPt100
4	Pt1000
5	Ni1000Tk5000
6	Ni1000Tk6180
7	KTY84-1x0
8	KTY84-151
9	KTY84-152
10	KTY81/82-1x0
11	KTY81/82-121
12	KTY81/82-122
13	KTY81/82-151
14	KTY81/82-152
15	KTY81/82-2x0
16	KTY81/82-221
17	KTY81/82-222
18	KTY81/82-251
19	KTY81/82-252

P9.4.1.4 T4 Offset No. 4048

Set the offset of the temperature measured.

7.6.4.2.2 Input T8

P9.4.2.1 T8 Terminal Mode No. 4049

Select the mode for the terminal.

Number	Name
0	Inactive
7	Temperature input

P9.4.2.2 T8 Connection Type No. 4050

Select the connection type for the sensor.

Number	Name
0	No sensor
2	2-wire
3	3-wire
4	4-wire

P9.4.2.3 T8 Temperature Sensor Type No. 4051

Select which type of temperature sensor is connected to the terminal.

Number	Name
0	No sensor
1	Pt100
2	2xPt100
3	3xPt100
4	Pt1000
5	Ni1000Tk5000
6	Ni1000Tk6180
7	KTY84-1x0
8	KTY84-151
9	KTY84-152
10	KTY81/82-1x0
11	KTY81/82-121
12	KTY81/82-122
13	KTY81/82-151
14	KTY81/82-152
15	KTY81/82-2x0
16	KTY81/82-221
17	KTY81/82-222
18	KTY81/82-251
19	KTY81/82-252

P9.4.2.4 T8 Offset **No. 4052**

Set the offset of the temperature measured.

7.6.4.2.3 Input T12
P9.4.3.1 T12 Terminal Mode **No. 4053**

Select the mode for the terminal.

Number	Name
0	Inactive
7	Temperature input

P9.4.3.2 T12 Connection Type **No. 4054**

Select the connection type for the sensor.

Number	Name
0	No sensor
2	2-wire
3	3-wire
4	4-wire

P9.4.3.3 T12 Temperature Sensor Type **No. 4055**

Select which type of temperature sensor is connected to the terminal.

Number	Name
0	No sensor
1	Pt100
2	2xPt100
3	3xPt100
4	Pt1000
5	Ni1000Tk5000
6	Ni1000Tk6180
7	KTY84-1x0
8	KTY84-151
9	KTY84-152
10	KTY81/82-1x0
11	KTY81/82-121
12	KTY81/82-122
13	KTY81/82-151
14	KTY81/82-152
15	KTY81/82-2x0
16	KTY81/82-221

Number	Name
17	KTY81/82-222
18	KTY81/82-251
19	KTY81/82-252

P9.4.3.4 T12 Offset **No. 4056**

Set the offset of the temperature measured.

7.6.4.2.4 Input T16

P9.4.4.1 T16 Terminal Mode **No. 2298**

Select the mode for the terminal.

Number	Name
0	Inactive
7	Temperature input

P9.4.4.2 T16 Connection Type **No. 4058**

Select the connection type for the sensor.

Number	Name
0	No sensor
2	2-wire
3	3-wire
4	4-wire

P9.4.4.3 T16 Temperature Sensor Type **No. 4059**

Select which type of temperature sensor is connected to the terminal.

Number	Name
0	No sensor
1	Pt100
2	2xPt100
3	3xPt100
4	Pt1000
5	Ni1000Tk5000
6	Ni1000Tk6180
7	KTY84-1x0
8	KTY84-151
9	KTY84-152
10	KTY81/82-1x0
11	KTY81/82-121
12	KTY81/82-122

Number	Name
13	KTY81/82-151
14	KTY81/82-152
15	KTY81/82-2x0
16	KTY81/82-221
17	KTY81/82-222
18	KTY81/82-251
19	KTY81/82-252

P9.4.4.4 T16 Offset **No. 4060**

Set the offset of the temperature measured.

7.6.4.2.5 Input T20

P9.4.5.1 T20 Terminal Mode **No. 4017**

Select the mode for the terminal.

No.	Name
0	Inactive
7	Temperature input

P9.4.5.2 T20 Connection Type **No. 4062**

Select the connection type for the sensor.

Number	Name
0	No sensor
2	2-wire
3	3-wire
4	4-wire

P9.4.5.3 T20 Temperature Sensor Type **No. 4063**

Select which type of temperature sensor is connected to the terminal.

Number	Name
0	No sensor
1	Pt100
2	2xPt100
3	3xPt100
4	Pt1000
5	Ni1000Tk5000
6	Ni1000Tk6180
7	KTY84-1x0
8	KTY84-151

Number	Name
9	KTY84-152
10	KTY81/82-1x0
11	KTY81/82-121
12	KTY81/82-122
13	KTY81/82-151
14	KTY81/82-152
15	KTY81/82-2x0
16	KTY81/82-221
17	KTY81/82-222
18	KTY81/82-251
19	KTY81/82-252

P9.4.5.4 T20 Offset **No. 4064**

Set the offset of the temperature measured.

7.7 Connectivity

This section provides information about configuring and monitoring all types of communication interfaces as well as the communication and fieldbus protocols available. Following are the available interfaces:

- Communication interface X0 (service port).
- Communication interface X1/X2 (fieldbus ports).
- Attached communication options.

Note that the availability of different fieldbus protocols depends on the product.

7.7.1 Integrated Communication

7.7.1.1 Communication interfaces

7.7.1.1.1 Host Settings

P10.1.1.1.1 Fully Qualified Domain Name **No. 7036**

Fully Qualified Domain Name. Consists of a host name label and at least 1 higher-level domain separated by the symbol "." with up to 240 characters in total. Each label contains up to 63 characters and starts with a lowercase letter and ends with alphanumeric lowercase character and have as interior characters only alphanumeric lowercase characters and '-'.

7.7.1.1.2 Ethernet Interface X0

7.7.1.1.2.1 IPv4 Settings

This is a menu screen for enabling IP configuration of the X0 interface. Check the available settings via the control panel or MyDrive® Insight.

7.7.1.1.2.2 IPv4 Status

This is a menu screen containing information about the IP configuration of the X0 interface. Check the available information via the control panel or MyDrive® Insight.

7.7.1.1.3 Ethernet Interface X1/X2 Settings

7.7.1.1.3.1 IPv4 Settings

This is a menu screen for enabling IP configuration of the X1/2 interface. Check the available settings via the control panel or MyDrive® Insight.

7.7.1.1.3.2 IPv4 Status

This is a menu screen containing information about the IP configuration of the X1/X2 interface. Check the available information via the control panel or MyDrive® Insight.

7.7.1.1.4 Ethernet port X0

7.7.1.1.4.1 X0 Settings

P10.1.1.4.1.1 Link configuration X0 No. 7047

Select the configuration of the Ethernet link parameters.

Number	Name
0	Auto negotiation
1	10 Mbps full duplex
2	10 Mbps half duplex
3	100 Mbps full duplex
4	100 Mbps half duplex

7.7.1.1.5 Ethernet port X1

7.7.1.1.5.1 X1 Settings

P10.1.1.5.1.1 Link Configuration X1 No. 7048

Select the configuration of the Ethernet link parameters.

Number	Name
0	Auto negotiation
1	10 Mbps full duplex
2	10 Mbps half duplex
3	100 Mbps full duplex
4	100 Mbps half duplex

7.7.1.1.6 Ethernet port X2

7.7.1.1.6.1 X2 Settings

P10.1.1.6.1.1 Link Configuration X2 No. 7049

Select the configuration of the Ethernet link parameters.

Number	Name
0	Auto negotiation
1	10 Mbps full duplex
2	10 Mbps half duplex
3	100 Mbps full duplex
4	100 Mbps half duplex

7.7.1.1.7 Port Mirroring

This is a menu screen for enabling and disabling the port-mirroring function for network troubleshooting with a network analyzer tool. Check the available configurations via the control panel or MyDrive® Insight.

7.7.1.2 Protocols

7.7.1.2.1 PROFINET®

7.7.1.2.1.1 Status

7.7.1.2.1.1.1 PROFINET® Report

This is the PROFINET® report screen showing active PROFINET® connection and configuration information. Check the available information via the control panel or MyDrive® Insight.

7.7.1.2.1.2 Configuration

P10.1.2.1.2.1 Name of Station **No. 7080**

Set the name of the station. The PROFINET® device is identified by its name of station. Each name must be unique in the network.

7.7.1.2.1.3 Diagnosis

P10.1.2.1.3.1 Diagnostic Fault **No. 7081**

Enables diagnostic faults. When disabled the device will not send any PROFINET® diagnosis message with severity "Fault" when a fault is present on device.

Number	Name	Description
0	Disabled	Fault diagnosis messages are not sent.
1	Enabled	Fault diagnosis messages are sent.

P10.1.2.1.3.2 Diagnostic Warning **No. 7083**

Enables diagnostic warning. When disabled the device will not send any PROFINET® diagnosis message with severity "Maintenance required" when a warning is present on device.

Number	Name	Description
0	Disabled	Warning diagnosis messages are not sent.
1	Enabled	Warning diagnosis messages are sent.

7.7.1.2.2 Modbus® TCP

7.7.1.2.2.1 Configuration

P10.1.2.2.1.1 Persistent Storage **No. 7061**

Select if persistent storage is active for Modbus® writes.

Number	Name	Description
0	Disabled	When writing to configuration parameters via a Modbus® protocol, the latest written value is not stored to memory. If the converter is rebooted the latest written value is lost.
1	Enabled	When writing to configuration parameters via a Modbus® protocol, the latest written value is stored to memory. If the converter is rebooted the latest written value is retained.

P10.1.2.2.1.2 Byte Order No. 7062

Select the byte order.

Byte Order refers to how data is stored in memory. In Modbus communication, this determines the sequence in which bytes are sent or received. Using this parameter select the byte order as described below,

Number	Name	Description
0	Big Endian	The most significant byte (MSB) is stored or transmitted first, thus decreasing byte order. Suppose the system has an 8-bit register, for holding the value 0xAB starting at address 1000. Then at location1000: 0xA (MSB) will be stored and at location1001: 0xB (LSB) will be stored.
1	Little Endian	The least significant byte (LSB) is stored or transmitted first, thus increasing byte order. Suppose the system has an 8-bit register, for holding the value 0xAB starting at address 1000. Then at location1000: 0xB (LSB) will be stored and at location1001: 0xA (MSB) will be stored.

P10.1.2.2.1.3 Word Order No. 7063

Select the word order.

Number	Name	Description
0	Big Endian	The most significant byte (MSB) is stored or transmitted first, thus decreasing byte order. Suppose the system has an 8-bit register, for holding the value 0xABCD starting at address 1000. Then at location1000: 0xAB (MSB) will be stored and at location1001: 0xCD (LSB) will be stored.
1	Little Endian	The least significant byte (LSB) is stored or transmitted first, thus increasing byte order. Suppose the system has an 8-bit register, for holding the value 0xABCD starting at address 1000. Then at location1000: 0xCD (LSB) will be stored and at location1001: 0xAB (MSB) will be stored.

8 MyDrive® Insight

8.1 Introduction to MyDrive® Insight

MyDrive® Insight is a platform-independent software tool that supports the commissioning, engineering, and monitoring of the iC7 series. Some of the key features include:

- Fast and easy configuration and commissioning
- Monitoring the converters as part of daily operations
- Collecting data and information for troubleshooting, maintenance, and service
- Discovering and accessing multiple converters in a network
- Intuitive user interface with notifications and visualizations on real time converter information and events
- PC control to perform operations such as starting or stopping the converter, set references, set direction, reset, and coast of the converter.
- Performing updates on single or multiple converters
- Backing up and restoring parameter settings
- Data logging and analyzing for troubleshooting.

NOTICE

The section is documented for MyDrive® Insight version 2.11.2 or above. To utilize the latest MyDrive® Insight functions, make sure to uninstall lower versions of MyDrive® Insight from the workstation.

NOTICE

The section MyDrive® Insight in the application guide covers basic information such as getting started with MyDrive® Insight, accessing and viewing or changing the parameters, and PC control to operate the drive using MyDrive® Insight. For further information on the different MyDrive screens, integrated help within MyDrive® Insight will be available in future releases.

8.2 Getting Started with MyDrive Insight

As a prerequisite, ensure that MyDrive® Insight is installed on the device (PC or laptop). MyDrive® Insight can be downloaded and installed from MyDrive® Suite, available here: <https://suite.mydrive.danfoss.com/>

- To establish a point-to-point connection between the converter and the device, use the communication interface X0 and the RJ45 Ethernet port on the device by using a standard Ethernet cable. If the device does not have an RJ45 Ethernet port or it is already in use, then a conventional adapter from USB-C to RJ45 can be used. To connect several converters at the same time, use an Ethernet switch between the PC and the control units.

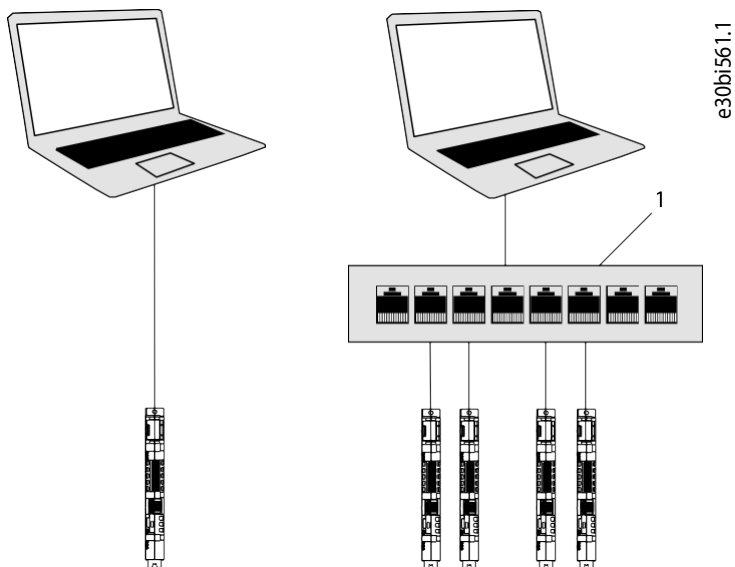

Illustration 25: Connection to the PC

1 Ethernet switch

- When the converter is powered up and in Ready state, open MyDrive® Insight on the device and the converter is recognized.
- To establish or confirm the connection, click the arrow button.

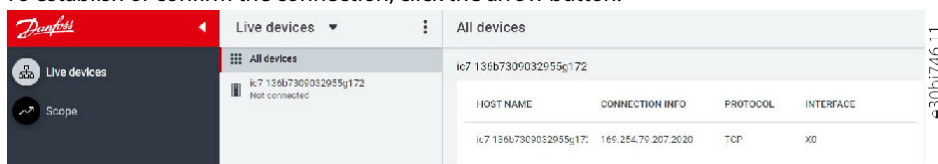

Illustration 26: Confirm Connection

Once the connection is established, the converter is marked with a green connection symbol in MyDrive®

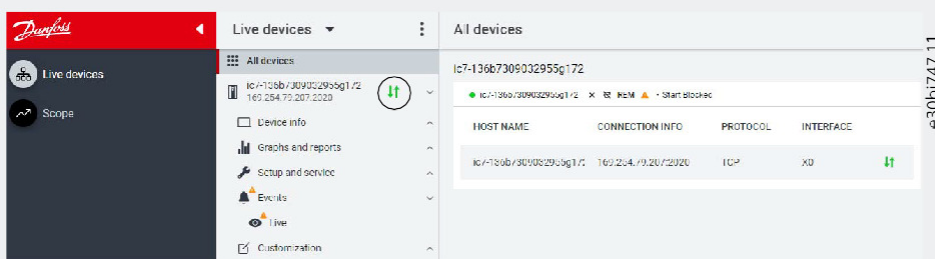

Illustration 27: Connection Established

- To interact with the converter, navigate to the required screen in MyDrive® Insight. The example picture shows the *Device Info* screen.

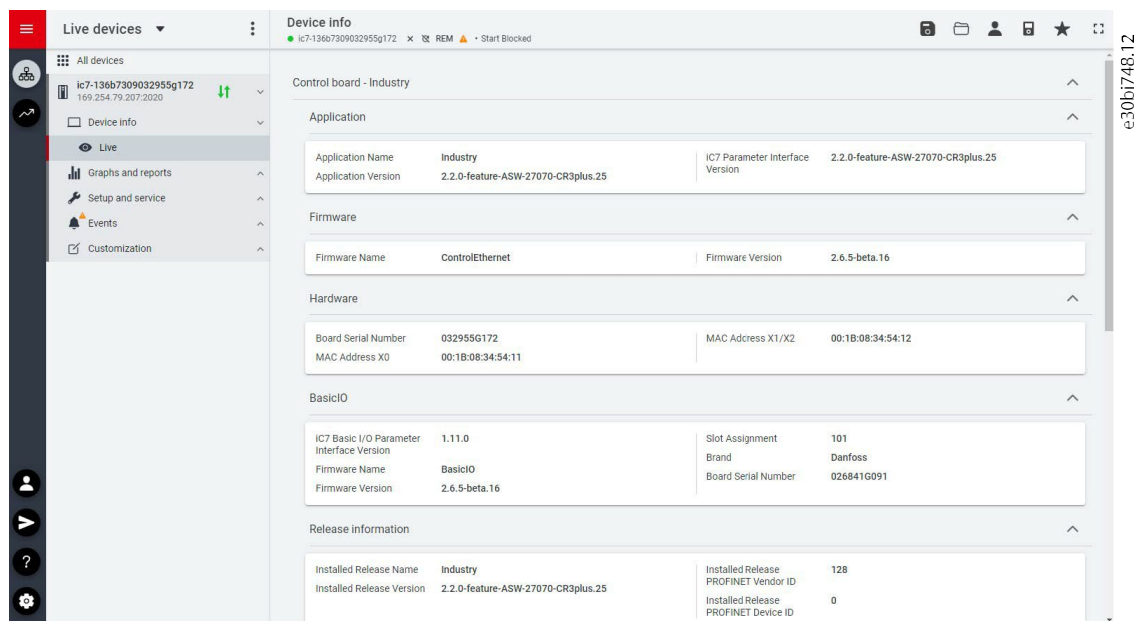

Illustration 28: Device Info

8.3 Datalogger

The Datalogger feature in MyDrive® Insight allows the monitoring and recording of various signals and related data for selected drives. Follow the steps below to access and use the Datalogger:

Step 1: Select the Drive

- **Navigate to the MyDrive® Insight interface.**
- In the main dashboard, locate and **select the specific drive** to monitor. This is typically done by clicking on the drive's name or icon.

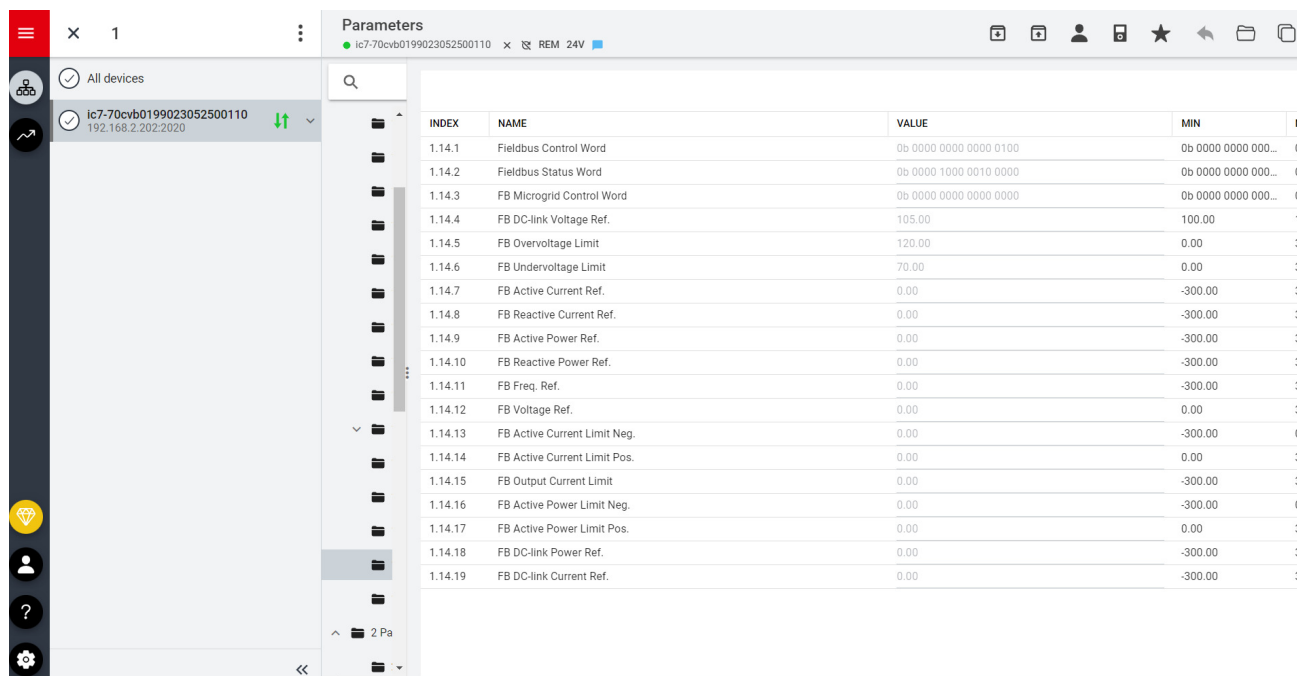

Step 2: Access the Graphs and Reports Section

- Once the drive is selected, **navigate to the left-hand menu** or the top menu bar (depending on the interface layout).
- Click on **Logs and Reports**. This section contains various tools for visualizing and analyzing drive data.

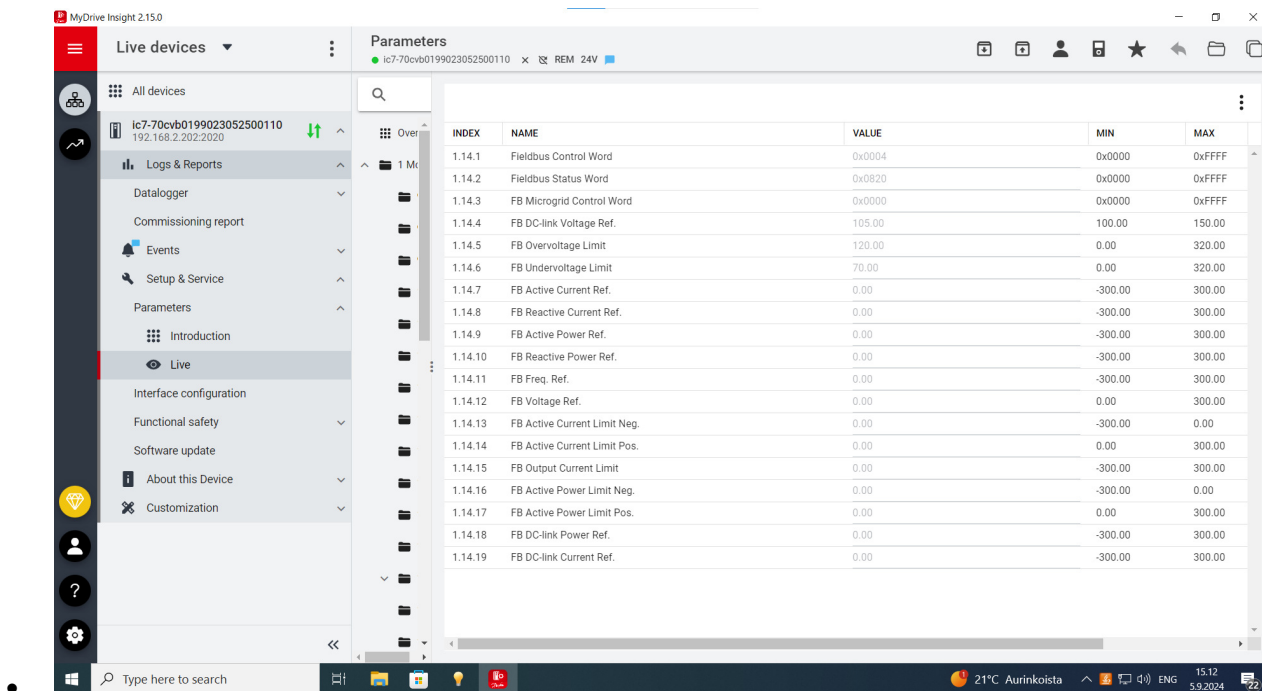

Step 3: Open the Datalogger

- In the Graphs and Reports section, locate and click on **Datalogger**.
- The Datalogger interface will open, displaying available signals and options for data logging.

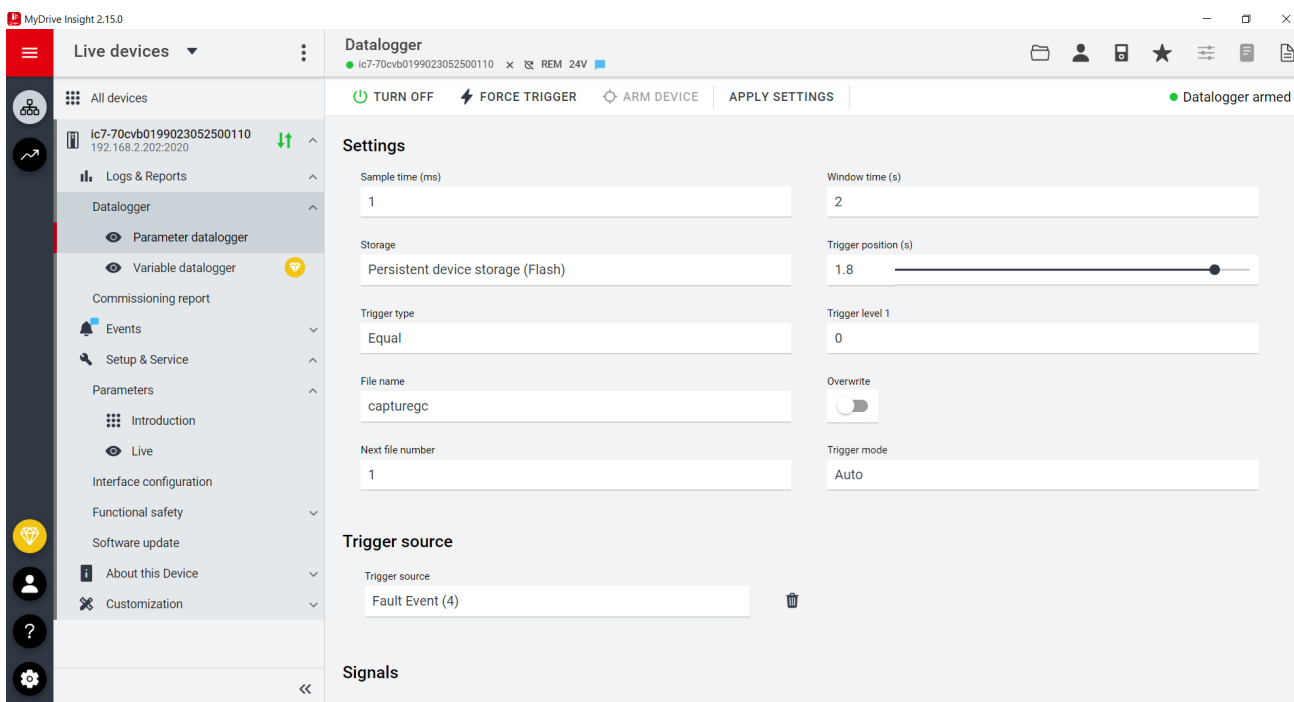

Step 4: Select Signals for Monitoring

- In the Datalogger interface, **select the signals** to monitor. These could include parameters like Grid Frequency, Active Current Ref %, Converter Output voltage and others, depending on what is available for the drive.
- Multiple signals can be selected for simultaneous monitoring.

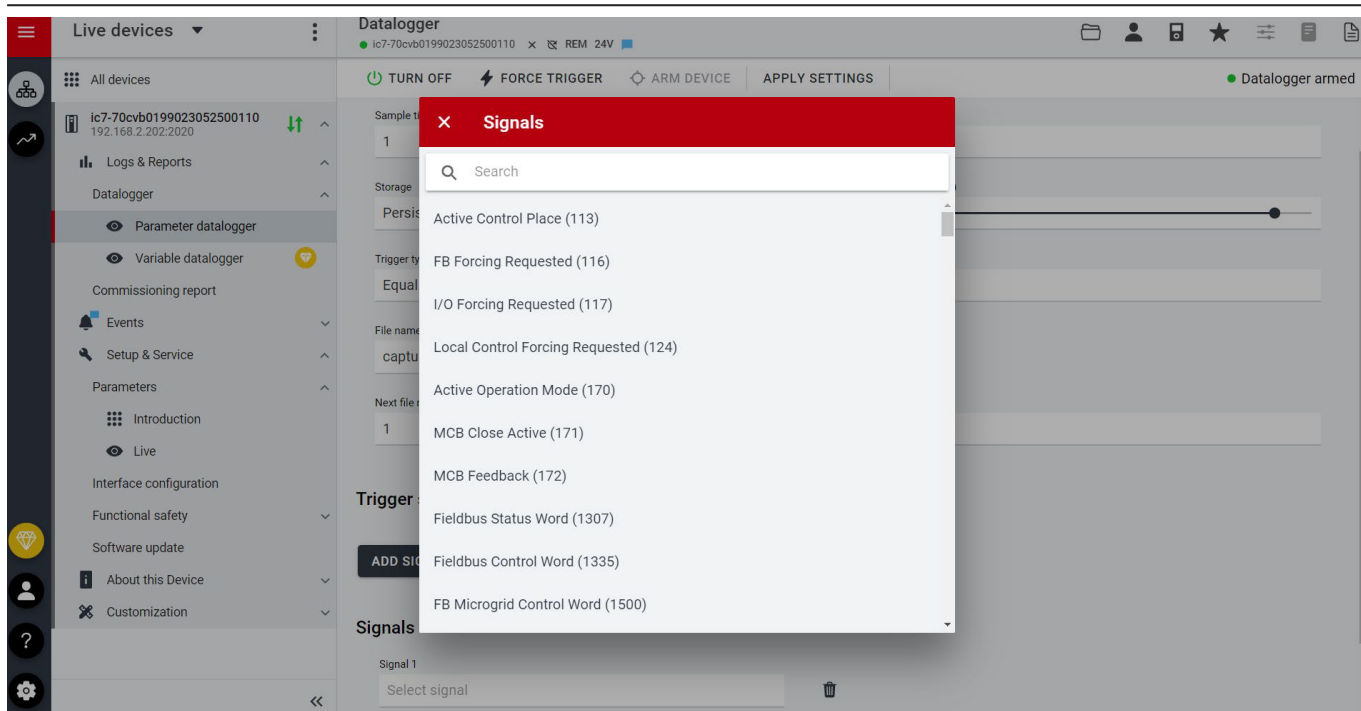

Step 5: Configure Logging Parameters

- Set the desired **storage location, sample time** and **duration**. This determines how frequently data is recorded and for how long.
- There may also be options to set triggers or conditions for logging, such as starting the log when a certain event occurs.

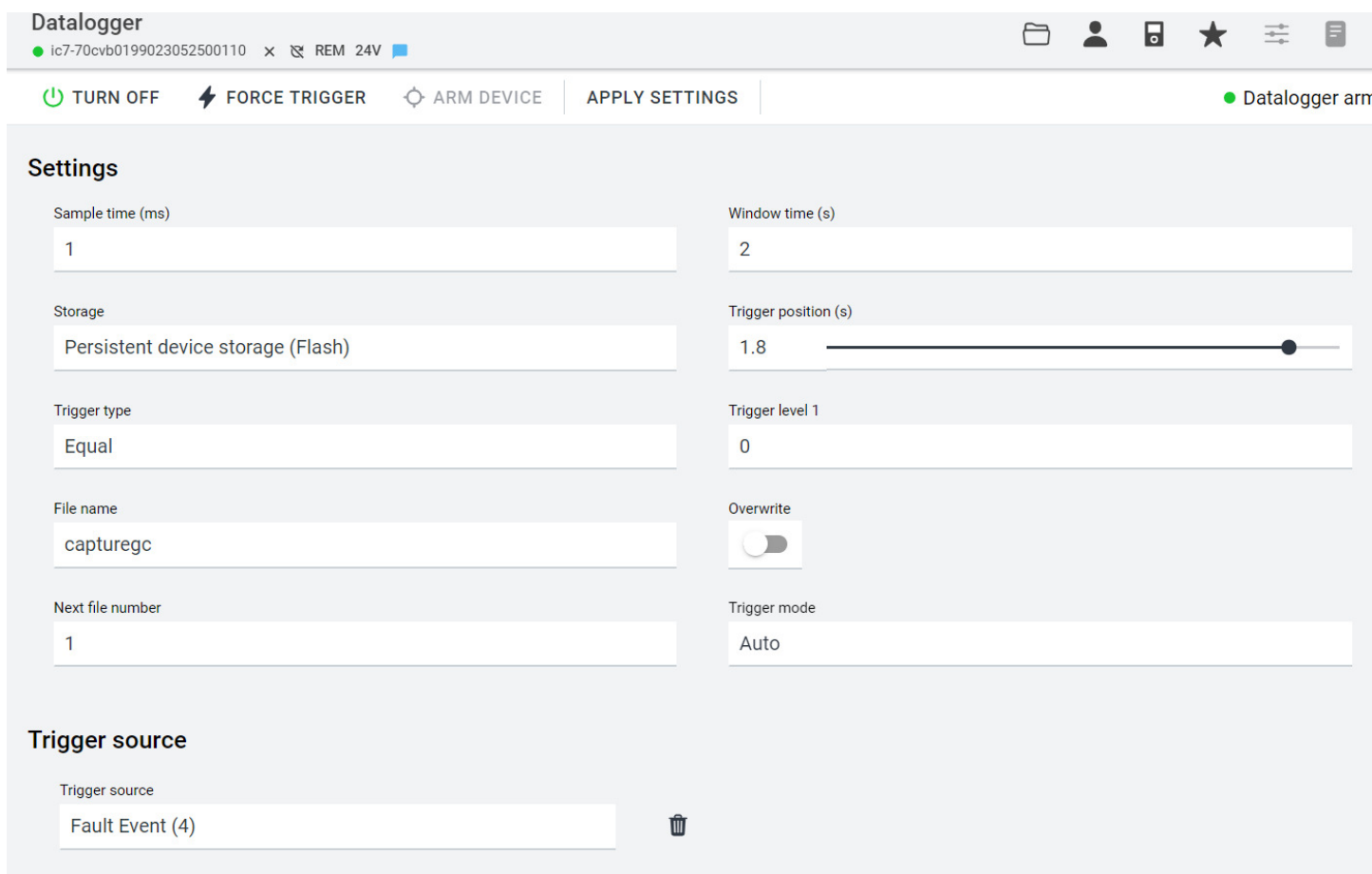

Step 6: Start Logging

- Once the signals and parameters are configured, click **Apply Setting and Arm Device** to begin the process.

- The system will now record the selected signals according to the settings.

Step 7: View and Analyze Data

- As data is logged, it is displayed in right side bar or chart within the Datalogger interface as shown below, if window is not visible then click on Page icon as highlighted besides "Captures" heading.
- It is possible to pause, zoom in, or export the data for further analysis or reporting.

Step 8: Save or Export Data

- After the logging session is complete, the data can be saved directly within MyDrive® Insight for future reference.
- Alternatively, the logged data can be exported to a chosen file format (CSV or Excel, for example) for external analysis or record-keeping.

NOTICE

The application guide covers basic information such as accessing parameters and using MyDrive® Insight as the PC control place.

9 Troubleshooting

9.1 Viewing Warnings

When a warning event occurs, the status indicators (halo and WARN) turn yellow. The converter remains operational and when the trigger for the warning is corrected, the indicators turn white.

To view the details of a warning, go to parameter group **6.4.1 Active Events**.

To view the history of events for the drive, go to parameter group **6.4.2 Event History**.



Illustration 31: Warnings

9.2 Viewing and Resetting Faults

When a fault occurs in the converter, the status indicators halo and FAULT turn red. The control panel display shows the name of the fault, and allows a direct reset.

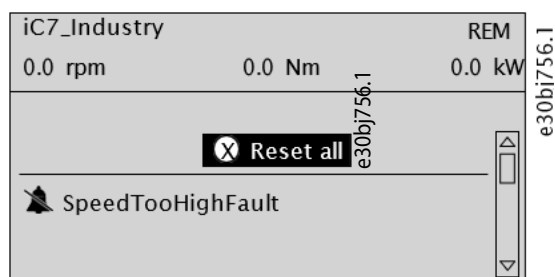

Illustration 32: Fault on the Control Panel

1. To view details about a fault and its cause, select the fault in the list shown on the control panel and press **[OK]**.

If the control panel display has changed, simultaneously press the left and right arrows on the control panel to return to parameter group **6.4.1 Active Events**.

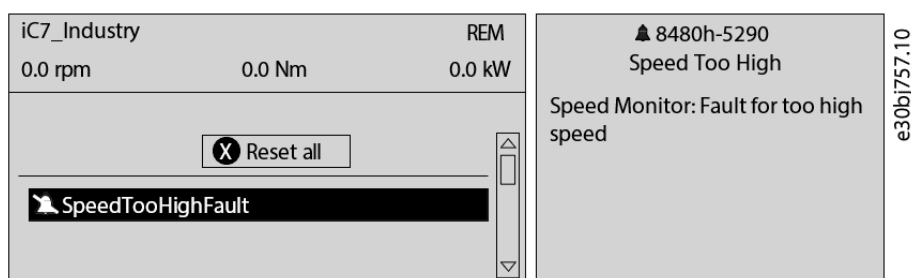

Illustration 33: View Active Faults

2. Resolve all triggers causing the fault.
3. Select *Reset all* and press **[OK]**.

9.3 Reading the Event Summary Table

9.3.1 Group number and number (columns 1–2)

Events in iC7 series products have 2 different identifiers: Group numbers and Individual numbers.

The group numbers for iC7 series follow the DRIVECOM industry standard error code specification. The specification originated with the Interbus communication profile. The [Interbus V3.0 base profile](#) was released on 2018-04-19. The [inverter specific profile](#) was released on 1997-12-15. The error code specification was adopted by CAN in Automation and ODVA and is used within their respective Drive Profile. The list of standardized error codes can be found within [IEC 61800-7-201](#).

Unlike individual numbers, the group numbers are not unique since multiple errors can be related to each other. An example is different ground faults which share the Group Number 0x2330.

9.3.2 Display name and description (columns 3–4)

The columns are showing the name and a brief description of the event. A few display names are marked with a * which indicates that the event can be controlled via a parameter.

9.3.3 Type of event (columns 5–8)

The event summary table shows column names where I – Info, W – Warning, F – Fault, and PF – Protected Fault.

- **Info:** The notification provides information of the operation of the converter.
- **Warning:** The notification informs that an undesired event is happening. The converter can continue operation, but it might be with reduced performance and/or the converter might trip soon.
- **Fault (Trip):** An error notification informs that an undesired high-severity event occurred. Modulation stops immediately. The error message and the error can be reset without power cycling the converter.
- **Protected Fault (Trip Lock):** An error notification informs that an undesired high-severity event happened. Modulation stops immediately. The error message and the error can be reset after power cycling the converter.

9.3.4 Action of the converter (column 9)

The columns show the possible action of the converter:

- **RC:** Converter ramps current to 0 before stopping modulation.
- **C:** Converter stops modulation immediately.

9.4 Events Summary for DC/DC Converter Application Software

The following table lists the events that can occur in the DC/DC Converter application software.

Table 38: Summary Table

Group Number (Hex)	Number (Decimal)	Display Name	Description	Type of Event				Converter Action
				I	W	F	P F	
0x20FF	4372	Current Injection Limit	The time limit for the short-term current injection has been exceeded.		X	X		C
0x2110	4379	CM Current High	An excessive common mode current has been detected in the LCL-filter.		X	X		C
0x2181	5152	DcSourceCurrentHighPositiveDirection	DC source current above current limit or positive current limit.		X			
0x2181	5153	DcSourceCurrentHighNegativeDirection	DC source current below current limit (negated) or negative current limit.		X			
0x2212	4374	DC-link Resonance	A resonance on the DC link with excessive RMS current values has been detected.		X	X		C
0x2221	4384	Thermal Overload Rectifier	The rectifier is thermally overloaded. Mission profile is too demanding.		X	X		C
0x2222	4373	DC-link Overcurrent	An overcurrent on the main DC-link capacitors has been detected.		X	X		C
0x2311	4097	Inverter Overload	Thermal overload is detected in the inverter of the drive. Reduce the output load.		X	X		C
0x2311	4368	Output Current High 0	The output current of the drive has exceeded its normal range at low speed. Shock load or too fast acceleration with high-inertia loads can cause this fault. Check that the motor size matches the drive and the motor data. is correct. Check that the motor shaft can be turned.		X	X		C
0x2311	4369	Output Current High 1	The output current of the drive has exceeded its normal range. Shock load or too fast acceleration with high-inertia loads can cause this fault. Check that the motor size matches the drive, and the motor data is correct. Check that the motor shaft can be turned.		X	X		C
0x2311	4375	Excessive Current Limiting	The output current of the drive has exceeded the current limit multiple times. Check that the motor size matches the drive and the motor data is correct. Check that the motor shaft can be turned.		X	X		C

Table 38: Summary Table (continued)

Group Number (Hex)	Number (Decimal)	Display Name	Description	Type of Event				Converter action
				I	W	F	P F	
0x2311	4377	Smart Derating Fault	A Smart Derating fault is detected. The load is too demanding for the current derating level. Lower the switching frequency if possible.		X	X		C
0x2311	4380	Current Limit Setting Fault	The actual current limit setting is too high relative to the selected constant control frequency level. Reduce the control frequency setting or reduce the current limit setting.			X		C
0x2330	4352	Ground Fault 0	A high-impedance ground fault is detected on the output. Check the insulation of motor cable and motor.		X	X		C
0x2330	4353	Ground Fault 1	A high-impedance ground fault is detected on the output. Check the insulation of motor cable and motor.		X	X		C
0x2330	4354	Ground Fault 2	A low-impedance ground fault is detected on the output. Check the insulation of motor cable and motor.		X		X	C
0x2330	4355	Ground Fault 21	A high or low-impedance ground fault is detected on the output. Check the insulation of motor cable and motor.		X		X	C
0x2340	4356	Inverter Short Circuit	A short circuit at the inverter output is detected. Check the motor and motor cable.		X		X	C
0x2340	4370	Output Current High 2	A critical output overcurrent has been detected. Check for short circuits on the output.		X		X	C
0x2340	4649	Desat Gate Driver	The gate driver has detected desaturation condition.			X		C
0x23FE	4371	Current Imbalance	A current imbalance between paralleled power units has been detected.		X			
0x23FF	4175	Motor Disconnected	The motor is disconnected.		X	X		C
0x23FF	4176	Missing Motor Phase	A missing motor phase is detected. Check motor, motor cables, and connections.		X	X		C
0x3110	4162	Grid Voltage Spikes	Excessive spikes on the grid voltage have been detected.		X	X		C
0x3110	4164	Grid Voltage High	Grid voltage (RMS) above the normal operating range is detected.		X	X		C

Table 38: Summary Table (continued)

Group Number (Hex)	Number (Decimal)	Display Name	Description	Type of Event				Converter action
				I	W	F	P F	
0x3110	5150	DcSourceVoltageHigh	DC source voltage above max. DC source voltage limit.		X			
0x3120	4165	Grid Voltage Low	A grid voltage (RMS) below the normal operating range is detected.		X	X		C
0x3120	5151	DcSourceVoltageLow	DC source voltage below min. DC source voltage limit.		X			
0x3130	4160	Missing Grid Phase	A missing phase is detected on the grid side. Check the grid supply, cables, connections, and fuses.		X	X		C
0x3130	4163	Grid Imbalance	A large imbalance of the grid voltages is detected. Check for uneven loads on the grid.		X	X		C
0x3140	4161	Grid Frequency Out of Range	A grid frequency outside the normal operating range is detected.		X	X		C
0x3140	4166	Grid Synchronization Error	The drive is unable to maintain the synchronization to the grid voltage.		X	X		C
0x3211	4144	DC-link Voltage High 2	The voltage of the DC link is above the normal operating range. Can be caused by too fast motor braking or grid transients. Increase deceleration time, enable the overvoltage controller, use AC brake, or use a brake resistor while braking.		X	X		C
0x3212	4145	DC-link Voltage High 1	The voltage of the DC link is above the normal operating range and has reached a critical level. Can be caused by too fast motor braking or grid transients. Increase deceleration time, enable the overvoltage controller, use AC brake, or use a brake resistor while braking.		X	X		C
0x3221	4146	DC-link Voltage Low	The DC-link voltage is below the normal operating range. Try to enable undervoltage protection to keep the drive running as long as possible.		X	X		C
0x32FF	4147	DC-link Voltage Ripple	Excessive voltage ripple has been detected on the main DC-link capacitors. This can be caused by an imbalance of the grid. Reduce the output power.		X	X		C

Table 38: Summary Table (continued)

Group Number (Hex)	Number (Decimal)	Display Name	Description	Type of Event				Converter action
				I	W	F	P F	
0x32F F	4148	DC-link Imbalance	An imbalance across the DC-link capacitors is detected. The imbalance can be caused by a component fault of the DC link. If the fault remains after resetting the drive, service is required.		X	X		C
0x411 0	4099	Ambient Temp. High	The ambient temperature is too high. Check the temperature and cooling conditions. Lower the temperature or improve the cooling conditions.		X			
0x421 0	4107	Brake Chopper Temp. Limit	The temperature of the brake chopper heat sink is at the upper limit of the normal temperature range. Check cooling and heat sink conditions. Reduce the generated regenerative power.		X			
0x421 0	4108	Brake Chopper Temp. High 1	The temperature of the brake chopper heat sink has exceeded the normal temperature range. Check cooling and heat sink conditions. Reduce the generated regenerative power.		X	X		C
0x421 0	4109	Brake Chopper Temp. High 2	The temperature of the brake chopper heat sink has reached a critical level. Check cooling and heat sink conditions. Reduce the generated regenerative power.		X	X		C
0x422 0	4106	Brake Chopper Temp. Low	The temperature of the brake chopper heat sink is too low. Check the ambient temperature. Increase the ambient temperature or consider an external heater to increase the temperature around the drive.		X	X		C
0x428 0	5132	Temp. Protection 1	Temperature protection 1 is triggered. The temperature has exceeded the configured value.		X	X		RC
0x428 0	5133	Temp. Protection 2	Temperature protection 2 is triggered. The temperature has exceeded the configured value.		X	X		RC
0x428 0	5134	Temp. Protection 3	Temperature protection 3 is triggered. The temperature has exceeded the configured value.		X	X		RC

Table 38: Summary Table (continued)

Group Number (Hex)	Number (Decimal)	Display Name	Description	Type of Event				Converter action
				I	W	F	P	
0x4280	5135	Temp. Protection 4	Temperature protection 4 is triggered. The temperature has exceeded the configured value.		X	X		RC
0x4280	5136	Temp. Protection 5	Temperature protection 5 is triggered. The temperature has exceeded the configured value.		X	X		RC
0x4280	5137	Temp. Protection 6	Temperature protection 6 is triggered. The temperature has exceeded the configured value.		X	X		RC
0x4280	5138				X			
0x4280	5147	Temp. Protection 7	Temperature protection 7 is triggered. The temperature has exceeded the configured value.		X	X		RC
0x4280	5148	Temp. Protection 8	Temperature protection 8 is triggered. The temperature has exceeded the configured value.		X	X		RC
0x4280	5149	Temp. Protection 9	Temperature protection 9 is triggered. The temperature has exceeded the configured value.		X	X		RC
0x4280	5154	Temp. Protection 10	Temperature protection 10 is triggered. The temperature has exceeded the configured value.		X	X		RC
0x4281	5143	Thermistor Monitor 1	The input of thermistor monitor 1 has exceeded the 4 kilo ohm threshold.			X		C
0x4281	5144	Thermistor Monitor 2	The input of thermistor monitor 2 has exceeded the 4 kilo ohm threshold.			X		C
0x4281	5145	Thermistor Monitor 3	The input of thermistor monitor 3 has exceeded the 4 kilo ohm threshold.			X		C
0x42FF	4200	Power Option Temp. High 1	The temperature of a power option has exceeded the normal temperature range. Check the cooling conditions. Reduce the load or the ambient temperature.		X	X		RC

Table 38: Summary Table (continued)

Group Number (Hex)	Number (Decimal)	Display Name	Description	Type of Event				Converter Action
				I	F	P	F	
0x42F F	4201	Power Option Temp. High 2	The temperature of a power option has reached a critical level. Check the cooling conditions. Reduce the load or the ambient temperature.		X	X		RC
0x42F F	4202	Power Option Temp. Low	The temperature of a power option component is too low. Check the ambient temperature. Increase the ambient temperature or consider an external heater to increase the temperature around the power option.		X	X		RC
0x42F F	4203	Power Option Temp. Limit	The temperature of a power option component is at the upper limit of the normal temperature. Check the cooling conditions. Reduce the load or the ambient temperature.		X			
0x42F F	4204	Power Option Temp. Imbal. 1	The thermal imbalance between the power option components exceeds the normal operating range.		X	X		RC
0x42F F	4205	Power Option Temp. Imbal. 2	An excessive thermal imbalance between power option components has been detected.		X	X		RC
0x42F F	4206	Power Option Temp. Imbal. Limit	The thermal imbalance between the power option components is at the upper limit of the normal operating range.		X			
0x431 0	4103	Inverter Temp. Limit	The temperature of the inverter heat sink is at the upper limit of the normal temperature range. Check cooling and heat sink conditions. Reduce the output current or ambient temperature. The drive may derate if the temperature is not lowered.		X			
0x431 0	4104	Inverter Temp. High 1	The temperature of the inverter heat sink has exceeded the normal temperature level. Check cooling and heat sink conditions. Reduce the output current or ambient temperature.		X	X		C
0x431 0	4105	Inverter Temp. High 2	The temperature of the inverter heat sink has reached a critical level. Check cooling and heat sink conditions. Reduce the output current to avoid a protected fault.		X	X		C

Table 38: Summary Table (continued)

Group Number (Hex)	Number (Decimal)	Display Name	Description	Type of Event				Converter Action
				I		F	P F	
0x4310	4110	IGBT Temp. High	An inverter IGBT overtemperature has been detected. Reduce the ambient temperature, the output current and/or the switching frequency. Check the cooling and the condition of the heat sink.			X		C
0x4310	4113	Rectifier Temp. Limit	The temperature of the rectifier heat sink is at the upper limit of the normal temperature range. Check cooling and heat sink conditions. Reduce the output power (torque, speed) or the ambient temperature.		X			
0x4310	4114	Rectifier Temp. High 1	The temperature of the rectifier heat sink has exceeded the normal temperature range. Check cooling and heat sink conditions. Reduce the output power (torque, speed) or the ambient temperature.		X	X		C
0x4310	4115	Rectifier Temp. High 2	The temperature of the rectifier heat sink has reached a critical level. Check cooling and heat sink conditions. Reduce the output power (torque, speed) or the ambient temperature.		X	X		C
0x4310	4117	Power Unit Temp. Limit	The internal air temperature of the drive is at the upper limit of the normal temperature range. Check cooling and heat sink conditions. Reduce the output power (torque, speed) or the ambient temperature.		X			
0x4310	4118	Power Unit Temp. High 1	The internal air temperature of the drive has exceeded its normal temperature range. Check cooling and heat sink conditions. Reduce the output power (torque, speed) or the ambient temperature.		X	X		C
0x4310	4119	Power Unit Temp. High 2	The internal air temperature of the drive has reached a critical value. Check cooling and heat sink conditions. Reduce the output power (torque, speed) or the ambient temperature.		X	X		C

Table 38: Summary Table (continued)

Group Number (Hex)	Number (Decimal)	Display Name	Description	Type of Event			Converter Action
				I	F	P F	
0x4310	4125	IGBT Temp. High	An inverter IGBT temperature has reached a critical value. Reduce the drive's output current if possible to avoid a protected fault.		X		C
0x4320	4102	Ambient Temp. Low	The drive is operated at a too low ambient temperature. Check the ambient temperature. Increase the ambient temperature or consider an external heater to increase the temperature around the drive.		X	X	C
0x4320	4112	Rectifier Temp. Low	The temperature of the rectifier heat sink is too low. Check the ambient temperature. Increase the ambient temperature or consider an external heater to increase the temperature around the drive.		X	X	C
0x4320	4116	Power Unit Temp. Low	The internal air temperature of the drive is below the normal operating range. The drive is operated at a too low ambient temperature. Consider an external heater to avoid this warning or fault.		X	X	C
0x4380	5240	Cooling Monitor	The cooling signal is missing.		X	X	C
0x43FE	4120	Control Board Temp. Low	The temperature of the control board is below the normal temperature range. The drive is operated at a too low ambient temperature. Check the ambient temperature. Increase the ambient temperature or consider an external heater to increase the temperature at the drive.		X	X	C
0x43FE	4121	Control Board Temp. Limit	The temperature of the control board is at the upper limit of the normal temperature range. Check cooling conditions and load of the control board. Reduce the load on the control board or the ambient temperature.		X		
0x43FE	4122	Control Board Temp. High 1	The temperature of the control board has exceeded its normal temperature range. Check cooling conditions and load of the control board. Reduce the load on the control board or the ambient temperature.		X	X	C

Table 38: Summary Table (continued)

Group Number (Hex)	Number (Decimal)	Display Name	Description	Type of Event				Converter Action
				I	W	F	P F	
0x43FE	4123	Control Board Temp. High 2	The temperature of the control board has reached a critical level. Check cooling conditions and load of the control board. Reduce the load on the control board or the ambient temperature.		X	X		C
0x43FF	4124	Break Chopper Temperature Imbalance	There is a temperature imbalance between 1 or more brake chopper IGBT's.		X			
0x43FF	4126	IGBT Temperature Imbalance	There is a temperature imbalance between 1 or more IGBT's.		X			
0x43FF	4127	IGBT Temperature Imbalance	An excessive thermal imbalance between the IGBT modules has been detected. Check the condition of IGBT modules their connections the cooling and the driver boards.		X			
0x43FF	4131	Temperature Imbalance Brake IGBT	There is a temperature imbalance between 1 or more brake chopper IGBT's.		X	X		C
0x43FF	4132	IGBT temperature delta	There is a temperature imbalance between 1 or more IGBT's.		X	X		C
0x5100	4641	24V Backup Mode	The drive is in 24V backup mode. The control section (including parameter configurations) and installed options are kept operational.	X				
0x5112	4640	24V Supply Fault	The 24V supply is outside its normal operating range.				X	C
0x5114	4642	3.3V Supply Low	The voltage of the internal 3.3V supply is below its normal operating range.			X		C
0x5118	4643	28V Supply Low	The voltage of the internal 28V supply is below its normal operating range.			X		C
0x51FE	4644	Gate Driver Voltage Fault	The gate driver supply voltage is outside its normal operating range.				X	C
0x51FE	4653	Gate Driver Fault	A gate driver fault is detected or a link to the gate driver is broken.			X		C
0x51FF	4645	Power Board Supply Fault	A power supply fault on the power board has been detected.				X	C
0x51FF	4646	Power Supply Voltage	A power supply voltage is outside its normal operating range.				X	C

Table 38: Summary Table (continued)

Group Number (Hex)	Number (Decimal)	Display Name	Description	Type of Event				Converter Action
				I	W	F	P F	
0x5210	4378	Current Sensor Fault	A defective current sensor or an error in the calibration of the current sensors has been detected.			X		C
0x54FD	4647	Function Disabled	The protection logic keeps the trip active until the configuration of the power unit protection levels is ready.			X		C
0x54FE	4628	STO Activated	The Safe Torque-Off (STO) is activated and an unintended restart is prevented until the STO-request has been reset.		X			C
0x54FE	4629	STO Fault Ch. A	The Safe Torque-Off (STO) is activated due to a discrepancy fault: Channel A is not activated, while channel B is activated.			X		C
0x54FE	4630	STO Fault Ch. B	The Safe Torque-Off (STO) is activated due to a discrepancy fault: Channel B is not activated, while channel A is activated.			X		C
0x54FF	4149	DC-link Short Circuit	An internal short circuit is detected in the DC link. Service is required.				X	C
0x54FF	4150	DC Capacitor Short Circuit	A short circuit in a DC-link capacitor is detected. Service is required.			X		C
0x54FF	4151	DC-link Short Circuit 2	A short circuit in the DC-link capacitor is detected. Service is required.	X			X	C
0x5530	4790	Control Data Error	A data error is detected in the control data database EEPROM.	X				
0x5530	4791	Invalid PUD	A data error has been detected in the power unit database EEPROM.			X		C
0x6100	4304	License Missing	A required license is missing.		X			
0x6100	4349	Authenticity Error	Files authenticity verification error occurred.			X		RC
0x6100	4351	System Fault	A system fault has been detected. See additional information for details.			X		C
0x6100	4357	Firmware Crash	A firmware crash occurred and detailed information is provided.			X		C
0x6100	4567	Restore Status	Provides information about the restore operation of a setting.	X				

Table 38: Summary Table (continued)

Group Number (Hex)	Number (Decimal)	Display Name	Description	Type of Event				Converter Action
				I		F	P F	
0x6100	4816	PLC Task Overrun	The high CPU load is inhibiting normal operation of the application (PLC task overrun).		X			
0x6100	4817	PLC Runtime Error	The PLC runtime has stopped responding. The application has been halted.			X		C
0x6100	4832	Node Discovery	Node discovery and configuration are in progress. The modulation is inhibited.	X				RC
0x6100	4833	Node Commissioning	Nodes are being commissioned.		X			C
0x6100	4834	Node Missing	A previously commissioned node is no longer available. The drive is waiting for the node to be available. If the node has been removed, recommission the drive.	X				
0x6100	4853	StartupOccurrence	This event masks over various events that might be active during startup, that we dont want to show the end user	X				
0x6100	4854	ResetByDemand	Drive reset is requested, and will be performed shortly	X				C
0x6100	4855	Internal Fault	An internal fault has been detected. Cycle power, check the wiring if applicable, contact the service provider if the fault persists. Note the event number for further troubleshooting directions.			X		RC
0x6100	4856	Internal Fault	An internal fault has been detected (connection from controller). Cycle power, check the internal wiring, contact the service provider if the fault persists. Note the event number for further troubleshooting directions.			X		C
0x6100	4857	Software Update	The drive is currently performing an update of the software.	X				
0x6100	5130	Quick Stop Active	Quick Stop exception active.			X		C
0x6180	5260	Event Simulation	The event with the number 5260 is simulated.		X	X		C

Table 38: Summary Table (continued)

Group Number (Hex)	Number (Decimal)	Display Name	Description	Type of Event				Converter Action
				I		F	P F	
0x6181	4980	A Digital Input terminal is unknown by system	A digital input terminal has been selected that is unknown by system. Maybe an option has been moved or removed.		X			
0x6181	4981	A Digital Output terminal is unknown by system	A digital output terminal has been selected that is unknown by system. Maybe an option has been moved or removed.		X			
0x6181	4982	An Analog Input terminal is unknown by system	An analog input terminal has been selected that is unknown by system. Maybe an option has been moved or removed.		X			
0x6181	4983	An Analog Output terminal is unknown by system	An analog output terminal has been selected that is unknown by system. Maybe an option has been moved or removed.		X			
0x6181	4984	A Digital Output occupied	A digital output is in use by an other function or fieldbus. If a Fieldbus has taken control over a terminal, it has priority over parameter selection.		X			
0x6181	4985	An Analog Output occupied	An analog output is in use by an other function or fieldbus. If a Fieldbus has taken control over a terminal, it has priority over parameter selection.		X			
0x61F7	4800	Low Storage Space	The available storage space for the file system is low.	X				
0x61F7	4801	Data Logger Storage	Volume restriction limits are preventing additional data logger capture files from being stored.		X			
0x61F7	4802	Event Logger Storage	Volume restriction limits are preventing additional event log capture files from being stored.		X			
0x61FB	4600	Option Communication Fault	A fault of the communication with an option has been detected. Cycle power, check that the option is properly installed, contact the Danfoss supplier or the service department if the fault persists. Note the event number for further troubleshooting directions.			X		RC

Table 38: Summary Table (continued)

Group Number (Hex)	Number (Decimal)	Display Name	Description	Type of Event				Converter Action
				I	F	P	F	
0x61FB	4601	Internal Communication Fault	An internal communication fault has been detected. Cycle power, check the wiring if applicable, contact the service provider if the fault persists. Note the event number for further troubleshooting directions.		X			
0x61FB	4602	Option Communication Fault	A fault of the communication with an option has been detected. Cycle power, check that the option is properly installed, contact the Danfoss supplier or the service department if the fault persists. Note the event number for further troubleshooting directions.			X		C
0x61FB	4607	Internal Communication Fault	An internal communication fault has been detected. Cycle power, check the wiring if applicable, contact the Danfoss supplier or the service department if the fault persists. Note the event number for further troubleshooting directions.			X		C
0x61FB	4631	Internal Communication Fault	An internal communication fault has been detected. Cycle power, check the wiring if applicable, contact the Danfoss supplier or the service department if the fault persists. Note the event number for further troubleshooting directions.			X		RC
0x61FB	4632	Internal Communication Fault	An internal communication fault has been detected. Cycle power, check the wiring if applicable, contact the service provider if the fault persists. Note the event number for further troubleshooting directions.		X			
0x61FC	4605	Internal Communication Fault	An internal communication fault has been detected. Cycle power, check the wiring if applicable, contact the service provider if the fault persists. Note the event number for further troubleshooting directions.			X		C

Table 38: Summary Table (continued)

Group Number (Hex)	Number (Decimal)	Display Name	Description	Type of Event			Converter Action
				I	F	P F	
0x61FC	4606	Internal Communication Fault	An internal communication fault has been detected. Cycle power, check the wiring if applicable, contact the Danfoss supplier or the service department if the fault persists. Note the event number for further troubleshooting directions.		X		C
0x61FC	4639	High Speed Bus Sync Error	Internal error detected with high-speed bus connection to parallel control unit.		X		C
0x61FC	4648	High Speed Bus Error	Internal error detected with high-speed bus connection to parallel control unit.		X		C
0x61FC	4858	Internal Fault	An internal fault has been detected. The power system has not received the required reference for modulation. Cycle power, check the wiring if applicable, contact the Danfoss supplier or the service department if the fault persists. Note the event number for further troubleshooting directions.		X	X	C
0x61FC	4859	Internal Fault	An internal fault (connection from power system) has been detected. Cycle power, check the internal wiring, contact the service provider if the fault persists. Note the event number for further troubleshooting directions.		X	X	C
0x61FC	4860	Unexpected Time Adjust	An internal fault (unexpected time adjustment) has been detected. Cycle power, check the internal wiring, contact the service provider if the fault persists. Note the event number for further troubleshooting directions.		X		C
0x61FC	4861	Synchronization Fault	An internal fault (time synchronization error between controller and power system) has been detected. Cycle power, check the internal wiring, contact the service provider if the fault persists. Note the event number for further troubleshooting directions.		X		C
0x61FC	4862	PDS	Internal error detected with high-speed bus connection from controller.		X		C

Table 38: Summary Table (continued)

Group Number (Hex)	Number (Decimal)	Display Name	Description	Type of Event				Converter Action
				I		F	P	
0x61FC	4863	Internal Fault	An internal fault (connection with power system) has been detected. Cycle power, check the internal wiring, contact the service provider if the fault persists. Note the event number for further troubleshooting directions.			X		C
0x6320	4350	Configuration Error	An invalid system configuration has been detected.		X	X		C
0x70FF	4128	Control Fan Failure	The control board cooling fan is not running at the commanded speed.		X			
0x70FF	4129	Main Fan Failure	The main cooling fan is not following its reference speed. Check the fan's wiring and whether its blocked or polluted. Replace the fan if necessary.		X			
0x70FF	4130	Internal Fan Failure	The internal fan is running below its reference speed. Check the fan's wiring and whether its blocked or polluted. Replace the fan if necessary.		X			
0x70FF	4133	LCL Fan Speed Fault	LCL cooling fan not tracking commanded output.			X		C
0x7111	4403	Brake Ch. Switch Shorted	A short circuit of the brake chopper switch has been detected, which can be dangerous. Disconnect power. Service is required.		X	X		C
0x7113	4400	Brake Chopper Overload	A brake chopper overcurrent has been detected. Reduce the brake voltage level and check the rating of the brake resistor.		X		X	C
0x7113	4401	Brake Resistor Temp. High	The brake resistor temperature is too high. Check the rating of the brake resistor and cooling conditions. Reduce the generated regenerative power.		X	X		C
0x7113	4402	Brake Resistor Missing	The brake resistor or its connection is missing.		X	X		C
0x7113	4404	Brake Failure	A brake failure is detected, further testing will clarify the failure source. Coast first to run the test.		X			C

Table 38: Summary Table (continued)

Group Number (Hex)	Number (Decimal)	Display Name	Description	Type of Event				Converter Action
				I		F	P F	
0x7120	4177	Motor Thermal Overload	A thermal overload of the motor has been detected. Check if the shaft torque is too high.		X	X		C
0x7120	4178	Motor Speed High	The motor speed is above the normal operating range.		X	X		C
0x7120	4179	AMA Current Low	The nominal current of the motor is too low for accurate results of automatic motor adaptation (AMA).		X			
0x7120	4180	Rotor Angle Detection Error	Rotor angle detection has failed. This might be as the motor is not suited to the drive or the motor is missing.		X	X		C
0x7120	4181	Low Motor Saliency For High Frequency Injection Mode	Motor saliency is too low for HF injection mode.		X	X		C
0x7122	4182	Motor Sync Loss	Select the drive response if synchronization between motor and drive is lost. This is only used when using a permanent magnet or synchronous reluctance motor.		X	X		C
0x7180	5380	PreChargeFailed	Pre charge failed.			X		C
0x72FF	4417	Feedback Option Fault	The Feedback Option is indicating a fault condition.			X		C
0x7310	4418	Bad Speed Feedback	Speed Feedback value is not reliable.			X		C
0x7500	4638	Drive to Drive Connection Lost	Drive to drive connection is lost.		X	X		C
0x7580	5141	Control Panel Connection Lost	The connection to the control panel was lost. Panel control has been released.					
0x7580	5142	PC Tool Connection Lost	The connection to the PC tool was lost. PC control has been released.					
0x8100	4256	Address Conflict	The fieldbus has identified an Address Conflict on the network which made the device back off.		X			

Table 38: Summary Table (continued)

Group Number (Hex)	Number (Decimal)	Display Name	Description	Type of Event				Converter Action
				I		F	P F	
0x8100	4257	Ethernet Cable Fault	At link down a measurement is done to measure the distance to the far end of the cable, indicating where the fault has occurred. This warning occurs at distances > 4 m and Link State Change Down. Actual distance shown in detailed info.		X			
0x8100	4258	Invalid Fieldbus Configuration	An issue due to an invalid configuration of the fieldbus connection has been detected. Features not supported by the device, mismatch between configured and actually available features or modules not available in the device. See additional detail info.	X				
0x8100	4260	Redundant Controller Missing	One or more of the expected fieldbus controllers are missing.		X			
0x8100	4261	Fieldbus Topology Mismatch	The current fieldbus topology does not match the topology provided at commissioning time.		X			
0x8100	4263	Ethernet Link Status Changed	There has been detected a change of the Ethernet link status. Additional info has details about which port and state.	X				
0x8100	4265	Ethernet Redundancy Error	Primary or backup physical paths has been detected missing.		X			
0x8100	4266	X1 Cable Redundancy	Indicates that physical path from X1 interface to the controller is missing or wrongly configured.		X			
0x8100	4267	X2 Cable Redundancy	Indicates that physical path from X2 interface to the controller is missing or wrongly configured.		X			
0x8100	4268	FieldbusStartUp	Internal event to mask away TopologyMismatch event during startup	X				
0x8100	4269	Network Time Protocol	Information of Network Time Protocol server. See detailed info.	X				
0x8100	4280	Controller Not in Run	Controller not in RUN state.	X				
0x8100	4281	Interface Configuration Change	Interface configuration changed. See detailed info.	X				

Table 38: Summary Table (continued)

Group Number (Hex)	Number (Decimal)	Display Name	Description	Type of Event				Converter Action
				I		F	P F	
0x8100	5161	Fieldbus Watchdog Supervision	Fieldbus watchdog supervision has detected too long delay between fieldbus data updates.					
0x81FD	4270			X				
0x81FD	4271			X				
0x81FD	4272			X				
0x81FD	4273	No EtherCAT Connection	No EtherCAT communication is currently established. Will happen during start-up until first connection is established. Or if all connections has stopped (gracefully or disruptive).	X				
0x81FD	4282	No Modbus TCP Connection	No Modbus RTU communication is currently established. Occurs during start-up until first connection is established, or if all connections has stopped (gracefully or disruptive).	X				
0x81FE	4274				X			
0x81FE	4275				X			
0x81FE	4276				X			
0x81FE	4277	Loss of EtherCAT Connection	One or more of the fieldbus I/O connections has failed. This can happen when an established fieldbus I/O Connection has been disrupted by e.g cable break or powercut of PLC or other infrastructure components.		X			
0x81FE	4283	Loss of Modbus RTU Connection	One or more of the fieldbus I/O connections has failed. This can happen when an established fieldbus I/O connection has been disrupted by for example cable break or powercut of PLC or other infrastructure components.		X			

Table 38: Summary Table (continued)

Group Number (Hex)	Number (Decimal)	Display Name	Description	Type of Event				Converter Action
				I		F	P F	
0x81FF	4278					X		C
0x81FF	4279	Secondary Process Data Timeout	The fieldbus I/O Data has not been updating any of the process data monitored by the secondary process data monitor (Watchdog2). This can happen when the fieldbus has lost control or the current transferred I/O data is not valid.			X		C
0x8611	4192	Position Following Error	The actual position is outside the allowed range of the position error window around a position demand value for longer than the position error delay.		X			
0x8612	4193	Position Limit	Motor position is outside the allowed range [PositionMin, PositionMax].		X	X		C
0x8612	4194	Position Command Rejected	Position command was rejected because of position software end limit.		X			
0x8612	4195	Hardware End Limit	The positioning controller detected that the drive is exceeding the hardware end Limits.		X	X		C
0xFF01	5123	External Exception 1	External Exception 1.			X		C
0xFF01	5124	External Exception 2	External Exception 2.			X		C

9.5 Troubleshooting of Events

This section covers the faults and warnings that can occur while the application software is running on the drive. Possible causes and remedies are given for each event.

9.5.1 Event Type, 0x2130-4356 (8496–4356)

NOTICE

EVENT NAME: DESAT

Reason: Short circuit is detected in the output of the drive. Gate driver desaturation error has occurred.

- Cause: Short circuit detected.
- Remedy: Fix the short circuit by checking, replacing, or isolating wires.

9.5.2 Event Type, 0x2130-4370 (8496–4370)

NOTICE

EVENT NAME: I_{MAX2}

Reason: Output short circuit is detected.

- Cause: Short circuit detected.
- Remedy: Fix the short circuit by checking, replacing, or isolating wires.

9.5.3 Event Type, 0x2311-4097 (8977–4097)

NOTICE

EVENT NAME: INVERTERTHERMAL

Reason: DC/DC Converter thermal overload is detected.

- Cause: Sudden change in load is causing thermal overload.
- Remedy: Inspect the load and cooling. If problem persists, check that sizing of the converter is fit for the application.

9.5.4 Event Type, 0x2311-4369 (8977–4369)

NOTICE

EVENT NAME: I_{MAX1}

Reason: A continuous DC/DC converter output overcurrent is detected.

- Cause: Sudden load step is causing too high current.
- Remedy: Inspect the load. If problem persists, check that sizing of the converter is fit for the application.

NOTICE

EVENT NAME: I_{MAX0}

Reason: A continuous DC/DC Converter output overcurrent is detected.

- Cause: Sudden change in the DC load.
- Remedy: Inspect the DC load. If the problem persists, check that the sizing of the converter is appropriate for the application.

9.5.5 Event Type, 0x3211-4144 (12817–4144)

NOTICE

EVENT NAME: UDCOVERVOLT

Reason: The DC-link voltage has exceeded the normal operating range.

- Cause: Sudden reduction in load of the DC-link while power source is still feeding the DC-link.
- Cause: Too high power supply compared to load. For example, due to unstable power supply of the DC-link.
- Remedy: Ensure the load balance of the system. Verify power management system operation. Change control principle of the system or optimize converter controller tuning in case the dynamics of the system are causing the issue.
- Cause: Sudden change in supply voltage or frequency (of the adjacent AC power generation).
- Remedy: Check supply voltage or frequency.
- Cause: High overvoltage spikes in supply voltage.
- Remedy: Activate the overvoltage controller.
- Cause: A continuous high DC-link voltage.
- Remedy: Inspect the voltage supply.
- Cause: Unstable DC power source in micro grid mode.
- Remedy: Check DC source.
- Cause: Incorrect grid frequency.
- Remedy: Check grid conditions.

9.5.6 Event Type, 0x3211-4144 (12817–4144)

NOTICE

EVENT NAME: UDCOVERVOLTSLOW

Reason: The DC-link voltage has exceeded the normal operating range.

- Cause: Sudden reduction in load of the DC-link while power source is still feeding the DC-link.
- Cause: Too high power supply compared to load. For example, due to unstable power supply of the DC-link.
- Remedy: Ensure the load balance of the system. Verify power management system operation. Change control principle of the system or optimize converter controller tuning in case the dynamics of the system are causing the issue.
- Cause: Sudden change in supply voltage or frequency (of the adjacent AC power generation).
- Remedy: Check supply voltage or frequency.
- Cause: High overvoltage spikes in supply voltage.
- Remedy: Activate the overvoltage controller.
- Cause: A continuous high DC-link voltage.
- Remedy: Inspect the voltage supply.

9.5.7 Event Type, 0x3221-4146 (12833–4146)

NOTICE

EVENT NAME: UDCUNDERVOLT

Reason: The DC-link voltage is below normal operating range.

- Cause: Too low supply voltage or limited supply power.
- Remedy: Inspect the voltage supply.
- Cause: An internal fault is detected in the device.
- Remedy: Inspect the device.
- Cause: Probability of a blown input fuse.
- Remedy: Inspect the fuses.
- Cause: External charge switch is not closed.
- Remedy: Inspect the charge switch.

9.5.8 Event Type, 0x4210-4103 (16912–4103)

NOTICE

EVENT NAME: TLIMITM

Reason: IGBT temperature above normal operating range is detected.

- Cause: Very high load is detected.
- Remedy: Inspect high load.
- Cause: Coolant temperature is very high or insufficient coolant flow.
- Remedy: Inspect the cooling unit.

9.5.9 Event Type, 0x4210-4104 (16912–4104)

NOTICE
<p>EVENT NAME: TMAX1M</p> <p>Reason: IGBT temperature above normal operating range is detected.</p> <ul style="list-style-type: none"> - Cause: Very high load is detected. - Remedy: Inspect high load. - Cause: Coolant temperature is very high or insufficient coolant flow. - Remedy: Inspect the cooling unit.

9.5.10 Event Type, 0x4210-4110 (16912–4110)

NOTICE
<p>EVENT NAME: IGBTMODELOVERTEMPFAULT</p> <p>Reason: Overtemperature is detected in IGBT.</p> <ul style="list-style-type: none"> - Cause: Very high load is detected. - Remedy: Inspect high load. - Cause: Coolant temperature is very high or insufficient coolant flow. - Remedy: Inspect the cooling unit.

9.5.11 Event Type, 0x4210-4125 (16912–4125)

NOTICE
<p>EVENT NAME: IGBTTOVERTEMPFAULT</p> <p>Reason: Overtemperature is detected in IGBT.</p> <ul style="list-style-type: none"> - Cause: Very high load is detected. - Remedy: Inspect high load. - Cause: Coolant temperature is very high or insufficient coolant flow. - Remedy: Inspect the cooling unit.

9.5.12 Event Type, 0x7500-5141 (29952–5142)

NOTICE
<p>EVENT NAME: CONTROL PANEL CONNECTION LOSS</p> <p>Reason: The drive has lost connection with the control panel when local control is the active control place.</p> <ul style="list-style-type: none"> - Cause: Cable connection to the control panel is damaged or unplugged. - Remedy: Replace damaged cable. - Remedy: Replug the cable. - Cause: Control unit HMI connector is damaged. - Remedy: Replace the control unit. - Cause: Control panel is damaged. - Remedy: Replace the control panel.

9.5.13 Event Type, 0x7500-5142 (29952–5142)

NOTICE

EVENT NAME: PC TOOL CONNECTION LOSS

Reason: The converter has lost connection with the PC tool when the PC tool is the active control place.

- Cause: Ethernet cable is not properly connected or broken.
- Remedy: Check the ethernet cable

9.5.14 Event Type, 0x7580-5120 (30080–5120)

NOTICE

EVENT NAME: FIELDBUS COMMUNICATION ERROR

Reason: Error is detected during fieldbus communication with the product.

- Cause: Fieldbus connection issues.
- Remedy: Inspect the fieldbus cabling and installation.
- Cause: Fieldbus master cannot be controlled.
- Remedy: Check the behavior of fieldbus master.

9.5.15 Event Type, 0x7580-5121 (30080–5121)

NOTICE

EVENT NAME: FIELDBUS WATCHDOG

Reason: A fault is issued as a change in the state of the watchdog bit in the fieldbus control word is not detected within the specified watchdog delay time.

- Cause: Fieldbus connection issues.
- Remedy: Inspect the fieldbus cabling and installation.
- Cause: Fieldbus master cannot be controlled.
- Remedy: Check the behavior of fieldbus master.
- Cause: Watchdog delay specified is too short.
- Remedy: Verify configuration of watchdog delay parameters.

9.5.16 Event Type, 0xFF03-5123 (65283–5123)

NOTICE

EVENT NAME: EXTERNAL EXCEPTION 1

Reason: External fault or warning is triggered by digital input.

- Cause: External fault or warning is triggered by digital input.
- Remedy: Verify the conditions which trigger the external fault or warning.

9.5.17 Event Type, 0xFF03-5124 (65283–5124)

NOTICE**EVENT NAME: EXTERNAL EXCEPTION 2**

Reason: External fault or warning is triggered by digital input.

- Cause: External fault or warning is triggered by digital input.
- Remedy: Verify the conditions which trigger the external fault or warning.

9.5.18 Event Type, 0xFF09-5130 (65289–5130)

NOTICE**EVENT NAME: QUICK STOP EXCEPTION**

Reason: Quick stop is triggered from digital input or fieldbus.

- Cause: Cable connection to the HMI is damaged or unplugged.
- Remedy: Replace damaged cable.
- Remedy: Replug the cable.

9.5.19 Event Type, 0x4210-4105 (16912–4105)

NOTICE

EVENT NAME: TMAX2M

Reason: IGBT temperature above normal operating range is detected.

- Cause: Very high load is detected.
- Remedy: Inspect high load.
- Cause: Coolant temperature is very high or insufficient coolant flow.
- Remedy: Inspect the cooling unit.

9.5.20 Event Type, 0x4210-5143 (16912–5143)

NOTICE

EVENT NAME: TEMPERATURE PROTECTION 1

Reason: Thermistor has triggered a high temperature fault or warning.

- Cause: Device connected to thermistor is overheated.
- Remedy: Check the device temperature.
- Cause: Temperature sensor cable is damaged.
- Remedy: Check temperature sensor connections.

9.5.21 Event Type, 0x4210-5144 (16912–5144)

NOTICE

EVENT NAME: TEMPERATURE PROTECTION 2

Reason: Thermistor has triggered a high temperature fault or warning.

- Cause: Device connected to thermistor is overheated.
- Remedy: Check the device temperature.
- Cause: Temperature sensor cable is damaged.
- Remedy: Check temperature sensor connections.

9.5.22 Event Type, 0x4210-5145 (16912–5145)

NOTICE

EVENT NAME: TEMPERATURE PROTECTION 3

Reason: Thermistor has triggered a high temperature fault or warning.

- Cause: Device connected to thermistor is overheated.
- Remedy: Check the device temperature.
- Cause: Temperature sensor cable is damaged.
- Remedy: Check temperature sensor connections.

Danfoss Drives Oy

Runsorintie 7

FIN-65380 Vaasa

drives.danfoss.com

.....
Any information, including, but not limited to information on selection of product, its application or use, product design, weight, dimensions, capacity or any other technical data in product manuals, catalog descriptions, advertisements, etc. and whether made available in writing, orally, electronically, online or via download, shall be considered informative, and is only binding if and to the extent, explicit reference is made in a quotation or order confirmation. Danfoss cannot accept any responsibility for possible errors in catalogs, brochures, videos and other material. Danfoss reserves the right to alter its products without notice. This also applies to products ordered but not delivered provided that such alterations can be made without changes to form, fit or function of the product. All trademarks in this material are property of Danfoss A/S or Danfoss group companies. Danfoss and the Danfoss logo are trademarks of Danfoss A/S. All rights reserved.
.....

M00305

