

Data Sheet

LDU20/24

Closed Circuit Axial Piston Transmission

For more than 40 years, Danfoss has been developing state-of-the-art components and systems for mobile machinery used in off-highway operations around the world. We have become a preferred supplier by offering the best of what really matters: The hardware inside your vehicle application.

The LDU20/24 was designed as a one housing U-style transmission. The design has been optimized to put a slipper piston pump in the same size as traditional no slipper piston transmissions (BDU).

It houses a variable axial piston pump with fixed displacement axial piston motor to provide the infinite gear ratio in a compact size.

This design provides higher life and performance in the same package and is well suited for turf care, compact utility tractors and agricultural vehicles.

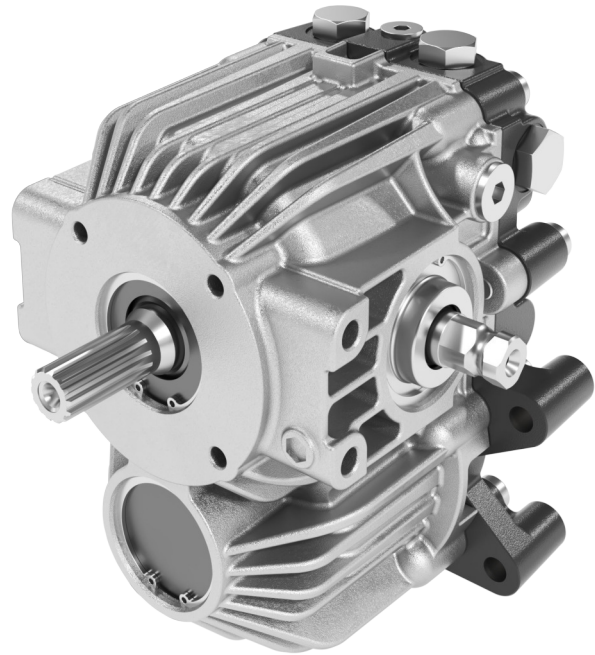

Features

Designed for Durability and Flexibility

- Best in class efficiency by male slipper design
- Longer life kit and higher duty capability in the most compact design in its class
- Shortest shaft center-line distance in it's class
- Same shaft center-line as traditional Bantam Duty U-style (BDU) transmissions (shoeless piston type)

Installation and Packaging benefits

- Optimized for shortest distance between shaft center lines
- U-style layout in housing able to mount as either Z- or U- shaft configurations
- Pump and motor in single housing
- Reduced noise
- Supply charge pressure and case drains directly through the transmission (no hoses)

Controls

- Direct Displacement Control (DDC)
- Low operating force

Options

- Bypass valve
- High Pressure Relief Valves (HPRV)
- Charge Pressure Relief Valve (CPRV)
- Orifice to increase neutral deadband

Comprehensive technical literature is online at www.danfoss.com

Technical specifications

Features		Unit	Value
Displacement	Pump side	cm ³ [in ³]	LDU20: 0 - 20.0 [0 - 1.22] LDU24: 0 - 24.0 [0 - 1.46]
	Motor side		LDU20: 20.0 [0 - 1.22] LDU24: 24.0 [0 - 1.46]
Weight, (dry)		kg [lb]	14.1 [31.1]
Input speed	Min. for external charge supply	min ⁻¹ (rpm)	500
	Min. for full performance		1300
	Rated		3400
	Maximum		3800
System pressure	Max. working pressure*	bar [psi]	300 [4350]
	Max. pressure		345 [5000]
Case pressure	Rated	bar [psi]	1 [14.5]
	Maximum		3 [43.5]

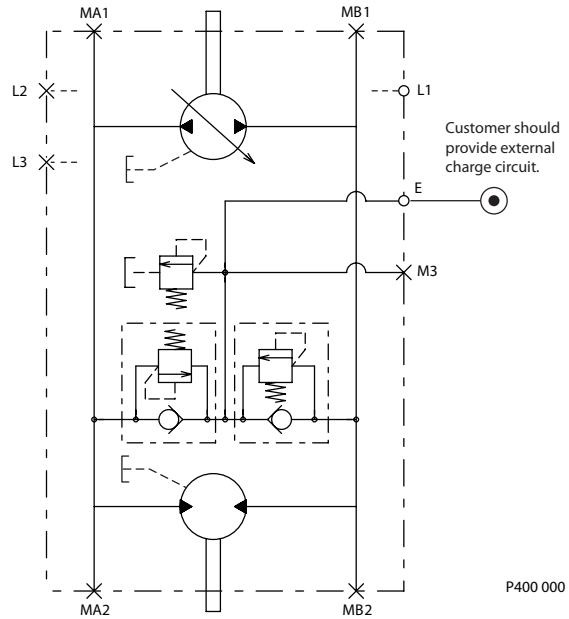

* Applied pressures above maximum working pressure requires Danfoss application approval.

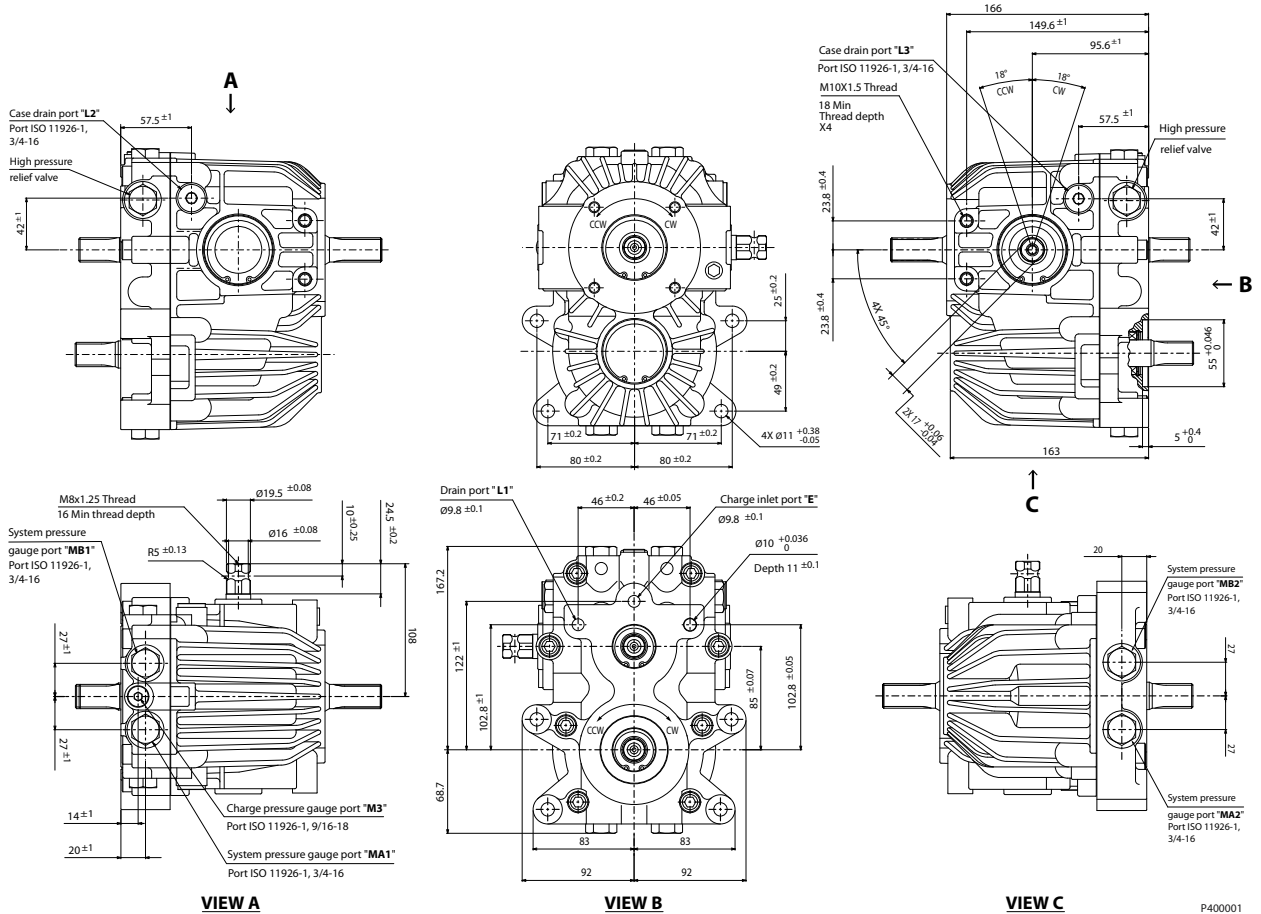

Danfoss can accept no responsibility for possible errors in catalogues, brochures and other printed material. Danfoss reserves the right to alter its products without notice. This also applies to products already on order provided that such alterations can be made without subsequent changes being necessary in specifications already agreed. All trademarks in this material are property of the respective companies. Danfoss and the Danfoss logotype are trademarks of Danfoss A/S. All rights reserved.