

Installation Guide

VACON® RS485 and CAN Bus Option Boards

OPTE3/E5, OPTC3/C5, OPTE2/E8, OPTC2/C8, OPTCJ, OPTE6, OPTE7,
OPTC6, OPTC7, OPTC4



Contents

1	Introduction	5
1.1	Purpose of this Installation Guide	5
1.2	Additional Resources	5
1.3	Manual Version	5
1.4	Product Overview	5
1.4.1	RS485-based Serial Bus Option Boards	5
1.4.2	CAN bus-based and Other Option Boards	6
1.4.3	VACON® 100 Family Internal RS485 Fieldbus Protocols	6
2	Safety	7
2.1	Safety Symbols	7
2.2	Safety Instructions	7
3	Installing	8
3.1	Installing Option Board in VACON® NXP and NXS	8
3.2	Installing Option Board in VACON® 100 INDUSTRIAL and FLOW	11
3.3	Installing Option Board in VACON® 100 X	16
3.4	Installing Option Board in VACON® 20	19
3.4.1	Installing Option Board in VACON® 20, MI1–MI3	19
3.4.2	Installing Option Board in VACON® 20, MI4–MI5	25
3.5	Installing Option Board in VACON® 20 X and 20 CP	29
4	Cabling	33
4.1	General Cabling Instructions for Fieldbus	33
4.1.1	Cable Routing	33
4.1.2	Strain Relief	34
4.2	General Cabling Instructions for RS485	34
4.3	Cable Requirements for CAN Type Option Boards	35
4.4	Cable Requirements for LON Type Option Boards	36
4.5	Fieldbus Connectors	36
4.6	Stripping the Cables	37
4.7	Grounding the Cable Shield	37
5	RS485-based Option Boards	39
5.1	Common Information for the OPTE3/E5 and OPTE2/E8 Option Boards	39
5.1.1	The OPTE3/E5 and OPTE2/E8 Option Board Layout	39
5.1.2	The Jumpers in the OPTE3/E5 and OPTE2/E8 Option Boards	39
5.2	The OPTC3/C5 Option Board	40

5.2.1	Jumpers in the OPTC3/C5 Option Board	41
5.3	Cabling and bus termination for PROFIBUS option boards	42
5.4	The OPTE2/OPTE8 Option Boards	42
5.4.1	Exceptions in Connector Pin Outs	42
5.4.2	The Bus Terminal and Bias Resistors	43
5.4.3	Setting the Termination Resistance	44
5.5	The OPTC2/C8 and OPTCJ Option Boards	45
5.5.1	Jumpers in the OPTC2/C8, and OPTCJ Option Boards	45
6	CAN Type and Other Fieldbus Option Boards	48
6.1	The OPTE6 and OPTE7 Option Boards	48
6.1.1	The OPTE6 and OPTE7 Option Board Layout	48
6.1.2	The Jumpers in the OPTE6 and OPTE7 Option Boards	48
6.2	The OPTC6 Option Board	50
6.2.1	The OPTC6 Option Board Layout	50
6.2.2	The Jumpers in the OPTC6 Option Board	50
6.3	The OPTC7 Option Board	51
6.3.1	The OPTC7 Option Board Layout	51
6.3.2	The Jumpers in the OPTC7 Option Board	52
6.4	The OPTC4 Option Board	52
6.4.1	The OPTC4 Option Board Layout	52
6.4.2	The Jumpers in the OPTC4 Option Board	53
6.4.3	The OPTC4 Option Board Topologies	53
7	Troubleshooting	55
7.1	LED Indications on PROFIBUS Option Boards	55
7.2	LED Indications on OPTE2/E8 Option Boards	56
7.3	LED Indications on OPTC2/C8 and OPTCJ Option Boards	57
7.4	LED Indications on OPTE6 Option Board	58
7.5	LED Indications on OPTC6 Option Board	59
7.6	LED Indications on OPTC7 and OPTE7 Option Boards	60
7.7	LED Indications on OPTC4 Option Board	61

1 Introduction

1.1 Purpose of this Installation Guide

This manual provides information for safe installation and commissioning of:

- RS485 serial bus based option boards including:
 - OPTE3/E5 PROFIBUS
 - OPTC3/C5 PROFIBUS
 - OPTE2/E8 RS485
 - OPTC2/C8 Modbus
 - OPTCJ BACnet
- CAN bus based and other option boards including:
 - OPTE6 CANopen
 - OPTE7 DeviceNet
 - OPTC6 CANopen
 - OPTC7 DeviceNet
 - OPTC4 LONworks

The Installation Guide is intended for use by qualified personnel only. Personnel must be familiar with the VACON[®] drive series.

Read and follow this Installation Guide before installation, and ensure that instructions for safe installation are observed. Always keep these instructions available with the drive.

1.2 Additional Resources

Resources available for the drive and optional equipment are:

- VACON[®] option board User Guides provide information on protocol-specific settings and instructions for setting up the connection.
- The Operating Guide of the AC drive provides the necessary information to get the drive up and running.
- The Application Guide of the AC drive provides more details on working with parameters and many application examples.

Supplementary publications and manuals are available from drives.danfoss.com/knowledge-center/technical-documentation/.

For US and Canadian markets:

NOTE! Download the English and French product manuals with applicable safety, warning and caution information from <https://www.danfoss.com/en/service-and-support/>.

REMARQUE Vous pouvez télécharger les versions anglaise et française des manuels produit contenant l'ensemble des informations de sécurité, avertissements et mises en garde applicables sur le site <https://www.danfoss.com/en/service-and-support/>.

1.3 Manual Version

This manual is regularly reviewed and updated. All suggestions for improvement are welcome.

The original language of this manual is English.

Table 1: Manual and Software Version

Edition	Remarks
DPD02156C	Correction to jumper settings of OPTE6 option board.

1.4 Product Overview

1.4.1 RS485-based Serial Bus Option Boards

The following table lists the RS485-based Serial Bus Option Boards compatible with VACON[®] AC drives.

Table 2: RS485-based Serial Bus Option Boards

Option board code	Option board	Compatible with AC drive	The correct slots ⁽¹⁾	Specific information
OPTE3/E5	PROFIBUS DP option board	VACON [®] NXP VACON [®] 100 INDUSTRIAL, 100X, 100 FLOW VACON [®] 20, 20 X, 20 CP	D, E	PROFIBUS, PROFIsafe
OPTC3/C5	PROFIBUS DP option board	VACON [®] NXP, NXS	D, E	PROFIBUS
OPTE2/E8	RS485 multiprotocol option board	VACON [®] NXP, NXS VACON [®] 100 INDUSTRIAL, 100X, 100 FLOW, 100 HVAC VACON [®] 20, 20X, 20CP	D, E	Modbus RTU, Metasys N2
OPTC2/C8	Modbus/N2 option board	VACON [®] NXP, NXS	D, E	Modbus RTU, Metasys N2
OPTCJ	BACnet option board	VACON [®] NXP, NXS	D, E	BACnet MSTP

¹ For option board installation in VACON[®] 20, a separate option board mounting kit is necessary.

1.4.2 CAN bus-based and Other Option Boards

The following table lists the CAN bus-based and other option boards compatible with VACON[®] AC drives.

Table 3: CAN bus-based and Other Option Boards

Option board code	Option board	Compatible with AC drive	The correct slots ⁽¹⁾	Specific information
OPTE6	CANopen option board	VACON [®] NXP, NXS VACON [®] 100 INDUSTRIAL, 100X, 100 FLOW VACON [®] 20, 20 X, 20CP	D, E	CANopen
OPTC6	CANopen option board	VACON [®] NXP, NXS	D, E	CANopen
OPTE7	DeviceNet option board	VACON [®] NXP VACON [®] 100 INDUSTRIAL, 100X, 100 FLOW VACON [®] 20, 20X, 20CP	D, E	DeviceNet
OPTC7	DeviceNet option board	VACON [®] NXP, NXS	D, E	DeviceNet
OPTC4	LonWorks option board	VACON [®] NXP, NXS VACON [®] 100 INDUSTRIAL, 100X, 100 FLOW	D, E	LonWorks

¹ For option board installation in VACON[®]20, a separate option board mounting kit is necessary.

1.4.3 VACON® 100 Family Internal RS485 Fieldbus Protocols

VACON[®]100 INDUSTRIAL, 100 X, and 100 FLOW AC drives support internally the following RS485 fieldbus protocols:

- Modbus RTU
- BACnet MSTP
- Metasys N2

For detailed installation instructions for the internal fieldbuses, see the Installation Manual of the AC drive in use.

2 Safety

2.1 Safety Symbols

The following symbols are used in this manual:

⚠ D A N G E R ⚠

Indicates a hazardous situation which, if not avoided, will result in death or serious injury.

⚠ W A R N I N G ⚠

Indicates a hazardous situation which, if not avoided, could result in death or serious injury.

⚠ C A U T I O N ⚠

Indicates a hazardous situation which, if not avoided, could result in minor or moderate injury.

N O T I C E

Indicates information considered important, but not hazard-related (for example, messages relating to property damage).

2.2 Safety Instructions

A safety guide is included in the product delivery. Read the safety instructions carefully before starting to work in any way with the system or its components.

The warnings and cautions in the safety guide give important information on how to prevent injury and damage to the equipment or the system. Read the warnings and cautions carefully and obey their instructions.

⚠ W A R N I N G ⚠

SHOCK HAZARD FROM CONTROL TERMINALS

The control terminals can have a dangerous voltage also when the drive is disconnected from mains. A contact with this voltage can lead to injury.

- Make sure that there is no voltage in the control terminals before touching the control terminals.

⚠ C A U T I O N ⚠

DAMAGE TO OPTION BOARDS

Do not install, remove, or replace option boards on the drive when the power is on. Doing this can cause damage to the boards.

- Switch off the AC drive before installing, removing, or replacing option boards on the drive.

N O T I C E

OPTION BOARD COMPATIBILITY

Installing an incompatible option board can damage the AC drive.

- Make sure that the option board being installed is compatible with the drive.

3 Installing

3.1 Installing Option Board in VACON® NXP and NXS

This topic gives instructions for Installing Option Board in VACON® NXP and NXS, FR4–FR9.

Procedure

1. In FR5–FR9, open the cover of the AC drive.
2. In FR4, remove the cable cover.

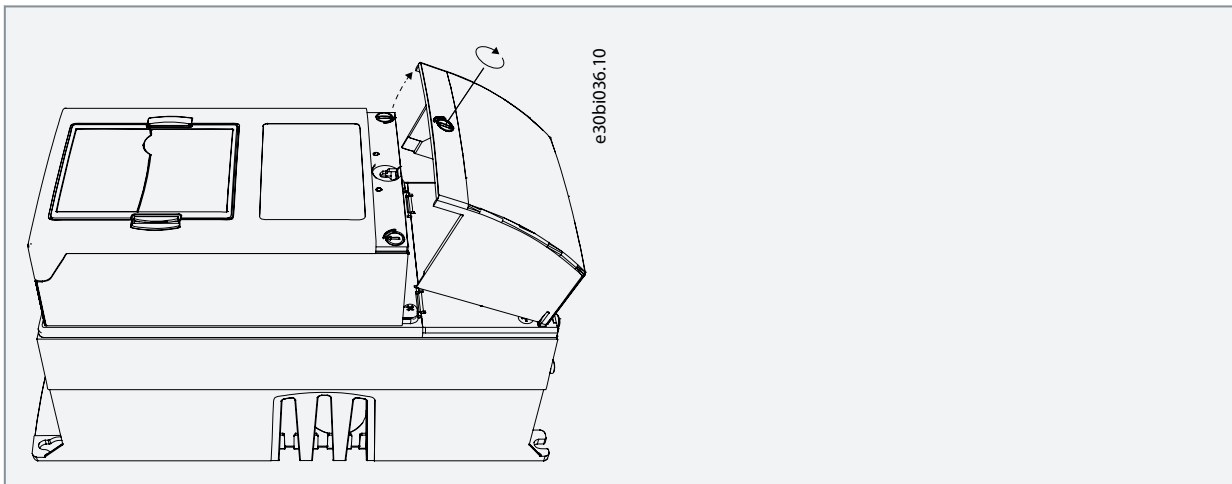

3. Open the cover of the control unit.

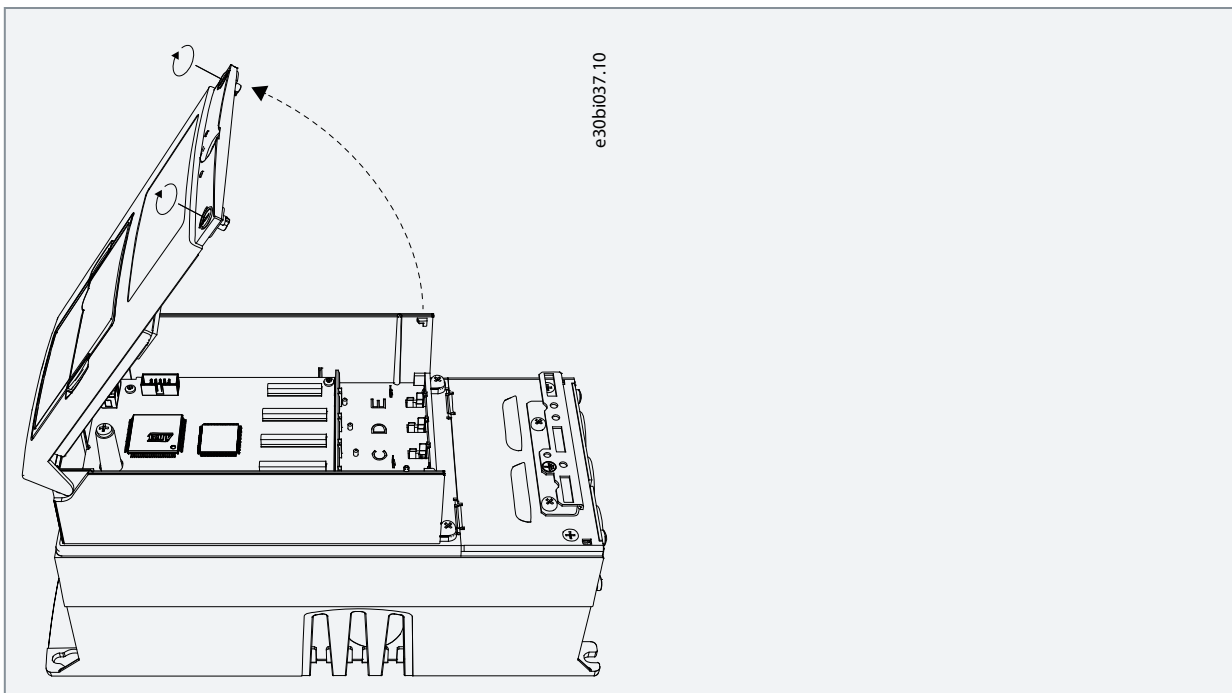

4. When installing option boards with D9 connector (OPTE5, OPTC5, OPTE8, OPTC8), replace the grounding bracket.
 - a. Remove the long grounding bracket installed in factory. It is mounted with two screws.

- b. Install the short grounding bracket delivered with the option board. Use the screws removed in step a.

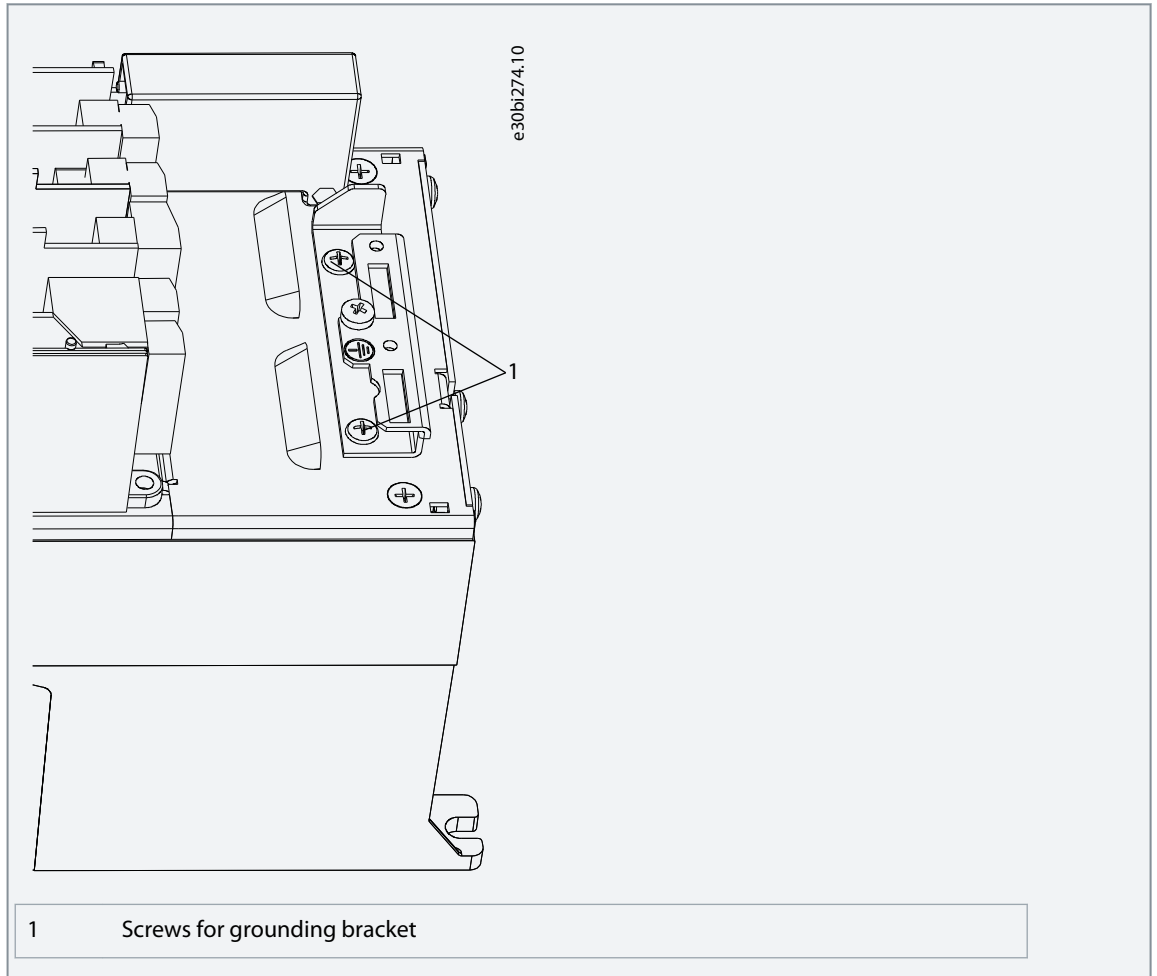

5. Install the option board into the slot E or D on the control board of the AC drive. Make sure that the grounding plate fits tightly in the clamp.

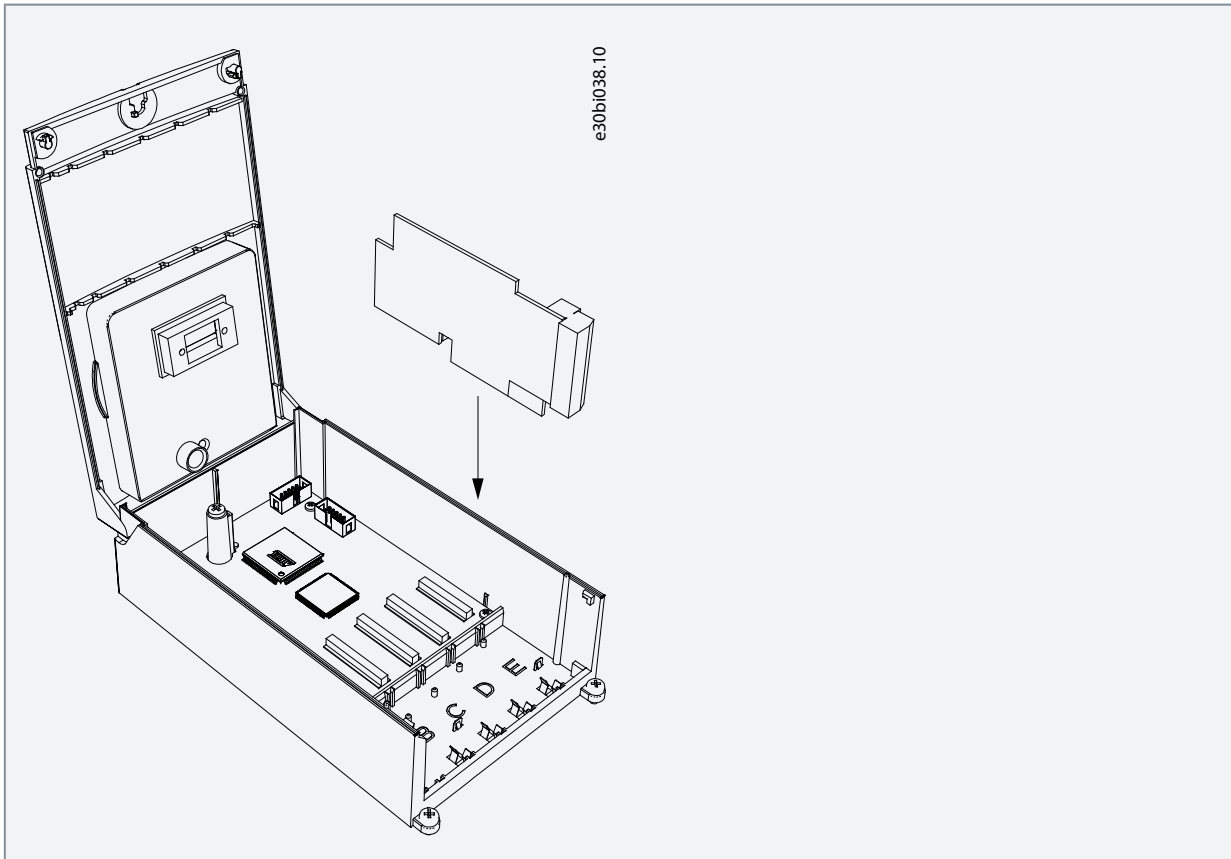

6. In IP21, cut free the opening on the cover of the AC drive for the fieldbus cable.
7. Install the cables. When installing option boards with D9 connector, use a separate grounding cable for grounding.
- a. To make a 360° grounding, strip the cables connected to the D9 connector and install the grounding cable connector around the stripped part of the cables.
 - b. Attach the cable shoe to the short grounding bracket at the other end of the grounding cable with a screw.
 - c. When the D9 connector is mounted to option board, install the grounding cable to the grounding cable connector mounted around the stripped cable in step a.

With D9 connectors on both slots D and E:

- For slot D, mount first the option board and route the grounding cable below all cables. Make sure that the cable connector is facing down.
- For slot E, route the option board grounding cable on top of the cables.

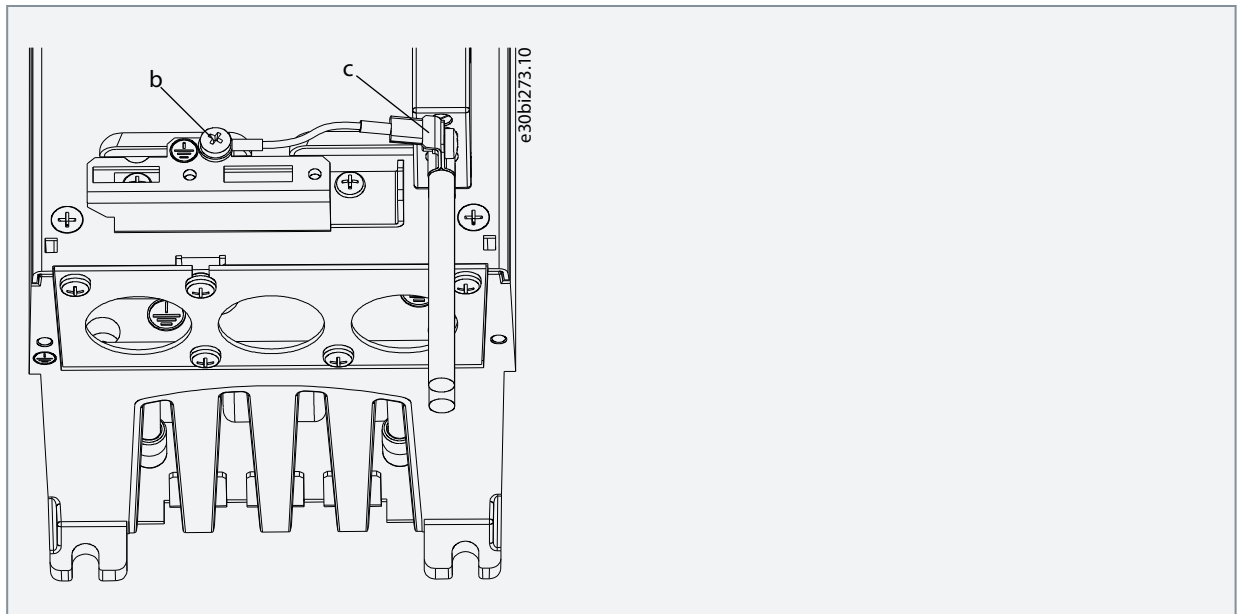

8. Close the cover of the control unit and attach the cable cover.

3.2 Installing Option Board in VACON® 100 INDUSTRIAL and FLOW

This topic gives instructions for Installing Option Board in VACON^{®E} 100 INDUSTRIAL and FLOW, MR4–MR12.

Procedure

1. Open the cover of the AC drive.

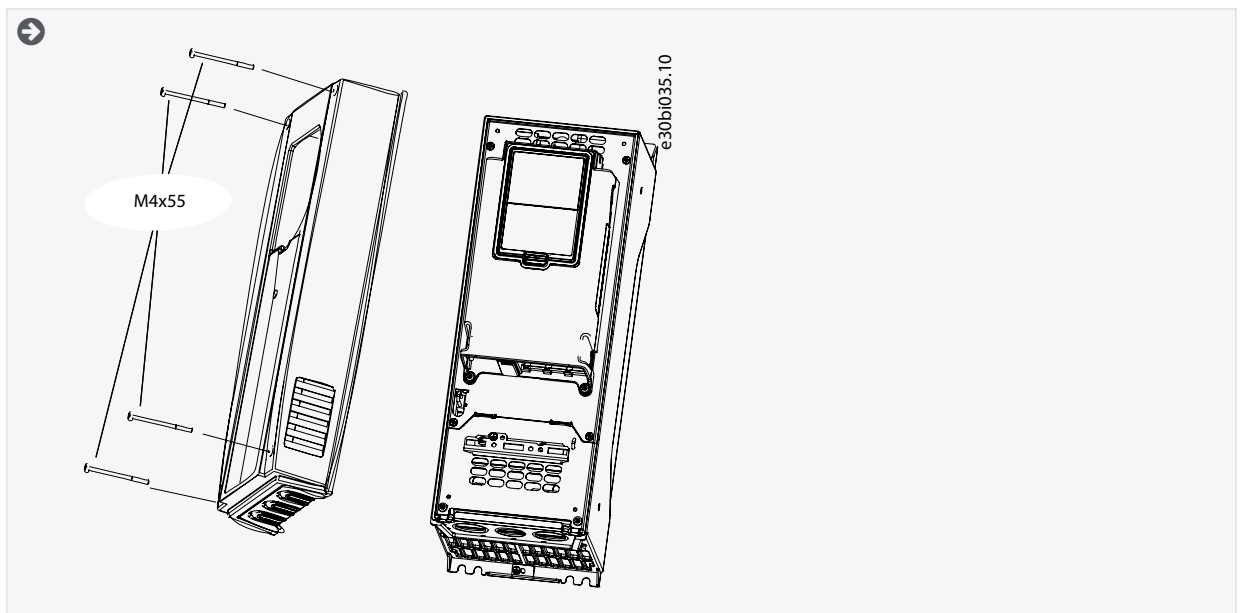

2. To get access to the option board slots, open the cover of the control unit.

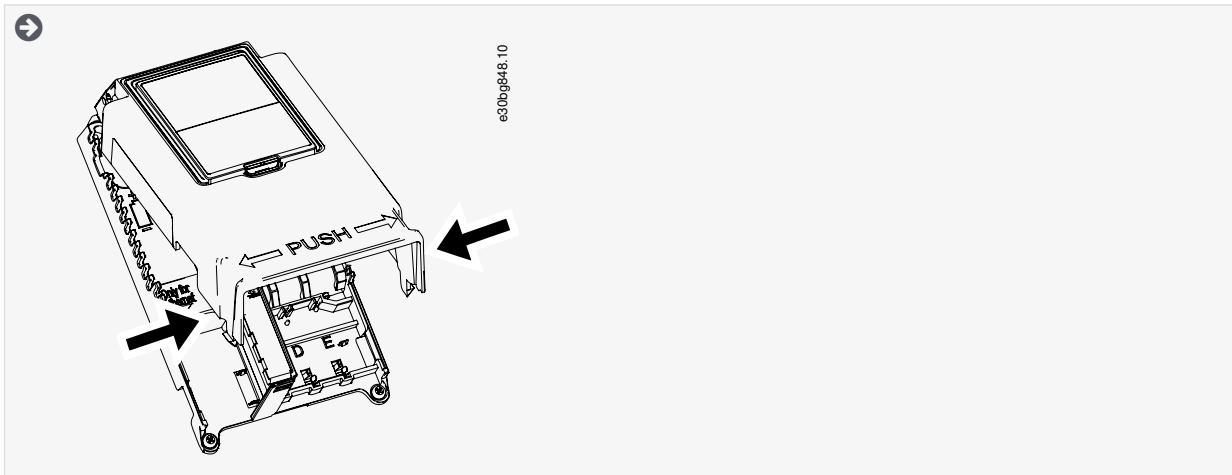

3. When installing option boards with D9 connector (OPTE5, OPTC5, OPTE8, OPTC8), replace the grounding bracket.
 - a. Remove the long grounding bracket installed in factory. It is mounted with two screws.
 - b. Install the short grounding bracket delivered with the option board. Use the screws removed in step a.

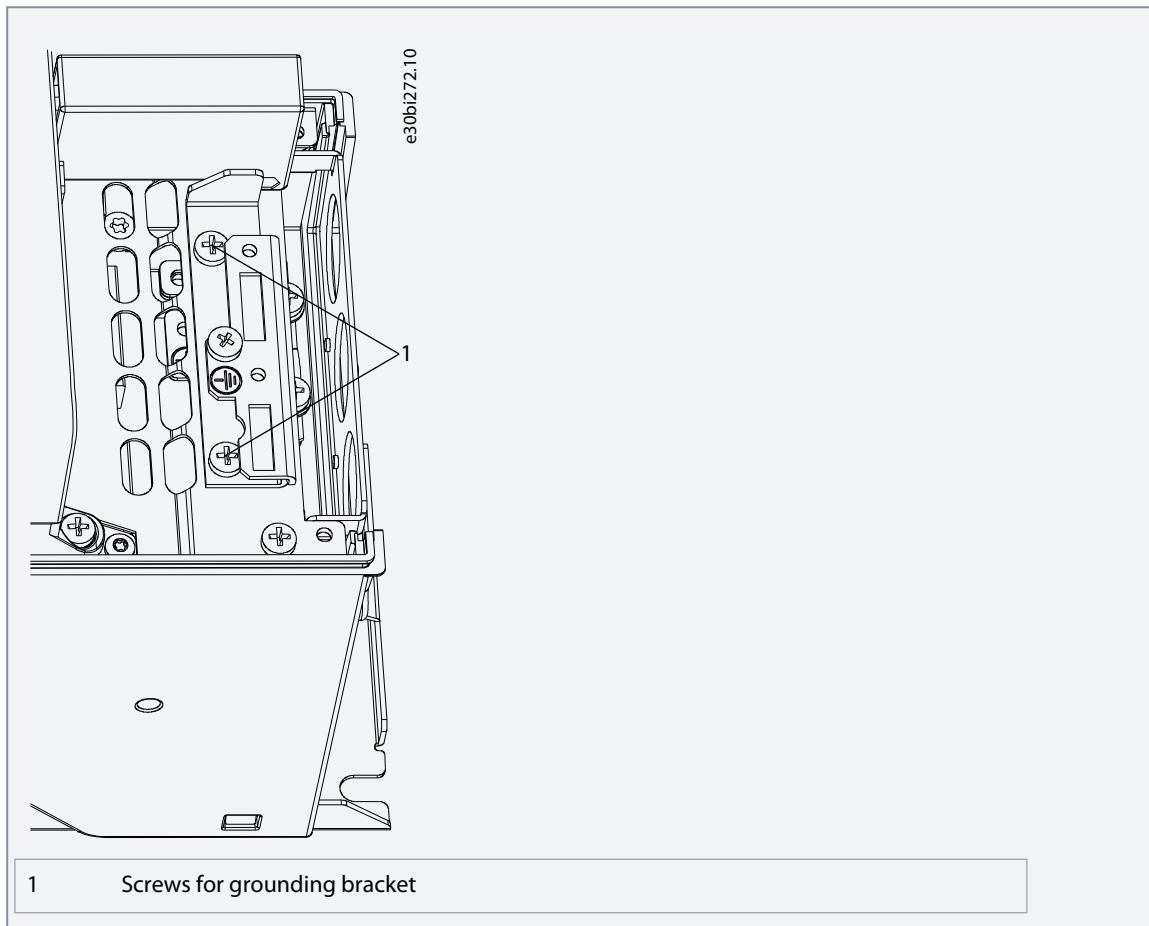

4. Install the option board into the slot D or E. Installation of option board into an in correct slot has been physically prevented. Do not use force.

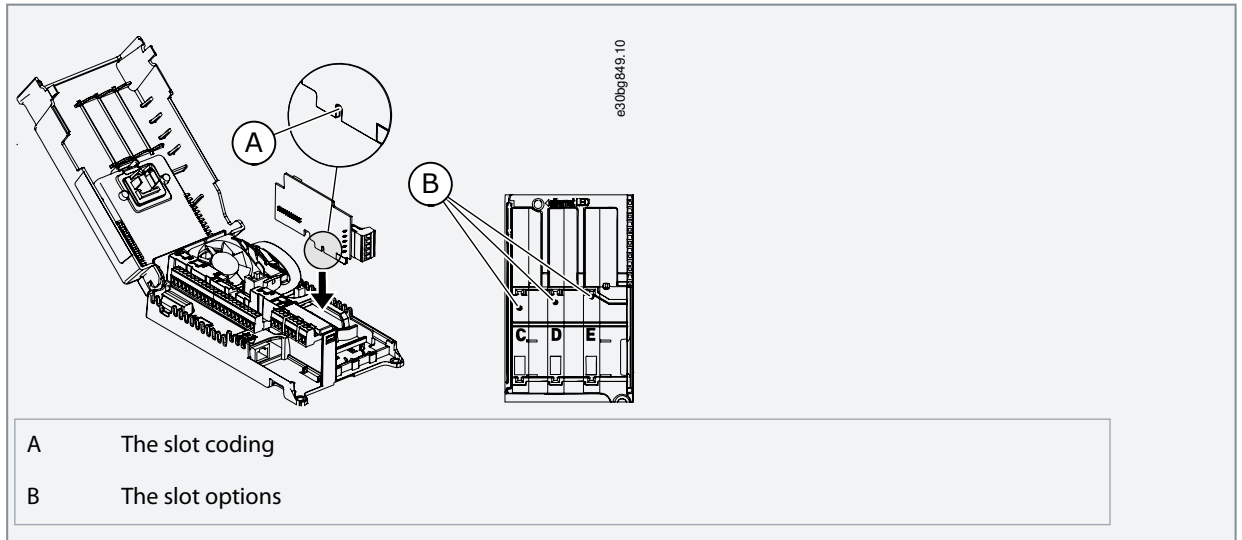

5. Close the cover of the control unit.
6. In IP21, cut free the opening on the cover of the AC drive for the fieldbus cable.
In IP54, cut a hole in a grommet and move the cable through it.

Make the connection tight. In internal fieldbus, make the opening on the left side. When installing into the slot D or E, make the opening on the right side.

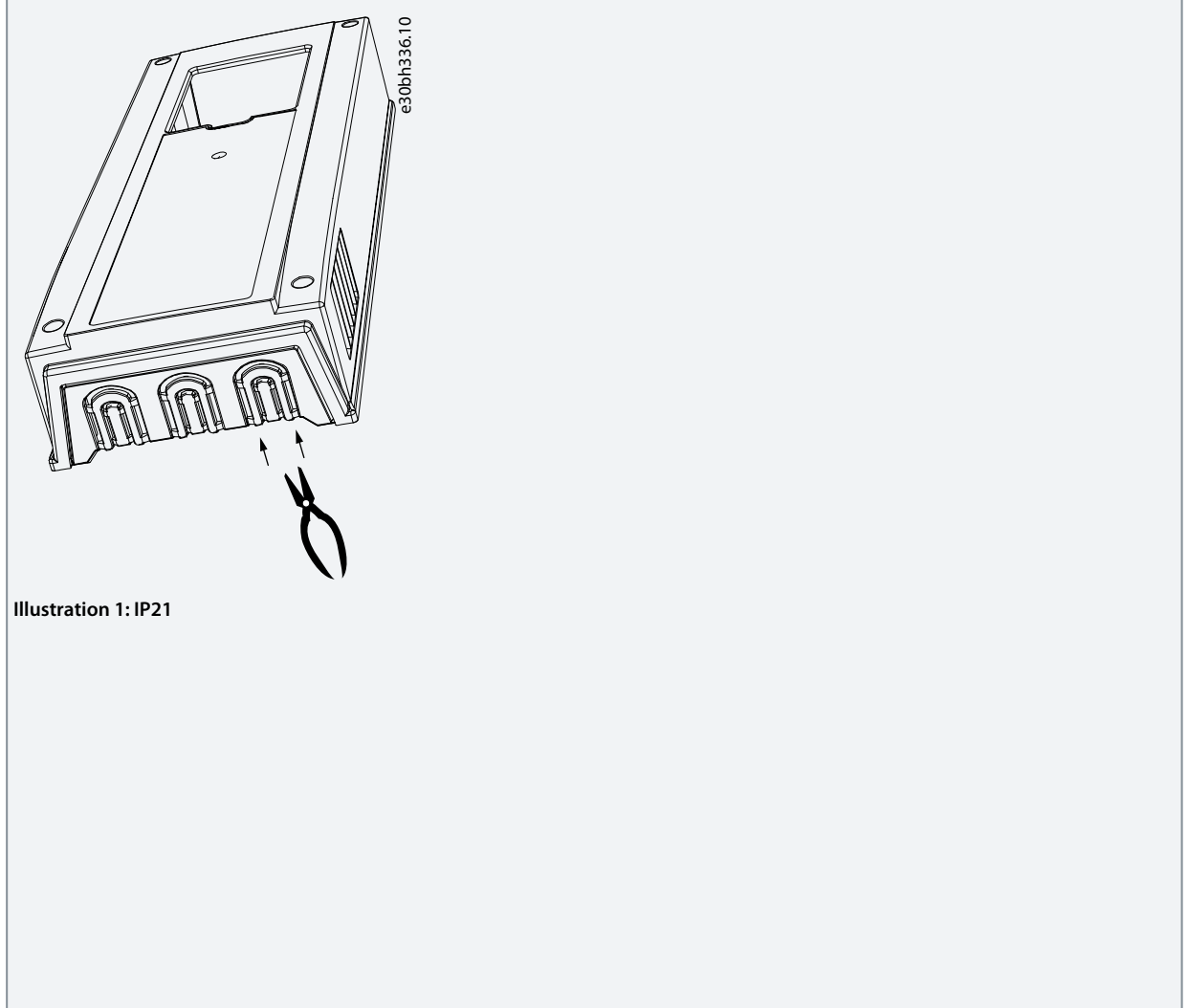

Illustration 1: IP21

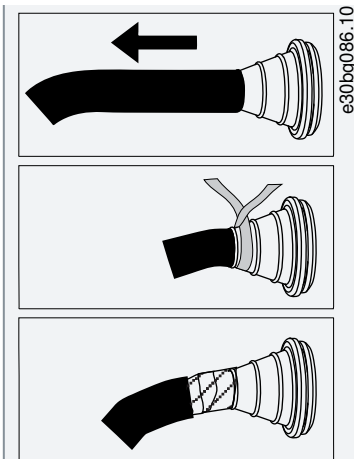
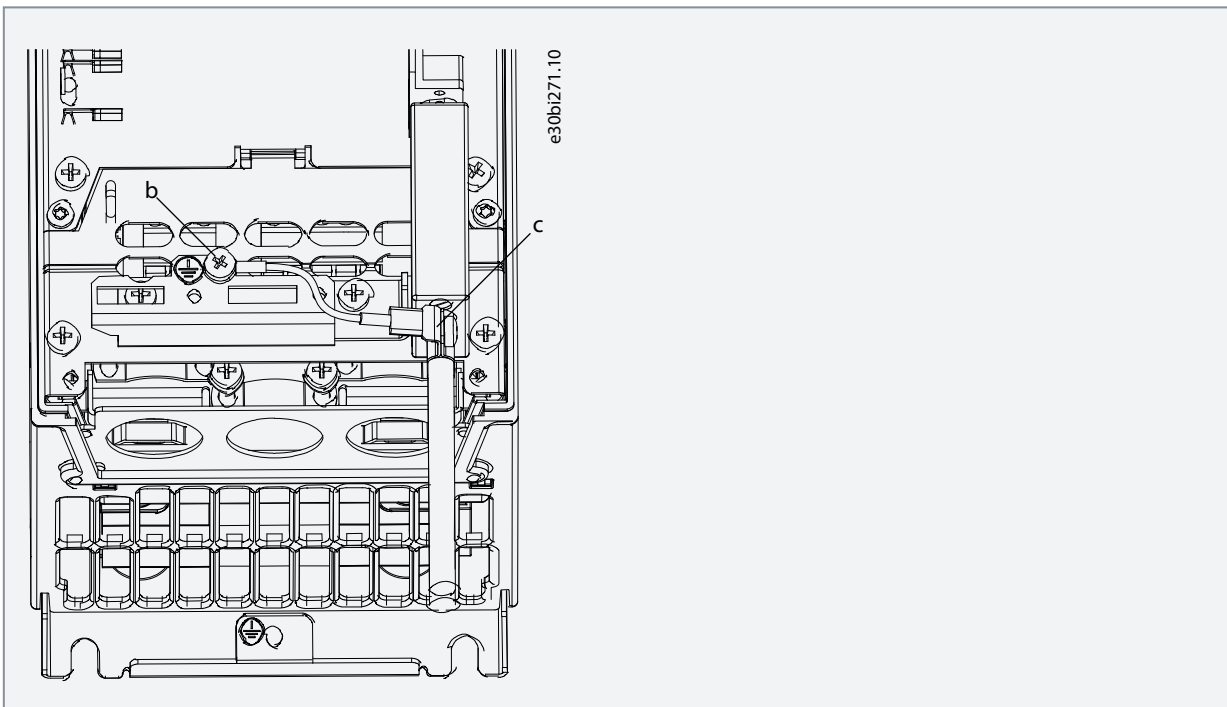

Illustration 2: IP55

7. Install the fieldbus and other cables. See more information in section Cabling. When installing option boards with D9 connector, use a separate grounding cable for grounding.
 - a. To make a 360° grounding, strip the cables connected to the D9 connector and install the grounding cable connector around the stripped part of the cables.
 - b. Attach the cable shoe to the short grounding bracket at the other end of the grounding cable with a screw.
 - c. When the D9 connector is mounted to option board, install the grounding cable to the grounding cable connector mounted around the stripped cable in step a.

With D9 connectors on both slots D and E:

- For slot D, mount first the option board and route the grounding cable below all cables. Make sure that the cable connector is facing down.
- For slot E, route the option board grounding cable on top of the cables.



8. Close the cover of the AC drive.

9. Pull the fieldbus cable to the side. Move the fieldbus cables away from the mains cable and the motor cable.

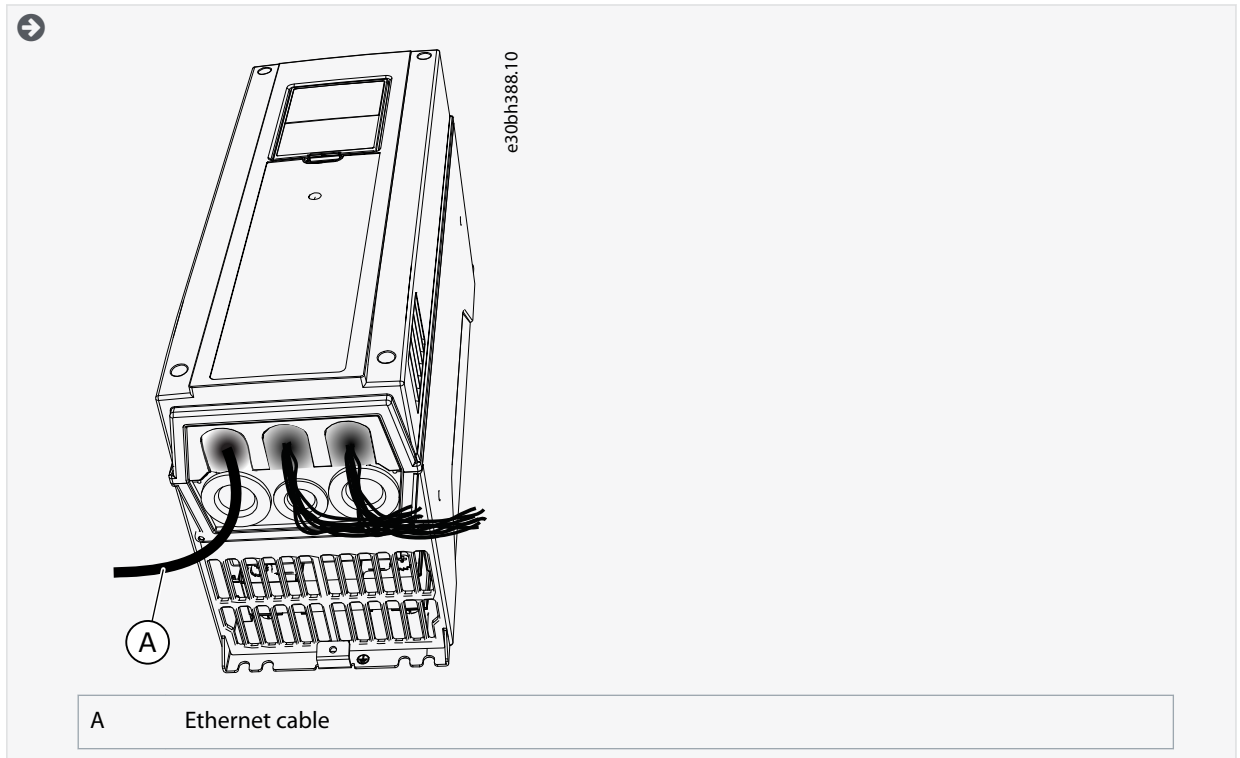

3.3 Installing Option Board in VACON® 100 X

This topic gives instructions for installing the option boards in VACON[®] 100 X, MM4–MM6.

Procedure

1. Open the cover of the AC drive.

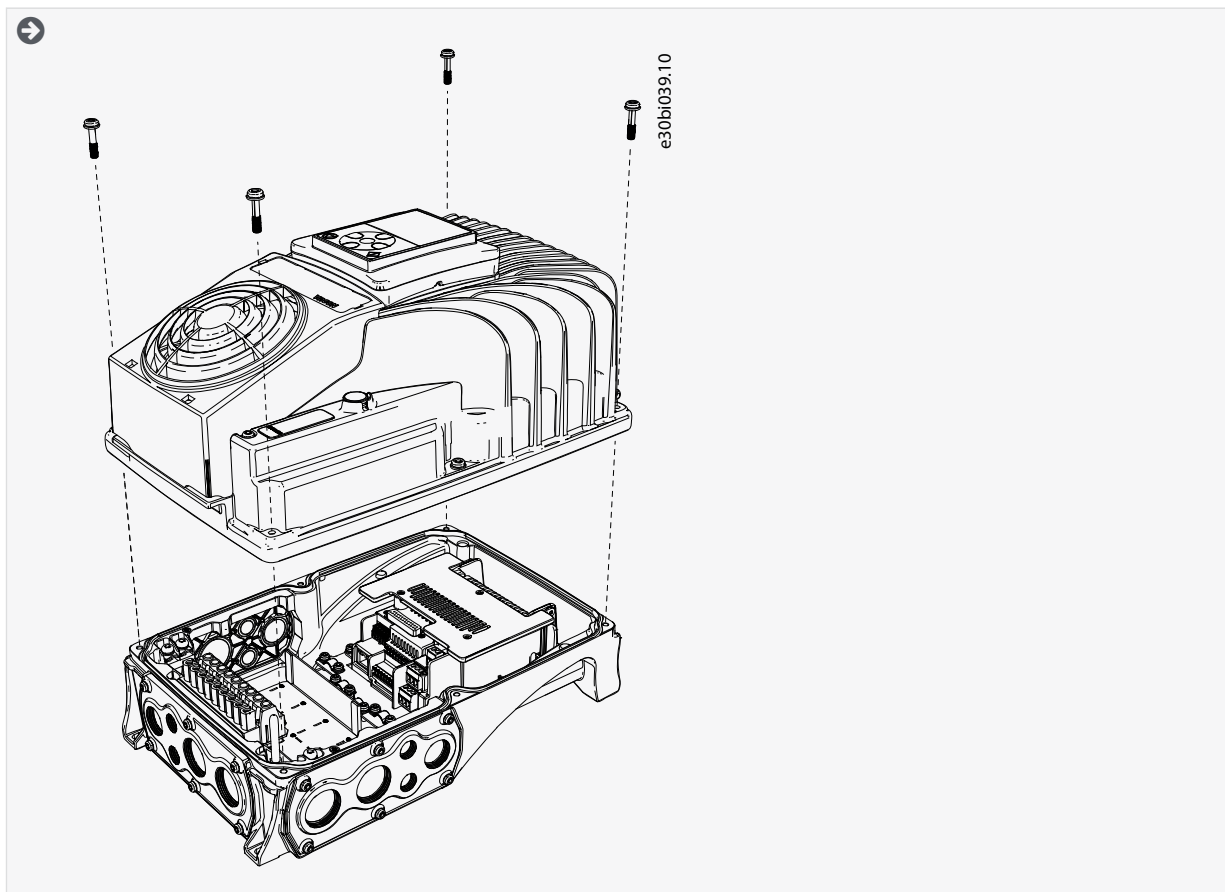

- To get access to the option board slots, remove the screws and open the cover of the control unit.

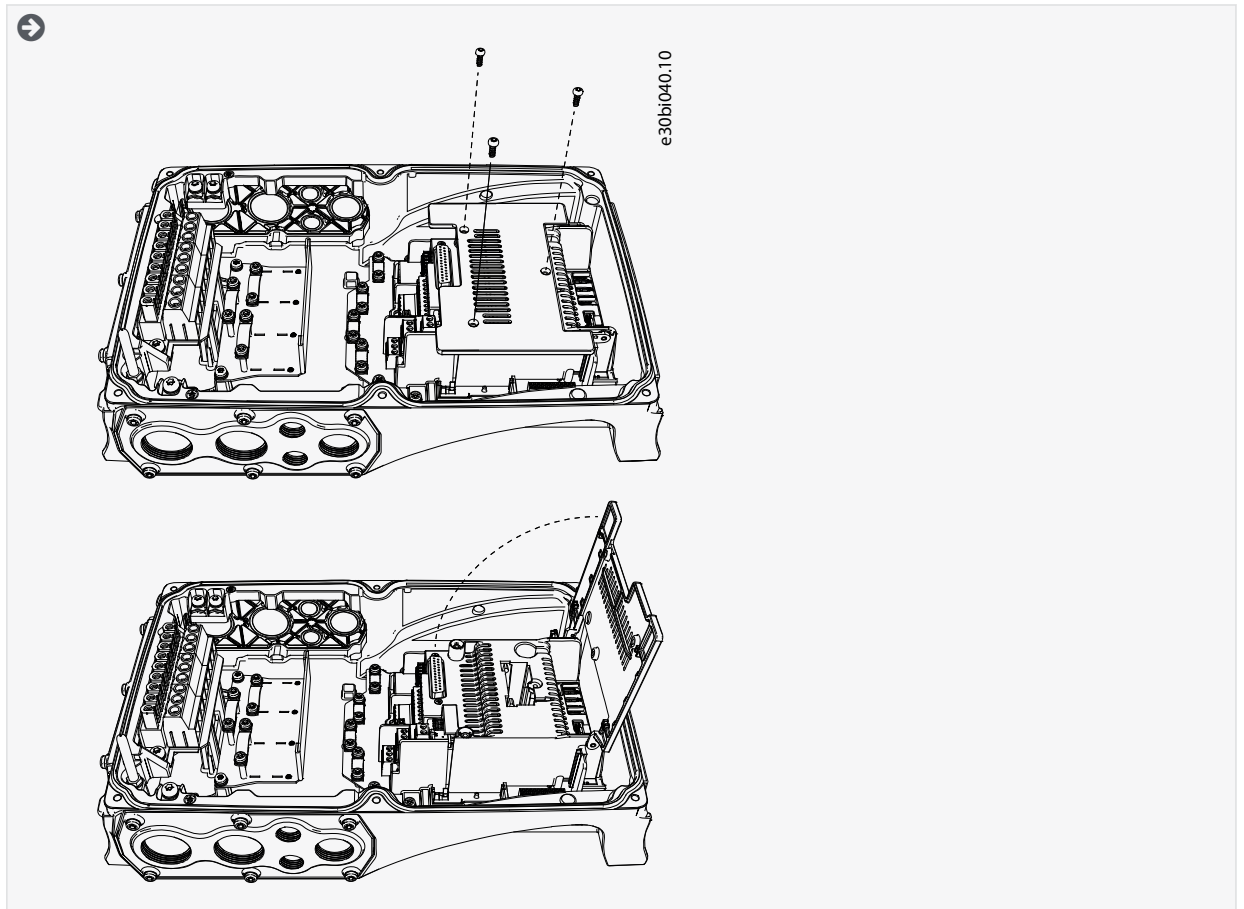

3. Install the option board into the slot D or E.

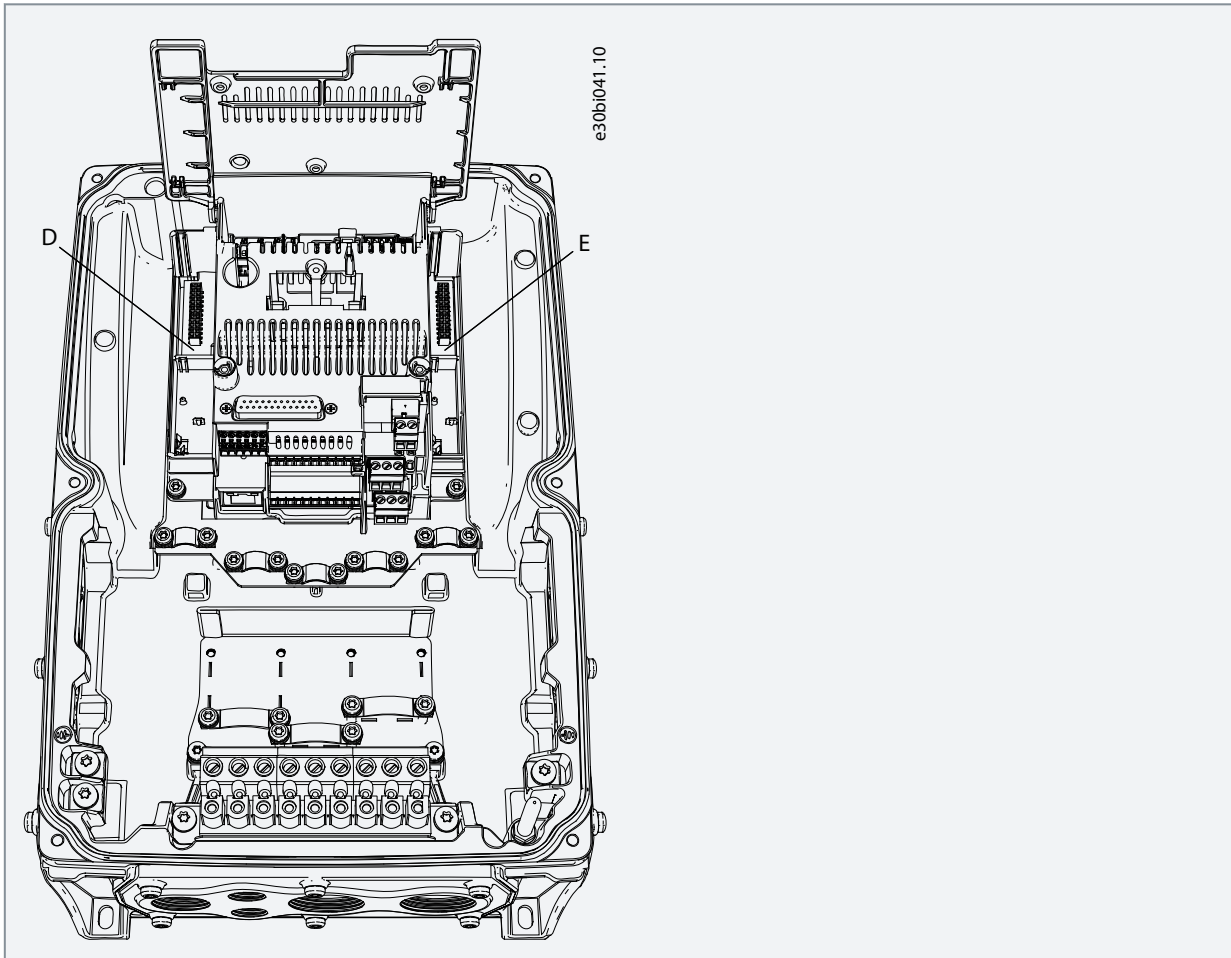

4. Close the option board cover.
5. Remove the cable entry plate. If the option board is installed in the slot D, use the cable entry plate on the right side. If the option board is installed in the slot E, use the cable entry plate on the left side.

NOTE! The cable entry plate at the bottom of the drive is used only for mains and motor cables.

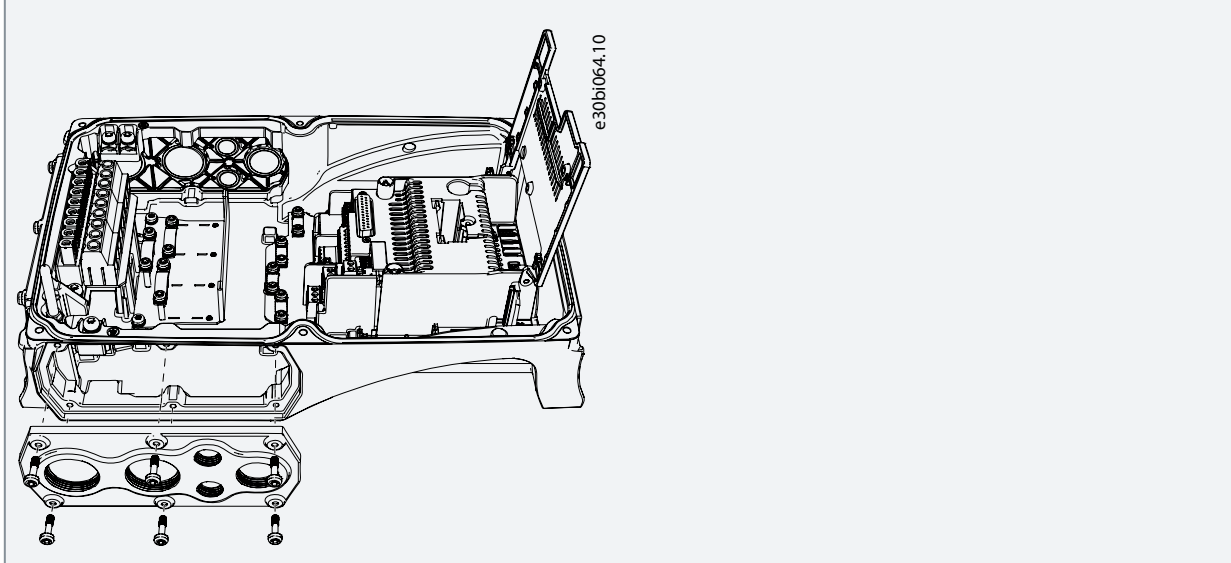

6. Open the necessary holes in the cable entry plate. Do not open the other holes. See the VACON[®] 100 X Installation Manual for the dimensions of the holes.

7. Attach a cable gland on the hole in the cable entry plate. Pull the fieldbus cable through the hole.

NOTE! The fieldbus cable must go through the correct cable entry plate to avoid going near the motor cable. Avoid small bend radius in the fieldbus cables. If the option board is installed in the slot D, use the cable entry plate on the right side. If the option board is installed in the slot E, use the cable entry plate on the left side.

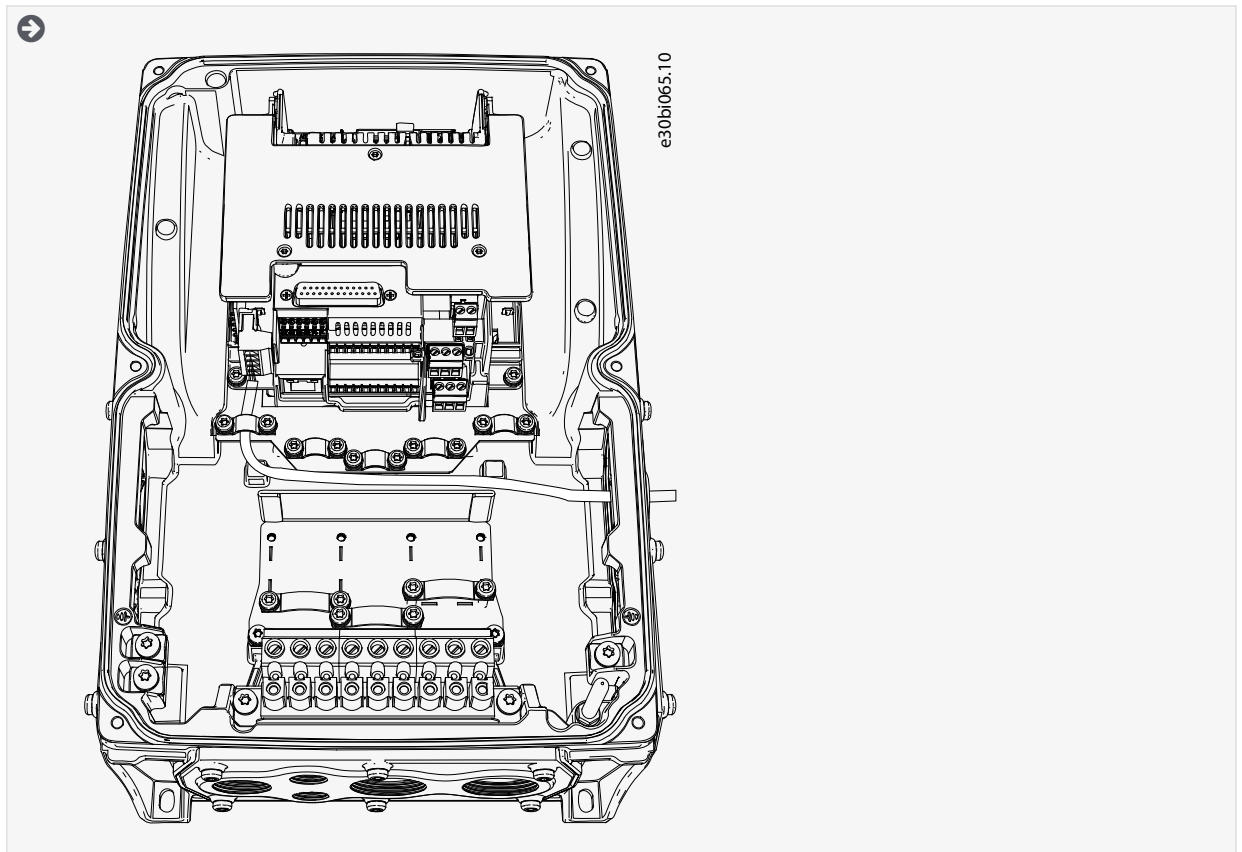

8. Put back the cable entry plate.
9. Close the cover of the AC drive.

3.4 Installing Option Board in VACON® 20

3.4.1 Installing Option Board in VACON® 20, MI1–MI3

This topic gives instructions for installing the option boards in VACON® 20, MI1–MI3.

For option board installation, a separate option board mounting kit is required.

Procedure

1. Remove the cable connector lid from the AC drive.

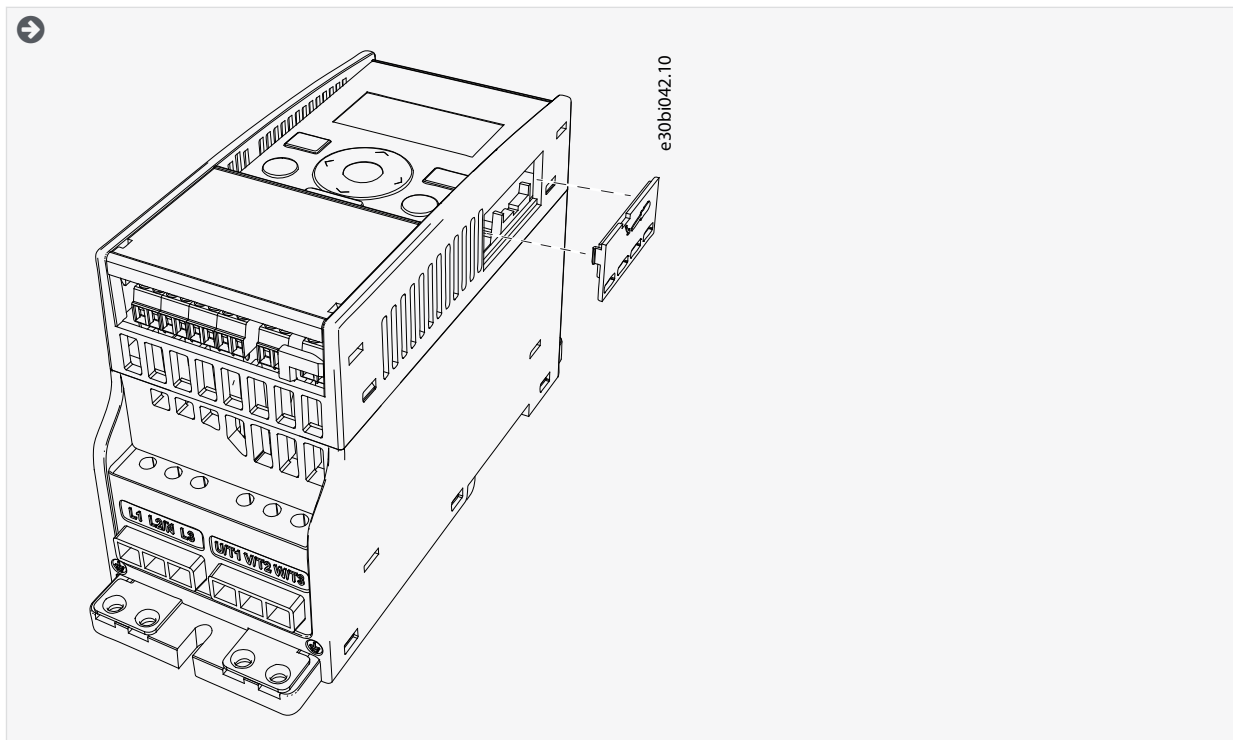

2. Select a correct grounding plate and attach it to the option board mounting frame. The grounding plate is marked with the supported enclosure size.

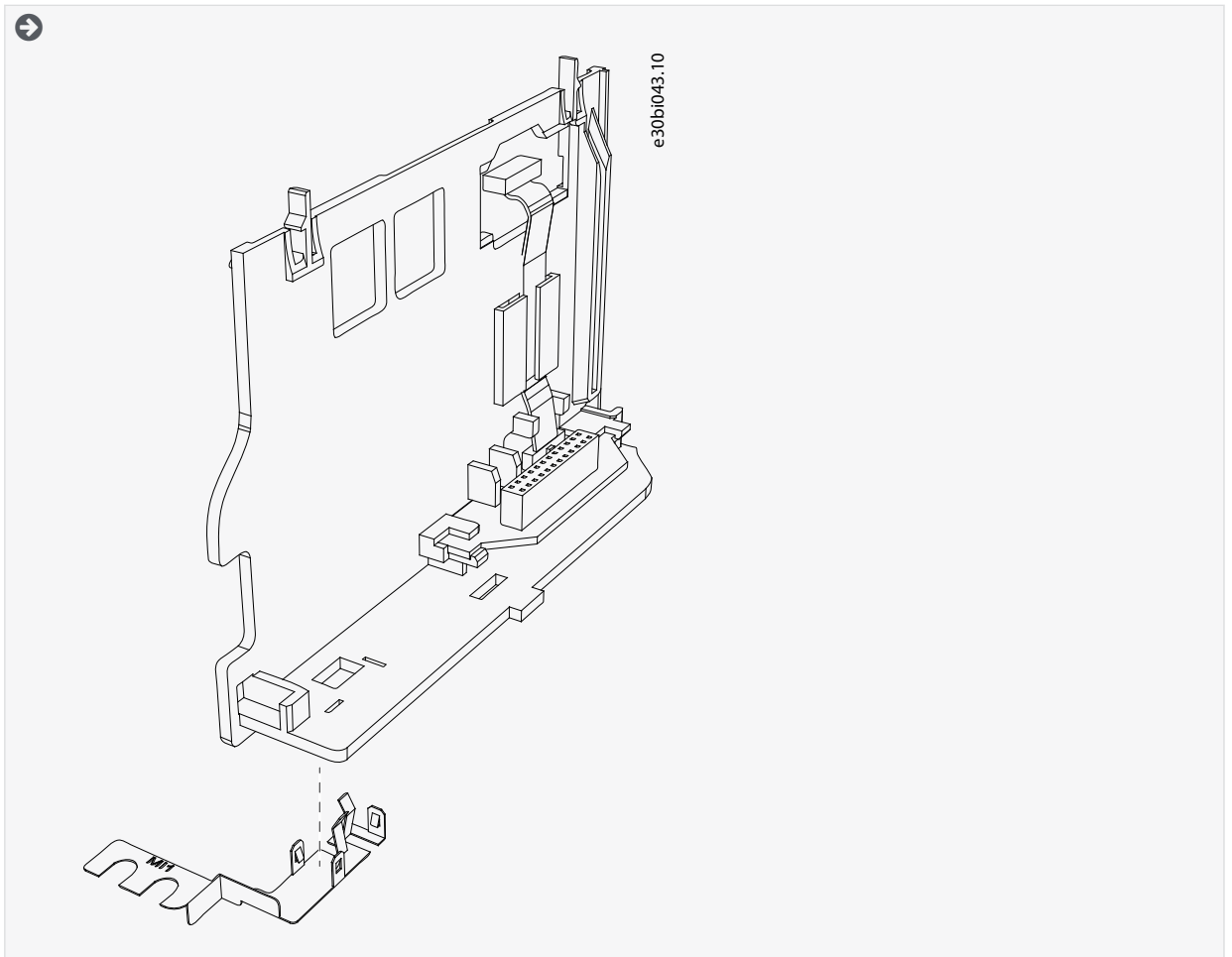

3. Attach the option board mounting frame to the AC drive.

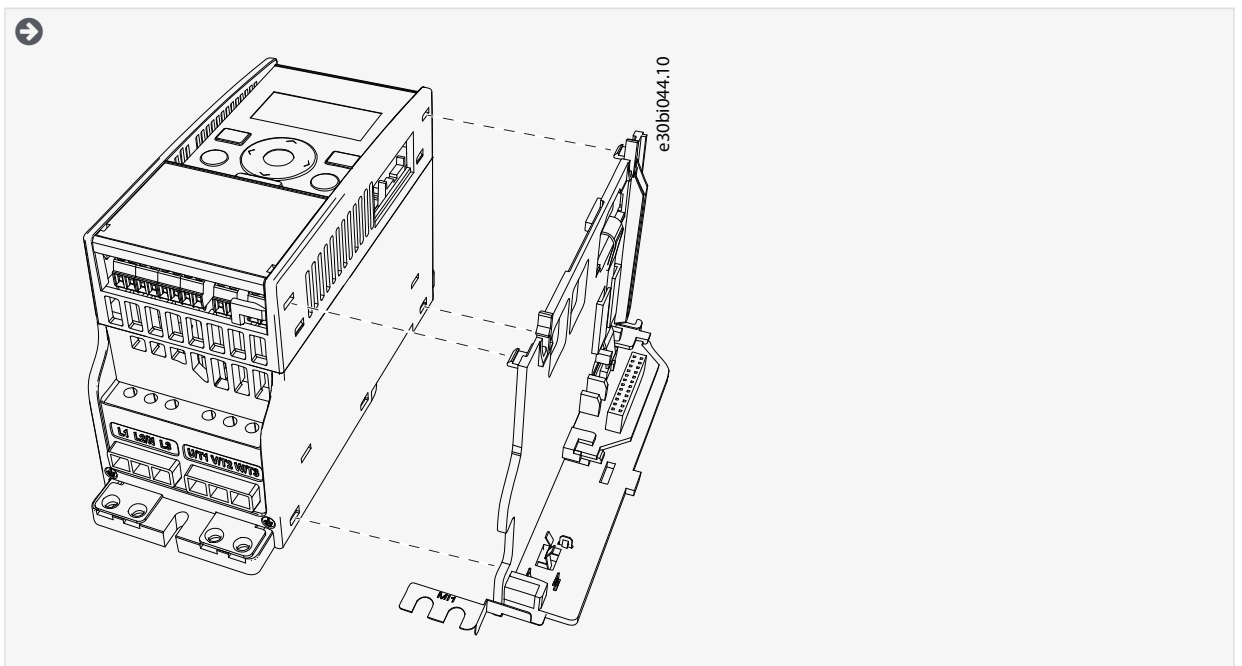

4. Connect the flat cable from the option board mounting frame to the AC drive.

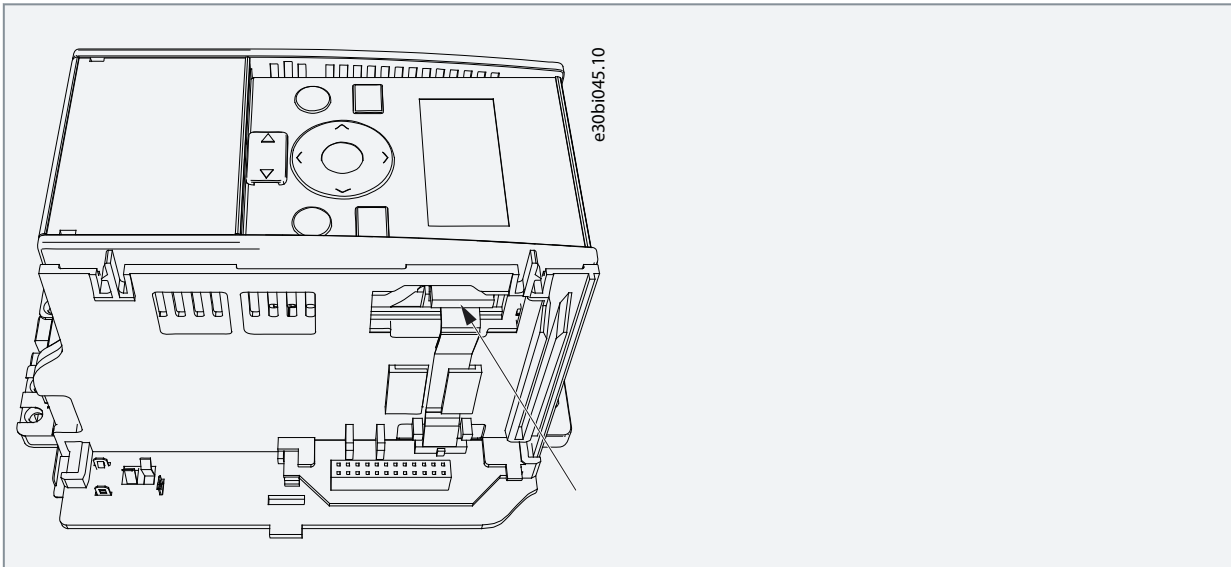

5. If a strain relief is necessary for the cable, attach it.

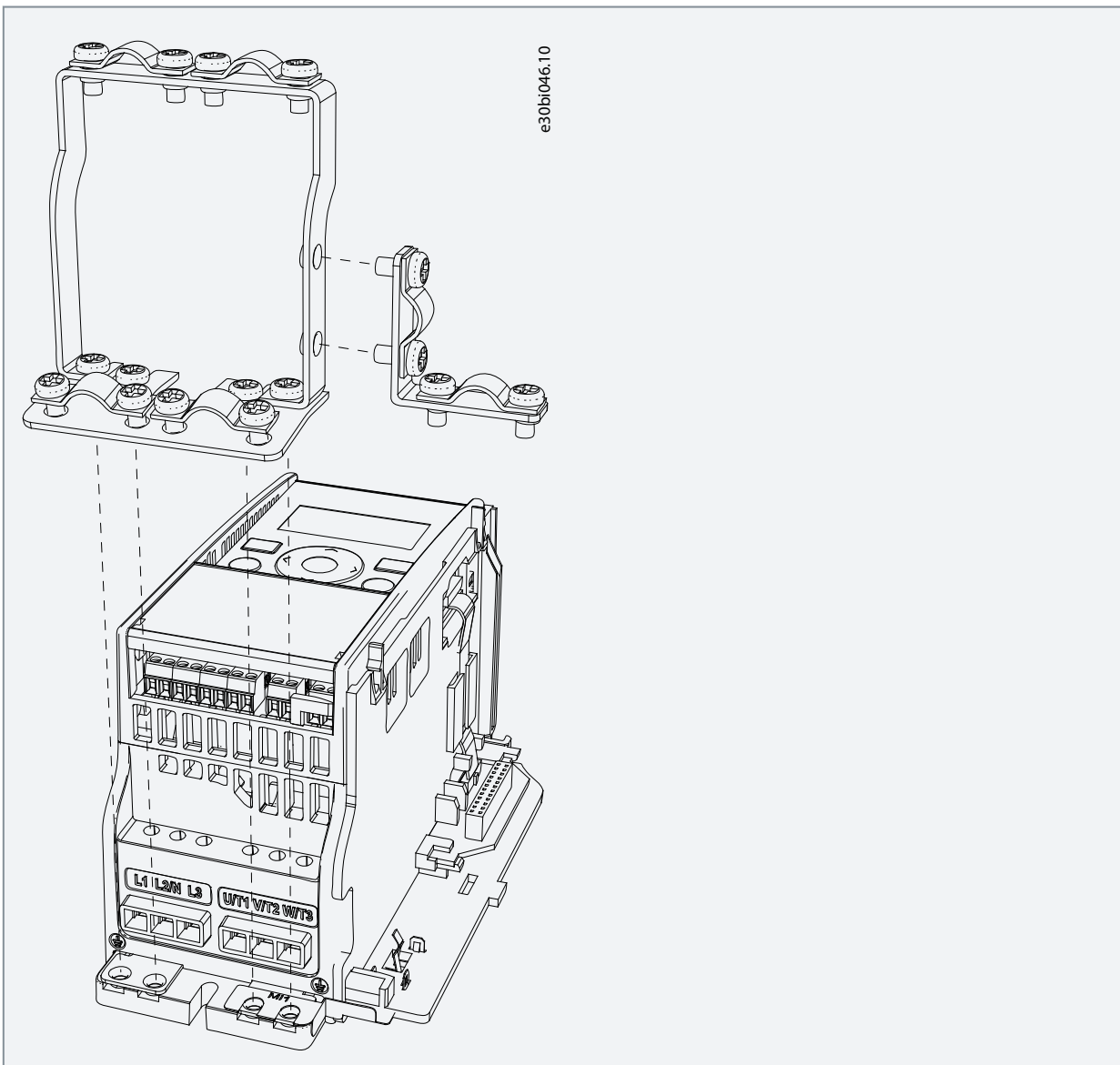

6. Install the option board to the option board holder. Make sure that the option board is securely fastened.

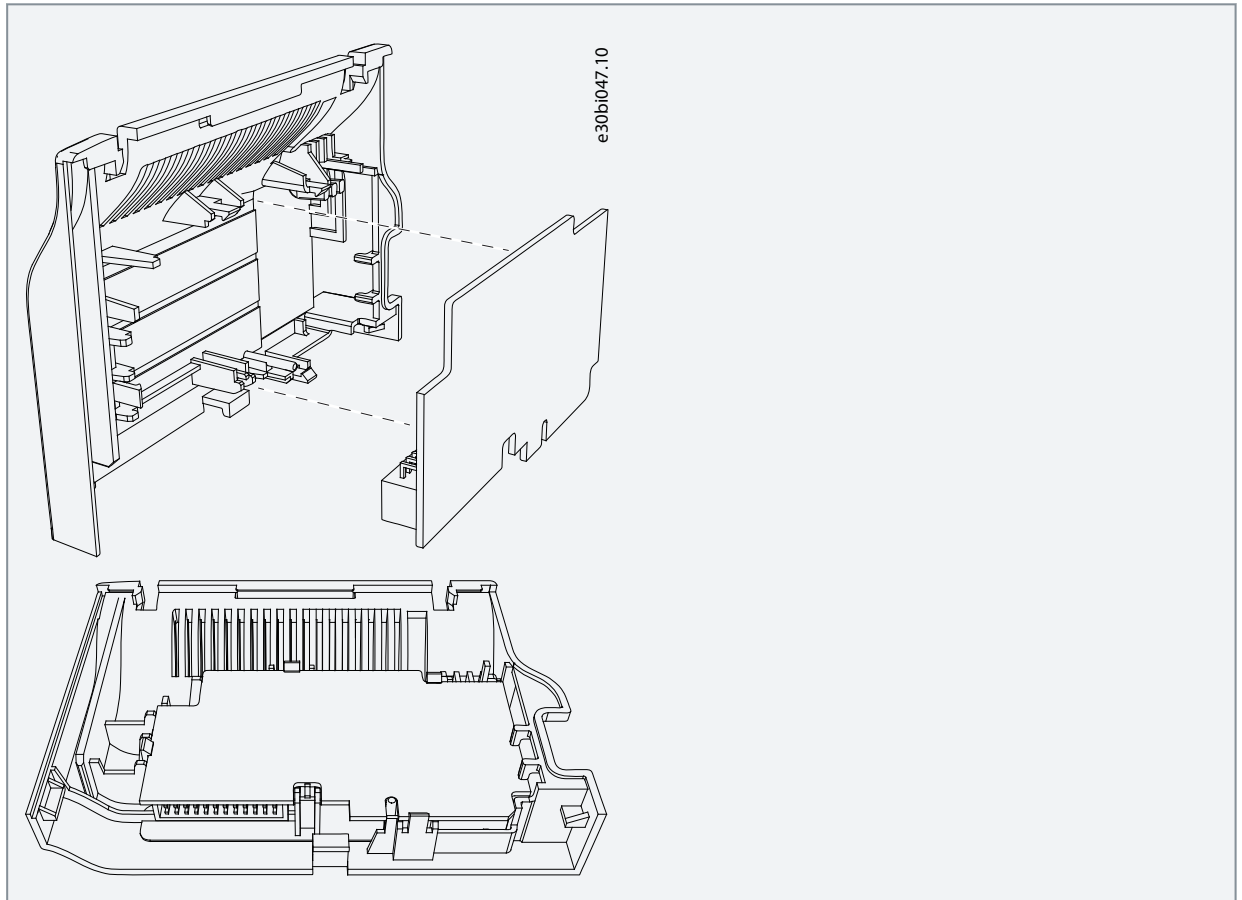

7. Cut free a sufficiently wide opening for the option board connector.

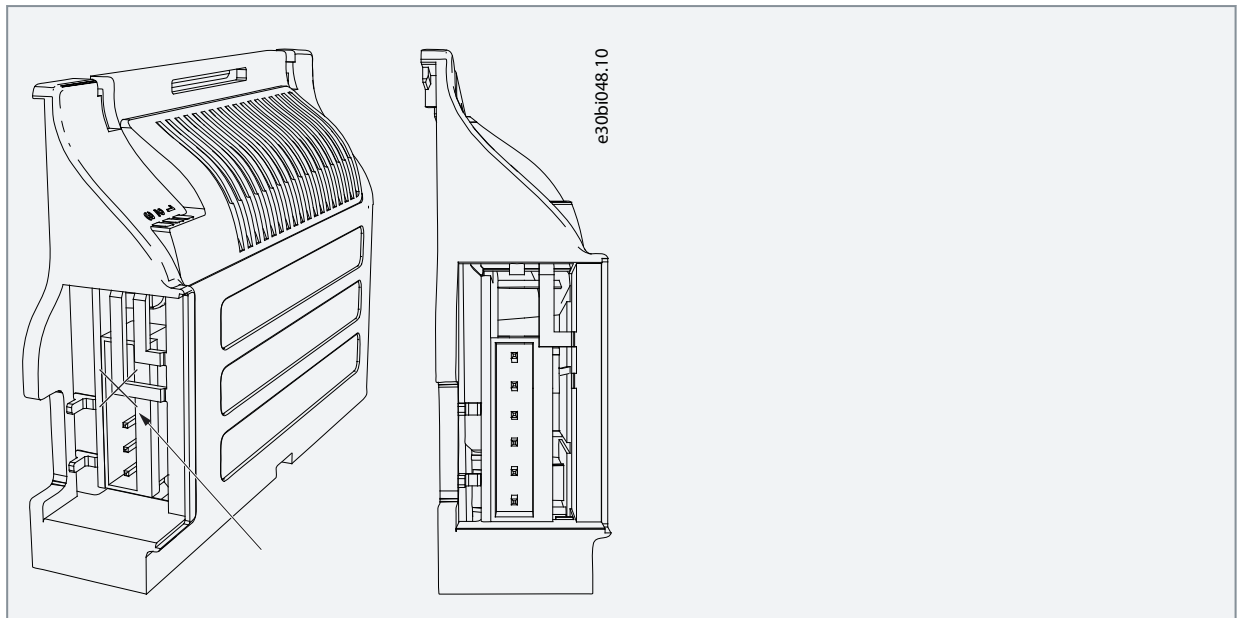

- Attach the option board cover to the drive. If strain relief is necessary, attach the strain relief cable clamp with screws.

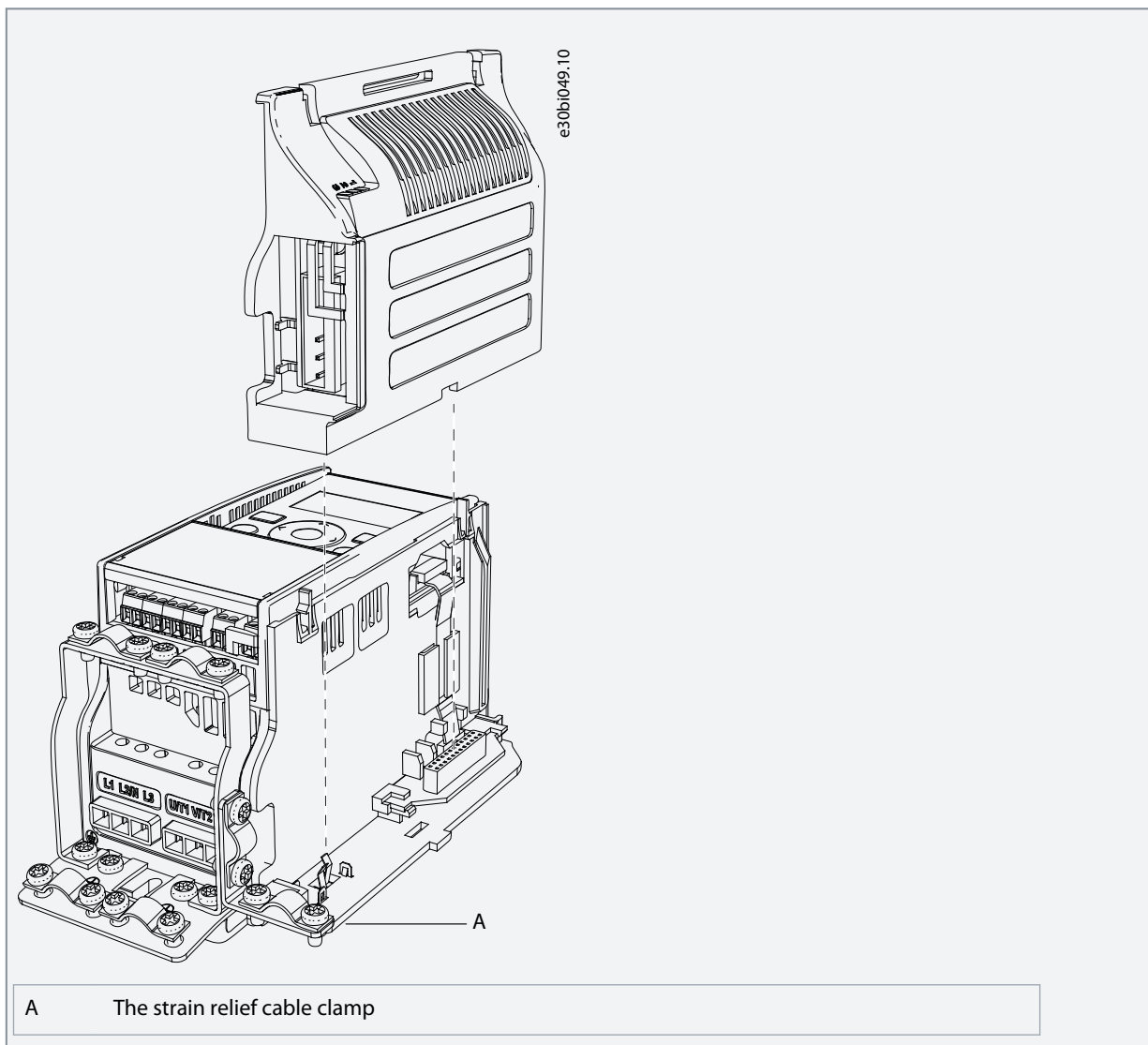

3.4.2 Installing Option Board in VACON® 20, MI4–MI5

This topic gives instructions for installing the option boards in VACON® 20, MI4–MI5.

Procedure

1. In MI4, open the cover of the AC drive. In MI5, open the cover of the AC drive and release the fan connector.

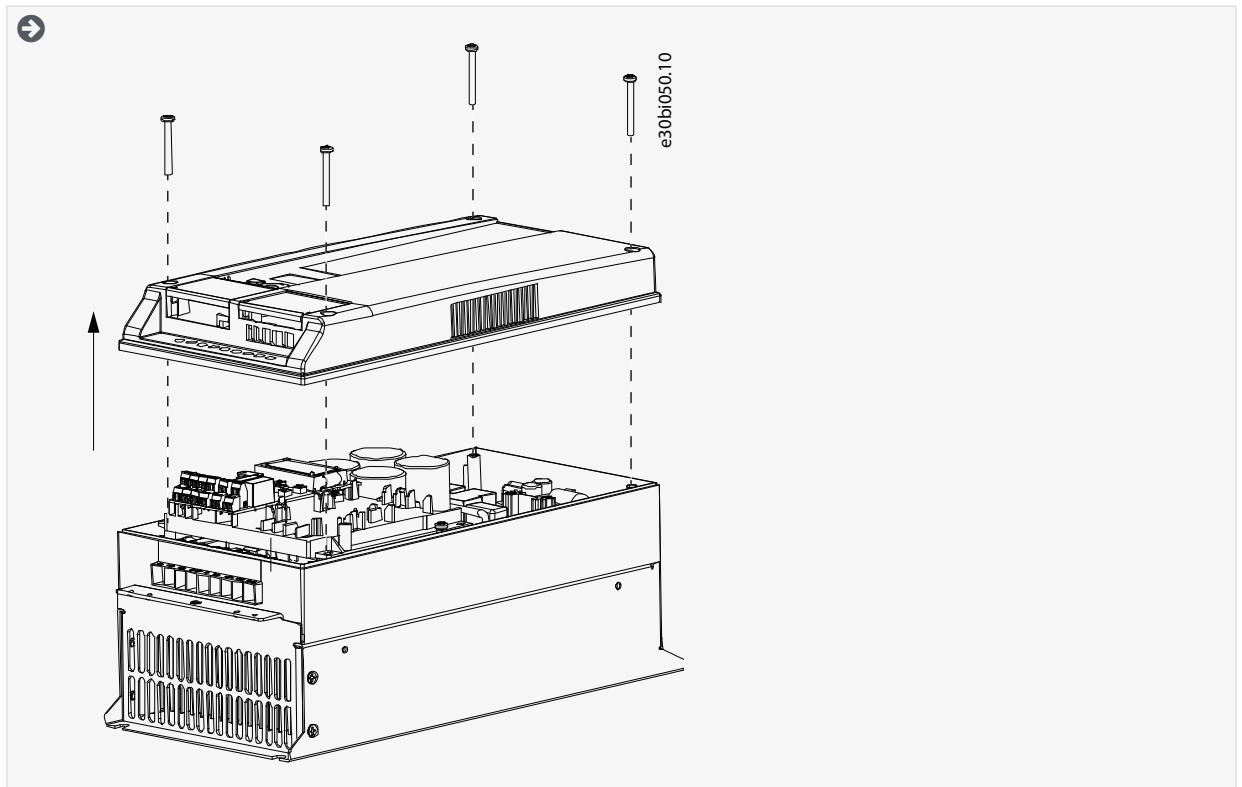

2. Attach the option board support.

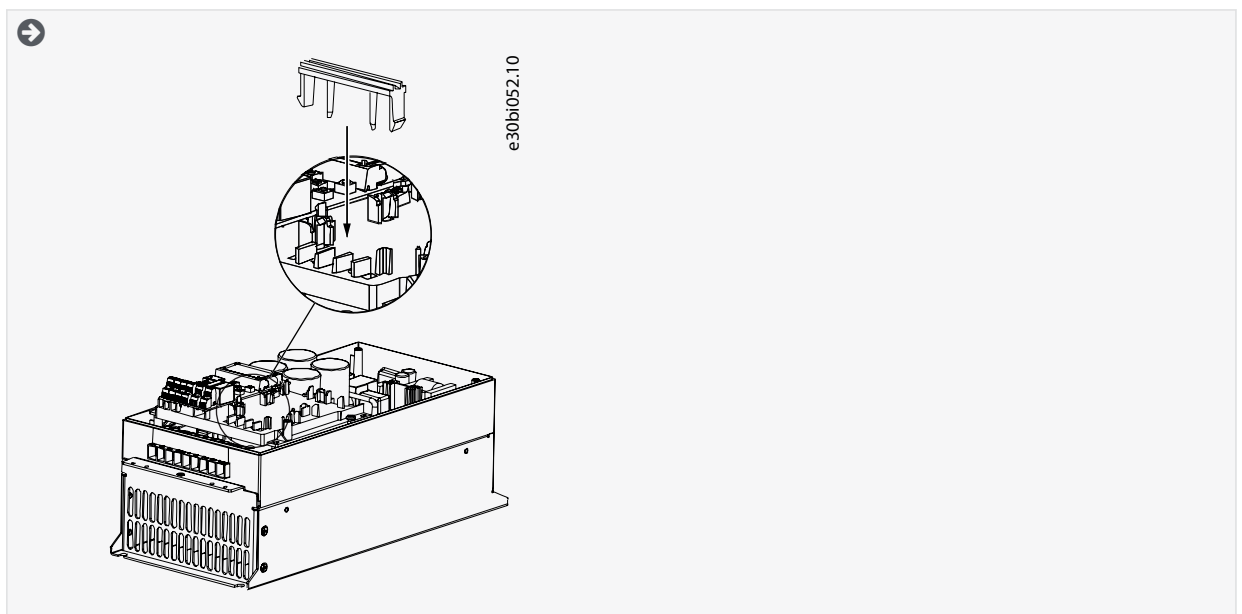

3. Connect the flex cable to the connector PCB.

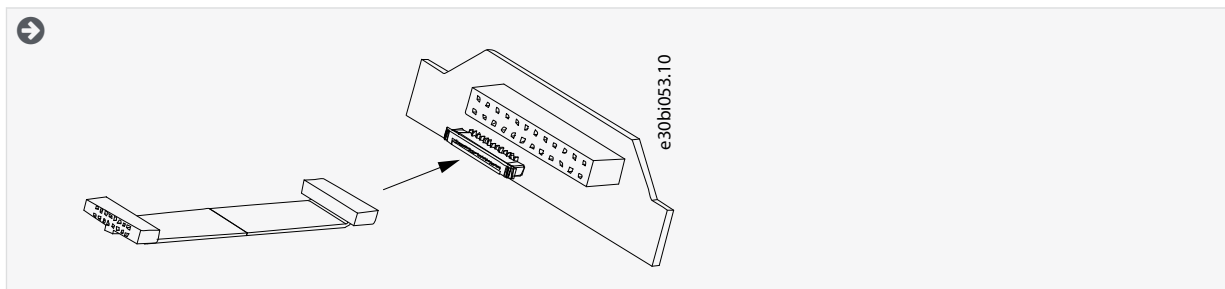

4. Attach the option board to the connector PCB.

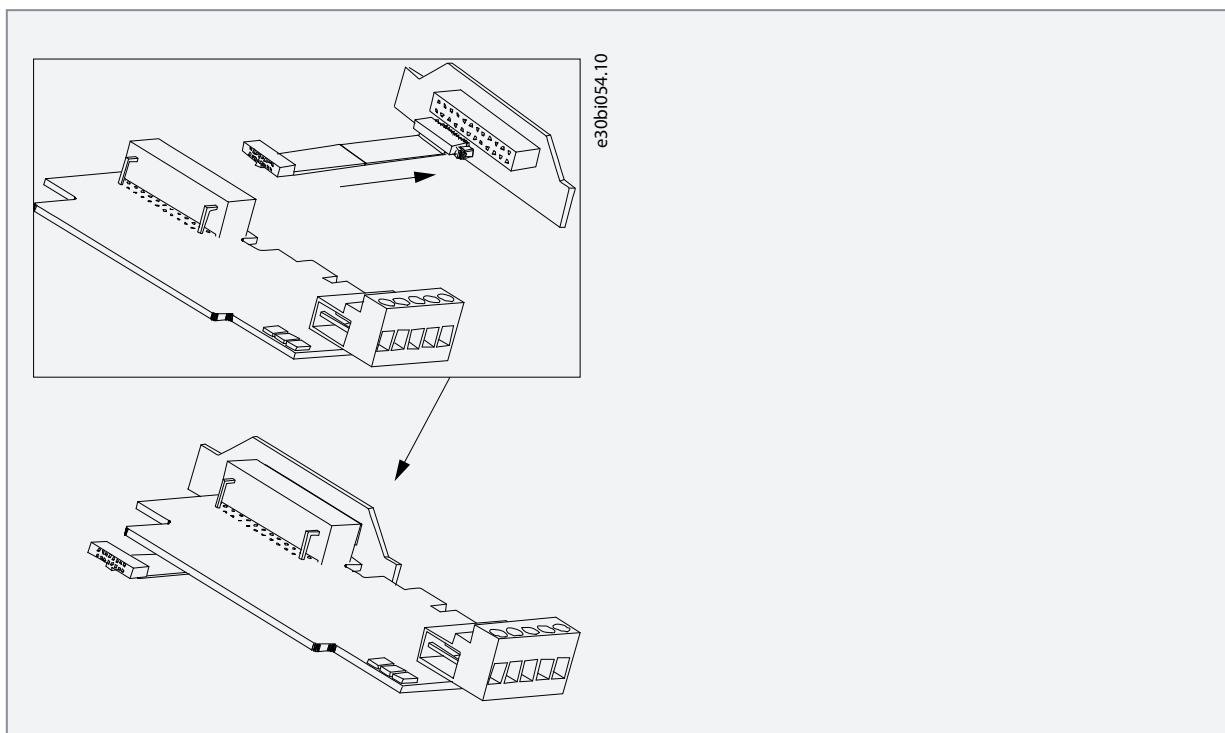

- Attach the option board assembly to the AC drive and connect the flex cable.

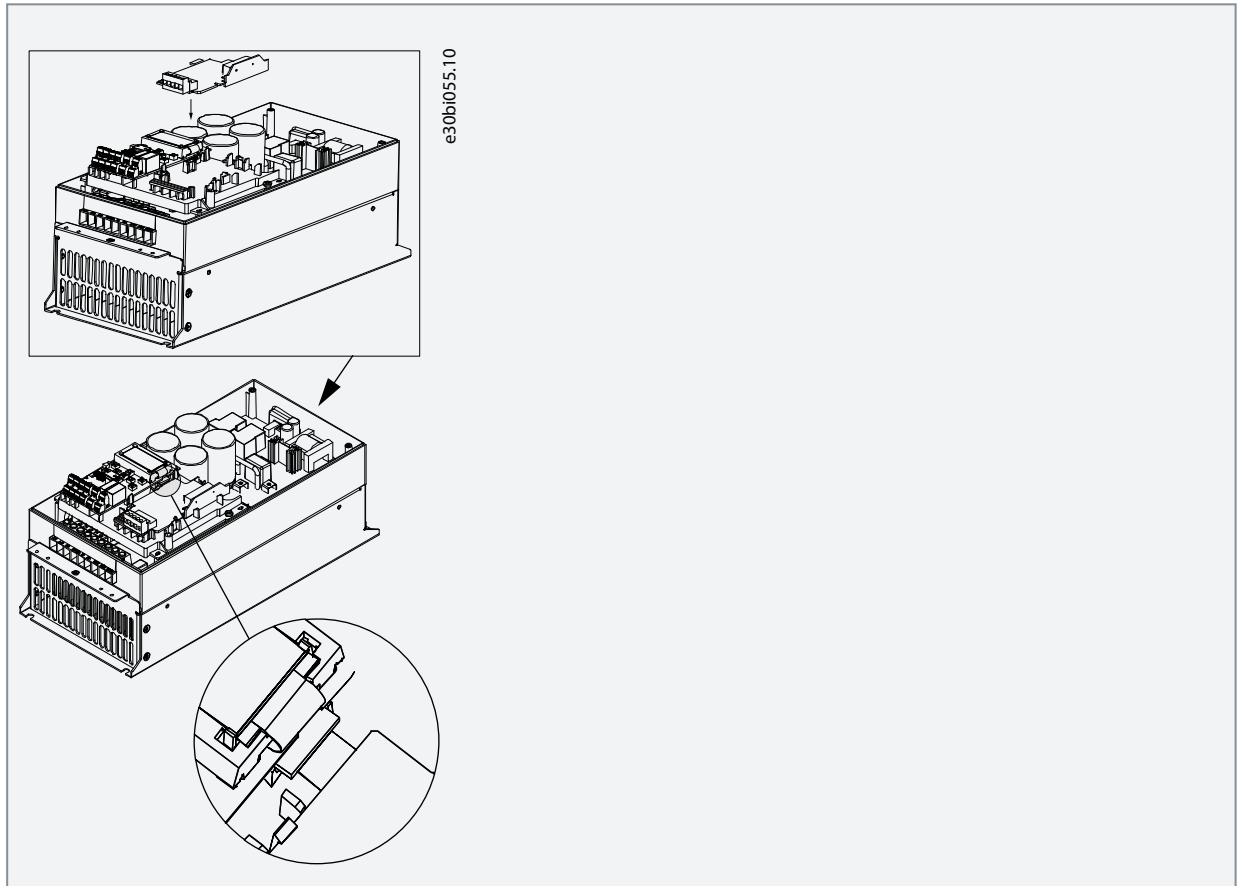

- Attach a correct grounding plate to the AC drive. The grounding plate is marked with the supported enclosure size.

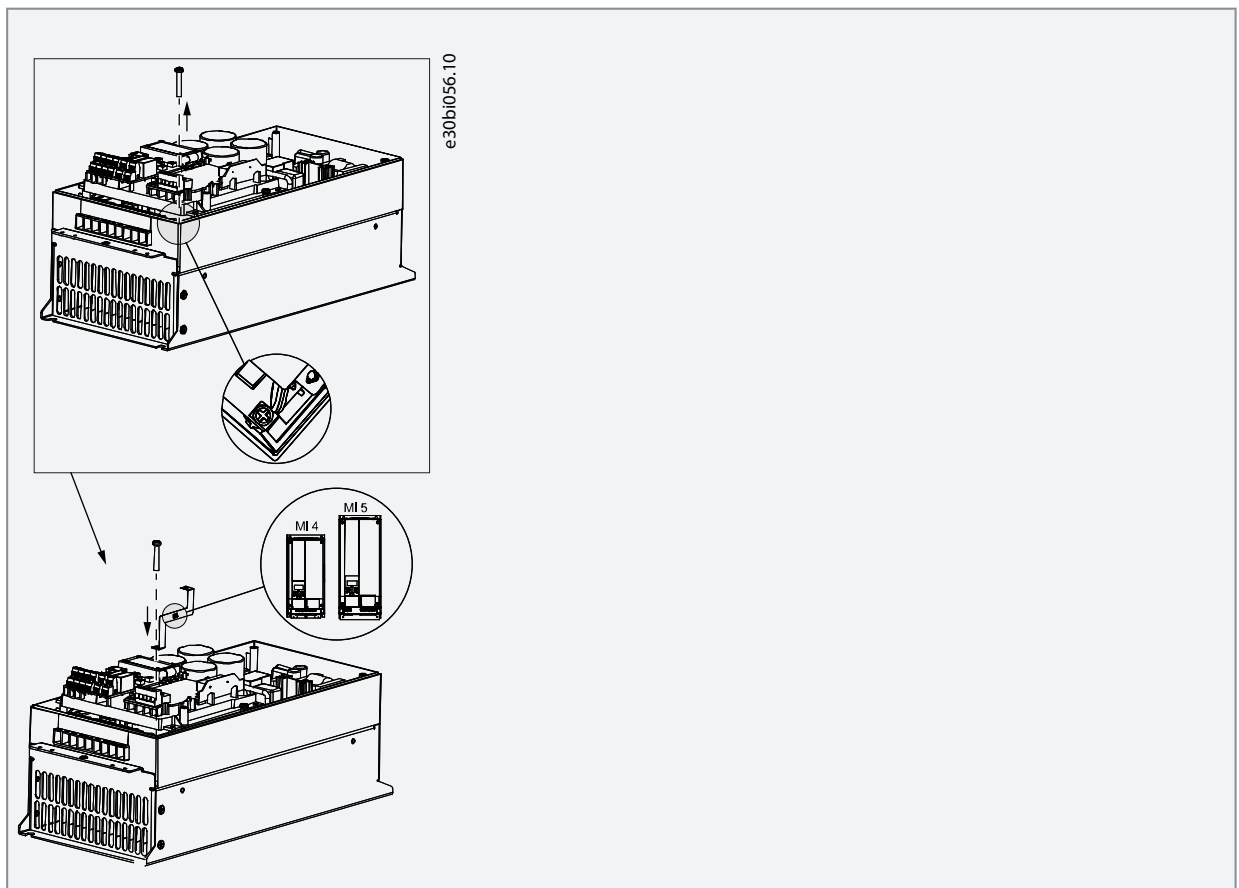

- Put a clamp on top of the grounding plate on both sides of the option board.

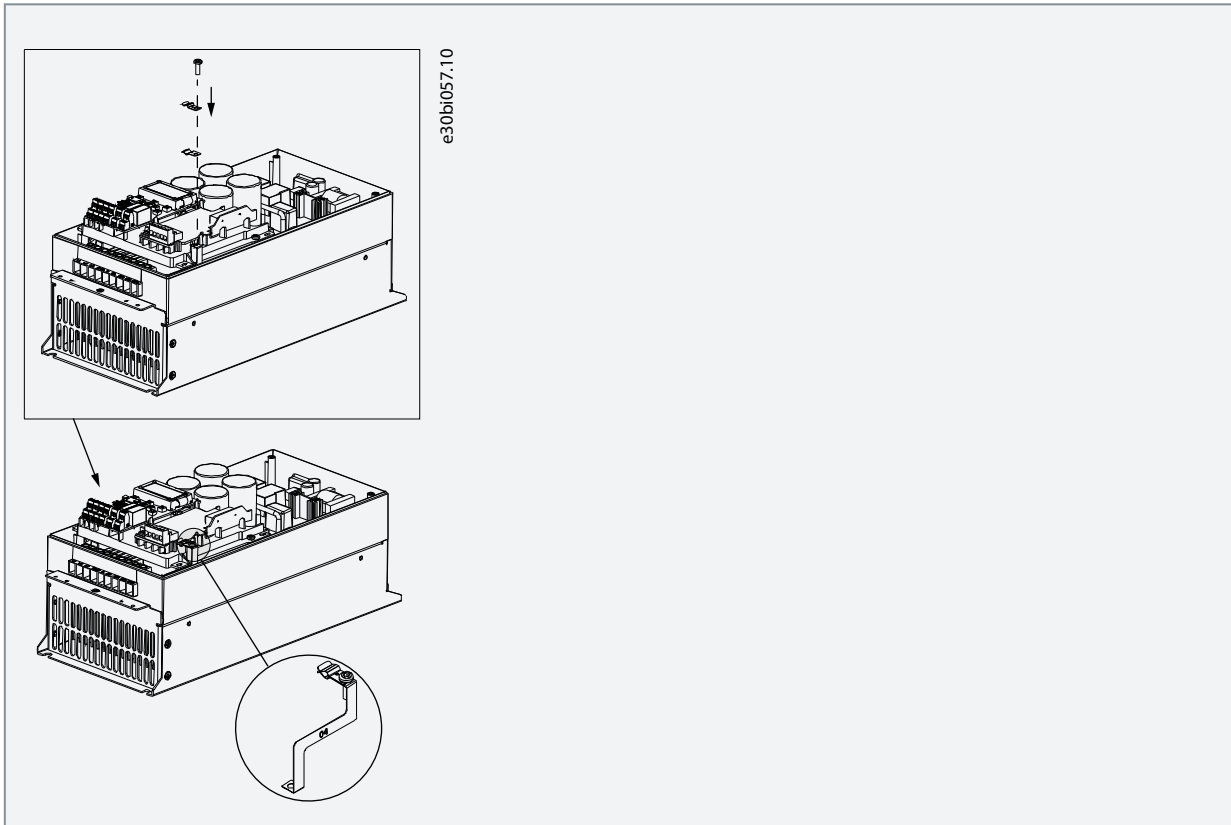

- In MI4, close the cover of the drive. In MI5, attach the fan connector and close the cover of the AC drive.

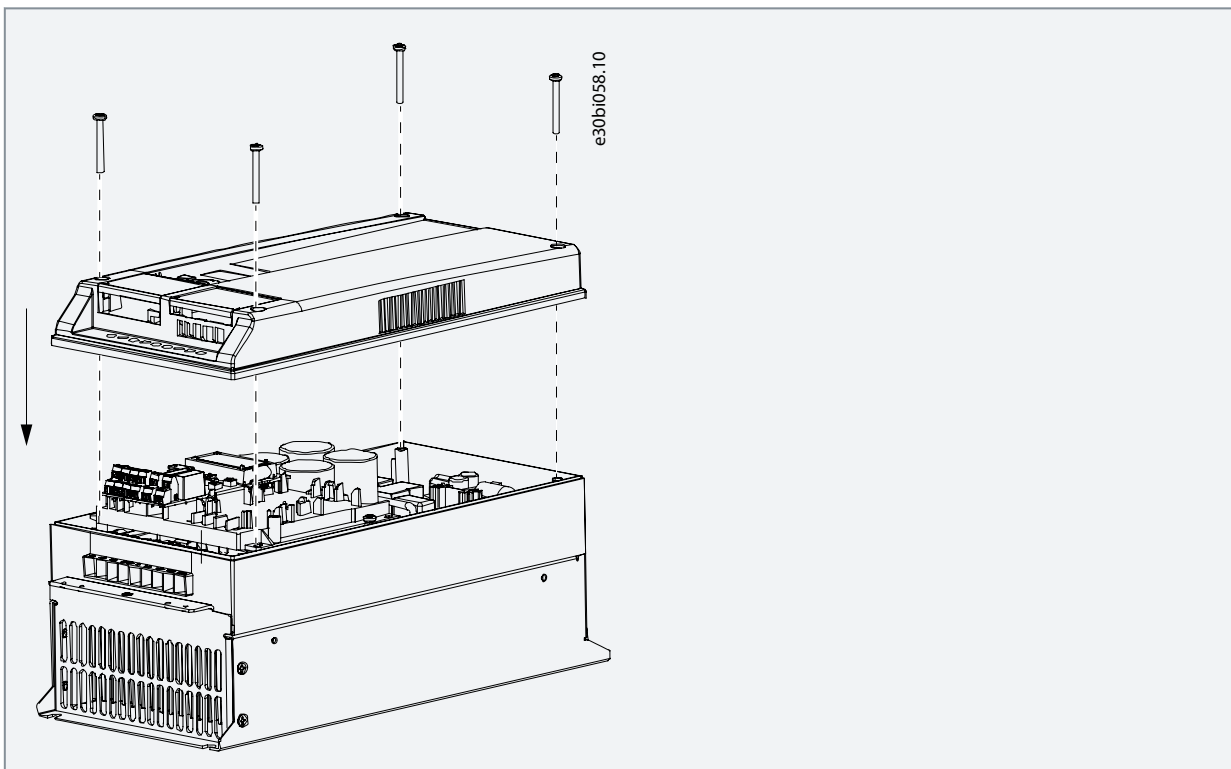

3.5 Installing Option Board in VACON® 20 X and 20 CP

This topic gives instructions for installing the option boards in VACON[®] 20 X and 20 CP, MU2–MU3, MS2–MS3.

Procedure

1. In VACON[®] 20 X, open the cover of the AC drive.

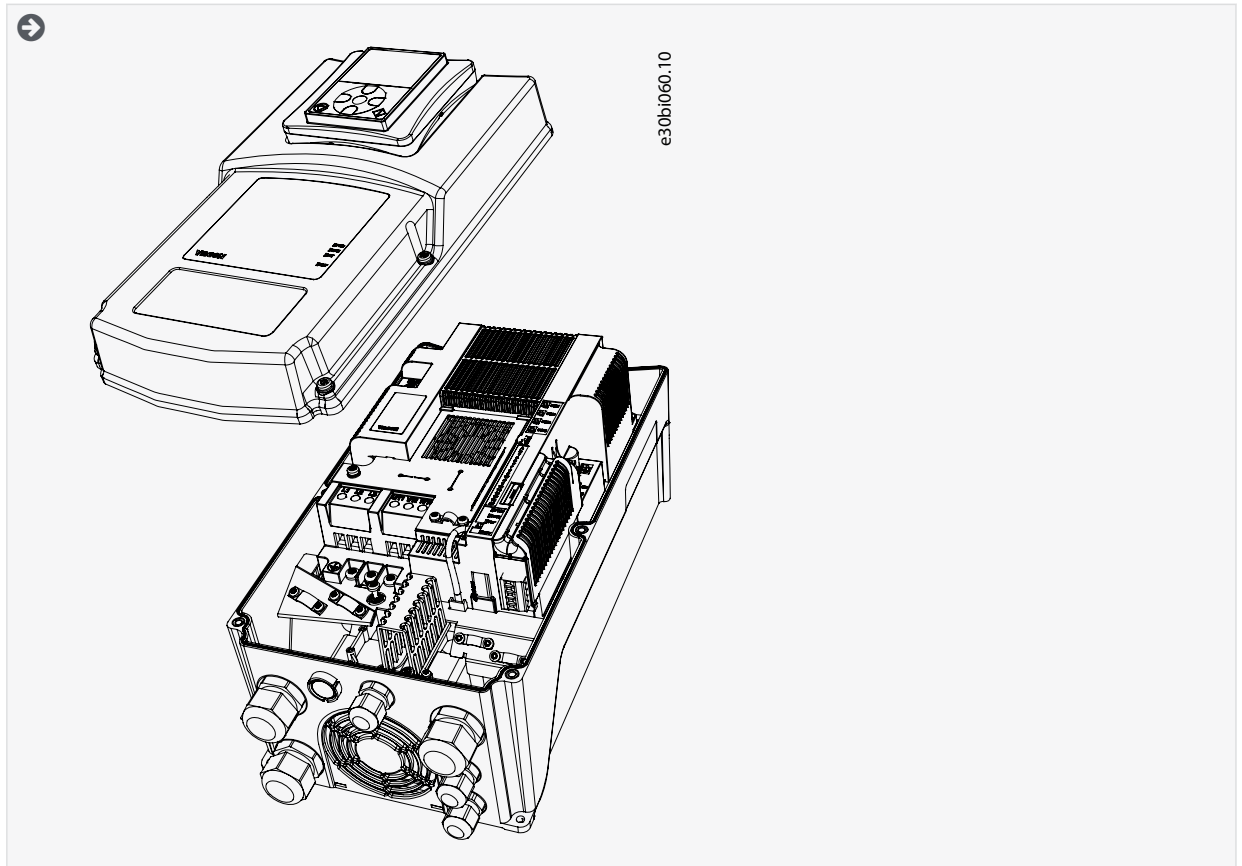

2. Remove the option board cover.

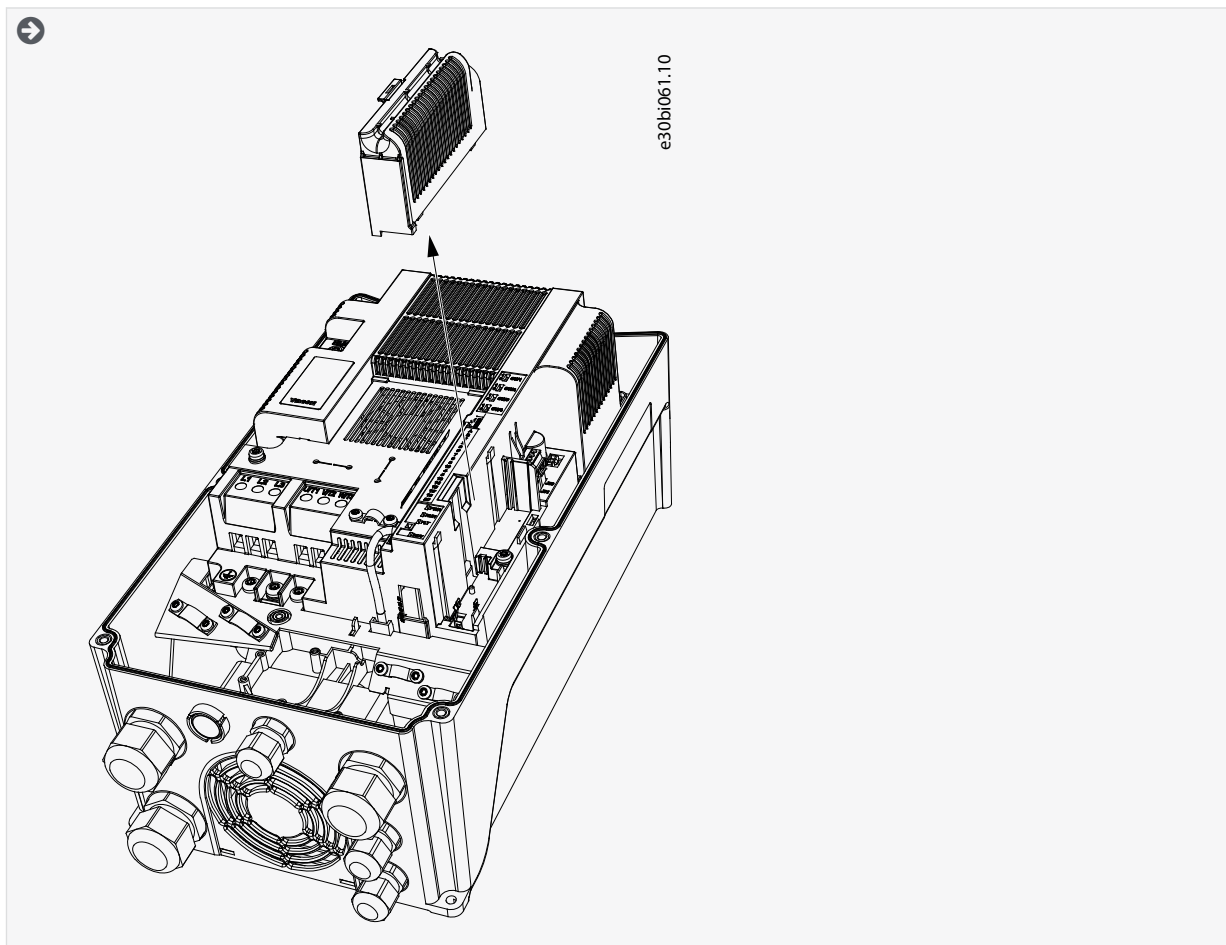

3. Install the option board into the slot.

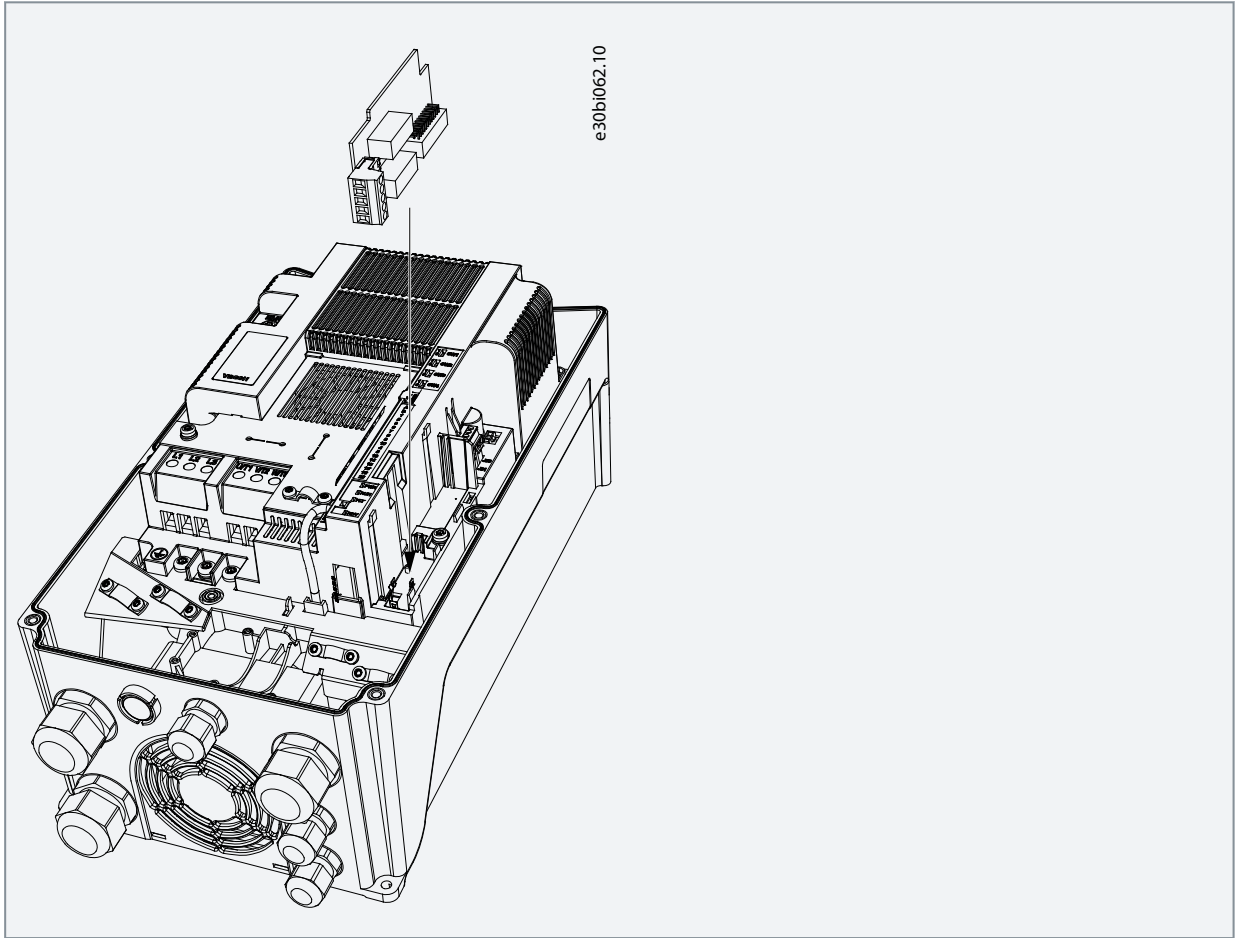

4. To make an opening for the option board connector, remove the plastic plate at the end of the option board cover. Attach the option board cover to the AC drive.

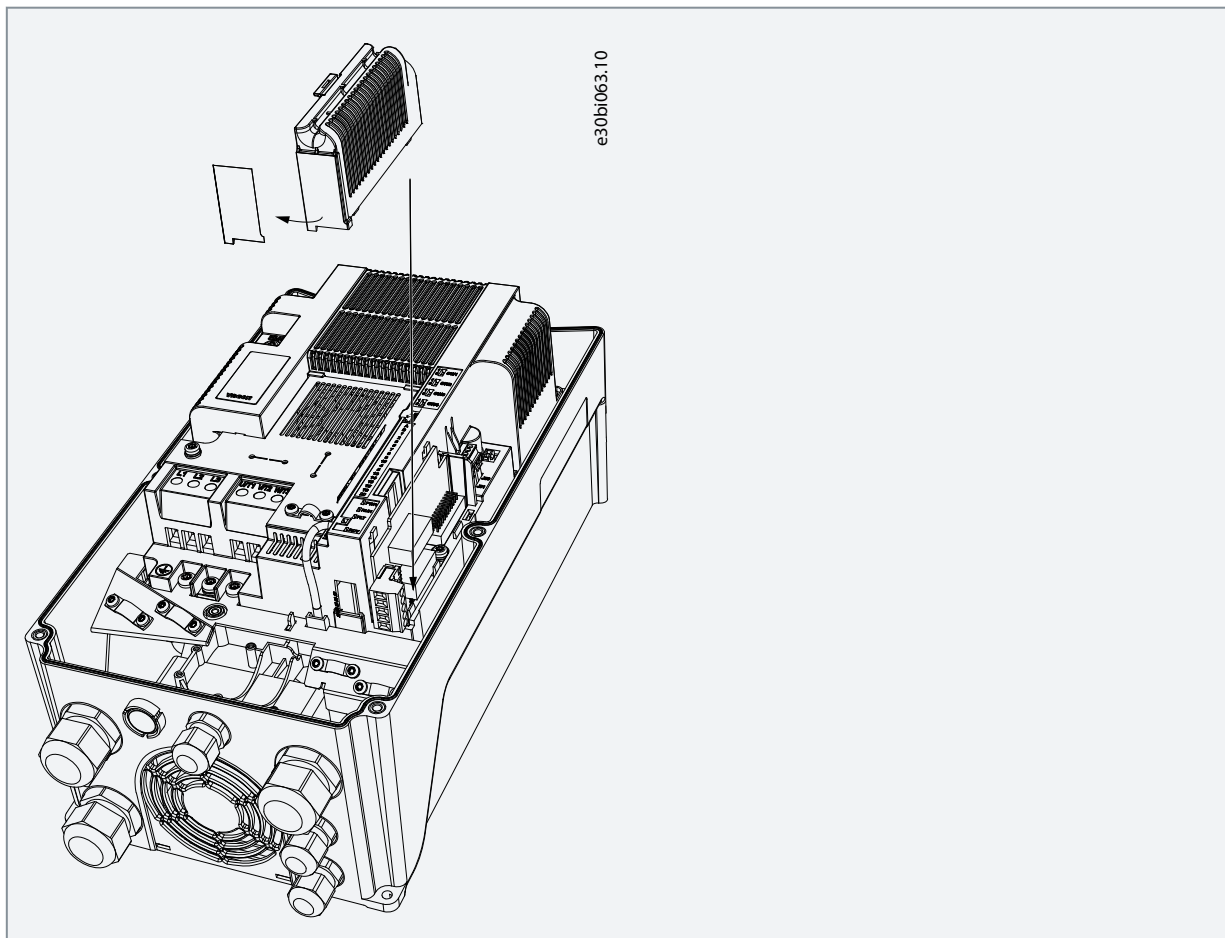

5. Close the cover of the AC drive.

4 Cabling

4.1 General Cabling Instructions for Fieldbus

To keep the response time and the number of incorrect dispatches to minimum, use only standard industrial components in the network and avoid complex structures. The requirements for commercial cabling components are specified in section 8-8 in the ANSI/TIA/EIA-568-B series standards. Using commercial components can decrease system performance. The use of such products or components can cause unsatisfactory performance in industrial control applications.

4.1.1 Cable Routing

It is important that fieldbus cables are routed separately from motor cables. The recommended minimum distance is 300 mm. Do not let fieldbus cables and motor cables cross each other. If it is not possible, the fieldbus cables must cross other cables at an angle of 90°.

Shielded fieldbus and control cables can be routed in parallel. To have further shielding, install a grounded metal conduit around the fieldbus and control cable run.

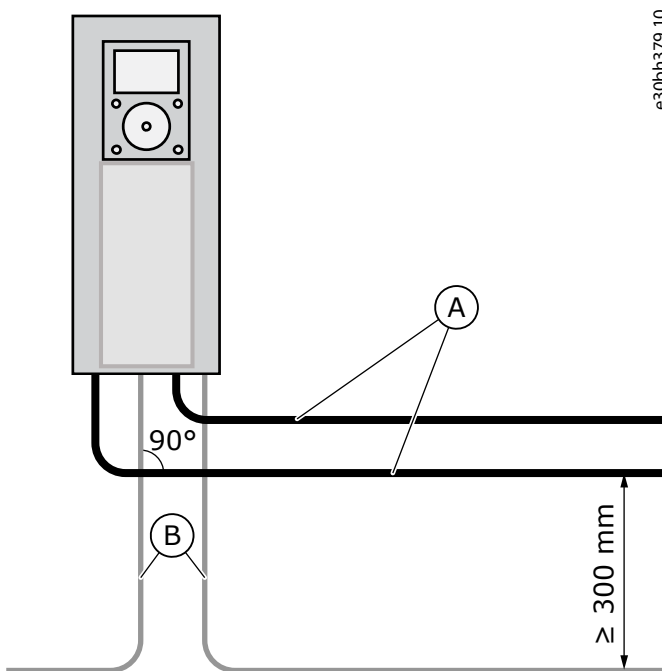

Illustration 3: Routing the Motor and Fieldbus Cables

A	Motor cables
B	Fieldbus cables

Use cables with right length. If there is extra cable, put it in a noise free location. Multiple rounds of cable and a large circumference area make an antenna (see [Illustration 4](#)). Noise connects to fieldbus cable and can cause communication problems.

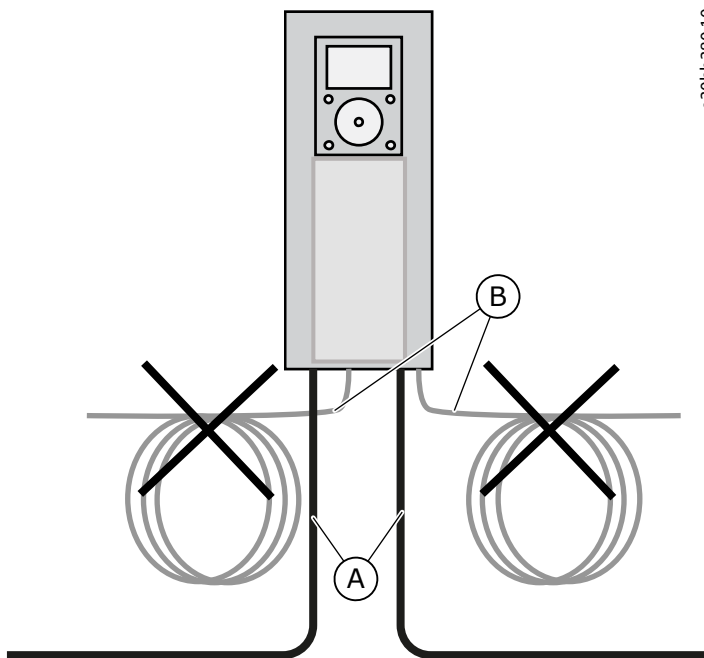

Illustration 4: Installation that Makes an Antenna

- | | |
|---|-----------------|
| A | Motor cables |
| B | Fieldbus cables |

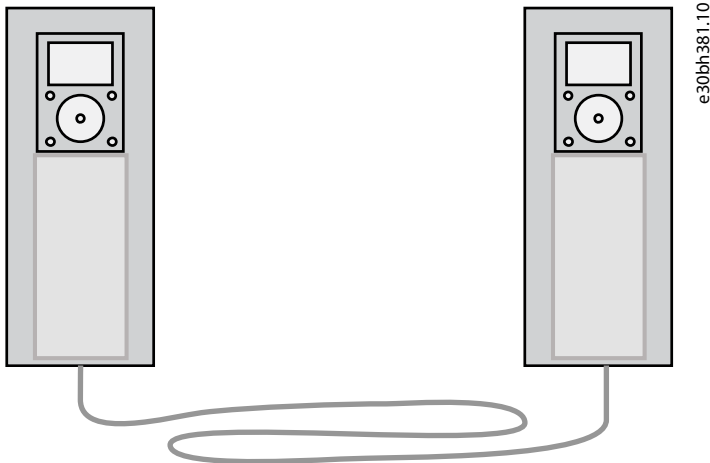

Illustration 5: Example of Good Routing of Extra Fieldbus Cable

NOTICE

To prevent shield fracture, do not bend the cable too much or run the cable back and forth on the same path too tightly.

4.1.2 Strain Relief

If there is a possibility of tensile load on the cable, install it with a strain relief. When it is possible, the strain relief of the fieldbus cables should not be done at the shield connection to ground. This may reduce the effectiveness of the bonding. The tensile load and vibration can also damage the shield.

4.2 General Cabling Instructions for RS485

Use only shielded cables with twisted-pair signal wires.

For example, the following cables are recommended:

- Lapp Kabel UNITRONICR BUS LD FD P A, part number 2170813 or 2170814
- Belden 9841

The plug type to be used is 2.5 mm² (AWG13).

The theoretical maximum cable length depends on baud rate. See the following table for suggested maximum cable lengths.

Table 4: The RS485 Cable Lengths

Baud rate (kbit/s)	Length of line A (m)	Length of line B (m)
9.6	1200	1200
19.2	1200	1200
93.75	1200	1200
187.5	1000	600
500	400	200
1500	200	-
3000–12000	100	-

4.3 Cable Requirements for CAN Type Option Boards

The recommended cables for installation are four-wire twisted and shielded cables with an impedance of 120 Ω. The network topology is a two-wire bus line that is terminated at both ends by resistors showing the characteristic impedance of the bus line.

The typical CAN bus cable impedance is 120 Ω, thus use termination resistance of ~120 Ω. For long networks, use a higher resistance value (150–300 Ω). Minimum cable length of 1 meter between two stations is recommended.

Table 5: Bus Parameter Relation to Cable Length

Cable length (m)	Maximum bit rate (kbit/s)	Maximum cable resistance (mΩ/m)	Bit rate supported by
0–40	1000	Maximum 70	CANopen
100	500	< 60	CANopen, DeviceNet
250	250	< 50	CANopen, DeviceNet
500	100	< 40	CANopen, DeviceNet
1000	50	< 26	CANopen

With CANopen and DeviceNet, use for example:

- UNITRONIC® BUS CAN FD P, Colour-coded in accordance with DIN 47100

Table 6: Cable Thickness, Length, and Baud Rate Relation

Bit rate	Maximum cable thickness (mm ²)				Bit rate supported by
1 Mbit/s	0.25	-	-	-	CANopen, DeviceNet
500 kbit/s	0.25	0.34	-	-	CANopen, DeviceNet
250 kbit/s	0.25	0.34	0.60	-	CANopen, DeviceNet
125 kbit/s	0.25	0.34	0.60	-	CANopen, DeviceNet

Bit rate	Maximum cable thickness (mm ²)				Bit rate supported by
	0.25	0.34	0.60	0.60	
100 kbit/s	0.25	0.34	0.60	0.60	CANopen
50 kbit/s	0.25	0.34	0.60	0.60	CANopen
Cable length (m)	25	100	250	500	-

4.4 Cable Requirements for LON Type Option Boards

Up to 64 FTT-10 transceiver nodes are allowed per network segment. Individual segments can be connected together with a router. See the following table for cable types and cable lengths recommended for FTT-10.

Even if unshielded cable types are recommended to be used with this type of transceiver, it is still highly recommended to use only shielded cables with AC drives. To ensure bus operation, pay attention to proper grounding of the shield. Minimum cable length of 1 meter between two stations is recommended. For LonWorks, use, for example, the cables listed in the following table.

Table 7: Recommended Cable Types and Lengths

Cable type	Maximum doubly terminated bus length	Maximum free topology wire length	Maximum node-to- node distance
Belden 85102 (unshielded)	2700	500	500
Belden 8471 LONAK 2 x 1.3 (unshielded)	2700	500	400
Level IV, 22 AWG LONAK 2 x 2 x 0.65 (unshielded)	1400	500	400
JY (St) Y 2 x 2 x 0.8 mm LONAK 2 x 2 x 0.8 (shielded)	900	500	320

4.5 Fieldbus Connectors

Option boards use two types of connectors. Either 5-pin screw connector or 9-pin Sub-D9 connector. The only exception is the OPTC4 option board which uses 3-pin screw connector.

For PROFIBUS DP, the following connectors can be used (180° cable outlet):

- Phoenix SUBCON-PLUS-PROFIB/AX/SC 27 44 38 0
- Siemens PROFIBUS connector 6GK1 500-0EA02

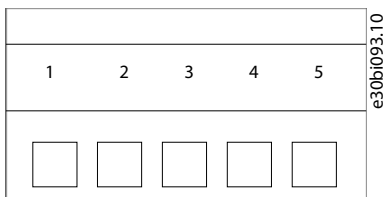

Illustration 6: The 5-pin Bus Connector

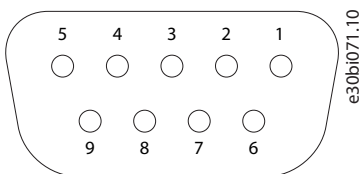

Illustration 7: The Sud-D9 Connector

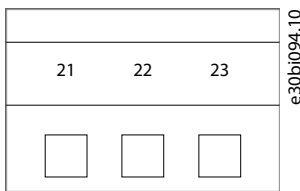

Illustration 8: The 3-pin Bus Connector for OPTC4 Option Board

4.6 Stripping the Cables

Stripping the data cables is necessary if the cables are not preinstalled with connectors. When planning to ground the cable shield directly to ground with 360° connection (see [5.2.1 Jumpers in the OPTC3/C5 Option Board](#)), do step 3 and strip the cable shield visible. Otherwise skip step 3 when installing cables.

Procedure

1. Remove approximately 15 mm of the gray shield of the fieldbus cable. Repeat for the 2 cables.
 - a. Remove approximately 15 mm of the shield of the fieldbus cable. Repeat to all data cables.
 - b. Strip the cables for approximately 15 mm to put them in the terminals. Do not keep more than 10 mm of the cable outside the terminals.
 - c. When grounding the cable shield directly to ground, strip the cable at such a distance from the terminal that it is possible to attach it to the frame with the cable clamp. Strip the cable at a maximum length of 15 mm. Do not remove the aluminum shield of the cable.



2. Connect the cable to the correct terminals on the terminal block of the option board.
3. Install strain relief and make the shield grounding. See more in [5.4.1 Exceptions in Connector Pin Outs](#).

4.7 Grounding the Cable Shield

Equipotential bonding refers to using metal parts to make ground potential everywhere in the installation the same, the system ground. If the ground potential of all the devices is the same, you can prevent current from flowing through paths that are not designed to have current. You can also shield cables efficiently.

An error in the equipotential bonding can cause bad quality or malfunction of the fieldbus communication. It is not easy to find an error in equipotential bonding. It is also not easy to correct errors in large installations after commissioning. Thus, in the planning phase it is important to plan the installation to get good equipotential bonding. In the commissioning phase, make the equipotential bonding connections carefully.

Do grounding with low HF impedance, for example, via backplane mounting. If ground connection wires are necessary, use wires that are as short as possible. Note that paint coating acts as an insulator on metal and prevents grounding. Remove paint coating before doing grounding.

This chapter describes the principles of cable shield grounding. Notice that the internal RS485 fieldbus in VACON 100^{FF} products does not have jumpers for grounding options.

Connect the cable shield directly to the frame of the AC drive (see [Illustration 9](#) and [Illustration 11](#)).

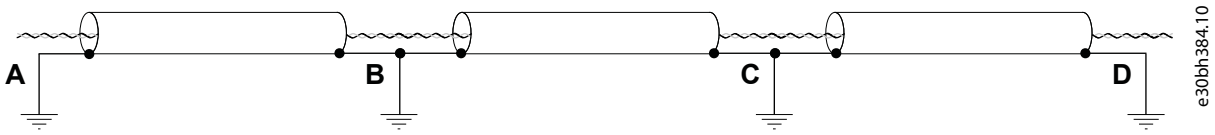

Illustration 9: Grounding in noisy environment with good equipotential. If potentials at points A, B, C and D are very different and cannot be made similar, cut the shields as in [Illustration Grounding in noisy environment with poor equipotential](#).

If ground potentials of the connected devices are different, cable shield that is connected at both ends causes current to flow in the shield. To prevent this, the cable shield must be disconnected or cut at some point between the devices (see [Illustration 10](#)). When disturbances are strong, the cable shield can be exposed and then 360 degrees grounded directly to the AC drive ground (see [Illustration 11](#)). When the connection is made like in [Illustration 10](#), grounding should be done at a location nearest to the place where the disturbances meet the cable.

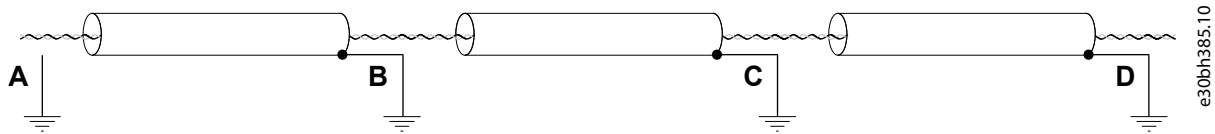

Illustration 10: Grounding in Noisy Environment with Poor Equipotential. An Example of Cutting the Shield.

We recommend grounding the cable shield as in examples A and C (see [Illustration 11](#)). Do not ground the cable shield as in example B.

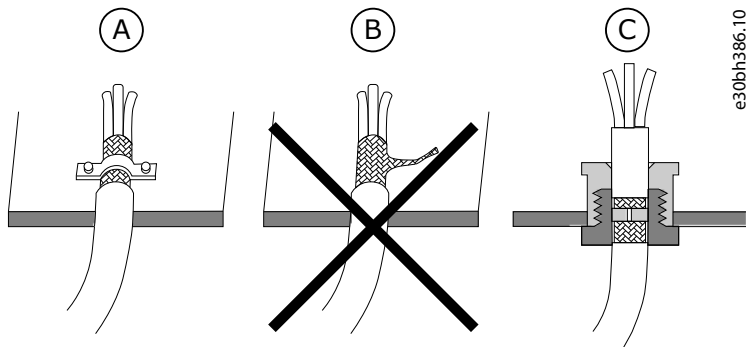

Illustration 11: Grounding the Cable Shield

A	Cable clamp	C	Cable gland
B	Ground terminal		

5 RS485-based Option Boards

5.1 Common Information for the OPTE3/E5 and OPTE2/E8 Option Boards

5.1.1 The OPTE3/E5 and OPTE2/E8 Option Board Layout

The fieldbus is connected to the OPTE3 and OPTE2 option boards using a 5-pin pluggable bus connector. The fieldbus is connected to the OPTE5 and OPTE8 option boards using a Sub- D9 connector. The option boards have the same layout regarding connectors, LEDs and jumpers. The following figure shows the board layout. OPTE5 and OPTE8 use a different fieldbus connector.

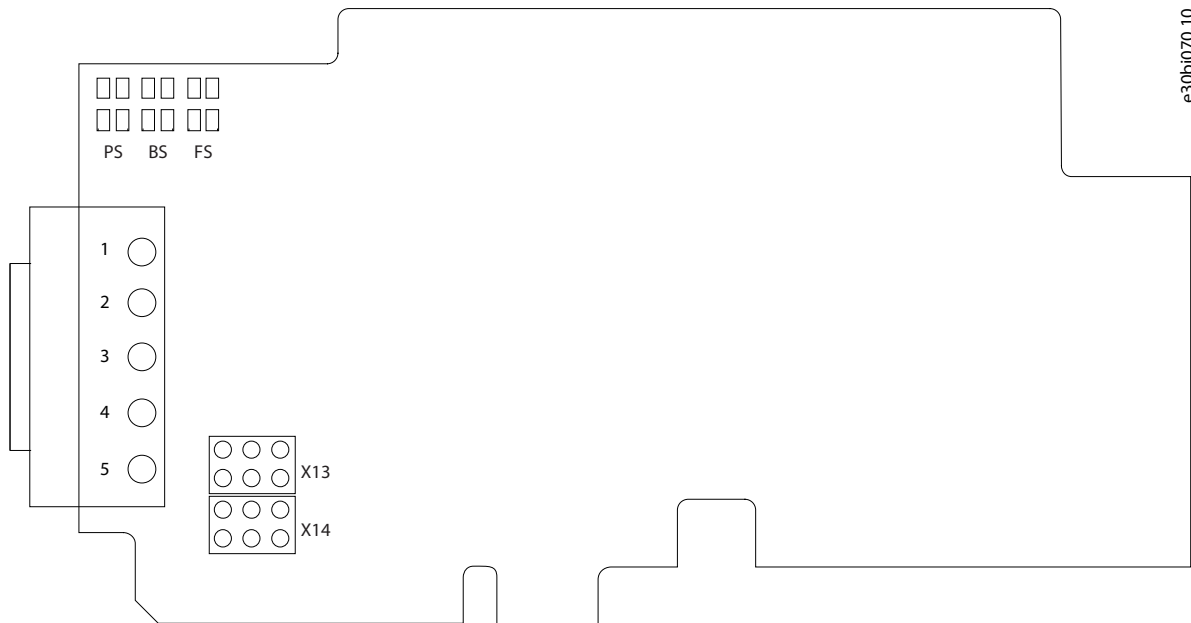

Illustration 12: The OPTE3/E5 and OPTE2/E8 Option Board Layout

Because of the different connectors, the signal pin layout in the cable connections are different. The following table describes the signals.

Table 8: The Connections of the Option Board

Signal	Connector pin Screw plug OPTE3, OPTE2	Sub-D9 OPTE5, OPTE8	Description
Shield	1	1	Cable shield
VP	2	6	Supply voltage - plus (5V)
RxD/TxD-P	3	3	Receive/Transmit data - plus (B)
RxD/TxD-N	4	8	Receive/ Transmit data - minus (A)
DGND	5	5	Data Ground (reference potential for VP)

5.1.2 The Jumpers in the OPTE3/E5 and OPTE2/E8 Option Boards

The jumper settings for these option boards are described in this chapter. For jumper locations, see [5.1.1 The OPTE3/E5 and OPTE2/E8 Option Board Layout](#).

If the AC drive is the last device on the bus, bus termination has to be set.

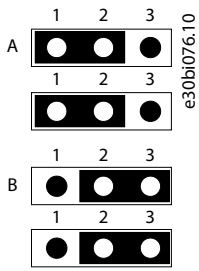

- A Bus termination is ON.
- B Bus termination is OFF (factory default setting).

Illustration 13: The Settings of the Jumper X13, Termination Resistor, Positions A and B

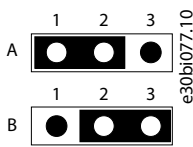

- A GND is connected to cable shield.
- B GND is not connected to cable shield (factory default setting).

Illustration 14: The Settings of the Jumper X14, Grounding, Upper Row, Positions A and B

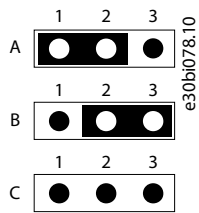

- | | |
|--|--|
| <ul style="list-style-type: none"> A Cable shield is connected directly to PE (factory default setting). B Cable shield is connected to PE through RC. | <ul style="list-style-type: none"> C Cable shield is not connected. |
|--|--|

Illustration 15: The Settings of the Jumper X14, Grounding, Lower Row, Positions A, B, and C

5.2 The OPTC3/C5 Option Board

Fieldbus is connected to the OPTC3 option board using a 5-pin pluggable bus connector, and to the OPTC5 option board using a Sub-D9 connector. OPTC5 uses a different fieldbus connector.

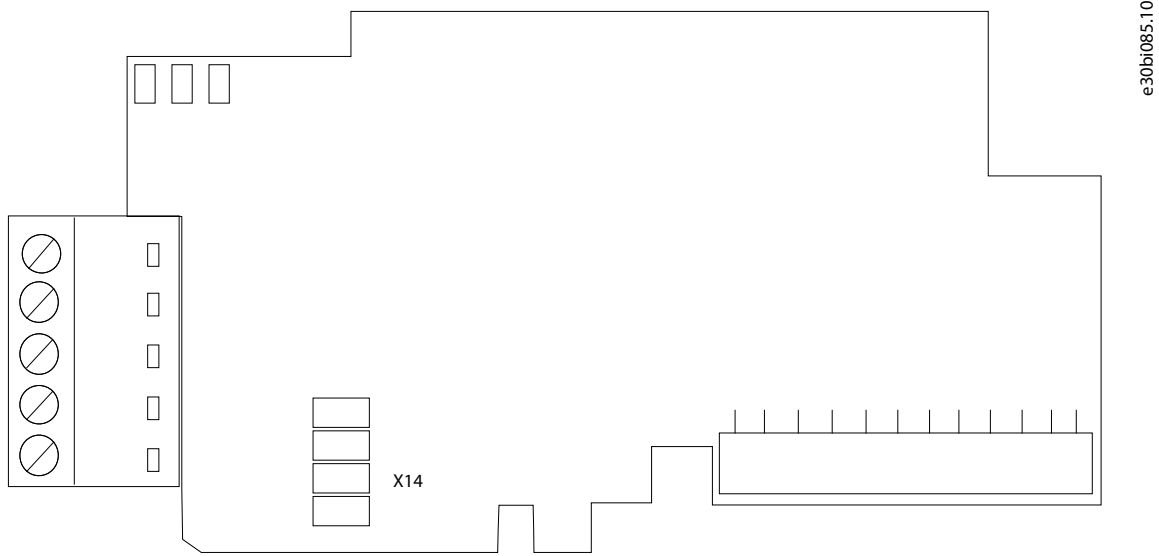

Illustration 16: The OPTC3/C5 option board layout

Due to the different connectors, the signal pin layouts in cable connections are different. The following table describes the signals.

Table 9: The Connections of the Option Board

Signal	Connector pin Screw plug OPTC3	Sub-D9 OPTC5	Description
Shield	1	1	Cable shield
VP	2	6	Supply voltage - plus (5 V)
RxD/TxD-P	3	3	Receive/Transmit data - plus (B)
RxD/TxD-N	4	8	Receive/ Transmit data - minus (A)
DGND	5	5	Data Ground (reference potential for VP)

5.2.1 Jumpers in the OPTC3/C5 Option Board

The jumper settings for these option boards are described in this chapter. For jumper locations on the option board, see [5.2 The OPTC3/C5 Option Board](#).

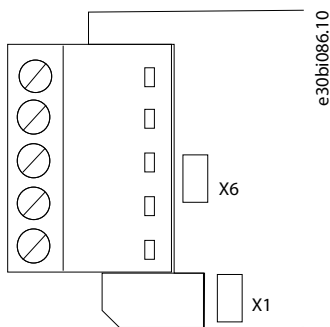
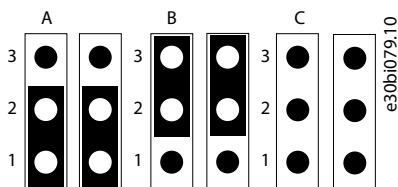
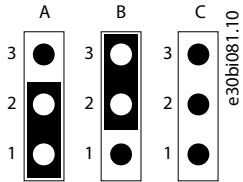

Illustration 17: Jumper Locations on OPTC3/C5



A	Bus termination is ON	C	Bus termination is OFF. Termination resistor is not connected.
B	Bus termination is OFF (factory default setting)		

Illustration 18: The Settings of the Jumper X6 on Board, Termination Resistor, Positions A, B, and C



A	Cable shield is connected directly to PE.	C	Cable shield is connected to PE through RC when jumper is not connected.
B	Cable shield is connected to PE through RC (factory default setting).		

Illustration 19: The Settings of the Jumper X1 on Board, Cable Shield Grounding, Positions A, B, and C

5.3 Cabling and bus termination for PROFIBUS option boards

The PROFIBUS devices are connected in a bus line. Up to 32 stations (master or slaves) can be connected in one segment. The bus is terminated at the beginning and end of each segment (see [Illustration 20](#)). The bus termination at both ends of the segment must always be powered. When more than 32 stations are used, repeaters (line amplifiers) must be used to connect the bus segments.

The maximum cable length depends on the transmission speed and cable type ([4.1 General Cabling Instructions for Fieldbus](#)). The specified cable length can be increase by using repeaters. The use of more than three repeaters in series is not recommended.

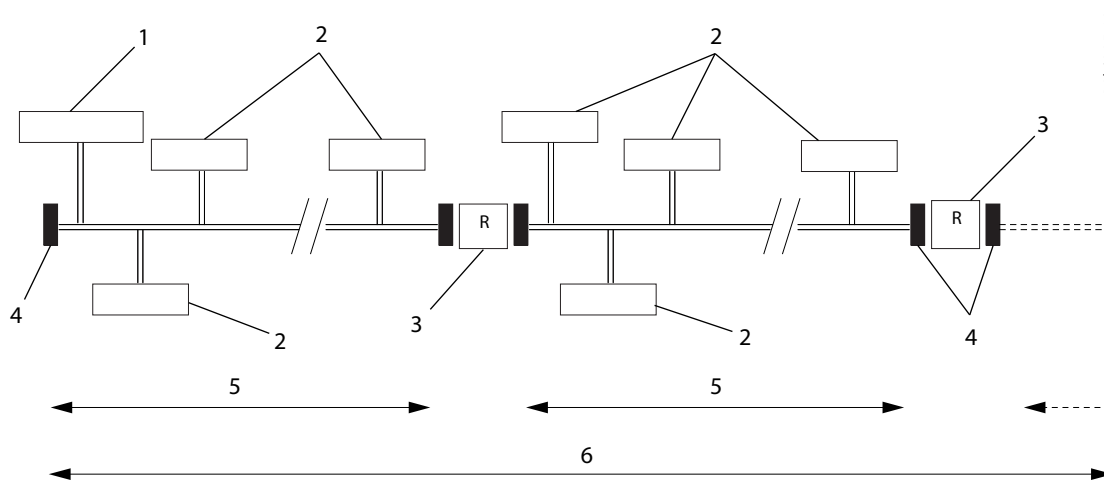

1	Master	4	Termination resistor
2	Slave	5	32 devices/segment
3	Bus repeater	6	Maximum of 126 stations (4-segment)

Illustration 20: The Cabling and Bus Termination for PROFIBUS DP Option Boards

5.4 The OPTE2/OPTE8 Option Boards

5.4.1 Exceptions in Connector Pin Outs

When replacing the OPTC2 option board with the OPTE2/E8 option board, note that the pins for Receive/Transmit data - Plus (B) and Receive/Transmit data - Minus (A) have switched places. In OPTC2/C8, the first pin is not connected to the cable shield.

5.4.2 The Bus Terminal and Bias Resistors

If the AC drive is the last device in the RS485 bus line, bus termination must be set. Use the jumper X13 (ON position) or external termination resistors.

Bus biasing is required to make sure that communication between the devices in the RS485 bus line is faultless. Bus biasing makes sure that the bus state is in the proper potential when no device is transmitting data. Without bus biasing, incorrect messages can be detected when the bus is in idle state. The bus state of the RS485 bus line must not be between +0.200...+7 V or -0.200...-7 V. The bus state <200 mV...-200 mV is illegal.

The resistances of internal termination and biasing are 120 Ω and 560 Ω.

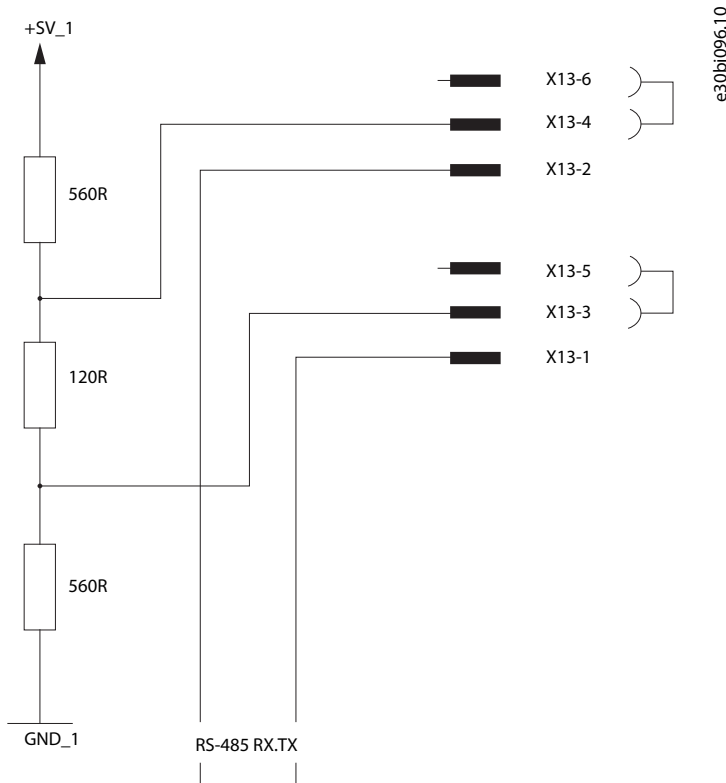

Illustration 21: Bus Termination and Biasing

If necessary, external termination and biasing can be added depending on the number of nodes and the total length of the cable.

Table 10: Bias and Termination Resistances

Number of nodes	Bias resistance	Termination resistance
2–5	1.8 kΩ	120 kΩ
6–10	2.7 kΩ	120 kΩ
11–20	12 kΩ	120 kΩ
21–30	18 kΩ	120 kΩ
31–40	27 kΩ	120 kΩ

If setting the jumpers does not give the desired outcome, add biasing resistors, termination resistors or both. For biasing with OPTE2, connect the resistors between pins 2 and 3 and between pins 4 and 5. For termination with OPTE2, connect the resistor between pins 3 and 4.

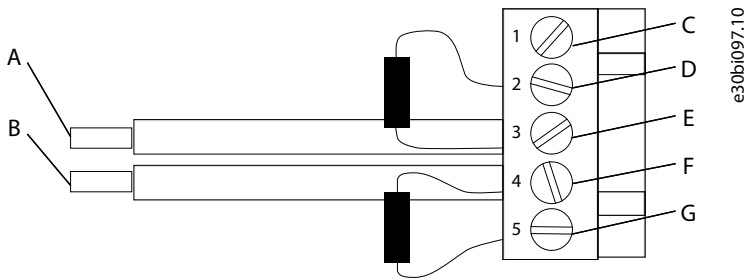

e30bi097.10

A	Data A +	E	Plus
B	Data B -	F	Minus
C	Shield	G	Data Ground
D	VP		

Illustration 22: Fail-safe Biasing in OPTe2

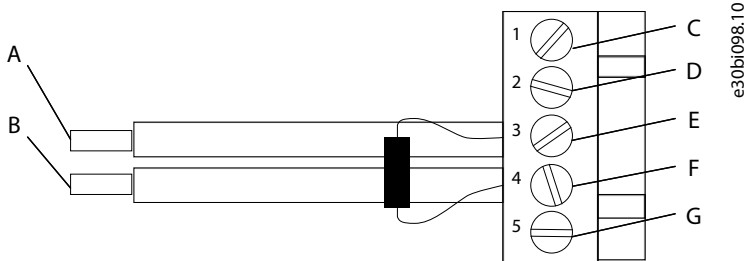

e30bi098.10

A	Data A +	E	Plus
B	Data B -	F	Minus
C	Shield	G	Data Ground
D	VP		

Illustration 23: Termination Resistance in OPTe2

5.4.3 Setting the Termination Resistance

Install termination resistance near both ends of the RS485 segment. The typical termination resistance for RS485 is 120 Ω.

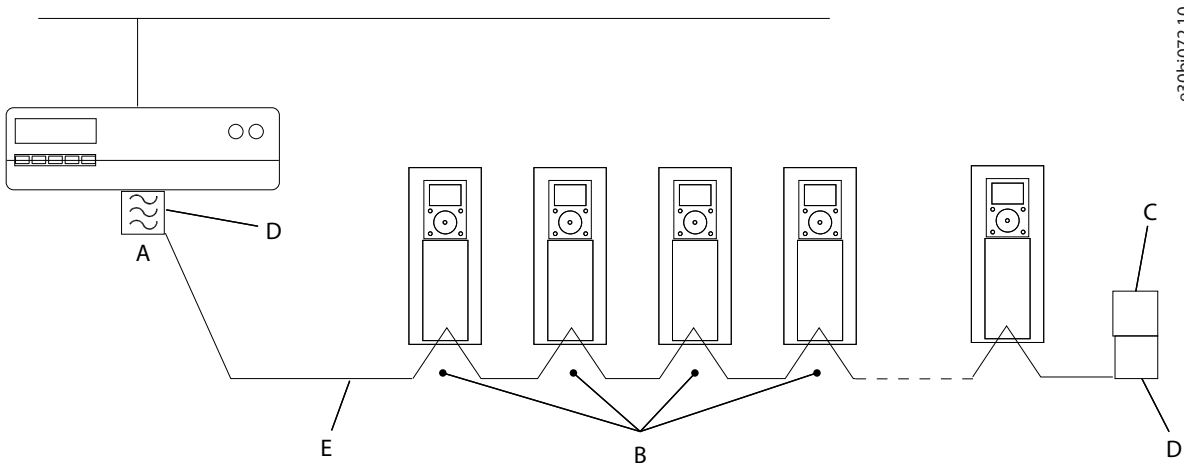

e30bi072.10

A	The termination is activated	D	The bus termination
B	The termination is deactivated	E	The fieldbus cable
C	The termination is activated with a jumper		

Illustration 24: Setting the Termination Resistance

5.5 The OPTC2/C8 and OPTCJ Option Boards

Fieldbus is connected to the OPTC2 and OPTCJ option boards using a 5-pin pluggable bus connector, and to the OPTC8 option board using a Sub-D9 connector. OPTC2 and OPTCJ have a common physical board layout. OPTC8 uses a different fieldbus connector.

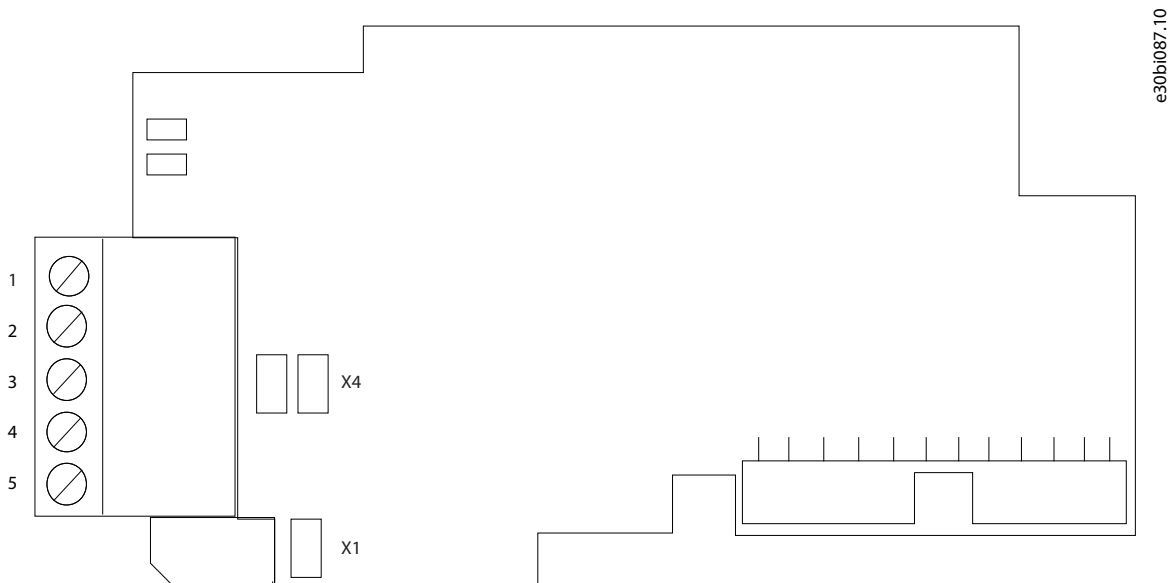

Illustration 25: The OPTC2, OPTC8, and OPTCJ option board layout

Due to the different connectors, the signal pin layouts in cable connections are different. The following table describes the signals.

Table 11: The Connections of the Option Board

Signal	Connector pin Screw plug OPTC2, OPTCJ	Sub-D9 OPTC8	Description
Shield ⁽¹⁾	1	1	No connection in OPTC2 or OPTCJ. In OPTC8 cable shield.
VP	2	6	Supply voltage - plus (5 V)
RxD/TxD-P	4	8	Receive/Transmit data - plus (B)
RxD/TxD-N	3	3	Receive/ Transmit data - minus (A)
DGND	5	5	Data Ground (reference potential for VP)

¹ Use pin 1 to bypass the cable shield to the next slave in OPTC2 and OPTCJ with screw plug.

5.5.1 Jumpers in the OPTC2/C8, and OPTCJ Option Boards

For jumper settings, see [Illustration 26](#) and [Illustration 27](#). The jumper X1 has no effect on OPTC2 or OPTCJ.

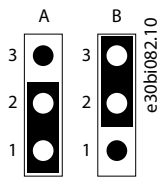

- A Cable shield is connected directly to PE.
- B Cable shield is connected to PE through RC (factory default setting).

Illustration 26: The settings of the jumper X1 for OPTC8, Cable Shield Grounding, positions A, and B

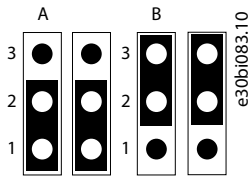

- A Bus termination is ON.
- B Bus termination is OFF (factory default setting).

Illustration 27: The Settings of the Jumper X4, Bus Terminal Resistor, Positions A, and B

If setting the jumpers does not give the desired outcome, add biasing resistors, termination resistors or both. For biasing with OPTC2, connect the resistors between pins 2 and 4 and between pins 3 and 5. For termination with OPTC2, connect the resistor between pins 3 and 4.

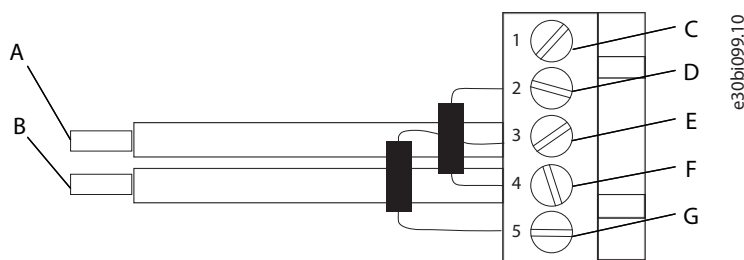

A	A data +	E	Minus
B	B data -	F	Plus
C	N/A	G	Data Ground
D	VP		

Illustration 28: The Fail-safe Biasing in OPTC2

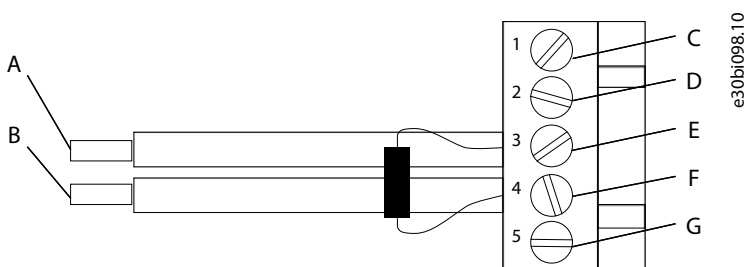

A	A data +	E	Minus
B	B data -	F	Plus
C	N/A	G	Data Ground
D	VP		

Illustration 29: The termination resistance in OPTC2

6 CAN Type and Other Fieldbus Option Boards

6.1 The OPTE6 and OPTE7 Option Boards

6.1.1 The OPTE6 and OPTE7 Option Board Layout

The OPTE6 and OPTE7 option boards have two different hardware revisions with slightly different layout. The layout is different in the LED arrangement and termination resistor orientation. The two hardware revisions are marked with different product codes. The product code is marked in the sticker on top of the option board.

The hardware versions are listed in the following table.

Table 12: Hardware Versions

Board	In production starting from 2017	Not in production
OPTE6	70CVB01605 (141X4171)	70CVB01124 (141X3915)
OPTE7	70CVB01817 (141X4403)	70CVB01555 (141X4133)

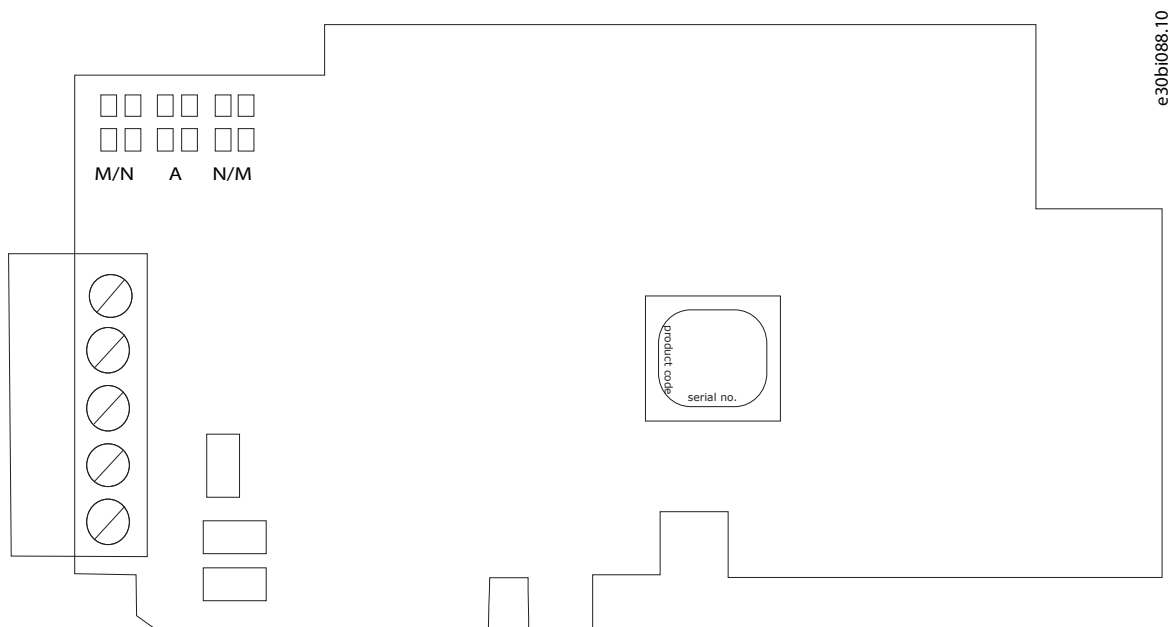

Illustration 30: The OPTE6 and OPTE7 Option Board Layout Combining the Old and New Hardware Versions

OPTE6 and OPTE7 have one difference in signals. In OPTE7, communication power supply is connected to pin 5. OPTE6 has no connection.

Table 13: The Connections of the Option Board

Signal	Connector pin Screw plug OPTE3, OPTE2	Sub-D9 OPTE5, OPTE8	Description
V-	1	1	CAN bus GND V- isolated digital ground reference
CAN LO	2	2	CAN bus LO
Shield	3	3	Shield connector
CAN HI	4	4	CAN bus HI
V+	N/A	5	V+ (24 V) for DeviceNet. Not connected for CANopen.

6.1.2 The Jumpers in the OPTE6 and OPTE7 Option Boards

The locations of the termination resistor jumpers depend on the hardware version, see [Illustration 31](#).

Installation Guide

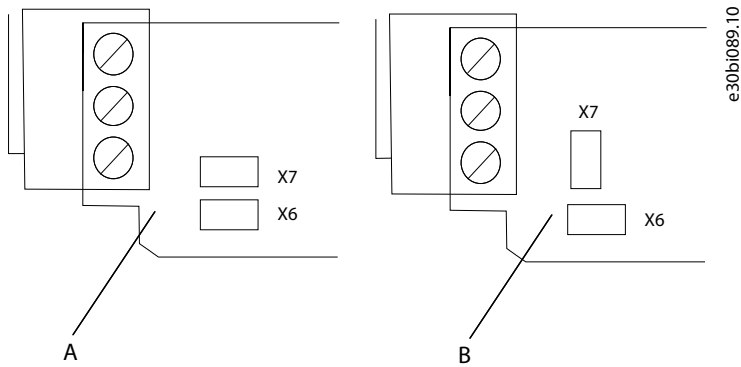

- | | |
|---|---|
| A | Hardware versions 70CVB01605 (141X4171) and 70CVB01817 (141X4403) |
| B | Hardware versions 70CVB01124 (141X3915) and 70CVB01555 (141X4133) |

Illustration 31: The Location of the Jumpers

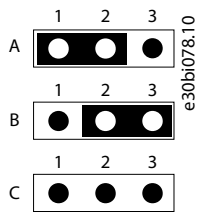

- | | | | |
|---|---|---|---|
| A | Termination resistor 120 Ω is connected. | C | Termination resistor is not connected to the CAN bus. |
| B | Termination resistor is not connected to the CAN bus (factory default setting). | | |

Illustration 32: The Settings of the Jumper X7 on 70CVB01605 (141X4171) and 70CVB01817 (141X4403), Bus Terminal Resistor, Positions A, B, and C

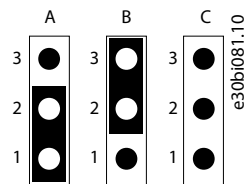

- | | | | |
|---|---|---|---|
| A | Termination resistor 120 Ω is connected. | C | Termination resistor is not connected to the CAN bus. |
| B | Termination resistor is not connected to the CAN bus (factory default setting). | | |

Illustration 33: The Settings of the Jumper X7 on 70CVB01124 (141X3915) and 70CVB01555 (141X4133), Bus Terminal Resistor, Positions A, B, and C

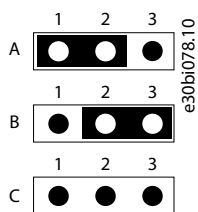

Installation Guide

<p>A CAN bus connector pin 3 (shield) is connected directly to the drive chassis (factory default setting). This option is recommended when equipotential bonding is good.</p> <p>B CAN bus connector pin 3 (shield) is connected to the drive chassis with a high-impedance RC circuit. This option is recommended when equipotential bonding is poor.</p>	<p>C CAN bus connector pin 3 is not connected.</p>
---	--

Illustration 34: The Settings of the Jumper X6, CAN Bus Cable Shield Grounding, positions A, B, and C

6.2 The OPTC6 Option Board

6.2.1 The OPTC6 Option Board Layout

Fieldbus is connected to the OPTC6 option board using a 5-pin screw plug.



Illustration 35: The OPTC6 Option Board Layout

Table 14: The Connections of the Option Board

Signal	Connector pin	Description
V-	1	CAN GND V- isolated digital ground reference
CAN LO	2	CAN LO
Shield connector	3	Shield connector
CAN HI	4	CAN HI
V+	N/A	Not connected for CANopen.

6.2.2 The Jumpers in the OPTC6 Option Board

For the jumper settings, see [Illustration 36](#) and [Illustration 37](#).

Installation Guide

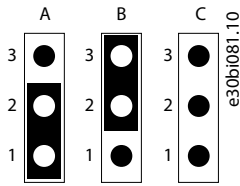

A	Cable shield is connected directly to PE (factory default setting).	C	Cable shield is connected to PE through RC.
B	Cable shield is connected to PE through RC.		

Illustration 36: The Settings of the Jumper X1, Cable Shield Grounding, Positions A, B, and C.

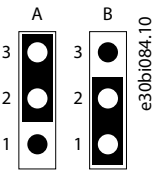

A	Bus termination is ON.
B	Bus termination is OFF (factory default setting).

Illustration 37: The Settings of the Jumper X6, Bus Terminal Resistor, positions A and B

6.3 The OPTC7 Option Board

6.3.1 The OPTC7 Option Board Layout

The OPTC7 option board is a DeviceNet fieldbus board that uses CAN bus as the communication layer.

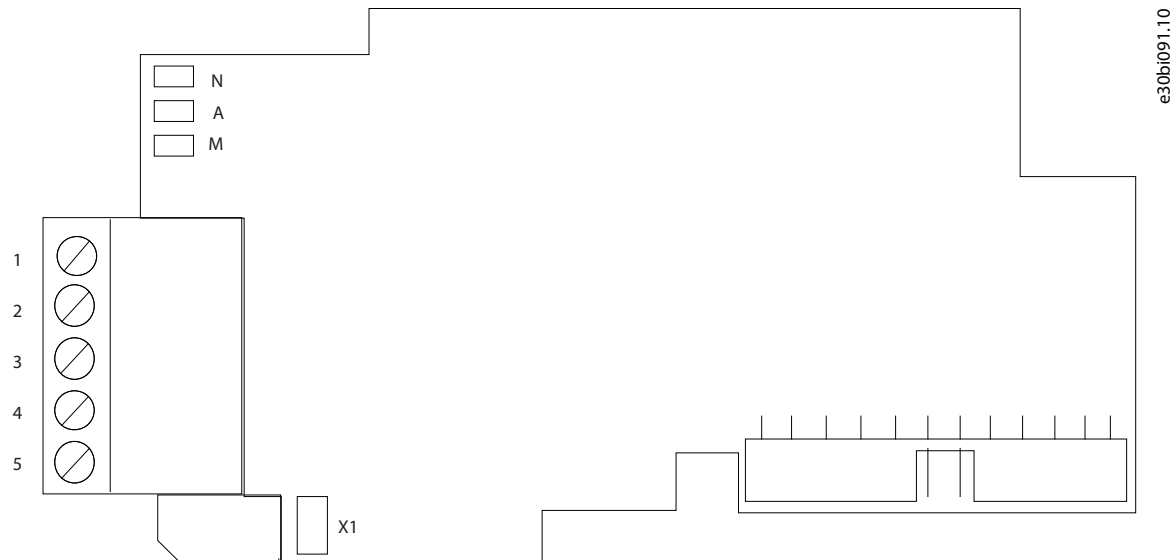

Illustration 38: The OPTC7 Option Board Layout

Table 15: The Connections of the Option Board

Signal	Connector pin	Description
V-	1	CAN GND V- isolated digital ground reference
CAN LO	2	CAN bus LO

Installation Guide

Signal	Connector pin	Description
Shield connector	3	Shield connector
CAN HI	4	CAN bus HI
V+	5	V+ (24 V), Communication power supply

6.3.2 The Jumpers in the OPTC7 Option Board

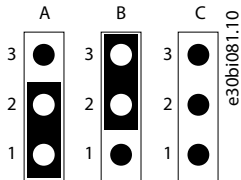

A	Cable shield is connected directly to PE (factory default setting).	C	Cable shield is connected to PE through RC.
B	Cable shield is connected to PE through RC.		

Illustration 39: The Settings of the Jumper X1, Cable Shield Grounding, Positions A, B, and C.

6.4 The OPTC4 Option Board

6.4.1 The OPTC4 Option Board Layout

The OPTC4 option board is connected to fieldbus through a 3-pin pluggable bus connector. The communication with the control board occurs through the standard VACON® interface board connector.

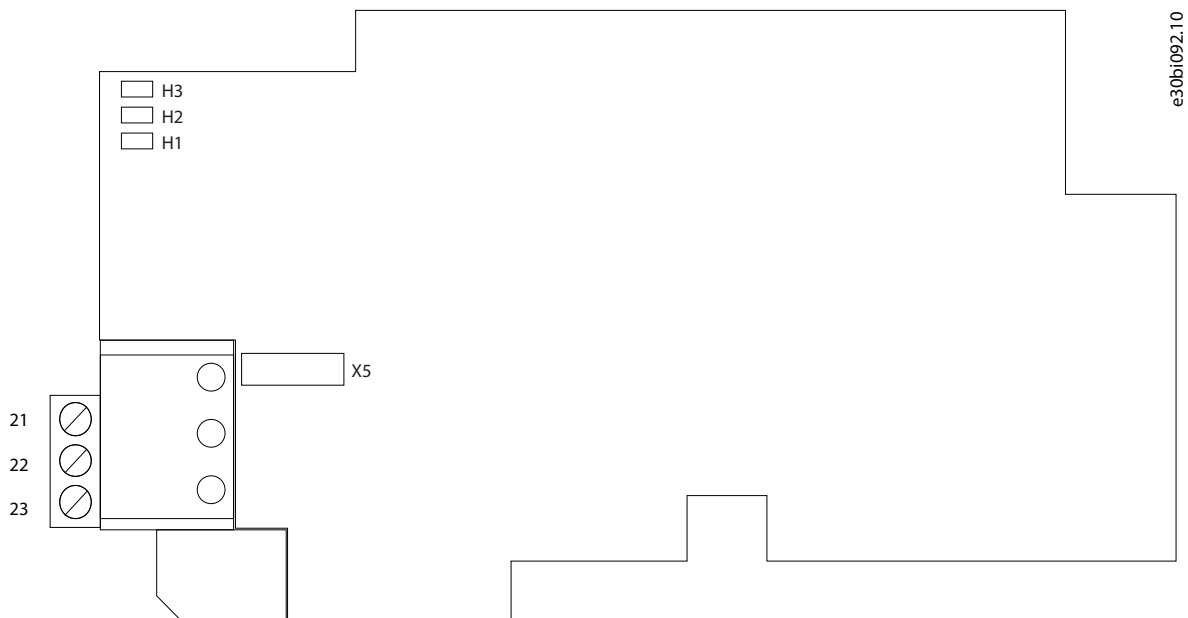

Illustration 40: The OPTC4 Option Board Layout

Installation Guide

Table 16: The Bus Connector Signals

Signal	Connector	Description
A1	21	Data
A2	22	Data
0 Shield	23	Shield

6.4.2 The Jumpers in the OPTC4 Option Board

To make sure that data is transmitted correctly, network segments must be terminated. One or two terminations are necessary depending on the network type. A free topology network segment requires only one termination whereas a doubly terminated bus topology requires two.

The jumper X5 on the option board must be set accordingly. Use the termination resistance of 94 Ω when only one termination is needed and 47 Ω for two terminations. The bus termination settings for the jumper X5 are shown in the following figure.

A	47 Ω	C	No termination
B	94 Ω		

Illustration 41: The Settings of the Jumper X5, Bus Terminal Resistor, Positions A, B, and C

Unlike other option boards described in this manual, OPTC4 does not have jumpers to control cable shield grounding. The cable shield of OPTC4 is always connected to ground through RC circuit. It means that direct shield groundings and/or shield disconnecting (that is, cutting) must be done externally.

6.4.3 The OPTC4 Option Board Topologies

LonWorks networks can be implemented on many different physical media. The OPTC4 option board has an FT-X1 transceiver supporting the Free Topology transformer coupled network. It makes it possible for the network cable to be connected as bus, star, or loop topology, or a combination of these topologies. This medium has a maximum bit rate of 78 kbit/s. The FT-X1 transceiver is compatible with Echelon’s LPT-10 Link Power transceiver, and these transceivers can communicate with each other on a single twisted-pair cable.

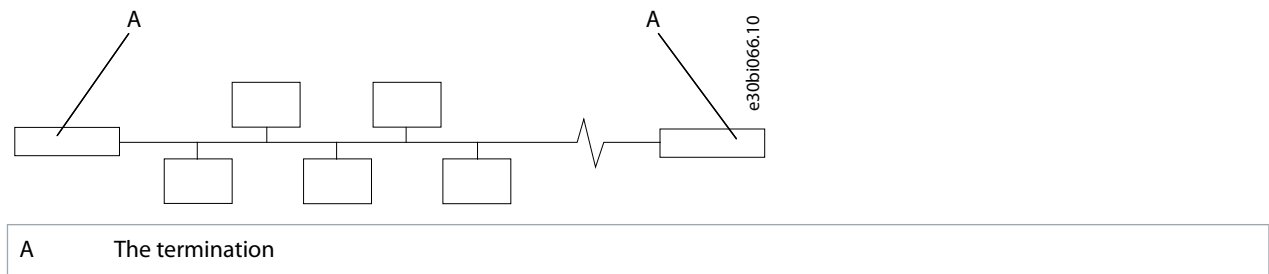
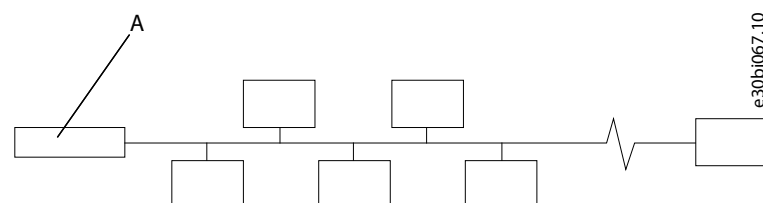

Illustration 42: Doubly Terminated Bus Topology



Installation Guide

A The termination

Illustration 43: Singly Terminated Bus Topology

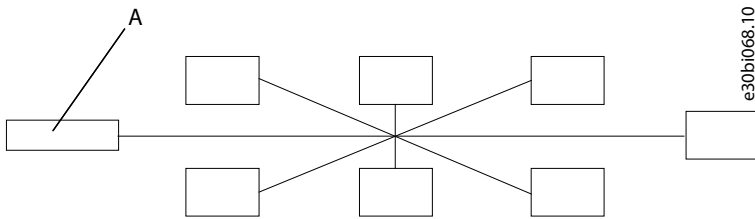

A The termination

Illustration 44: Star Topology

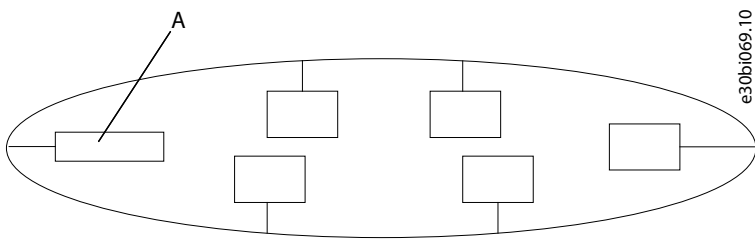

A The termination

Illustration 45: Loop Topology

7 Troubleshooting

7.1 LED Indications on PROFIBUS Option Boards

The LED indications are the same on all PROFIBUS option boards.

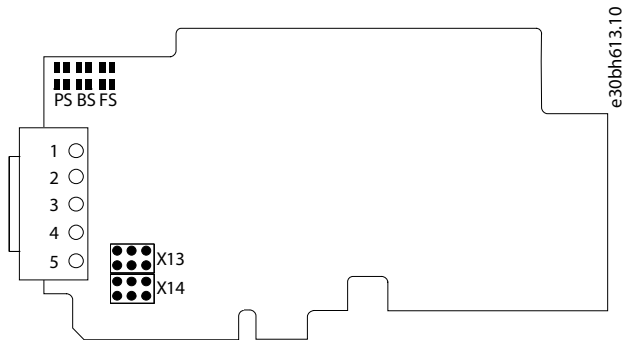

Illustration 46: LED Indications on VACON® PROFIBUS Option Boards

PS	PROFIBUS status, RED	FS	Fieldbus status, GREEN
BS	PROFIBUS board status, YELLOW		

Table 17: PS = PROFIBUS Status, RED

LED status	Description
OFF	PROFIBUS DP communicates normally
ON	PROFIBUS DP communication is broken or not started <ul style="list-style-type: none"> • Bus cable broken or incorrectly connected • Wrong configuration or parameterization data of Master • Master is offline or shutdown
Blinking yellow	The software is restarting

Table 18: BS = PROFIBUS Board Status, YELLOW

LED status	Description
OFF	Option board not activated
ON	Option board in initialization state waiting for activation command from the AC drive
Blinking fast (once per 1 s)	Option board is activated and in RUN state <ul style="list-style-type: none"> • Option board is ready for external communication
Blinking slow (once per 5 s)	Option board is activated and in FAULT state <ul style="list-style-type: none"> • Internal fault on optionboard

Table 19: FS = Fieldbus Status, GREEN

LED status	Description
OFF	Fieldbus module is waiting for parameters from the AC drive <ul style="list-style-type: none"> No external communication
ON	Fieldbus module is activated <ul style="list-style-type: none"> Parameters received and module activated Module is waiting for messages from the bus
Blinking fast (once per 1 s)	Module is activated and receiving messages from the bus
Blinking slow (once per 5 s)	Module is in FAULT state <ul style="list-style-type: none"> No messages from Net within the watchdog time Bus broken, cable loose, or Master offline

7.2 LED Indications on OPTE2/E8 Option Boards

The LED indications are the same on OPTE2 and OPTE8 option boards.

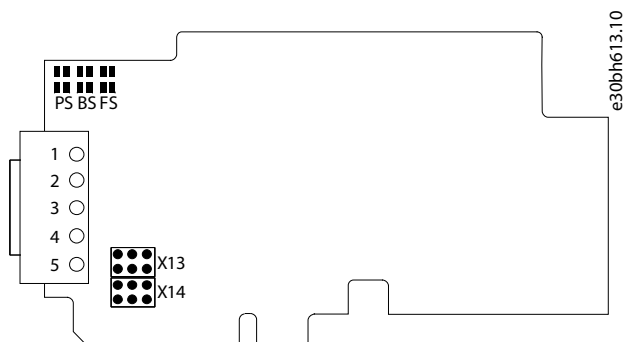

Illustration 47: LED Indications on VACON® OPTE2/E8 Option Boards

PS	Protocol status	FS	Fieldbus status
BS	Board status		

Table 20: PS = Protocol Status

LED status	Description
OFF	Protocol is not ready for communications
ON (Green)	Protocol is communicating
Blinking yellow (1 s ON / 1 s OFF)	Protocol is ready for external communication
Blinking green (fast)	Firmware is corrupted or missing

Table 21: BS = Board Status

LED status	Description
ON (green)	Board is operational
Blinking red (1 s ON / 1 s OFF)	Protocol is in fault state

Table 22: FS = Fieldbus Status

LED status	Description
OFF	Protocol is not communicating
ON (green)	Protocol is communicating

Table 23: LED Combinations

PS	BS	FS	Description
OFF	OFF	OFF	No power. All LEDs are OFF
Green blinking (fast)	OFF	OFF	Option board firmware is corrupted or missing.
OFF	Green	OFF	Option board is operational
Yellow blinking (1 s ON / 1 s OFF)	Green	OFF	Protocol is ready for communications.
Green	Green	Green	Protocol is communicating. The option board is receiving requests from the PLC master and sending responses to the requests.
Yellow blinking	Red blink- ing	OFF	Protocol communication fault. BS is blinking to indicate a fault. PS is blinking to indicate that protocol is ready for communications.

7.3 LED Indications on OPTC2/C8 and OPTCJ Option Boards

The LED indications are the same on OPTC2/C8 and OPTCJ option boards.

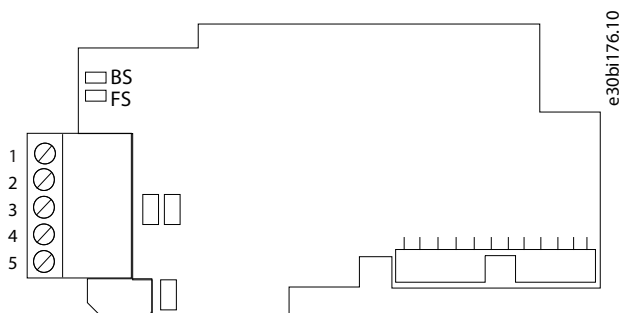

Illustration 48: LED Indications on VACON[®] OPTC2/C8 and OPTCJ Option Boards

BS	Board status, YELLOW
FS	Fieldbus status, GREEN

Table 24: BS = Board Status, Yellow

LED status	Description
OFF	Option board not activated
ON	Option board in initialization state waiting for activation command from the AC drive
Blinking fast (once per s)	Option board is activated and in RUN state <ul style="list-style-type: none"> Option board is ready for external communication
Blinking slow (once per 5 s)	Option board is activated and in FAULT state <ul style="list-style-type: none"> Internal fault of option board

Table 25: FS = Fieldbus Status, Green

LED status	Description
OFF	Fieldbus module is waiting for parameters from the AC drive <ul style="list-style-type: none"> No external communication
ON	Fieldbus module is activated <ul style="list-style-type: none"> Parameters received and module activated Module is waiting for messages from the bus
Blinking fast (once per s)	Module is activated and receiving messages from the bus
Blinking slow (once per 5 s)	Module is in FAULT state <ul style="list-style-type: none"> No messages from Master within the watchdog time Bus broken, cable loose or Master off line

7.4 LED Indications on OPTE6 Option Board

NOTE! Older versions of OPTE6 have the Board status (N) and CANopen run (M) LEDs in different order.

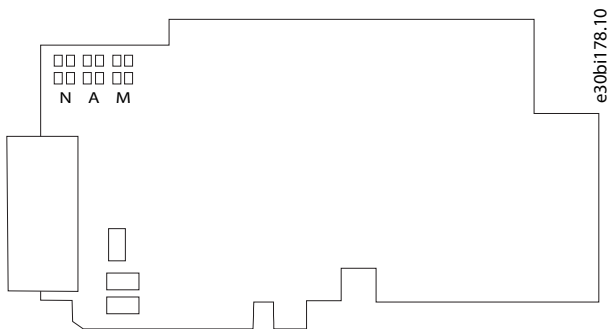

Illustration 49: LED Indications on VACON® OPTE6 Option Board

N	Board status	M	CANopen run
A	CANopen err		

Table 26: N = Board Status, Green

LED status	Description
OFF	Option board not activated
ON	Option board in initialization state waiting for activation command from the AC drive
Blinking fast (once per s)	Option board is activated and in RUN state <ul style="list-style-type: none"> Option board is ready for external communication

Table 27: A = CANopen err, Red

LED status	Description
OFF	No error
Blinking	Invalid configuration

LED status	Description
Single blink	At least one of the error counters of the CAN controller has reached or exceeded the warning level (too many error frames).
Double blink	A guard event (NMT slave or NMT master) or a heartbeat event (heartbeat consumer) has occurred.
Quadruple blink	An expected PDO was not received before the event timer elapsed.
ON	The CAN controller is bus-off.

Table 28: M = CANopen run, Green

LED status	Description
Blinking	The CANopen device is in the pre-operational state.
Single blink	The CANopen device is in the stopped state.
ON	The CANopen device is in the operational state.

7.5 LED Indications on OPTC6 Option Board

NOTE! LED N is unused.

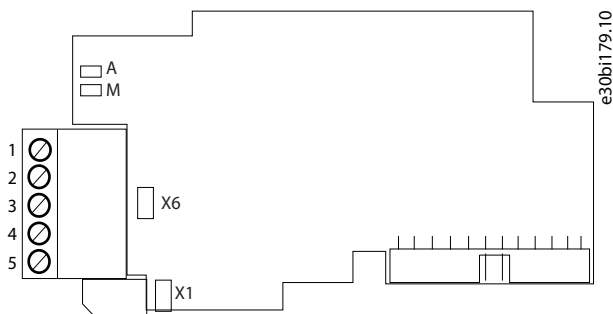

Illustration 50: LED Indications on VACON[®] OPTC6 Option Board

A	CANopen board status, Green
M	Fieldbus status, Green

Table 29: A = Board Status, Green

LED status	Description
OFF	Option board not activated
ON	Option board in initialization state waiting for activation command from the AC drive
Blinking fast (once per s)	Option board is activated and in RUN state <ul style="list-style-type: none"> Option board is ready for external communication

Table 30: M = Fieldbus status, Green

LED status	Description
OFF	Fieldbus module is waiting for parameters from the AC drive. No external communication
ON	Fieldbus module is activated. Parameters received and module activated.

LED status	Description
	Module is waiting for messages from the bus
Blinking fast (once per s)	Module is activated and receiving messages from the bus.
Blinking slow (once per 5 s)	Module is in FAULT state. No messages from Master within the watchdog time. Bus broken, cable loose or Master off line.

7.6 LED Indications on OPTC7 and OPTE7 Option Boards

The LED indications are the same on OPTC7 and OPTE7 option boards.

NOTE! Older versions of OPTE7 have the Network status (N) and Module status (M) LEDs in different order.

In OPTC7, the Node address (A) blinks the MAC ID of the unit while it is powered. In OPTE7, the Node address LED is not used.



Illustration 51: LED Indications on VACON® OPTE7 Option Board

N	Network status	M	Module status
A	Node status (not used)		

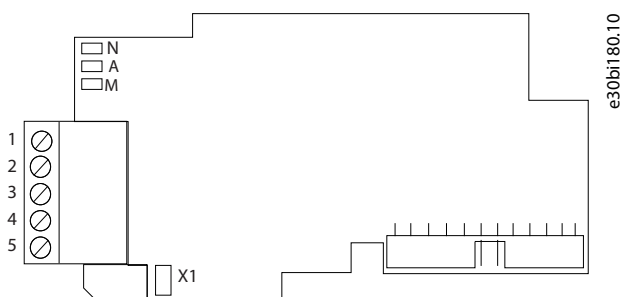

Illustration 52: LED Indications on VACON® OPTC7 Option Board

N	Network status	M	Module status
A	Node status		

Table 31: N = Network Status

LED status	Description
OFF	The OPTC7/E7 is not on-line <ul style="list-style-type: none"> The device has not completed the Dup_MAC_ID test yet. If the Module status LED is off, the device is not powered.
ON Green	The OPTC7/E7 is on-line and allocated to a Master
Blinking green	The OPTC7/E7 has passed the Dup_MAC_ID test, is on-line, but is not allocated to a master.
Blinking red	One or more I/O connections are in the Timed-Out state
ON Red	The OPTC7/E7 cannot communicate on the network (Duplicate MAC ID or Bus-off)

Table 32: M = Module Status

LED status	Description
OFF	There is no power applied to the OPTC7/E7.
ON Green	The OPTC7/E7 is operating normally
Blinking green	The OPTC7/E7 board is in Standby state or the device needs commissioning due to a missing, incomplete or incorrect configuration.
Blinking red	The option board has detected a Recoverable Fault.
Red	The option board has detected an Unrecoverable Fault.

7.7 LED Indications on OPTC4 Option Board

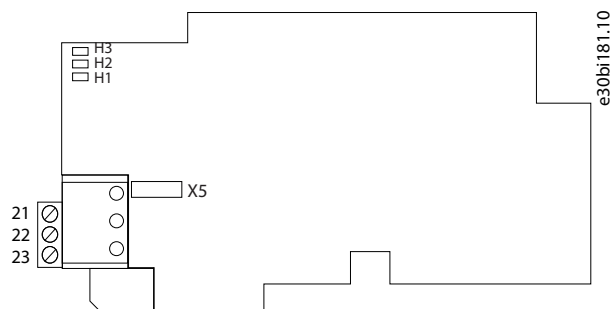

Illustration 53: LED Indications on VACON[®] OPTC4 Option Board

H3	Neuron service, GREEN	H1	Bus status, GREEN
H2	Board status, YELLOW		

Table 33: H3 = Neuron Service, Green

LED status	Description	State Code
OFF	Configured	4
ON	Applicationless and Unconfigured	3
Blinking	Unconfigured	2

Table 34: H2 = Board status, Yellow

LED status	Description
OFF	Option board not activated.
ON	Option board in initialization state waiting for activation command from the AC drive.
Single blink	At least one of the error counters of the CAN controller has reached or exceeded the warning level (too many error frames).
Blinking fast (once per s)	Option board is activated and in RUN state. Option board is ready for external communication
Blinking slow (once per 5 s)	Option board is activated and in FAULT state. Internal fault on option board.

Table 35: H1 = Bus status, Green

LED status	Description
OFF	Fieldbus module is waiting for parameters from the AC drive. No external communication.
ON	Fieldbus module is activated. Parameters received and module activated. Module is waiting for messages from the bus.
Blinking very fast for 5 s (once per 0.2 s)	Fieldbus module has received a wink request.
Blinking fast (once per s)	Module is activated and receiving messages from the bus.
Blinking slow (once per 5 s)	Module is in FAULT state. No messages from Net within the watchdog time. Bus broken, cable loose.

Index

A	VACON® 20.....	19,25
Additional resources.....	VACON® 20 X and 20 CP.....	29
B	J	
Bias resistors.....	Jumper settings	
Board layout	OPTE3/E5.....	39
OPTE3/E5.....	OPTE2/E8.....	39
OPTE2/E8.....	OPTC3/C5.....	41
OPTC3/C5.....	OPTC2/C8.....	45
OPTC2/C8.....	OPTCJ.....	45
OPTE6.....	OPTE6.....	48
OPTE7.....	OPTE7.....	48
OPTC6.....	OPTC6.....	50
OPTC7.....	OPTC7.....	52
OPTC4.....	OPTC4.....	53
Bus terminal.....		
C	M	
Cable requirements	Manual version.....	5
CAN type option boards.....		
LON type option boards.....	O	
Cabling	OPTC4 topology.....	53
Fieldbus.....		
Compatibility	P	
RS485-based serial bus.....	PROFIBUS DP.....	42
CAN bus-based.....	Purpose of the manual.....	5
VACON® 100 family internal RS485.....		
Connector pin.....	Q	
F	Qualified personnel.....	5
Fieldbus connectors.....		
Fieldbus grounding.....	S	
I	Safety.....	7
Installation	Strain relief.....	34
VACON® NXP and NXS.....	Symbols.....	7
VACON® 100 INDUSTRIAL and FLOW.....		
VACON® 100 X.....	T	
	Termination resistance.....	44

ENGINEERING
TOMORROW

Danfoss

Danfoss Drives Oy
Runsorintie 7
FIN-65380 Vaasa
www.danfoss.com

Danfoss can accept no responsibility for possible errors in catalogs, brochures and other printed material. Danfoss reserves the right to alter its products without notice. This also applies to products already on order provided that such alterations can be made without subsequential changes being necessary in specifications already agreed. All trademarks in this material are property of the respective companies. Danfoss and the Danfoss logotype are trademarks of Danfoss A/S. All rights reserved.

