

Data Sheet

# SSM Floor Heating Manifold

## Application



The SSM manifold is used for controlling water flow in under floor heating systems. Each tube of the floor heating system is connected to the manifold, thus making it possible to control water flow or heat supply to each room in the building individually.

The manifold consists of a supply and return manifold. The supply manifold includes possibility for individual shut-off of each circuit on flowmeter or shut-off valve. The return manifold is equipped with integrated Danfoss presetting valves securing optimal hydraulic balance in the system.

The valves can be controlled electronically by thermal actuators or act as self-acting units by means of remote temperature adjusters.

The manifold is supplied in modules of up to 12 outlets. Ball valves are available as an option for positive shut-off between manifold and system.

The SSM manifold is supplied with a manual air-vent and a purge valve.

## Ordering

Description	Type	Code no.
	Manifold set 2+2, with flowmeter	SSM-2F <b>088U0752</b>
	Manifold set 3+3, with flowmeter	SSM-3F <b>088U0753</b>
	Manifold set 4+4, with flowmeter	SSM-4F <b>088U0754</b>
	Manifold set 5+5, with flowmeter	SSM-5F <b>088U0755</b>
	Manifold set 6+6, with flowmeter	SSM-6F <b>088U0756</b>
	Manifold set 7+7, with flowmeter	SSM-7F <b>088U0757</b>
	Manifold set 8+8, with flowmeter	SSM-8F <b>088U0758</b>
	Manifold set 9+9, with flowmeter	SSM-9F <b>088U0759</b>
	Manifold set 10+10, with flowmeter	SSM-10F <b>088U0760</b>
	Manifold set 11+11, with flowmeter	SSM-11F <b>088U0761</b>
	Manifold set 12+12, with flowmeter	SSM-12F <b>088U0762</b>
		Manifold set 2+2
Manifold set 3+3		SSM-3 <b>088U0803</b>
Manifold set 4+4		SSM-4 <b>088U0804</b>
Manifold set 5+5		SSM-5 <b>088U0805</b>
Manifold set 6+6		SSM-6 <b>088U0806</b>
Manifold set 7+7		SSM-7 <b>088U0807</b>
Manifold set 8+8		SSM-8 <b>088U0808</b>
Manifold set 9+9		SSM-9 <b>088U0809</b>
Manifold set 10+10		SSM-10 <b>088U0810</b>
Manifold set 11+11		SSM-11 <b>088U0811</b>
Manifold set 12+12		SSM-12 <b>088U0812</b>

Ordering

	088U0752-62 SSM-F manifold with flow meter 088U0585 FHF-MB mounting bracket – set (off-set) 013G4186 Compression fittings for ALUPEX tubing, 16 x 2 mm Ball valve set (NO THERMOMETER)	SSM-FB	<b>088U0652</b>
		SSM-FB	<b>088U0653</b>
		SSM-FB	<b>088U0654</b>
		SSM-FB	<b>088U0655</b>
		SSM-FB	<b>088U0656</b>
		SSM-FB	<b>088U0657</b>
		SSM-FB	<b>088U0658</b>
		SSM-FB	<b>088U0659</b>
		SSM-FB	<b>088U0660</b>
		SSM-FB	<b>088U0661</b>
SSM-FB	<b>088U0662</b>		



Accessories

Description	Type	Code no.	
Mounting brackets — set (offset)	FHF-MB	<b>088U0585</b>	
	SSM-MB	<b>088U0595</b>	
Mounting brackets — set (straight)	SSM-MB	<b>088U0596</b>	
2 x ball valve 1" — for connection to manifold and for blocking of floor heating system	FHF-BV	<b>088U0822</b>	
1 x thermometer (0 °C to 60 °C) Ø 35 mm — for flow/return temperature measurement	FHD-T	<b>088U0029</b>	
Union, 1"	—	<b>088U0820</b>	
Replacement valve for manifold	—	<b>013G7376</b>	
Reducing Bush	FHF-R	<b>088U0584</b>	
Connection piece	FHF-C	<b>088U0583</b>	
Flowmeter	—	<b>088U0819</b>	
	Thermal actuator, 24V, NC, Danfoss RA connection to valve	TWA-A	<b>088H3110</b>
	Thermal actuator, 230V, NC, Danfoss RA connection to valve	TWA-A	<b>088H3112</b>
	Thermal actuator, 24V, NC, with end switch, Danfoss RA connection to valve	TWA-A	<b>088H3114</b>

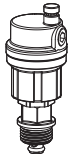
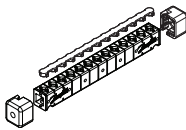
Accessories

	Stuffing box for manifolds	DZR	<b>013G0554</b>
	Automatic air ventilation valve	SSM-AV	<b>088U0945</b>
	Insulation capsule for SSM manifold	SSM-I	<b>088U0824</b>

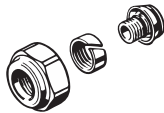
Compression fittings

Description	Type, mm	Code no.
 <p>Compression fittings for PEX tubing in accordance with DIN16893 &amp; DIN 4726.</p> <p>Max working pressure: 6 bar Test pressure: 10 bar Max. flow temperature: 95 °C G 3/4" internal thread</p> <p>Max. flow temperature given by the tube manufacturer must not be exceeded.</p>	12 × 2	<b>013G4152</b>
	13 × 2	<b>013G4153</b>
	14 × 2	<b>013G4154</b>
	15 × 2,5	<b>013G4155</b>
	16 × 1,5	<b>013G4157</b>
	16 × 2	<b>013G4156</b>
	16 × 2,2	<b>013G4163</b>
	17 × 2	<b>013G4162</b>
	18 × 2	<b>013G4158</b>
	18 × 2,5	<b>013G4159</b>
	20 × 2	<b>013G4160</b>
	20 × 2,25	<b>013G4093</b>
20 × 2,5	<b>013G4161</b>	
 <p>Compression fittings for ALUPEX tubing in accordance with DIN16893 &amp; DIN 4726.</p> <p>Max working pressure: 6 bar Test pressure: 10 bar Max flow temperature: 95 °C G 3/4" internal thread</p> <p>Max flow temperature given by the tube manufacturer must not be exceeded.</p>	12 × 2	<b>013G4182</b>
	14 × 2	<b>013G4184</b>
	15 × 2,5	<b>013G4185</b>
	16 × 2	<b>013G4186</b>
	16 × 2,25	<b>013G4187</b>
	18 × 2	<b>013G4188</b>
	20 × 2	<b>013G4190</b>
	20 × 2,25	<b>013G4093</b>
20 × 2,5	<b>013G4191</b>	

**Capacity/commissioning**

The pre-setting of the manifold valves determines the flow in the floor heating tubes and is therefore an important factor for obtaining optimal hydraulic balance in the system.

A correct hydraulic balance is important if optimal comfort shall be achieved with a minimum of energy consumption and is easily carried out following the example shown below.

**Example**

Room 1:	1. Determine longest tube/largest room	25 m <sup>2</sup>
	2. Desired cooling (Δt)	5 °C (typical)
	3. Determine heat requirement for the room	50 W/m <sup>2</sup>
	4. Conversion factor	1,16
	5. Calculation of flow for the room	$Q \text{ (l/h)} = \frac{50 \text{ W/m}^2 \times 25 \text{ m}^2}{5 \text{ °C} \times 1,16} = 216 \text{ l/h}$

Room 2:	6. Determine area for the next room	15 m <sup>2</sup>
	7. Calculation of flow for the room (Δt and heat requirement is assumed identical for the rooms in this case)	$Q \text{ (l/h)} = \frac{50 \text{ W/m}^2 \times 15 \text{ m}^2}{5 \text{ °C} \times 1,16} = 129 \text{ l/h}$

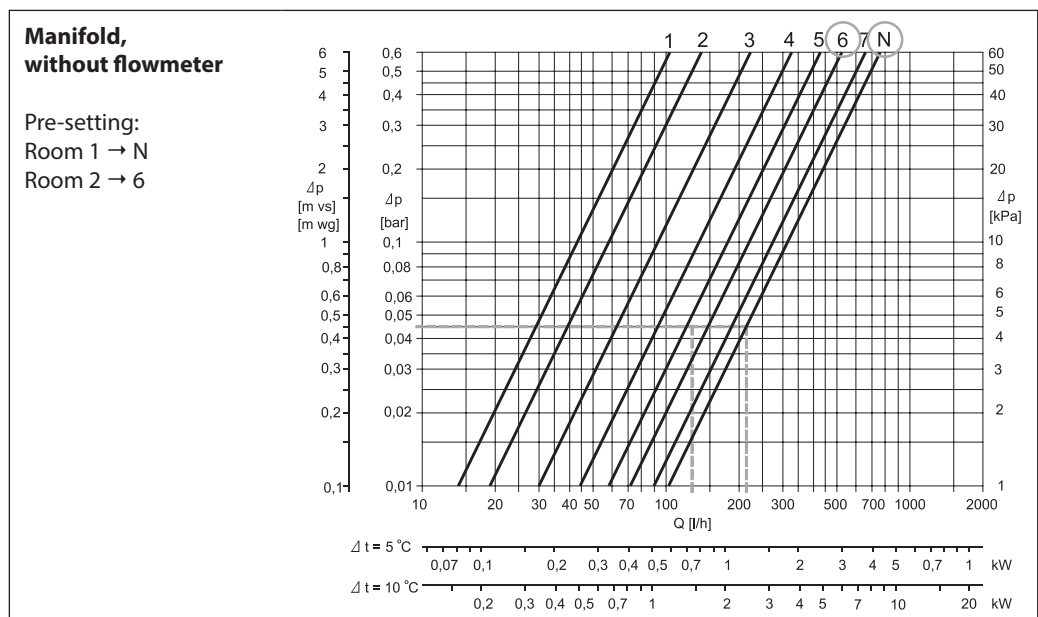
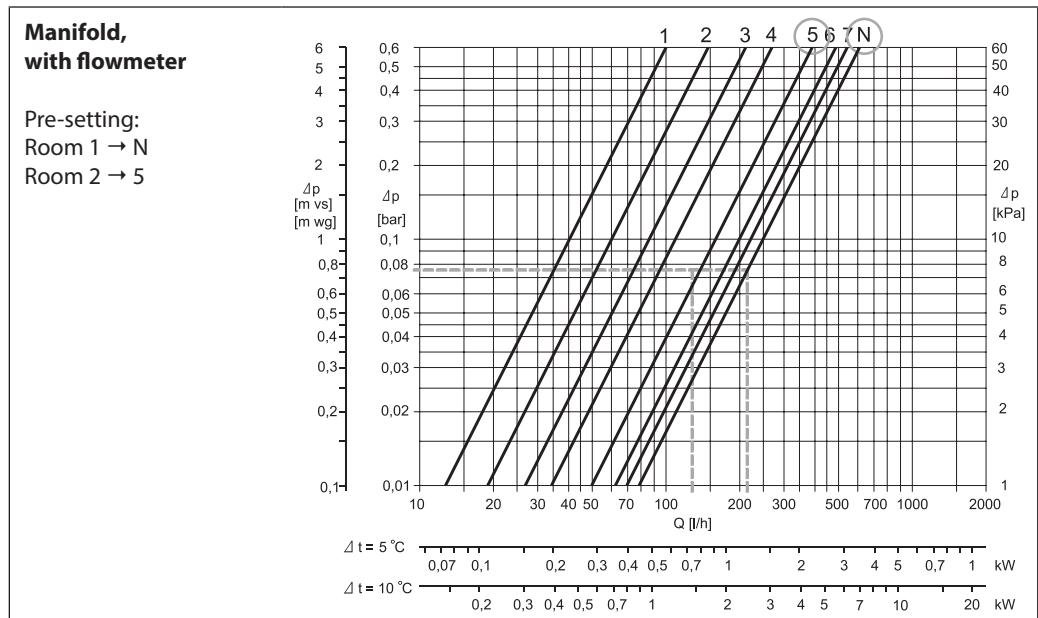

**Presetting the manifold valves**

The diagram shows the capacities for each heating circuit at different presettings of the manifold valves.

Based on the above calculations and capacity diagram each manifold valve is preset by rotating the red ring until the correct value on the ring is in-line with the sight mark on the valve.

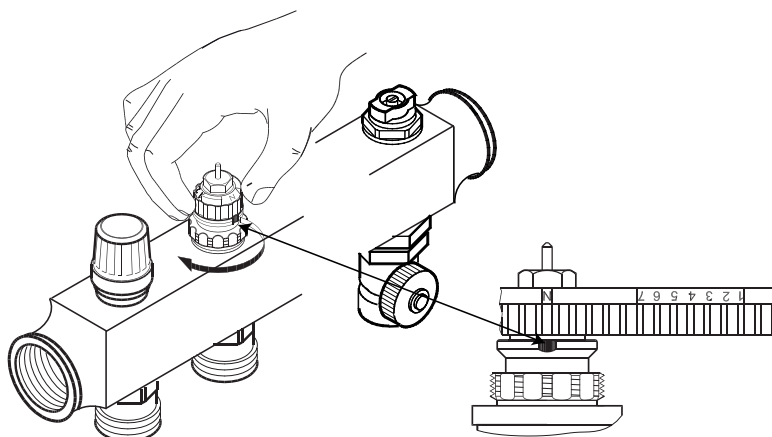

**Operation conditions**

	Supply manifold with flowmeter	Supply manifold without flowmeter
Max differential pressure	0,6 bar	0,6 bar
Max working pressure	6 bar	10 bar
Max test pressure	10 bar	16 bar
Max flow temperature	60 °C	90 °C

**System layout**

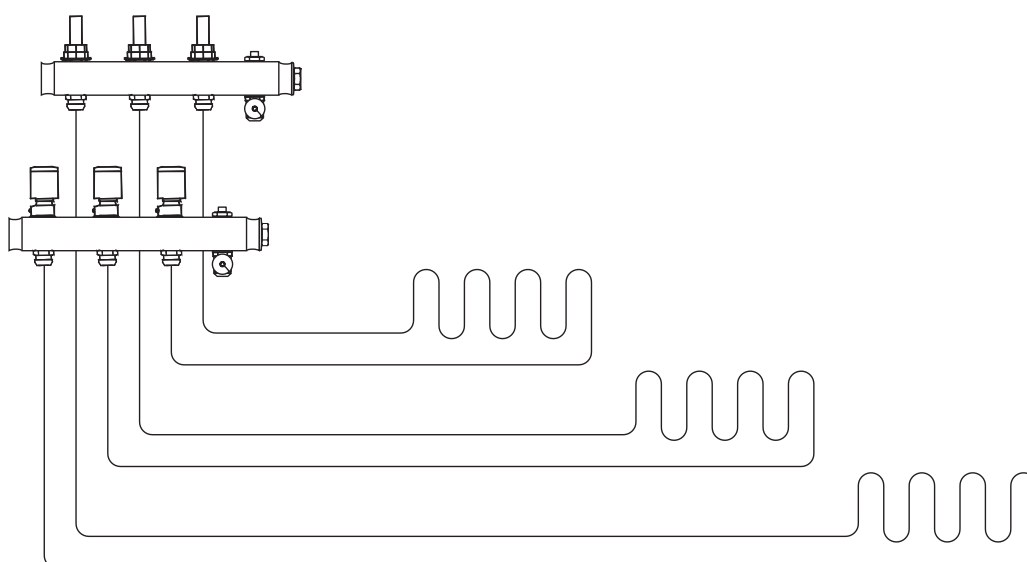

Dimensions

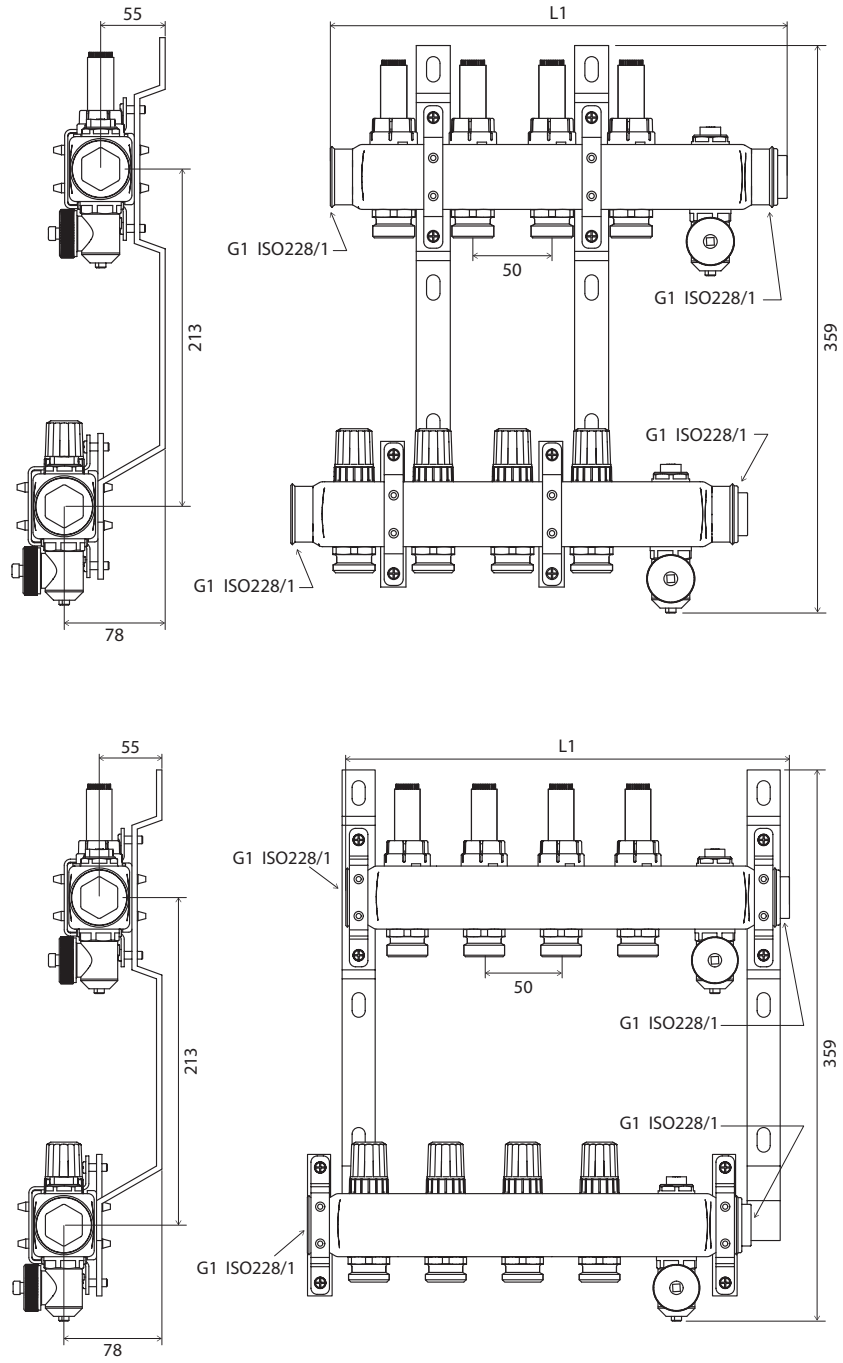

with **088U0585** brackets set

Type	2+2	3+3	4+4	5+5	6+6	7+7	8+8	9+9	10+10	11+11	12+12
L1 (mm)	190	240	290	340	390	440	490	540	590	640	690

Dimensions

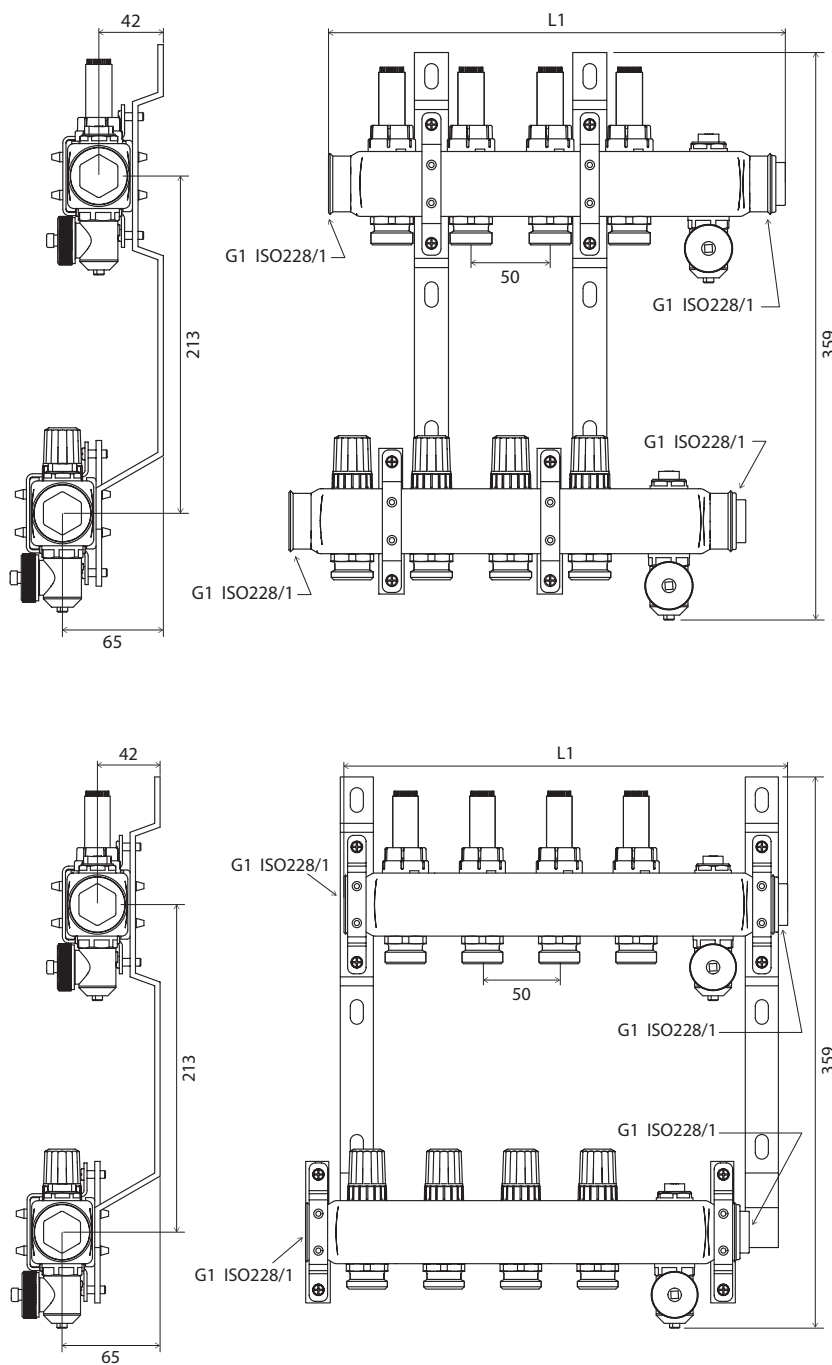

with **088U0595** brackets set

Type	2+2	3+3	4+4	5+5	6+6	7+7	8+8	9+9	10+10	11+11	12+12
L1 (mm)	190	240	290	340	390	440	490	540	590	640	690

**Dimensions**

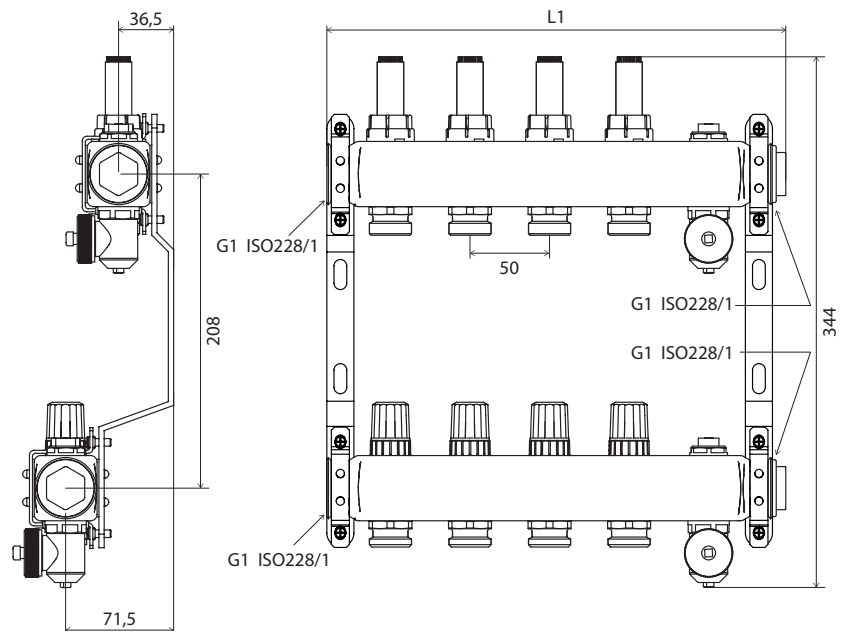
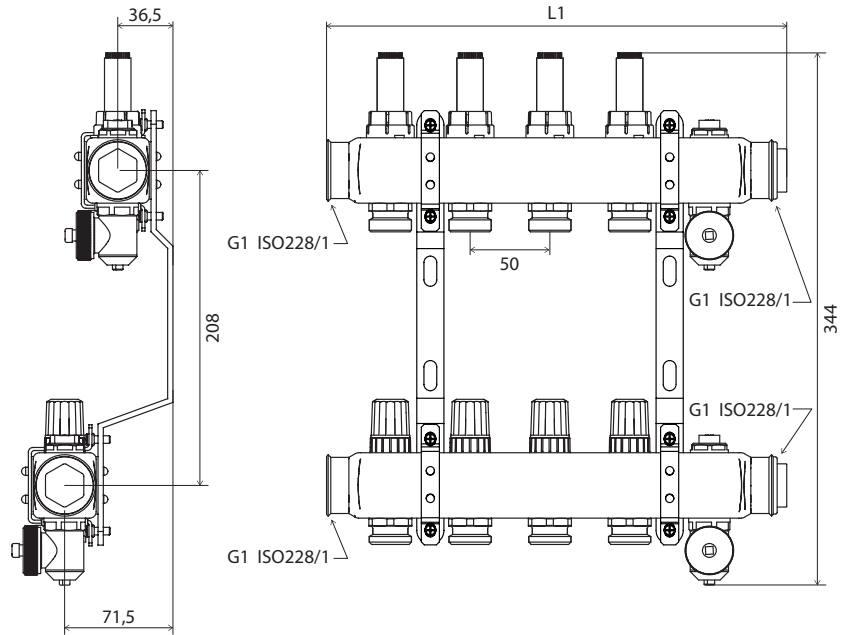

with **088U0596** brackets set

Type	2+2	3+3	4+4	5+5	6+6	7+7	8+8	9+9	10+10	11+11	12+12
L1 (mm)	190	240	290	340	390	440	490	540	590	640	690

**Danfoss A/S**

Climate Solutions • danfoss.com • +45 7488 2222

Any information, including, but not limited to information on selection of product, its application or use, product design, weight, dimensions, capacity or any other technical data in product manuals, catalogues descriptions, advertisements, etc. and whether made available in writing, orally, electronically, online or via download, shall be considered informative, and is only binding if and to the extent, explicit reference is made in a quotation or order confirmation. Danfoss cannot accept any responsibility for possible errors in catalogues, brochures, videos and other material. Danfoss reserves the right to alter its products without notice. This also applies to products ordered but not delivered provided that such alterations can be made without changes to form, fit or function of the product.

All trademarks in this material are property of Danfoss A/S or Danfoss group companies. Danfoss and the Danfoss logo are trademarks of Danfoss A/S. All rights reserved.