

ENGINEERING  
TOMORROW

*Danfoss*

Service guide

# MicroChannel Heat Exchangers

MCHE

## Installation and Maintenance Guide

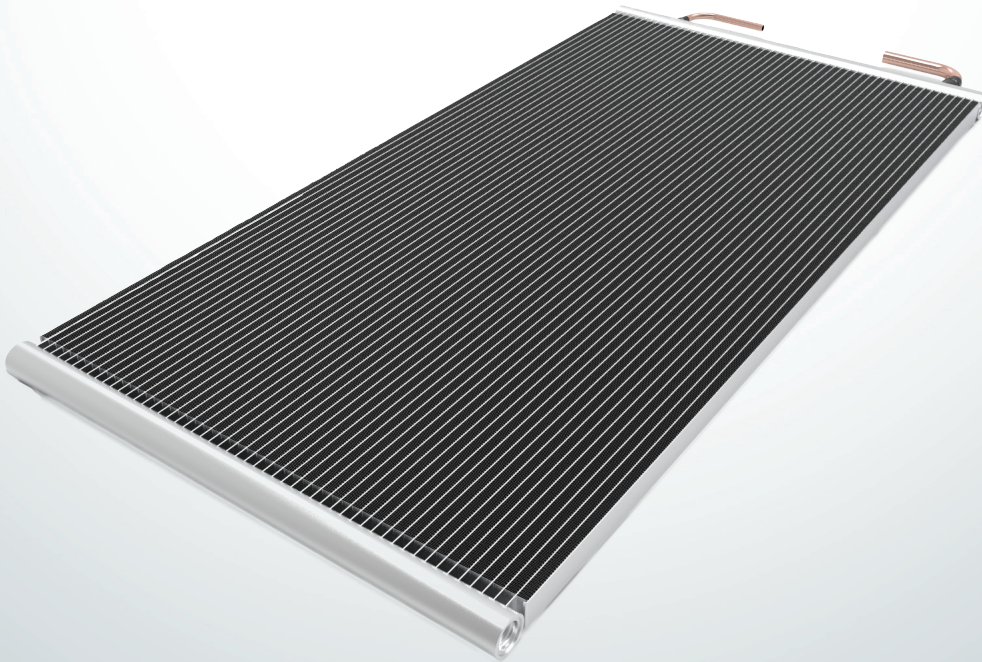

**Table of Contents**

Contents	
Table of Contents .....	2
1. Introduction .....	3
1.1 General .....	3
1.2 General .....	3
2. Storage and working environments .....	4
2.1 Storage .....	4
2.2 Handling .....	4
2.3 Bending procedure .....	4
2.4 Bending Time and Temperature Limitation .....	4
3. Installation .....	5
3.1 Pass arrangement .....	5
3.2 Fan location and size .....	5
3.3 Coil mounting against thermal expansion .....	6
3.5 Prevention of galvanic corrosion .....	7
3.6 Vibration .....	8
4. Leak repair .....	8
5. Coating .....	9
6. Maintenance of MicroChannel Heat Exchangers (MCHE) .....	9
7. Coolant Application .....	11
7.1 Definition .....	11
7.2 Requirement .....	11
7.3 Leak Test .....	12
7.4 Note .....	12

## 1. Introduction

### 1.1 General

This guide is for installation and maintenance of Danfoss Microchannel Heat Exchangers (MCHEs). We recommend that you read this manual carefully before commencing any work. Danfoss is not responsible or liable for any damage caused by failure to comply with the instructions in this manual and/or due to incorrect installation, operation and maintenance of MCHEs.



**All personnel being responsible for operation and maintenance of the heat exchanger unit must read and fully understand these instructions before:**

- Transportation of the MCHE unit
- Lifting the unit
- Installing the MCHE unit
- Servicing the MCHE unit
- Maintaining the MVHe unit

### 1.2 General

---



Indicates something to be noted by the reader

---



Indicates a situation which will or could result in personal injury and/or damage to the MCHE

---

## 2. Storage and working environments

### 2.1 Storage



Microchannel heat exchangers should be stored indoors in a dry and clean environment. The storage temperature range is -40 °C to 121 °C (-40 °F to 250 °F).

Metal chips, and/or copper or steel dust can cause galvanic corrosion, so storage and installation areas must remain clean and separate from machining or welding areas. Use separate tools and/or keep tools clean.

To minimize potential damage, we recommend that you keep MCHEs in their original packaging until they are installed in the air conditioning or refrigeration equipment.

Improper storage and stacking of MCHEs can cause premature corrosion or deformation and will reduce MCHE's life. Extra care should be taken when storing MCHEs!

Refrigerants used in MCHE shall comply with AHRI Standard 700.

The maximum operating pressure shall not exceed the value shown on the Label of MCHE.

### 2.2 Handling

Compared to tube & fin coils, microchannel heat exchangers are relatively light, the fins are harder to bend and they are less likely to cut fingers. The combination of these features makes MCHEs easier to handle than tube & fin coils. However, the overall coil assembly is made of soft aluminum, so it is susceptible to deformation (Fig.1)

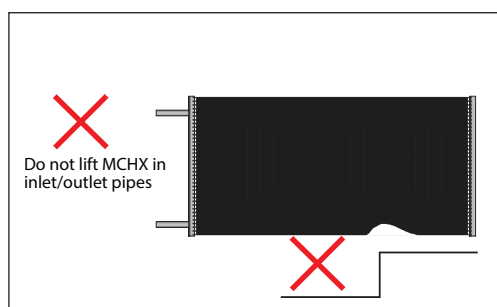

Fig. 1 Handling attentions



Never lift a MCHE by the inlet and outlet tubes as it might result in dimensional deviation or worse yet, the initiation of a crack that can later result in a leak.

Do not hit or drop MCHE on edges.

The MCHE is constructed of soft aluminum therefore, dropping, striking, placing heavy objects on top of, or stepping on any part of the heat exchanger will likely cause a deformation. If

the coil becomes slightly deformed or bowed, it is possible to flatten them back out by laying them concave side down on a flat hard surface and applying pressure via a large heavy flat plate (say 3-4 square feet of 1/2" non-metallic sheet, such as plywood or plastic, with a couple of handles attached). This procedure works for bowed coils with flush fins, but not for local fin protrusions.

### 2.3 Bending procedure

The same bending machines can be used for MCHE and tube & fin heat exchangers. In order to optimize costs associated with shipping and packaging, we recommend that MCHEs be shipped flat and formed at the customer's location.

#### Bending Radius:

The minimum bend radius required to achieve acceptable manufacturing yields is a function of the microchannel tube, fin, and alloy, the overall capabilities of the bending equipment including, fixturing, bending speed and bending length.



NOTE: Conducting trial bending runs of the specific coil and configuration are recommended to verify. In general, tighter radius, thicker tubes and longer bend lines are harder to bend. Use a larger radius if possible.

Recommended minimum bending radii (as determined by factory tests under favorable conditions) are shown in Table 1 for different microchannel tubes and fins. Consult with Danfoss for the tubes not listed. Do not arbitrarily extrapolate or interpolate the values.

### 2.4 Bending Time and Temperature Limitation

No bending time and temperature limitation on BARE MCHE. While for coated MCHE, long warehoused time and low temperature shall reduce the epoxy coating's elasticity may result coating cracking. To assure optimum corrosion protection and coating layer integrity on formed MCHE requires:

- Coils shall be bent within 6 months of coating,
- Metal and coating temperature shall be greater than 16 °C (60 °F) at time of bending,
- Coating shall be protected from abrasion, gouges, and impact before and during the bending process,
- Inspect coil geometry and appearance after bending to conformity drawings and specification requirement.

**Recommended bending radii**

MC Tube	Structural parameters		Material	Min. recommended bending R	
	Tube (Wmm*Hmm*Port#)	Fin (Hmm*Gage mm)		mm	in
C116	16*1.3*16	8.1*0.08	3102 Tube + 3003MOD Fin	90	3.5
C120	20.6*1.3*20			140	5.5
C125	25.4*1.3*26			200	7.87
C225	25.4*2.0*20			220	9.45

Table 1



Consider the following during bending: MCHEs are constructed of soft aluminum and are susceptible to deformation during handling. Prior to bending operation, make sure the MCHE is flat, square and undamaged. Consider a sizing operation to ensure this.

Make sure the coils are loaded into the bender in a way that keeps them flat square and undamaged.

Keep the flat tubes perpendicular to the spindle while bending the coil.

Clamp the coil during the bending process, being careful not to crush it.

Slower bending speeds will often yield better results.

Vertical spindle bending machines are often set up so that the microchannel coil ends up sliding along the table with all its weight supported by the header ends and/or the bottom dead tube.

During the bending operation, do not let one end of the coil become cantilevered off the edge the table, because this can cause the coil to droop with the tubes being non-perpendicular to the spindle, resulting in corkscrewing or reduced bend quality and/or consistency. Note that with some benders, a portion of the supporting table will drop down during bending, creating opportunities for cantilever loads and improper bending.

- Bending multi-bend coils on a horizontal spindle bender can cause cantilevered loads resulting from the dead weight of the unsupported bent legs. As an example, a coil with three (3) bends, depending on fixturing, may result in the load of the first 75% of the coil being transferred into the remaining coil leg, possibly causing poor bend quality and/or permanent deformation. Bending challenges are greater with MCHE's than similar fin and tube coils, requiring proper fixturing.

**3. Installation**

**3.1 Pass arrangement**

Carefully identify the locations of the inlet and outlet tubes. Microchannel condensers is often designed with multiple passages (parallel flow) that have fewer tubes in each successive pass (Fig. 2)

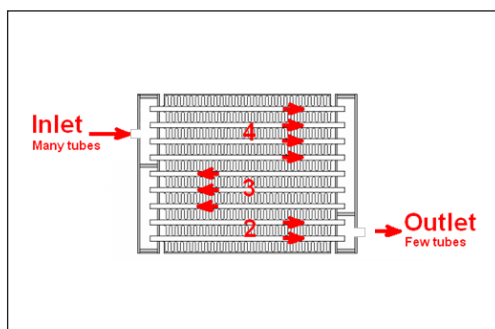

Fig. 2 MCHE passes distribution

Danfoss MCHEs include a small notch in both headers to indicate that this is the bottom of the heat exchanger. Additionally, a product label is placed on the outermost tube (unless specified elsewhere by the customer), indicating the top of the heat exchanger.

Incorrectly connecting the inlet and outlet tubes of a MCHE will likely result in excessive refrigerant side pressure drop and poor heat transfer.

**3.2 Fan location and size**

Air distribution may have an influence on the performance of the MCHE. For good air distribution choosing a fan with proper fan diameter and keeping a constant distance between the coil and the fan is desirable. We recommend selecting a fan diameter that is as close as possible to the smallest of MCHE height and length. The MCHE is recommended to locate on the surface which have relative uniform air velocity from the fan. (Fig.3).

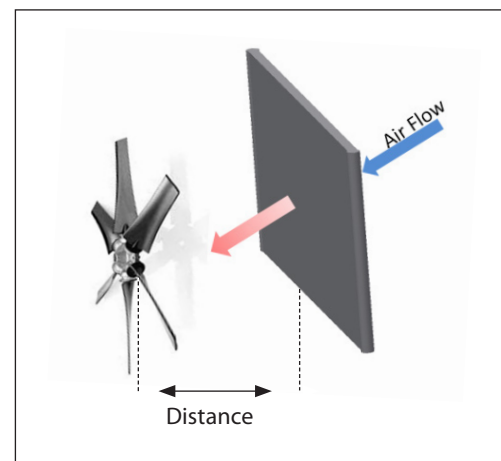

Fig. 3 Fan and coil

### 3.3 Coil mounting against thermal expansion

Thermal expansion of aluminum is higher than most other metals. Frequent thermally induced stress could shorten the life of the micro channel heat exchanger (Fig.4)

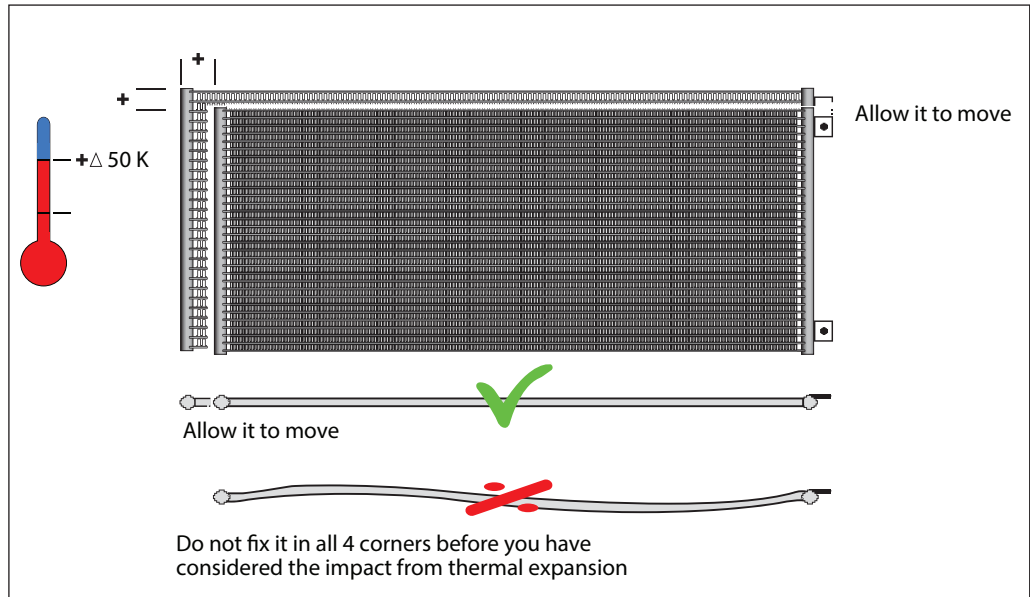

Fig. 4 Coil mounting for MCHE

To avoid the risk of thermal expansion, a micro channel heat exchanger must be mounted with brackets that allow some flexibility of movement. Mounting methods as indicated in Figures 5a and 5b are recommended.

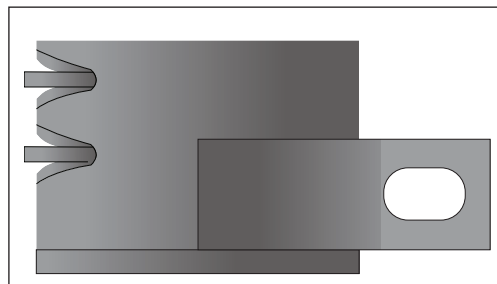

Fig. 5a Mounting by bracket

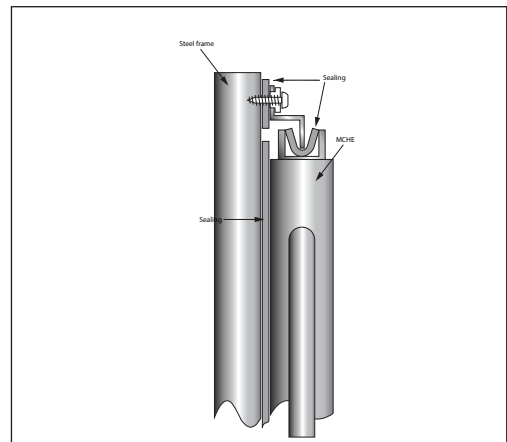

Fig. 5b Mounting by end plate

Inlet/outlet connections are not designed to be used as handles, support mating tubes, resist thermal expansion, or be forced into position with mating tubes during assembly, etc. In particular:  
 Inlet/outlet connections must be assembled & supported so that the brazed joints are not exposed to stress/tension. (Fig.6) Mating tubes should be pre-bent to avoid damaging or collapsing the MCHE's copper/aluminum inlet/outlet tubes and/or aluminum transition cups. Mating tubes should be configured so that no bending or forcing is required during installation.

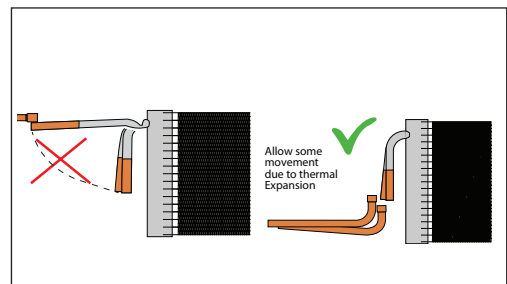

Fig.6 Inlet/Outlet connection attentions

Plastic heat shrink tubing prevents galvanic corrosion in the MCHE's copper to aluminum joint by keeping moisture from entering the area. A minimum of 70mm length from the Cu/Al joint to the connection point is required to protect the Cu-Al brazing joint and plastic shrink tube from excessive heat during the brazing process. When brazing copper piping to the MCHE, it is recommended to use dry nitrogen purging along with a heat sink and/or wrapping the copper stub tube with a wet cloth to protect the Cu/Al joint and heat shrink tubing from excessive heat. This also applies to microchannel heat exchangers with aluminum inlet/outlet tubes. Depending on the location of the connections relative to the heat exchanger, a heat shield may be required to protect the MCHE's tubes and fins from the brazing torch. The recommended pipe length "L" after the brazing joint should be greater than or equal to 70mm as shown in the picture below (Fig.7).

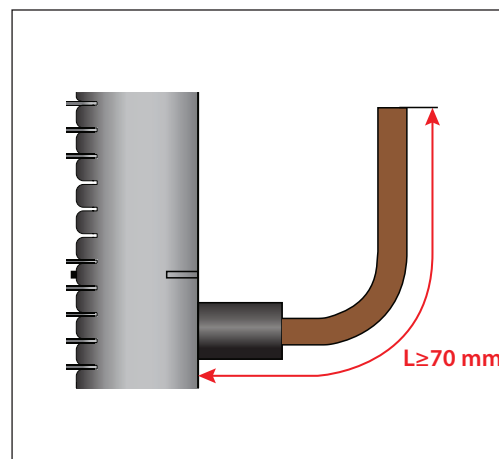

Fig. 7 Recommended length of inlet/outlet connections

### 3.4 Elimination of gaps

To maximize heat transfer performance, gaps should be eliminated on both sides of the face of the MCHE. Gaps should also be eliminated on the top, bottom and sides of the MCHE so that all fan induced air is directed over the coil surface. This can be accomplished with sealing strips as shown in Fig. 8.

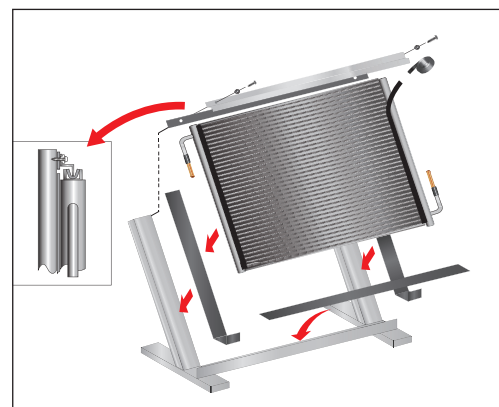

Fig. 8 Typical installation

### 3.5 Prevention of galvanic corrosion

Aluminum is a chemically reactive metal and will corrode when combined with most metals that are used today in industrial manufacturing. To avoid any galvanic corrosion, it is necessary to separate Al and other metals. The best way to prevent galvanic corrosion is to use plastic/rubber/foam as a means to isolate the aluminum coil from dissimilar metals (Fig 8)



### 3.6 Vibration

Vibration that exceeds a specific range may cause the failure of MCHE. To avoid failure due to vibration:



Make sure vibration level meet requirements as in table 2.

Name	Parameter
Amplitude/mm	≤0.15 (peak to peak is 0.3 mm)
Acceleration/m.s <sup>-2</sup>	≤20

Table 2 The allowable vibration ranges

It is recommended to test on points that in the area within 10mm to the end of the connection tube (Fig 9)

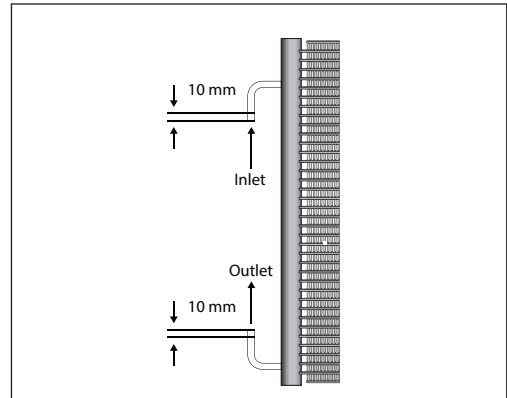

Fig. 9 Recommend test points of vibration

Best practices in the case to prevent the MCHE from the influence of vibration is using rubber washers on the brackets or rubber supports on the manifolds (fig.10a&10b)



Fig. 10a Rubber washer

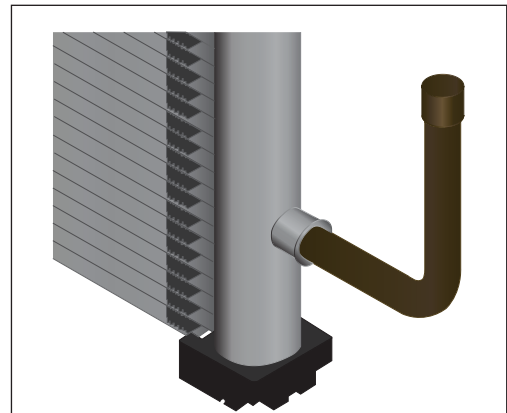

Fig. 10b Rubber support

### 4. Leak repair

Not recommends to repair MCHE refrigerant leak in the field. Danfoss recommends replacement of the MCHE in the event that a leak develops It due to a defect, mechanical damage or premature corrosion.



## 5. Coating

Coating of a heat exchanger could increase corrosion resistance in certain applications and/or environmental conditions such as coastal or industrial areas, as well as situations with stagnant water or extreme wet conditions. Danfoss approved coating systems provide a controlled process for the cleaning, rinsing, and the application of the coating material with full and even coverage. Untested coating systems may not adhere properly to the aluminum surface due to the flux residue left on the aluminum surface after brazing. In addition, any small area not covered by the coating could potentially pose a risk of failure due to corrosion. Thermal performance may also be reduced by improper application of the coating resulting in clogging or bridging between the fin and louvers



### WARNINGS

Field applied coatings are not recommended for brazed aluminum MicroChannel heat exchangers. Danfoss MicroChannel heat exchangers must NOT be coated using any other coating, but the ones specifically approved by Danfoss, such as certain qualified e-coating (epoxy based electrophoretic coating) suppliers or similar high-quality coating technologies. Coating of a coil using a supplier or coating process not approved by Danfoss voids the product warranty. It may also reduce the lifetime and/or the performance of the MicroChannel heat exchanger. Consult your Danfoss Sales & Application representative for more information.

## 6. Maintenance of MicroChannel Heat Exchangers (MCHE)

Frequent servicing is essential to maintaining the required MCHE performance. For every installed Danfoss MCHE, service records must be documented.



### CAUTION

Prior to servicing MCHE, be sure to disconnect the power supply and use lock-out methods to prevent the power from accidentally being turned on.

### Filters

Danfoss recommends the use of air filters on the frontal face of the MCHE to lower the deposition of rain water and other contaminants that can collect on the surface of the tubes.

### Shut down periods

During periods when the MCHE is not operated for longer than a week, the MCHE must be completely cleaned following the cleaning procedure. This practice must also be performed during short shut-down periods where corrosive deposits accumulate on the MCHE.

### Reversible fan motor

Danfoss recommends the function to reverse the direction of condensing fan motor for several minutes every day. It could help to blow off excess dust, dirt, debris and remaining water from the condensing coil.

### Cleaning Procedure

Relative to tube & fin heat exchangers, Micro-Channel heat exchanger coils tend to accumulate more dirt on the surface of the coil and less dirt inside the coil, making them easier to clean. Follow the steps below for proper cleaning:

#### Step 1: Remove and clean the dust screen

Remove the dust screen outside the MCHE coils or fans if the unit has. Clean the dust screen independently by suitable equipment e.g. high pressure water guns, vacuum cleaners or brushes.

#### Step 2: Remove surface debris

Remove surface dirt, leaves, fibers, etc. with a vacuum cleaner (preferably with a brush or other soft attachment rather than a metal tube), compressed air blown from the inside out, and/or a soft bristle (not wire!) brush. Do not impact or scrape the coil with the vacuum tube, air nozzle, etc

#### Step 3: Rinse

Rinse the coil by following procedure:

1. Rinse the coil by approved MCHE cleaner first, or rising by water directly;
2. Waiting for 5 minutes;
3. Wash the coil by water;

Adjust the angle of gimbaled nozzle and insert it through fans. Using an extension rod if the nozzle cannot reach the bottom side. Preferably cleaning the coils from the inside-out and top to bottom (see figure 3), running the water through every fin passage until it comes out clean. The fins of MicroChannel coils are stronger than traditional tube & fin coil fins but still need to be handled with care. Do not hit the coil with the hose. We recommend placing your thumb over the end of the hose to obtain a gentler spray and reduce the possibility of impact damage. Please **PAY MORE ATTENTION** when using a pressure cleaning equipment to prevent damage.

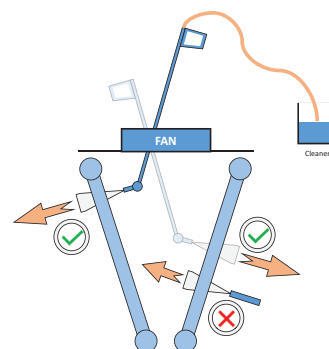

Figure 3

Highest pressure of cleaning equipment shall not exceed 15 bar, and tentatively move the cleaning equipment from far to near to prevent damage.

- KEEP the outlet of washer away from coil for at least 10cm, see figure 4;
- KEEP the water gun perpendicular to the coil surface and the angle error shall less than 20°, or  $\pm 40^\circ$  if the distance from washer to coil is more than 30cm, see figure 4;
- Water outlet angle for high pressure cleaning equipment shall over 15°, see figure 5. NEVER use direct water jet mode for cleaning.

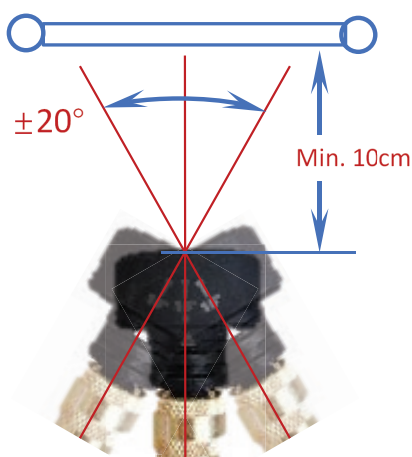

Figure 4



Figure 5

Warranty claims related to cleaning damage, especially for incorrect pressure washing operation, or corrosion resulting from applying non-recommended cleaners, will NOT be honored.

**Step 4: Blow dry**

Depending on the installation and fin geometry, MicroChannel heat exchangers could possibly retain more water compared to traditional tube & fin coils. It is advised to blow off or vacuum out the residual water from the coil to speed up drying and prevent pooling.

Danfoss recommends a quarterly cleaning of the coils, as the minimum. The cleaning frequency should be increased depending on the level of dirt/dust accumulation and the environment (e.g., coastal areas with chlorides and salts) or industrial areas with aggressive substances.

**Step 5: Install the dust screen back**  
Install the dust screen back if the unit has this component.

**! WARNING**

Field applied coatings are not recommended for brazed aluminum MicroChannel heat exchangers. Danfoss MicroChannel heat exchangers must NOT be coated using any other coating, but the ones specifically approved by Danfoss, such as certain qualified e-coating (epoxy based electrophoretic coating) suppliers or similar high-quality coating technologies. Coating of a coil using a supplier or coating process not approved by Danfoss voids the product warranty. It may also reduce the lifetime and/or the performance of the MicroChannel heat exchanger. Consult your Danfoss Sales & Application representative for more information

## 7. Coolant Application

### 7.1 Definition

7.1.1 Water: treated water without any chemical compound added.

7.1.2 Glycol Solution: Refers to commercially available glycol coolants that include inhibitors, pH buffers, and compounds for biological integrity. It is not a pure glycol solution.

7.1.3 Coolant: refer to:

7.1.3.1 Water solution: Treated water with added inhibitors, pH buffers, and compounds for biological integrity.

7.1.3.2 Glycol solution: As defined above.

### 7.2 Requirement:

#### 7.2.1 For coolant:

To ensure the long operating lifespan for microchannel coil, the following conditions for coolant shall be in place:

- PH: Ideal case pH neutral at 20-25°C (7.5 < pH < 8.5).

- Ammonium NH<sub>4</sub><sup>+</sup> < 2 mg/L.

- Cl- chloride ions < 10 mg/L. (water temp. < 65°C)

- Sulfate ions SO<sub>4</sub><sup>2-</sup> < 30 mg/L.

- Fluoride ions < 0.1 mg/L.

- No Fe<sup>2+</sup> and Fe<sup>3+</sup> ions if non negligible levels of dissolved oxygen present (>5mg/L),

Fe<sup>2+</sup> and Fe<sup>3+</sup> ions < 5mg/L if dissolved oxygen < 5mg/L.

- Zn ions is not allowed (ethylene glycol solution application).

- Dissolved silicon < 1mg/L

- Water hardness: > 0.5 mmol/L. Value between 1 and 2.5 mmol/L is recommended.

- Total alkalimetric title (TAC) ≤ 100 mg/L.

- Specific resistance – electric conductivity: > 30 Ohm.m is expected. For electric conductivity value in the order of 20 to 60 mS/m is expected.

#### Notes:

- **Dissolved Oxygen:** No sudden changes in water oxygenation conditions are expected.
- **Corrosion Inhibitor:** Adding a corrosion inhibitor is necessary to ensure coil protection, such as those based on monopropylene glycol or sodium molybdate.
- **Coolant Velocity:** High coolant velocity may cause corrosion of microchannel tubes. It is recommended that the tube-side coolant velocity not exceed 1.5 m/s to prevent this issue.
- **Filtration:** A filter with greater than 20 mesh is recommended to prevent tube blockages.

#### 7.2.1.1 Specific notes for water solution

- Treated water with the appropriate inhibitor is an acceptable solution. The inhibitor should provide protection for the entire material system. Different material systems may require different inhibitors. For instance, inhibitors for copper and iron systems will differ from those needed for systems containing aluminum, copper, and iron.
- In addition to inhibitors, pH buffers and compounds for biological integrity should also be added.
- Before mixing with inhibitors, pH buffers, and compounds for biological integrity, the water should meet or exceed the 3rd-grade water quality requirements as per ISO 3696-1995. Reverse osmosis water can achieve this quality. It is advisable to consult a local water treatment company for expertise.

#### 7.2.1.2 Specific notes for glycol solution

##### 7.2.1.2.1 Glycol solution concentration:

Glycol solution concentration is determined by the minimum freeze temperature of the mixture, but other factors should also be considered to define the “right” glycol concentration in a closed loop. Increasing glycol solution concentration reduces heat transfer, so a comprehensive approach is necessary. The following guidelines apply to all glycol circuits:

- The suggested minimum glycol concentration is always above 20%, even if not required by the freezing temperature.
- A suitable inhibitor should be chosen for the entire material system. For instance, inhibitors for copper and iron systems will differ from those needed for systems containing aluminum, copper, and iron.

##### Reasons for these guidelines:

- **Corrosion Protection:** Glycol solution is not a corrosion inhibitor at low concentrations. Below 20%, there are not enough inhibitors to preserve pipe integrity. Glycol solutions are designed to guarantee corrosion protection at concentrations above 20%.
- **pH Buffering:** Oxidation of glycol (e.g., exposure to high temperatures) forms acids that can potentially damage pipes. The correct minimum glycol concentration will buffer the solution against these acids by increasing its pH.

- **Biological Integrity:** At concentrations above 20%, glycol inhibits the proliferation of most bacteria and fungi. Glycol is biostatic, not biocidal. At very low concentrations (below 1%), both ethylene and propylene glycol can act as nutrients for bacteria, leading to rapid bacterial growth. At concentrations between 1% and 20%, some bacteria can survive with limited growth, especially at moderate temperatures.

### 7.3 Leak Test

- It is recommended to use nitrogen for the leakage test of the entire unit before shipment instead of water. This is because residual water trapped in the system after the leak test can cause local corrosion before commissioning, depending on the water quality used and the duration between shipment and commissioning.

### 7.4 Note

It is important to note that these coolant requirements are not a guarantee against corrosion but should be considered as a tool to avoid the most critical issues.

Danfoss MicroChannel Heat Exchangers (Jia Xing) Co., Ltd.  
No. 8, Sangdelan Road, Wuyuan Street,  
Haiyan, Zhejiang Province  
314300 P.R. China  
[www.danfoss.com](http://www.danfoss.com)

#### Danfoss A/S

Climate Solutions • [danfoss.com](http://danfoss.com) • +45 7488 2222

Any information, including, but not limited to information on selection of product, its application or use, product design, weight, dimensions, capacity or any other technical data in product manuals, catalogues descriptions, advertisements, etc. and whether made available in writing, orally, electronically, online or via download, shall be considered informative, and is only binding if and to the extent, explicit reference is made in a quotation or order confirmation. Danfoss cannot accept any responsibility for possible errors in catalogues, brochures, videos and other material. Danfoss reserves the right to alter its products without notice. This also applies to products ordered but not delivered provided that such alterations can be made without changes to form, fit or function of the product.  
All trademarks in this material are property of Danfoss A/S or Danfoss group companies. Danfoss and the Danfoss logo are trademarks of Danfoss A/S. All rights reserved.