

Danfoss

ENGINEERING
TOMORROW

Selection Guide | iC7-Marine, iC7-Hybrid

Open up for **flexible**
integration with extraordinary
power density



Intelligence

to empower your
applications

Contents



- 🔗 Liquid-cooled System Modules 4**
 - Modular architecture 6
 - Features and benefits 8
 - Key specifications..... 10

- Ratings***
 - Inverter module (INU) 13
 - AFE module 17
 - Grid Converter module..... 21
 - DC/DC Converter 25

 - Dimensions 29



iC7-Marine and iC7-Hybrid

Open a new dimension of opportunities

Available as liquid-cooled system modules, these ultra-compact drives and power converters offer you fast system integration, high performance, and long lifetime. No matter where in the world, enjoy integrated compliance and cybersecurity – onshore and on board.



Liquid-cooled System Modules

Need flexible integration with extraordinary power density?

Optimize installation footprint, speed and reduce costs more than you dreamt possible, with the revolutionary iC7 series liquid-cooled system modules with integration unit.

High power density thanks to new filter technology means you achieve a smaller footprint and reduce space requirements in your electrical room. Filters integrate beneath the module, so you don't need extra cabinet space for them.

Enjoy optimal cabinet integration, with input and output filters contained within the pre-wired integration unit. Mechanical integration is fast with unified mechanical interfaces and modular design.

Meet weight restrictions more easily with iC7 liquid-cooled system modules, which are amazingly lightweight compared to standard solutions on the market.

Power density is optimized for a universal 600 mm depth cabinet. Install multiple units in parallel to achieve power range up to 6 MW, with no need for an output filter. Service is faster with lightweight power units; and with quick coolant connectors, there is no need to drain the cooling system.

Reduce your operating costs with industry-benchmark liquid cooling. These modules offer true liquid cooling technology with very low losses to air. There's no need to spend time on connections, since cooling distribution to filters and system modules is built-in.

Robust in harsh environments

The combined vibration, temperature, humidity, and moisture/dust resistance with IP55 electronics compartment, ensures more reliable operation than most alternative drives. Run at 60 °C with no derating.

Achieve flexibility with our highly expandable filter concept. Select your choice of input and output filter options in the integration unit located beneath the module. The same mechanical concept serves all module variants: INU, AFE, GC, and DC/DC.

HIGHLIGHTS

- **Save space with world-class power density**
- **Market leading weight savings makes it ideal for light weight installations**
- **Reliable even in harsh conditions**
- **Fast mechanical integration**
- **Fast and easy service**
- **Close to silent operation**
- **World-first drive with cyber-secure design**
- **More uptime, longer service intervals and long storage life due to film capacitor technology**
- **Liquid cooling enables reuse of waste heat for energy efficiency**

Pack in more
power





Modular architecture

Setting the **standard** for modular **control**

A flexible, modular, control architecture means you can tailor the control functionality exactly to your needs. You can purchase exactly the control options you need, or replace PLC components, I/O and external safety components.

This modularity gives you not only more flexibility, but more secure integration of drives and power converters in the control system and IT architecture. You achieve faster set-up, and smarter monitoring, data gathering and analytics thanks to support for multiple communication protocols.

The purchase cost is lower since you only buy the necessary control options, saving excess unused functionality. The drive or power converter can reduce your costs further by substituting for a low-end PLC controller/system.

Program execution close to the process opens new possibilities in maritime control thanks to reduced delays. Built-in security protects your IPR and service business.

Technical information

- Integrated Ethernet port
- Dual-channel STO SIL3 integrated as standard
- Modbus TCP as standard and other fieldbus protocols optional
- Basic I/O: 6x DI, 2x DO, 2x AI +/-10V/0-20 mA, 1x AO (0-10/4-20 mA), 2x NO/NC RO, 1x NO RO, 1x Thermistor
- One optical fiber pair as communication link with power module or star coupler board
- For more options such as voltage measurement, temperature measurement, relay option, and encoder option, refer to the Functional extensions fact sheet.

Functional extensions

Control mounting plate mechanics



Control and option boards

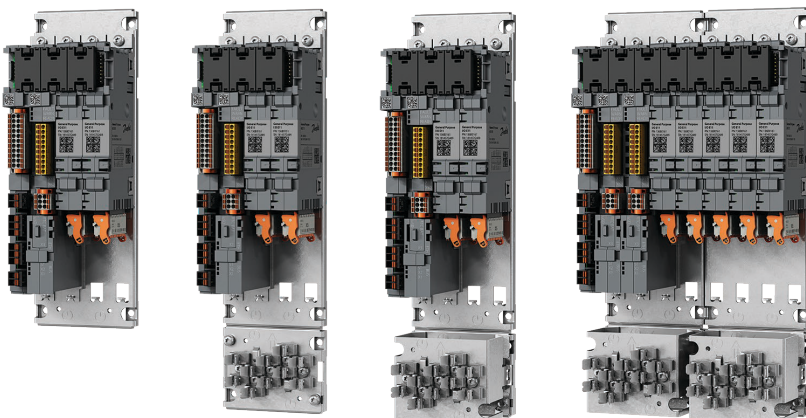
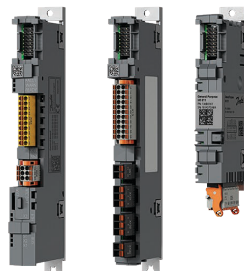

Features and benefits – all liquid-cooled system modules

Feature	Benefit
Market-leading power density	Save space and weight in marine and urban installations
World's most reliable drive Robust thanks to high quality design: vibration- and shock-resistant aluminium frame with IP55 protected electronics compartment	High uptime Peace of mind even in unpredictable conditions
Output filters and fuses integrate neatly below the power module	Reduced footprint. Reduced cost of integration and service
Performs reliably at high ambient and coolant temperatures	High uptime in harsh environments
Quick connectors, no draining of liquid, quick cabling	Fast serviceability
Cloud connectivity is cybersecure	Reduced risk of unauthorized access or cybersecurity incident
Same mechanical integration for all applications (INU, AFE, GC, DC/DC) means fewer variants are required	Reduce storage required for spares and complexity in integration Simplify serviceability
Modular and scalable. Fewer variants. No need for output filters when installing modules in parallel.	Reduce cost of integration Go to market faster Simplify serviceability
Long design life and film capacitor technology	Reduced maintenance downtime
True liquid cooling ensures low losses to air and enables reuse of waste heat for energy efficiency	Highest possible system efficiency Reduced air conditioning need
DNV, ABS, LR, BV, CCS, KR and NK ¹⁾ certifications, including type approvals for the system module and filters in the integration unit	Accelerate certification time for marine systems

¹⁾ Certification pending

Liquid-cooled module types

Control unit and control options



Star coupler board

System modules AM/IM/DM10L modules



System modules AM/IM/DM12L modules



Inverter unit IR10L with or without filters



Inverter unit IR12L with or without filters



AFE & GC AR10L with LC-filter



AFE & GC AR12L with LC-filter



DC/DC Converter DR10L With DC/DC filter



Illustrations not to scale

DC/DC Converter DR12L With DC/DC filter



System module(s) for integration unit



Integration unit: contains options "+AE_" input or output filter



Example AFE module with LC-filter



Enclosure solution example



1.8 MVA Grid Converter or AFE with LC filter in 600 mm wide enclosure

Highly compact cooling unit

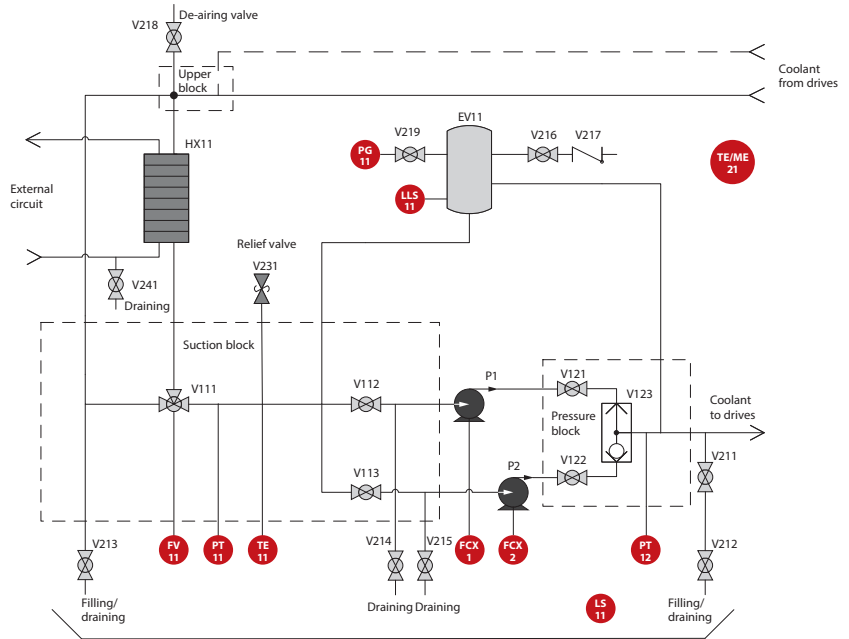

The iC7 series liquid-cooled system modules empower you to pack a lot of power into a small space, to optimize your systems – and give you new application opportunities. At the heart of this groundbreaking technology is the cooling unit.

The cooling unit is service-friendly despite its extremely compact design, making it fast and easy to work with.

The cooling unit gives you especially easy access to the pump, as well as providing pump shut-off valves.

What's included in the cooling unit

- Liquid cooling temperature control with integrated 3-way valve
- Extensive sensor package with humidity and ambient temperature measurement

Compatibility

- Compatible with diverse Ethernet-based fieldbuses

Type approvals

- DNV, ABS¹⁾, LR¹⁾, BV¹⁾ and CCS¹⁾

¹⁾ Certification pending

Technical information

System pressure

- Customer side: max 1000 kPa
- Drive side working pressure: 50-350 kPa, maximum 600 kPa

Cooling

- Ambient temperature: -15-55 °C
- Coolant temperature: -15-38 °C (lth) (nominal); 38-55 °C with limited performance

- Cooling unit supply distance: 15-25 m, optionally up to 40 m
- Drive-side temperature control with 3-way valve and actuator

Sensor measurements on the drive side

- Pressure
- Flow (pressure sensor-based)
- Temperature

- Leakage detection
- Condensation (humidity/ambient temperature sensor-based.)

Optional extras

- Enclosure IP23 (without enclosure) and IP54
- Double/redundant pump
- Coolant connectors positioned on left or right side of the cooling unit

Cooling unit					
Model code	Cooling power [kW]	Coolant flow [l/min]	Pump quantity	Dimensions IP23 enclosures W x H x D [mm]	Dimensions IP54 enclosures W x H x D [mm]
iC7-60SLQxx-0076...	76	190	1 and 2	300/500 x 1900 x 550	408/608 x 2060 x 608
iC7-60SLQxx-0152...	152	360	1 and 2	300/500 x 1900 x 550	408/608 x 2060 x 608

Key specifications

Mains connection (AFE & GC)	
Mains voltage U_{in}	<ul style="list-style-type: none"> – Voltage class 07: 3 x 525-690 V AC (-15% – +10%); 640-1100 VDC (-0% – +0%) – Voltage class B5: 3 x 380-500 V AC (-15%...+10%); 465-800 V DC (-0%...+0%)
Mains frequency	– 45-66 Hz AFE, GC, 25-70 Hz for GC with derating
Supply network	<ul style="list-style-type: none"> – TN-S, TN-C, IT and TT – Supply voltage limited to 500 V AC for corner grounded networks
Power factor	<ul style="list-style-type: none"> – $\cos\phi = 1$: (fundamental) (AFE module) – $\cos\phi = 1$ leading to 1 lagging (fundamental) (GC module)
Short circuit current	– Maximum short circuit current must be < 100 kA
Total harmonics distortion THDi	– < 5%: (AFE and GC module), < 3% with dedicated transforme
Overvoltage category	– Class III according to IEC/EN 61800-5-1
Imbalance	<ul style="list-style-type: none"> – Nominal performance with voltage imbalance $\leq 3\%$. (AFE and GC module) – Limited performance with >3% voltage imbalance
Connections to mains	– Once every 120 s

Motor/generator connection (INU)	
Output voltage	– $0-U_{in}$, 3-phase
Output frequency	– 0-599 Hz (<i>Limited performance with output filters above 70 Hz</i>)
Switching frequency	– 1.5-10 kHz (525-690 V AC) Default switching frequency 3 kHz
Motor/generator control principles	<ul style="list-style-type: none"> – U/f control – Voltage Vector Control (VVC+) – Flux Vector Control (FVC+)
Motor and generator types supported	<ul style="list-style-type: none"> – Induction/asynchronous motor – Permanent magnet motor – Salient permanent magnet motor – Synchronous reluctance assisted permanent magnet motor
Cable length	– Up to 150 m [492 feet] with symmetrical 3-phase screened motor cable

DC connection (DC/DC converter)	
DC bus voltage	<ul style="list-style-type: none"> – Voltage class 07: 640-1100 VDC (-0%..+0%) – Voltage class B5: 465-800 V DC (-0%..+0%)
DC source voltage	<ul style="list-style-type: none"> – 3%-100% of DC bus voltage – 3%-97% of DC bus voltage with full control performance
Source current ripple with iC7 DC/DC Filters	<ul style="list-style-type: none"> – DR10L < 1% RMS (typical) – DR12L < 0.5% RMS (typical)

EMC (IEC61800-3)	
Immunity	– Fulfils IEC/EN61800-3 (2018), 2nd environment
Emissions	<ul style="list-style-type: none"> – IEC/EN61800-3 (2018), category C4, default for the IP00/UL Open Type drive – IEC/EN61800-3 (2018), category C3, if the drive is installed according to the instructions of the manufacturer (<i>C3 not applicable for DC/DC Converter</i>) – CISPR 11 (EN 55011) Class A (<i>Grid Converter</i>)

Liquid cooling	
Temperature of cooling agent	<ul style="list-style-type: none"> -10 to +45°C (I_N)(nominal), up to 60 C with derating Temperature rise during circulation max 10°C Glycol to be used in cooling agent below 0°C and ice formation not permitted
System max. working pressure	<ul style="list-style-type: none"> Operating pressure 100-150 kPa (recommended) Maximum pressure 500 kPa
Pressure drop	<ul style="list-style-type: none"> 50-120 kPa at rated volumetric flow.
Allowed cooling agents	<ul style="list-style-type: none"> Demineralized water or good pure quality water according to cooling liquid quality specification with inhibitor and propylene or ethylene glycol
Corrosion inhibitor	<ul style="list-style-type: none"> Corrosion inhibitor recommended, for long lifetime
Allowed materials in the cooling system	<ul style="list-style-type: none"> Aluminum Stainless steel AISI 304/316 Plastic (PVC not allowed) Elastomers (EPDM, NBR, FDM)

Environmental conditions	
Protection rating drive modules	<ul style="list-style-type: none"> IP00/UL Open Type
Ambient operating temperature	<ul style="list-style-type: none"> -15°C (no frost) to +60°C (at I_N)
Storage/transportation temperature	<ul style="list-style-type: none"> -40°C to +70°C; glycol to be used in liquid under 0°C and ice formation not permitted
Relative humidity	<ul style="list-style-type: none"> 5 to 96% RH, no dripping water or condensation allowed
Pollution degree	<ul style="list-style-type: none"> PD3
Altitude	<ul style="list-style-type: none"> 0-3000 m above sea level: voltage class 07 without AFE supply 0-2000 m: voltage class 07 with AFE supply Above 1,000 m derating of maximum ambient operating temperature by 0.5 °C per each 100 m is required
Vibration (IEC60068-2-6)	<ul style="list-style-type: none"> Displacement amplitude 1 mm (peak) at 2-13.2 Hz Maximum acceleration amplitude 0.7 G at 13.2-100 Hz with maximum amplification of 5
Shock (IEC60068-2-27)	<ul style="list-style-type: none"> Max 15G, 11 ms (<i>in package</i>)
Environmental operating conditions (IEC 60721-3-3)	<ul style="list-style-type: none"> Climatic conditions: Class 3K22 Chemically active substances: IEC 60721-3-3 Edition 3.0/ISO 3223 Second Edition, class C4 Biological conditions: Class 3B1 Mechanically active substances: Class 3S6 Special climatic conditions (heat radiation): Class 3Z1

Run at
60°C
 with no derating

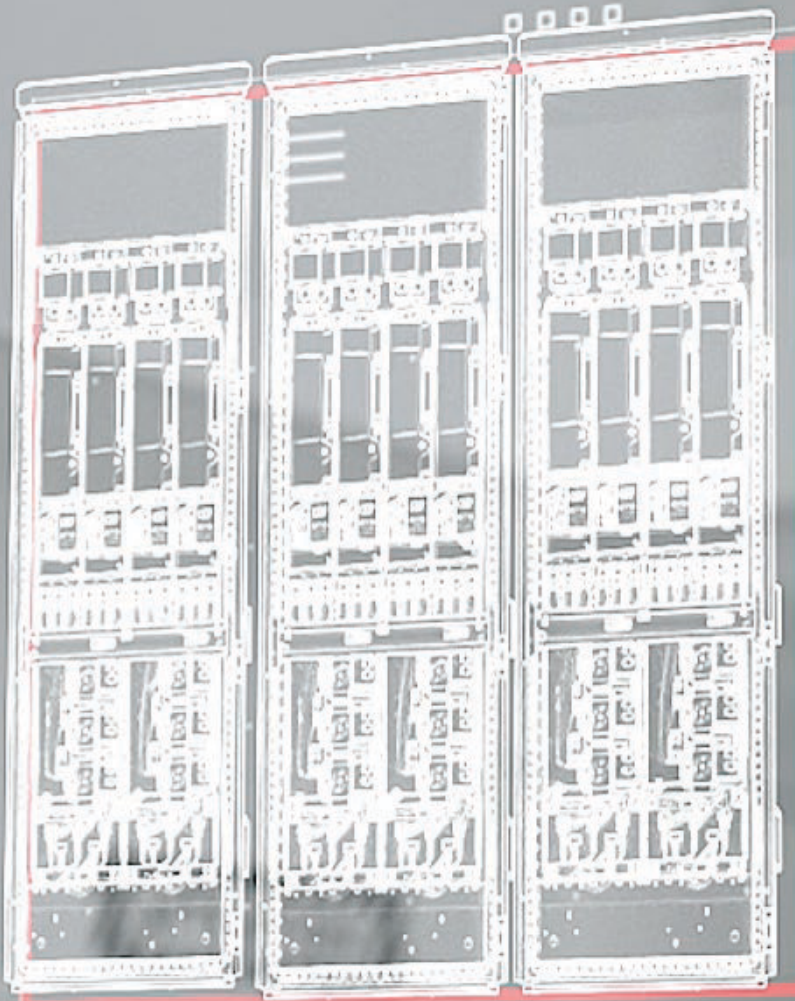

40%
LESS SPACE REQUIRED

STREAM D

INU modules

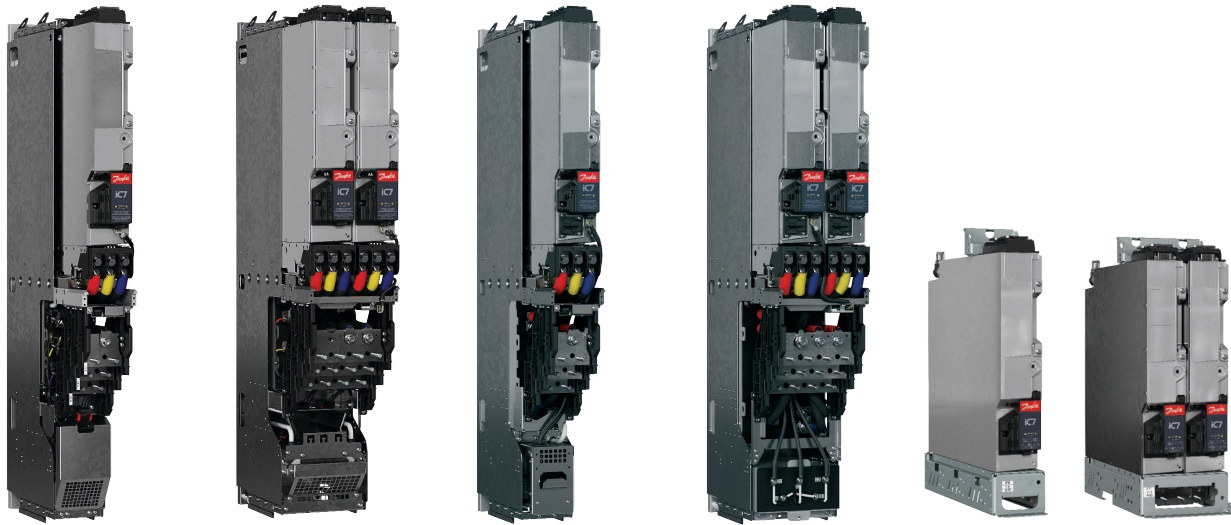

Inverter module (INU)

The inverter module is a bidirectional DC-fed power inverter for the supply and control of AC motors and generators.

The inverter (INU) module is intended for the regulation of motor speed in response to system feedback or to remote commands from external controllers. A drive system consists of the system modules, the motor, and equipment driven by the motor. The INU module is also intended for system and motor status surveillance.

Benefits of the Inverter module

- Designed for maximum machine performance and flexibility
- Versatility for drive applications requiring a wide range of drive features for different motor types for either closed loop or open loop control methods
- Optional system module with integration unit including high performance dU/dt filters and/or common-mode filters as well as sine wave filter for space saving

Ratings

- 170-6400 A IL, +10% overload 1 min/5 min
- 525-690 V AC / 640-1100 V DC (07)
- 380-500 V AC / 465-800 V DC (B5)
- Output frequency: 0-599 Hz
- dU/dt filter up to 250 Hz with derating
- Sine-wave filter up to 300 Hz with derating
- Switching frequency: 2-10 kHz. Nominal 3 kHz, Sine-wave filter 8 kHz
- Ambient temperature 60 °C at IN
- Coolant temperature 45 °C at IN with the exception of 38 °C at IN for 07 voltage class Sine-wave filter current ratings 730 A, 1400 A, 2080 A 2830 A, 3500 A and 4400 A

Highlights

- Most compact INU module on the market thanks to integration of filters
- Robust and reliable in varying ambient conditions
- Designed for enclosure integration and quick serviceability
- Multipurpose use cases for motor or generator control and shore connection (AFE) with Generator application software

Motor and generator control

- Highly dynamic performance: Highest possible machine accuracy due to superior shaft performance, also for sensorless operation
- Superior low-speed performance also in sensorless operation
- The motor always runs at maximum possible torque for the given current – ensuring highest possible motor efficiency: Maximum Torque Per Ampere (MTPA)
- Fast commissioning using Automatic Motor Adaption (AMA) at standstill maximizes energy efficiency with any motor
- More integrated sensors for better performance
- Flexible choice of control features optimized to your application, thanks to integrated application software
- Variable speed power generation with stable DC voltage reference even without filter
- Externally excited synchronous generator supported with Generator application and AFE control mode

Inverter module (INU) ratings at 500 V AC

iC7-60SLINB5, 380-500 V AC (465-800 VDC), IP00 Liquid-Cooled inverter module

Model code	AC ratings ¹⁾				Motor output power ²⁾		Frame	Frame with option +AE__	Filter options available ³⁾	
	3 x 380-500 V				500 V AC mains				+AEU1 +AEU2 +AE10	+AES1 +AEZ1 ⁴⁾
	I _N	I _L	I _H	I _{peak}	P _L	P _H				
	[A]	[A]	[A]	[A]	[kW]	[kW]				
iC7-60SLINB5-206AE00F4	211	206	155	310	132	90	IM10L	IR10L	X	
iC7-60SLINB5-245AE00F4	251	245	184	368	160	110	IM10L	IR10L	X	
iC7-60SLINB5-302AE00F4	309	302	227	454	200	132	IM10L	IR10L	X	
iC7-60SLINB5-385AE00F4	394	385	289	578	250	160	IM10L	IR10L	X	
iC7-60SLINB5-416AE00F4	425	416	312	624	270	200	IM10L	IR10L	X	
iC7-60SLINB5-525AE00F4	536	525	393	786	355	250	IM12L	IR12L	X	X
iC7-60SLINB5-590AE00F4	603	590	442	884	400	250	IM12L	IR12L	X	X
iC7-60SLINB5-650AE00F4	672	658	487	974	400	315	IM12L	IR12L	X	X
iC7-60SLINB5-730AE00F4	746	730	547	1094	500	355	IM12L	IR12L	X	X
iC7-60SLINB5-820AE00F4	838	820	615	1230	560	400	IM12L	IR12L	X	
iC7-60SLINB5-1060AE00F4	1083	1060	795	1590	630	500	2xIM12L	2xIR12L	X	X
iC7-60SLINB5-1230AE00F4	1256	1230	922	1844	800	630	2xIM12L	2xIR12L	X	X
iC7-60SLINB5-1400AE00F4	1430	1400	1050	2100	900	710	2xIM12L	2xIR12L	X	X
iC7-60SLINB5-1500AE00F4	1532	1500	1125	2250	1000	710	2xIM12L	2xIR12L	X	
iC7-60SLINB5-1640AE00F4	1675	1640	1230	2460	1100	800	2xIM12L	2xIR12L	X	
iC7-60SLINB5-1795AE00F4	1833	1795	1346	2692	1200	900	3xIM12L	3xIR12L	X	X
iC7-60SLINB5-2080AE00F4	2124	2080	1560	3120	1400	1000	3xIM12L	3xIR12L	X	X
iC7-60SLINB5-2300AE00F4	2348	2300	1725	3450	1500	1100	3xIM12L	3xIR12L	X	
iC7-60SLINB5-2500AE00F4	2552	2500	1875	3750	1700	1200	3xIM12L	3xIR12L	X	
iC7-60SLINB5-2830AE00F4	2889	2830	2122	4244	2600	1950	4xIM12L	4xIR12L	X	X
iC7-60SLINB5-3050AE00F4	3114	3050	2287	4574	2800	2000	4xIM12L	4xIR12L	X	
iC7-60SLINB5-3260AE00F4	3328	3260	2445	4890	3000	2200	4xIM12L	4xIR12L	X	

¹⁾ **Ratings are valid at 800 V nominal DC voltage**

I_N Nominal (thermal) continuous current. Dimensioning can be done according to this current if the process does not require any overloadability or the process does not include any load variation or margin for overloadability

I_L Low overload – 110% overload – 1 min every 5 min

I_H High overload – 150% overload – 1 min every 5 min

I_{peak} Peak output current. Available for 3 seconds at start, then as long as allowed by system module temperature

²⁾ All values with efficiency = 98.5%

³⁾ +AEU1 = dU/dt filter in Integration unit; +AEU2 = dU/dt + CM filter in Integration unit; +AE10 = Integration unit without filter;

+AES1 = Sine-wave filter in Integration unit

⁴⁾ +AEZ1 only available for iC7-Hybrid with Generator application

Inverter module (INU) ratings at 690 V AC

iC7-60SLIN07, 525-690 V AC (640-1100 V DC), Type Open/IP00 inverter module

Model code	AC ratings ¹⁾				Motor output power ²⁾		Frame	Frame with option +AE	Filter options available ³⁾	
	3 x 525-690 V				690 V AC mains				+AEU1 +AEU2 +AE10	+AES1 +AEZ1 ⁴⁾
	I _N	I _L	I _H	I _{peak}	P _L	P _H				
	[A]	[A]	[A]	[A]	[kW]	[kW]				
iC7-60SLIN07-170AE00F4	174	170	127	254	160	90	IM10L	IR10L	X	
iC7-60SLIN07-208AE00F4	213	208	156	312	200	132	IM10L	IR10L	X	
iC7-60SLIN07-261AE00F4	267	261	195	390	250	160	IM10L	IR10L	X	
iC7-60SLIN07-325AE00F4	332	325	243	486	315	200	IM10L	IR10L	X	
iC7-60SLIN07-365AE00F4	373	365	273	546	355	250	IM10L	IR10L	X	
iC7-60SLIN07-416AE00F4	425	416	312	624	400	250	IM10L	IR10L	X	
iC7-60SLIN07-465AE00F4	475	465	348	696	450	315	IM12L	IR12L	X	X
iC7-60SLIN07-525AE00F4	536	525	393	786	500	355	IM12L	IR12L	X	X
iC7-60SLIN07-590AE00F4	603	590	442	884	560	400	IM12L	IR12L	X	X
iC7-60SLIN07-650AE00F4	664	650	487	974	630	450	IM12L	IR12L	X	X
iC7-60SLIN07-730AE00F4	746	730	547	1094	710	500	IM12L	IR12L	X	X
iC7-60SLIN07-820AE00F4	838	820	615	1230	800	560	IM12L	IR12L	X	
iC7-60SLIN07-945AE00F4	965	945	708	1416	900	630	2xIM12L	2xIR12L	X	X
iC7-60SLIN07-1060E00F4	1083	1060	795	1590	1000	710	2xIM12L	2xIR12L	X	X
iC7-60SLIN07-1230E00F4	1256	1230	922	1844	1100	800	2xIM12L	2xIR12L	X	X
iC7-60SLIN07-1400E00F4	1430	1400	1050	2100	1300	900	2xIM12L	2xIR12L	X	X
iC7-60SLIN07-1500E00F4	1532	1500	1125	2250	1400	1000	2xIM12L	2xIR12L	X	
iC7-60SLIN07-1640E00F4	1675	1640	1230	2460	1500	1100	2xIM12L	2xIR12L	X	
iC7-60SLIN07-1795E00F4	1833	1795	1346	2692	1700	1250	3xIM12L	3xIR12L	X	X
iC7-60SLIN07-2080E00F4	2124	2080	1560	3120	1900	1400	3xIM12L	3xIR12L	X	X
iC7-60SLIN07-2300E00F4	2348	2300	1725	3450	2100	1600	3xIM12L	3xIR12L	X	
iC7-60SLIN07-2500E00F4	2552	2500	1875	3750	2300	1750	3xIM12L	3xIR12L	X	
iC7-60SLIN07-2830E00F4	2889	2830	2122	4244	2600	1950	4xIM12L	4xIR12L	X	X
iC7-60SLIN07-3050E00F4	3114	3050	2287	4574	2800	2000	4xIM12L	4xIR12L	X	
iC7-60SLIN07-3260E00F4	3328	3260	2445	4890	3000	2200	4xIM12L	4xIR12L	X	
iC7-60SLIN07-3500E00F4	3573	3500	2625	5250	3300	2400	5xIM12L	5xIR12L	X	X
iC7-60SLIN07-4035E00F4	4119	4035	3026	6052	3800	2800	5xIM12L	5xIR12L	X	
iC7-60SLIN07-4400E00F4	4492	4400	3300	6600	4100	3100	6xIM12L	6xIR12L	X	X
iC7-60SLIN07-4850E00F4	4951	4850	3637	7274	4500	3500	6xIM12L	6xIR12L	X	
iC7-60SLIN07-5300E00F4	5411	5300	3975	7950	5000	3700	7xIM12L	7xIR12L	X	
iC7-60SLIN07-5600E00F4	5717	5600	4200	8400	5300	4000	7xIM12L	7xIR12L	X	
iC7-60SLIN07-6100E00F4	6227	6100	4575	9150	5700	4300	8xIM12L	8xIR12L	X	
iC7-60SLIN07-6400E00F4	6534	6400	4800	9600	6000	4600	8xIM12L	8xIR12L	X	

¹⁾ Ratings are valid at 1025 V nominal DC voltage

I_N Nominal (thermal) continuous current. Dimensioning can be done according to this current if the process does not require any overloadability

or the process does not include any load variation or margin for overloadability

I_L Low overload – 110% overload – 1 min every 5 min

I_H High overload – 150% overload – 1 min every 5 min

I_{peak} Peak output current. Available for 3 seconds at start, then as long as allowed by system module temperature

²⁾ All values with efficiency = 98.5%

³⁾ +AEU1 = dU/dt filter in Integration unit; +AEU2 = dU/dt + CM filter in Integration unit; +AE10 = Integration unit without filter;

+AES1 = Sine-wave filter in Integration unit

⁴⁾ +AEZ1 only available for iC7-Hybrid with Generator application



AFE modules

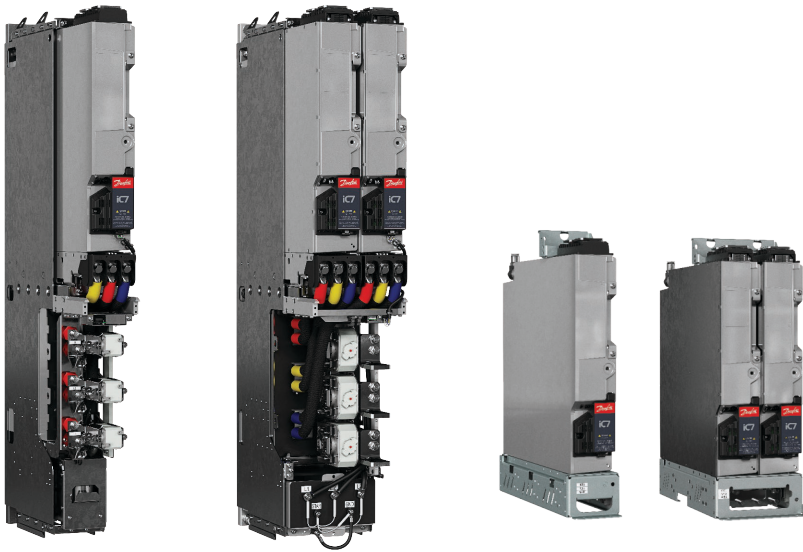

AFE module

The AFE unit is a bi-directional low harmonic supply unit for motor drive applications. Active front end is typically used as a supply to a common DC bus drive line-ups or single drives when low harmonics or regeneration of power back to the grid is needed/valued.

The main functionality of the AFE is to maintain stable DC-link voltage reference. The AFE transfers power between the grid and the DC bus both ways depending on the load of the DC bus.

Benefits of the AFE

- Regenerative energy is fed back to the grid, improving the payback time of the investment. Regeneration at full power is available at any time.
- The AFE can boost the DC-link voltage within the voltage window of the converter hardware. Its advantage is that the DC-voltage available for motor inverters is not limited even under non-ideal grid conditions.

- Power quality is excellent since the grid current is sinusoidal with very low harmonics (<5% THDi) and power factor is unity ($\cos \varphi = 1$) This means that there is no need to oversize incoming supply transformers, as for traditional diode rectifiers, which reduces investment costs and space.

Ratings

- 236-5750 A I_L , +10% overload 1 min/5 min
- 525-690 V AC / 640-1100 V DC (07)
- 380-500 V AC / 465-800 V DC (B5)
- 45-66 Hz Grid frequency
- THDi <5%
- Fundamental power factor $\cos \varphi = 1$, adjustable reactive current set point
- Ambient temperature 60 °C at I_N
- Coolant temperature 45 °C at I_N , with the exception of 38 °C at I_N for current ratings 380 A, 760 A, 1500 A, 2250 A, 2940 A, 3600 A, 4320 A, 5040 A, 5750 A.

Highlights

- Most compact AFE on the market thanks to integration of LC-filter and fuses
- Meets the most stringent harmonics requirements thanks to high DC and AC power quality

- Robust and reliable in varying ambient conditions
- Designed for enclosure integration and quick serviceability
- Lowest weight on the market thanks to new filter technology

DC-bus and grid control

- Fast primary control ensures stable DC voltage even under non-ideal grid conditions for accurate motor control.
- AFE is able to boost DC voltage to guarantee full motor voltage even when the supply voltage is below nominal.
- Low harmonic operation meets even the strictest power quality requirements for drive systems.
- Reactive reference can be used to compensate other low power factor equipment in the network.
- Unrivalled paralleling options with no need for drive-to-drive communication
- Power can be shared between parallel units automatically with DC-link voltage droop control.

Active front-end (AFE) ratings at 690 V AC

iC7-60SL3A07, 525-690 V AC (640-1100 V DC), Type Open / IP00 active front-end

Product code	AC current			DC power ²⁾		Frame size	Frame with option +AEZ1 or +AEZ3 ³⁾	L-filter size (part of LCL-filter +AEZ3 ³⁾)
	Current ratings ¹⁾			690 V AC mains				
	I _N	I _L	I _H	P _L	P _H			
	[A]	[A]	[A]	[kW]	[kW]			
iC7-60SL3A07-236AE00F4	241	236	177	277	208	AM10L	AR10L	OF7Z5-M-LC-07-400A-A1-E00-F4
iC7-60SL3A07-300AE00F4	307	300	225	352	264	AM10L	AR10L	OF7Z5-M-LC-07-400A-A1-E00-F4
iC7-60SL3A07-334AE00F4	341	334	250	392	293	AM10L	AR10L	OF7Z5-M-LC-07-400A-A1-E00-F4
iC7-60SL3A07-380AE00F4	388	380	285	446	334	AM10L	AR10L	OF7Z5-M-LC-07-400A-A1-E00-F4
iC7-60SL3A07-425AE00F4	434	425	318	498	373	AM12L	AR12L	OF7Z5-M-LC-07-1000-A1-E00-F4
iC7-60SL3A07-475AE00F4	485	475	356	557	417	AM12L	AR12L	OF7Z5-M-LC-07-1000-A1-E00-F4
iC7-60SL3A07-530AE00F4	542	530	397	621	465	AM12L	AR12L	OF7Z5-M-LC-07-1000-A1-E00-F4
iC7-60SL3A07-595AE00F4	608	595	446	697	523	AM12L	AR12L	OF7Z5-M-LC-07-1000-A1-E00-F4
iC7-60SL3A07-670AE00F4	684	670	502	785	588	AM12L	AR12L	OF7Z5-M-LC-07-1000-A1-E00-F4
iC7-60SL3A07-760AE00F4	776	760	570	891	668	AM12L	AR12L	OF7Z5-M-LC-07-1000-A1-E00-F4
iC7-60SL3A07-850AE00F4	868	850	637	996	747	2xAM12L	2xAR12L	OF7Z5-M-LC-07-1640-A1-E00-F4
iC7-60SL3A07-945AE00F4	965	945	708	1107	830	2xAM12L	2xAR12L	OF7Z5-M-LC-07-1640-A1-E00-F4
iC7-60SL3A07-1040E00F4	1062	1040	780	1219	914	2xAM12L	2xAR12L	OF7Z5-M-LC-07-1640-A1-E00-F4
iC7-60SL3A07-1230E00F4	1256	1230	922	1441	1080	2xAM12L	2xAR12L	OF7Z5-M-LC-07-1640-A1-E00-F4
iC7-60SL3A07-1325E00F4	1353	1325	993	1552	1164	2xAM12L	2xAR12L	OF7Z5-M-LC-07-1640-A1-E00-F4
iC7-60SL3A07-1500E00F4	1532	1500	1125	1757	1318	2xAM12L	2xAR12L	OF7Z5-M-LC-07-1640-A1-E00-F4
iC7-60SL3A07-1700E00F4	1736	1700	1275	1992	1494	3xAM12L	3xAR12L	2xOF7Z5-M-LC-07-1640-A1-E00-F4
iC7-60SL3A07-1800E00F4	1838	1800	1350	2109	1582	3xAM12L	3xAR12L	2xOF7Z5-M-LC-07-1640-A1-E00-F4
iC7-60SL3A07-2000E00F4	2042	2000	1500	2343	1757	3xAM12L	3xAR12L	2xOF7Z5-M-LC-07-1640-A1-E00-F4
iC7-60SL3A07-2250E00F4	2297	2250	1687	2636	1976	3xAM12L	3xAR12L	2xOF7Z5-M-LC-07-1640-A1-E00-F4
iC7-60SL3A07-2500E00F4	2552	2500	1875	2929	2197	4xAM12L	4xAR12L	2xOF7Z5-M-LC-07-1640-A1-E00-F4
iC7-60SL3A07-2650E00F4	2706	2650	1987	3104	2328	4xAM12L	4xAR12L	2xOF7Z5-M-LC-07-1640-A1-E00-F4
iC7-60SL3A07-2940E00F4	3002	2940	2205	3444	2583	4xAM12L	4xAR12L	2xOF7Z5-M-LC-07-1640-A1-E00-F4
iC7-60SL3A07-3120E00F4	3185	3120	2340	3655	2741	5xAM12L	5xAR12L	3xOF7Z5-M-LC-07-1640-A1-E00-F4
iC7-60SL3A07-3600E00F4	3675	3600	2700	4217	3163	5xAM12L	5xAR12L	3xOF7Z5-M-LC-07-1640-A1-E00-F4
iC7-60SL3A07-3900E00F4	3982	3900	2925	4568	3426	6xAM12L	6xAR12L	3xOF7Z5-M-LC-07-1640-A1-E00-F4
iC7-60SL3A07-4320E00F4	4410	4320	3240	5060	3795	6xAM12L	6xAR12L	3xOF7Z5-M-LC-07-1640-A1-E00-F4
iC7-60SL3A07-4750E00F4	4849	4750	3562	5564	4172	7xAM12L	7xAR12L	4xOF7Z5-M-LC-07-1640-A1-E00-F4
iC7-60SL3A07-5040E00F4	5145	5040	3780	5903	4428	7xAM12L	7xAR12L	4xOF7Z5-M-LC-07-1640-A1-E00-F4
iC7-60SL3A07-5400E00F4	5513	5400	4050	6325	4744	8xAM12L	8xAR12L	4xOF7Z5-M-LC-07-1640-A1-E00-F4
iC7-60SL3A07-5750E00F4	5870	5750	4312	6735	5051	8xAM12L	8xAR12L	4xOF7Z5-M-LC-07-1640-A1-E00-F4

¹⁾ Ratings are valid at 1025V nominal DC voltage

I_N Nominal (thermal) continuous current. Dimensioning can be done according to this current if the process does not require any overloadability

I_L Low overloadability current (1/5min) Allows +10% load variation for 1 minute every 5 minutes.

I_H High overloadability current (1/5min) Allows +50% load variation for 1 minute every 5 minutes.

²⁾ All values with cosφ = 1.00, efficiency = 98.0% and rated voltage 1025 VDC

³⁾ Includes LC-filter with the option +AEZ1 and LCL-filter with the option +AEZ3 net side L-filter separate module

Active front-end (AFE) ratings at 500 V AC

iC7-60SL3AB5, 380-500 V AC (465-800 V DC), Type Open/IP00 active front end¹⁾

Product code	AC current			DC power ³⁾		Frame size	Frame with option +AEZ1 or +AEZ3 ⁴⁾	L-filter size (part of LCL-filter +AEZ3 ⁴⁾)
	Current ratings ²⁾			500 V AC mains				
	I _N [A]	I _L [A]	I _H [A]	P _L [kW]	P _H [kW]			
iC7-60SL3AB5-261AE00F4	267	261	196	222	167	AM10L	AR10L	OF7Z5-M-LC-07-400A-A1-E00-F4
iC7-60SL3AB5-325AE00F4	332	325	244	276	208	AM10L	AR10L	OF7Z5-M-LC-07-400A-A1-E00-F4
iC7-60SL3AB5-380AE00F4	388	380	285	323	242	AM10L	AR10L	OF7Z5-M-LC-07-400A-A1-E00-F4
iC7-60SL3AB5-425AE00F4	434	425	318	361	270	AM12L	AR12L	OF7Z5-M-LC-07-1000-A1-E00-F4
iC7-60SL3AB5-475AE00F4	485	475	356	404	303	AM12L	AR12L	OF7Z5-M-LC-07-1000-A1-E00-F4
iC7-60SL3AB5-530AE00F4	542	530	397	450	337	AM12L	AR12L	OF7Z5-M-LC-07-1000-A1-E00-F4
iC7-60SL3AB5-595AE00F4	608	595	446	505	379	AM12L	AR12L	OF7Z5-M-LC-07-1000-A1-E00-F4
iC7-60SL3AB5-670AE00F4	684	670	502	569	427	AM12L	AR12L	OF7Z5-M-LC-07-1000-A1-E00-F4
iC7-60SL3AB5-760AE00F4	776	760	570	646	484	AM12L	AR12L	OF7Z5-M-LC-07-1000-A1-E00-F4
iC7-60SL3AB5-850AE00F4	868	850	637	722	541	2xAM12L	2xAR12L	OF7Z5-M-LC-07-1640-A1-E00-F4
iC7-60SL3AB5-945AE00F4	965	945	708	803	601	2xAM12L	2xAR12L	OF7Z5-M-LC-07-1640-A1-E00-F4
iC7-60SL3AB5-1040E00F4	1062	1040	780	883	662	2xAM12L	2xAR12L	OF7Z5-M-LC-07-1640-A1-E00-F4
iC7-60SL3AB5-1230E00F4	1256	1230	922	1044	783	2xAM12L	2xAR12L	OF7Z5-M-LC-07-1640-A1-E00-F4
iC7-60SL3AB5-1325E00F4	1353	1325	993	1125	843	2xAM12L	2xAR12L	OF7Z5-M-LC-07-1640-A1-E00-F4
iC7-60SL3AB5-1500E00F4	1532	1500	1125	1274	955	2xAM12L	2xAR12L	OF7Z5-M-LC-07-1640-A1-E00-F4
iC7-60SL3AB5-1700E00F4	1736	1700	1275	1443	1083	3xAM12L	3xAR12L	2xOF7Z5-M-LC-07-1640-A1-E00-F4
iC7-60SL3AB5-1800E00F4	1838	1800	1350	1528	1146	3xAM12L	3xAR12L	2xOF7Z5-M-LC-07-1640-A1-E00-F4
iC7-60SL3AB5-2000E00F4	2042	2000	1500	1698	1274	3xAM12L	3xAR12L	2xOF7Z5-M-LC-07-1640-A1-E00-F4
iC7-60SL3AB5-2250E00F4	2297	2250	1687	1910	1432	3xAM12L	3xAR12L	2xOF7Z5-M-LC-07-1640-A1-E00-F4
iC7-60SL3AB5-2500E00F4	2552	2500	1875	2122	1592	4xAM12L	4xAR12L	2xOF7Z5-M-LC-07-1640-A1-E00-F4
iC7-60SL3AB5-2650E00F4	2706	2650	1987	2250	1687	4xAM12L	4xAR12L	2xOF7Z5-M-LC-07-1640-A1-E00-F4
iC7-60SL3AB5-2940E00F4	3002	2940	2205	2496	1872	4xAM12L	4xAR12L	2xOF7Z5-M-LC-07-1640-A1-E00-F4

¹⁾ Main voltage 380-500 V AC (465-800 V DC) (Improved hardware transient withstand)

²⁾ **Ratings are valid at 800V DC voltage**

I_N Nominal (thermal) continuous current. Dimensioning can be done according to this current if the process does not require any overloadability

I_L Low overloadability current (1/5min) Allows +10% load variation for 1 minute every 5 minutes.

I_H High overloadability current (1/5min) Allows +50% load variation for 1 minute every 5 minutes.

³⁾ All values with cosφ = 1.00, efficiency = 98.0% and rated voltage 742 VDC

⁴⁾ Includes LC-filter with the option +AEZ1 and LCL-filter with the option +AEZ3 net side L-filter separate module

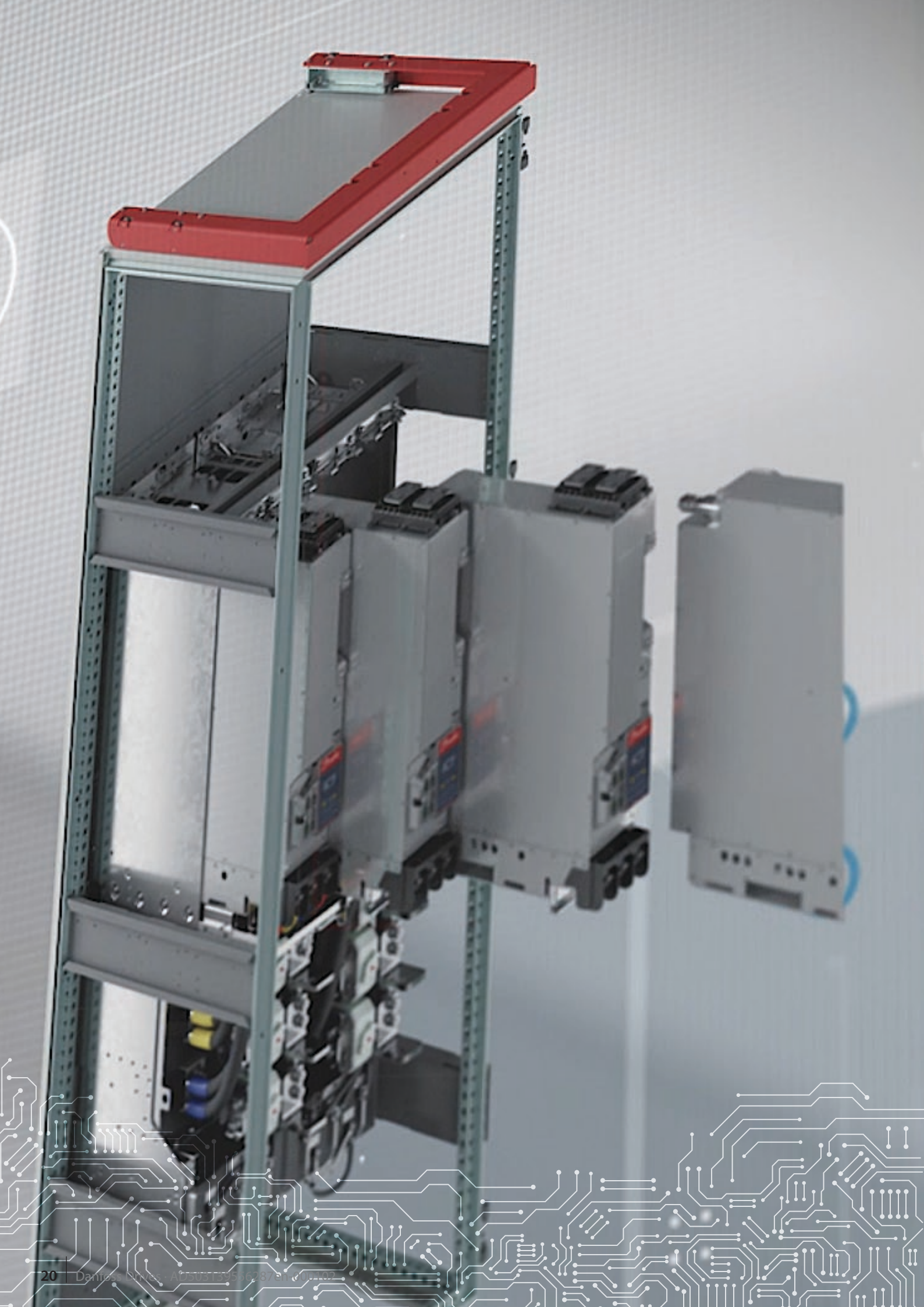

Grid Converter module

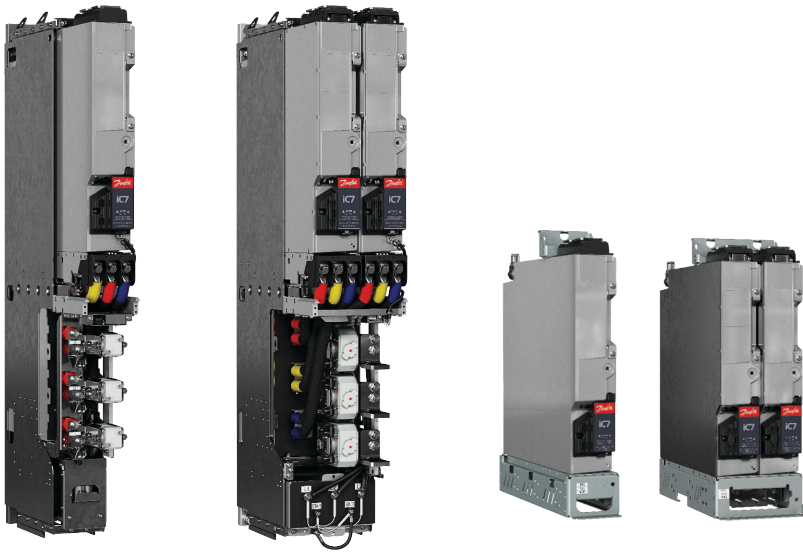

Grid Converter for advanced AC/DC power conversion

- Grid converter is a bi-directional AC/DC power converter for grid forming, advanced grid control and DC power supply applications
- Ideal for smart grid applications such as energy storage and DC power supply for hydrogen electrolysis.
- Stand-out solution for marine & offshore energy management applications such as energy storage, micro grid forming, shaft generators and shore power.

Ratings

- 236-5750 A I_L , +10% overload 1 min/5 min
- 525-690 V AC / 640-1100 V DC (07)
- 380-500 V AC / 465-800 V DC (B5)
- 45-66 Hz Grid frequency (25-70 Hz with derating)
- THDi < 5% (< 3% with dedicated transformer)
- Adjustable power factor
- Ambient temperature 60 °C at I_N

- Coolant temperature 45 °C at I_N , with the exception of 38 °C at I_N for current ratings 380 A, 760 A, 1500 A, 2250 A, 2940 A, 3600 A, 4320 A, 5040 A, 5750 A.

Highlights

- Most compact AC/DC power conversion on the market thanks to integration of filters and fuses
- High short-circuit current injection capability reduces oversizing
- Meets the stringest harmonics requirements thanks to high DC and AC power quality
- Robust and reliable in varying ambient conditions
- Designed for fast enclosure integration and quick serviceability
- Lowest weight on the market thanks to new filter technology
- Same mechanical footprint and integration as INU, AFE and DC/DC modules

State-of-the-art grid control

- Fast primary control ensures power system stability and streamlined power management
- Synchronize to external grid and compensate voltage drop thanks to dual-channel voltage measurement option
- Blackout prevention and black start
- Unrivalled paralleling options for high-power installations
- Flexible grid forming and grid following control modes to optimize system-level cost
 - DC-bus voltage
 - DC current / power
 - Active and reactive power
 - AC voltage & frequency
 - Island (grid forming)
 - Droop control
 - Droop with base load
 - Limit controllers
 - Smooth transition between grid-following and grid-forming control modes

Grid converter (GC) ratings at 690 V AC

iC7-60SLGC07, 525-690 V AC (640-1100 V DC), IP00/UL Open Type Grid Converter module

Product code	Current ratings ¹⁾					Power ratings ²⁾		Frame size	Frame with option +AE
	3 x 525-690 V					690 V AC mains			
	I _N	I _L	I _H	I _S	I _{S2}	P _L	S _L		
	[A]	[A]	[A]	[A]	[A]	[kW]	[kVA]		
iC7-60SLGC07-236AE00F4	241	236	177	354	330	277	283	AM10L	AR10L
iC7-60SLGC07-300AE00F4	307	300	225	450	420	352	359	AM10L	AR10L
iC7-60SLGC07-334AE00F4	341	334	250	501	468	392	400	AM10L	AR10L
iC7-60SLGC07-380AE00F4	388	380	285	570	532	446	455	AM10L	AR10L
iC7-60SLGC07-425AE00F4	434	425	318	638	595	498	508	AM12L	AR12L
iC7-60SLGC07-475AE00F4	485	475	356	712,5	665	557	568	AM12L	AR12L
iC7-60SLGC07-530AE00F4	542	530	397	795	742	621	634	AM12L	AR12L
iC7-60SLGC07-595AE00F4	608	595	446	892,5	833	697	712	AM12L	AR12L
iC7-60SLGC07-670AE00F4	684	670	502	1005	938	785	801	AM12L	AR12L
iC7-60SLGC07-760AE00F4	776	760	570	1140	1064	891	909	AM12L	AR12L
iC7-60SLGC07-850AE00F4	868	850	637	1275	1190	996	1016	2xAM12L	2xAR12L
iC7-60SLGC07-945AE00F4	965	945	708	1417,5	1323	1107	1130	2xAM12L	2xAR12L
iC7-60SLGC07-1040E00F4	1062	1040	780	1560	1456	1219	1243	2xAM12L	2xAR12L
iC7-60SLGC07-1230E00F4	1256	1230	922	1845	1722	1441	1470	2xAM12L	2xAR12L
iC7-60SLGC07-1325E00F4	1353	1325	993	1988	1855	1552	1584	2xAM12L	2xAR12L
iC7-60SLGC07-1500E00F4	1532	1500	1125	2250	2100	1757	1793	2xAM12L	2xAR12L
iC7-60SLGC07-1700E00F4	1736	1700	1275	2550	2380	1992	2032	3xAM12L	3xAR12L
iC7-60SLGC07-1800E00F4	1838	1800	1350	2700	2520	2109	2152	3xAM12L	3xAR12L
iC7-60SLGC07-2000E00F4	2042	2000	1500	3000	2800	2343	2391	3xAM12L	3xAR12L
iC7-60SLGC07-2250E00F4	2297	2250	1687	3375	3150	2636	2690	3xAM12L	3xAR12L
iC7-60SLGC07-2500E00F4	2552	2500	1875	3750	3500	2929	2988	4xAM12L	4xAR12L
iC7-60SLGC07-2650E00F4	2706	2650	1987	3975	3710	3104	3168	4xAM12L	4xAR12L
iC7-60SLGC07-2940E00F4	3002	2940	2205	4410	4116	3444	3514	4xAM12L	4xAR12L
iC7-60SLGC07-3120E00F4	3185	3120	2340	4680	4368	3655	3729	5xAM12L	5xAR12L
iC7-60SLGC07-3600E00F4	3675	3600	2700	5400	5040	4217	4303	5xAM12L	5xAR12L
iC7-60SLGC07-3900E00F4	3982	3900	2925	5850	5460	4568	4661	6xAM12L	6xAR12L
iC7-60SLGC07-4320E00F4	4410	4320	3240	6480	6048	5060	5163	6xAM12L	6xAR12L
iC7-60SLGC07-4750E00F4	4849	4750	3562	7125	6650	5564	5677	7xAM12L	7xAR12L
iC7-60SLGC07-5040E00F4	5145	5040	3780	7560	7056	5903	6024	7xAM12L	7xAR12L
iC7-60SLGC07-5400E00F4	5513	5400	4050	8100	7560	6325	6454	8xAM12L	8xAR12L
iC7-60SLGC07-5750E00F4	5870	5750	4312	8625	8050	6735	6872	8xAM12L	8xAR12L

¹⁾ Ratings are valid at 1025 V DC nominal voltage

I_N Nominal (thermal) continuous current. Dimensioning can be done according to this current if the process does not require any overloadability

I_L Low overload – 110% overload – 1 min every 5 min.

I_H High overload – 150% overload – 1 min every 5 min.

I_S Short-term current injection available for 1s

I_{S2} Short-term current injection available for 3.0s

²⁾ DC power is calculated with $\cos\phi = 1$, efficiency = 98% and at nominal 1025 V DC voltage

Grid converter (GC) ratings at 500 V AC

iC7-60SLGCB5, 380-500 V AC (465-800 V DC), IP00/UL Open Type Grid converter unit¹⁾

Product code	Current ratings ²⁾					Power ratings ³⁾		Frame size	Frame with option +AE_ ⁴⁾
	3 x 380-500 V					500 V AC mains			
	I_N	I_L	I_H	$I_S^{1)}$	$I_{S2}^{1)}$	P_L	S_L		
	[A]	[A]	[A]	[A]	[A]	[kW]	[kVA]		
iC7-60SLGCB5-261AE00F4	267	261	196	392	365	222	227	AM10L	AR10L
iC7-60SLGCB5-325AE00F4	332	325	244	488	455	276	282	AM10L	AR10L
iC7-60SLGCB5-380AE00F4	388	380	285	570	532	323	330	AM10L	AR10L
iC7-60SLGCB5-425AE00F4	434	425	318	638	595	361	369	AM12L	AR12L
iC7-60SLGCB5-475AE00F4	485	475	356	713	665	404	412	AM12L	AR12L
iC7-60SLGCB5-530AE00F4	542	530	397	795	742	450	459	AM12L	AR12L
iC7-60SLGCB5-595AE00F4	608	595	446	893	833	505	516	AM12L	AR12L
iC7-60SLGCB5-670AE00F4	684	670	502	1005	938	569	581	AM12L	AR12L
iC7-60SLGCB5-760AE00F4	776	760	570	1140	1064	646	659	AM12L	AR12L
iC7-60SLGCB5-850AE00F4	868	850	637	1275	1190	722	737	2xAM12L	2xAR12L
iC7-60SLGCB5-945AE00F4	965	945	708	1418	1323	803	819	2xAM12L	2xAR12L
iC7-60SLGCB5-1040E00F4	1062	1040	780	1560	1456	883	901	2xAM12L	2xAR12L
iC7-60SLGCB5-1230E00F4	1256	1230	922	1845	1722	1044	1066	2xAM12L	2xAR12L
iC7-60SLGCB5-1325E00F4	1353	1325	993	1988	1855	1125	1148	2xAM12L	2xAR12L
iC7-60SLGCB5-1500E00F4	1532	1500	1125	2250	2100	1274	1300	2xAM12L	2xAR12L
iC7-60SLGCB5-1700E00F4	1736	1700	1275	2550	2380	1443	1473	3xAM12L	3xAR12L
iC7-60SLGCB5-1800E00F4	1838	1800	1350	2700	2520	1528	1559	3xAM12L	3xAR12L
iC7-60SLGCB5-2000E00F4	2042	2000	1500	3000	2800	1698	1733	3xAM12L	3xAR12L
iC7-60SLGCB5-2250E00F4	2297	2250	1687	3375	3150	1910	1949	3xAM12L	3xAR12L
iC7-60SLGCB5-2500E00F4	2552	2500	1875	3750	3500	2122	2166	4xAM12L	4xAR12L
iC7-60SLGCB5-2650E00F4	2706	2650	1987	3975	3710	2250	2295	4xAM12L	4xAR12L
iC7-60SLGCB5-2940E00F4	3002	2940	2205	4410	4116	2496	2547	4xAM12L	4xAR12L

¹⁾ Main voltage 380...500 V AC (465...800 V DC) (Improved hardware transient withstand)

²⁾ Ratings are valid at 800 V DC voltage

I_N Nominal (thermal) continuous current. Dimensioning can be done according to this current if the process does not require any overloadability

I_L Low overloadability current (1/5min) Allows +10% load variation for 1 minute every 5 minutes.

I_H High overloadability current (1/5min) Allows +50% load variation for 1 minute every 5 minutes.

³⁾ DC power is calculated with $\cos \varphi = 1$, efficiency = 98% and 742 V DC voltage

⁴⁾ Includes LC-filter with the option +AEZ1 and LCL-filter with the option +AEZ3 (net side L-filter separate module)



DC/DC Converter

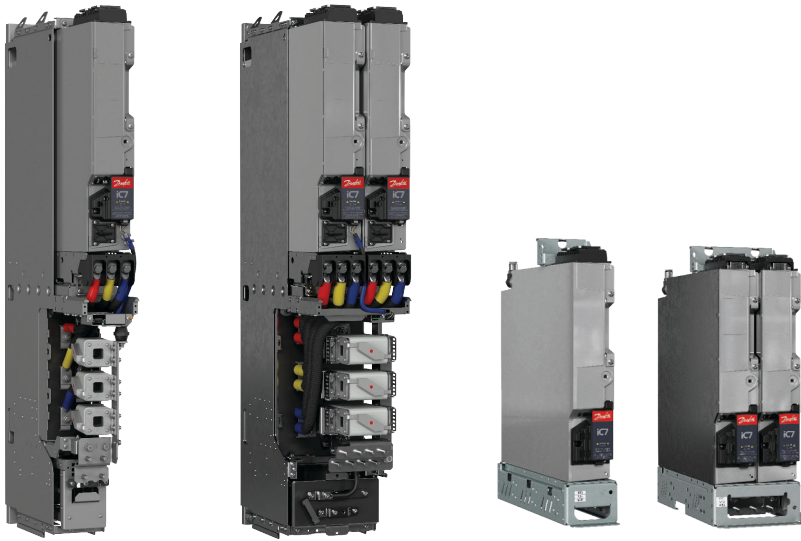

Tap in to the benefits of electrification with the DC/DC Converter

- DC/DC Converter is a bi-directional power converter enabling interconnection of two (DC) systems having different voltage levels
- Energy storage with wide voltage range can be connected to a stable DC bus
- Ideal for high-power battery or fuel cell applications
- Enables peak shaving and zero emission operation while providing additional redundancy.

Ratings

- 300-3600 A I_L , +10% overload 1 min/5 min
- 640-1100 V DC bus (07)
- 465-800 V DC bus (B5)
- DC Source voltage range 3-100% of DC bus voltage. Full control performance 3-97% of DC bus voltage

- DC source current ripple (typical):
 - DR10L < 1% RMS (typical)
 - DR12L < 0.5% RMS (typical)
- Ambient temperature 60 °C at I_N
- Coolant temperature 45 °C at I_N , with the exception of 38 °C at I_N for current ratings 1200 A, 2400 A, 3600 A

Highlights

- Most compact DC/DC Converter on the market thanks to integration of filters and fuses
- Lowest weight on the market thanks to new filter technology
- Same mechanical footprint and integration as INU, AFE and GC.
- Meets strict DC power quality requirements
- Robust and reliable in varying ambient conditions
- Designed for enclosure integration and quick serviceability

DC/DC Converter control

- Fast primary control ensures power system stability and streamlined power management
- Flexible control modes to optimize system-level cost and time to market
 - DC-bus voltage reference
 - Source voltage reference
 - Source power and current references
 - Current and voltage limit controllers
 - Smooth transition between control modes during run state
- Able to maintain stable DC bus voltage even when other power generation goes offline – added redundancy on top of the benefits of hybridization and electrification
- Black start capability

DC/DC Converter (DC) ratings at 1025 V DC

iC7-60SLDC07, 640-1100 V DC bus, IP00/UL Open Type DC/DC Converter

Model code	DC current			DC power	Frame	Frame with option +AE_
	I_N	I_L	I_H	1000..250 $V_{DC \text{ source}}$		
				$P_{L\text{-typ}}$		
[A]	[A]	[A]	[kW]			
iC7-60SLDC07-300AE00F4	307	300	225	300..75	DM10L	DR10L
iC7-60SLDC07-360AE00F4	368	360	270	360..90	DM10L	DR10L
iC7-60SLDC07-420AE00F4	429	420	315	420..105	DM10L	DR10L
iC7-60SLDC07-480AE00F4	490	480	360	480..120	DM10L	DR10L
iC7-60SLDC07-570AE00F4	582	570	428	570..142	DM10L	DR10L
iC7-60SLDC07-720AE00F4	735	720	540	720..180	DM12L	DR12L
iC7-60SLDC07-840AE00F4	858	840	630	840..210	DM12L	DR12L
iC7-60SLDC07-960AE00F4	980	960	720	960..240	DM12L	DR12L
iC7-60SLDC07-1080E00F4	1103	1080	810	1080..270	DM12L	DR12L
iC7-60SLDC07-1200E00F4	1225	1200	900	1200..300	DM12L	DR12L
iC7-60SLDC07-1440E00F4	1470	1440	1080	1440..360	2xDM12L	2xDR12L
iC7-60SLDC07-1680E00F4	1715	1680	1260	1680..420	2xDM12L	2xDR12L
iC7-60SLDC07-1920E00F4	1960	1920	1440	1920..480	2xDM12L	2xDR12L
iC7-60SLDC07-2160E00F4	2205	2160	1620	2160..540	2xDM12L	2xDR12L
iC7-60SLDC07-2400E00F4	2450	2400	1800	2400..600	2xDM12L	2xDR12L
iC7-60SLDC07-2880E00F4	2940	2880	2160	2880..720	3xDM12L	3xDR12L
iC7-60SLDC07-3240E00F4	3308	3240	2430	3240..810	3xDM12L	3xDR12L
iC7-60SLDC07-3600E00F4	3675	3600	2700	3600..900	3xDM12L	3xDR12L

Ratings are valid at 1025 V nominal DC bus voltage

I_N Nominal (thermal) current. Dimensioning according I_N if the process does not require overloadability

I_L Low overload – 110% overload – 1 min every 5 min

I_H High overload – 150% overload for 1 min every 5 min

$P_{L\text{-typ}}$ is the DC source power with the stated source voltage and I_L current

DC bus current rating is equal to DC source current ratings (DC current)

Source voltage range 3..100% of DC bus voltage. Full control performance 3..97% of DC bus voltage

DC/DC Converter (DC) ratings at 800 V DC

iC7-60SLDCB5, 465-800 V DC bus, IP00/UL Open Type DC/DC Converter

Product code	DC current			DC power	Frame	Frame with option +AE_
	I_N	I_L	I_H	700..250 $V_{DC \text{ source}}$		
				$P_{L\text{-typ}}$		
[A]	[A]	[A]	[kW]			
iC7-60SLDCB5-300AE00F4	307	300	225	210..75	DM10L	DR10L
iC7-60SLDCB5-360AE00F4	368	360	270	252..90	DM10L	DR10L
iC7-60SLDCB5-420AE00F4	429	420	315	294..105	DM10L	DR10L
iC7-60SLDCB5-480AE00F4	490	480	360	336..120	DM10L	DR10L
iC7-60SLDCB5-570AE00F4	582	570	428	399..143	DM10L	DR10L
iC7-60SLDCB5-720AE00F4	735	720	540	504..180	DM12L	DR12L
iC7-60SLDCB5-840AE00F4	858	840	630	588..210	DM12L	DR12L
iC7-60SLDCB5-960AE00F4	980	960	720	672..240	DM12L	DR12L
iC7-60SLDCB5-1080E00F4	1103	1080	810	756..270	DM12L	DR12L
iC7-60SLDCB5-1200E00F4	1225	1200	900	840..300	DM12L	DR12L
iC7-60SLDCB5-1440E00F4	1470	1440	1080	1008..360	2xDM12L	2xDR12L
iC7-60SLDCB5-1680E00F4	1715	1680	1260	1176..420	2xDM12L	2xDR12L
iC7-60SLDCB5-1920E00F4	1960	1920	1440	1344..480	2xDM12L	2xDR12L
iC7-60SLDCB5-2160E00F4	2205	2160	1620	1512..540	2xDM12L	2xDR12L
iC7-60SLDCB5-2400E00F4	2450	2400	1800	1680..600	2xDM12L	2xDR12L
iC7-60SLDCB5-2880E00F4	2940	2880	2160	2016..720	3xDM12L	3xDR12L
iC7-60SLDCB5-3240E00F4	3308	3240	2430	2268..810	3xDM12L	3xDR12L
iC7-60SLDCB5-3600E00F4	3675	3600	2700	2520..900	3xDM12L	3xDR12L

Ratings are valid at 800 V DC voltage

I_N Nominal (thermal) current. Dimensioning according I_N if the process does not require overloadability

I_L Low overload – 110% overload – 1 min every 5 min

I_H High overload – 150% overload for 1 min every 5 min

$P_{L\text{-typ}}$ is the DC source power with the stated source voltage and I_L current

DC bus current rating is equal to DC source current ratings (DC current)

Source voltage range 3..100% of DC bus voltage. Full control performance 3..97% of DC bus voltage



Dimensions and weight: INU, AFE, GC and DC/DC modules

Module type		Inverter		AFE and Grid Converter		Inverter with integration unit		AFE/Grid Converter with integration unit		DC/DC Converter		DC/DC Converter with integration unit	
Frame		IM10L	IM12L	AM10L	AM12L	IR10L	IR12L	AR10L	AR12L	DM10L	DM12L	DR10L	DR12L
[mm]	Width	140	235	140	235	140	235	140	235	140	235	140	235
	Height	710	710	710	710	1295	1295	1295	1295	710	710	1295	1295
	Depth	558	558	558	558	566	566	566	566	558	558	566	566
[kg]	Weight ¹⁾	41	80	41	80	106	178	138	230	41	80	130	230
[in]	Width	5.5	9.3	5.5	9.3	5.5	9.3	5.5	9.3	5.5	9.3	5.5	9.3
	Height	28	28	28	28	51	51	51	51	28	28	51	51
	Depth	22	22	22	22	22.3	22.3	22.3	22.3	22	22	22.3	22.3
[lb]	Weight ¹⁾	90	176	90	176	234	392	304	507	90	176	287	507

¹⁾Weight includes integration unit with these filters installed:
 IR10L, IR12L with dU/dt filter (+AEU1)
 IR12L with sine-wave filter (+AES1): weight 222 kg
 AR10L, AR12L with LC filter (+AEZ1)
 DR10L, DR12L with DC/DC filter (+AED1)

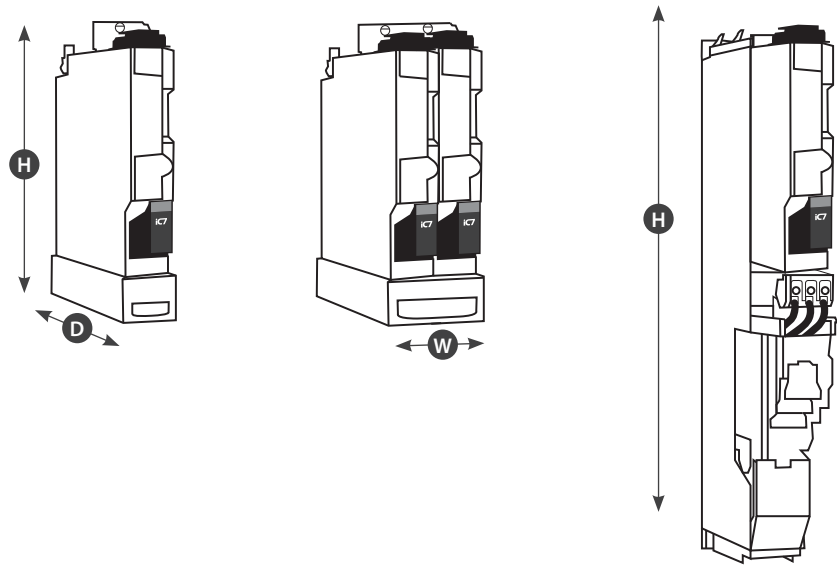

Filters

Type	
Input filters	LC-filter and LCL-filter for Active front end and Grid converter modules
Output filters	dU/dt filter for inverter module (INU)
	Sine-wave filter for inverter module (INU)
	Common-mode filter for inverter module (INU), frame IR10L
DC/DC filter	DC/DC filter for DC/DC converter modules
Filter features	IP00 (IP55 excluding power terminals)
	Dedicated liquid cooled filters with up to 90% of heat losses to liquid Very low losses to air reduce air conditioning load
	Unsurpassed power density, ultra compact, super lightweight filter concept – unmatched anywhere in the market
	Supports vertical and horizontal mounting

Filters are available integrated in the integration unit and separately as loose options, which enables low-height installations





The Danfoss logo is written in a white, cursive script font on a red rectangular background.

ENGINEERING
TOMORROW



Imagine versatile and highly secure power conversion and motor control. Intensely powerful and compact converters and drives built to optimize a vast range of systems while giving you the flexibility to distribute intelligence the way you want. Paving the way for a new dimension, where open, connected and intelligent systems are the new reality.



 **Open up a new dimension with iC7 series**
iC7-Automation | iC7-Marine | iC7-Hybrid

Contact us 

AD503139556287en-000102 | © Copyright Danfoss Drives | 2024.12

Any information, including, but not limited to information on selection of product, its application or use, product design, weight, dimensions, capacity or any other technical data in product manuals, catalogues descriptions, advertisements, etc. and whether made available in writing, orally, electronically, online or via download, shall be considered informative, and is only binding if and to the extent, explicit reference is made in a quotation or order confirmation. Danfoss cannot accept any responsibility for possible errors in catalogues, brochures, videos and other material. Danfoss reserves the right to alter its products without notice. This also applies to products ordered but not delivered provided that such alterations can be made without changes to form, fit or function of the product. All trademarks in this material are property of Danfoss A/S or Danfoss group companies. Danfoss and the Danfoss logo are trademarks of Danfoss A/S. All rights reserved.