

ENGINEERING
TOMORROW



Design Guide

iC7 Series Air-cooled System Modules

Active Front-End, Grid Converter, and Inverter Modules



drives.danfoss.com |



Contents

1 Introduction

1.1 Purpose of this Design Guide	9
1.2 Additional Resources	9
1.3 Planning and Design Support Materials	9
1.3.1 Overview	9
1.3.2 Locating Support Information	9
1.4 Version History	10
1.5 Abbreviations	10
1.6 Recommended Disposal	11

2 Safety

2.1 Safety	12
2.2 Safety Symbols	12
2.3 General Safety Considerations	12
2.4 Target Group and Necessary Qualifications	13

3 Danfoss iC7 Series

3.1 Overview of iC7 Series	14
----------------------------	----

4 Overview of the iC7 Series Air-cooled System Modules

4.1 System Modules	15
4.2 Contents of the Delivery	15
4.3 Checking the Delivery	16
4.4 Description of the Frame Designation	16
4.5 Weights of the System Modules	16
4.6 Lifting the Product	17
4.7 Common DC-bus Drive System	18
4.8 Control System of the System Modules	20
4.9 Description of the Model Code	20
4.10 Options	21
4.11 Labels on the System Module	23
4.12 Labels on Other Components	23
4.13 Product Label	24

5 Mechanical Installation Considerations

5.1 Storing the System Module	26
5.2 Requirements for the Cabinet	26
5.3 Installation Direction	26
5.4 Installation Requirements	27
5.5 Installing System Modules into Cabinet	27
5.6 Installing Inverter Modules with Integration Units into Cabinet	29
5.7 Installing LCL Filters and AFE Modules with Integration Units into Cabinet	32
5.8 Cooling Requirements	34
5.8.1 General Cooling Requirements	34
5.8.2 The Quantity of Cooling Air	35
5.8.3 Cooling of System Modules	35
5.8.4 Cooling of System Modules with Integration Units	36
5.8.5 Steering the Airflow	37

6 Electrical Installation Considerations

6.1 Cable Requirements	38
6.2 Grounding Principles	38
6.3 Grounding the Products	39
6.4 Prerequisites for Cable Installation	39
6.5 Recommended Installation of Motor Cables	41
6.6 Cable Requirements for the LCL Filter Fan Supply	41
6.7 Connecting the LCL Filter Fan Supply	42
6.8 Installation in an Impedance-grounded (IT) System	43
6.9 Changing the EMC Protection Level in an IT System	45
6.10 Fuses of the Drive System	47
6.11 Guidelines for DC Connections of System Modules	47
6.12 Terminals of the System Modules	48
6.13 Auxiliary Power Connection of the Power Unit	49
6.14 AuxBus Communication	50
6.14.1 Usage of AuxBus	50
6.14.2 AuxBus Cable Requirements	51
6.14.3 AuxBus Grounding Principles	52
6.14.4 AuxBus Terminals of the LCL Filter and the Integration Unit	53

7 Options and Accessories for the Air-cooled System Modules

7.1 dU/dt Filter	55
7.2 Common-mode Filter	55
7.3 LCL Filter	56
7.4 The Pre-charging Unit	56

8 Control Unit

8.1 Modular Control Unit	58
8.2 Control Board	59
8.3 Definitions of the Indicator Lights on the Control Board	60
8.4 Control Board Connections	60
8.5 Star Coupler Board	62
8.6 Definitions of the Indicator Lights on the Star Coupler Board	64
8.7 Star Coupler Board Connections	65
8.8 I/O and Relay Option Connections	65
8.9 I/O and Relay Option Interface	68
8.9.1 Analog Inputs	68
8.9.2 Analog Outputs	68
8.9.3 Digital Inputs	69
8.9.4 Digital Outputs	70
8.9.5 Relay Outputs	70
8.9.6 Analog Reference Voltage Output	71
8.9.7 24 V DC Voltage Output	71
8.9.8 Thermistor Input	71
8.10 Assembling the Control Unit Mounting Plates	71
8.11 Attaching the Control Unit Mounting Plates	72
8.12 Installing the Control Unit	73
8.13 Installing Boards to the Modular Control Unit	73
8.14 Connecting the Fieldbus Cable and the Fiber Cables	74
8.15 Installing the Control Cables into the Control Terminals	74
8.16 Connecting the Control Panel	75
8.17 Fiber Cable Requirements	75

9 Maintenance

9.1 Preventive Maintenance Recommendations	77
9.2 Using the Product Modified Label	79
9.3 Replacing the RTC Battery	79
9.4 Removing the Fan Assembly	80
9.5 Installing MyDrive® Insight	82
9.6 Downloading the Software without the Mains Supply	82
9.7 Recommissioning of the Drive	82

10 Specifications

10.1 Tightening Torques	84
10.2 Dimensions	84
10.2.1 Dimensions of the Inverter Module, IM10	84
10.2.2 Dimensions of the Inverter Module, IM11	85
10.2.3 Dimensions of the Inverter Module, IR10	86
10.2.4 Dimensions of the Inverter Module, IR10 with Short Integration Unit (+AE01)	87
10.2.5 Dimensions of the Inverter Module, IR11	88
10.2.6 Dimensions of the Inverter Module, IR11 with Short Integration Unit (+AE01)	89
10.2.7 Dimensions of the AFE Module, AR10	90
10.2.8 Dimensions of the AFE Module, AR10, with the Short Integration Unit (+AE01)	91
10.2.9 Dimensions of the AFE Module, AR11	92
10.2.10 Dimensions of the AFE Module, AR11, with the Short Integration Unit (+AE01)	93
10.2.11 Dimensions of the LCL Filter, LCL10, and the AFE Module, AR10	94
10.2.12 Dimensions of the LCL Filter, LCL10, and the AFE Module, AR10, with the Short Integration Unit (+AE01)	95
10.2.13 Dimensions of the LCL Filter, LCL11, and the AFE Module, AR11, with the Standard Integration Unit (+AE10)	96
10.2.14 Dimensions of the LCL Filter, LCL11, and the AFE Module, AR11, with the Short Integration Unit (+AE01)	97
10.2.15 Dimensions of the LCL Filter, LCL11W, and the AFE Module, AR11, with the Standard Integration Unit (+AE10)	98
10.2.16 Dimensions of the LCL Filter, LCL11W, and the AFE Module, AR11, with the Short Integration Unit (+AE01)	99
10.2.17 Dimensions of the LCL Filter, LCL10 (514 A) and LCL11 (816 A)	100
10.2.18 Dimensions of the LCL Filter, LCL11W (820 A)	101
10.2.19 Dimensions of the Short Integration Unit for AFE Module (+AE01)	102
10.2.20 Dimensions of the Standard Integration Unit for AFE Module (+AE10)	103
10.2.21 Dimensions of the Short Integration Unit for Inverter Module (+AE01)	104
10.2.22 Dimensions of the Standard Integration Unit for Inverter Module (+AE10)	105
10.2.23 Dimensions for DC Fuses, IM10	107

10.2.24	Dimensions for DC Fuses, IM11	108
10.2.25	Dimensions for DC Fuses, IR10	109
10.2.26	Dimensions for DC Fuses, IR11	110
10.2.27	Dimensions of the Control Unit	111
10.2.28	Dimensions of the Control Unit Mounting Plate	112
10.2.29	Dimensions of the Option Connector	113
10.2.30	Dimensions of the Control Board	114
10.2.31	Dimensions of the I/O and Relay Option	115
10.2.32	Dimensions of an Option Board	116
10.2.33	Dimensions of the 4-port Star Coupler Board	117
10.2.34	Dimensions of the 8-port Star Coupler Board	118
10.2.35	Dimensions of the 16-port Star Coupler Board	119
10.2.36	Dimensions of the Pre-charging Unit, IEC	120
10.2.37	Dimensions of the Pre-charging Unit, UL	121
10.3	Wiring Diagrams	121
10.3.1	Wiring Diagram, AFE Modules	121
10.3.2	Wiring Diagram, AFE Modules with Parallel Power Units	122
10.3.3	Wiring Diagram, Inverter Modules	123
10.3.4	Wiring Diagram, Inverter Modules with Parallel Power Units	123
10.3.5	Pre-charging Wiring Diagram, AFE Modules	124
10.3.6	Pre-charging Control Wiring Diagrams	125
10.3.7	The Pre-charging Function	126
10.3.8	Wiring Diagrams of the +24 V Supply for the Control Unit	127
10.4	Cable Sizes	128
10.4.1	General Cable Size Information	128
10.4.2	Mains Cable Size Recommendations for AFE Modules, 380–500 V	129
10.4.3	Motor Cable Sizes Recommendation for Inverter Modules, 380–500 V	130
10.4.4	Motor Cable Size Recommendations for Inverter Modules with Integration Units, 380–500 V	131
10.4.5	Mains Cable Size Recommendations for AFE Modules, UL 480 V	131
10.4.6	Motor Cable Sizes Recommendation for Inverter Modules, UL 480 V	132
10.4.7	Motor Cable Size Recommendations for Inverter Modules with Integration Units, UL 480 V	133
10.5	Fuses	134
10.5.1	List of Fuse Size Information	134
10.5.2	AC Fuses for AFE, 380–500 V AC	134
10.5.3	DC Fuses for AFE, 465–740 V DC	135
10.5.4	DC Fuses for Inverter Modules, 465–740 V DC	136

10.6	Current Ratings	137
10.6.1	General Current Rating Information	137
10.6.2	Current Ratings for Regenerative AFE Module, 400 V AC (465–650 V DC)	138
10.6.3	Current Ratings for Regenerative AFE Module, UL 480 V AC (650–740 V DC)	138
10.6.4	Current Ratings for Regenerative AFE Module, 500 V AC (650–740 V DC)	139
10.6.5	Current Ratings for Low-harmonic AFE Module, 400 V AC (465–650 V DC)	140
10.6.6	Current Ratings for Low-harmonic AFE Module, UL 480 V AC (650–740 V DC)	141
10.6.7	Current Ratings for Low-harmonic AFE Module, 500 V AC (650–740 V DC)	141
10.6.8	Current Ratings for Inverter Module, 400 V AC (465–650 V DC)	142
10.6.9	Current Ratings for Inverter Module, UL 460 V AC (650–740 V DC)	143
10.6.10	Current Ratings for Inverter Module, 500 V AC (650–740 V DC)	144
10.6.11	Current Ratings for Grid Converter Module, 400 V AC (465–650 V DC)	145
10.6.12	Current Ratings for Grid Converter Module, 500 V AC (650–740 V DC)	146
10.7	Derating the Output Current	146
10.8	Power Losses	147
10.8.1	General Power Loss Information	147
10.8.2	Power Losses of AFE Modules without Options, 380–440 V	148
10.8.3	Power Losses of AFE Modules without Options, 440–500 V	149
10.8.4	Power Losses of LCL Filter at Drive Nominal Parameters, 380–500 V	150
10.8.5	Power Losses of Inverter Modules without Options, 380–440 V	150
10.8.6	Power Losses of Inverter Modules with dU/dt Filter, 150 m (492 ft) Motor Cables, 380–440 V	151
10.8.7	Power Losses of Inverter Modules without Options, 440–500 V	152
10.8.8	Power Losses of Inverter Modules with dU/dt Filter, 150 m (492 ft) Motor Cables, 440–500 V	153
10.9	Technical Data	154

1 Introduction

1.1 Purpose of this Design Guide

This design guide is intended for qualified personnel, such as:

- Project and systems engineers.
- Design consultants.
- Application and product specialists.

The design guide provides technical information to understand the capabilities of the iC7 drives for integration into motor control and monitoring systems. Its purpose is to provide design considerations and planning data for integration of the drive into a system. It caters for selection of drives and options for a diversity of applications and installations. Reviewing the detailed product information in the design stage enables developing a well-conceived system with optimal functionality and efficiency.

This guide is targeted at a worldwide audience. Therefore, wherever occurring, both SI and imperial units are shown.

1.2 Additional Resources

Additional resources are available to help understand the features, and safely install and operate the iC7 products:

- Safety guides, which provide important safety information related to installing iC7 drives.
- Installation guides, which cover the mechanical and electrical installation of drives, or functional extension options.
- Operating guides, which include instructions for control options, and other components for the drive.
- Application guides, which provide instructions on setting up the drive for a specific end use. Application guides for application software packages also provide an overview of the parameters and value ranges for operating the drives, configuration examples with recommended parameter settings, and troubleshooting steps.
- *Facts Worth Knowing about AC Drives*, available for download on www.danfoss.com.
- Other supplemental publications, drawings, and guides are available at www.danfoss.com.

Latest versions of Danfoss product guides are available for download at www.danfoss.com/en/service-and-support/documentation/.

1.3 Planning and Design Support Materials

1.3.1 Overview

Danfoss provides access to comprehensive product information that supports throughout the product lifecycle.

All iC7 series design guides, installation guides, safety guides, operating guides, and application guides are available for download at www.danfoss.com. It is also possible to order printed guides.

For each iC7 drive or power converter, 2D and 3D drawings, and wiring diagrams are available in standard file formats. EPLAN files with macros, technical data, and 3D models are also provided to support in the system design.

Configuration files for drives or power converters are also available. MyDrive® Suite provides tools that support the entire lifecycle of the product, from system design to service. MyDrive® Suite is available at suite.mydrive.danfoss.com/.

The product configurator helps in the product selection, and when the process has been completed, the tool provides a list of relevant documentation and accessories.

Detailed product information can also be accessed by reading the 2D code on the product label.

1.3.2 Locating Support Information

Additional information is available on the company website.

1. Go to www.danfoss.com.

2. Select *Products*.
3. Select *Drives*.
4. Select the product series, for example *Low-voltage drives* or *System modules*.
5. Select the product series (for example, *iC7*).

 The browser opens the product page, which provides links to documents, drawings, and software of the product.

1.4 Version History

This guide is regularly reviewed and updated. All suggestions for improvement are welcome.

The original language of this guide is English.

Table 1: Version History

Version	Remarks
172F6361A	Design Guide created based on the previous Operating Guide 139Z6812C.
172F6361B	Information on using 6 system modules in parallel. Information on the new LCL filter variant LCL11W. Other small changes throughout the guide.

1.5 Abbreviations

Table 2: Abbreviations, Acronyms, and Symbols

Term	Definition
AC	Alternating current
AFE	Active front-end
AI	Analog input
AO	Analog output
DC	Direct current
DI	Digital input
DO	Digital output
EMC	Electromagnetic compatibility
EN	European standards
ESD	Electrostatic discharge
GC	Grid converter
GND	Ground
I	Current
IEC	International Electrotechnical Commission
INU	Inverter
I/O	Input/output
IP	Ingress protection
IT	Isolé terre

Table 2: Abbreviations, Acronyms, and Symbols (continued)

Term	Definition
LC	Inductor-capacitor
LED	Light-emitting diode
L/R	Time constant for a DC circuit
NC	Normally closed
NEMA	National Electrical Manufacturers Association
NFE	Non-regenerative front end
NO	Normally open
PCB	Printed circuit board
PE	Protective earth
RMS	Root mean square
RTC	Real-time clock
STO	Safe torque off
U	Voltage

1.6 Recommended Disposal

When the product reaches the end of its service life, its primary components can be recycled.

Before the materials can be removed, the product must be disassembled. Product parts and materials can be dismantled and separated. Generally, all metals, such as steel, aluminum, copper and its alloys, and precious metals can be recycled as material. Plastics, rubber, and cardboard can be used in energy recovery. Printed circuit boards and large electrolytic capacitors with a diameter of over 2.5 cm (1 in) need further treatment according to IEC 62635 guidelines. To ease recycling, plastic parts are marked with an appropriate identification code.

Contact your local Danfoss office for further information on environmental aspects and recycling instructions for professional recyclers. End-of-life treatment must follow international and local regulations.

All products are designed and manufactured in accordance with Danfoss company guidelines on prohibited and restricted substances. A list of these substances is available at www.danfoss.com.



This symbol on the product indicates that it must not be disposed of as household waste. Do not dispose of equipment containing electrical components together with domestic waste.

It must be handed over to the applicable take-back scheme for the recycling of electrical and electronic equipment.

- Dispose of the product through channels provided for this purpose.
- Comply with all local and currently applicable laws and regulations.

2 Safety

2.1 Safety

When designing AC drives, some residual dangers cannot be avoided. One example is the discharge time, which must be observed to avoid potential death or serious injury. The discharge time is shown on the danger label on the drive.

For further information on safety precautions related to the installation, operation, or maintenance of products, refer to the product-specific installation, safety, and operating guides.

2.2 Safety Symbols

The following symbols are used in Danfoss documentation.

DANGER

Indicates a hazardous situation which, if not avoided, will result in death or serious injury.

WARNING

Indicates a hazardous situation which, if not avoided, could result in death or serious injury.



CAUTION

Indicates a hazardous situation which, if not avoided, could result in minor or moderate injury.

NOTICE

Indicates information considered important, but not hazard-related (for example, messages relating to property damage).

The guide also includes ISO warning symbols related to hot surfaces and burn hazard, high voltage and electrical shock, and referring to the instructions.

	ISO warning symbol for hot surfaces and burn hazard
	ISO warning symbol for high voltage and electrical shock
	ISO action symbol for referring to the instructions

2.3 General Safety Considerations

WARNING



LACK OF SAFETY AWARENESS

This guide provides important information on preventing injury and damage to the equipment or the system. Ignoring this information can lead to death, serious injury, or severe damage to the equipment.

- Make sure to fully understand the dangers and safety measures present in the application.

⚠ WARNING**ELECTRIC SHOCK**

Drives contain hazardous voltage when a power source is connected to AC or DC terminals. Failure to disconnect all power sources can result in death or serious injury.

- Before performing any electrical work on the drive, disconnect, lock out, and tag out all power sources to the drive.
- There is more than 1 live circuit. See the relevant wiring diagram in the product guide.

⚠ DANGER**DISCHARGE TIME**

The drive contains capacitors, which can remain charged even when the drive is not powered. High voltage can be present even when the warning indicator lights are off.

Failure to wait the specified time after power has been removed before performing service or repair work could result in death or serious injury.

- Stop the drive.
- Disconnect all input and output power sources of the drive (for example permanent magnet type motors, batteries, or DC-link connections to other drives).
- Wait for the capacitors to discharge fully before performing any service on the equipment. The discharge time is 5 minutes. If the device is broken or fuses have tripped, the discharge time is longer.
- Use a measuring device to make sure that there is no voltage, before opening the drive or performing any work on the cables.

⚠ WARNING**UNINTENDED START**

When the drive is connected to a power source, the system may start at any time, causing risk of death, serious injury, and equipment or property damage.

- Stop the drive and motor before configuring parameters.
- Make sure that the drive cannot be started by an external switch, a fieldbus command, an input reference signal from the control panel, or after a cleared fault condition.
- Disconnect the drive from the power source whenever safety considerations make it necessary to avoid unintended start.
- Check that the drive, motor, and any driven equipment are in operational readiness.

2.4 Target Group and Necessary Qualifications

Correct and reliable transport, storage, installation, operation, and maintenance are required for the trouble-free and safe operation of the products. Only qualified personnel are allowed to perform all related activities for these tasks. Qualified personnel are defined as properly trained staff, who are familiar with and authorized to install, commission, and maintain equipment, systems, and circuits in accordance with pertinent laws and regulations. Also, the qualified personnel must be familiar with the instructions and safety measures described in this guide and other relevant guides. Non-qualified electricians are not allowed to perform any electrical installation or troubleshooting activities.

Only Danfoss authorized, qualified personnel are allowed to repair this equipment. Specialized training is required to perform the activities related to repair.

3 Danfoss iC7 Series

3.1 Overview of iC7 Series

The Danfoss iC7 series comprises 3 products that combine hardware and software.

Table 3: The iC7 Series

Product	Product category	Product type	Application software
iC7-Automation	Air-cooled system modules	Active front-end	AFE application
		Inverter	Industry application
	Enclosed drives	Active front-end	AFE application
		Inverter	Industry application
	Frequency converters	Frequency converter	Industry application, Motion application
	iC7-Marine	Liquid-cooled system modules	Active front-end
Inverter			Propulsion & Machinery application
iC7-Hybrid	Liquid-cooled system modules	Grid converter	Grid converter application
		DC/DC converter	DC/DC converter application

Additional application software can be purchased and some application software are only available for a specific hardware variant and product.

There are application guides available for all the application software packages.

4 Overview of the iC7 Series Air-cooled System Modules

4.1 System Modules

The air-cooled system modules come in 2 main mechanical variants: with or without an integration unit. The system modules are a size-optimized solution, and the system modules with integration units are intended for easy installation into cabinets, and provide integrated filters. The system modules with integration units also provide possibility for back-channel cooling.

The protection rating of the power units is IP00, and that is why the drive must be installed in a cabinet or another enclosure after delivery.

The system modules include:

- Regenerative AFE modules
- Low-harmonic AFE modules
- Grid Converter (GC) modules
- Inverter (INU) modules

LCL Filters for the AFE modules are available as separate items.

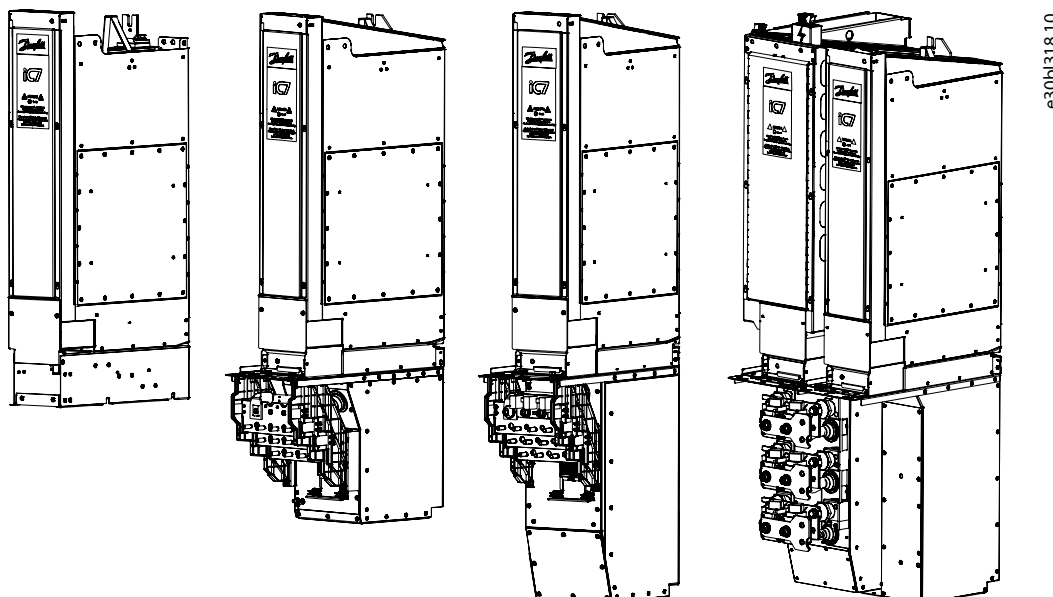

Figure 1: Overview of IM10, and IR10 with a Short and a Standard Integration Unit, and the LCL Filter and the AFE Module

4.2 Contents of the Delivery

The system modules are delivered horizontally on a wooden pallet. The integration unit is delivered in a separate package. Open the package only when the product is installed. It is not recommended to keep power units in storage in the vertical position.

Contents of the Delivery:

- The IP00 power units
- Control unit with ordered options
- A set of optical fiber cables
- Control panel with a cable to control unit (option)
- An accessories bag
- Product documentation
- Integration unit (option +AExx)

4.3 Checking the Delivery

1. Examine the packaging and the product for transport damage.
 - a. If the product was damaged during transport, contact the cargo insurance company or the carrier.
2. Make sure that the items supplied and the information on the product label correspond to the order confirmation.
 - a. If the delivery does not match the order, contact the vendor immediately.

4.4 Description of the Frame Designation

A frame designation is used to refer to different types of iC7 series system modules. The frame designation describes the function, mechanical variant, and size of the system module.

The frame designation can have this format, for example: **IM10**.

Table 4: Description of the Frame Designation

Code	Description
I	Function I = Inverter A = Active front-end/Grid converter
M	Mechanical variant M = System module R = System module with integration unit
10	Size 10 11

4.5 Weights of the System Modules

Table 5: Weights of the System Modules

Frame	No integration unit [kg (lb)]	Short integration unit without filter, +AE01 [kg (lb)]	Short integration unit with CM filter, +AEC1 [kg (lb)]	Standard integration unit without filter, +AE10 [kg (lb)]	Standard integration unit with dU/dt Filter, +AEU1 [kg (lb)]	Standard integration unit with dU/dt and CM filter, +AEU2 [kg (lb)]	Standard integration unit with CM filter, +AEC2 [kg (lb)]	IP00 [kg (lb)]	IP00 with an IP54 cooling channel [kg (lb)]
AM10/ IM10	65 (143.3)	– ⁽¹⁾	–	–	–	–	–	–	–
AM11/ IM11	75 (165.3)	–	–	–	–	–	–	–	–
IR10	–	92 (202.8)	101 (222.7)	95 (209.4)	140 (308.6)	145 (319.7)	109 (240.3)	–	–
IR11	–	102 (224.9)	119 (262.4)	110 (242.5)	185 (407.9)	194 (427.7)	127 (280.0)	–	–
AR10	–	72 (158.7)	–	78 (172.0)	–	–	–	–	–

Table 5: Weights of the System Modules (continued)

Frame	No integration unit [kg (lb)]	Short integration unit without filter, +AE01 [kg (lb)]	Short integration unit with CM filter, +AEC1 [kg (lb)]	Standard integration unit without filter, +AE10 [kg (lb)]	Standard integration unit with dU/dt Filter, +AEU1 [kg (lb)]	Standard integration unit with dU/dt and CM filter, +AEU2 [kg (lb)]	Standard integration unit with CM filter, +AEC2 [kg (lb)]	IP00 [kg (lb)]	IP00 with an IP54 cooling channel [kg (lb)]
AR11	–	82 (180.8)	–	88 (194.0)	–	–	–	–	–
LCL Filter, LCL10	–	–	–	–	–	–	–	221 (487.2)	251 (553.4)
LCL Filter, LCL11	–	–	–	–	–	–	–	290 (639.3)	349 (769.4)
LCL Filter, LCL11W	–	–	–	–	–	–	–	–	329 (725.3)

1) The symbol – in this table means that the value is not applicable.

4.6 Lifting the Product

The weights of system modules and different frames are different. It can be necessary to use a lifting device to move the drive from its package. For lifting the product, follow these instructions.

1. Remove the system module from the pallet where it was bolted to.
2. Use a lifting device that is sufficiently strong for the weight of the system module or filter.
3. Put the lifting hooks in the lifting loop or lifting hole on top of the product.

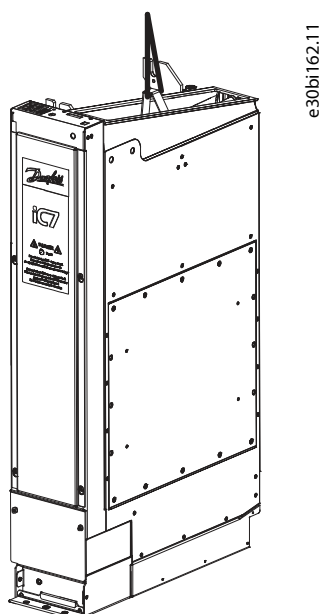

Figure 2: Lifting the System Module

4. Lift the upper part of the LCL Filter for the AFE module vertically or horizontally.

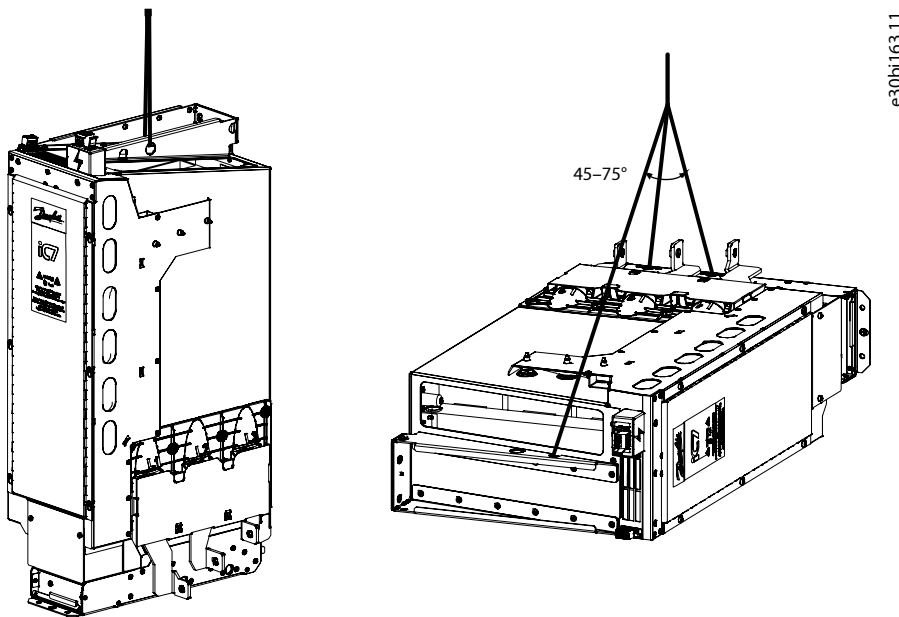

Figure 3: Lifting the Upper Part of the LCL Filter

5. When lifting the integration unit, make sure that the maximum lifting angle is correct ($60^\circ \pm 15^\circ$). Use the 4 lifting holes.

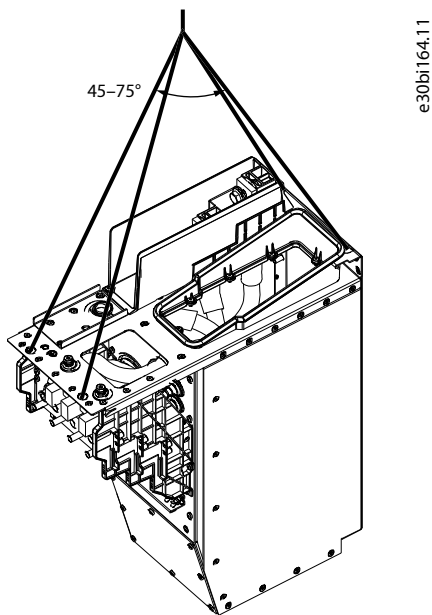

Figure 4: Lifting the Integration Unit

4.7 Common DC-bus Drive System

A common DC-bus drive system consists of 1 or more front-end modules (AFE, GC, or NFE) that convert the mains AC voltage into DC voltage and current, providing power to the common DC bus. A grid converter can also be used to form a local AC grid.

The common DC bus transfers the power to the inverter modules. The regenerative braking energy of an inverter can be used by the other inverters.

A common DC-bus drive system can also include a brake chopper module or a DC/DC converter and an energy storage.

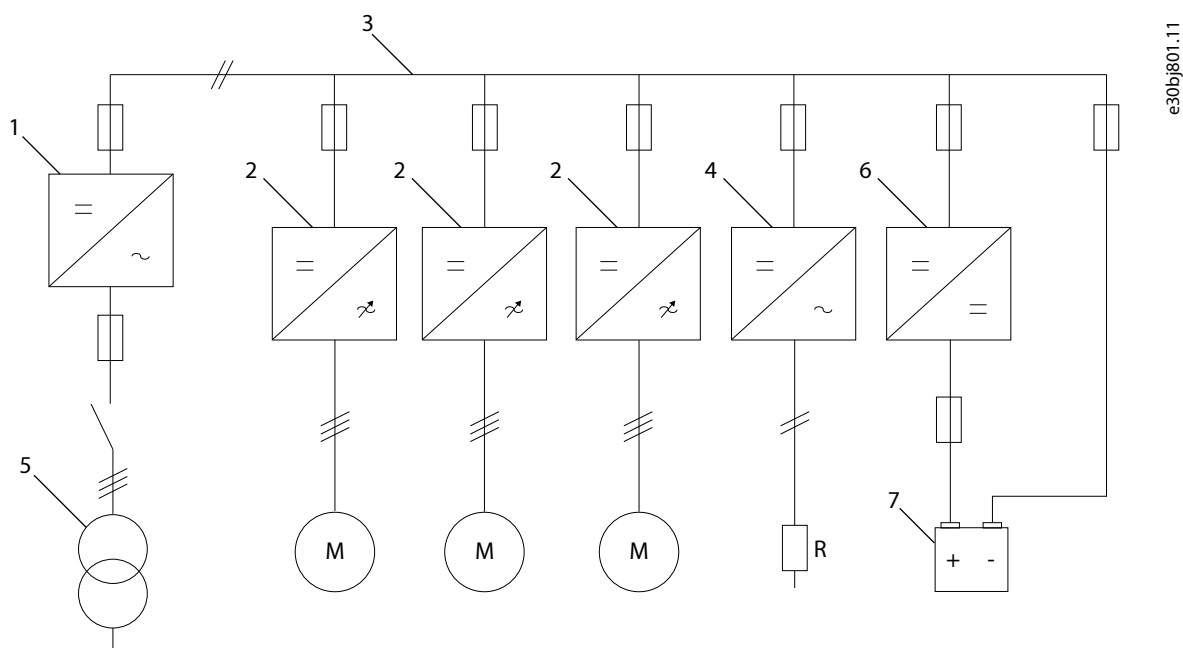
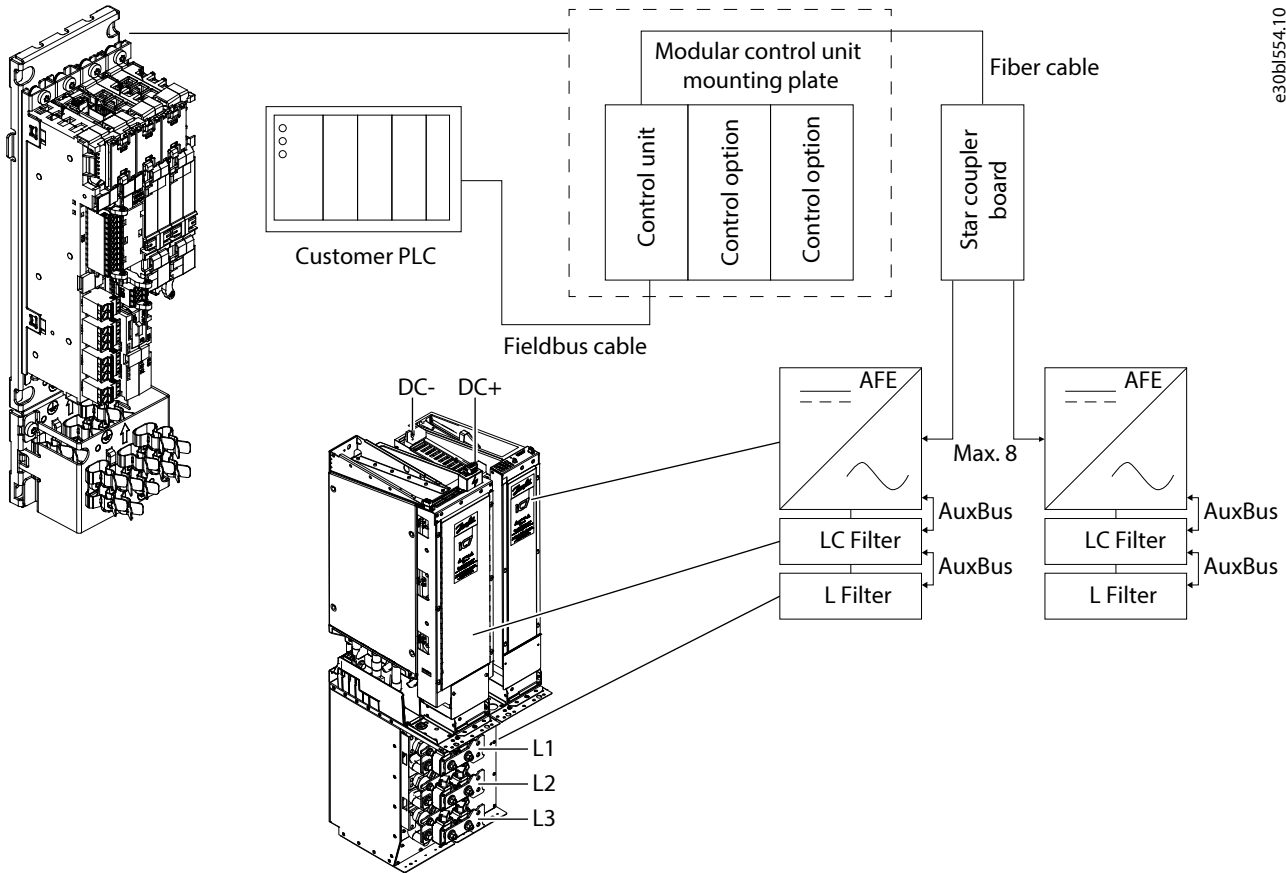

Figure 5: An Example of a Common DC-bus Drive System

1	AFE, GC, or NFE	2	Inverter module
3	DC bus	4	Brake chopper
5	Mains transformer	6	DC/DC converter
7	Energy storage		

4.8 Control System of the System Modules



e30bl554.10

Figure 6: Example of a Control System of an AFE Module and LCL Filter

4.9 Description of the Model Code

The model code defines the specifications of the product included in the delivery. It is shown on the product label and the package label. The model code is made of standard codes and plus codes. Each part of the model code corresponds to the data in the order.

The model code can have this format, for example:

iC7-60SA3A05-816AE00F3+XXXX

Table 6: Description of the Model Code

Code	Description
iC7-60	Product group
SA	Product category SA = system module, air-cooled
3A	Product type 3A = 3~ regenerative AFE 3H = 3~ low-harmonic AFE GC = Grid converter module, GC IN = Inverter module, INU
05	Voltage rating 05 = 380–500 V AC

Table 6: Description of the Model Code (continued)

Code	Description
-816A	Current rating -03A0 = 3 A -816A = 816 A -3000 = 3000 A etc.
E00	Protection rating E00 = IP00/Open Type
F3	EMC category F3 = C3 F4 = C4
+XXXX	Options See 4.10 Options .

4.10 Options

Table 7: Options for the System Modules

Option group	Plus code	Description
Extension, integration unit	+AEXX	None
	+AE01	Short integration unit without filter
	+AEC1	Short integration unit with CM filter
	+AE10	Standard integration unit without filter
	+AEU1	Standard integration unit with dU/dt filter
	+AEU2	Standard integration unit with dU/dt and CM filter
	+AEC2	Standard integration unit with CM filter
Extra environmental protection	+AGCX	Coated boards
Mains input device	+AJXX	None
	+AJFX	AC fuses
DC fuses & devices	+AKXX	None
	+AKFX	DC fuses
Communication interface, X1/X2	+BAEL	Ethernet port, no protocol
	+BAPR	PROFINET RT OS7PR
	+BAMT	Modbus TCP OS7MT
Communication interface, X0	+BBEL	Ethernet port, no protocol
Standard I/O	+BDXX	None
	+BDC1	I/O and Relay Option OC7C1
	+BD00	None, without mounting plate
Functional Safety	+BEXX	None, not upgradable
	+BEF2	STO, SS1-t

Table 7: Options for the System Modules (continued)

Option group	Plus code	Description
Control panel	+BFXX	None
	+BF20	Control Panel 2.8 OPX20
Control panel mounting type	+BGXX	None
	+BGK1	Flush mount
Control panel cable length	+BHXX	None
	+BH15	1.5 m (5 ft)
	+BH25	2.5 m (8 ft)
	+BH50	5.0 m (16 ft)
	+BHA0	10.0 m (32 ft)
Control unit cable length	+BKXX	None
	+BK03	0.3 m (1 ft), fiber
	+BK05	0.5 m (1 ft), fiber
	+BK15	1.5 m (5 ft), fiber
	+BK25	2.5 m (8 ft), fiber
	+BK50	5.0 m (16 ft), fiber
	+BK75	7.5 m (24 ft), fiber
	+BKA0	10.0 m (32 ft), fiber
	+BKA5	15.0 m (50 ft), fiber
Star coupler board cable length	+BLXX	None
	+BL15	1.5 m (5 ft), fiber
	+BL25	2.5 m (8 ft), fiber
	+BL50	5.0 m (16 ft), fiber
	+BL75	7.5 m (24 ft), fiber
	+BLA0	10.0 m (32 ft), fiber
	+BLA5	15.0 m (50 ft), fiber
Control options	+C_XX	None, without mounting plate
	+C_X0	None
	+C_T0	Temperature Measurement OC7T0
	+C_C0	General Purpose I/O OC7C0
	+C_C1	I/O and Relay Option OC7C1
	+C_R0	Relay Option OC7R0
	+C_M0	Encoder/Resolver Option OC7M0
	+C_V0	Voltage Measurement Option OC7V0
Technical documentation	+EGXX	No manuals
	+EGIN	Installation guide
Documentation language	+EHXX	Multi-language
	+EHEN	English

Table 7: Options for the System Modules (continued)

Option group	Plus code	Description
Language pack	+EL01	Global
Shipping package	+TACB	Cardboard box package
	+TASE	Sea container package

4.11 Labels on the System Module

To provide information about the product and the system modules, several labels are placed on the modules.

- Product label
 - Includes the model code and other information about the product. See [4.13 Product Label](#) and [4.9 Description of the Model Code](#).
 - When the product includes several power units, the product label is placed on the left-most power unit, and the other units have only power unit labels.
- Power unit label
 - Includes information about the power unit.
 - The information on the label is specific to each power unit.
- Product modified label
 - List of changes done to the system module.
 - See [9.2 Using the Product Modified Label](#).

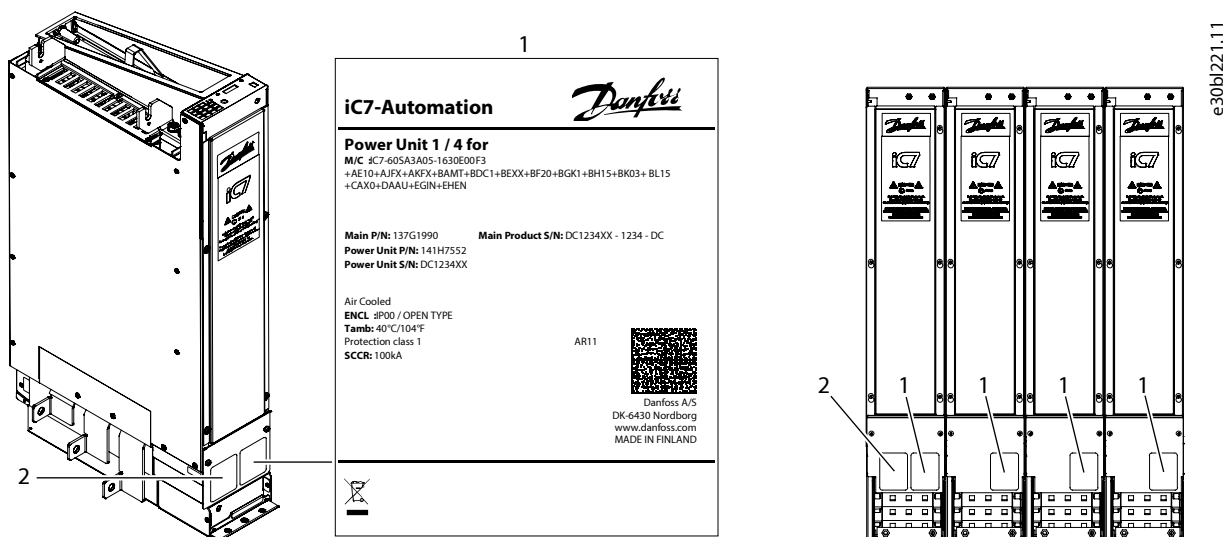

Figure 7: Locations of the Labels on System Modules

1 Power unit label

2 Product label

4.12 Labels on Other Components

There is an identification label on the components to provide information about the part, and information to which product and system modules the component belongs. It is important to match the components with the correct product and system modules.

The identification label on control units and star coupler boards includes:

- Name of the component and information to which system modules the component belongs, for example, "Control for 4xAR12" or "Star for 3xIR10".

- The serial number (S/N) of the product to which the component belongs, for example DC1234XZ. This code is also shown in a small QR code.
- Code for the component, for example 137G2222.
- QR code, which shows the model code of the product, to which this component belongs.

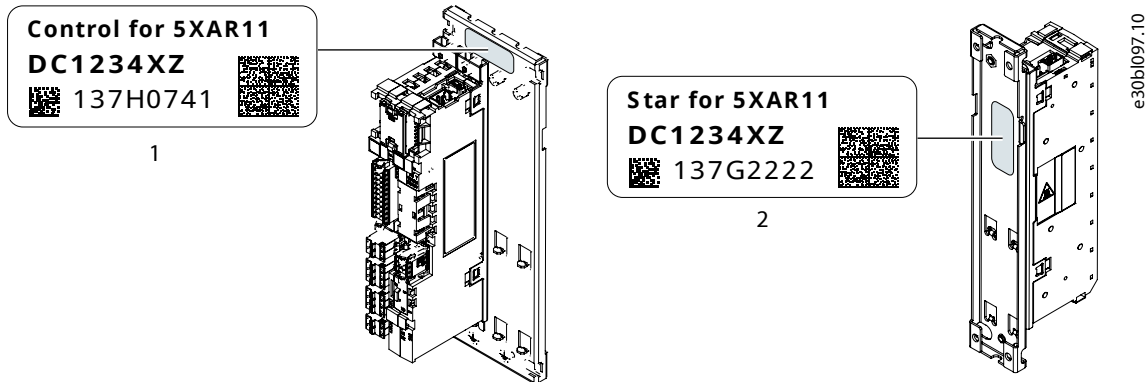

Figure 8: Labels on the Control Unit and Star Coupler Board

1	2
Label on the control unit	Label on the star coupler board

There are similar identification labels on the integration units, filters, and other components. For example, the LCL Filter has a power unit label, like on the system modules. The integration units have an identification label that shows to which system module it belongs.

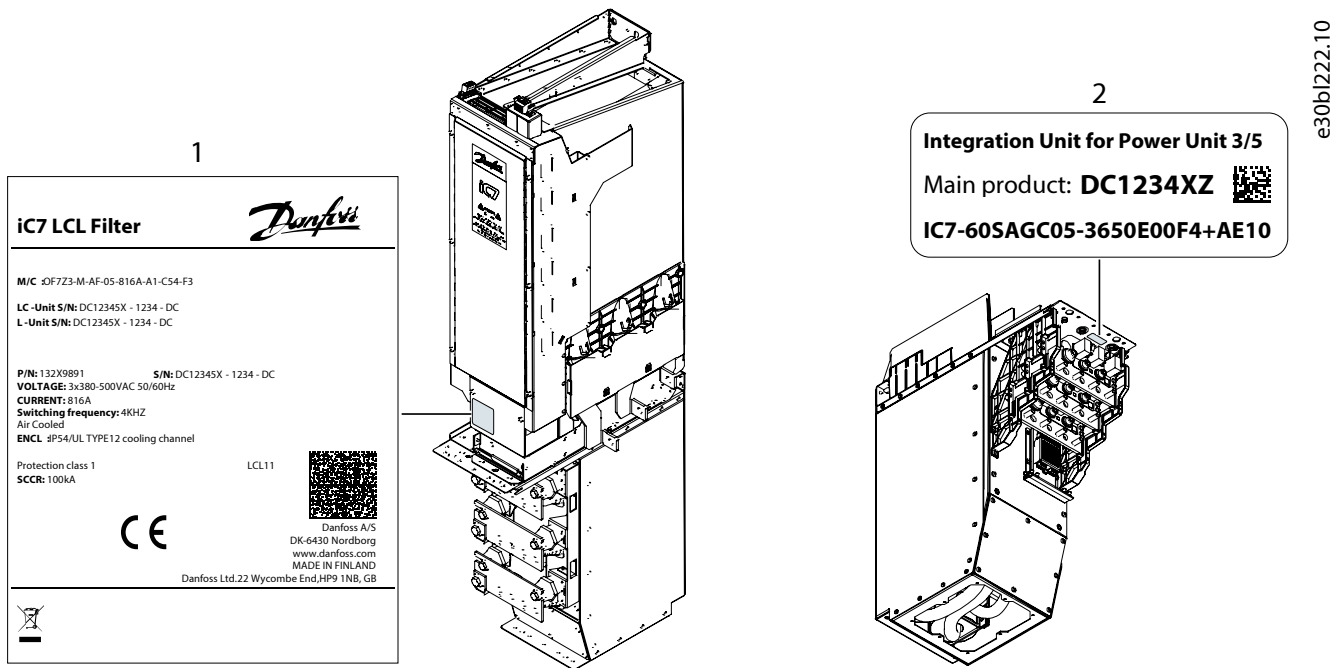

Figure 9: Labels on the LCL Filter and Integration Unit

1	2
Power unit label of LCL Filter	Identification label of integration unit

4.13 Product Label

The product label gives information about the product.

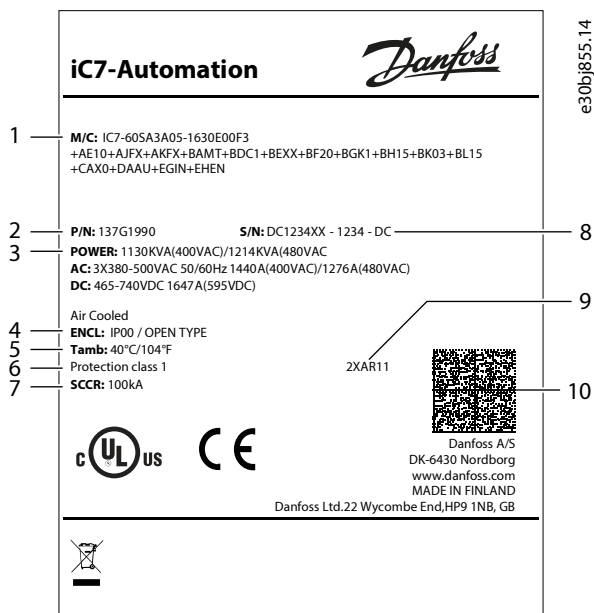

Figure 10: Product Label for iC7 Series Air-cooled System Modules

1	Model code of the product	2	Product number
3	Power, input, and output ratings	4	Protection rating
5	Temperature rating for ambient air	6	Protective class
7	Short-circuit current rating	8	Serial number
9	Frame designation	10	2D code accessible with a Datamatrix ECC 200 compatible barcode reader

5 Mechanical Installation Considerations

5.1 Storing the System Module

If it is necessary to store the product before installing it, follow these instructions. Keep the equipment sealed in its packaging until installation.

1. Make sure that the ambient conditions correspond to these:
 - o Temperature: -40...+70 °C (-40...+158°F)
 - o Humidity: 0...95%, no condensation
2. If the package is kept in storage for more than 2 months, keep it in controlled conditions.
 - a. Make sure that the temperature variation is small.
 - b. Make sure that the humidity is less than 50%.
3. If the package is kept in storage for more than 12 months, connect power to the drive.
 - a. Connect power to the drive.
 - b. Keep the power on for a minimum of 2 hours.
 - c. Disconnect the power.
 - d. Wait for the correct discharge time before removing the drive and storing it again.
4. If the package is kept in storage for several years, reform the capacitors to prevent damage to the capacitors.
 - a. Connect a DC supply with adjustable current limit to the DC+ and DC- terminals.
 - b. Set the current limit (250 mA). If there are parallel power units, multiply the value with the number of power units.
 - c. Set DC voltage ($1.35 * U_n$ AC), where U_n is the drive nominal voltage.
 - d. Keep the power on for a minimum of 1 hour.
 - e. Disconnect the DC supply from the DC+ and DC- terminals.

5.2 Requirements for the Cabinet

The system modules that are described in this guide have the protection rating IP00/Open Type and do not have an enclosure. They must be installed in a cabinet or other enclosure that has a correct level of protection against the ambient conditions in the installation area. Make sure that the cabinet gives protection against water, humidity, dust, and other contaminations. The protection rating of the cabinet must be at least IP21/UL Type 1. The mounting surface of the cabinet must be non-combustible.

The cabinet must also be sufficiently strong to carry the weight of the system module and other devices. It is recommended to use a free-standing, floor-mounted cabinet made of sheet metal.

The maximum temperature of the air inside the cabinet is +60 °C (+140 °F).

When preparing the installation, obey the local regulations.

5.3 Installation Direction

The system modules can be installed in different directions.

NOTICE

INSTALLATION DIRECTION OF SIZE 11 SYSTEM MODULES

The size 11 system modules (IM11, IR11, AM11, AR11) use a heat pipe technology that limits the installation direction. The heat pipes rely on gravitation, thus do not operate fully in certain orientations.

- Do not install the system module on its right side.

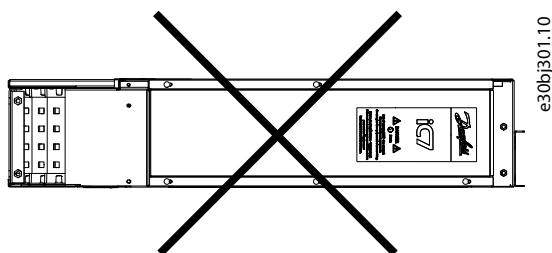

Figure 11: Forbidden Installation Direction of the System Module, Size 11

The system modules with integration units must be installed in a vertical position.

5.4 Installation Requirements

The system modules that are described in this guide have the protection rating IP00/Open Type. Install them in a cabinet or other enclosure that has a correct level of protection against the ambient conditions in the installation area.

The installation procedure varies between product categories and mechanical variants depending on selected options.

Reserve enough space around the system module to ensure sufficient cooling. The mounting plane must be relatively even.

5.5 Installing System Modules into Cabinet

When there are 2 or more system modules, they can be installed side by side.

1. To install the system module, use the mounting holes.

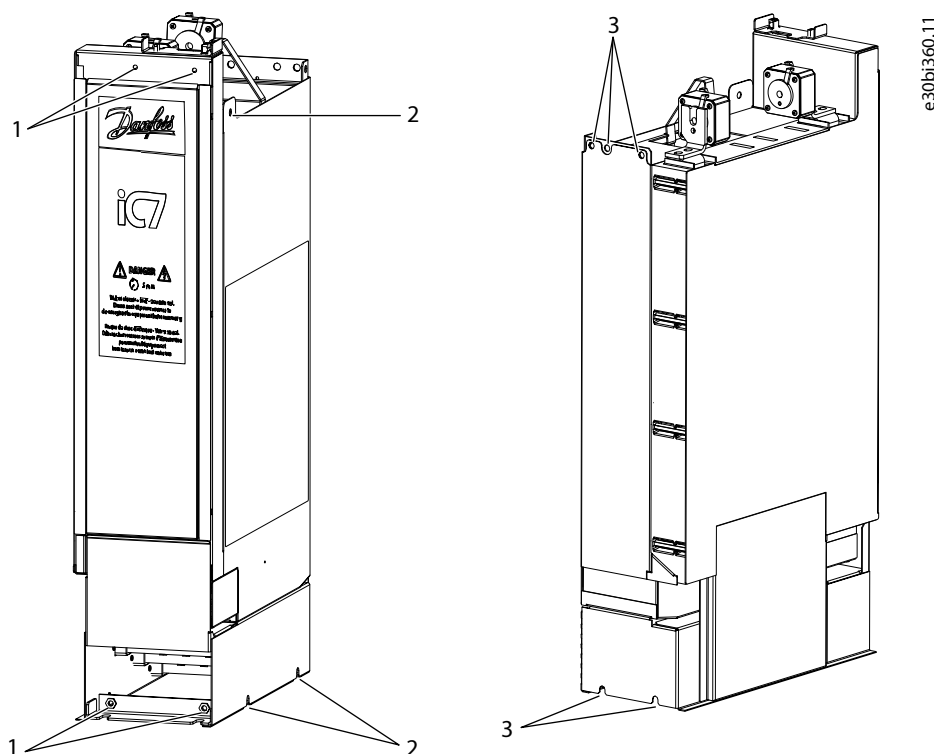

Figure 12: Mounting Holes for IM10, IM11, AM10, AM11

1	Mounting holes at the front	2	Mounting holes at the side
3	Mounting holes at the back		

2. Attach the system module to the back wall of the cabinet and to the front mounting brackets.

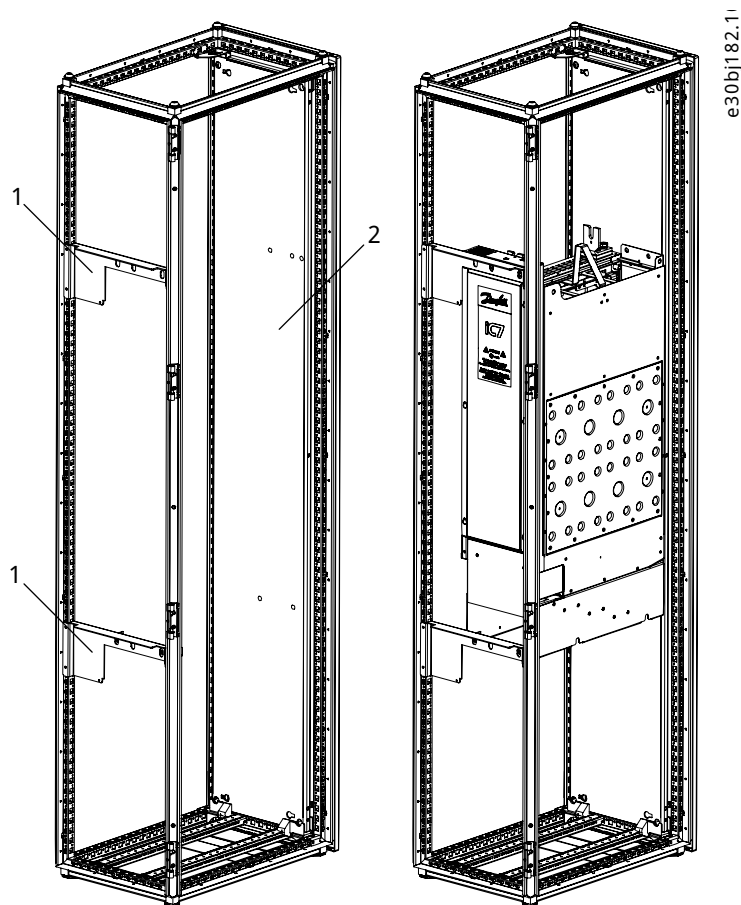

Figure 13: Mounting on the Back Wall, IM10, IM11, AM10, AM11

- | | | | |
|---|-------------------------|---|--------------------------|
| 1 | Front mounting brackets | 2 | Back wall of the cabinet |
|---|-------------------------|---|--------------------------|

3. If the cabinet does not have a back wall, attach the system module to the front and side mounting brackets.

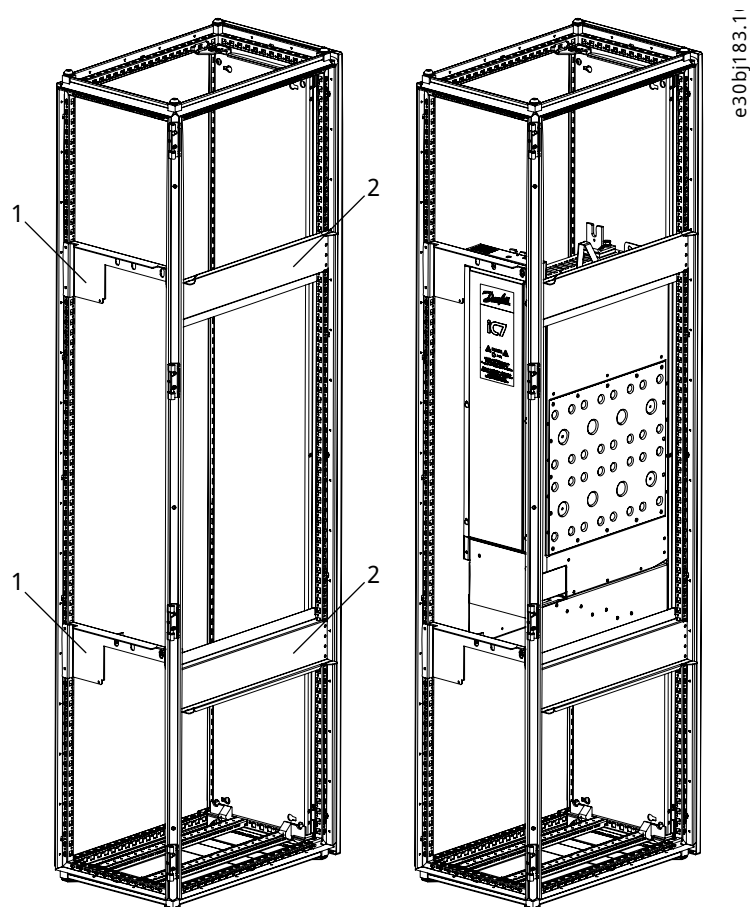

Figure 14: Mounting on the Mounting Brackets, IM10, IM11, AM10, AM11

1	Front mounting brackets	2	Side mounting brackets
---	-------------------------	---	------------------------

5.6 Installing Inverter Modules with Integration Units into Cabinet



RISK OF ELECTRIC SHOCK

Using power units that have AR or IR in their frame designation without integration units will cause death or severe injury.

- Do not use AR10, AR11, IR10, or IR11 power units without integration units.

1. Install mounting brackets to the cabinet.

Mounting brackets are not included in the delivery.

2. Attach the table and the standard integration unit to the front and rear brackets, and to the cabinet floor.

In the front, use countersunk screws.

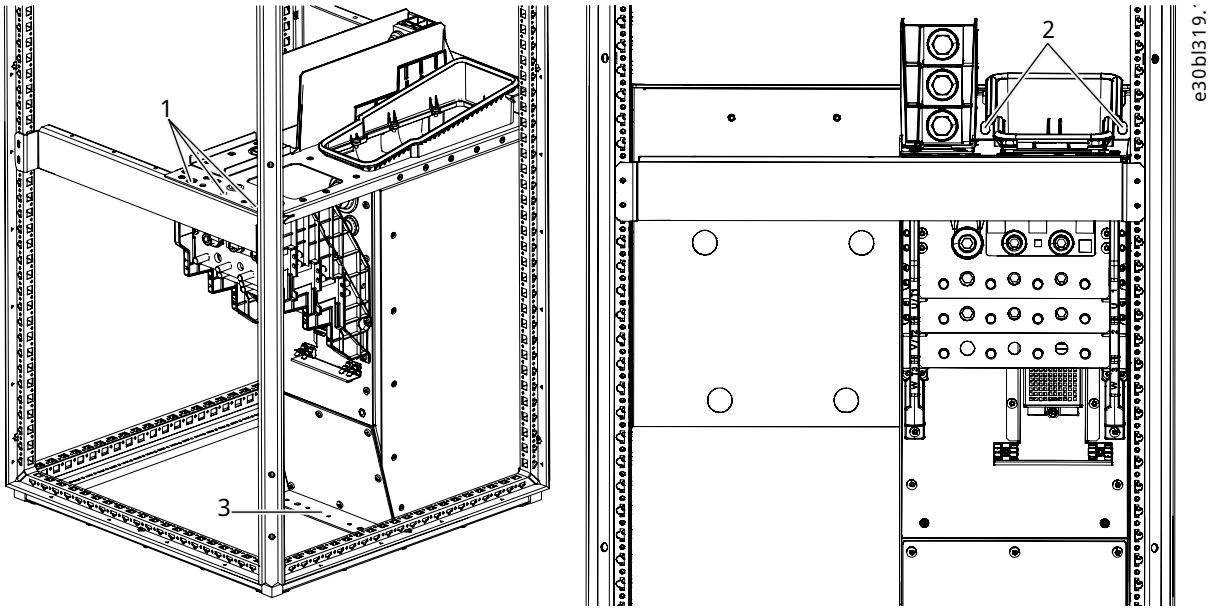

Figure 15: Installing the Standard Integration Unit into the Cabinet, IR10, IR11

- | | |
|--------------------------------|------------------------------|
| 1 Mounting holes at the front | 2 Mounting holes at the back |
| 3 Mounting holes at the bottom | |

3. Attach the short integration unit to the brackets. Attach it from the rear bottom to the rear bracket.

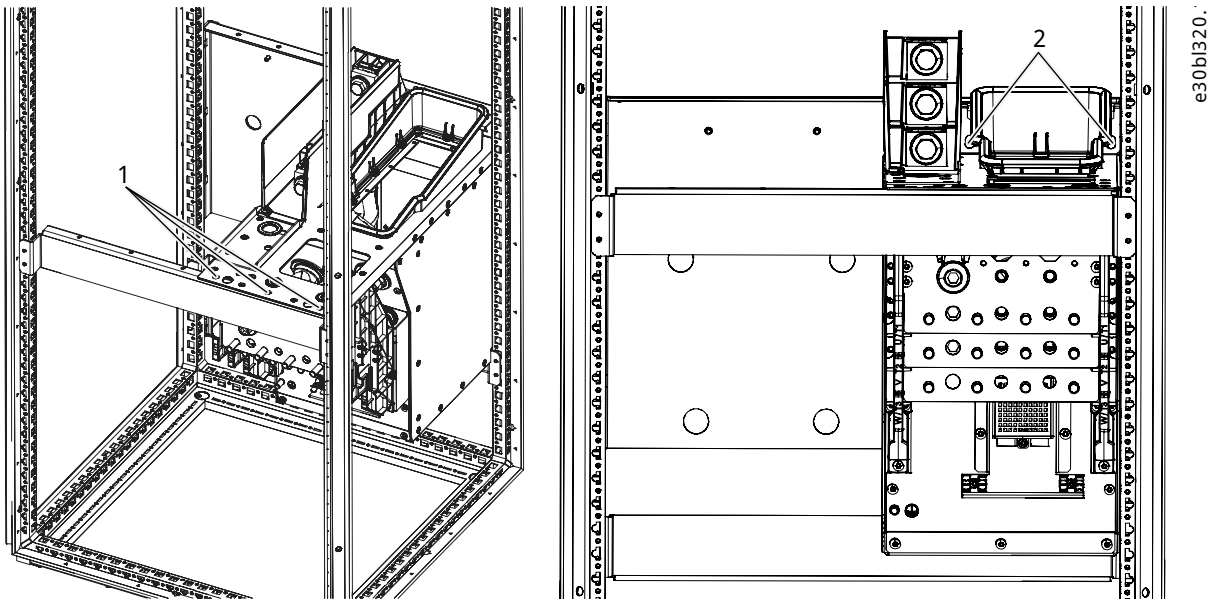

Figure 16: Front and Back Screws of the Short Integration Unit, IR10, IR11

- | | |
|-------------------------------|------------------------------|
| 1 Mounting holes at the front | 2 Mounting holes at the back |
|-------------------------------|------------------------------|

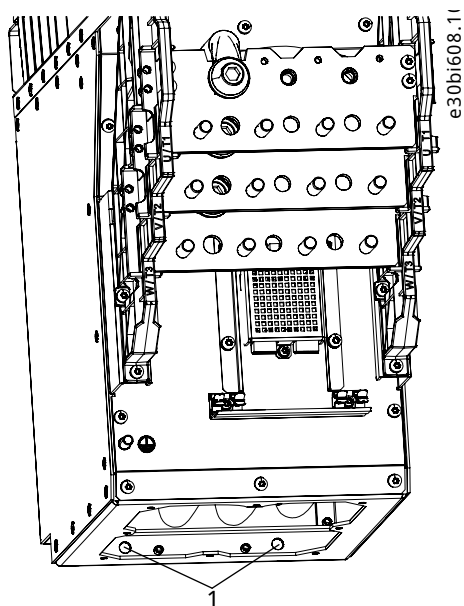

Figure 17: Bottom Screws of the Short Integration Unit, IR10, IR11

1 Mounting holes at the bottom

4. Push and slide the inverter module into the cabinet.
 - a. Add the top front bracket.
 - b. Attach the system module to the table and to the top front bracket (screw M8x20).

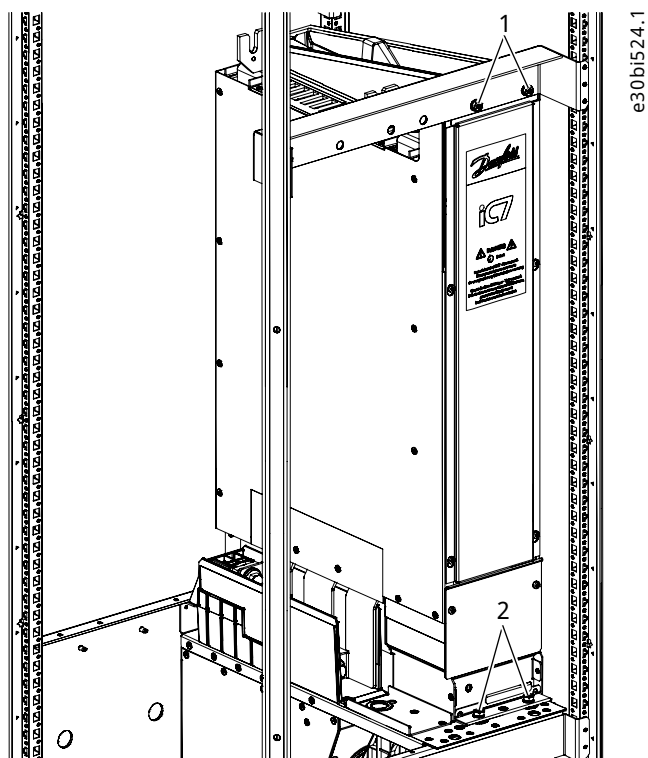

Figure 18: Installing the Inverter Module into the Cabinet, IR10, IR11

1 Upper mounting holes in the front

2 Lower mounting holes in the front

5.7 Installing LCL Filters and AFE Modules with Integration Units into Cabinet



RISK OF ELECTRIC SHOCK

Using power units that have AR or IR in their frame designation without integration units will cause death or severe injury.

- Do not use AR10, AR11, IR10, or IR11 power units without integration units.

1. Install mounting brackets to the cabinet.

Mounting brackets are not included in the delivery.

2. Install the lower part of the LCL Filter into the cabinet.

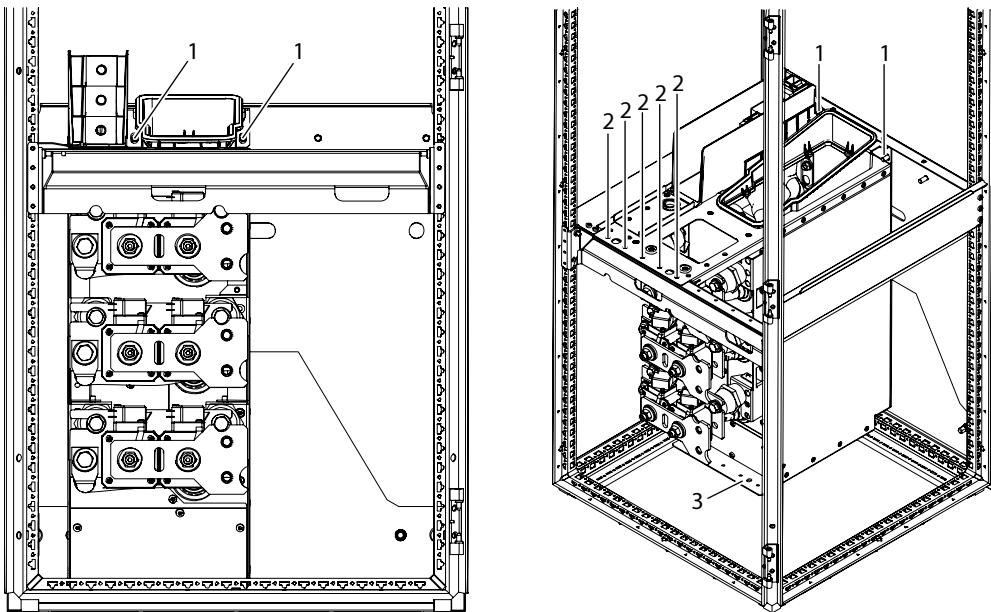

Figure 19: Installing the Lower Part of the LCL Filter

- | |
|--|
| <ol style="list-style-type: none"> 1 Mounting holes at the back 2 Mounting holes at the front 3 Bottom mounting bracket |
|--|

3. Install the integration unit of the AFE module into the cabinet.

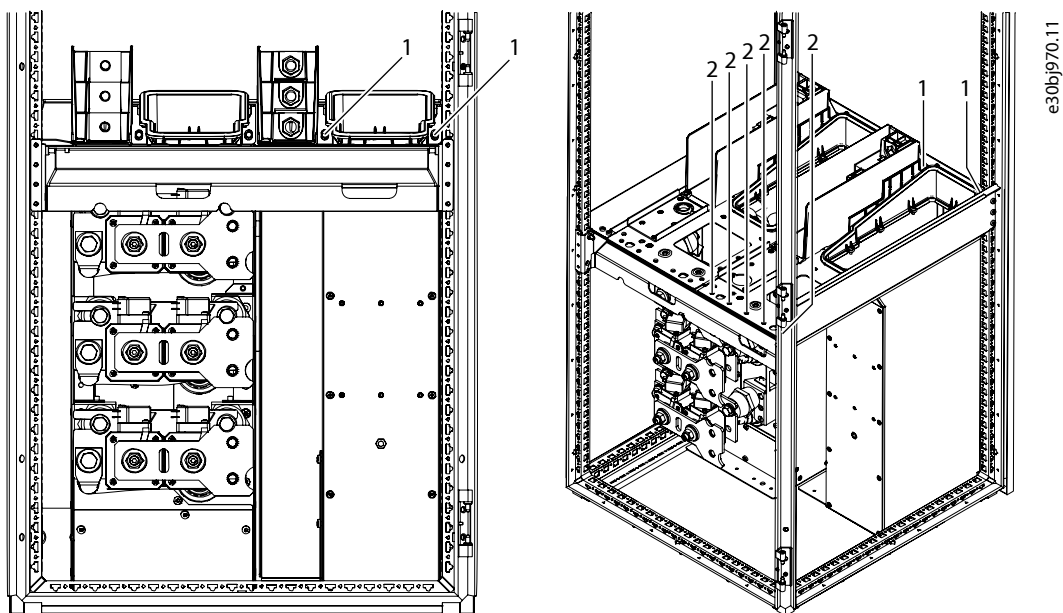

Figure 20: Installing the Integration Unit of the AFE Module, AR10, AR11

- | | |
|----------------------------------|-----------------------------------|
| 1 Mounting holes at the back | 2 Mounting holes at the front |
|----------------------------------|-----------------------------------|

4. Push and slide the upper part of the LCL Filter into the cabinet.

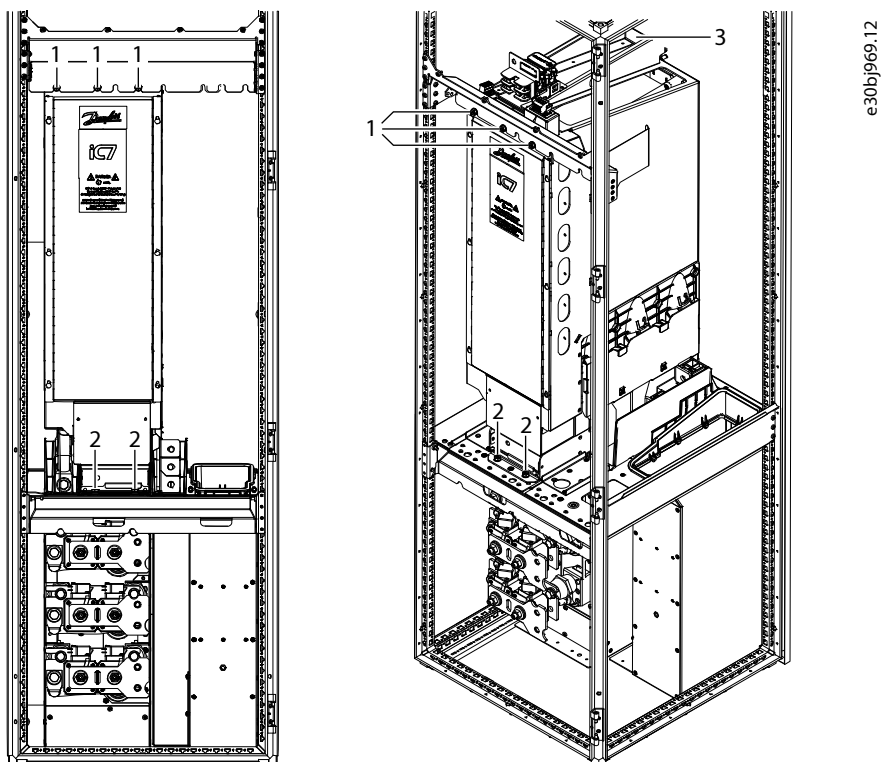

Figure 21: Installing the Upper Part of the LCL Filter

- | | |
|--|---|
| 1 Upper mounting holes at the front | 2 Lower mounting holes at the front |
| 3 The upper mounting holes at the back | |

5. Push and slide the AFE module into the cabinet.

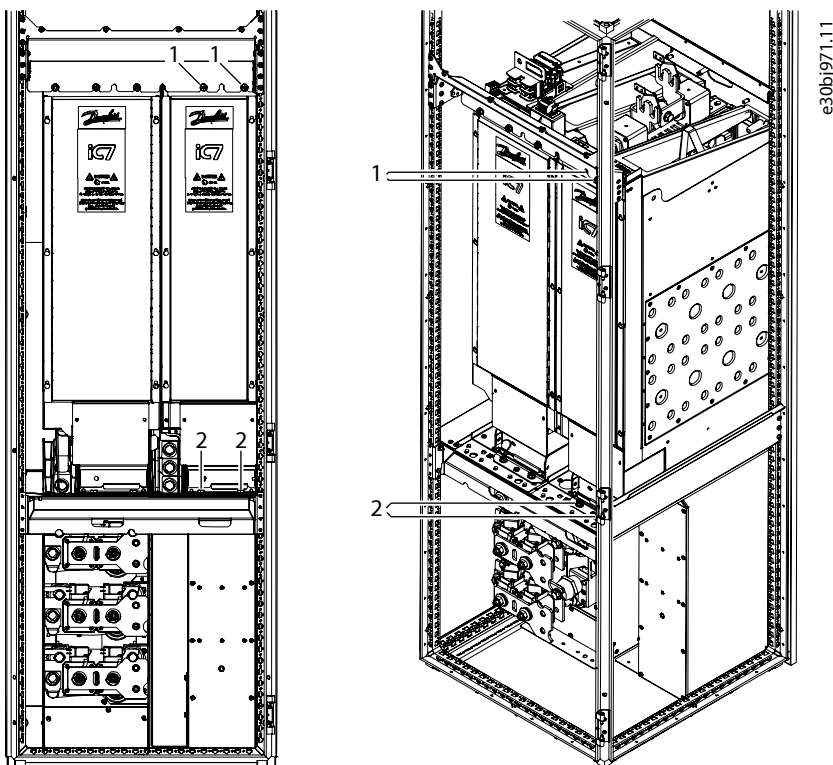

Figure 22: Installing the AFE Module, AR10, AR11

1 Upper mounting holes at the front

2 Lower mounting holes at the front

6. Add the top front bracket.

- a. Attach the upper part of the LCL Filter and the AFE module to the table and to the top front bracket (screw M8x20).

5.8 Cooling Requirements

5.8.1 General Cooling Requirements

The power units produce heat in operation. The fan circulates air and decreases the temperature of the drive. Make sure that there is sufficiently free space around the product.

Some free space in front of the drive is also necessary for maintenance. It must be possible to open the cabinet door. When you have 2 or more system modules, they can be installed side by side.

Make sure that the temperature of the cooling air does not become higher than the maximum ambient operating temperature or lower than the minimum ambient operating temperature of the drive.

The air must move freely and efficiently through the cabinet and the drive. There must be a minimum of 200 mm (8 in) of space above the drive without obstacles that can stop the airflow. Make sure that the hot air goes out of the cabinet and does not recirculate back into the cabinet.

5.8.2 The Quantity of Cooling Air

Table 8: The Necessary Quantity of Cooling Air

Product	The quantity of cooling air [m ³ /h]
Inverter module with dU/dt & CM Filter	870
AFE & inverter modules without options in the integration unit	920
LCL Filter	970

This quantity of cooling air is sufficient for the power unit. If there are other devices that generate heat inside the cabinet, or if more air filters are used (for example to have a higher protection rating), increase the surface area of the air intake holes.

5.8.3 Cooling of System Modules

In the system module without an integration unit, the cooling air is taken from below and exhausted from the top.

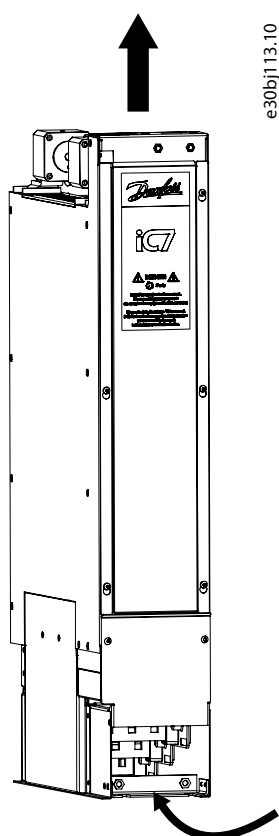

Figure 23: Cooling of System Modules without Integration Units

5.8.4 Cooling of System Modules with Integration Units

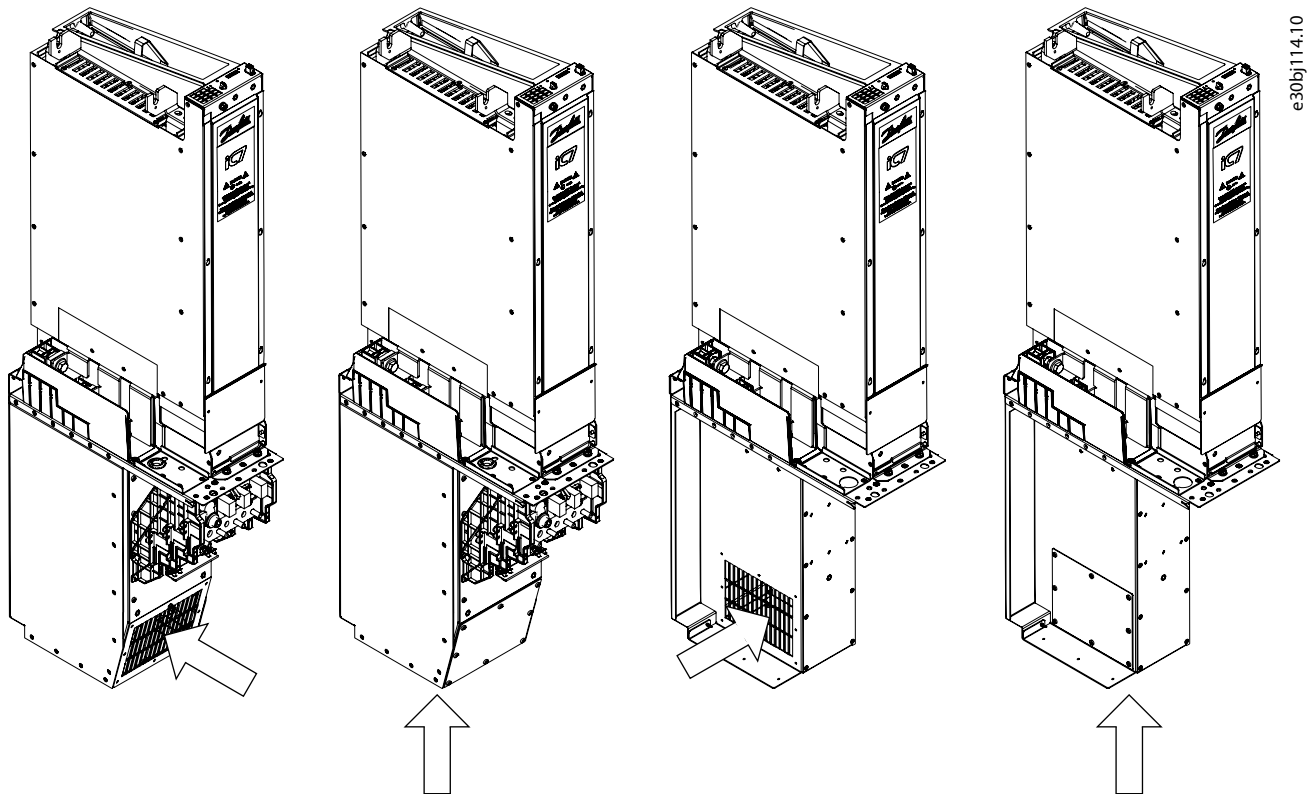

Figure 24: Inlet Airflow from the Front or from Below

In the system modules with integration units, there are 2 methods to arrange inlet and outlet airflow. The inlet airflow can enter from the front or from below of the product. To allow cooling air to enter from the front, remove the air inlet covers of the integration unit.

The outlet airflow can exit the system module directly from the top or through a top duct. The top duct is available as an accessory. Attach the top duct to the cabinet roof and back wall.

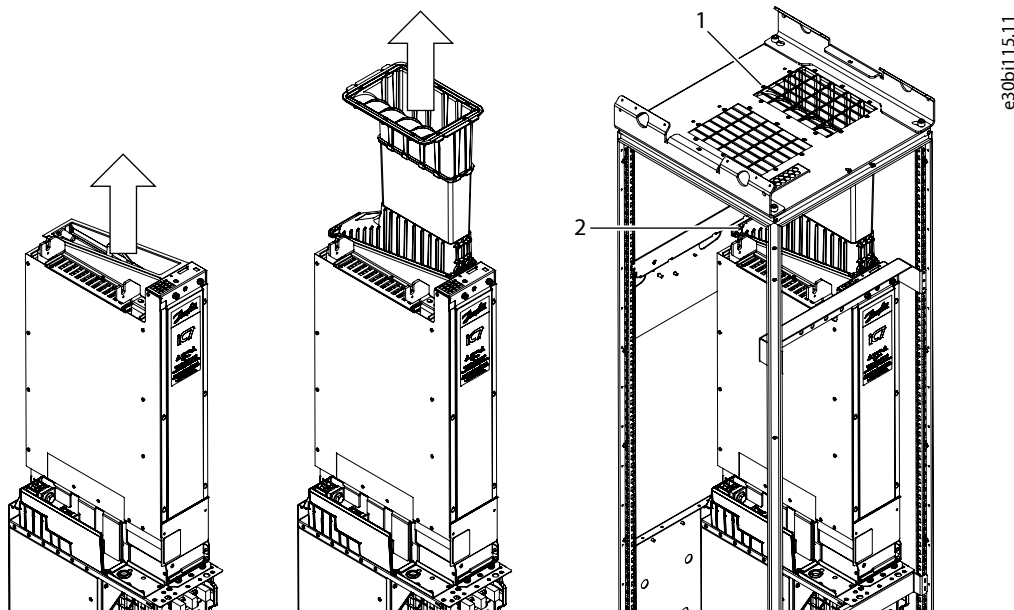

Figure 25: Outlet Airflow with or without a Top Duct

1 Top duct mounted to roof of cabinet

2 Top duct mounted to back wall of cabinet

5.8.5 Steering the Airflow

Cooling air must be taken in through the ventilation gaps on the door and blown out at the top of the enclosure. To steer the hot air from the power unit to the outlet at the top of the enclosure and prevent it from circulating back, follow these instructions.

1. Install air guides in the gaps between the power unit and the cabinet walls. Place the air guides below the air outlet gaps at the sides of the module.

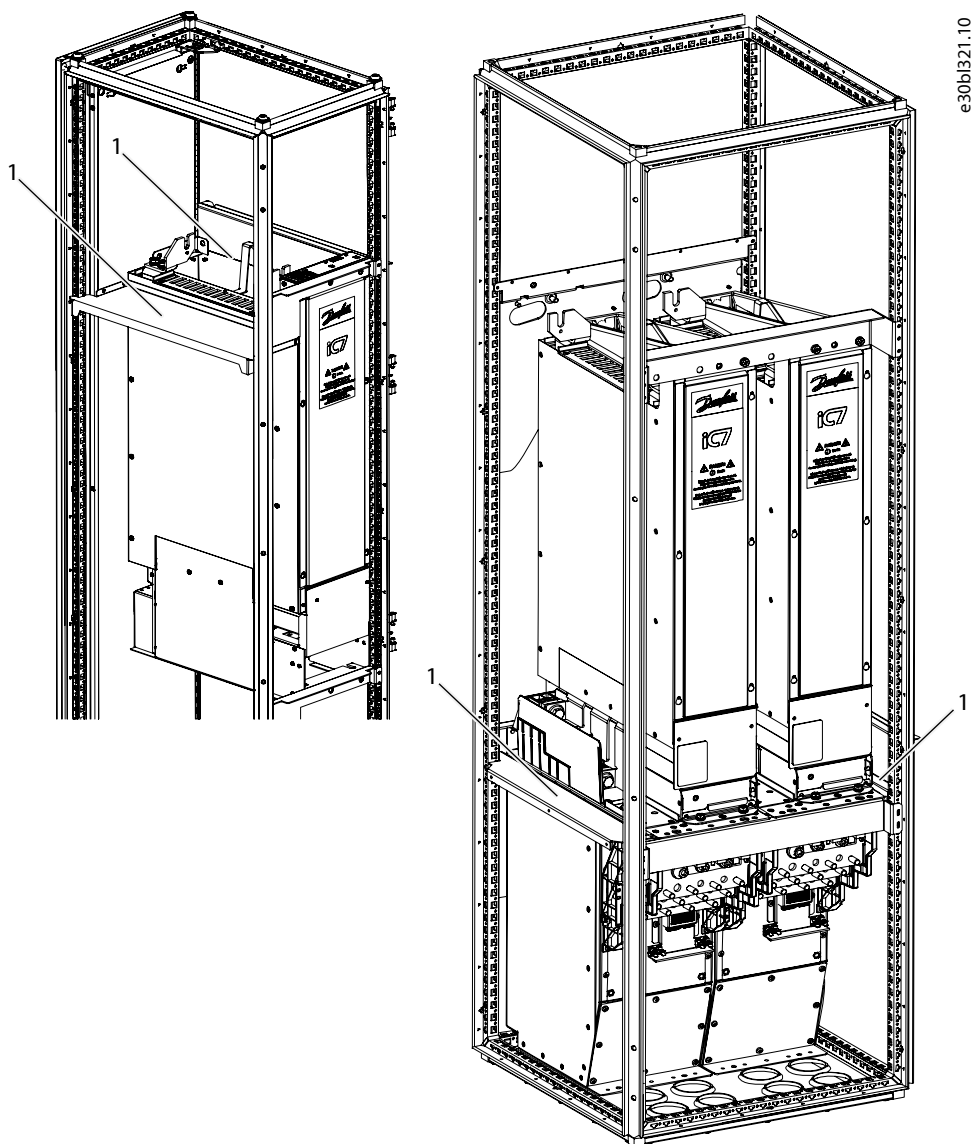

Figure 26: Air Guides of the IM10/IM11 (left) or IR10/IR11 (right) Modules in the Cabinet

1 Air guide

6 Electrical Installation Considerations

6.1 Cable Requirements

Follow these requirements for the mains and motor cables used in the drive system.

- Select and install mains cables and motor cables according to the local safety regulations, the input voltage, and the load current of the drive.
- Use motor cables rated for at least 70 °C (158 °F) surface temperature. If sufficient airflow at motor cable terminals in the cabinet cannot be ensured, use cables rated for 90 °C (194 °F). Consider the operating temperature of the mains terminals and make sure that the mains cables do not overheat near the input terminals.
- Use symmetrical power cabling with power units connected in parallel. Each power unit must have the same number of cables with an equal cross-section and equal length.

The maximum number of power unit cables and bolts sizes can be found in [10.4.1 General Cable Size Information](#).

Only use symmetrical and shielded 3-phase motor cables. See [Figure 27](#). Do not use symmetrical and shielded 3-phase cable with individual shield for each phase conductor or single-core phase conductors and PE with or without shield, see [Figure 28](#).

To reach C3 EMC performance, use shielded motor and mains cables and ensure 360° grounding of the motor and mains cable shield at both ends.

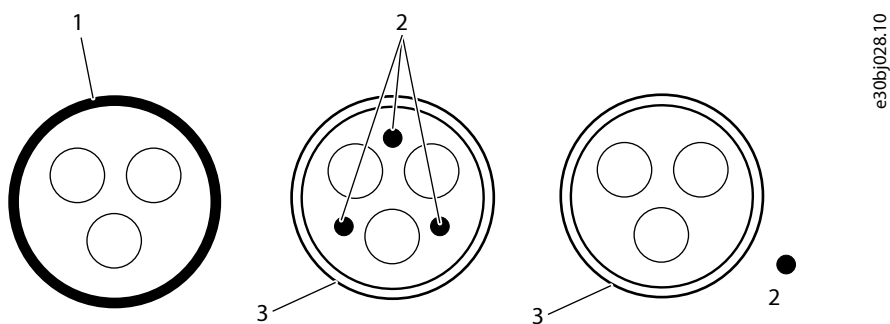

Figure 27: Recommended Cable Types for Mains and Motor Cabling

1	PE conductor and shield	2	PE conductor
3	Shield		

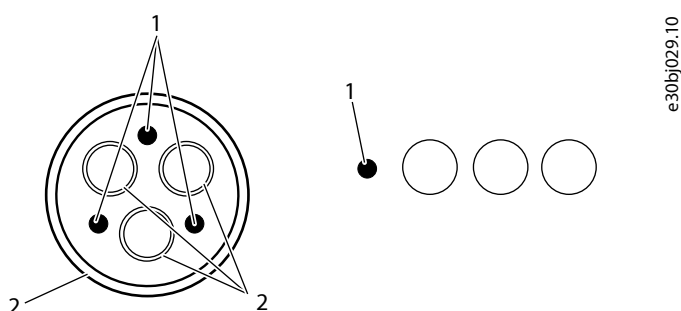

Figure 28: Not Recommended Motor Cable Types

1	PE conductor	2	Shield
---	--------------	---	--------

6.2 Grounding Principles

Ground the AC drive in accordance with applicable standards and directives.

According to IEC 60364-5-54; 543.1, unless local wiring regulations state otherwise, the cross-sectional area of the protective grounding conductor must be at least $\frac{1}{2}$ times of the phase conductor and made of the same material when the phase conductor cross-section is above 35 mm^2 (AWG 2).

The connection must be fixed.

6.3 Grounding the Products

1. Ground the products at the grounding spots.

See [10.1 Tightening Torques](#).

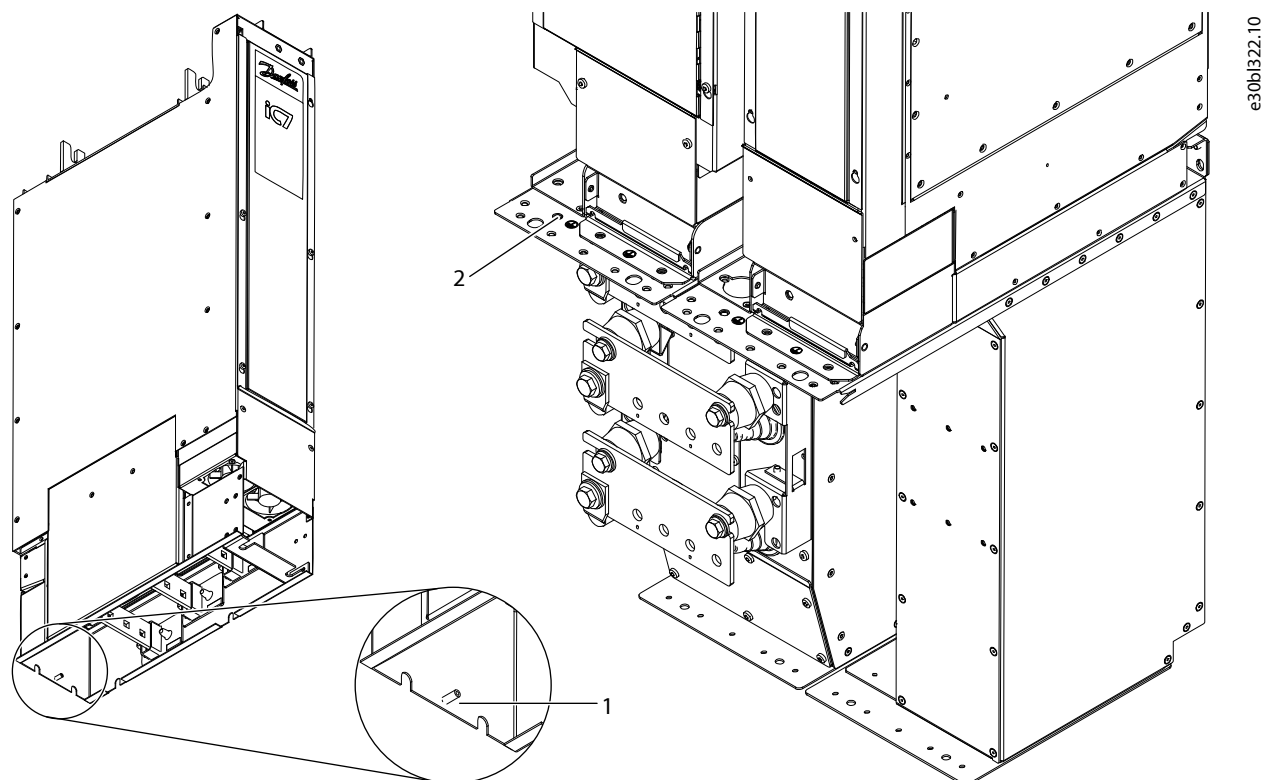

Figure 29: Grounding Stud of the Inverter Module and Grounding Terminal of the LCL Filter

1	Grounding stud	2	Grounding terminal
---	----------------	---	--------------------

6.4 Prerequisites for Cable Installation

Table 9: Minimum Distances from Motor Cables to Other Cables

Distance to other cables [m (ft)]	Length of the shielded motor cable [m (ft)]
0.3 (1.0)	≤ 50 (164)
1.0 (3.3)	≤ 150 (492)

1. Before starting, make sure that none of the components of the AC drive is live. Read all safety precautions in this guide and other documents available for this product.
2. Make sure that the motor cables are sufficiently far from other cables.
3. The motor cables must cross other cables at an angle of 90° .

4. If it is possible, do not put the motor cables in long parallel lines with other cables.
5. If the motor cables are in parallel with other cables, obey the minimum distances (see [Table 9](#)).
6. The distances are also valid between the motor cables and the signal cables of other systems.
7. The maximum length of shielded motor cables is 150 m (492 ft). If the used motor cables are longer, contact the vendor to get more information. The motor cable length is based on the maximum number of cables for each frame. For example, the 590 A inverter module is based on 3 parallel cables, and the 880 A inverter module on 4 parallel cables. The default motor cable operating capacitance is 0.75 nF/m. If some other cable type is used, or the number of cables connected in parallel does not match with recommendations, the maximum motor cable length must be derated so that the maximum total motor cable capacitance is not exceeded.
 - a. Default maximum motor cable setup for IM11: $4 \times (3 \times 120 + 70) \text{ mm}^2$, 150 m, 0.75 nF/m \rightarrow $CTOT = 4 \times 150 \text{ m} \times 0.75 \text{ nF/m} = 450 \text{ nF} = CMAX$
 - b. Example where the number of motor cables connected in parallel is higher than the default: $6 \times (3 \times 120 + 70) \text{ mm}^2$, 100 m, 0.75 nF/m \rightarrow $CTOT = 6 \times 100 \text{ m} \times 0.75 \text{ nF/m} = 450 \text{ nF} = CMAX$
 - c. Example where the motor cable capacitance is higher than the default: $4 \times (3 \times 120 + 70) \text{ mm}^2$, 130 m, 0.85 nF/m \rightarrow $CTOT = 4 \times 130 \text{ m} \times 0.85 \text{ nF/m} = 442 \text{ nF} < CMAX$
8. The maximum cable length of the filters is also 150 m (492 ft).
9. Only use symmetrical and shielded motor cables.
10. Use symmetrical power cabling with power units connected in parallel. Each power unit must have the same number of cables with an equal cross-section and equal length.
11. Perform the cable insulation checks if necessary.

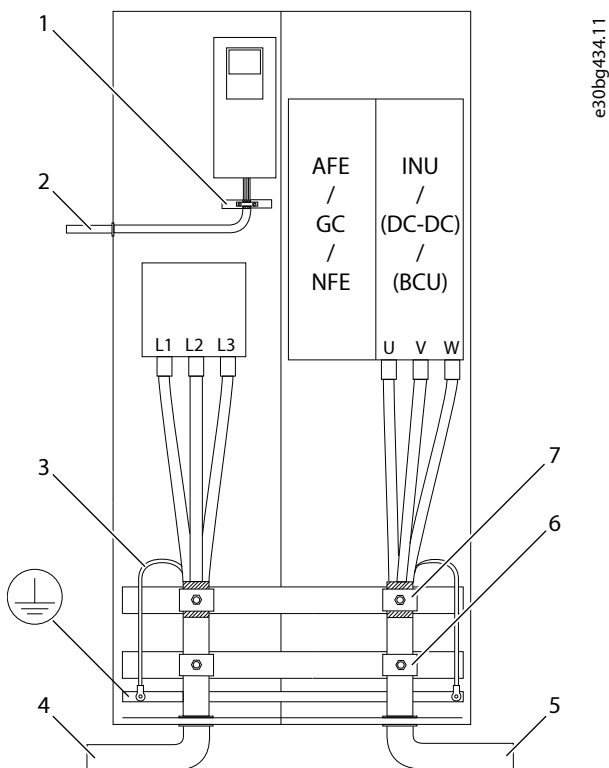

Figure 30: Cabling Principle

1	Grounding bar of the control cable	2	Control cable
3	Grounding conductor	4	Mains cables

- | | | | |
|---|-------------------------------------|---|---------------|
| 5 | Motor cables | 6 | Strain relief |
| 7 | The grounding clamp, 360° grounding | | |

6.5 Recommended Installation of Motor Cables

If the power units are connected in parallel without output filters or only with a common-mode filter, the recommended common coupling point of motor cables is at the motor terminals. It is also possible to use an alternative installation method where the common coupling point of the motor cables is near the drives. In this case, to avoid current imbalance, the installation must be symmetrical and the tolerance of cable length (impedance) to common coupling point is maximum 5%. If the cable connections are not symmetrical, use a dU/dt filter or a sine-wave filter.

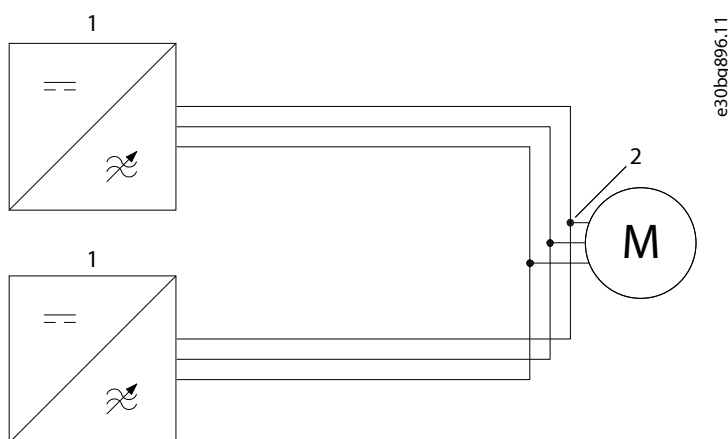

Figure 31: Recommended Installation

- | | | | |
|---|-----------------|---|--|
| 1 | Inverter module | 2 | Common coupling point at the motor terminals |
|---|-----------------|---|--|

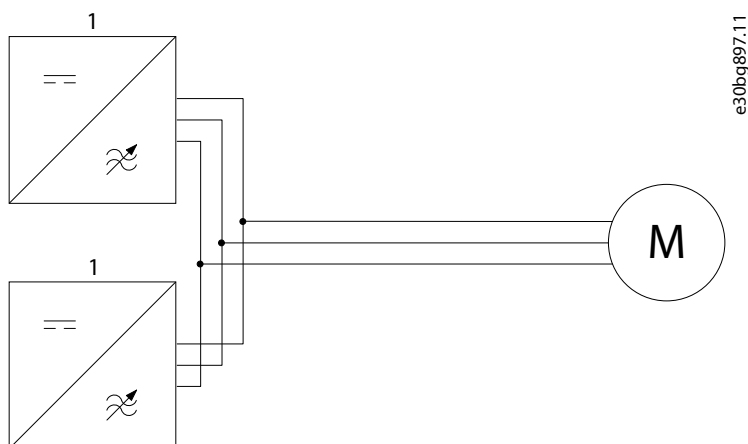

Figure 32: Alternative Installation Method

- | | |
|---|-----------------|
| 1 | Inverter module |
|---|-----------------|

6.6 Cable Requirements for the LCL Filter Fan Supply

NOTICE

The LCL Filter fan supply is protected with internal fuses. Use external fuses if the local safety regulations or installation conditions require fuse protection.

Table 10: DC-link Voltage Supply

Item	Value
Maximum load current	2 A
Maximum voltage	740 V DC

Table 11: Connector X121

Item	Value
Connector	Wago, 831-3103/037-000
Maximum wire insulation diameter	7 mm (0.3 in)
Wire stripping length	14 mm (0.6 in)
Conductor size	maximum 10 mm ² /AWG 8
Fine-stranded conductor	ferrule maximum 6 mm ²

Table 12: Cable Requirements

Area	Requirements	Example wire
IEC	Minimum 800 V DC voltage Minimum 2 A current	Leoni BETrans® 4 GKW-ENX R 1800 V M, 1x2.5 mm ² , order number 312474
UL	Minimum 600 V Minimum size AWG14 Minimum rated for 80 °C (176 °F)	UL AWM style 10269, AWG14

6.7 Connecting the LCL Filter Fan Supply

To enable the functioning of the LCL Filter fan, do these steps.

WARNING

The LCL Filter fan supply is protected with internal fuses. Use external fuses if the local safety regulations or installation conditions require fuse protection.

WARNING

SHOCK HAZARD FROM THE COMPONENTS

The components of the drive are live when the drive is connected to mains.

- Do not make changes in the AC drive when it is connected to mains.

1. Consider ambient temperature and other installation conditions.
2. Refer to the local safety regulations.
3. Protect the installation against mechanical and environmental damage and use strain relief when necessary.
4. Connect the DC-link voltage supply from the DC link to the LCL Filter connector X121.

Pay attention to the correct polarity.

Do not connect the supply between the AFE module and the DC fuses. The supply connection point is after the AFE module fuses.

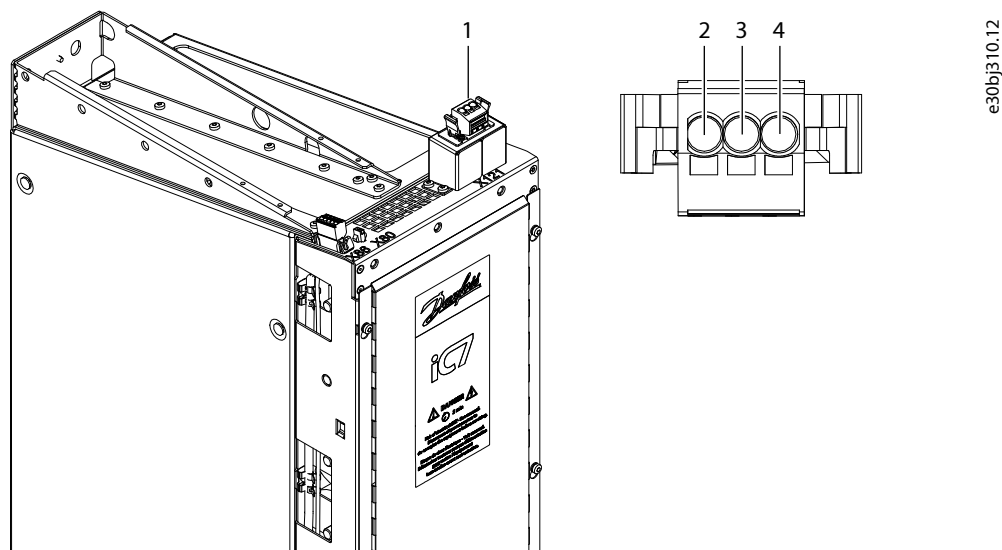

Figure 33: Fan Supply Connector of the LCL Filter

1	Fan supply (X121)	2	465–740 V DC (+)
3	Empty	4	0 V DC (-)

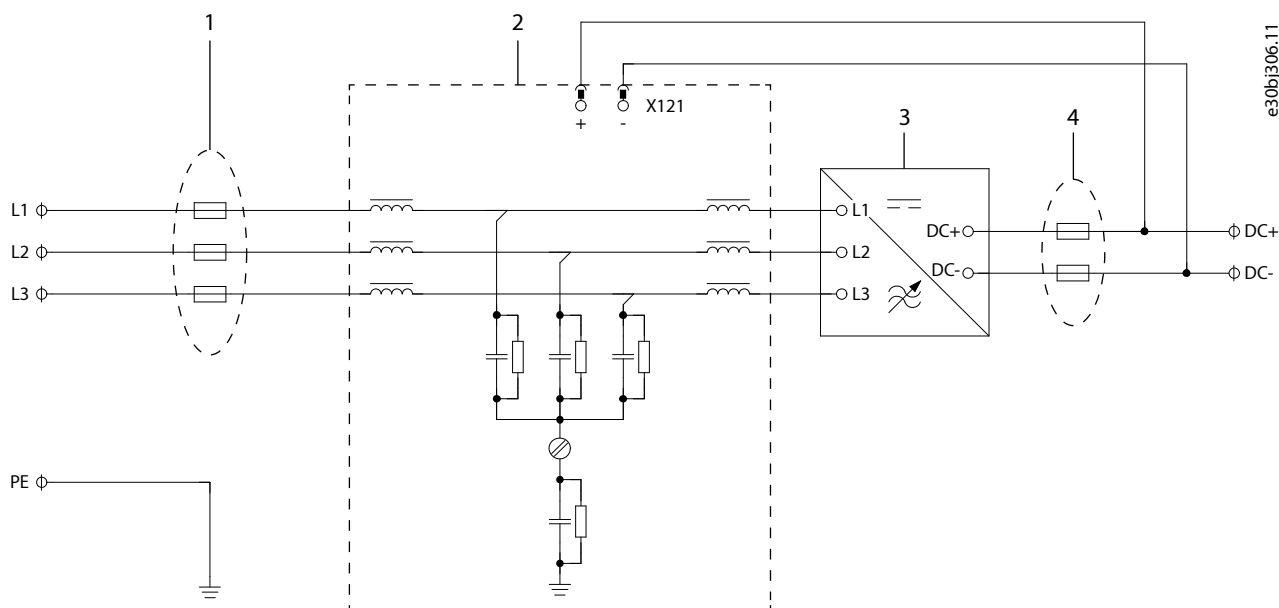

Figure 34: Diagram of the LCL Filter Fan Supply

1	AC fuses	2	LCL Filter
3	AFE module	4	DC fuses

6.8 Installation in an Impedance-grounded (IT) System

If the mains is impedance-grounded (IT), the AC drive must have the EMC protection level C4. If the drive has the EMC protection level C3, it is necessary to change it to C4. To change the EMC protection level of the AC drive from C3 to C4, disconnect the LCL Filter ground capacitor.

In a non-dedicated IT system, it is recommended to leave the ground capacitors connected in each AFE to limit conducted high-frequency disturbances between devices across the system. A non-dedicated IT system is defined here as a network where several separate DC links are fed from the same AC supply.

If the ground capacitors are connected, continuous operation during an IT ground fault is not allowed, because a large fault current is going through the capacitors.

In common DC bus installations, it is recommended to have ground capacitors on the DC bus side (DC+ to PE and DC- to PE) to balance the DC bus voltage against ground. In this case, the AC side ground capacitors should be disconnected.

In common DC bus installations with common-mode voltage sensitive energy storages or equipment, it is recommended to have ground capacitors on the DC bus side (DC+ to PE and DC- to PE) to balance the DC bus voltage against ground. In this case, the AC side ground capacitors should be disconnected. The ground capacitors should be sufficiently larger than the system parasitic capacitance to ground to be effective in limiting the common mode voltage peaks.

As a rule-of-thumb:

- 10 x system parasitic capacitance ~ 100 V common mode voltage to ground
- 100 x system parasitic capacitance ~ 10 V common mode voltage to ground

Continuous operation during ground fault when DC side ground capacitors are connected is not allowed due to potentially large fault currents.

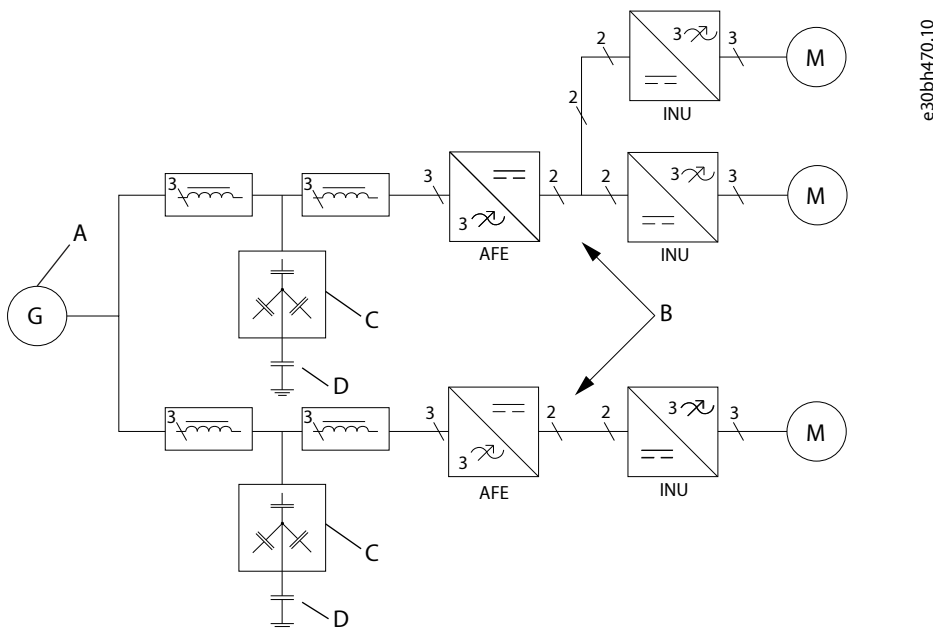
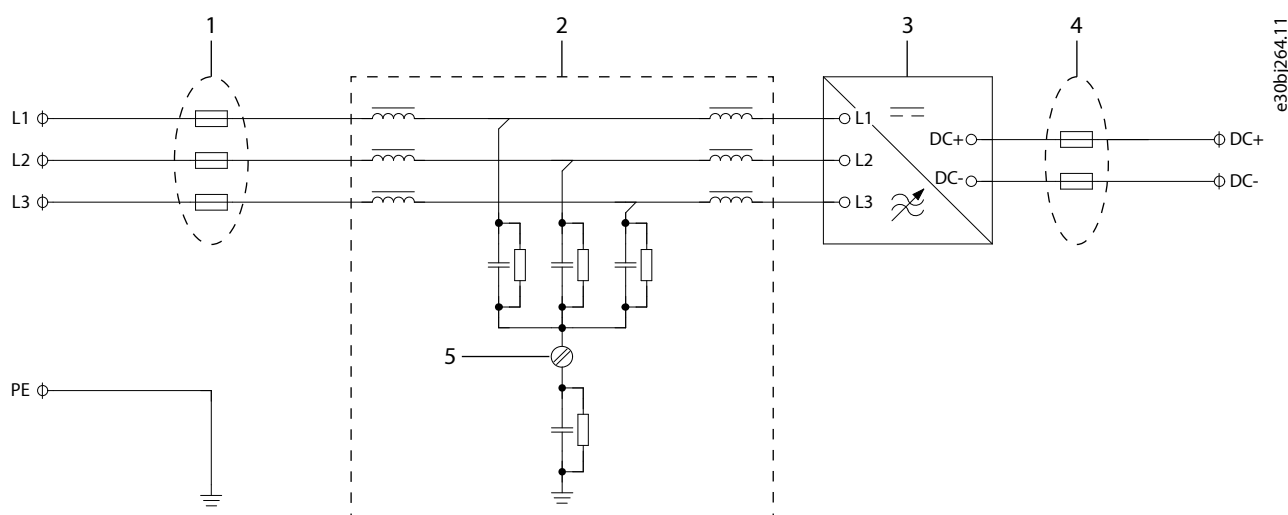

Figure 35: AFE Modules in IT System

A	AC grid, floating	B	Separate DC links
C	Filter capacitors	D	Ground capacitor/capacitors on the LCL Filter side



e30b|264.11

Figure 36: Diagram of the LCL Filter

1	AC fuses	2	LCL Filter
3	AFE module	4	DC fuses
5	The grounding wire		

6.9 Changing the EMC Protection Level in an IT System

In an IT system, to change the EMC protection level of the AC drive from C3 to C4, disconnect the LCL Filter ground capacitor.

NOTICE

DAMAGE TO THE AC DRIVE FROM INCORRECT EMC LEVEL

The EMC level requirements for the AC drive depend on the installation environment. An incorrect EMC level can damage the drive.

- Before connecting the AC drive to the mains, make sure that the EMC level of the AC drive is correct for the mains.

1. Loosen the screw of the grounding wire of the capacitor of the LCL Filter.
2. Remove the grounding wire from the phase capacitor.

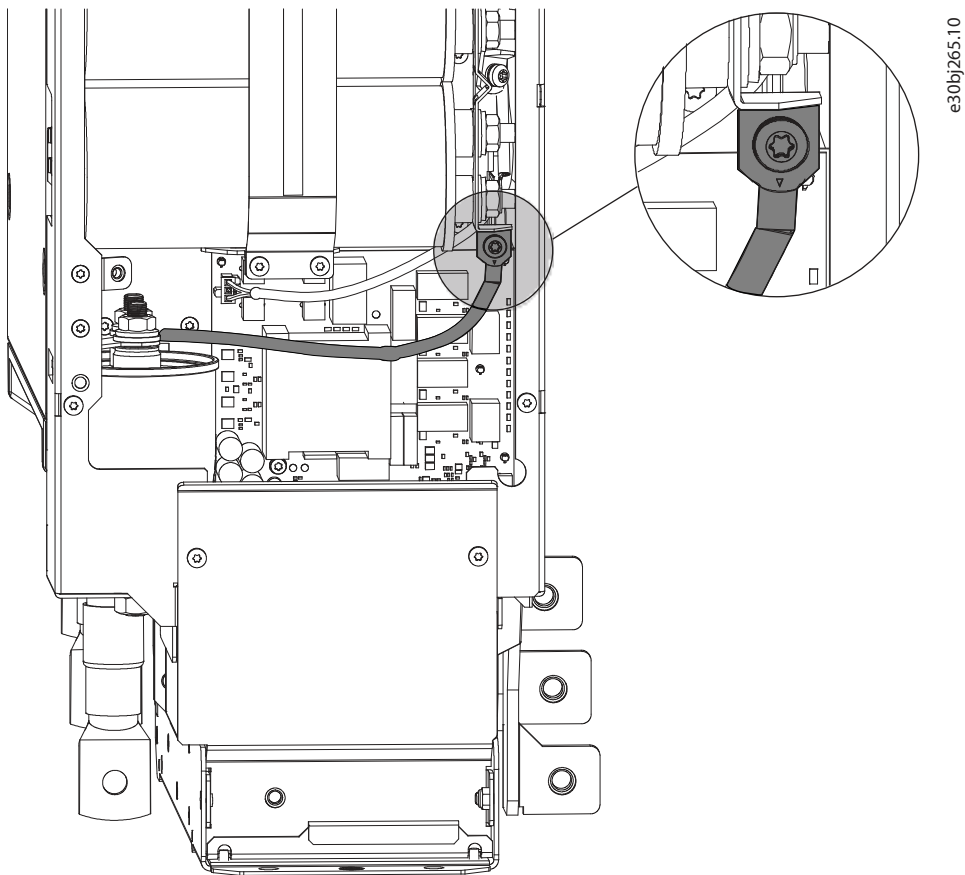

Figure 37: EMC Protection Level 3

3. Move the cable lug of the grounding wire with the screw onto the insulator and tighten the screw (maximum 0.5 Nm, 4.4 in-lb).

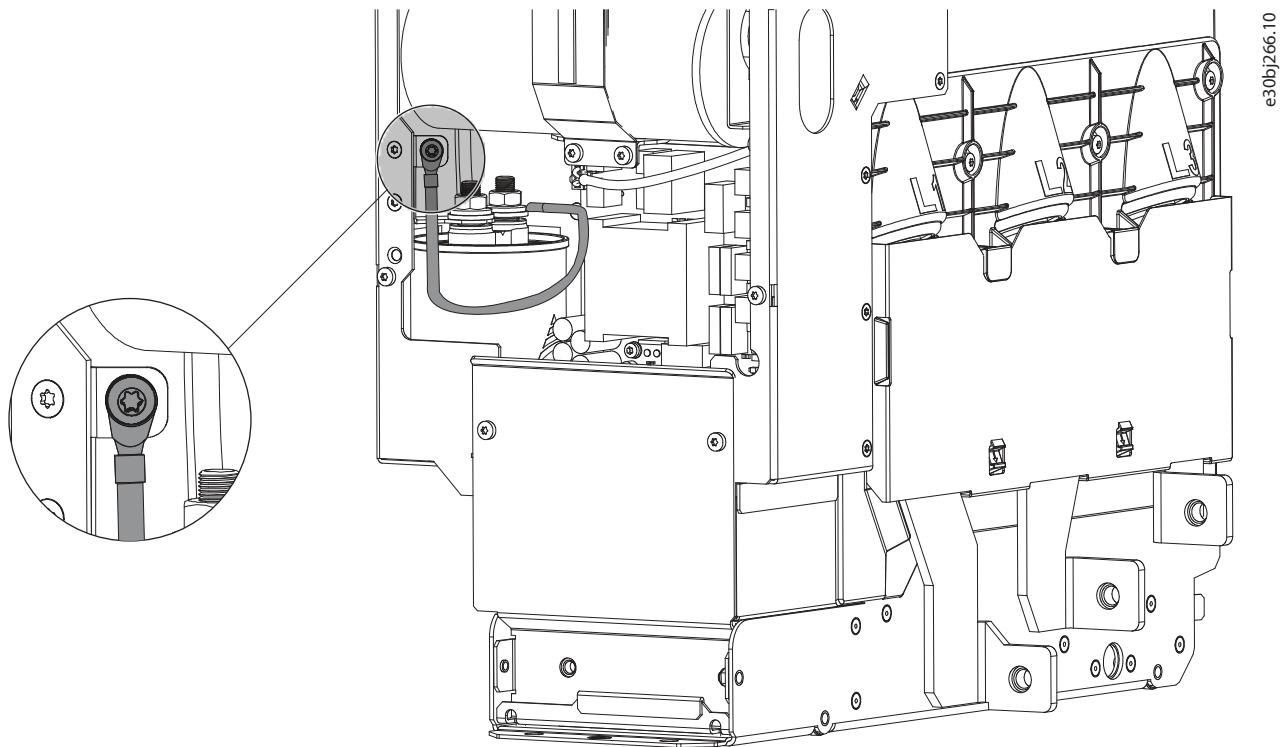

Figure 38: EMC Protection Level 4

- After the change, write "The EMC level was changed" and the date on the "product modified" label. If the label is not yet attached, attach it on the drive near the product label.

6.10 Fuses of the Drive System

The front-end modules in the drive system must be equipped with fast-acting AC fuses to limit the damage of the drive system. The fuse sizes are based on Mersen class aR fuses. Use these fuses to achieve sufficient protection against short circuits.

DC fuses must be installed in all system modules to limit the short-circuit current in fault situations. Each DC supply line must be equipped with fuses. The fuse sizes are based on Mersen class aR fuses. The DC fuses can be provided with the delivery as option. Do not replace the DC fuses with any other types.

The protective devices must be integrated within the same overall assembly as the system module. The fuse tables can be found in [10.5.1 List of Fuse Size Information](#).

Fuse ratings are based on a maximum fuse ambient temperature of 55 °C (131 °F) and at least 3 m/s airflow.

To ensure fuse performance, make sure that the available supply short-circuit current is sufficient. See minimum required values ($I_{cp,mi}$) at the fuse location in the tables of AC Fuses for AFE in [10.5.1 List of Fuse Size Information](#).

The AC fuses of the AFE module are delivered separately. See installation instructions in the *iC7 Series Air-cooled System Modules Installation Guide*.

6.11 Guidelines for DC Connections of System Modules

The DC busbars and cabling must be dimensioned according to local installation regulations and codes, so that the cross-section is sufficiently large for the current flowing at the relevant point. See the DC current ratings in [10.6.1 General Current Rating Information](#).

The DC busbar itself must be designed to attain the lowest possible inductance.

Adequate fuse protection for the drive configuration must be provided on the line side and on the DC side. The power cables and busbars must be dimensioned with sufficient thermal and mechanical strength to handle short circuits in the system. See the fuse ratings in [10.5.1 List of Fuse Size Information](#).

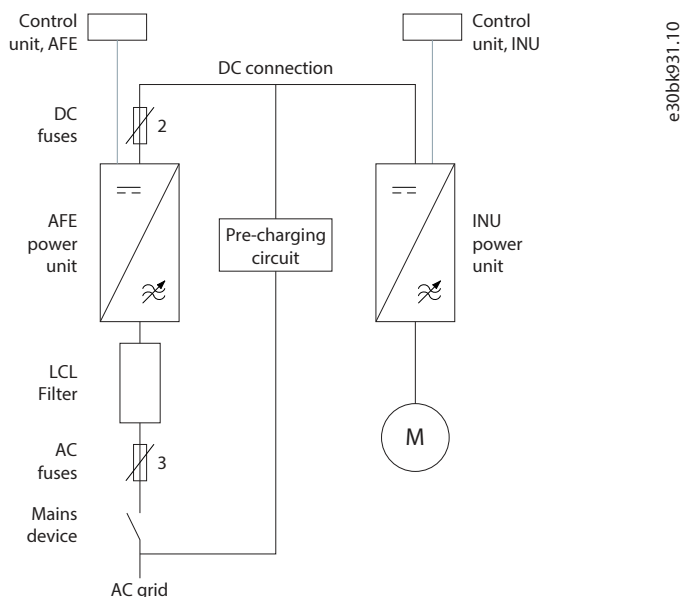

Figure 39: DC Connections of Single Power Units

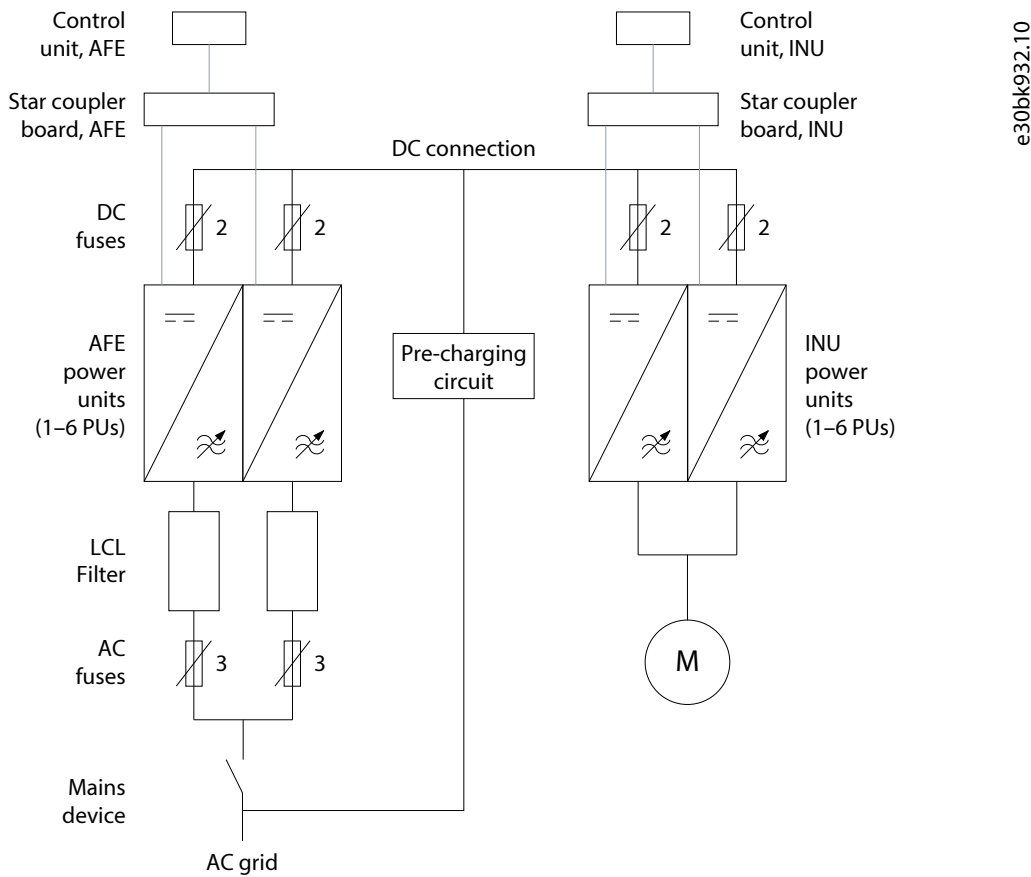

Figure 40: DC Connections of Parallel Power Units

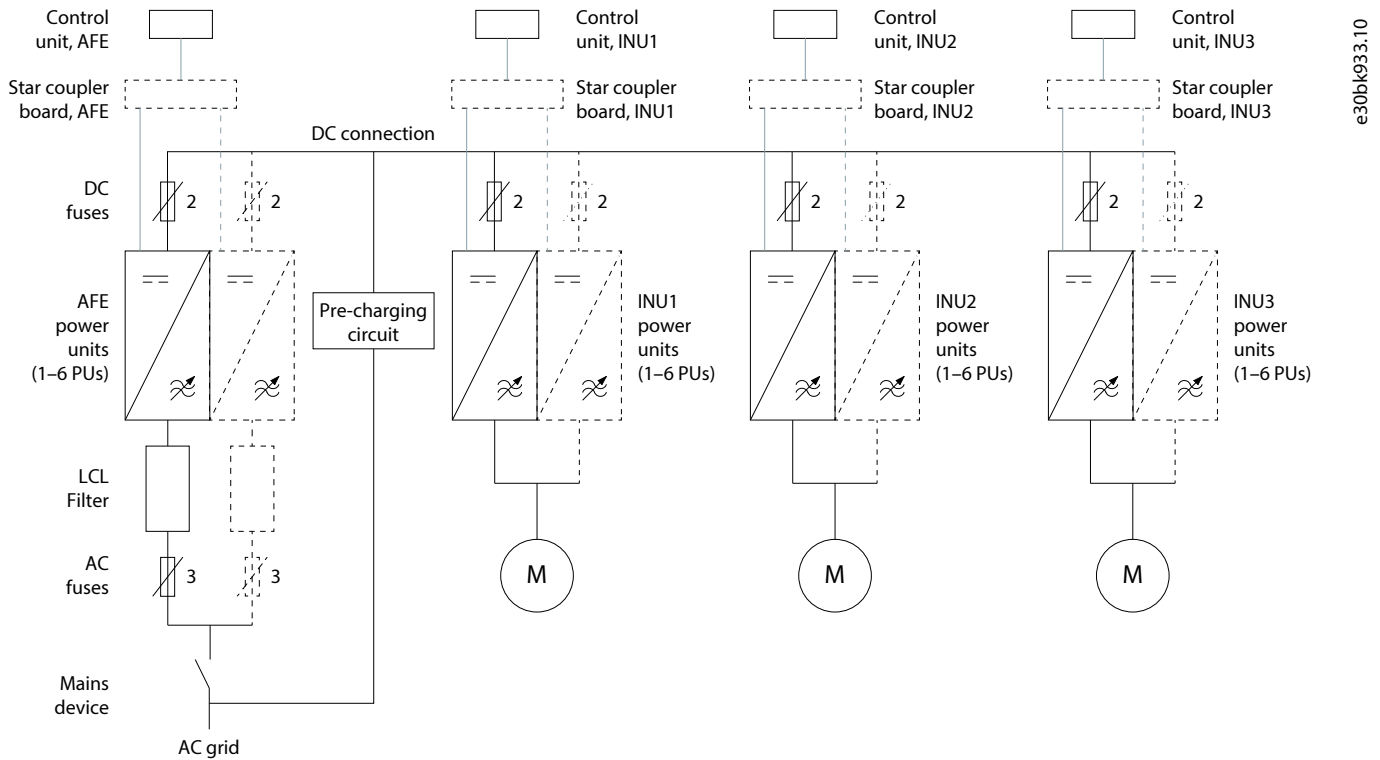

Figure 41: DC Connections of a Drive Lineup

6.12 Terminals of the System Modules

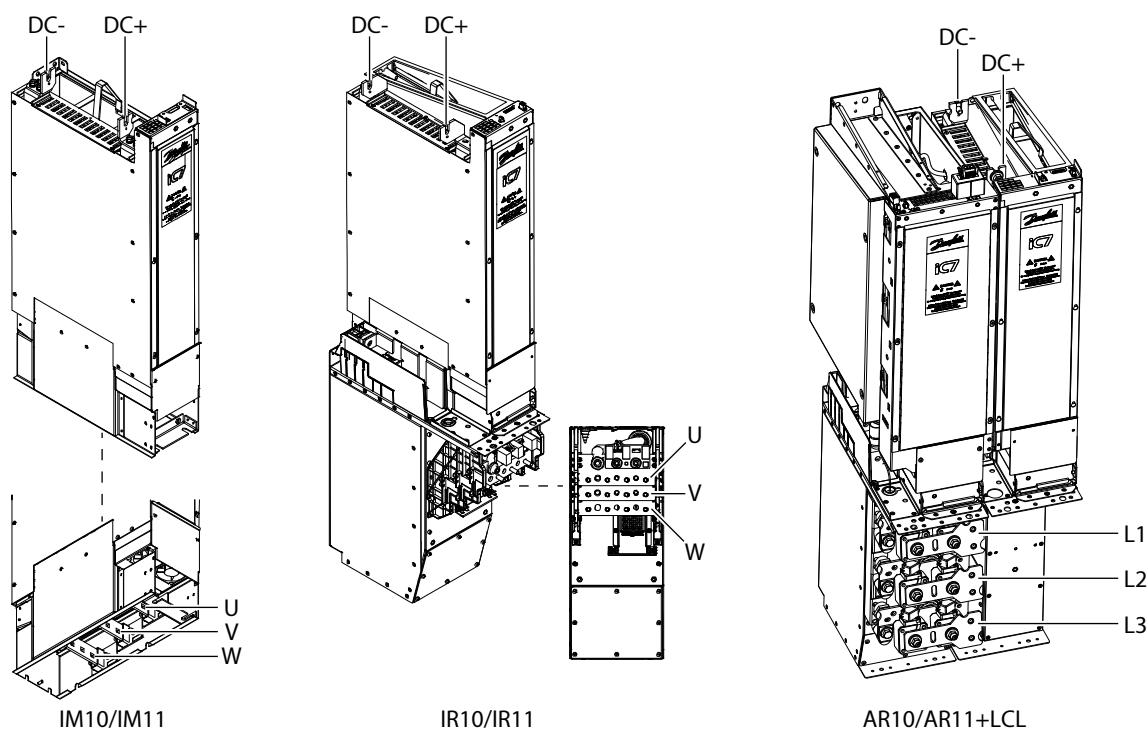

Figure 42: Locations of the Terminals on the System Modules

6.13 Auxiliary Power Connection of the Power Unit

The service 24 V DC supply terminal X80 for the power unit is used for service purposes together with the output terminal X67. When there is a 24 V DC power, it is possible to update the firmware, do commissioning checks, or check node communication.

For service and commissioning procedures, connect 24 V DC supply to both terminals X80 and X67. After the tasks are completed, disconnect the 24 V DC supply.

Connector type	Molex Mini-Fit Jr. Receptacle Housing, dual row, 2 circuits, part number: 39012025
Terminal type	Molex Mini-Fit Female Crimp Terminal, part number: 39000039 (bag)

During normal operation, the 24 V DC output terminal X67 provides power supply and AuxBus connectivity for the system module. The power supply is a GND referenced, +24 V DC $\pm 5\%$, 40 W supply which is also used for powering the AuxBus. The AuxBus topology and connection points are described in 6.16.2 AuxBus Cable Requirements. The power supply is recommended and designed for powering the control unit and options of the system module.

The recommended connector is 1769919/Phoenix contact. The correct tightening torque is 0.22–0.25 Nm (1.9–2.2 in-lb).

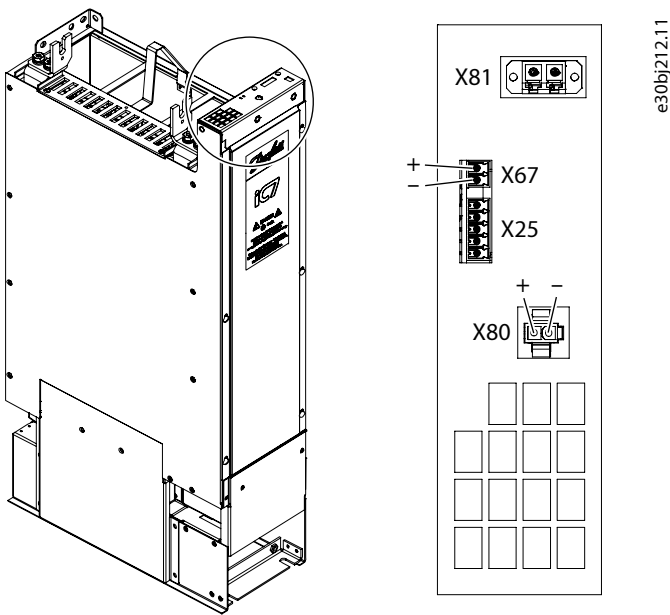

Figure 43: Auxiliary Connections of the Power Unit

X25	AuxBus terminal	X80	Service 24 V DC supply terminal
X81	Control terminal	X67	24 V DC output terminal

6.14 AuxBus Communication

6.14.1 Usage of AuxBus

AuxBus enables communication for the filters. When AuxBus is connected, the drive provides temperature monitoring and other diagnostics of the used options thus giving vital information about the system. AuxBus is also used to create warning and fault signals for the system.

The AuxBus network topology is a 2-wire CAN-based bus line terminated at both ends by resistors. The connection includes a feedback loop wire which disables automatic termination in the AuxBus board. The last AuxBus board automatically enables termination when feedback is not present. Additional termination resistors are not necessary.

NOTICE

For the drive to be able to protect the filters, AuxBus must be connected.

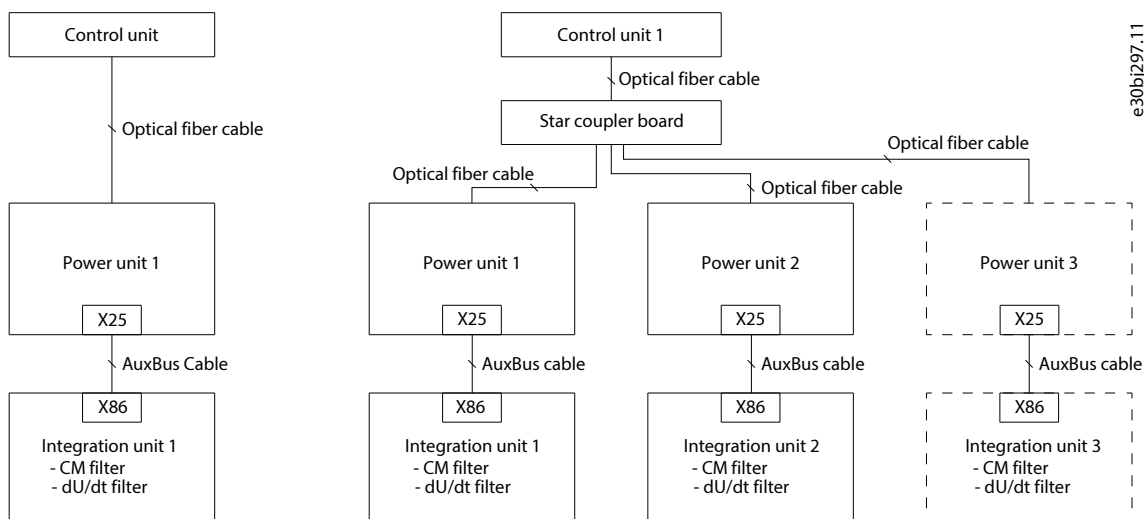

e30bj297.11

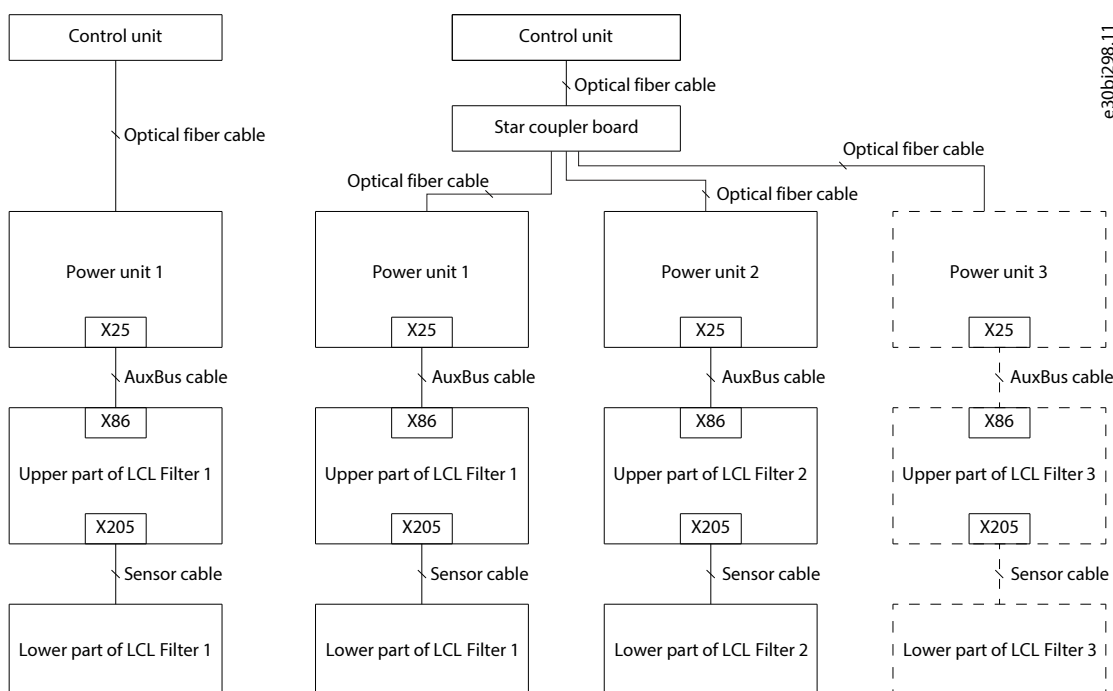
Figure 44: AuxBus Topology for Inverter Modules

e30bj298.11

Figure 45: AuxBus Topology for AFE Modules and LCL Filters

6.14.2 AuxBus Cable Requirements

It is recommended to use the AuxBus cables that are provided by Danfoss. AuxBus is delivered with 3 m (10 ft) of cable. If other cables are used, see the table [Table 13](#).

NOTICE

RISK OF ELECTRICAL INTERFERENCE

AuxBus consists of point-to-point connection, but the signals are connected in series. Cables that are longer than 10 m (33 ft) can create interference and communication problems.

- Do not exceed 10 m (33 ft) of total AuxBus cabling.
- Keep AuxBus cables as short as possible and separate them from high-power cables.

Table 13: Cable Requirements for Other than Danfoss-provided Cables

Item	Value
Cable type	6-wire, shielded and twisted pair (STP)
Impedance	120 Ω
Maximum length	10 m (33 ft)

Cable (example): LAPP KABEL, UNITRONIC® BUS LD FB P, 2170215.

Cable (example, UL): LAPP KABEL, UNITRONIC® BUS LD FB P A, 2170815.

Connector: Phoenix Contact, MC 1,5/ 5-ST-3,5 BK, 1769919 (LCL Filter: 2721-105/026-000).

Cabling recommendation for drives with a loose option AuxBus

Cabling recommendation for drives with integration unit filters

6.14.3 AuxBus Grounding Principles

To ensure robust communication, good grounding strategy is needed. Below is a recommended grounding strategy illustrated using integration units. Same strategy can be applied for loose option filters.

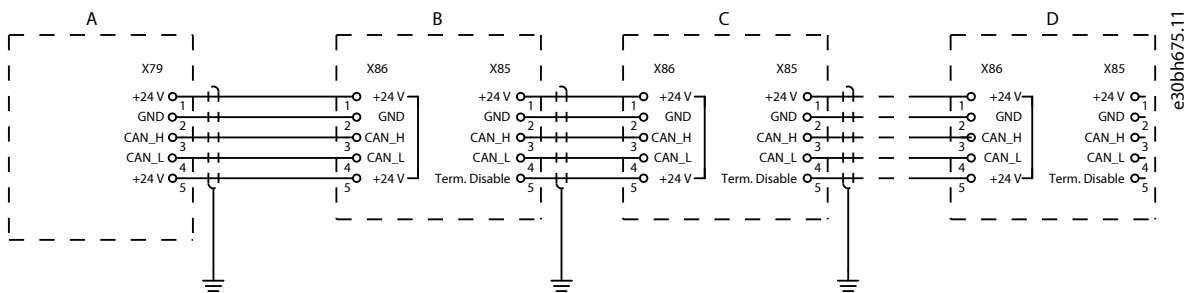

Figure 46: AuxBus Circuit Diagram

- | | | | |
|---|--|---|----------------|
| A | The AuxBus interface in the power unit | B | AuxBus board 1 |
| C | AuxBus board 2 | D | AuxBus board 3 |

6.14.4 AuxBus Terminals of the LCL Filter and the Integration Unit

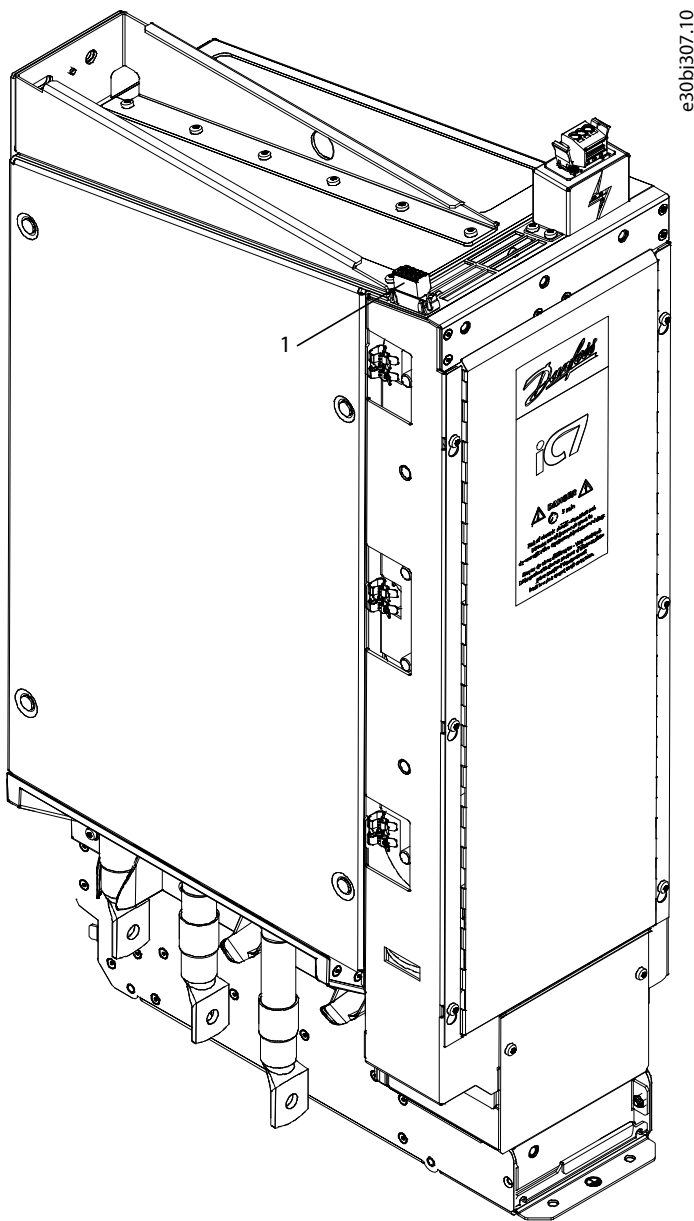

Figure 47: AuxBus Terminals of the LCL Filter

- 1 AuxBus in (X86)

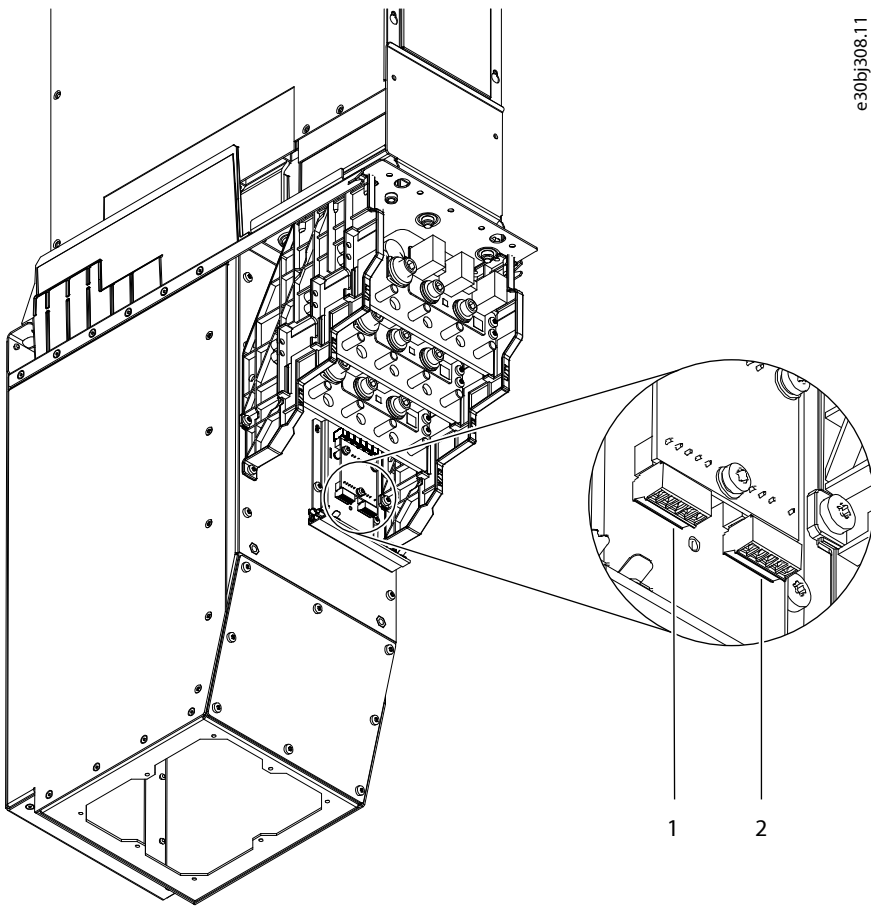

Figure 48: AuxBus Terminals of the Integration Unit

1	AuxBus out (X85)	2	AuxBus in (X86)
---	------------------	---	-----------------

7 Options and Accessories for the Air-cooled System Modules

7.1 dU/dt Filter

With the dU/dt Filter, the nominal switching frequency is 3 kHz DPWM. The maximum switching frequency is 6 kHz DPWM.

The dU/dt Filter can be used without derating up to 70 Hz. For output frequencies higher than 70 Hz, current must be derated according to the curve shown in [Figure 49](#). Above 120 Hz, a special high-speed filter is recommended.

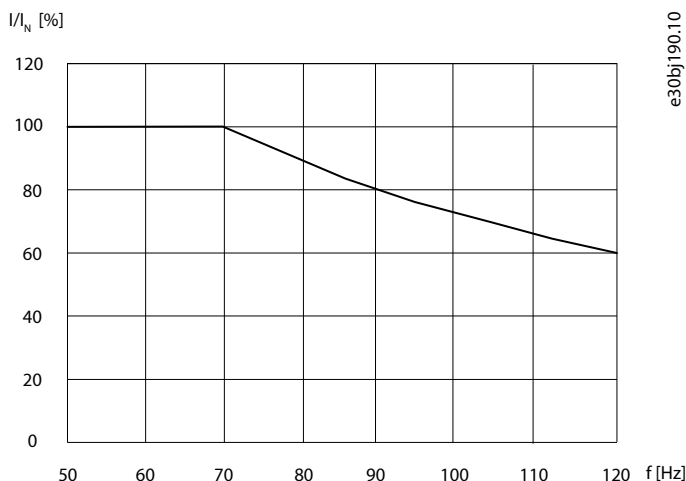

Figure 49: Output Frequency Derating

Maximum motor cable length depends mainly on switching frequency, DC-link voltage, and motor cable setup. In nominal conditions, the maximum motor cable length is 150 m (492 ft). The motor cable length is based on the maximum number of cables for each frame. For example, the limits for a 590 A filter are based on 3 parallel cables, and for an 880 A filter on 4 parallel cables. The default motor cable operating capacitance is 0.75 nF/m. If another cable type is used, or the number of cables connected in parallel does not match the recommendations, the maximum motor cable length must be derated so that the maximum total motor cable capacitance is not exceeded.

Losses are higher in low output frequency range (0–5 Hz). If drives are operating in this range, the maximum motor cable length (capacitance) must be derated 10%.

7.2 Common-mode Filter

With the Common-mode Filter, the nominal switching frequency is 3 kHz DPWM. The maximum switching frequency is 6 kHz DPWM. The Common-mode Filter can operate in the whole output frequency range of the drive.

The maximum motor cable length depends mainly on switching frequency, DC-link voltage, and motor cable setup. In nominal conditions, the maximum motor cable length is 150 m (492 ft). The motor cable length is based on the maximum number of cables for each frame. For example, the limits for a 590 A filter are based on 3 parallel cables, and for an 880 A filter on 4 parallel cables. The default motor cable operating capacitance is 0.75 nF/m. If another cable type is used, or the number of cables connected in parallel does not match the recommendations, the maximum motor cable length must be derated so that the maximum total motor cable capacitance is not exceeded.

Losses are higher in low output frequency range (0–5 Hz). If drives are operating in this range, the maximum motor cable length (capacitance) must be derated 20%.

In an IT system, filter losses in a single phase ground fault depend on the setup. All capacitances to ground should be minimized to minimize the fault current. The fault current increases the losses, and continuous operation during the ground fault cannot be guaranteed, especially if the filter is already in the limits without the fault. The filter has temperature protection against too high ground fault currents.

If drives are connected in parallel, the recommended common connection point for motor cables is at the motor terminals. See [6.5 Recommended Installation of Motor Cables](#).

7.3 LCL Filter

The LCL Filter is used with the AFE module, and it ensures correct power quality and minimal interruption to the grid. Each AFE power unit has its own LCL Filter. The LCL Filter is designed for the nominal AFE switching frequency. It is safe to increase the switching frequency, but decreasing the switching frequency below the nominal value increases the risk of overheating and unwanted resonances. An increased switching frequency leads to derating of the AFE module. See [10.7 Derating the Output Current](#).

There are 3 electrical sizes of the filter: LCL10 (514 A), LCL11 (816 A), and LCL11W (820 A).

NOTICE

Use aR-type AC fuses with the LCL Filter. Select the fuses according to the frame and the current rating of the system module. When designing the fuse installation, refer to the wiring diagrams of the AFE modules.

7.4 The Pre-charging Unit

The pre-charging unit is used for the pre-charging of the system modules that are connected to the same DC bus. There are 3 electrical sizes and an IEC and an UL variant of these. The pre-charging unit is available as an accessory.

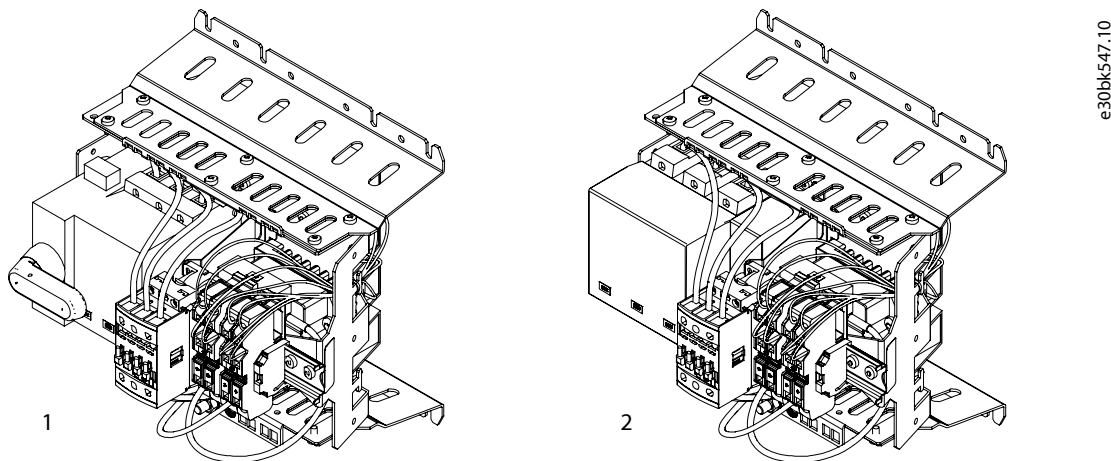

Figure 50: Pre-charging Units

1	Pre-charging unit, IEC
2	Pre-charging unit, UL

Table 14: Selection of the Correct Pre-charging Unit

System modules	Pre-charging unit
IM10 + IM10 / IR10 + IR10	Pre-charging unit 10 (IEC or UL)
IM11 + IM11 / IR11 + IR11	
2 x IM10 + 2 x IM10 / 2 x R10 + 2 x IR10	
2 x IM11 + 2 x IM11 / 2 x IR11 + 2 x IR11	Pre-charging unit 20 (IEC or UL)
3 x IM11 + 3 x IM11 / 3 x IR11 + 3 x IR11	
4 x IM11 + 4 x IM11 / 4 x IR11 + 4 x IR11	
5 x IM11 + 5 x IM11 / 5 x IR11 + 5 x IR11	Pre-charging unit 30 (IEC or UL)
6 x IM11 + 6 x IM11 / 6 x IR11 + 6 x IR11	

Table 15: Maximum Capacitance of the Pre-charging Unit

Pre-charging unit	Network [V AC]	Capacitance [μ F]
Pre-charging unit 10 (IEC or UL)	400/500	66500
	690	29500
Pre-charging unit 20 (IEC or UL)	400/500	184000
	690	76500
Pre-charging unit 30 (IEC or UL)	400/500	275000
	690	114500

There are thermal restrictions in a repeated use of the pre-charging unit. See the allowed pre-charging cycle in a 60 °C (140 °F) ambient temperature in [Table 16](#).

Table 16: The Thermally Allowed Pre-charging Cycle

Step	Task	Duration
1.	Charging	10 s
2.	Discharging	50 s
3.	Charging	10 s
4.	Discharging	50 s
5.	Wait for the pre-charging unit to cool down.	10 minutes
6.	Repeat	–

8 Control Unit

8.1 Modular Control Unit

The maximum input power of the internal 24 V DC power supply is 60 W.

NOTICE

EXTERNAL 24 V DC POWER SUPPLY OPTIONAL

- The power units of the air-cooled system modules provide a 24 V DC power supply for the control unit. But it is also possible to provide an external 24 V DC +15%/-10% power supply for the control unit.

NOTICE

CABLE INSULATION

- Insulation between 2 circuits must be designed according to the circuit that has the highest voltage.

NOTICE

SEPARATE 24 V WIRES FROM 115/240 V CABLES

The 24 V wires must be separated from the 115 V/240 V cables. If they are not separated, all wirings must be made with shielded 115 V/240 V cables.

NOTICE

SIGNAL CABLES

- It is recommended to use shielded/twisted pair signal cables.

Table 17: Maximum Power Consumption of the Control Unit Components

Component	Power consumption [W]
Control unit, including control panel	6
Star coupler board	4
I/O and Relay Option, 250 mA at 24 V _{out}	8
Any other option board, 1 pcs	4

The system modules are controlled with the modular control unit. The control unit and the system modules are connected via fiber optics. When 2 or more parallel system modules are used, a star coupler board is needed. The modular control unit provides an interface towards the customer's upper control system. The control unit includes 2 Ethernet ports for a fieldbus connection. Daisy chaining the fieldbus is supported for typical protocols, such as Modbus TCP and PROFINET RT. Additional functional extensions can be added to incorporate analog and digital inputs and outputs as well as other functionality such as temperature measurement or voltage measurement. A control panel is available for local control.

The modular control unit can be mounted nearby to or remotely from the power unit. The control unit consists of various boards installed on a mounting plate. The boards are connected to each other with option connectors. Several boards and mounting plates can be installed in parallel.

There are 3 different mechanical board types in the modular control unit:

- Control board
- Star coupler board

- Functional extensions, for example:
 - I/O and Relay Option OC7C1
 - Encoder/Resolver Option OC7M0
 - Temperature measurement option
 - Voltage measurement option

See more information on the option boards in the relevant installation guides and operating guides.

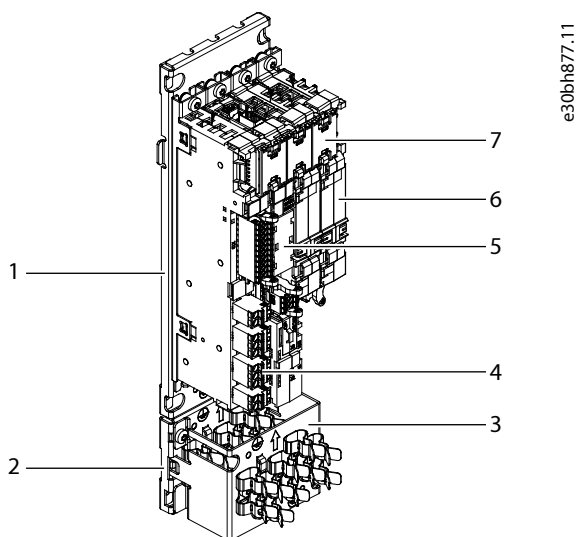

Figure 51: Example of the Modular Control Unit

1	Mounting plate	2	Base grounding plate
3	Grounding plate extension	4	I/O and Relay Option
5	Control board	6	Option board
7	Option connector		

8.2 Control Board

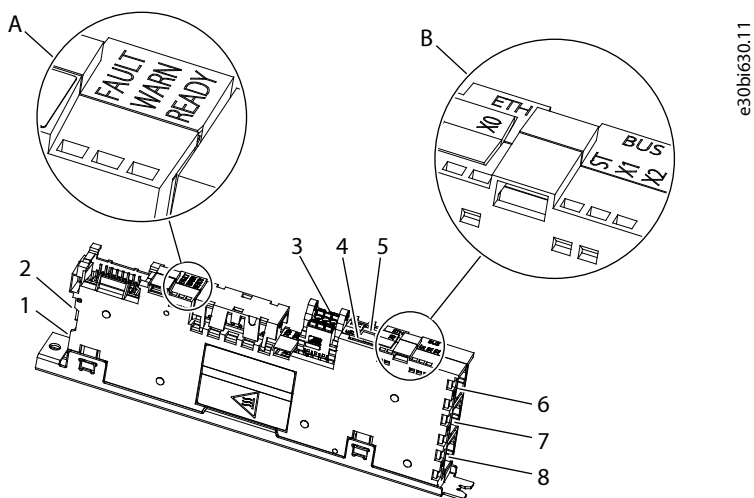

Figure 52: The Control Board

A	Status indicators (FAULT, WARN, READY)	B	Fieldbus indicators (ST, X1, X2) and Ethernet port indicators (X0)
1	Control panel connector (X9)	2	Fiber optic link to power unit (X80)
3	24 V DC supply (X62)	4	microSD card
5	RTC battery holder	6	Ethernet port (X0)
7	Ethernet port (X1)	8	Ethernet port (X2)

8.3 Definitions of the Indicator Lights on the Control Board

Table 18: Definitions of the Indicator Lights on the Control Board

Indicator name	Function (color)	Description
Fault	On (red)	Fault active
Warn	On (yellow)	Warning active
Ready	On (white)	Ready for operation
	Blinking 1 Hz (white)	Power on, not ready
Fault+Warn+Ready	Blinking (red + yellow + white)	Winking from an external application. Can be used for identifying where the external application is wirelessly connected to.
X0 link activity	Off	No link
	On (green)	Link OK, no data
	Blinking (green)	Link OK, data communication
X0 link speed	Off	No link or 10 Mbps link
	On (orange)	100 Mbps link

For the description of the fieldbus indicators (ST, X1, X2), see the relevant application guide.

8.4 Control Board Connections

Table 19: Control Board Connections

Terminal	Function	Connector type
X1	Ethernet port (used for fieldbus)	RJ45
X2	Ethernet port (used for fieldbus)	RJ45
X0	Ethernet port (used for the PC tool)	RJ45
Micro SD	microSD card	Micro SD
X62	24 V DC supply	2 x 3 spring force connector 0.2–1.5 mm ²
X33 for inverter module	STO terminal	1 x 10 spring force connector 0.2–1.5 mm ²
Option bus	Option bus (internal connection)	Custom
X80	Fiber optic link to power unit or star coupler board	LC-duplex
X9	Control panel terminal	iX Industrial
RTC battery	RTC battery	BR1632 (battery type)

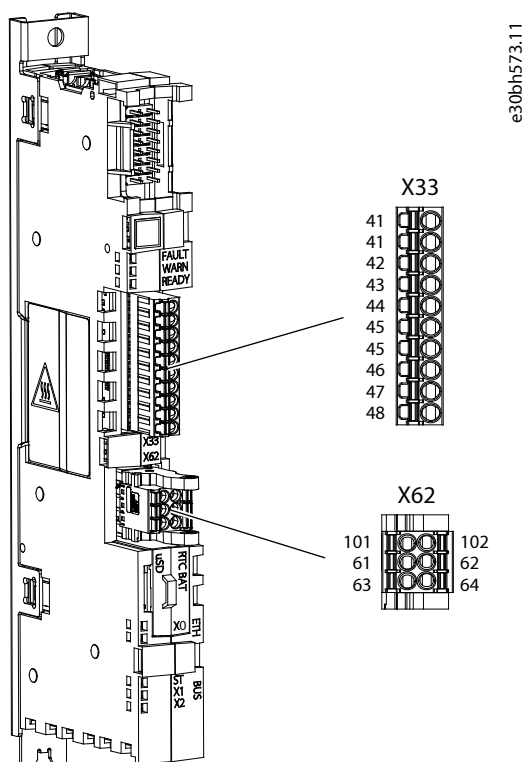

Figure 53: Control Board Terminal Block and Terminal Numbering

Table 20: STO Terminal Signals (X33) for the Inverter Module

Terminal	Function	Description
41A ⁽¹⁾	24 V	+ 24 V DC Output
41B ⁽¹⁾	24 V	+ 24 V DC Output
42	S.INA+	+ Safe Input Channel A
43	S.INB+	+ Safe Input Channel B
44	S.FB+	+ STO Feedback
45A ⁽¹⁾	GND	0 V/GND
45B ⁽¹⁾	GND	0 V/GND
46	S.INA-	- Safe Input Channel A
47	S.INB-	- Safe Input Channel B
48	S.FB-	- STO Feedback

1) Terminals 41A, 41B, 45A, and 45B have double pins to make connections easier.

Table 21: 24 V DC Supply Signals (X62)

Terminal	Function	Description
101	+24 V input	Internal +24 V DC, 60 W control supply
102	GND	Power supply ground
61	+24 V external input	External +24 V DC control supply, maximum 10 A. Must be fuse-protected. Possible to daisy chain for multiple controllers.

Table 21: 24 V DC Supply Signals (X62) (continued)

Terminal	Function	Description
62	GND	Power supply ground
63	+24 V output	+24 V DC output for daisy chain, only available when the +24 V DC external input control supply is used.
64	GND	Power supply ground

For the circuit diagrams of the control unit, see [10.3.8 Wiring Diagrams of the +24 V Supply for the Control Unit](#).

8.5 Star Coupler Board

System modules for high current ratings consist of multiple power units that are connected via a star coupler board to 1 control unit.

With the star coupler board, it is possible to connect 6 power units in parallel at the moment.

It is recommended to use an external 24 V power supply connected to the top of the star coupler board. The 24 V supply from the control board is supervised, so it is cut if consumption is exceeded due to external short circuits. The fiber connection is always needed between the control board and star coupler board.

The star coupler board can be installed next to the control unit. The star coupler board can also be installed near the power units to make the cabling from the star coupler board to the power units easier. See [Figure 57](#).

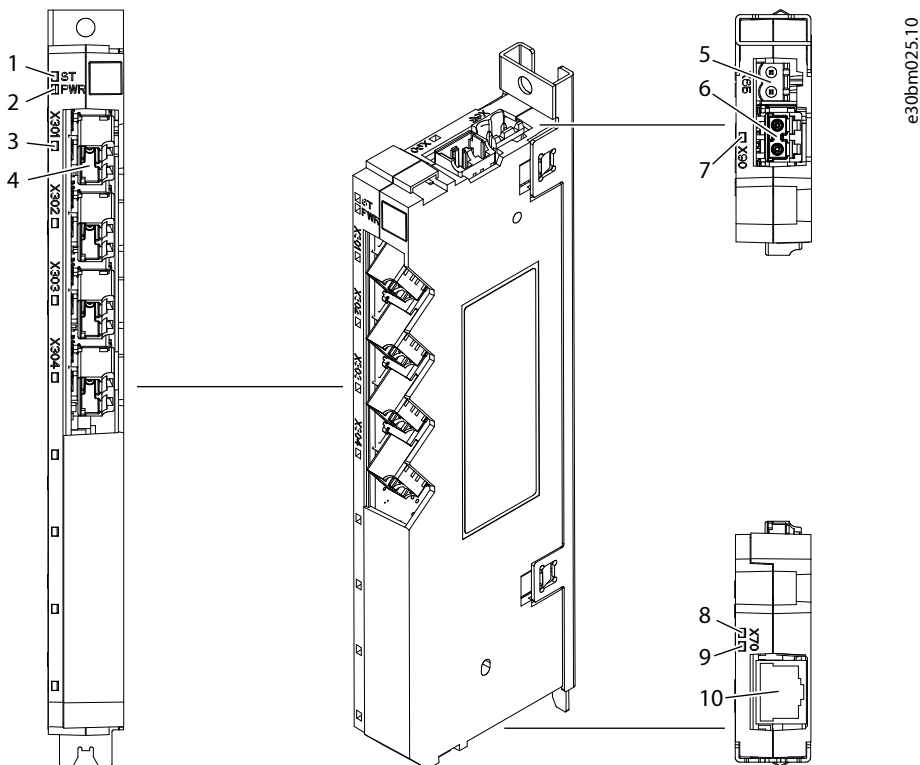

Figure 54: Terminal and Indicator Light Locations on the 4-port Star Coupler Board

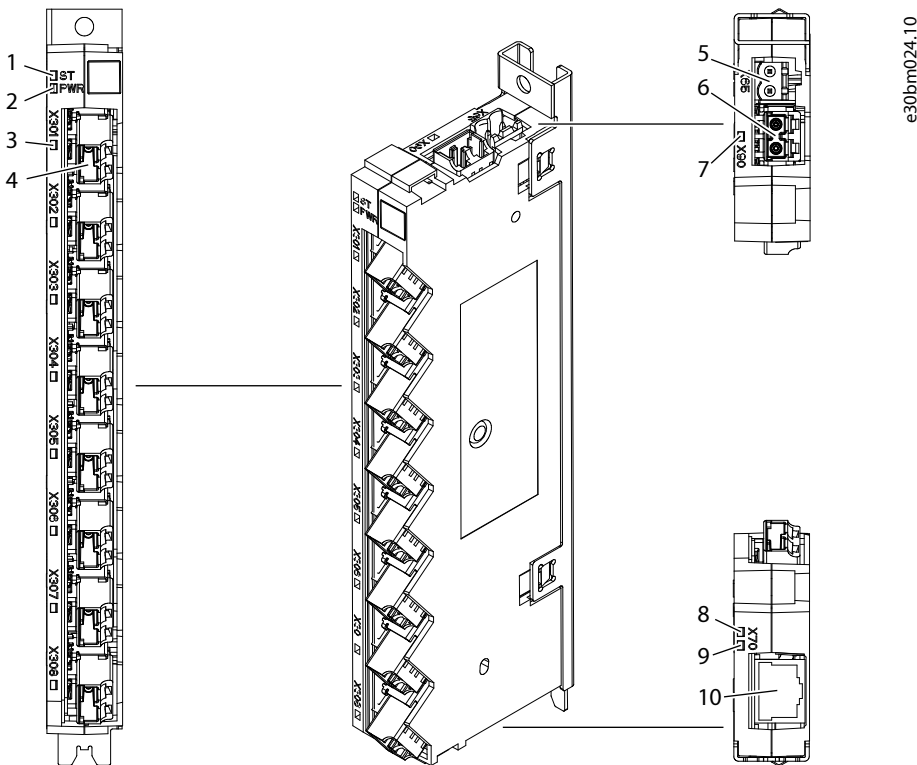

Figure 55: Terminal and Indicator Light Locations on the 8-port Star Coupler Board

1	Board configuration status indicator	2	+24 V power status indicator
3	Power unit connection status indicators	4	Fiber connection to the power unit (X301–X316)
5	+24 V power supply (X65)	6	Fiber connection to the control board (X90)
7	Control link status indicator	8	Ethernet speed indicator
9	Ethernet link activity indicator	10	Ethernet port (X7)

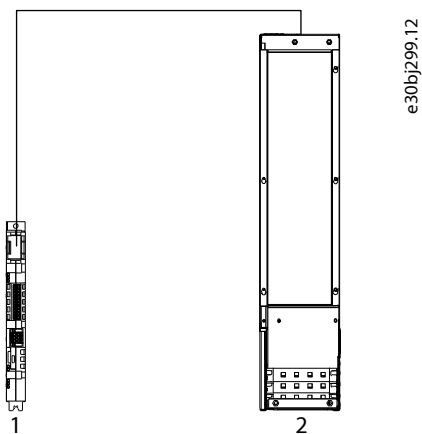

Figure 56: Control Connection

1	Control board	2	Power unit
---	---------------	---	------------

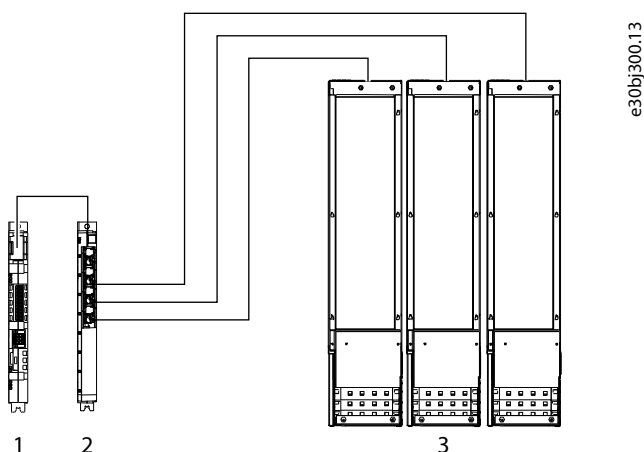

Figure 57: Example Control Connection with a Star Coupler Board: 3 Power Units in Parallel

1	Control board	2	Star coupler board
3	3 power units		

8.6 Definitions of the Indicator Lights on the Star Coupler Board

Table 22: Definitions of the Indicator Lights on the Star Coupler Board

Indicator name	Function (color)	Description
Configuration status	Off	During booting, until the software configuration is executed.
	Blinking 10 Hz (green)	Software updating.
	On (green)	Board configuration succeeded and all port communication works as intended.
	On (red)	Board configuration failed or any port communication failed on startup or during run.
24 V power status	On (white)	Star coupler board is powered. ⁽¹⁾
Power unit link status (X301–X316)	Off	No link established.
	On (green)	Link established.
Control link status	Off	No link established.
	On (green)	Link established.
Ethernet speed	Off	No link or 10 Mbps link
	On (orange)	100 Mbps link
Ethernet link activity	Off	No link
	On (green)	Link OK, no data
	Blinking (green)	Link OK, data communication

1) If there is no software on the star coupler board or the software cannot be executed, the indicator light does not turn on.

8.7 Star Coupler Board Connections

Table 23: Star Coupler Board Connections

Terminal	Function	Connector type
X7	Ethernet port	RJ45
X65	24 V DC supply	2 x spring force connector 2.5 mm ²
X90	Fiber optic link to control board	LC-duplex
X301–X316	Fiber optic link to power unit	LC-duplex

Table 24: 24 V DC Supply Signals (X65)

Terminal	Function	Description
61	+24 V external input	External +24 V DC star coupler supply, maximum 10 A. Must be fuse-protected.
62	GND	Power supply ground

8.8 I/O and Relay Option Connections

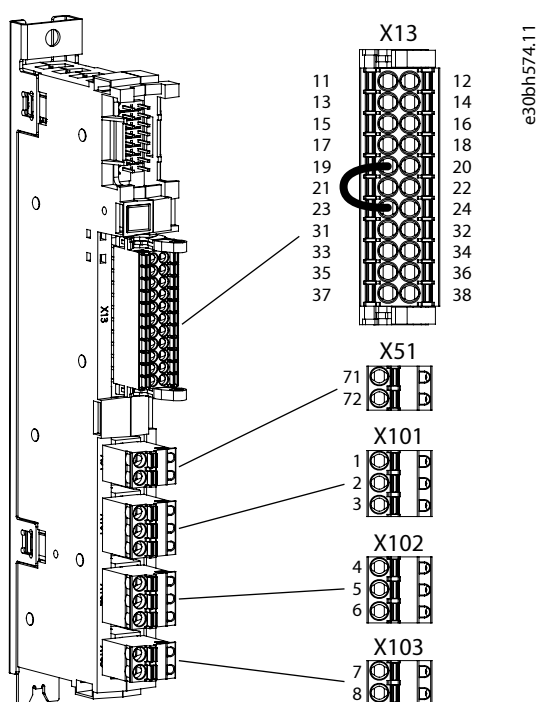

Figure 58: I/O and Relay Option Terminal Block and Terminal Numbering

Table 25: I/O and Relay Option Signals

Terminal	Function	Connector type
X13	I/O terminal	2 x 11 spring force connector 0.2–1.5 mm ²
X51	Thermistor input	1 x 2 spring force connector 0.25–2.5 mm ²
X101	Relay 1	1 x 3 spring force connector 0.25–2.5 mm ²
X102	Relay 2	1 x 3 spring force connector 0.25–2.5 mm ²
X103	Relay 3	1 x 2 spring force connector 0.25–2.5 mm ²

Table 26: I/O Terminal Signals (X13)

Terminal	Function	Description
11	+24 V _{out}	Control voltage output.
12	+24 V _{out}	24 V DC (-15...+20%) Maximum current 200 mA Short-circuit protected
13	DI 1	Configurable digital input, galvanically isolated. 24 V DC, 0 < 5 V, 1 > 15 V. Input load 7.5 mA constant current + 10 kΩ resistive load, maximum pulse frequency 100 kHz.
14	DI 2	
15	DI 3	
16	DI 4	
17	DI 5	
18	DI 6	
19	DGND	Digital input ground, not isolated by default.
20	DGND	When using the internal +24 V _{out} supply, connect the external jump wire between DGND and GND. When using the external +24 V DC supply, remove the external jump wire between DGND and GND.
21	DO 1	Configurable digital output. ⁽¹⁾ Push-pull 24 V/50 mA Open collector (NPN/PNP) 48 V/50 mA Short-circuit protected
22	DO 2	
23	GND	I/O ground.
24	GND	Ground for digital outputs, +10 V Ref, +24 V _{out} , analog inputs, and analog outputs.
31	AO 1	Configurable analog output. Voltage mode: <ul style="list-style-type: none"> • 0...10 V • R_L ≥ 1 kΩ • Accuracy ≤ ± 0.5% of full scale • Short-circuit protected Current mode: <ul style="list-style-type: none"> • 0...20 mA • R_L ≤ 600 Ω • Accuracy ≤ ± 0.5% of full scale • Short-circuit protected
32	+10 V ref.	10 V (0...+3%), maximum current 10 mA

Table 26: I/O Terminal Signals (X13) (continued)

Terminal	Function	Description
33	AI 1	Configurable analog input.
34	AI 2	Voltage mode: <ul style="list-style-type: none"> • $0 \pm 10\text{ V}$ • Single-ended • $R_i \sim 10\text{ k}\Omega$ • Accuracy $\pm 0.5\%$ of full scale Current mode: <ul style="list-style-type: none"> • $0 \pm 20\text{ mA}$ • Differential • $R_i \sim 200\ \Omega$ • Accuracy $\pm 0.5\%$ of full scale
35	GND	I/O ground.
36	GND	Ground for digital outputs, +10 V Ref, +24 V _{out} , analog inputs, and analog outputs.
37	GND	
38	GND	

1) Digital outputs are not recommended for main circuit breaker control, use relay outputs instead.

Table 27: Thermistor Input Signals (X51)

Terminal	Function	Description
71	TI+	Thermistor input, galvanically isolated. $R_{\text{trip}} = 4\text{ k}\Omega$
72	TI-	

Table 28: Relay 1 Signals (X101)

Terminal	Function	Description
1	COM	Configurable relay output.
2	NO	Switching capacity: <ul style="list-style-type: none"> • 24 V DC/8 A • 250 V AC/8 A • 125 V DC/0.4 A Minimum switching load: 5 V/10 mA
3	NC	

Table 29: Relay 2 Signals (X102)

Terminal	Function	Description
4	COM	Configurable relay output.
5	NO	Switching capacity: <ul style="list-style-type: none"> • 24 V DC/8 A • 250 V AC/8 A • 125 V DC/0.4 A Minimum switching load: 5 V/10 mA
6	NC	

Table 30: Relay 3 Signals (X103)

Terminal	Function	Description
7	COM	Configurable relay output.
8	NO	Switching capacity: <ul style="list-style-type: none"> • 24 V DC/8 A • 250 V AC/8 A • 125 V DC/0.4 A Minimum switching load: 5 V/10 mA

8.9 I/O and Relay Option Interface

8.9.1 Analog Inputs

The I/O and Relay Option has 2 analog inputs that can be configured with the software to voltage input or current input. The [Table 31](#) shows the specification for the analog inputs.

The analog inputs are protected in overvoltage conditions.

Table 31: Analog Input Types, Values, and Tolerances

Parameter	Value
Measuring range: voltage mode	-10...+10 V
Measuring range: current mode	-20...+20 mA
Input impedance	Voltage mode \approx 10 k Ω
	Current mode \approx 200 Ω
Accuracy	0.5% of full scale
Reaction time	0...90% step: < 1 ms
Number of inputs	2
Overvoltage limit	+15/-15 V
Overcurrent limit	+32/-32 mA
Electrical fast transient (EFT)	2 kV

8.9.2 Analog Outputs

The I/O and Relay Option has 1 analog output that can be configured with the software to voltage output or current output. The [Table 32](#) shows the specification for the analog output.

The analog output is protected in overvoltage conditions.

Table 32: Analog Output Types and Values

Parameter	Value
Output Voltage Range	0...10 V
Output Current Range	0...20 mA
Accuracy	0.5% of full scale

Table 32: Analog Output Types and Values (continued)

Parameter	Value
Reaction time	0...90% step: <1 ms
Electrical fast transient (EFT)	2 kV

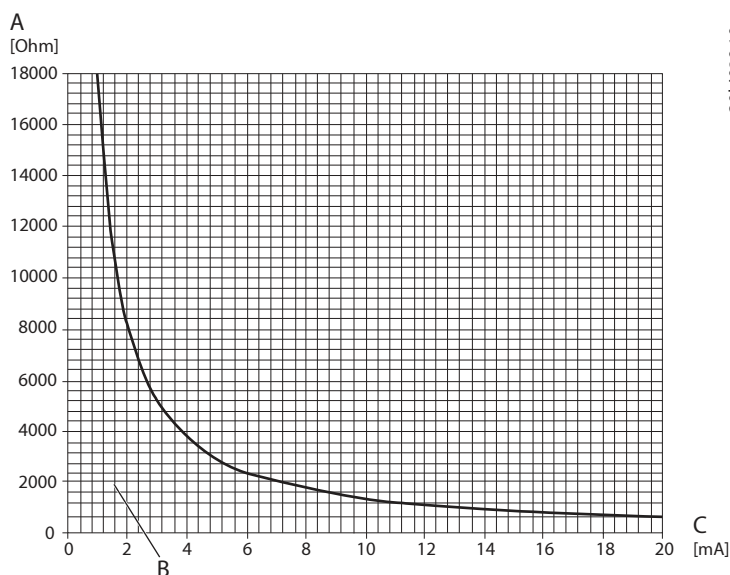

Figure 59: Allowed Load Resistance of Analog Output in Current Mode

A	Load resistance	B	Allowed load resistance
C	Output current		

8.9.3 Digital Inputs

The I/O and Relay Option has 6 digital inputs. By default, the digital inputs are not isolated, because there is an external wire between the connector pins 19 (D_{GND}) and 23 (GND). The digital inputs can be functionally isolated from the PCB ground of the I/O and Relay Option by removing the wire. The digital inputs are polarity free.

Digital inputs are overvoltage protected.

Table 33: Digital Inputs Logic Levels and Other Requirements

Parameter	Value
Recommended Operation Voltage	0...24 V +20%/-10%
Overvoltage Limit	33 V
Logic Level	0 = $V_{TL} \leq 5$ V 1 = $V_{TH} \geq 15$ V
Input Load	7.5 mA constant current and 10 k Ω resistive load
Reaction Time	< 5 μ s
Maximum Frequency	100 kHz
Electrical fast transient (EFT)	2 kV

8.9.4 Digital Outputs

The I/O and Relay Option has 2 digital outputs. The digital outputs are the push-pull type. The digital outputs can also be used as the open collector type.

The digital outputs are short-circuit protected.

Table 34: Digital Output Voltage and Current

Parameter	Value
Output Voltage	0 = max 2 V 1 = min 20 V
Rated Current	±50 mA
Overcurrent Limit	±80 mA
Maximum voltage when used as open collector output	48 V
Maximum Frequency	100 kHz
Electrical fast transient (EFT)	2 kV

1) Control unit power supply 24 V +20%/-10% and I_{load} max 50 mA

8.9.5 Relay Outputs

The I/O and Relay Option has 3 relay outputs. Relay 1 and Relay 2 have NO and NC contacts [1 form C (CO)]. Relay 3 has only an NO contact [1 form A (NO)]. The relay output interface is reinforced for system voltages ≤ 300 V. The lifetime for relays is 100.000 cycles.

Table 35: Relay Output Values

Parameter	Value
Rated Voltage	250 V AC
Max. Switching Voltage	400 V AC
Rated Current	8 A
Breaking Capacity Max	2000 VA
Operate Time Max.	9 ms
Release Time Max.	5 ms
DC Breaking Capacity	See Figure 60 .

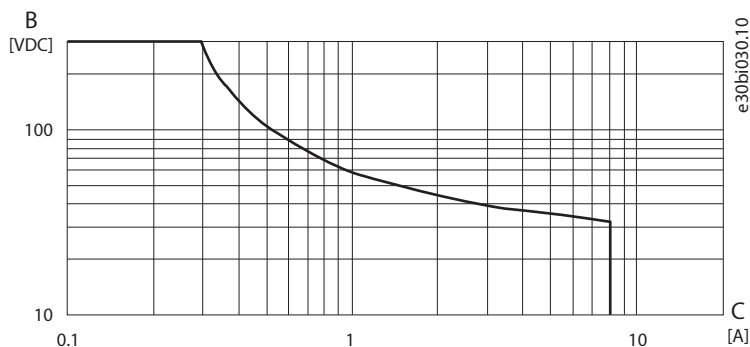

Figure 60: Maximum DC Load Breaking Capacity

B DC voltage C DC current

8.9.6 Analog Reference Voltage Output

The I/O and Relay Option contains 1 analog reference voltage output.

Table 36: Analog Reference Voltage Output Values

Parameter	Value
Nominal Voltage	10 V
Accuracy	-3...+3% of nominal voltage
Maximum Output Current	10 mA
Short Circuit Current	13 mA
Electrical fast transient (EFT)	2 kV

8.9.7 24 V DC Voltage Output

The I/O and Relay Option contains 1 voltage output of 24 V DC.

Table 37: 24 V DC Voltage Output

Parameter	Value
Nominal Voltage	24 V
Accuracy	-15...+20%
Maximum Output Current	200 mA
Short Circuit Current	250 mA
Electrical fast transient (EFT)	2 kV

8.9.8 Thermistor Input

The I/O and Relay Option contains 1 thermistor input. Thermistor input has basic isolation for system voltages ≤ 600 V and reinforced isolation for system voltages ≤ 300 V (OVC III 3000 m). For system voltage of 600 V, supplementary insulation is necessary at the motor end.

Table 38: Thermistor Input

Parameter	Value
Electrical fast transient (EFT)	2 kV
Sensor	R_{trip} 4.0 k Ω (PTC)

8.10 Assembling the Control Unit Mounting Plates

Use these instructions to assemble the mounting plate of the modular control unit. All the parts can be found in the accessories bag.

1. Assemble the mounting plate as shown in the illustration.
 - a. Attach the base grounding plate into the mounting plate.
 - b. Align the cable clamps in the holes in a wave-like form and attach with screws.
 - c. Attach the grounding plate extension onto the base grounding plate with 2 screws.
 - d. Attach the cable clamps with screws.

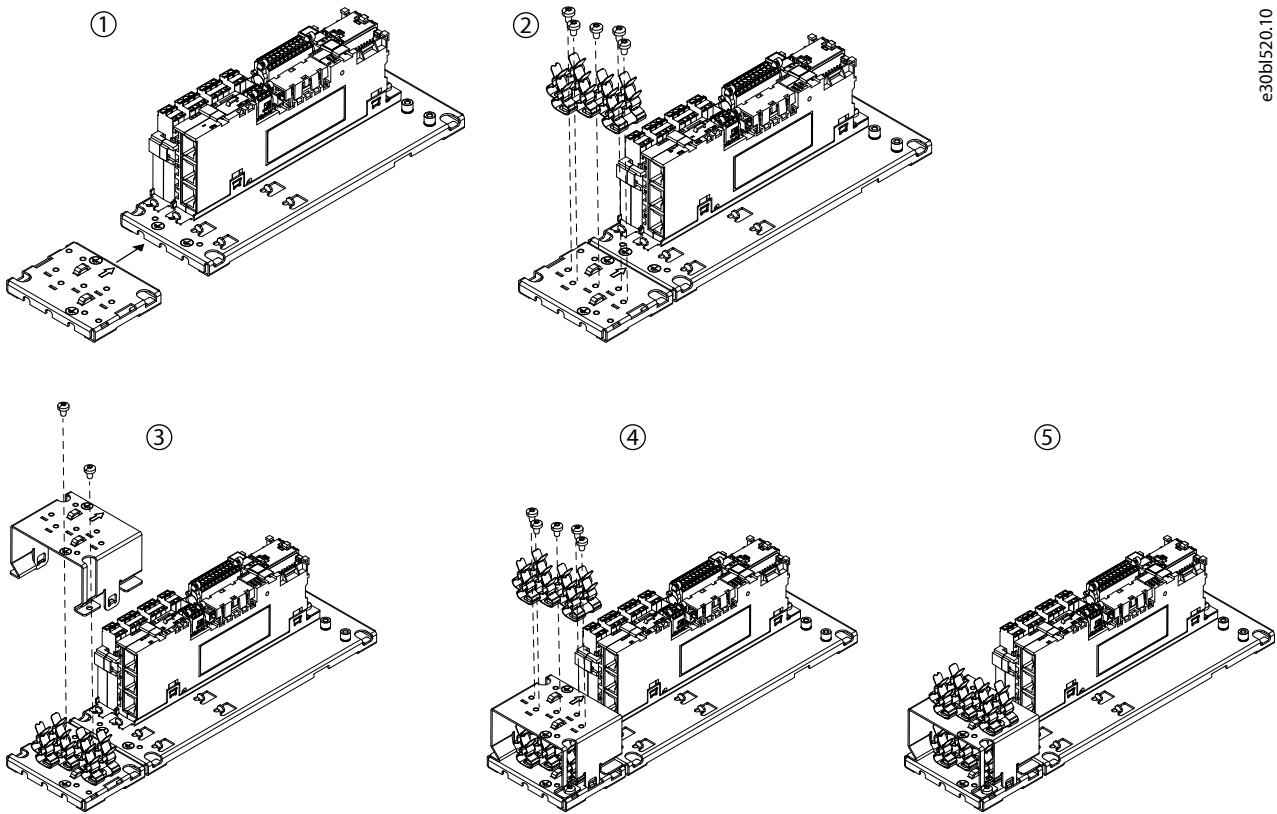

e30bi520.10

Figure 61: Assembling the Mounting Plate

8.11 Attaching the Control Unit Mounting Plates

Use these instructions to attach 2 or several mounting plates to each other, and to install mounting plates to the cabinet. All the parts can be found in the accessories bag.

1. Install the mounting plates to each other by fitting the sides together.

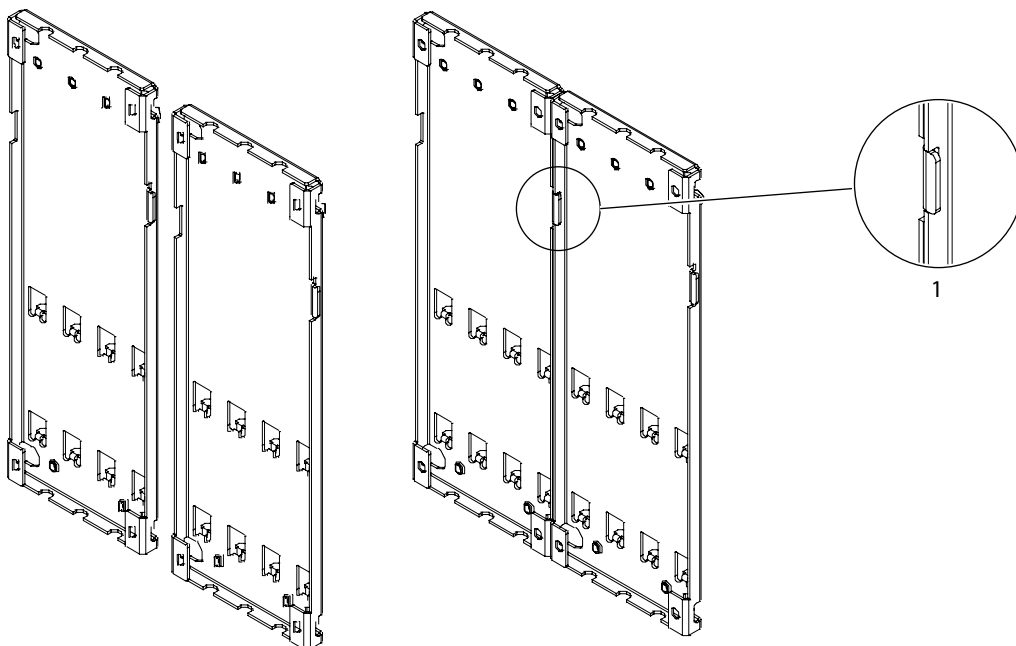

e30bi581.11

Figure 62: Attaching Mounting Plates to Each Other

1 Lip

2. Attach the mounting plates onto the cabinet with screws by the 4 mounting holes in the corners of the mounting plates.

The screws are not included in the delivery. Use an M4/M5 screw.

8.12 Installing the Control Unit

Install the control unit to the selected location. Use the 4 mounting holes in the corners of the mounting plate.

8.13 Installing Boards to the Modular Control Unit

NOTICE

DAMAGE TO OPTION BOARDS

Do not install, remove, or replace option boards on the drive when the power is on. Doing this can cause damage to the boards.

- Switch off the AC drive before installing, removing, or replacing option boards on the drive.

NOTICE

For best performance, install the Option Extender OC7F2 next to the control unit in 1 of the first 2 slots.

1. Remove the screw that is pre-attached to the fixing point at the top of the mounting plate and keep it.
2. Slide the lower edge of the board to the mounting plate fixing point.

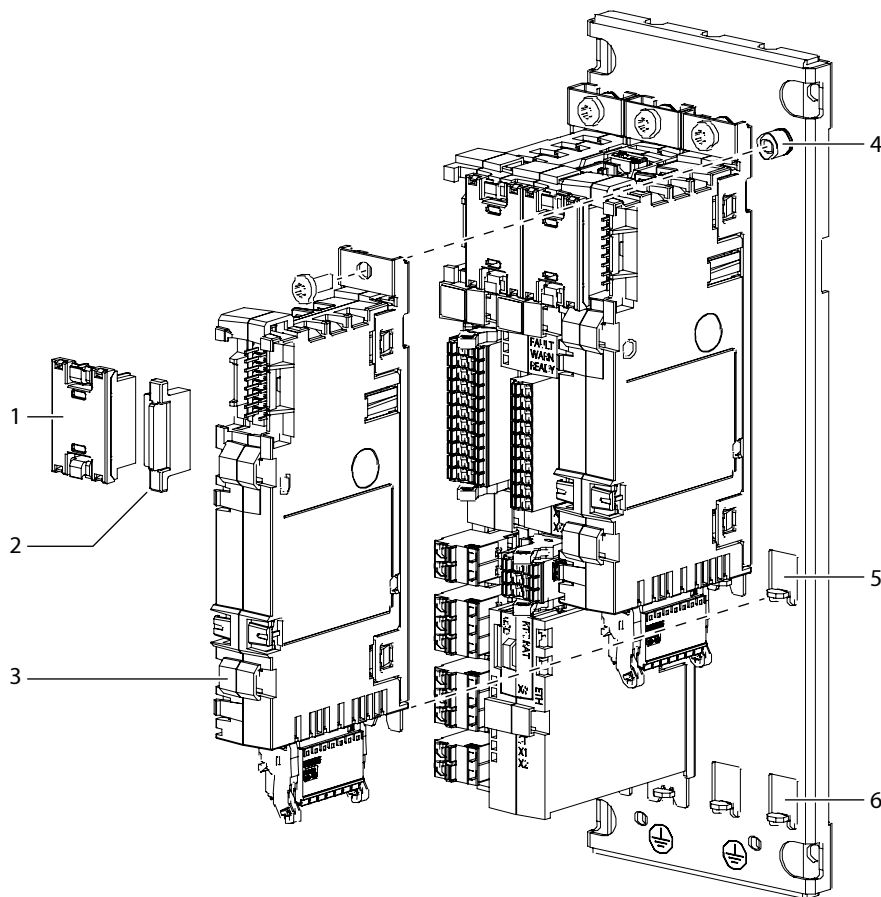

Figure 63: Installing a Board to the Modular Control Unit Mounting Plate

1	Option connector	2	Option terminal cover
3	Option board	4	Fixing point at the top
5	Fixing point at the middle	6	Fixing point at the bottom

- Use the screw to attach the board to the fixing point at the top.
- Attach an option connector to the newly installed board and the board next to it.
- Attach option terminal covers to the empty terminals.

8.14 Connecting the Fieldbus Cable and the Fiber Cables

- Connect the PLC to the Ethernet port X1 or X2 in the control board with a fieldbus cable.
- Connect the terminal X80 in the control board to the terminal X90 in the star coupler board with a fiber cable.
- Connect the terminals X301–X316 in the star coupler board to the power units with fiber cables.

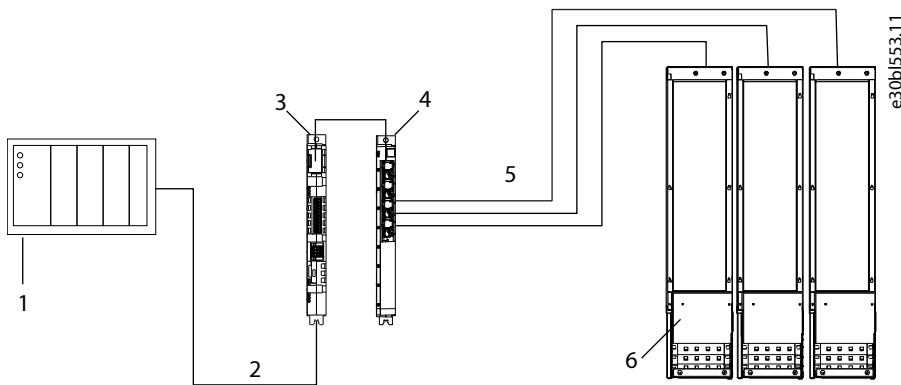

Figure 64: Connecting the Fieldbus Cable and the Fiber Cables

1	PLC (not included in the delivery)	2	Fieldbus cable
3	Control board	4	Star coupler board
5	Fiber cables	6	Power units

8.15 Installing the Control Cables into the Control Terminals

- Install the control cables into the control terminals.

See the pin numbering of the I/O and Relay Option in [8.8 I/O and Relay Option Connections](#).

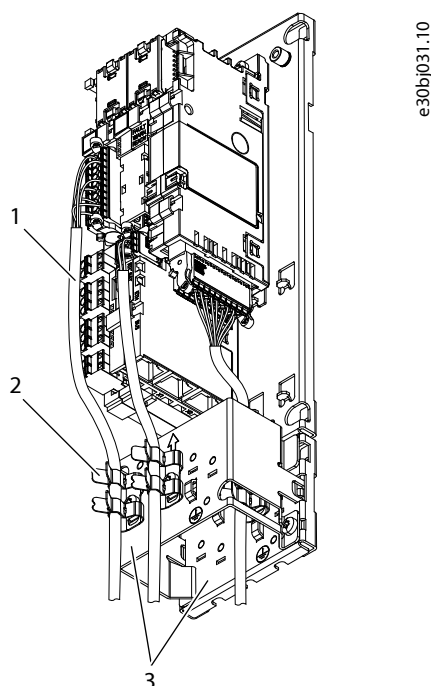
Figure 65: Example of Installing the Control Cables

1	Control cable	2	Cable clamp
3	Grounding plates		

- Strip the control cables. Attach the control cables to the cable clamps on the suitable grounding plate.

The lower part of the cable clamp fixes the cable to the plate and provides strain relief. The upper part provides ~360° grounding for the cable shield.

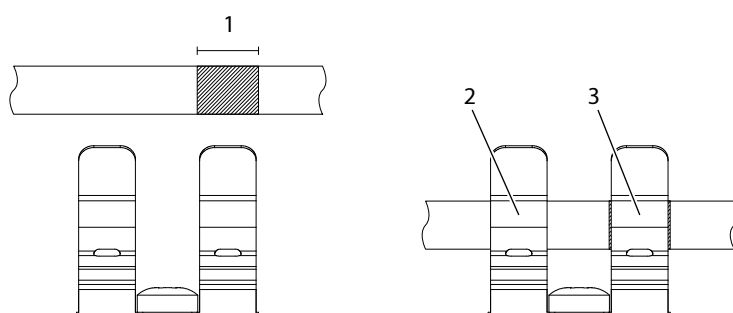
Figure 66: Stripping the Cable and Using the Grounding Plates

1	Stripping length, 10 mm (0.4 in)	2	Strain relief
3	Grounding		

8.16 Connecting the Control Panel

- Connect the control panel to the terminal X9 in the modular control unit with a panel cable adapter.

8.17 Fiber Cable Requirements

The required fiber cable type is LC duplex cable assembly 0.5NA SI-POF.

The installation temperature of the fiber cable is -40...+85 °C (-40...+185 °F). The minimum bending radius is 25 mm (1.0 in).

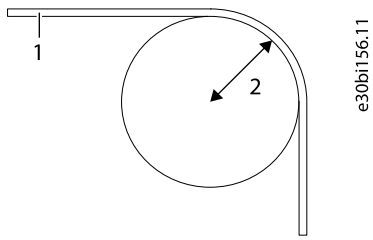

Figure 67: Bending Radius of the Fiber Cables

1	Cable	2	Bending radius (25 mm, 1.0 in)
---	-------	---	--------------------------------

9 Maintenance

9.1 Preventive Maintenance Recommendations

Generally, all technical equipment, including Danfoss AC drives, need a minimum level of preventive maintenance. To ensure trouble-free operation and long life of the drive, regular maintenance is recommended. It is also recommended as a good service practice to record a maintenance log with counter values, date, and time describing the maintenance and service actions.

Danfoss recommends the following inspections and service intervals for air-cooled drives/systems.

NOTICE

The service schedule for part replacements can vary depending on operating conditions. Under specific conditions, the combination of stressful operation and environmental conditions work together to reduce the lifetime of the components significantly. These conditions can include, for example, extreme temperature, dust, high humidity, hours of use, corrosive environment, and loading.

For operation in stressful conditions, Danfoss offers the DrivePro® Preventive Maintenance service. DrivePro® services extend the lifetime and increase the performance of the product with scheduled maintenance including customized part replacements. DrivePro® services are tailored to the specific application and operating conditions.

Table 39: Maintenance Schedule for Air-cooled Drives

Component	Inspection interval ⁽¹⁾	Service schedule ⁽²⁾	Preventive maintenance actions
Installation			
Visual inspection	1 year	–	Check for the unusual, for example, for signs of overheating, aging, corrosion, and for dusty and damaged components.
Auxiliary equipment	1 year	According to manufacturer recommendations	Inspect equipment, switchgear, relays, disconnects, or fuses/circuit breakers. Examine the operation and condition for possible causes of operational faults or defects. The continuity check on fuses must be performed by trained service personnel.
EMC consideration	1 year	–	Inspect the wiring regarding the electromagnetic capability and the separation distance between control wiring and power cables.
Cable routing	1 year	–	Check for parallel routing of motor cables, mains wiring, and signal wiring. Avoid parallel routing. Avoid routing cables through free air without support. Check for aging and wearing of the cable insulation.
Control wiring	1 year	–	Check for tightness, damaged or crimped wires, or ribbon wires. Terminate the connections correctly with solid crimped ends. The use of shielded cables and grounded EMC plate, or a twisted pair is recommended.
Clearances	1 year	–	Check that the external clearances for proper airflow for cooling follow the requirements for the frame and product type. For clearances, refer to the local design regulations.
Sealing	1 year	–	Check that the sealing of the enclosure, the covers, and the cabinet doors are in good condition.
Corrosive environments	1 year	–	Conductive dust and aggressive gases, such as sulphide, chloride, and salt mist, can damage the electrical and mechanical components. Air filters do not remove air-borne corrosive chemicals. Act based on the findings.

Table 39: Maintenance Schedule for Air-cooled Drives (continued)

Component	Inspection interval ⁽¹⁾	Service schedule ⁽²⁾	Preventive maintenance actions
Drive			
Programming	1 year	–	Check that the AC drive parameter settings are correct according to the motor, drive application, and I/O configuration. Only trained service personnel are allowed to perform this action.
Control panel	1 year	–	Check that the display pixels are intact. Check the event log for warnings and faults. Repetitive events are a sign of potential issues. If necessary, contact a local service center.
Drive cooling capacity	1 year	–	Check for blockages or constrictions in the air passages of the cooling channel. The heat sinks must be free of dust and condensation.
Capacitors, DC link	1 year	8–15+ years	The expected lifetime of the capacitors depends on the loading profile of the application and the ambient temperature. For applications with heavy loads in demanding environments or high ripple currents, replace electrolytic capacitors every 8 years and plastic foil capacitors every 12 years. If within the specifications of the drive type, replace every 10–15+ years. Only trained service personnel are allowed to perform this action.
Cleaning and filters	1 year	–	Clean the interior of the enclosure annually, and more frequently if necessary. The amount of dust in the filter or inside the enclosure is an indicator for when the next cleaning or filter replacement is required.
Fans	1 year	3–10 years	Inspect the condition and operational status of all cooling fans. With the power off, the fan axis should feel tight, and spinning the fan with a finger, the rotation should be almost silent and not have abnormal rotation resistance. When in RUN mode, fan vibration, excessive or strange noise is a sign of the bearings wearing, and the fan must be replaced.
Grounding	1 year	–	The drive system requires a dedicated ground wire connecting the drive, the output filter, and the motor to the building ground. Check that the ground connections are tight and free of paint or oxidation. Daisy-chain connections are not allowed. If applicable, braided straps are recommended.
PCB	1 year	10–12 years	Visually inspect the printed circuit boards for signs of damage or degrading due to aging, corrosive environments, dust, or environments with high temperatures. Only trained service personnel are allowed to perform the inspection and service action.
Power cables and wiring	1 year	–	Check for loose connections, aging, insulation condition, and proper torque to the drive connections. Check for proper rating of fuses and continuity check. Observe if there are any signs of operation in a demanding environment. For example, discoloration of the fuse housing can be a sign of condensation or high temperatures.
Vibration	1 year	–	Check for abnormal vibration or noise coming from the drive to ensure that the environment is stable for electronic components.
Insulator gaskets	1 year	10–15 years	Inspect the insulators for signs of degradation due to high temperature and aging. Replacement is based on findings or done at the same time as DC capacitor replacement. Only trained service personnel are allowed to perform this action.
Batteries	1 year	7–10 years	Replace the batteries according to the manufacturer recommendation. Replace the real-time clock battery in the control unit every 7–10 years.
Spare parts			

Table 39: Maintenance Schedule for Air-cooled Drives (continued)

Component	Inspection interval ⁽¹⁾	Service schedule ⁽²⁾	Preventive maintenance actions
Spare parts	1 year	2 years	Stock spares in their original boxes in a dry and clean environment. Avoid hot storage areas. Electrolytic capacitors require reforming as stated in the service schedule. The reforming must be performed by trained service personnel.
Exchange units and units stored for long periods before commissioning	1 year	2 years	Visually inspect for signs of damage, water, high humidity, corrosion, and dust within the visual field of view without disassembly. The exchange units with mounted electrolytic capacitors require reforming as stated in the service schedule. The reforming must be performed by trained service personnel.

1) Defined as the time after the commissioning/startup or the time from the previous inspection.

2) Defined as the time after the commissioning/startup or the time from the previous service schedule actions.

9.2 Using the Product Modified Label

In the accessories bag, there is also a "product modified" label. The function of the label is to tell the service personnel about the changes that are made in the AC drive.

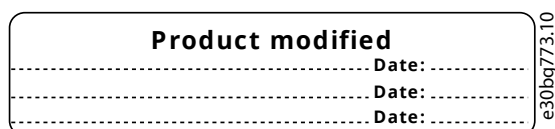

Figure 68: The Product Modified Label

1. Attach the label on the side of the AC drive, in a place where it is easy to find.
 - a. Attach the label, for example, next to the other labels on the power unit.
2. If changes are made to the AC drive, write the change and date on the label.

9.3 Replacing the RTC Battery

The real-time clock (RTC) battery can be used to provide a reliable power source for the RTC. If power is lost in the control unit, the RTC battery keeps the internal real time. The time is used for scheduled activities and timestamping occurrences based on application needs. The RTC battery is optional and comes preinstalled if the option is selected.

CAUTION

RISK OF FIRE AND EXPLOSION

- Replace the battery with a Panasonic BR1632A (3 V, 125 °C) coin-cell battery only. Using another battery may present a risk of fire or explosion. Only qualified personnel can exchange the battery.
- For detailed safety information, refer to the documentation provided with the battery.

CAUTION

RISK OF FIRE OR EXPLOSION

- Do not recharge or disassemble the battery, or dispose of it in fire.

1. Locate the RTC battery holder on the control board of the control unit.
2. Pull from the handle next to the text RTC BAT.

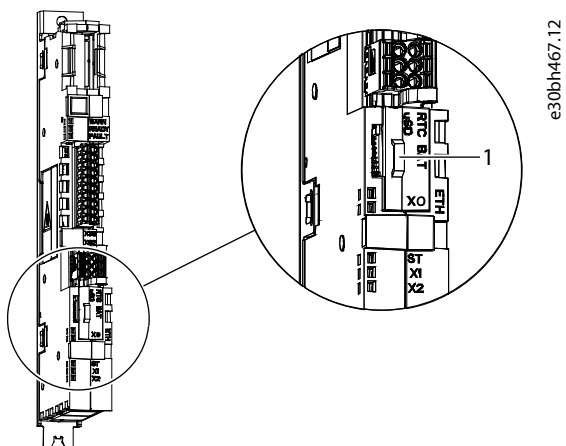

Figure 69: Location of the RTC Battery

-
- 1 The handle
-

➡ The battery holder slides out.

3. To remove the battery, push it on the tooth side and slide it out of the plastic holder.

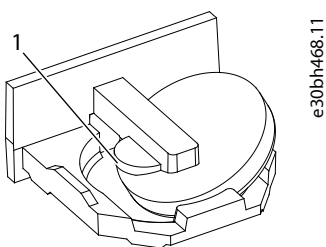

Figure 70: Replacing the Battery

-
- 1 The tooth
-

4. To put a new battery in place, start from the opposite side and slide it into the slot in the holder, the plus side towards the tooth.

The correct battery type is a coin type lithium battery BR1632.

5. Push the holder back into the control board.

9.4 Removing the Fan Assembly

1. Remove the 2 M5x10 screws (141L3849) and open the fan cover.

Use a TX25 bit to remove the screws.

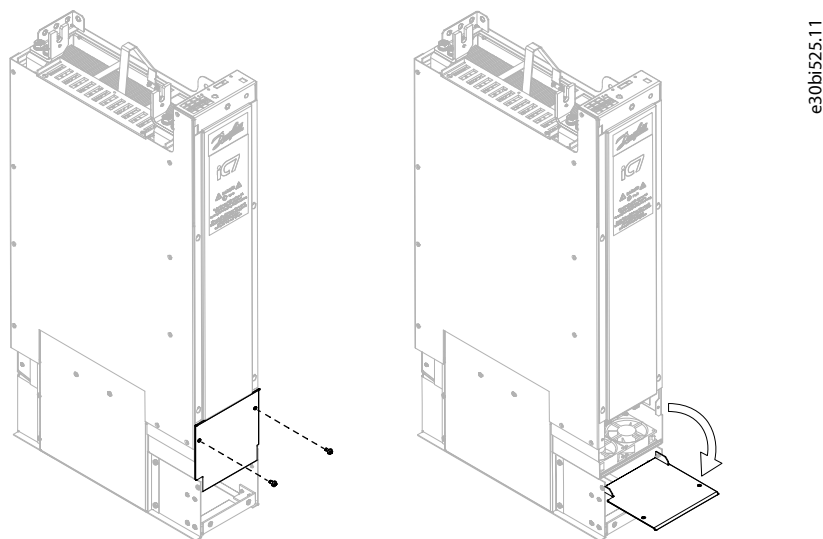

Figure 71: Releasing and Opening the Fan Cover

2. Disconnect the fan supply cables from the fan power supply.

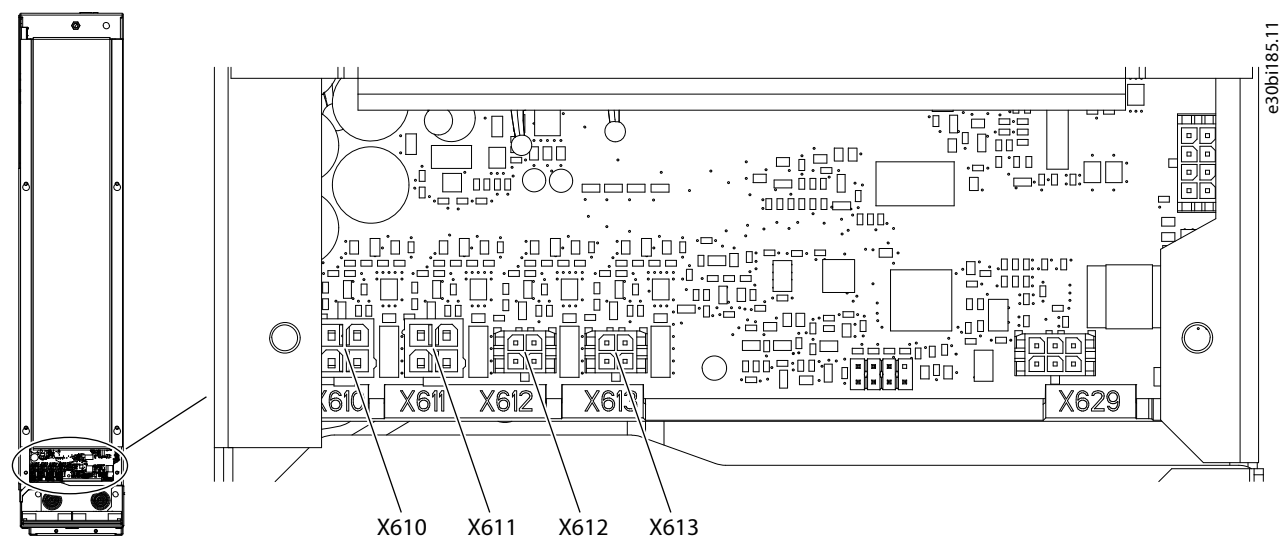

Figure 72: Fan Supply Terminals

X610	Supply to main cooling fan	X611	Supply to main cooling fan
X612	Supply to auxiliary compartment cooling fan	X613	Supply to auxiliary compartment cooling fan

3. Release and pull out the fan assembly.

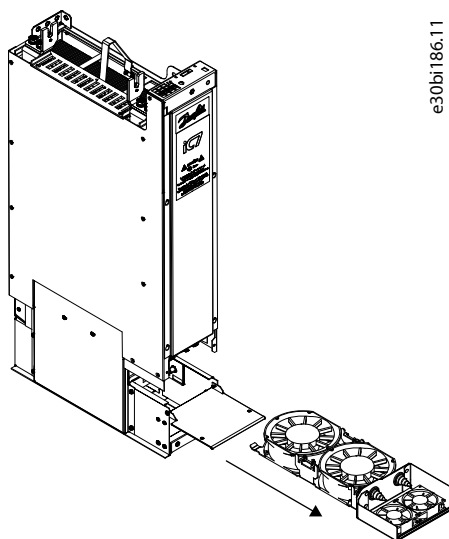

Figure 73: Removing the Fan Assembly

9.5 Installing MyDrive® Insight

1. To install the tool, go to <https://suite.mydrive.danfoss.com/content/tools>.
2. Install MyDrive® Insight.

For more information on how to use the tool, see the online help in MyDrive® Insight.

3. Use MyDrive® Insight to connect the drive to a PC.

9.6 Downloading the Software without the Mains Supply

Use these instructions to update the drive with new software without mains.

Before downloading the software, read all safety precautions in this guide and other guides available for this product.

1. Connect an external 24 V DC supply to terminals X67 and X80 of the power unit.
 - a. The supply must have $\pm 10\%$ voltage accuracy.
 - b. The supply current must be > 2.5 A per power unit, depending on the configuration.
 - c. If there is more than 1 power unit connected to the same control unit, connect an external 24 V DC supply to all the power units.
2. Commission the drive from MyDrive® Insight.
3. Disconnect the external 24 V DC supply from terminals X67 and X80 of the power unit.

9.7 Recommissioning of the Drive

To recommission the drive, use these instructions. There can be a need for recommissioning the drive even during the 1st startup if the hardware configuration has changed. The need is indicated on the control panel or through MyDrive® Insight. Recommissioning is needed, for example, when an option board is changed, or the LCL filter in use is not the same as in the factory commissioning.

1. Power up all system modules and LCL filters.
 - a. To power up the inverter module, use 1 of the following methods:

Connect the 24 V service voltage to terminals X67 and X80.

or

Connect the DC-link voltage to the DC-link busbars of the power units.

- b. To power up the AFE module, use 1 of the following methods:

Connect the 24 V service voltage to terminals X67 and X80.

or

Connect the external DC-link voltage to the DC-link busbars of the power units.

- c. To power up the LCL filter, use 1 of the following methods:

Connect the 24 V service voltage to terminal X80.

or

Connect the external DC-link voltage to the LCL fan supply terminal X121.

- o The supply must have $\pm 10\%$ voltage accuracy.
- o The supply current must be >2.5 A per power unit, depending on the configuration. This current is also enough for the control unit.
- o If there is more than 1 power unit connected to the same control unit, connect an external 24 V DC supply to all the power units.

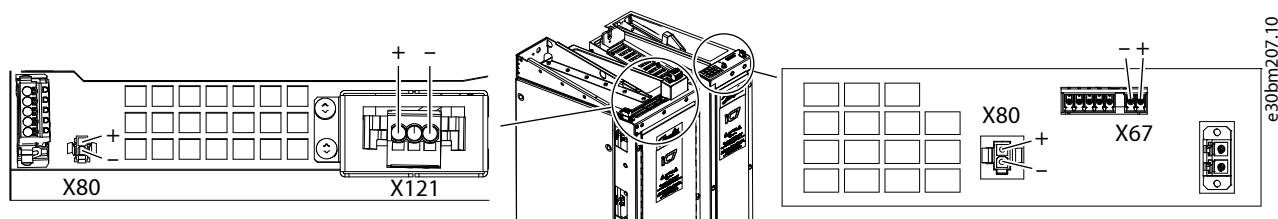

Figure 74: Service Voltage Terminals of the System Modules and LCL Filter

2. Commission the drive from MyDrive® Insight or the control panel.
3. Disconnect the external 24 V DC supply from terminals X67 and X80 of the system modules and LCL filters.

B Front C Back

D The front fixing beam can be rotated so that the screws can be attached from the front or from the top.

10.2.2 Dimensions of the Inverter Module, IM11

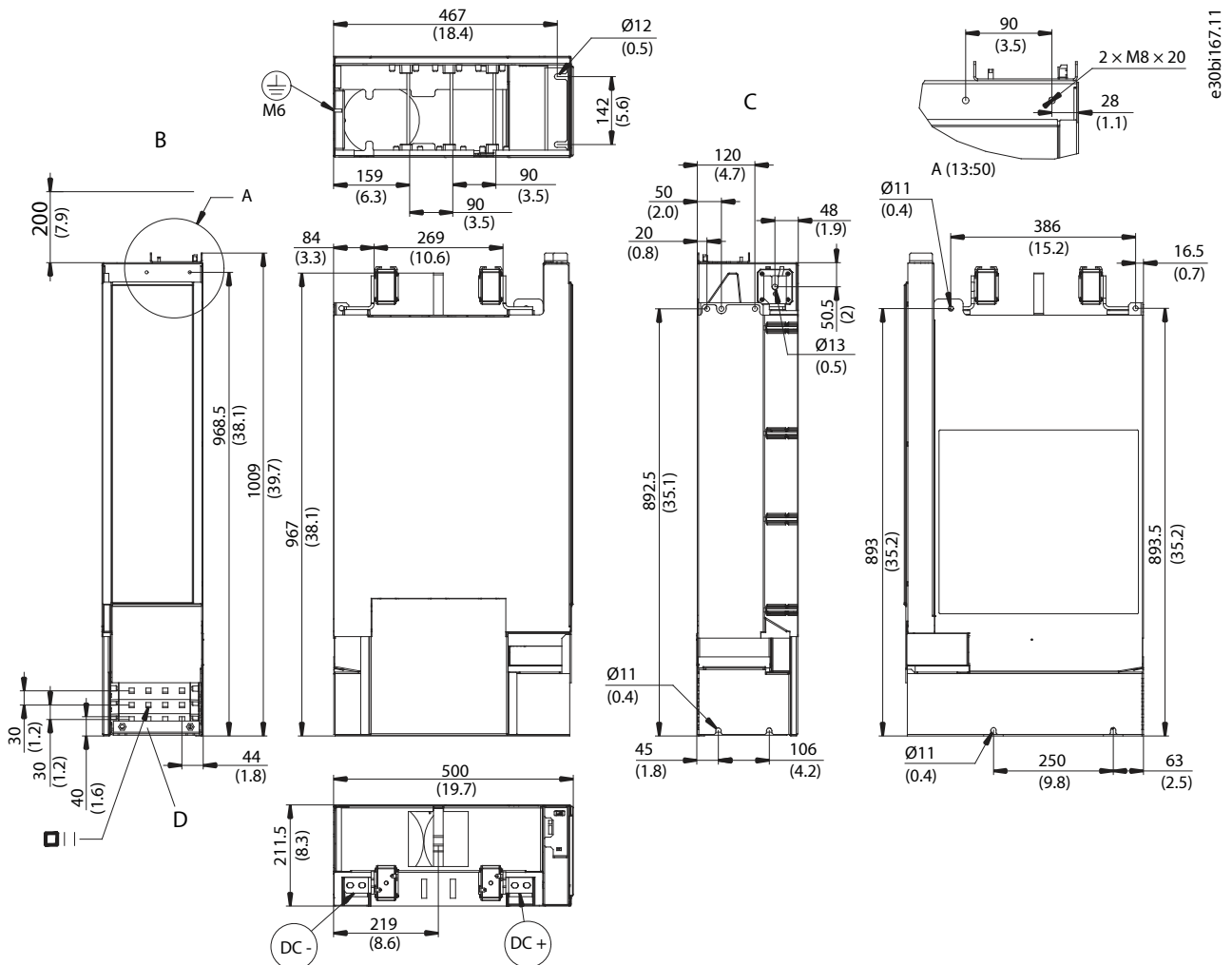
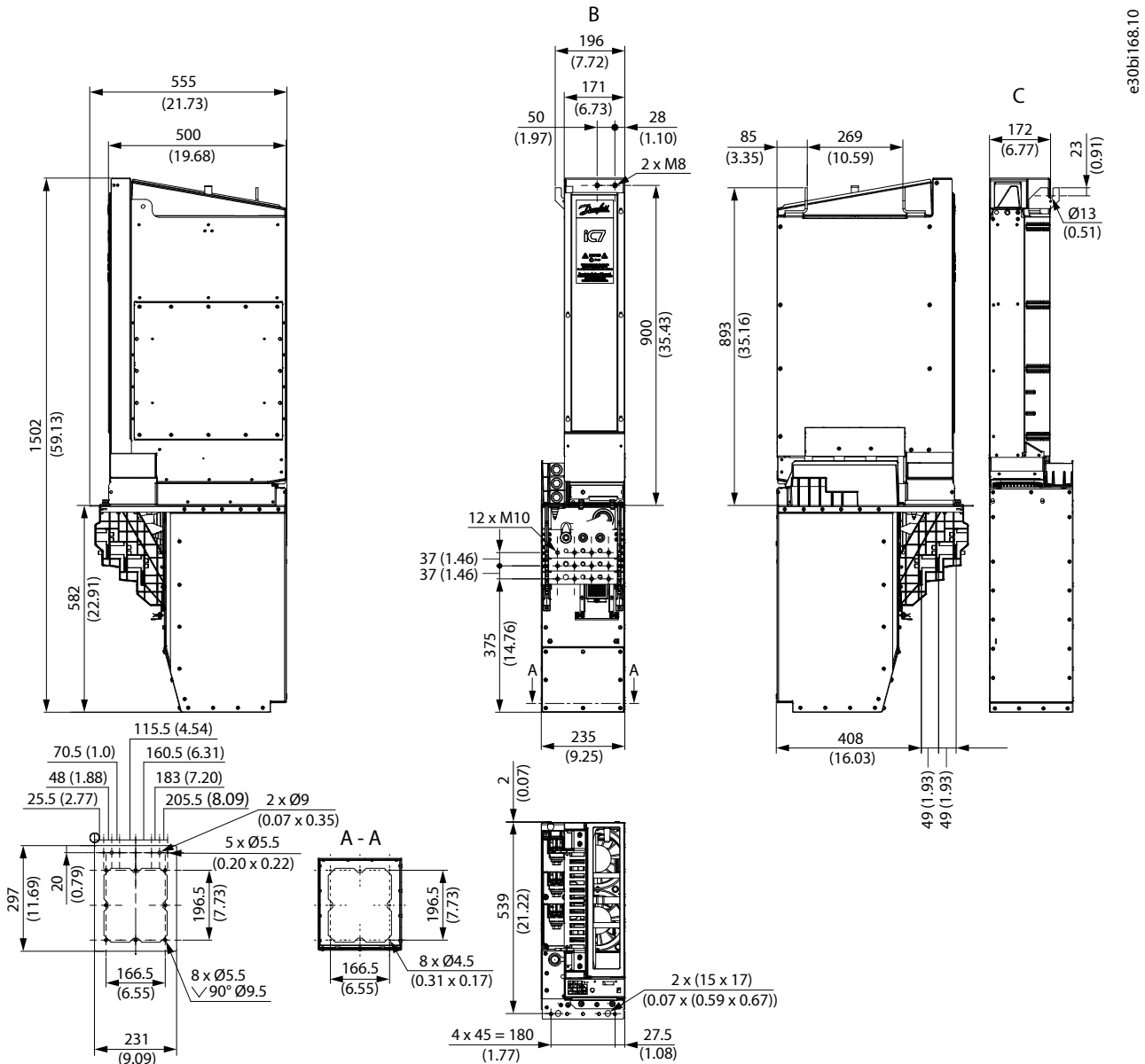

Figure 76: Dimensions of the Inverter Module in mm (in), IM11

B Front C Back

D The front fixing beam can be rotated so that the screws can be attached from the front or from the top.

10.2.3 Dimensions of the Inverter Module, IR10



e30bi168.10

Figure 77: Dimensions of the Inverter Module in mm (in), IR10

B	Front	C	Back
---	-------	---	------

The additional front fixing plate adds 2 mm (0.08 in) to the overall height. The plate is optional.

10.2.4 Dimensions of the Inverter Module, IR10 with Short Integration Unit (+AE01)

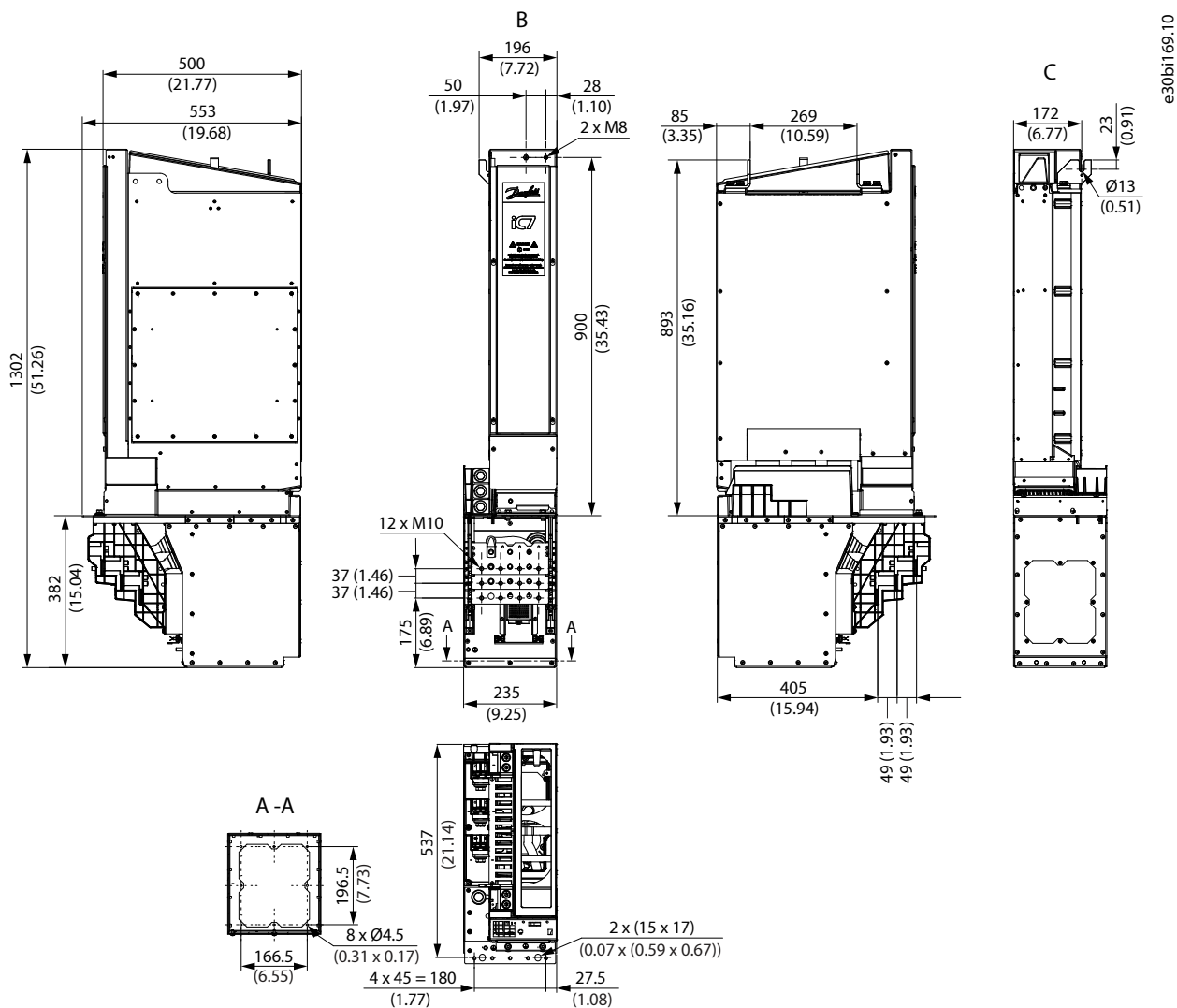
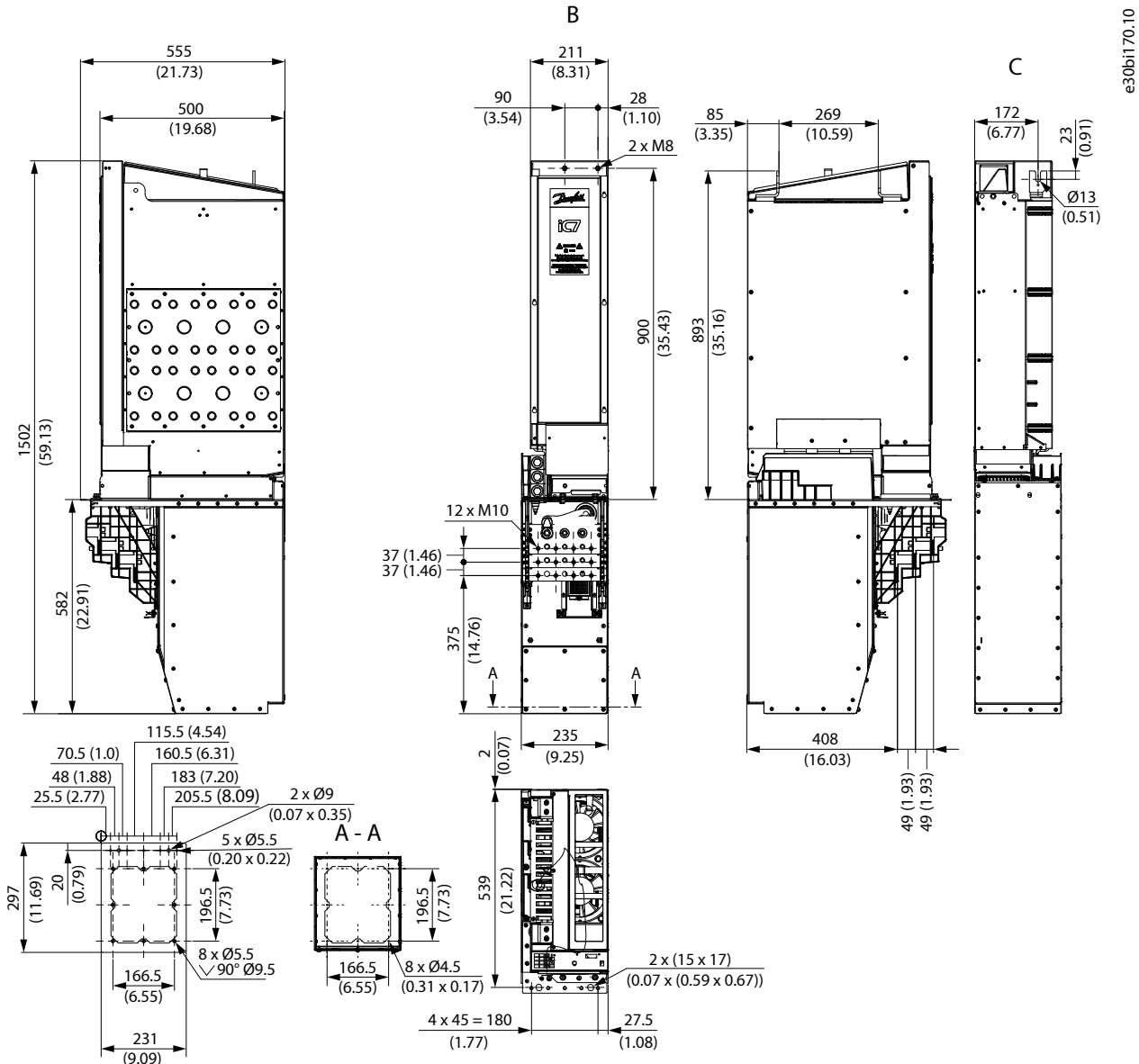

Figure 78: Dimensions of the Inverter Module in mm (in), IR10 with Short Integration Unit (+AE01)

B Front

C Back

10.2.5 Dimensions of the Inverter Module, IR11



e30bit170-10

Figure 79: Dimensions of the Inverter Module in mm (in), IR11

B	Front	C	Back
---	-------	---	------

The additional front fixing plate adds 2 mm (0.08 in) to the overall height. The plate is optional.

10.2.6 Dimensions of the Inverter Module, IR11 with Short Integration Unit (+AE01)

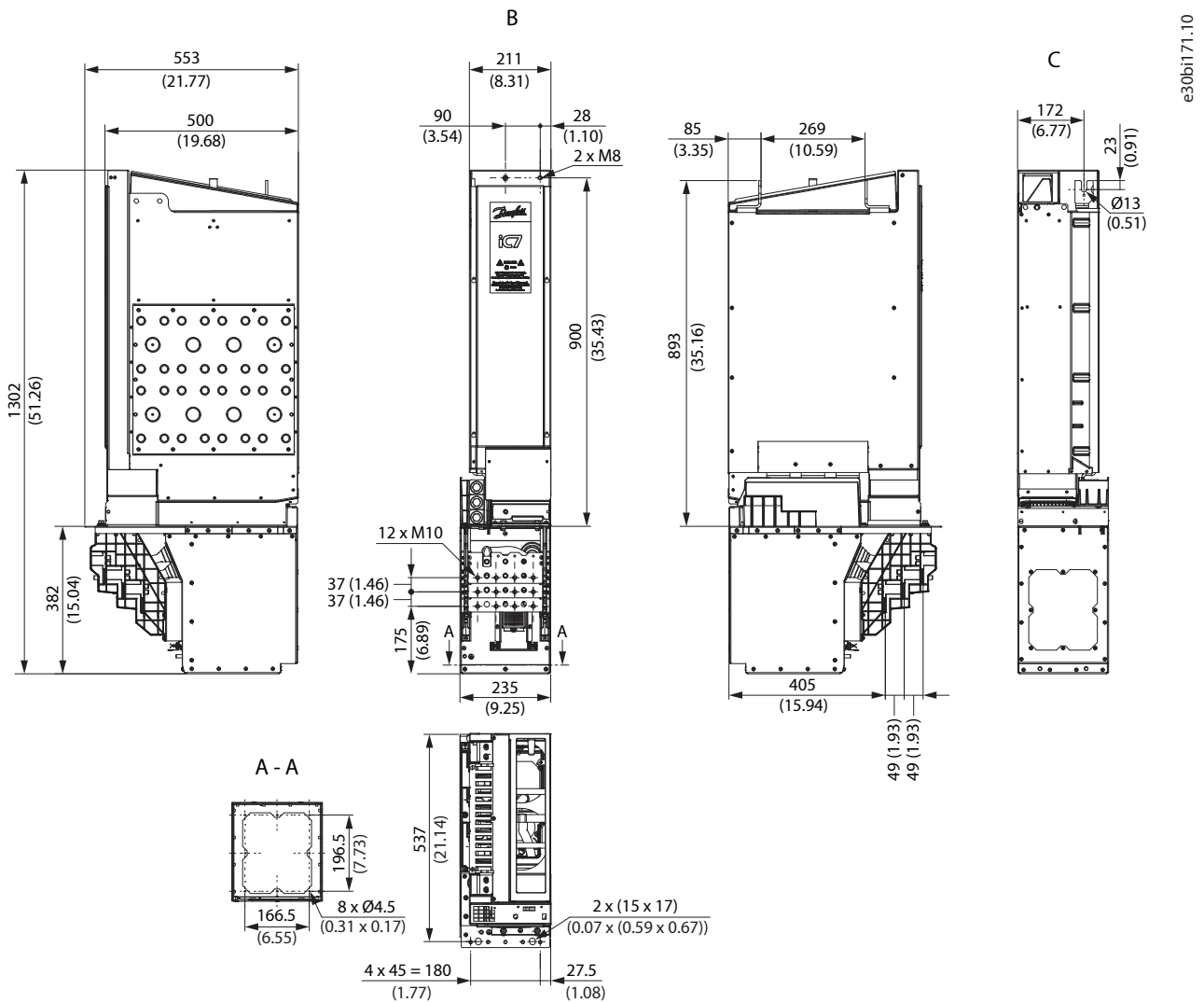

Figure 80: Dimensions of the Inverter Module in mm (in), IR11 with Short Integration Unit (+AE01)

B	C
Front	Back

10.2.8 Dimensions of the AFE Module, AR10, with the Short Integration Unit (+AE01)

e30bj598-10

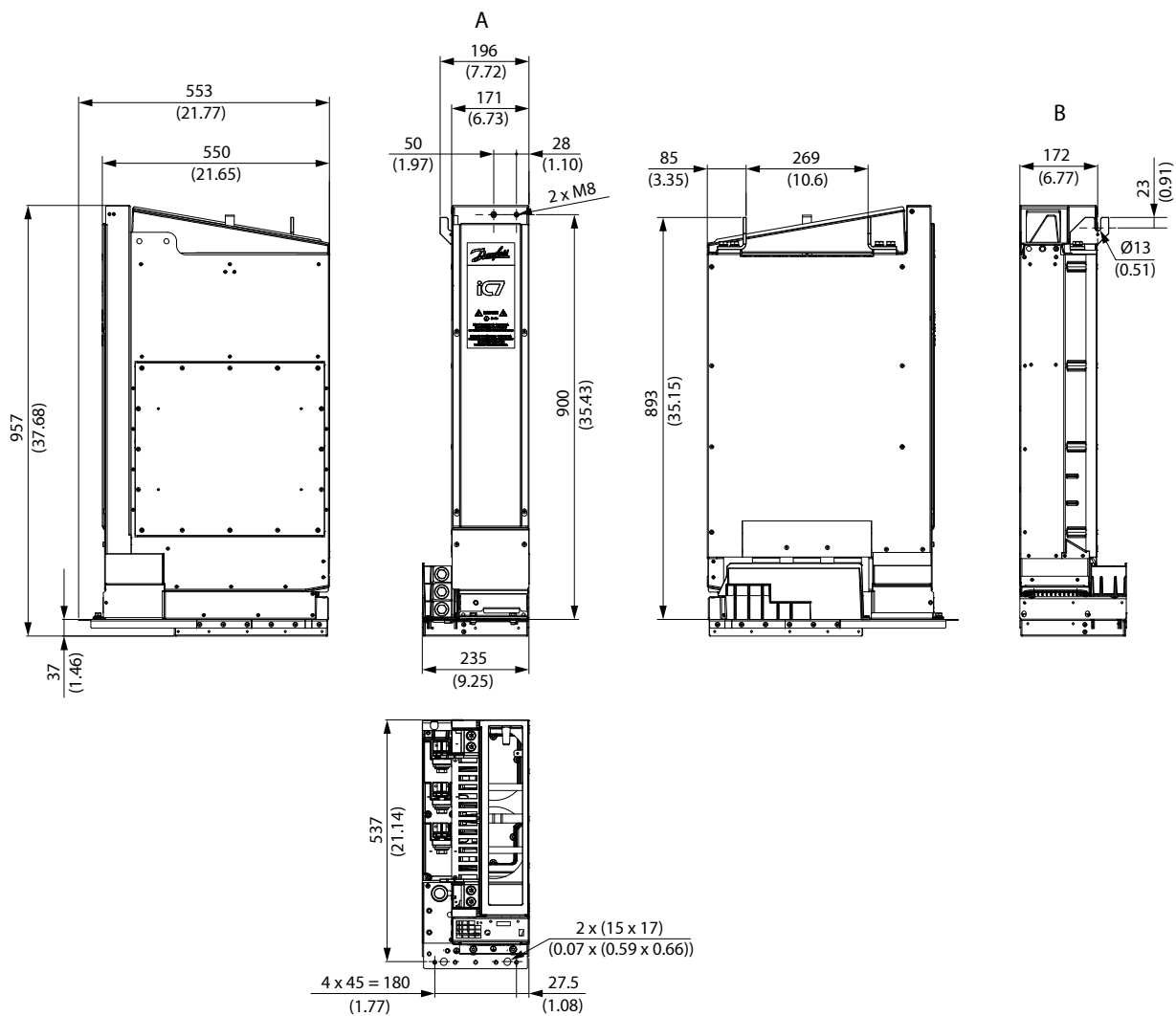

Figure 82: Dimensions of the AFE Module, AR10, with the Short Integration Unit (+AE01) in mm (in)

A Front

B Back

10.2.10 Dimensions of the AFE Module, AR11, with the Short Integration Unit (+AE01)

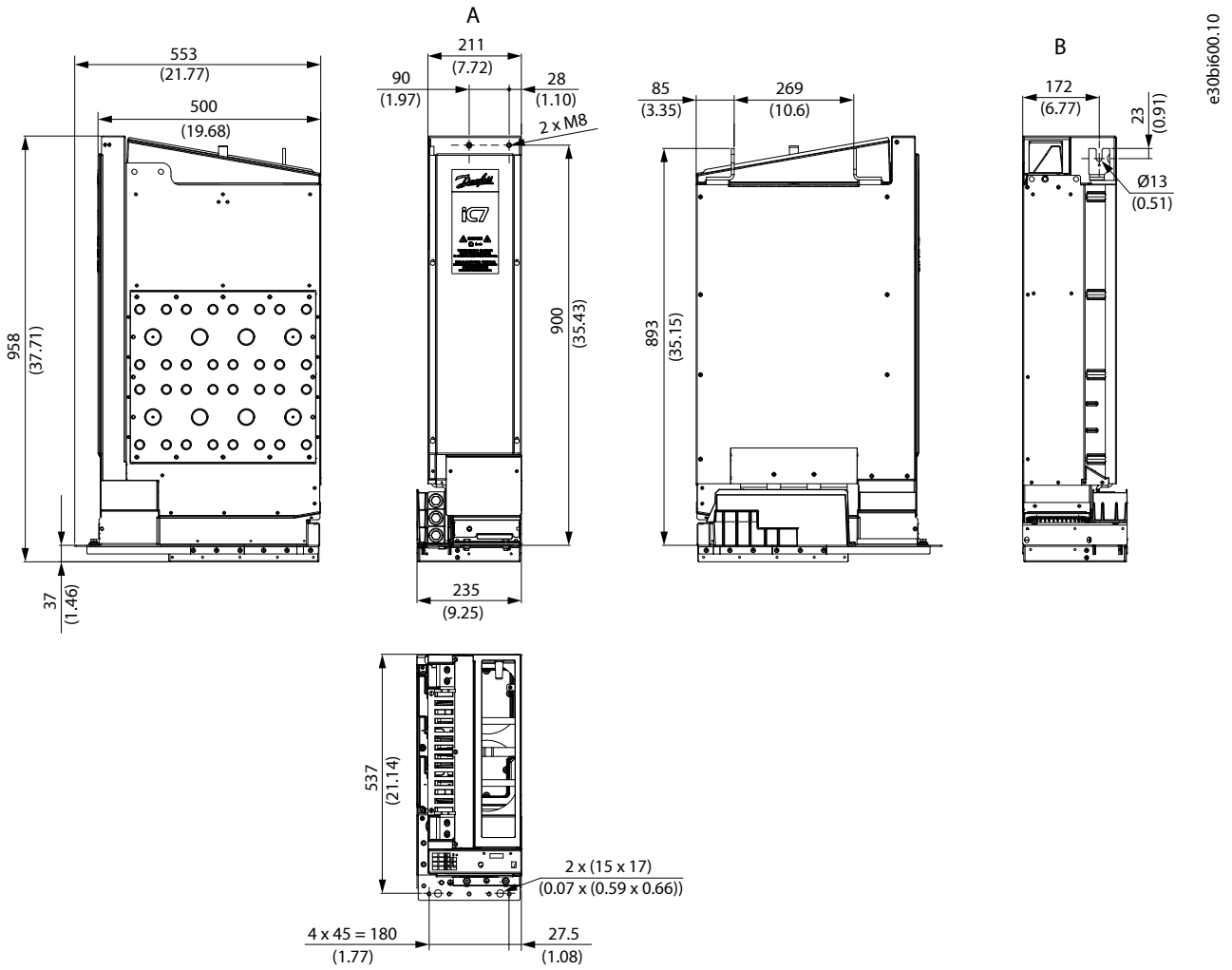

Figure 84: Dimensions of the AFE Module, AR11, with the Short Integration Unit (+AE01) in mm (in)

A	Front	B	Back
---	-------	---	------

10.2.11 Dimensions of the LCL Filter, LCL10, and the AFE Module, AR10

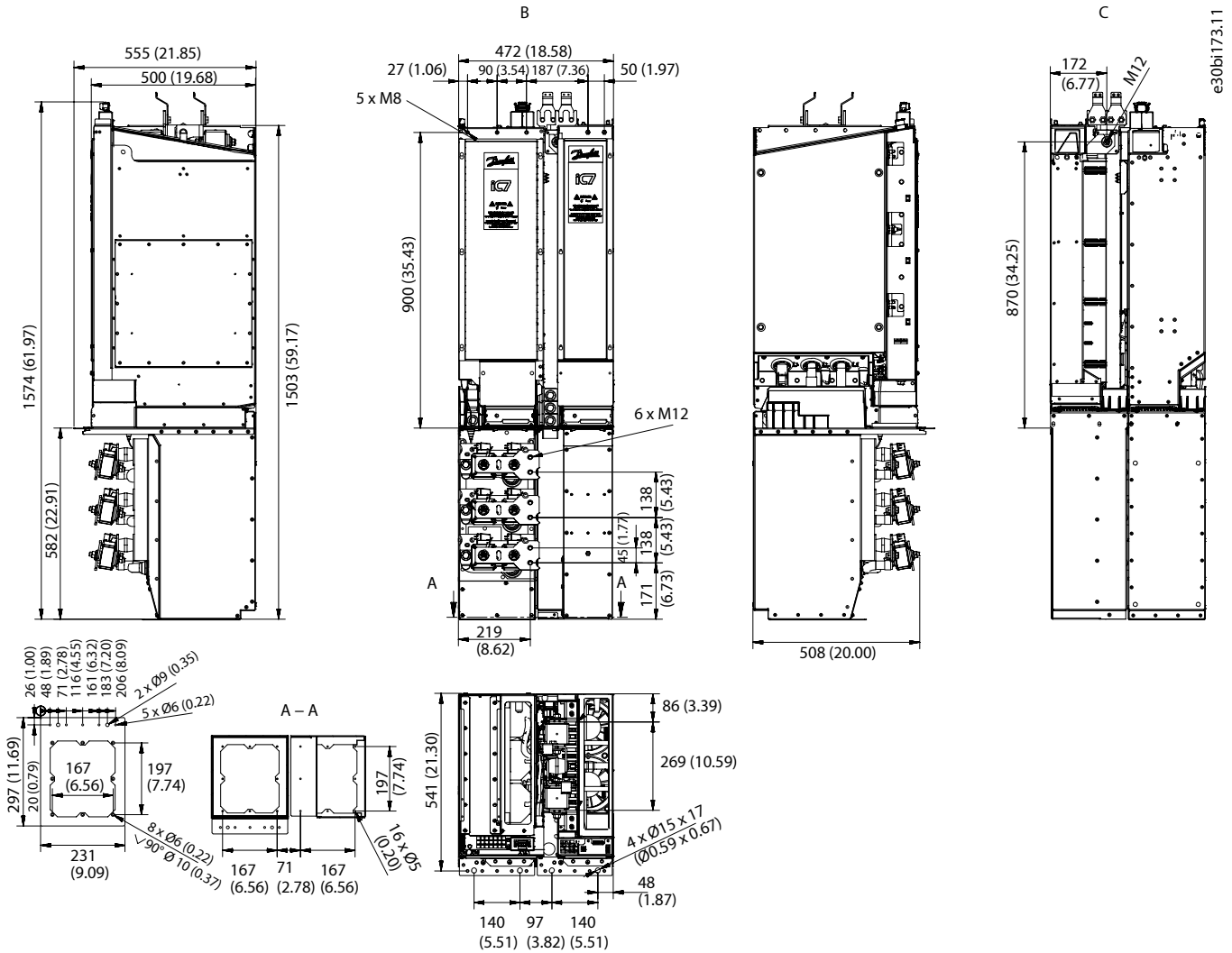

Figure 85: Dimensions of the LCL Filter, LCL10, and the AFE Module, AR10 in mm (in)

B	Front	C	Back
---	-------	---	------

10.2.12 Dimensions of the LCL Filter, LCL10, and the AFE Module, AR10, with the Short Integration Unit (+AE01)

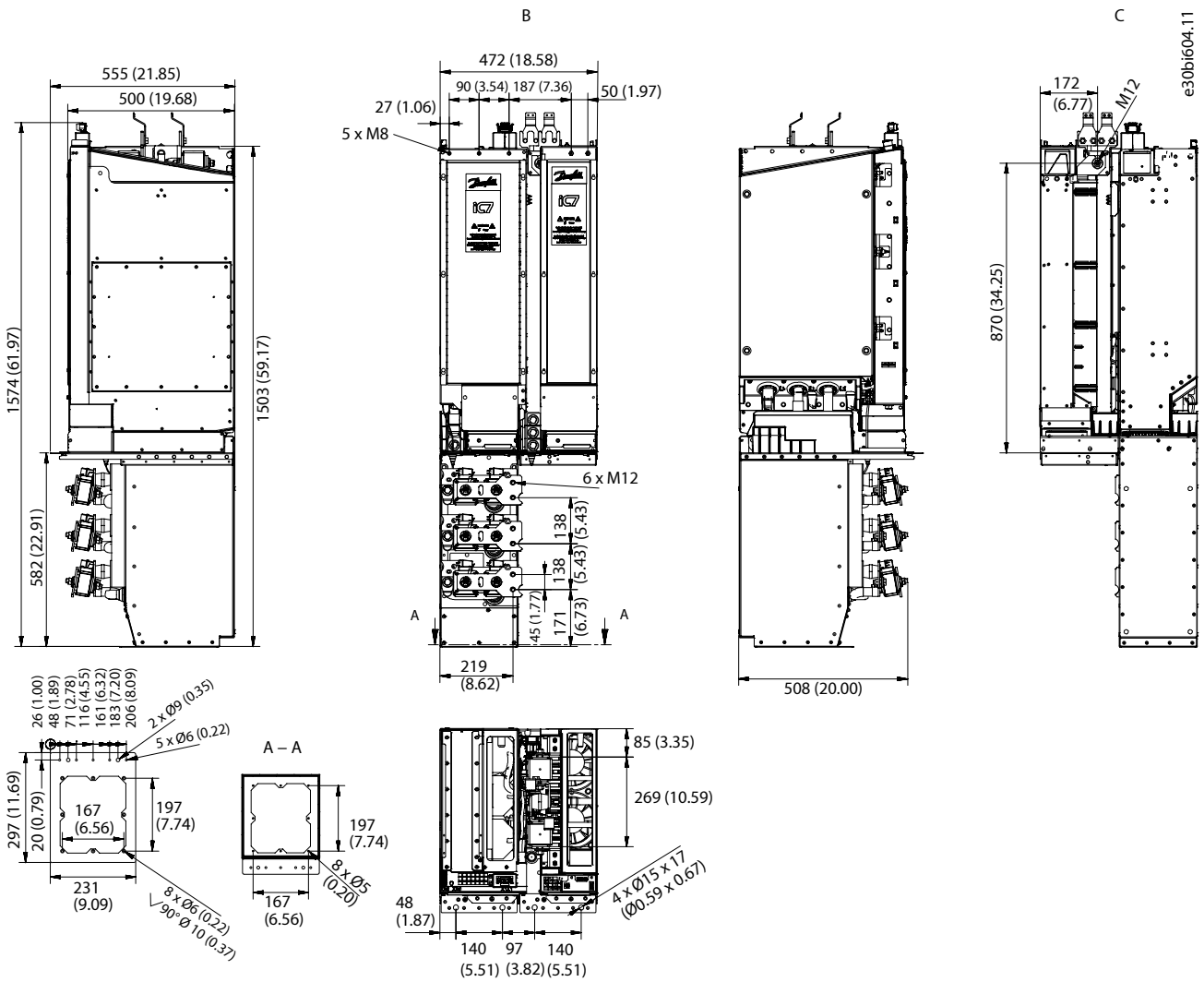

Figure 86: Dimensions of the LCL Filter, LCL10, and the AFE Module, AR10, with the Short Integration Unit (+AE01) in mm (in)

B	Front	C	Back
---	-------	---	------

10.2.14 Dimensions of the LCL Filter, LCL11, and the AFE Module, AR11, with the Short Integration Unit (+AE01)

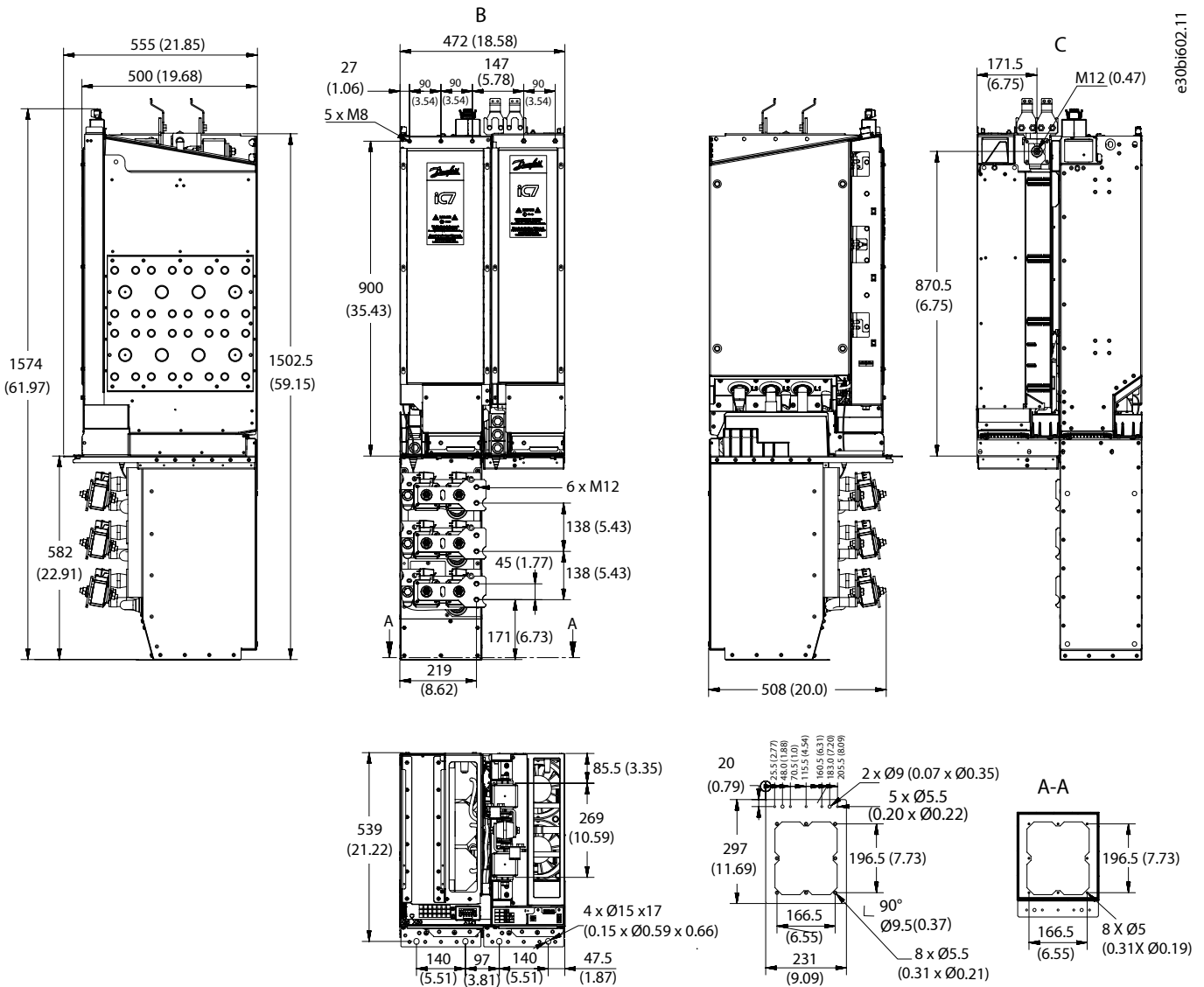

Figure 88: Dimensions of the LCL Filter, LCL11, and the AFE Module, AR11, with the Short Integration Unit (+AE01) in mm (in)

B	Front	C	Back
---	-------	---	------

10.2.16 Dimensions of the LCL Filter, LCL11W, and the AFE Module, AR11, with the Short Integration Unit (+AE01)

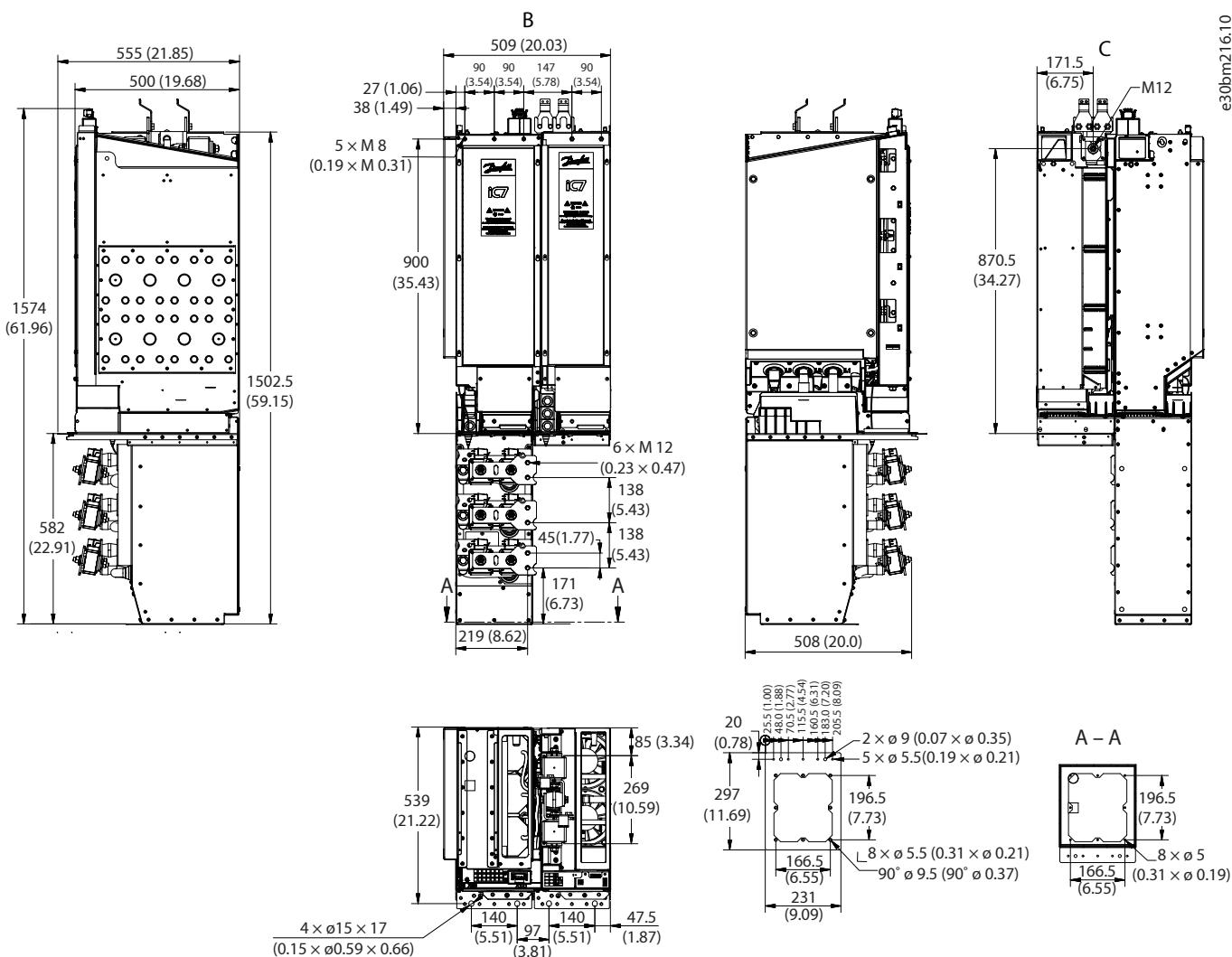
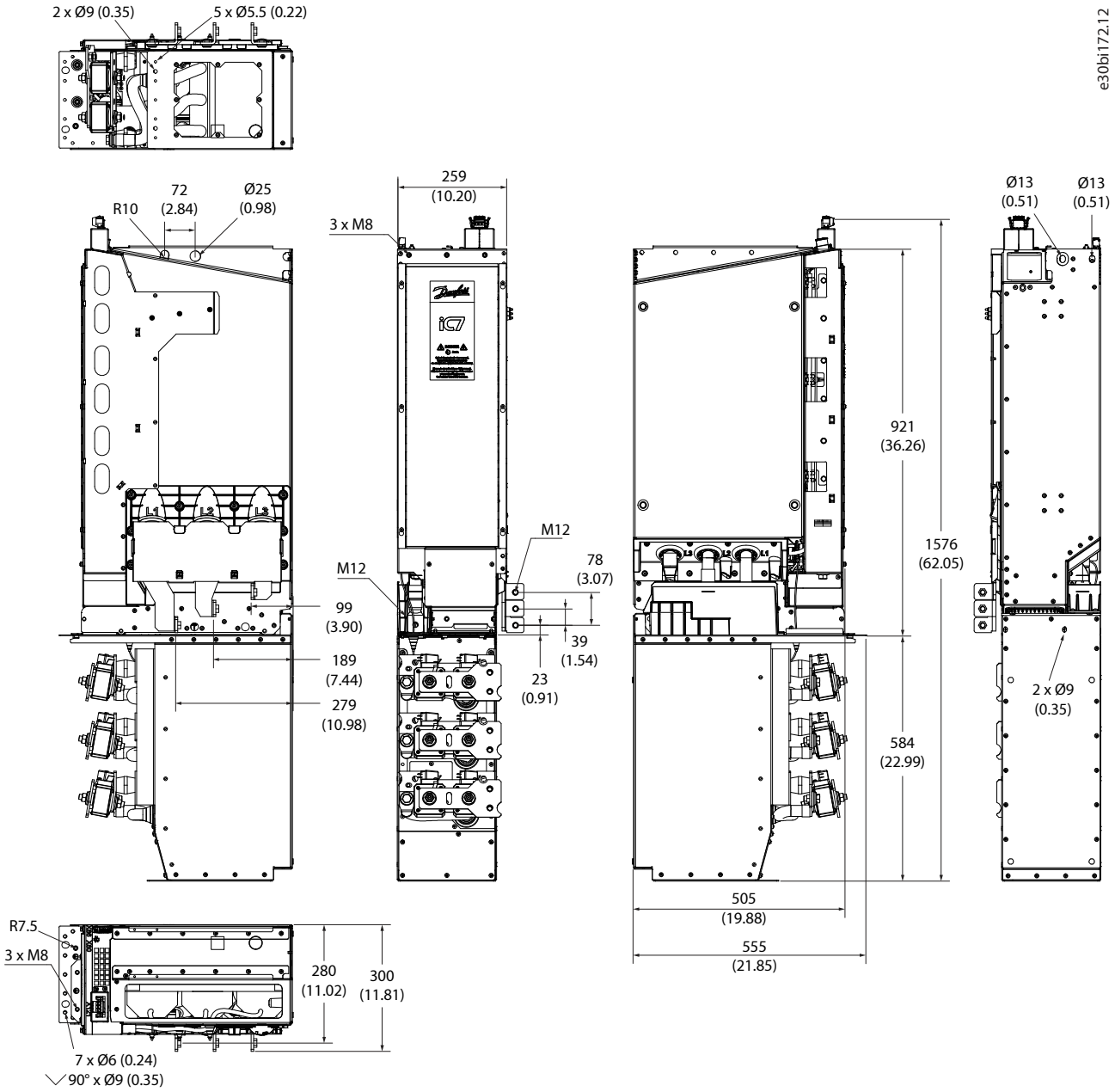

Figure 90: Dimensions of the LCL Filter, LCL11W, and the AFE Module, AR11, with the Short Integration Unit (+AE01) in mm (in)

B Front

C Back

10.2.17 Dimensions of the LCL Filter, LCL10 (514 A) and LCL11 (816 A)



e30bi172.12

Figure 91: Dimensions of the LCL Filter, LCL10 (514 A) and LCL11 (816 A) in mm (in)

10.2.18 Dimensions of the LCL Filter, LCL11W (820 A)

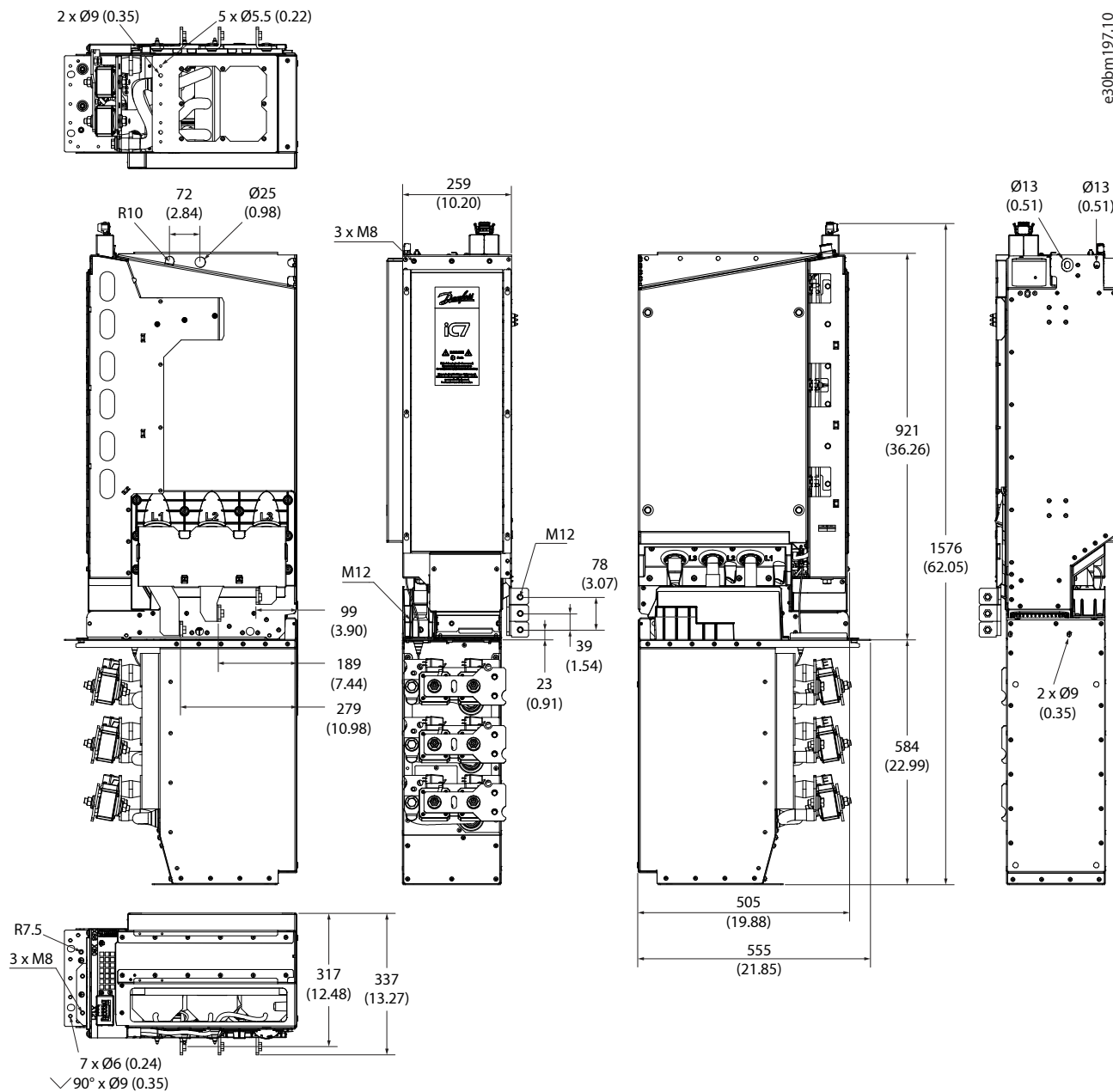

e30bm197.10

Figure 92: Dimensions of the LCL Filter, LCL11W (820 A) in mm (in)

10.2.19 Dimensions of the Short Integration Unit for AFE Module (+AE01)

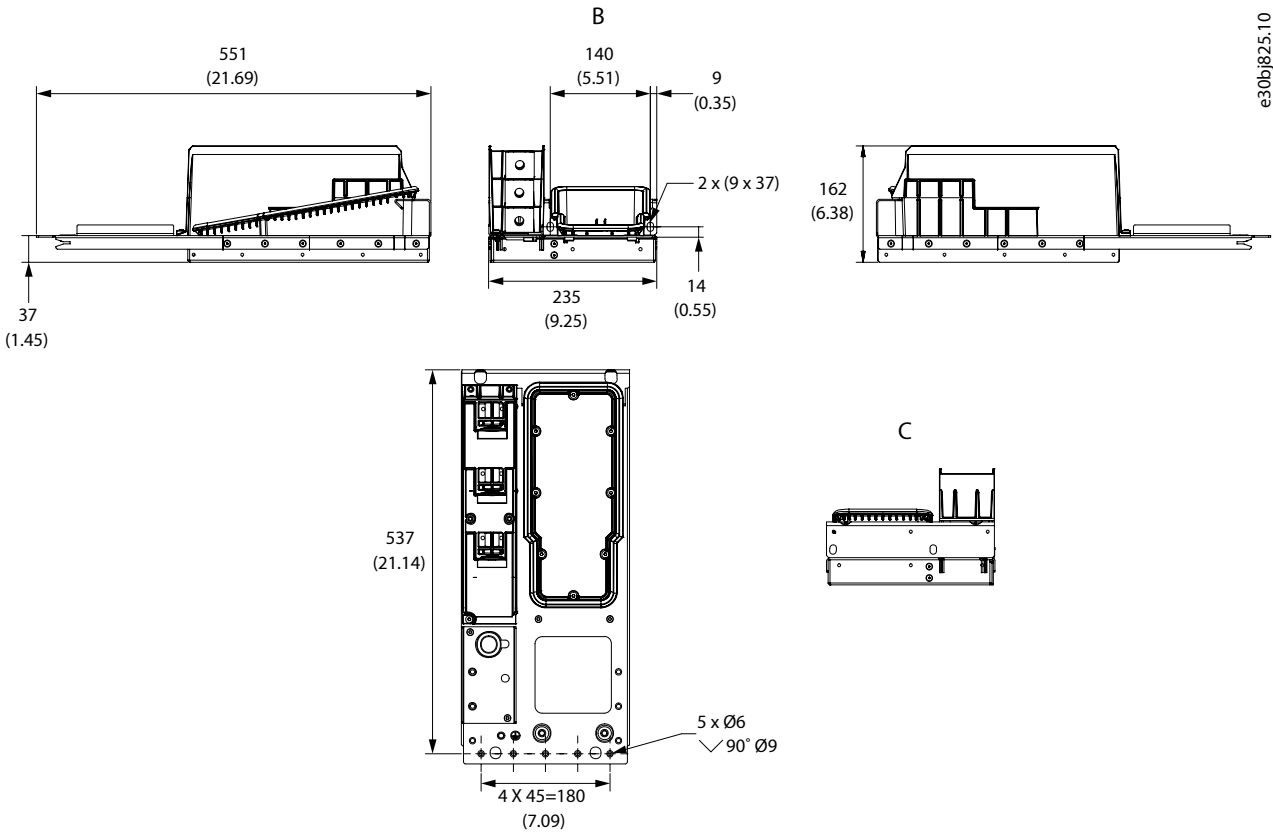

Figure 93: Dimensions of the Short Integration Unit for AFE Module (+AE01) in mm (in)

B	Front	C	Back
---	-------	---	------

10.2.20 Dimensions of the Standard Integration Unit for AFE Module (+AE10)

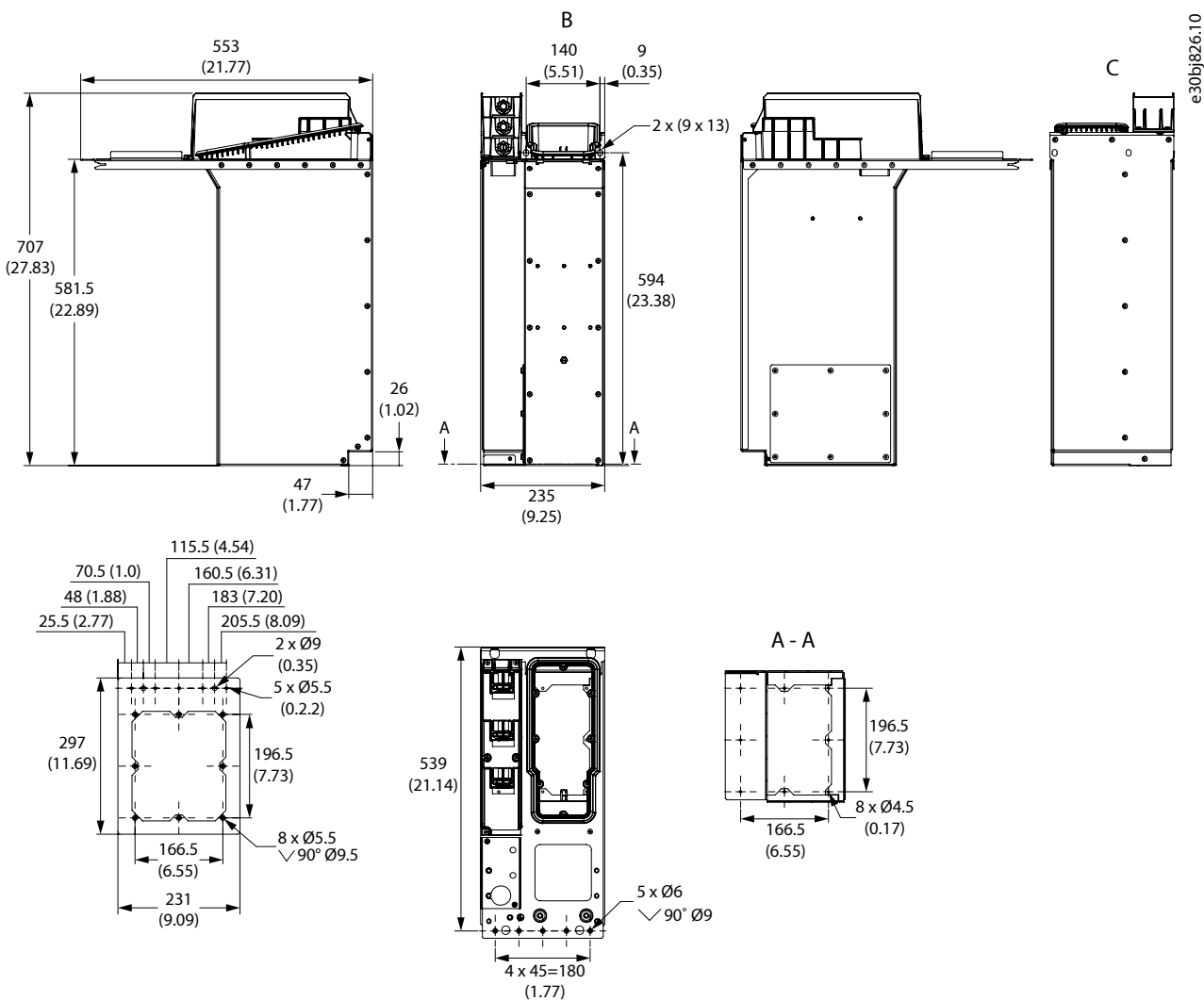

Figure 94: Dimensions of the Standard Integration Unit for AFE Module (+AE10) in mm (in)

B Front

C Back

10.2.21 Dimensions of the Short Integration Unit for Inverter Module (+AE01)

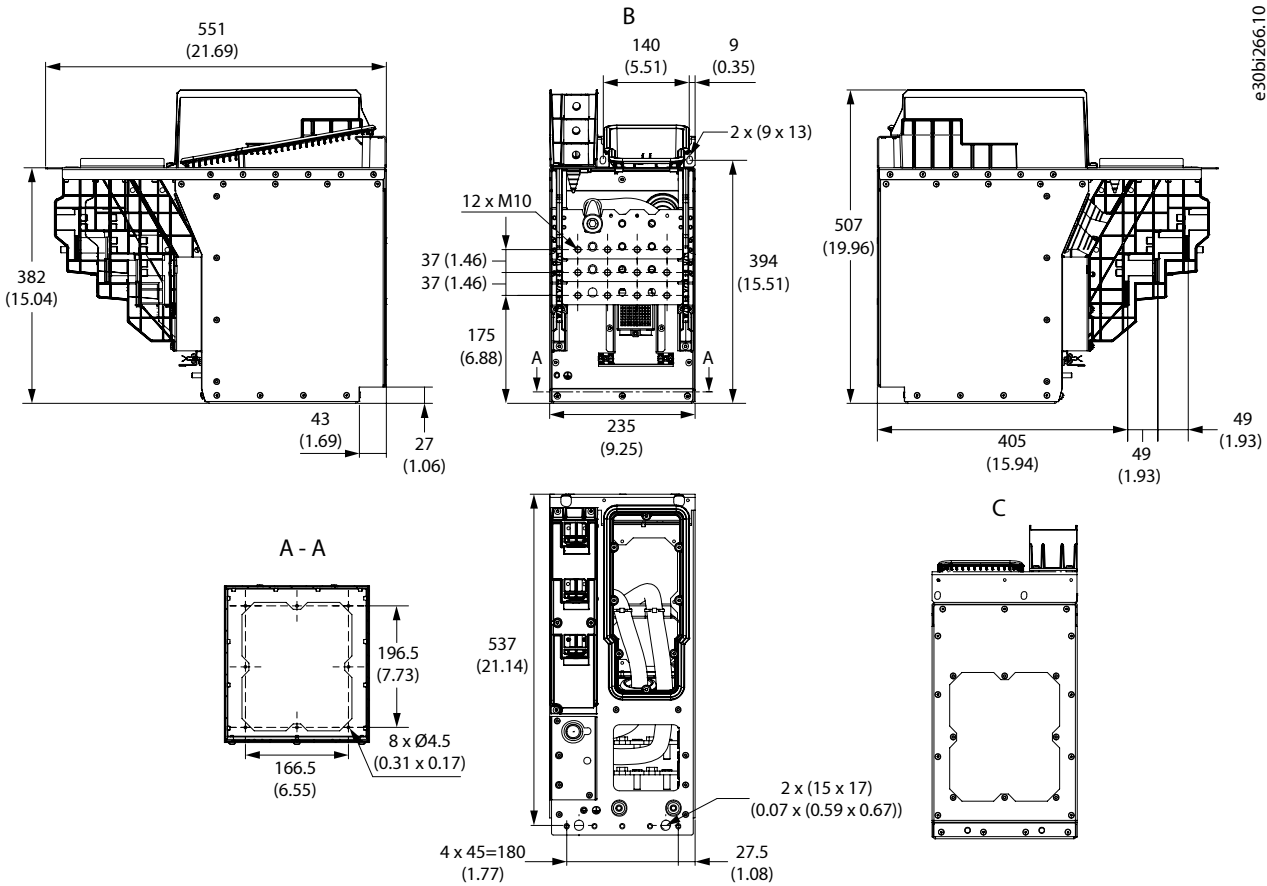
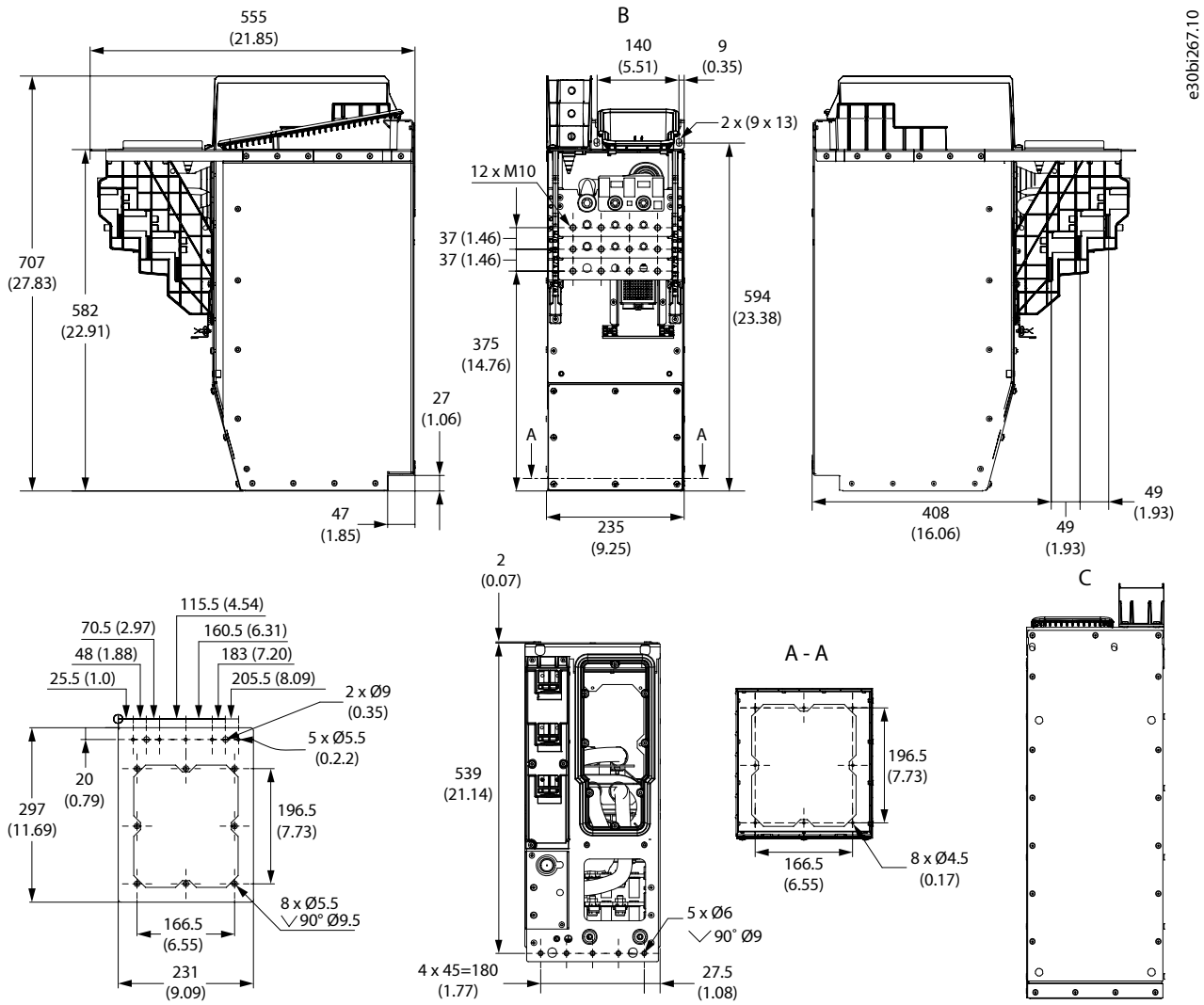

Figure 95: Dimensions of the Short Integration Unit for Inverter Module (+AE01) in mm (in)

B Front	C Back
------------	-----------

10.2.22 Dimensions of the Standard Integration Unit for Inverter Module (+AE10)



e30bi267.10

Figure 96: Dimensions of the Standard Integration Unit for Inverter Module (+AE10) in mm (in)

B	C
Front	Back

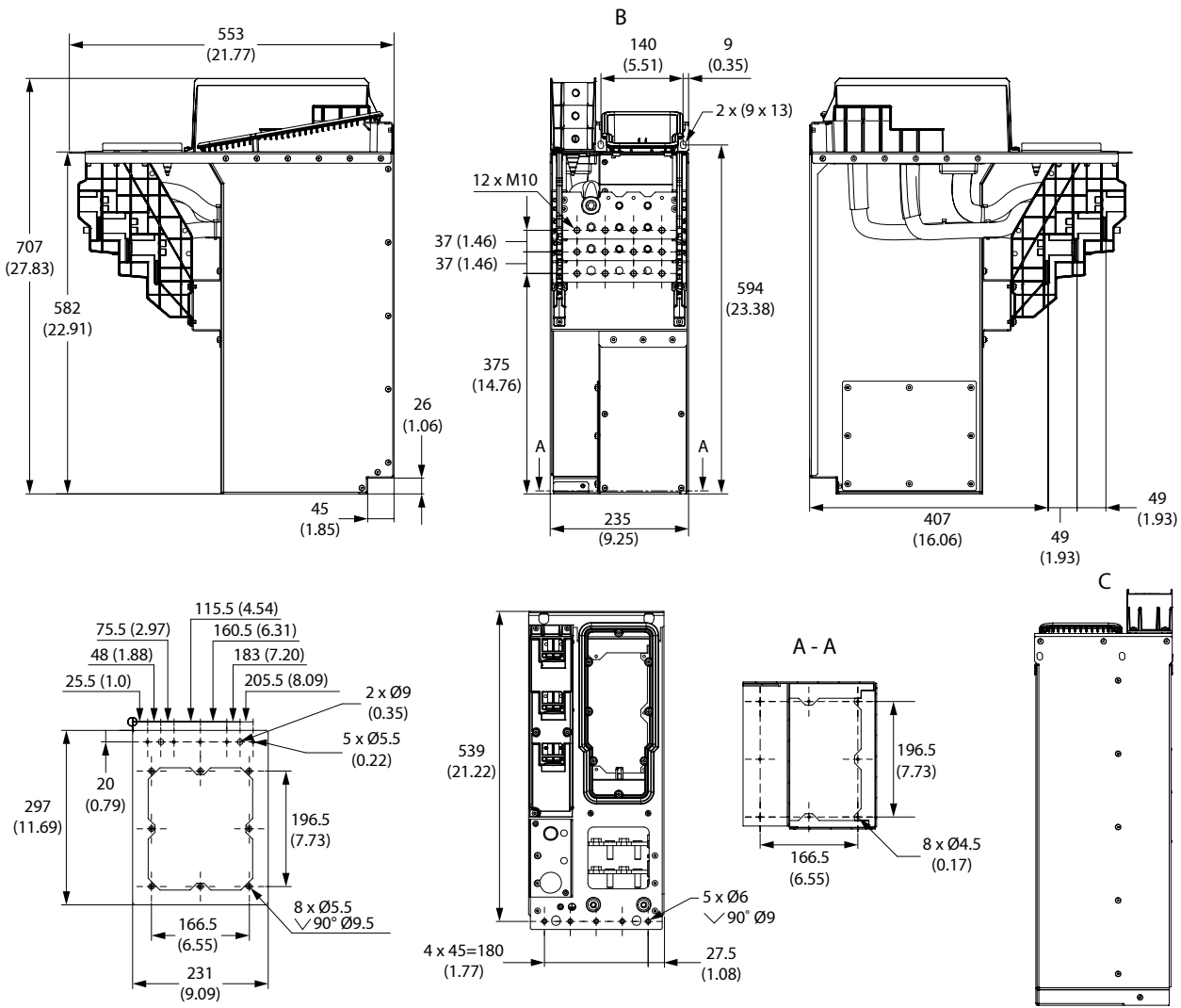

e30bi601.10

Figure 97: Dimensions of the Empty Standard Integration Unit for Inverter Module in mm (in)

B	Front	C	Back
---	-------	---	------

10.2.23 Dimensions for DC Fuses, IM10

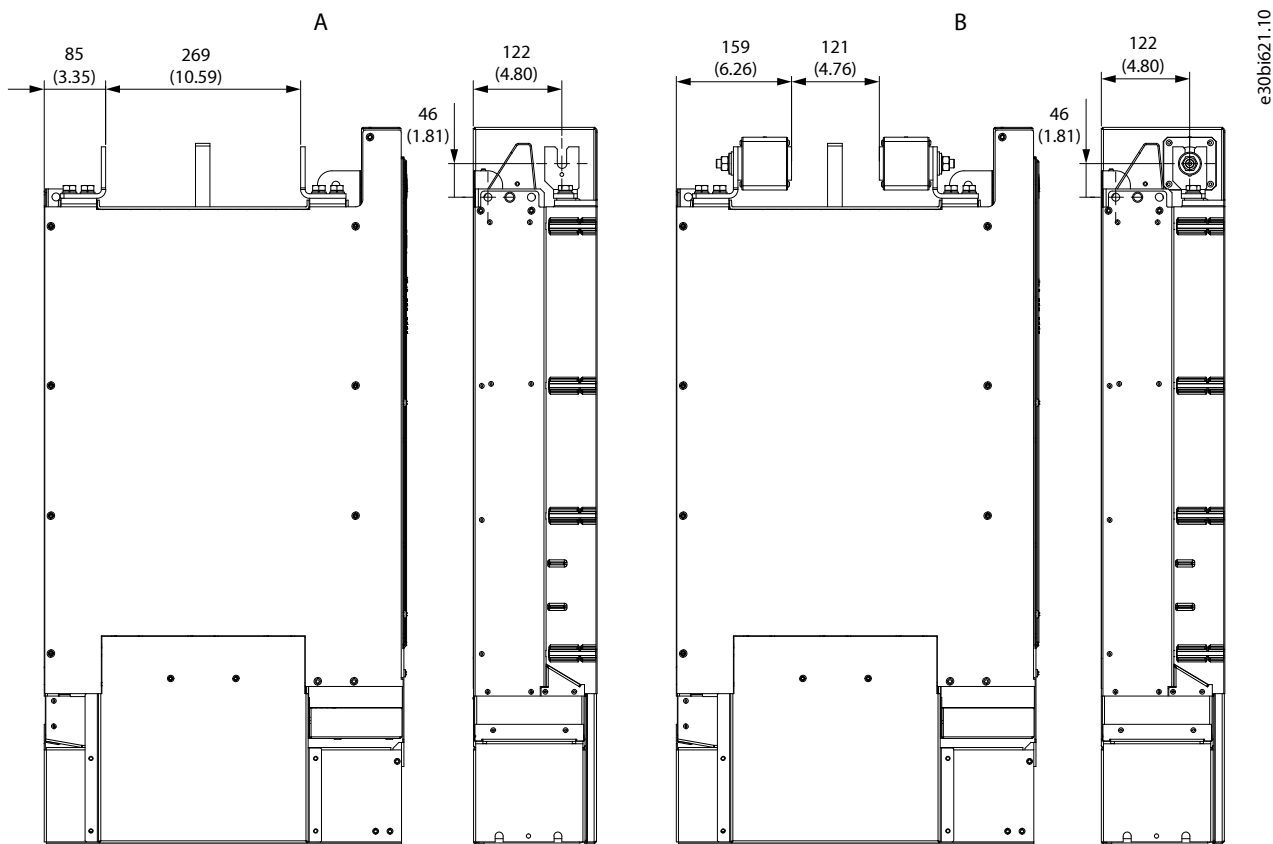
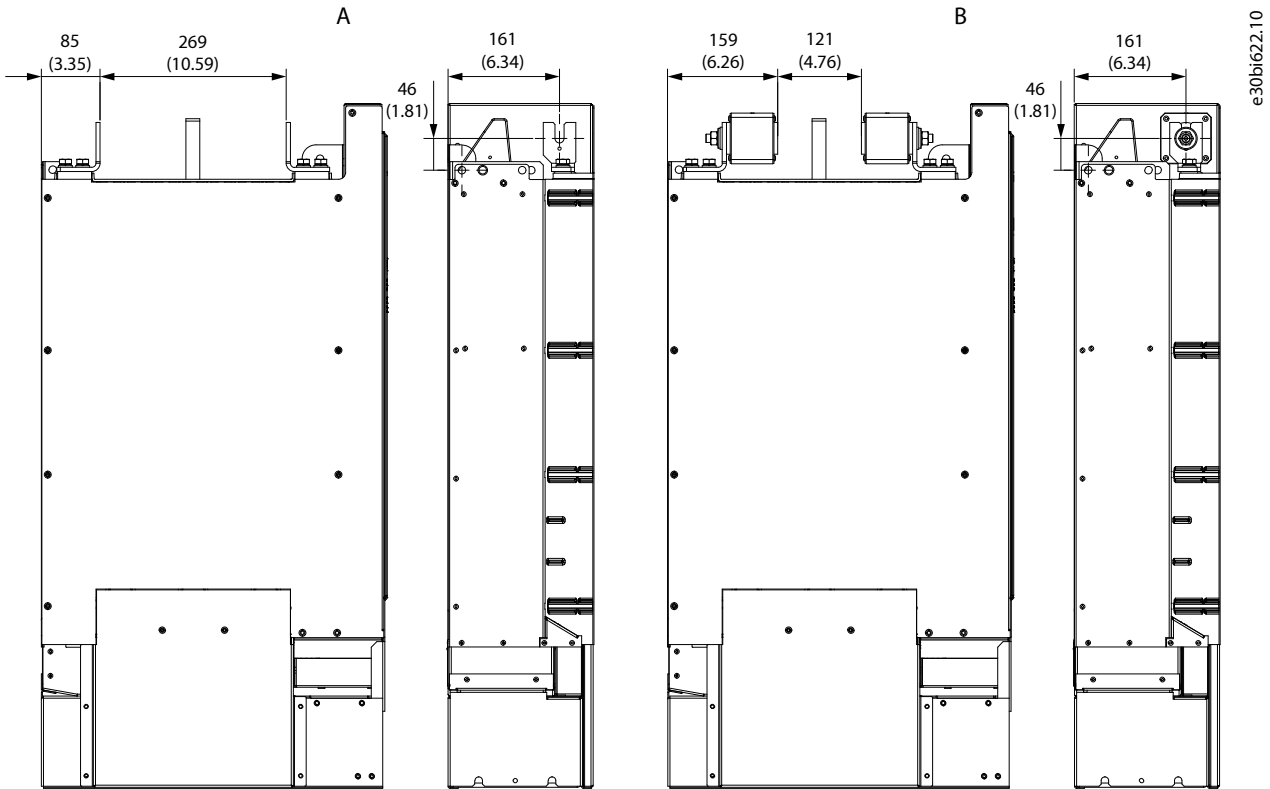

Figure 98: Dimensions for DC Fuses, IM10, in mm (in)

A Dimensions without DC fuses

B Dimensions with DC fuses

10.2.24 Dimensions for DC Fuses, IM11



e:30bi622.10

Figure 99: Dimensions for DC Fuses, IM11, in mm (in)

A	B
Dimensions without DC fuses	Dimensions with DC fuses

10.2.25 Dimensions for DC Fuses, IR10

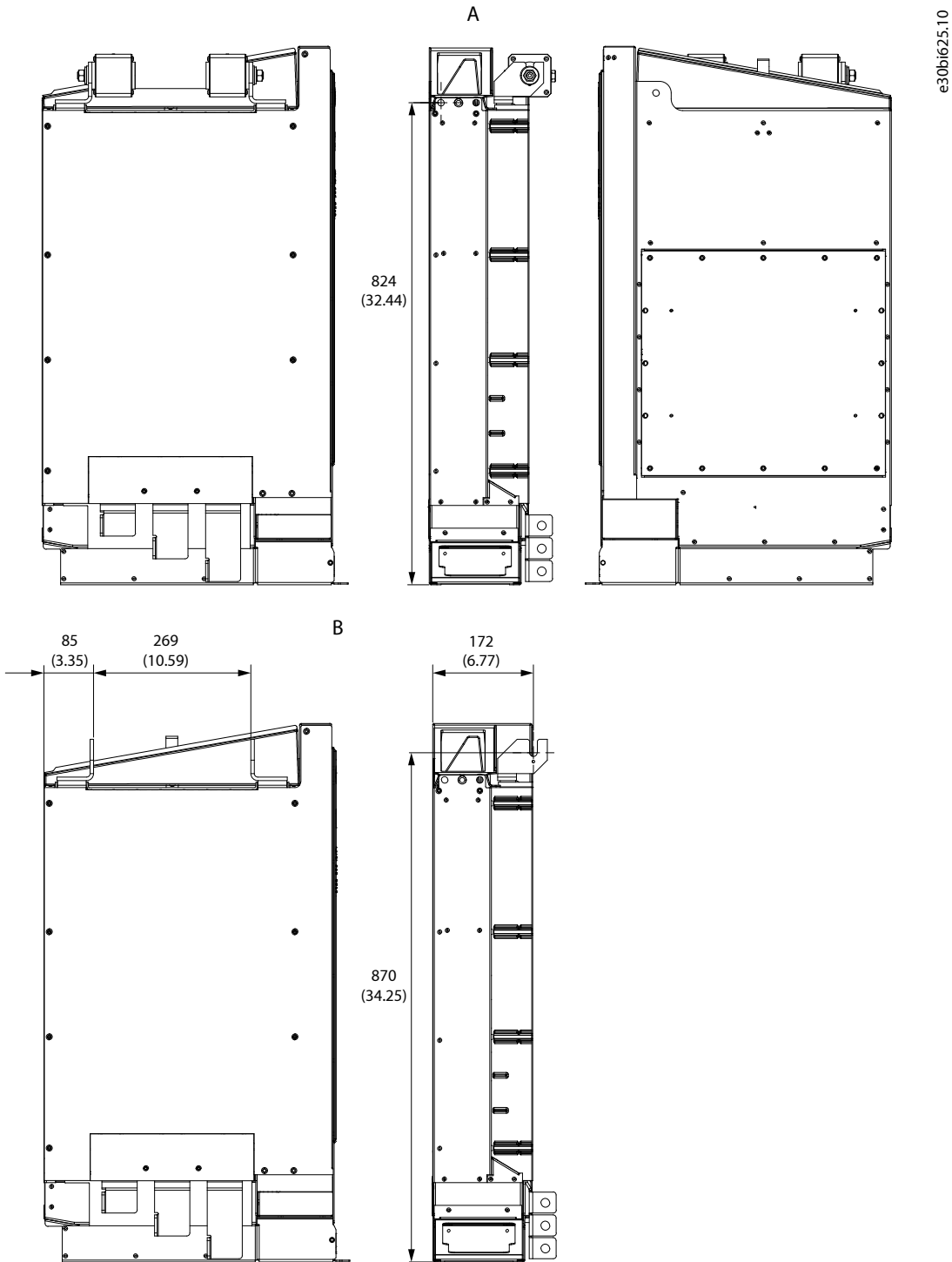

Figure 100: Dimensions for DC Fuses, IR10, in mm (in)

A Dimensions with DC fuses

B Dimensions without DC fuses

10.2.26 Dimensions for DC Fuses, IR11

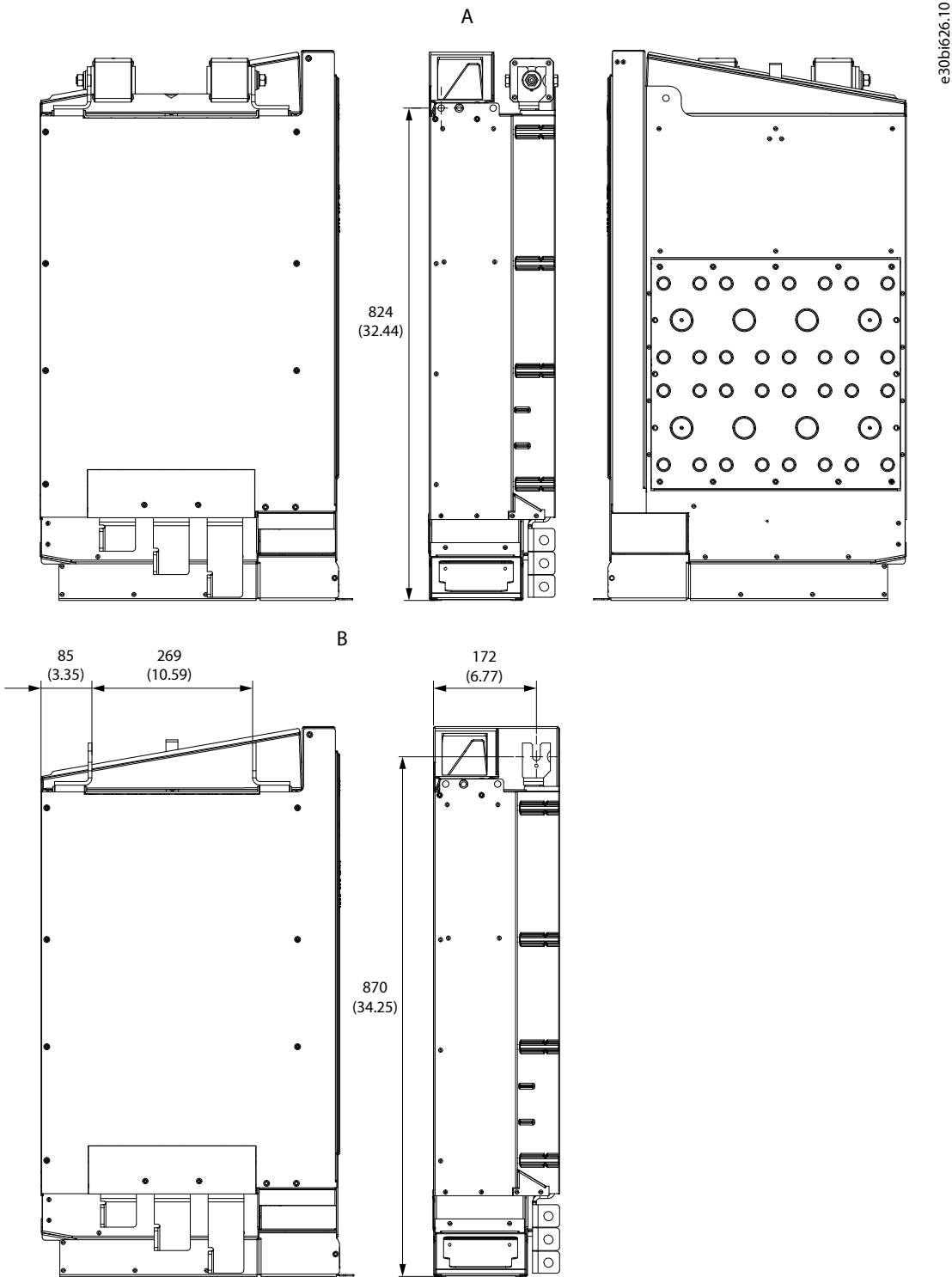

Figure 101: Dimensions for DC Fuses, IR11, in mm (in)

A	Dimensions with DC fuses	B	Dimensions without DC fuses
---	--------------------------	---	-----------------------------

10.2.27 Dimensions of the Control Unit

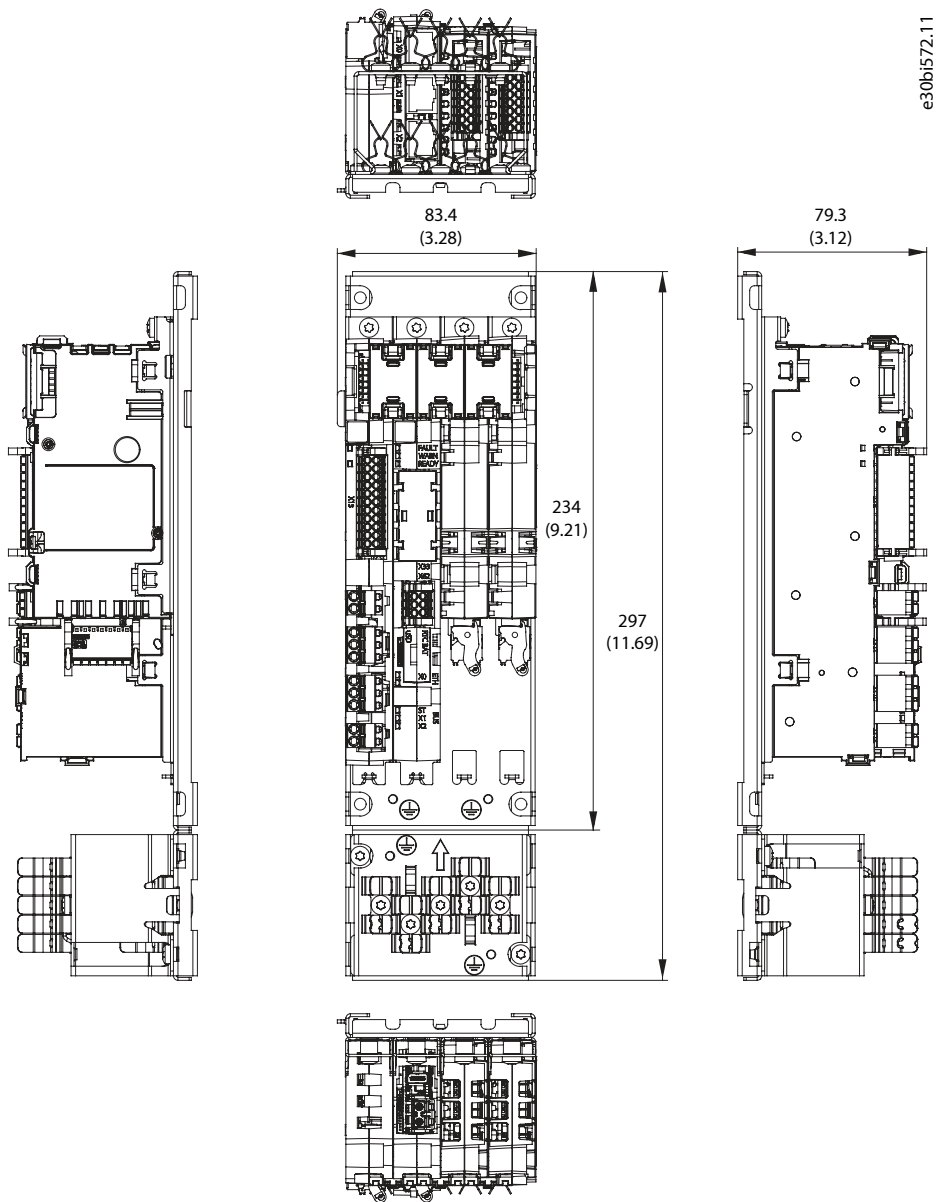

Figure 102: Dimensions of the Control Unit in mm (in), Example Configuration

10.2.28 Dimensions of the Control Unit Mounting Plate

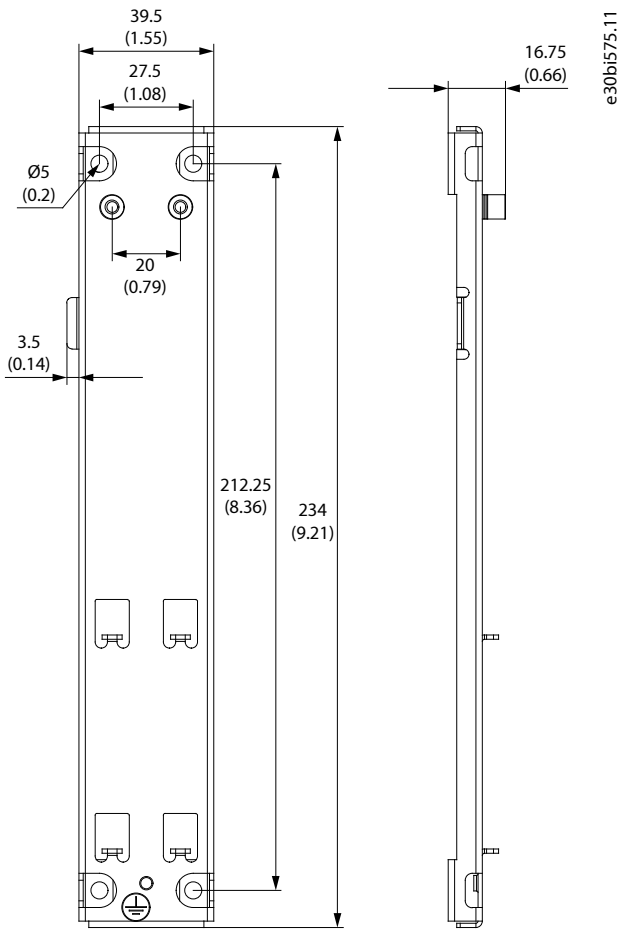
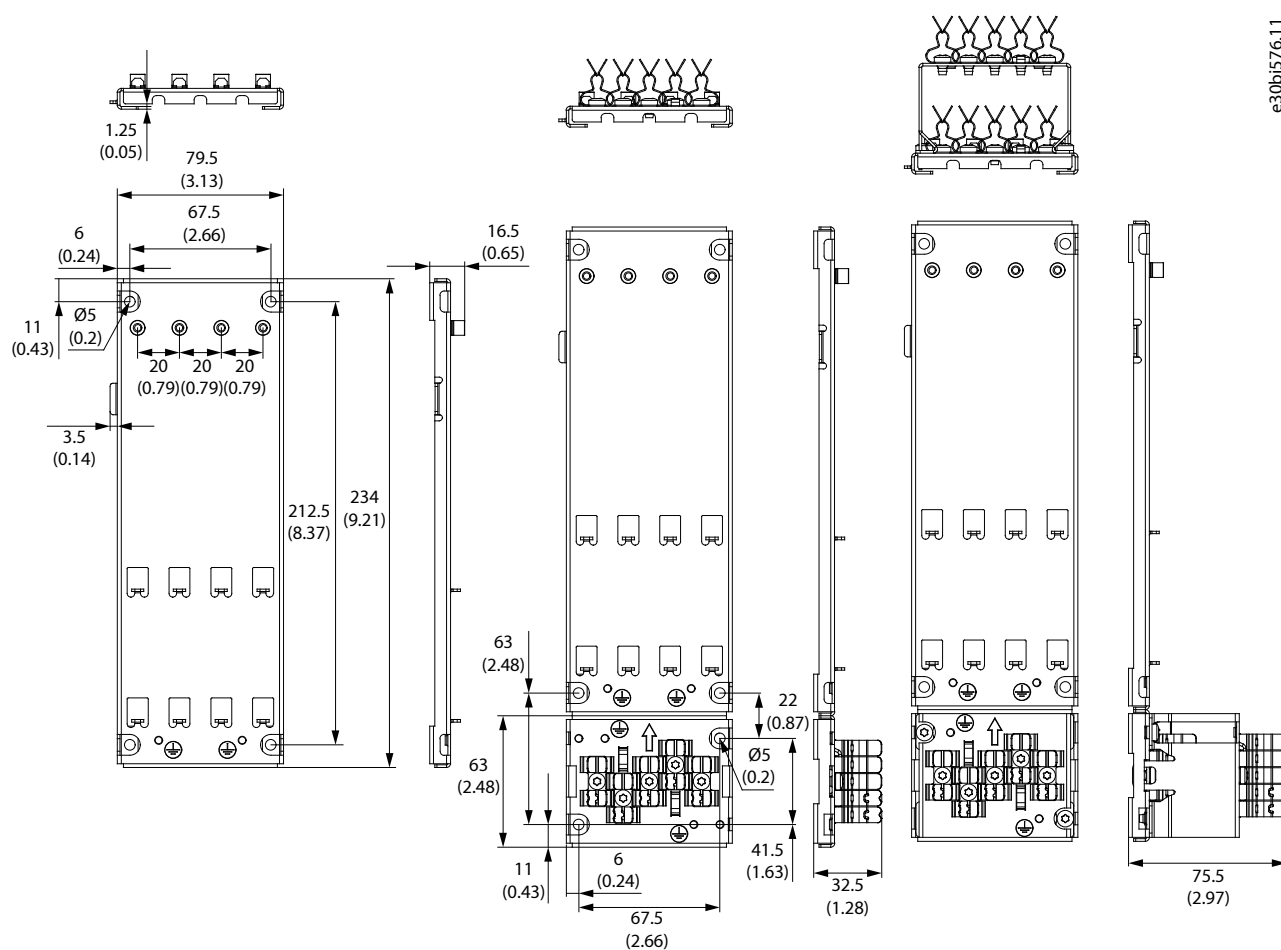

Figure 103: Dimensions of the Modular Control Unit Mounting Plate in mm (in), 2 Places



e30bi576.11

Figure 104: Dimensions of the Modular Control Unit Mounting Plate in mm (in), 4 Places

10.2.29 Dimensions of the Option Connector

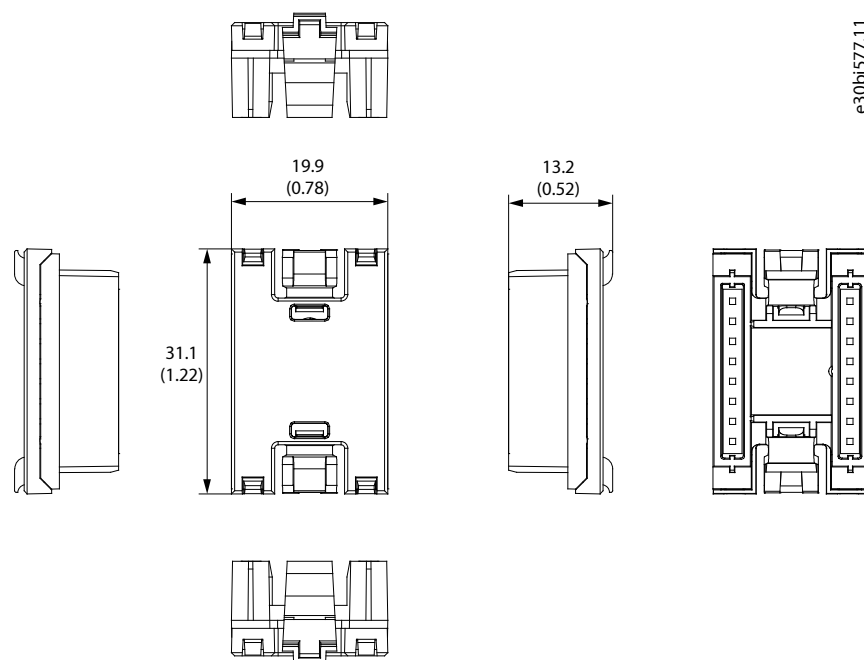

e30bi577.11

Figure 105: Dimensions of the Option Connector in mm (in)

10.2.30 Dimensions of the Control Board

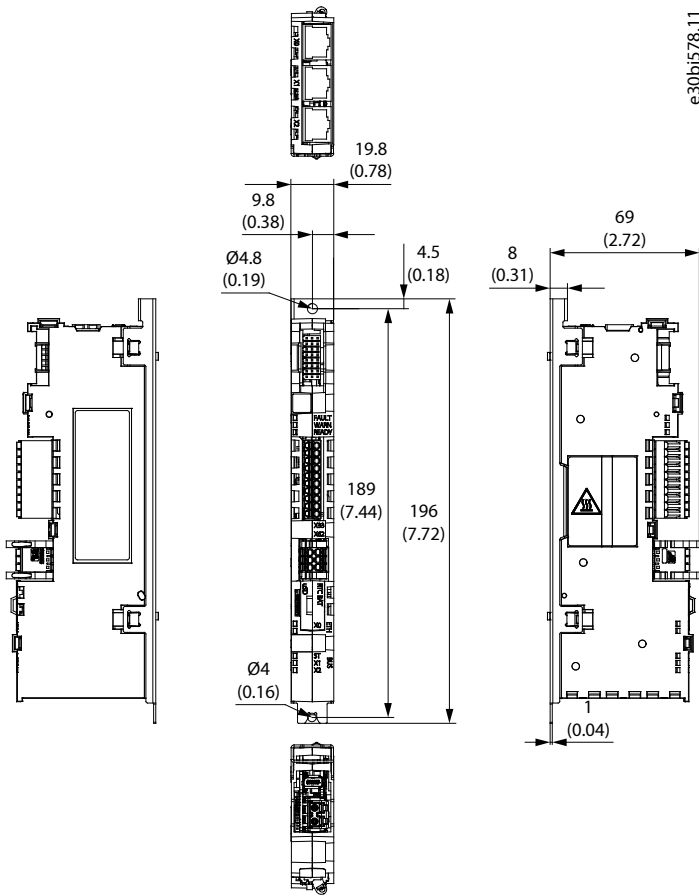

Figure 106: Dimensions of the Control Board in mm (in)

10.2.31 Dimensions of the I/O and Relay Option

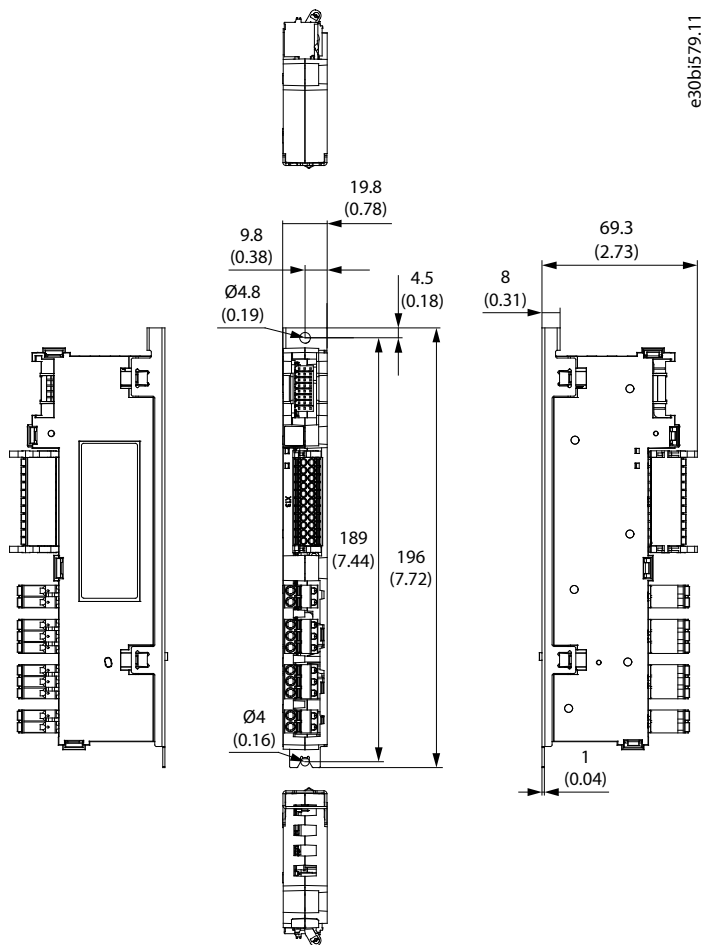

Figure 107: Dimensions of the I/O and Relay Option in mm (in)

10.2.32 Dimensions of an Option Board

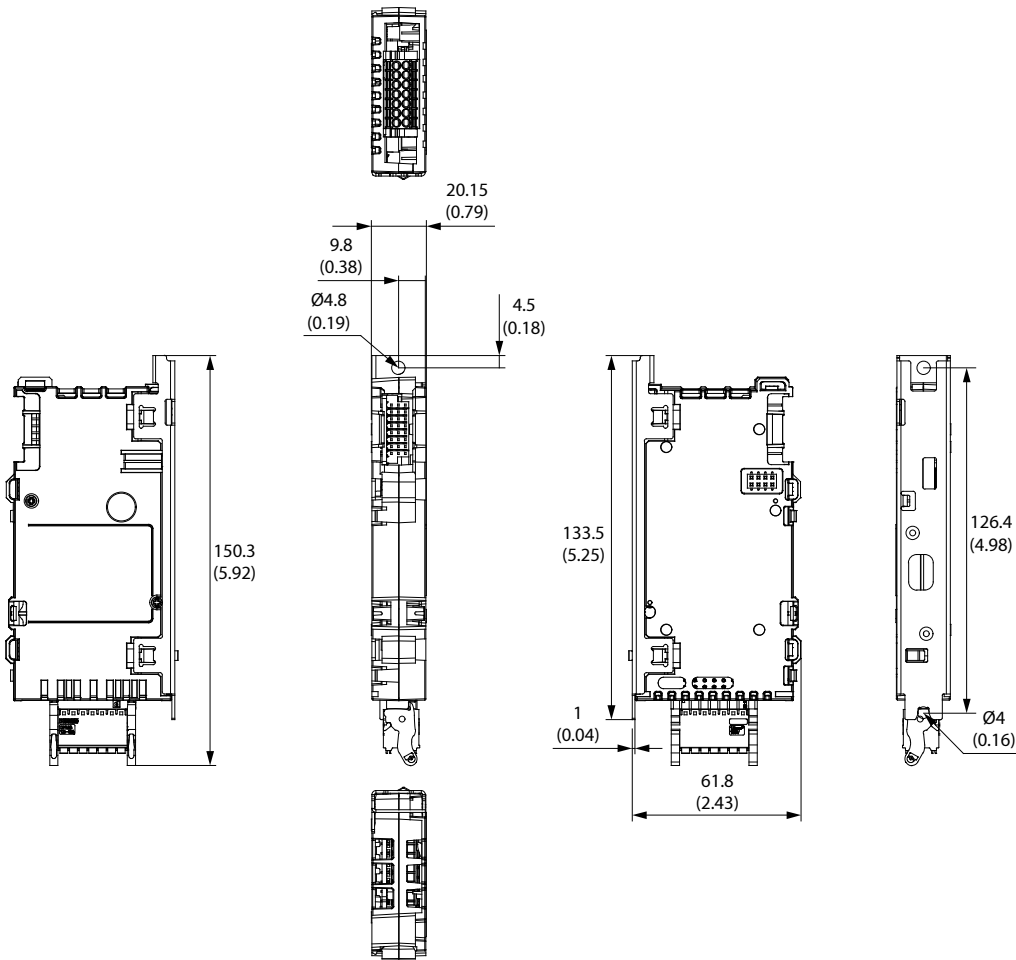
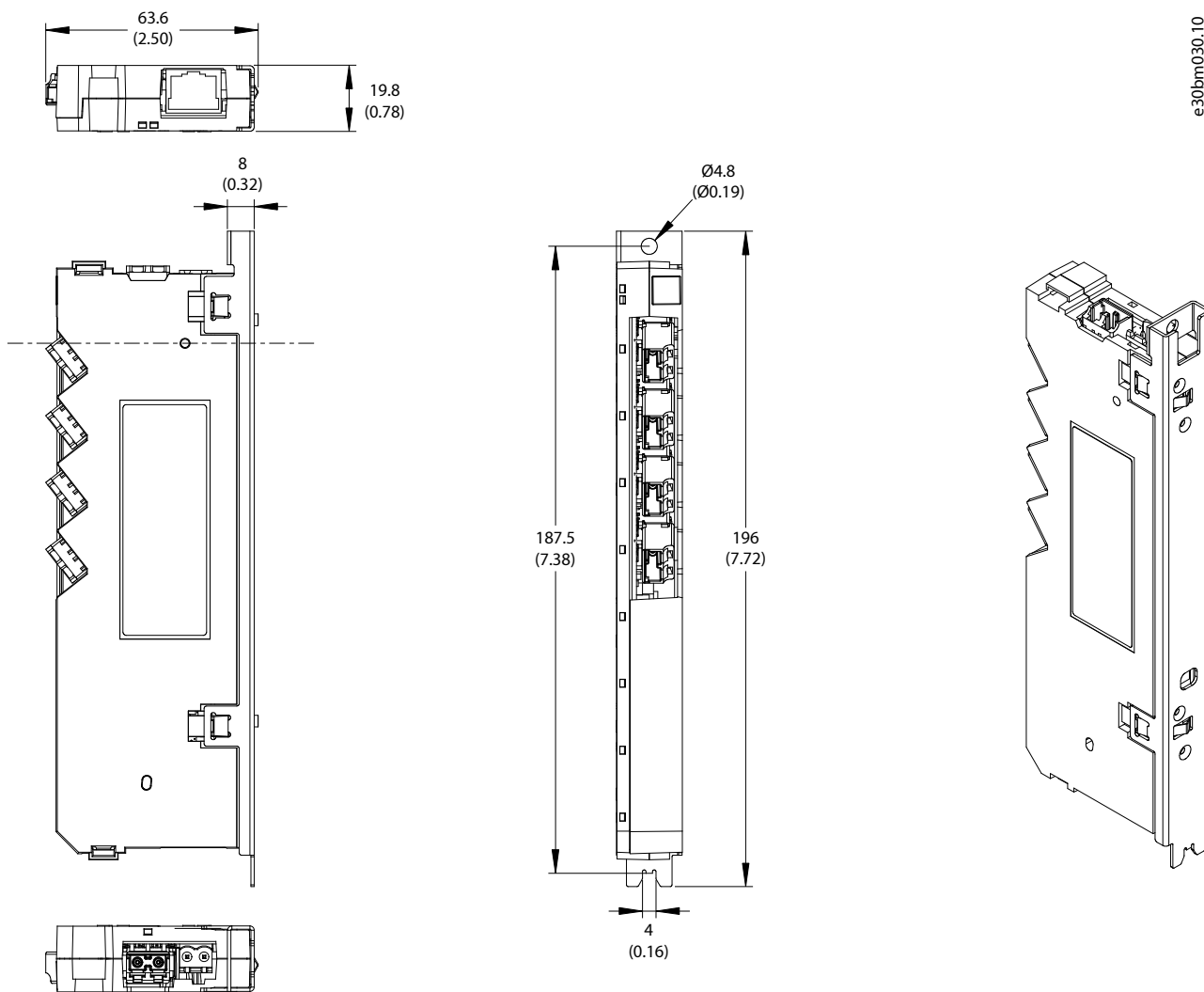

Figure 108: Dimensions of an Option Board in mm (in)

10.2.33 Dimensions of the 4-port Star Coupler Board



e30bm030.10

Figure 109: Dimensions of the 4-port Star Coupler Board in mm (in)

10.2.34 Dimensions of the 8-port Star Coupler Board

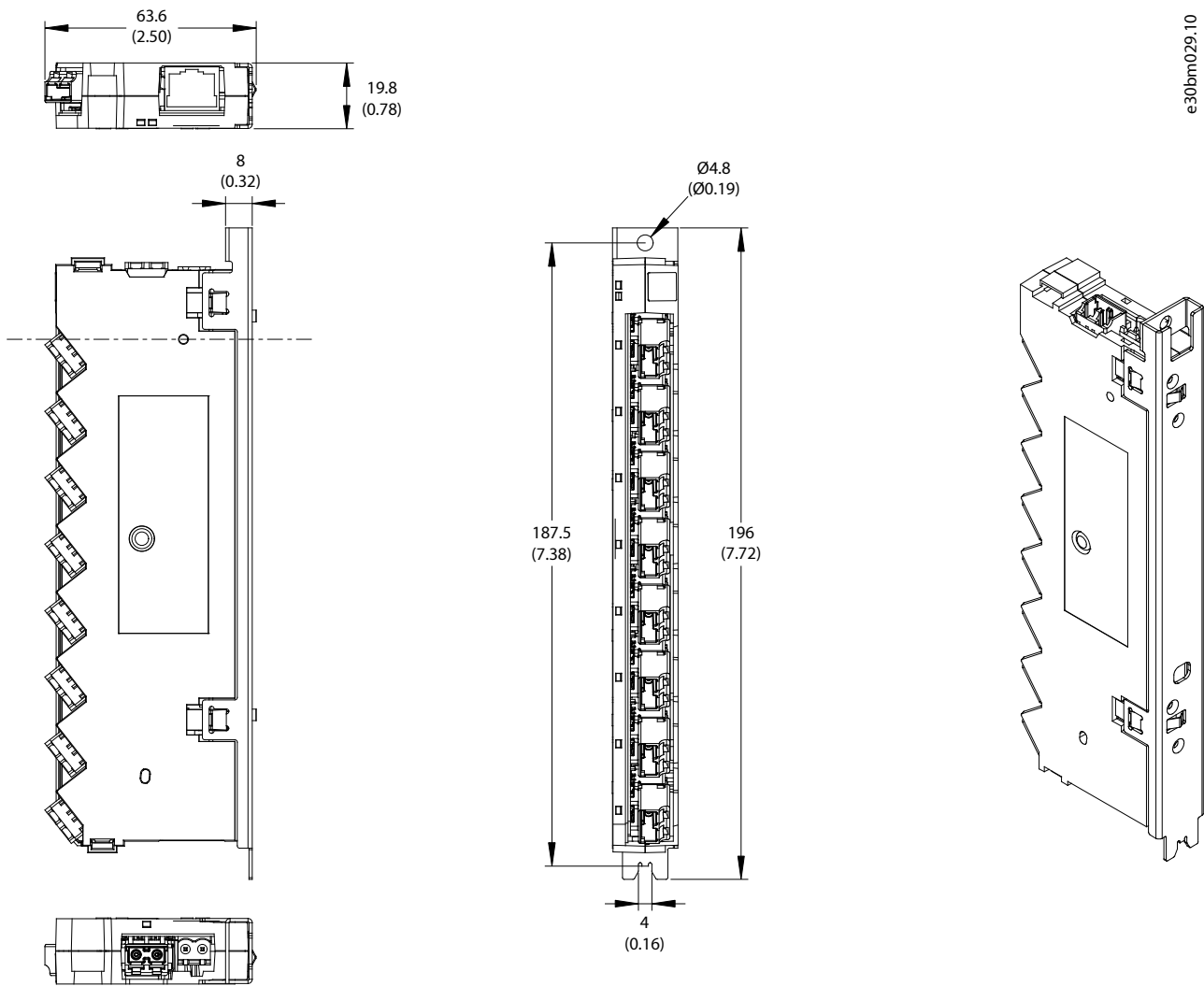

e30bm029,10

Figure 110: Dimensions of the 8-port Star Coupler Board in mm (in)

10.2.35 Dimensions of the 16-port Star Coupler Board

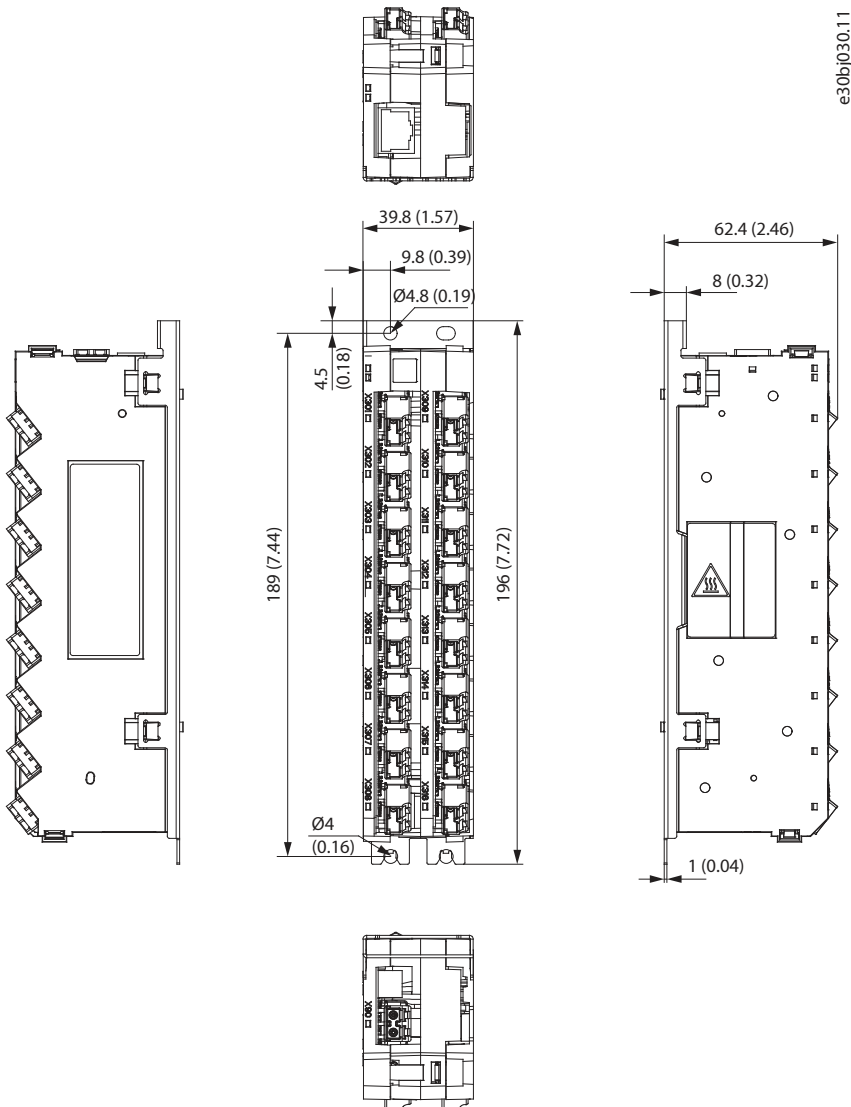
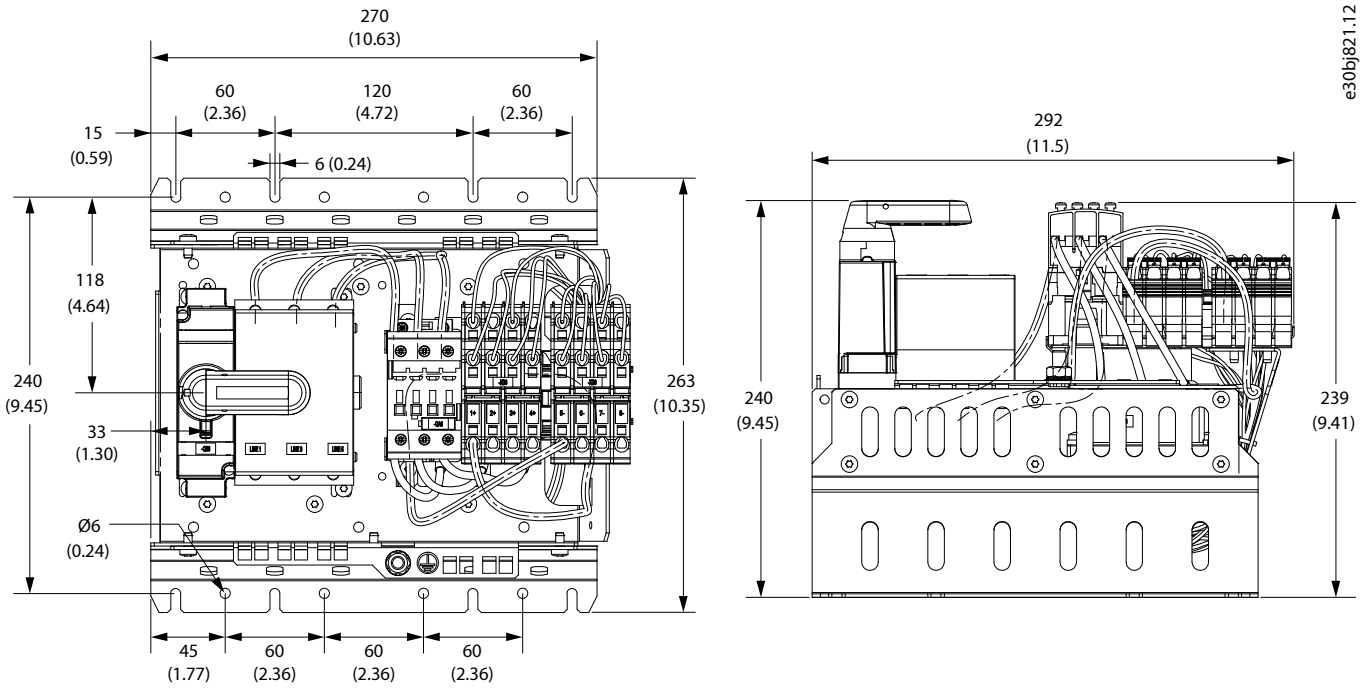

Figure 111: Dimensions of the 16-port Star Coupler Board in mm (in)

10.2.36 Dimensions of the Pre-charging Unit, IEC



e30bj821.12

Figure 112: Dimensions of the Pre-charging Unit in mm (in), IEC

10.2.37 Dimensions of the Pre-charging Unit, UL

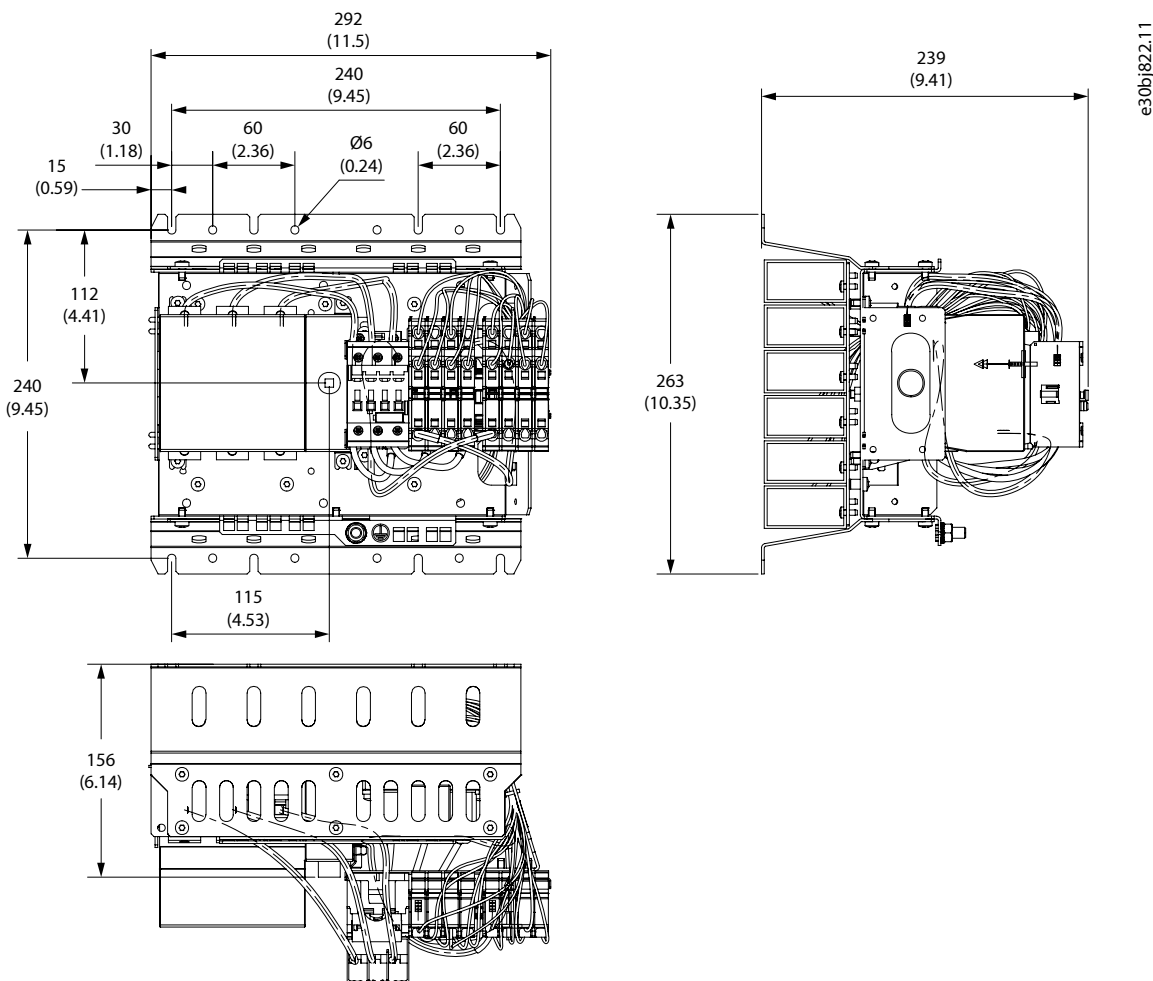

e30bj822.11

Figure 113: Dimensions of the Pre-charging Unit in mm (in), UL

10.3 Wiring Diagrams

10.3.1 Wiring Diagram, AFE Modules

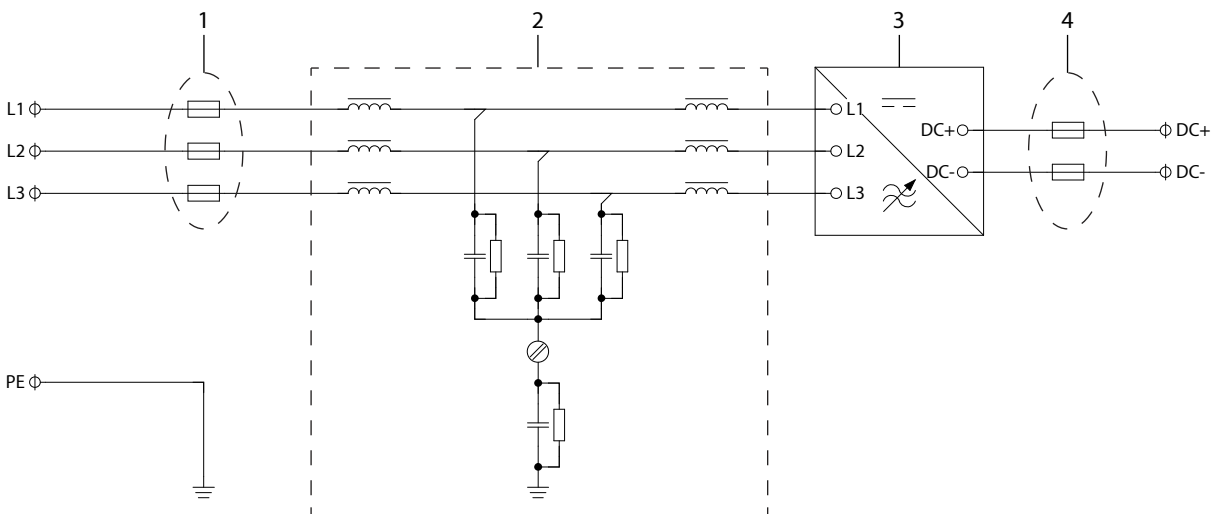

e30bh862.11

Figure 114: Wiring Diagram, AFE Modules

1	AC fuses	2	LCL Filter
3	AFE module	4	DC fuses

10.3.2 Wiring Diagram, AFE Modules with Parallel Power Units

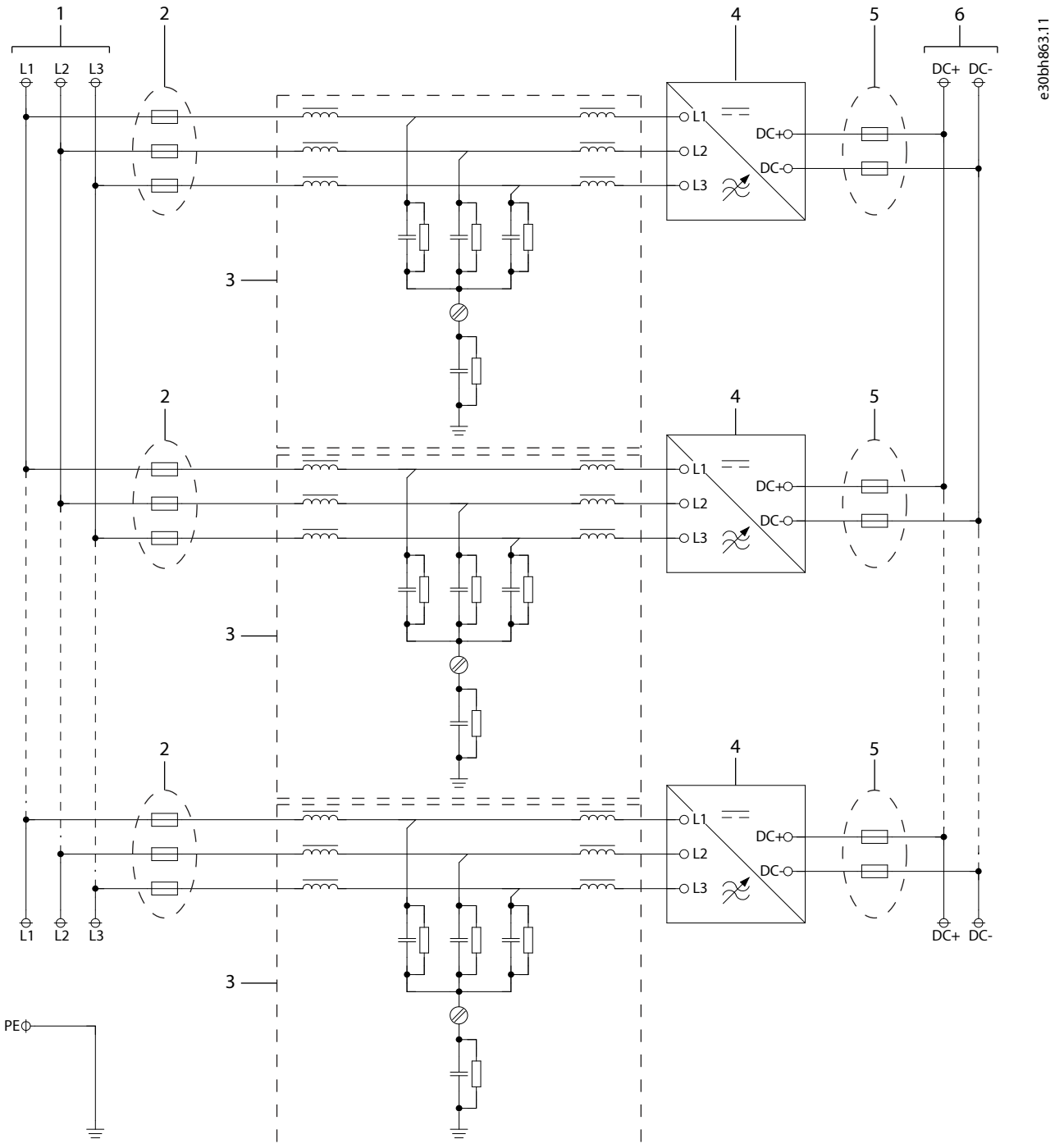
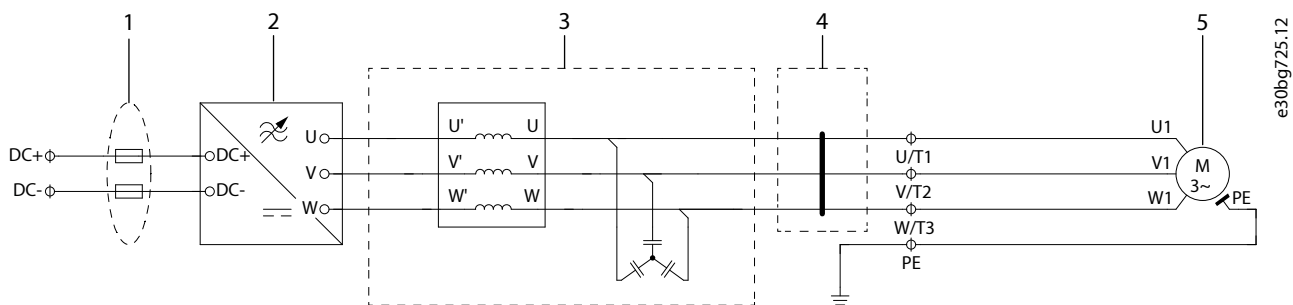

Figure 115: Wiring Diagram, AFE Modules with Parallel Power Units

1	Common AC bus	2	AC fuses
3	LCL Filters	4	AFE modules
5	DC fuses	6	Common DC bus

10.3.3 Wiring Diagram, Inverter Modules



e30bg725.12

Figure 116: Wiring Diagram, Inverter and dU/dt Filter

1	DC fuses	2	Inverter module
3	dU/dt Filter	4	Common-mode Filter
5	Motor		

10.3.4 Wiring Diagram, Inverter Modules with Parallel Power Units

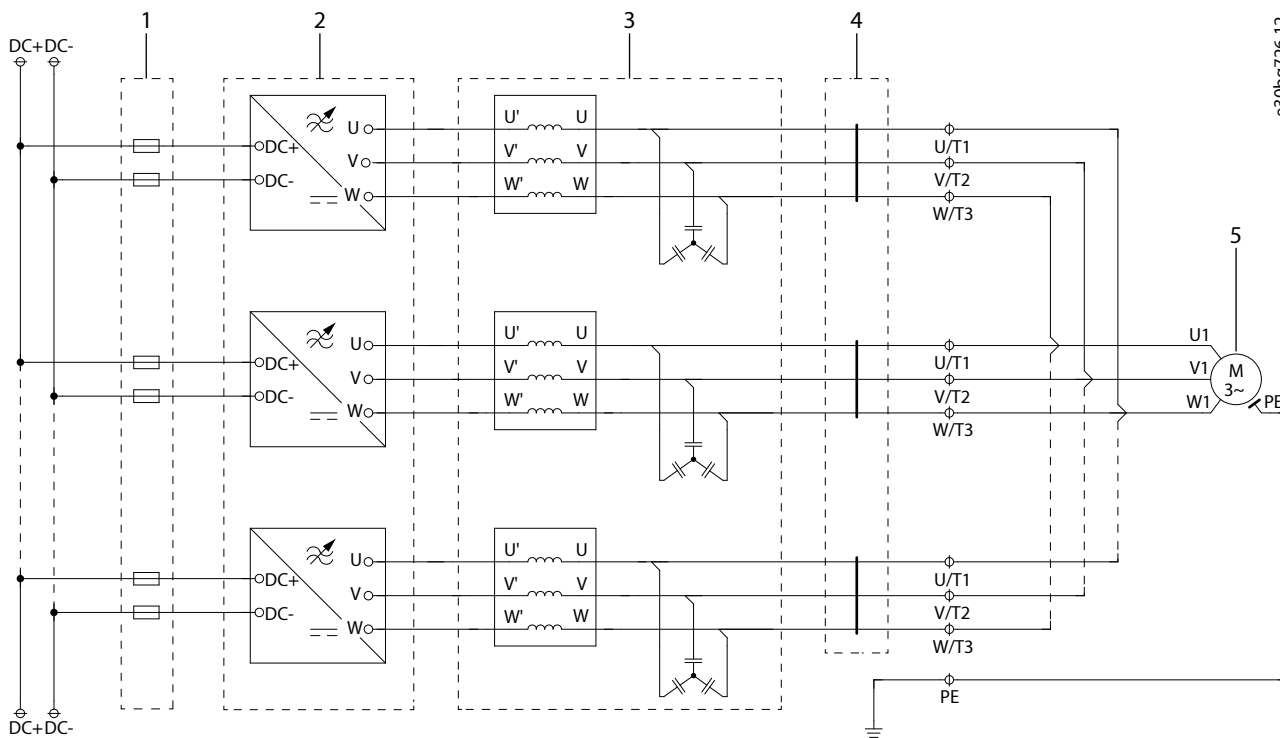

e30bg726.12

Figure 117: Wiring Diagram, Inverter and dU/dt Filter with Parallel Power Units, with a Common DC Bus

1	DC fuses	2	Inverter modules
3	dU/dt Filters	4	Common-mode Filters
5	Motor		

10.3.5 Pre-charging Wiring Diagram, AFE Modules

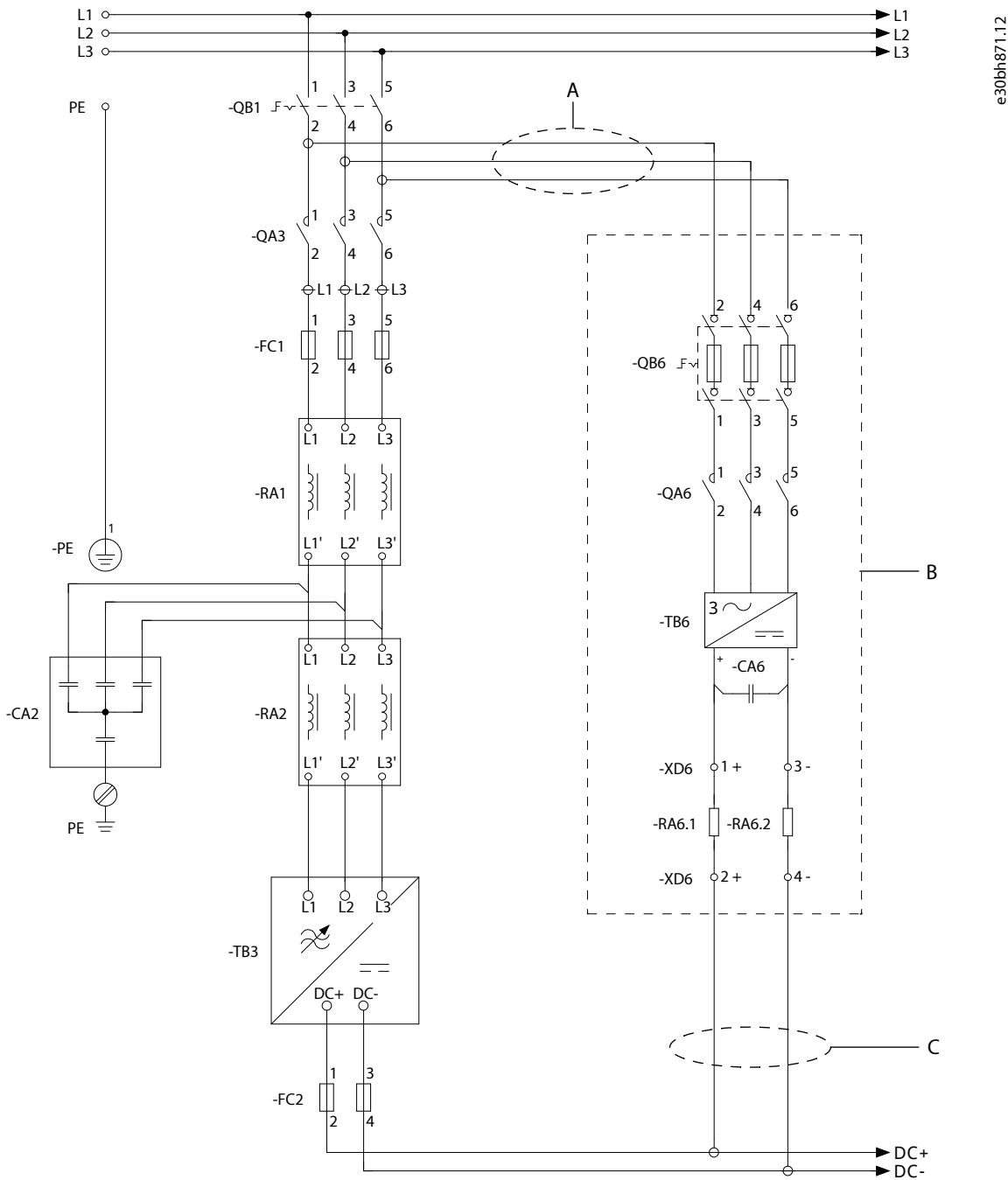
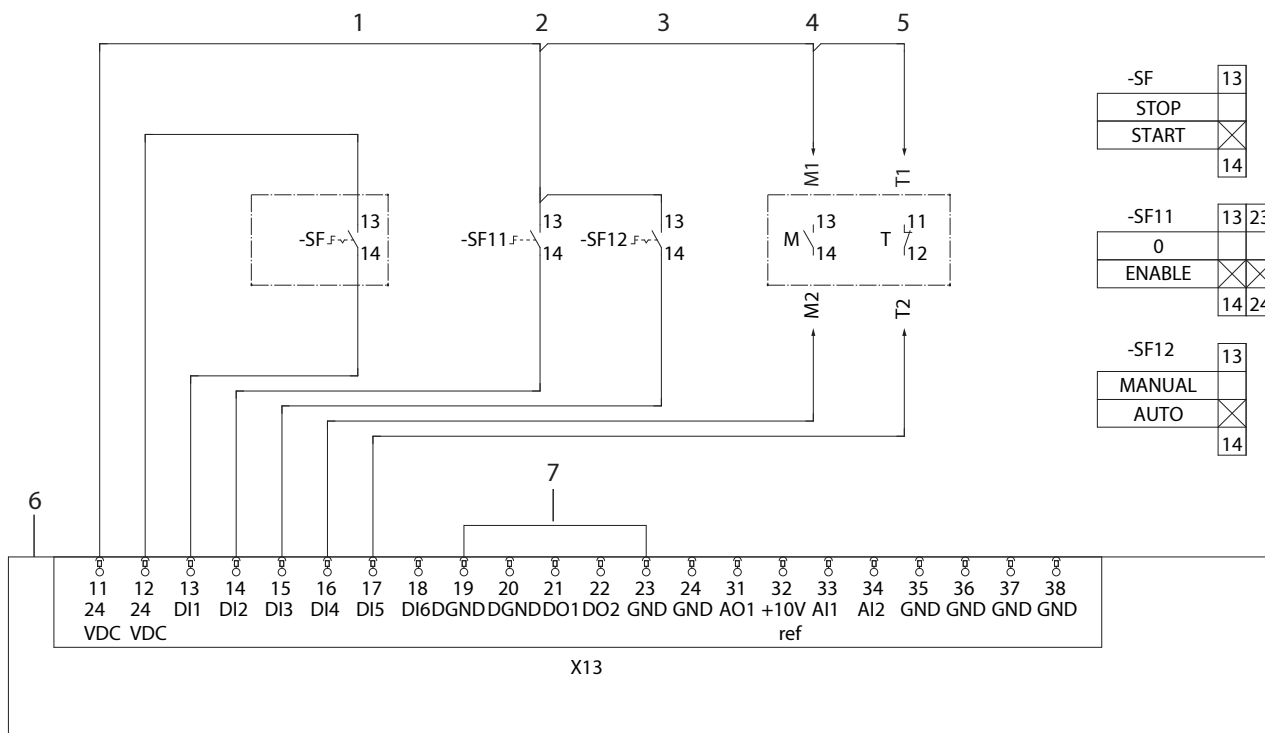

Figure 118: Pre-charging Wiring Diagram, AFE Modules

A	Double-insulated cable	B	Pre-charging circuit
C	Double-insulated cable		

10.3.6 Pre-charging Control Wiring Diagrams



e30bi269.12

Figure 119: Pre-charging Control Wiring Diagram

- | | | | |
|---|---|---|------------------------------------|
| 1 | AFE remote control start/stop | 2 | Mains 0-enable |
| 3 | Pre-charging man-auto | 4 | Main input device status |
| 5 | Main input device tripped (circuit breaker) | 6 | I/O option board of the AFE module |
| 7 | Jump wire (when using internal 24 V supply) | | |

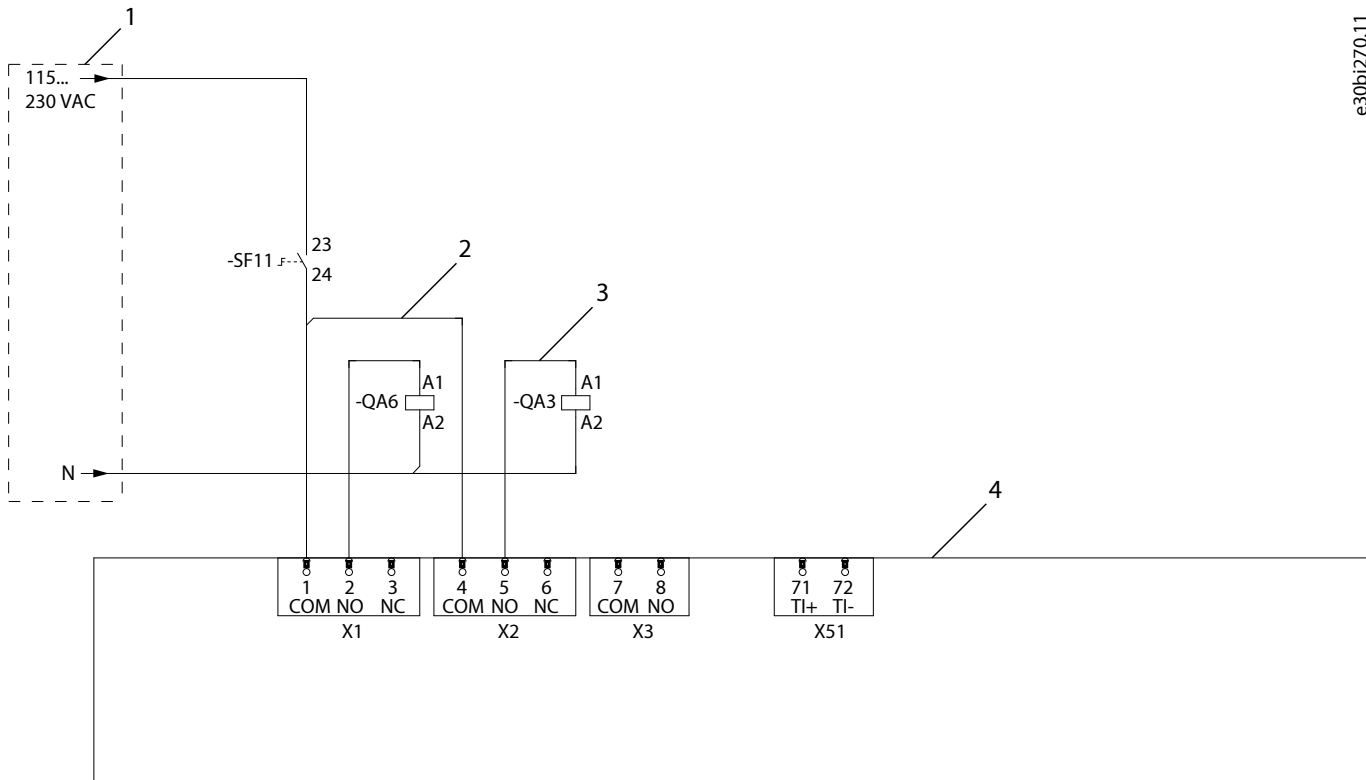

Figure 120: Pre-charging Control Wiring Diagram

1	Short-circuit protected	2	Pre-charging contactor control
3	Main input device control	4	Basic I/O of the control unit of the AFE module

10.3.7 The Pre-charging Function

To avoid high inrush current to drive capacitors, pre-charge the drive before switching on main power.

The pre-charging function uses AFE or GC control unit I/Os and relays. The pre-charging function requires auxiliary voltage for the control unit and the pre-charging circuit. Pre-charging can be operated either locally (manually or automatically) or remotely (manually). Pre-charging is enabled by activating Digital Input 2. Select the MANUAL or AUTO mode by activating/deactivating Digital Input 3 (activated = AUTO). Select remote operation by activating Digital Input 1. Connect the input device, the contactor, or the circuit breaker, the auxiliary contacts to the control unit as described in [10.3.6 Pre-charging Control Wiring Diagrams](#). Connect also the cooling supervision signal from the cooling module if possible. The charging circuit is protected by fuses installed in the fuse-switch disconnector. Turn the switch ON.

Manual operation

Enable pre-charging and switch it to MANUAL mode. Pre-charging starts by pressing the Run button on the control panel of the AFE or grid converter module. The pre-charging contactor closes. When charging is done, the main input device closes and the pre-charging contactor opens. Charging must be performed again after a power outage.

Auto operation

Enable pre-charging and switch it to AUTO mode. Pre-charging starts immediately. The pre-charging contactor closes. When charging is done, the main input device closes and the pre-charging contactor opens. Charging is performed automatically after a power outage.

Remote operation

Enable pre-charging and set it to MANUAL mode. Pre-charging starts by activating Digital Input 1. The AFE or grid converter module starts and the pre-charging contactor closes. When charging is done, the main input device closes and the pre-charging contactor opens. Charging must be performed again after a power outage.

10.3.8 Wiring Diagrams of the +24 V Supply for the Control Unit

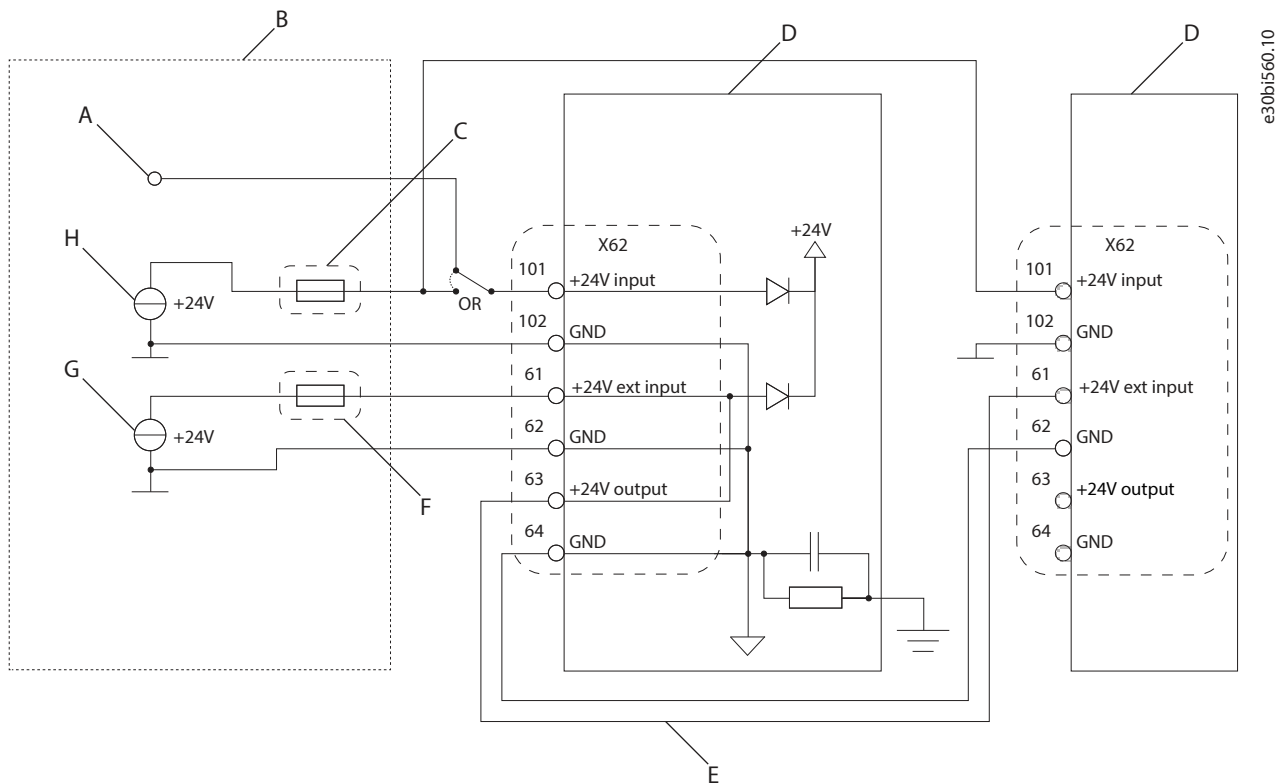
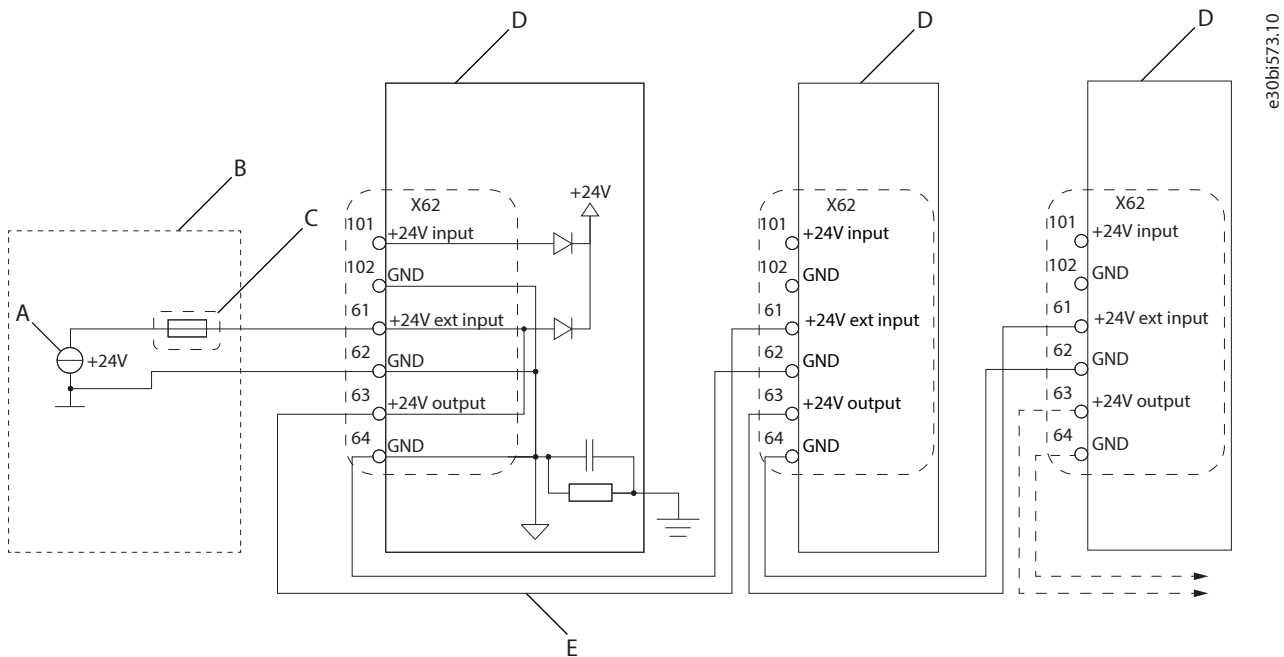

Figure 121: Wiring Diagram of Redundant Supplies

A	Internal +24 V supply (if provided)	B	Reference design, redundant +24 V power
C	3 A fuse	D	Control board
E	Power daisy-chaining	F	Fuse (Fuse rating depends on the complete daisy-chained system configuration. Maximum 10 A.)
G	Primary external supply	H	External redundant supply



e30bi573.10

Figure 122: Wiring Diagram of a Daisy-chained +24 V Supply for the Control Units

A	Normal external supply	B	Reference design, daisy-chained +24 V power
C	Fuse (Fuse rating depends on the complete daisy-chained system configuration. Maximum 10 A.)	D	Control board
E	Power daisy-chaining		

10.4 Cable Sizes

10.4.1 General Cable Size Information

The IEC cable sizing is based on these conditions:

- Ambient temperature of 40 °C (104 °F).
- Cables laid side by side on cable ladders.
- Maximum 9 cables per ladder.
- 3 ladders on top of each other.
- XLPE insulated cables with a maximum conductor temperature of 90 °C (194 °F).

In other conditions, refer to the local safety regulations, the input voltage, and the load current of the drive.

The UL cable sizing is based on these conditions:

- Ambient temperature of 40 °C (104 °F). Conductor sizing is based on NEC table 310.15(B)(16).
- 75 °C (167 °F) rated copper cables.
- Multicore cables installed in cable ducts.
 - If cable ducts are not used, keep sufficient spacing between the cables.
 - Do not stack or bundle the cables without proper spacing for longer than 600 mm (24 in).

In other conditions, refer to the local safety regulations, the input voltage, and the load current of the drive.

NOTICE

Use symmetrical cabling with system modules connected in parallel. Each module must have the same number of cables with an equal cross-section.

The cable size tables for the air-cooled system modules can be found with these links.

- [10.4.2 Mains Cable Size Recommendations for AFE Modules, 380–500 V](#)
- [10.4.3 Motor Cable Sizes Recommendation for Inverter Modules, 380–500 V](#)
- [10.4.4 Motor Cable Size Recommendations for Inverter Modules with Integration Units, 380–500 V](#)
- [10.4.5 Mains Cable Size Recommendations for AFE Modules, UL 480 V](#)
- [10.4.6 Motor Cable Sizes Recommendation for Inverter Modules, UL 480 V](#)
- [10.4.7 Motor Cable Size Recommendations for Inverter Modules with Integration Units, UL 480 V](#)

10.4.2 Mains Cable Size Recommendations for AFE Modules, 380–500 V

Table 41: Mains Cable Size Recommendations for AFE Modules, 380–500 V

Model code ⁽¹⁾	Frame	I _N [A]	Mains cable Cu [mm ²]	Mains cable Al [mm ²]
iC7-60SA3A05-317AE00	AM10/AR10	324	1x (3 x 150 + 70)	2x (3 x 95 + 29)
iC7-60SA3A05-400AE00		409	3x (3 x 50 + 25)	3x (3 x 95 + 29)
iC7-60SA3A05-514AE00		525	3x (3 x 70 + 35)	3x (3 x 120 + 41)
iC7-60SA3A05-580AE00	AM11/AR11	593	2x (3 x 150 + 70)	3x (3 x 150 + 41)
iC7-60SA3A05-650AE00		664	4x (3 x 70 + 35)	4x (3 x 120 + 41)
iC7-60SA3A05-730AE00		746	4x (3 x 95 + 50)	4x (3 x 150 + 41)
iC7-60SA3A05-816AE00		833	3x (3 x 150 + 70)	4x (3 x 150 + 41)
iC7-60SA3A05-920AE00	2xAM10/2xAR10	940	6x (3 x 70 + 35)	4x (3 x 185 + 57)
iC7-60SA3A05-1030E00		1052	4x (3 x 150 + 70)	6x (3 x 150 + 41)
iC7-60SA3A05-1210E00	2xAM11/2xAR11	1236	6x (3 x 120 + 70)	6x (3 x 185 + 57)
iC7-60SA3A05-1410E00		1440	6x (3 x 150 + 70)	8x (3 x 150 + 41)
iC7-60SA3A05-1630E00		1664	6x (3 x 185 + 95)	8x (3 x 185 + 57)
iC7-60SA3A05-1860E00	3xAM11/3xAR11	1899	9x (3 x 120 + 70)	9x (3 x 185 + 57)
iC7-60SA3A05-2120E00		2165	9x (3 x 150 + 70)	12x (3 x 150 + 41)
iC7-60SA3A05-2450E00		2501	9x (3 x 185 + 95)	12x (3 x 185 + 57)
iC7-60SA3A05-2800E00	4xAM11/4xAR11	2859	12x (3 x 150 + 70)	16x (3 x 150 + 41)
iC7-60SA3A05-3270E00		3338	12x (3 x 185 + 95)	16x (3 x 185 + 57)
iC7-60SA3A05-3650E00	5xAM11/5xAR11	3726	15x (3 x 150 + 70)	20x (3 x 150 + 41)
iC7-60SA3A05-4080E00		4165	15x (3 x 150 + 70)	20x (3 x 150 + 41)
iC7-60SA3A05-4500E00	6xAM11/6xAR11	4594	18x (3 x 150 + 70)	24x (3 x 150 + 41)
iC7-60SA3A05-4900E00		5002	18x (3 x 185 + 95)	24x (3 x 185 + 57)

1) Model codes starting with iC7-60SA3A05 or iC7-60SA3H05

10.4.3 Motor Cable Sizes Recommendation for Inverter Modules, 380–500 V

Table 42: Motor Cable Size Recommendations for Inverter Modules, 380–500 V

Model code	Frame	I_N [A]	Motor cable Cu [mm ²]	Motor cable Al [mm ²]	Maximum terminal cable size [mm ²] ⁽¹⁾	Number of grounding terminals/ bolt size	Maximum number of cables/ bolt size
iC7-60SAIN05-385A	IM10	394	3x (3 x 50 + 25)	2x (3 x 120 + 41)	240Cu/Al	1/M8	3/M10
iC7-60SAIN05-480A		490	3x (3 x 70 + 35)	3x (3 x 120 + 41)	240Cu/Al	1/M8	3/M10
iC7-60SAIN05-590A		603	3x (3 x 95 + 50)	3x (3 x 150 + 41)	300Cu/Al	1/M8	3/M10
iC7-60SAIN05-658A	IM11	672	4x (3 x 70 + 35)	4x (3 x 120 + 41)	300Cu/Al	1/M8	4/M12
iC7-60SAIN05-730A		746	4x (3 x 95 + 50)	4x (3 x 150 + 41)	300Cu/Al	1/M8	4/M12
iC7-60SAIN05-820A		838	3x (3 x 150 + 70)	4x (3 x 150 + 41)	300Cu/Al	1/M8	4/M12
iC7-60SAIN05-880A		899	4x (3 x 120 + 70)	4x (3 x 185 + 57)	300Cu/Al	1/M8	4/M12
iC7-60SAIN05-1000	2xIM10	1021	6x (3 x 95 + 50)	6x (3 x 120 + 41)	240Cu/Al	2/M8	6/M10
iC7-60SAIN05-1100		1123	6x (3 x 95 + 50)	6x (3 x 150 + 41)	240Cu/Al	2/M8	6/M10
iC7-60SAIN05-1260	2xIM11	1287	6x (3 x 120 + 70)	8x (3 x 120 + 41)	300Cu/Al	2/M8	8/M12
iC7-60SAIN05-1450		1481	8x (3 x 95 + 50)	8x (3 x 150 + 41)	300Cu/Al	2/M8	8/M12
iC7-60SAIN05-1710		1746	8x (3 x 120 + 70)	8x (3 x 185 + 57)	300Cu/Al	2/M8	8/M12
iC7-60SAIN05-1760	3xIM11	1797	9x (3 x 120 + 70)	12x (3 x 120 + 41)	300Cu/Al	3/M8	12/M12
iC7-60SAIN05-1960		2 001	9x (3 x 150 + 70)	12x (3 x 120 + 41)	300Cu/Al	3/M8	12/M12
iC7-60SAIN05-2150		2 195	9x (3 x 150 + 70)	12x (3 x 150 + 41)	300Cu/Al	3/M8	12/M12
iC7-60SAIN05-2510		2 563	12x (3 x 120 + 70)	12x (3 x 185 + 57)	300Cu/Al	3/M8	12/M12
iC7-60SAIN05-2640	4xIM11	2 695	12x (3 x 120 + 70)	16x (3 x 120 + 41)	300Cu/Al	4/M8	16/M12
iC7-60SAIN05-2880		2 940	12x (3 x 150 + 70)	16x (3 x 150 + 41)	300Cu/Al	4/M8	16/M12
iC7-60SAIN05-3280		3 349	16x (3 x 120 + 70)	16x (3 x 150 + 41)	300Cu/Al	4/M8	16/M12
iC7-60SAIN05-3600	5xIM11	3 675	15x (3 x 150 + 70)	15x (3 x 185 + 57)	300Cu/Al	5/M8	20/M12
iC7-60SAIN05-4060		4 145	20x (3 x 120 + 70)	20x (3 x 150 + 41)	300Cu/Al	5/M8	20/M12
iC7-60SAIN05-4320	6xIM11	4 410	18x (3 x 150 + 70)	18x (3 x 185 + 57)	300Cu/Al	6/M8	24/M12
iC7-60SAIN05-4870		4 972	24x (3 x 120 + 70)	24x (3 x 150 + 41)	300Cu/Al	6/M8	24/M12

1) The bolt hole spacing is 35 mm. Check the width of the cable lug.

10.4.4 Motor Cable Size Recommendations for Inverter Modules with Integration Units, 380–500 V

Table 43: Motor Cable Size Recommendations for Inverter Modules with Integration Units, 380–500 V

Model code	Frame	I_N [A]	Motor cable Cu [mm ²]	Motor cable Al [mm ²]	Maximum terminal cable size [mm ²]	Number of grounding terminals/ bolt size	Maximum number of cables/ bolt size
iC7-60SAIN05-385A	IR10	394	3x (3 x 50 + 25)	2x (3 x 120 + 41)	240Cu/Al	1/M8	4/M10
iC7-60SAIN05-480A		490	3x (3 x 70 + 35)	3x (3 x 120 + 41)	240Cu/Al	1/M8	4/M10
iC7-60SAIN05-590A		603	3x (3 x 95 + 50)	3x (3 x 150 + 41)	300Cu/Al	1/M8	4/M10
iC7-60SAIN05-658A	IR11	672	4x (3 x 70 + 35)	4x (3 x 120 + 41)	300Cu/Al	1/M8	4/M10
iC7-60SAIN05-730A		746	4x (3 x 95 + 50)	4x (3 x 150 + 41)	300Cu/Al	1/M8	4/M10
iC7-60SAIN05-820A		838	3x (3 x 150 + 70)	4x (3 x 150 + 41)	300Cu/Al	1/M8	4/M10
iC7-60SAIN05-880A		899	4x (3 x 120 + 70)	4x (3 x 185 + 57)	300Cu/Al	1/M8	4/M10
iC7-60SAIN05-1000	2xIR10	1021	6x (3 x 95 + 50)	6x (3 x 120 + 41)	240Cu/Al	2/M8	8/M10
iC7-60SAIN05-1100		1123	6x (3 x 95 + 50)	6x (3 x 150 + 41)	240Cu/Al	2/M8	8/M10
iC7-60SAIN05-1260	2xIR11	1287	6x (3 x 120 + 70)	8x (3 x 120 + 41)	300Cu/Al	2/M8	8/M10
iC7-60SAIN05-1450		1481	8x (3 x 95 + 50)	8x (3 x 150 + 41)	300Cu/Al	2/M8	8/M10
iC7-60SAIN05-1710		1746	8x (3 x 120 + 70)	8x (3 x 185 + 57)	300Cu/Al	2/M8	8/M10
iC7-60SAIN05-1760	3xIR11	1797	9x (3 x 120 + 70)	12x (3 x 120 + 41)	300Cu/Al	3/M8	12/M10
iC7-60SAIN05-1960		2 001	9x (3 x 150 + 70)	12x (3 x 120 + 41)	300Cu/Al	3/M8	12/M10
iC7-60SAIN05-2150		2 195	9x (3 x 150 + 70)	12x (3 x 150 + 41)	300Cu/Al	3/M8	12/M10
iC7-60SAIN05-2510		2 563	12x (3 x 120 + 70)	12x (3 x 185 + 57)	300Cu/Al	3/M8	12/M10
iC7-60SAIN05-2640	4xIR11	2 695	12x (3 x 120 + 70)	16x (3 x 120 + 41)	300Cu/Al	4/M8	16/M10
iC7-60SAIN05-2880		2 940	12x (3 x 150 + 70)	16x (3 x 150 + 41)	300Cu/Al	4/M8	16/M10
iC7-60SAIN05-3280		3 349	16x (3 x 120 + 70)	16x (3 x 150 + 41)	300Cu/Al	4/M8	16/M10
iC7-60SAIN05-3600	5xIR11	3 675	15x (3 x 150 + 70)	15x (3 x 185 + 57)	300Cu/Al	5/M8	20/M10
iC7-60SAIN05-4060		4 145	20x (3 x 120 + 70)	20x (3 x 150 + 41)	300Cu/Al	5/M8	20/M10
iC7-60SAIN05-4320	6xIR11	4 410	18x (3 x 150 + 70)	18x (3 x 185 + 57)	300Cu/Al	6/M8	24/M10
iC7-60SAIN05-4870		4 972	24x (3 x 120 + 70)	24x (3 x 150 + 41)	300Cu/Al	6/M8	24/M10

10.4.5 Mains Cable Size Recommendations for AFE Modules, UL 480 V

Table 44: Mains Cable Size Recommendations for AFE Modules, UL 480 V

Model code ⁽¹⁾	Frame	I_N [A]	Mains cable Cu [mm ²]	Mains cable termination, Panduit terminal part number
iC7-60SA3A05-317AE00	AM10/AR10	316	2 x 4/0	LCAX4/0-12-X
iC7-60SA3A05-400AE00		388	2 x 300MCM	LCAX300-12-X
iC7-60SA3A05-514AE00		473	3 x 4/0	LCAX4/0-12-X

Table 44: Mains Cable Size Recommendations for AFE Modules, UL 480 V (continued)

Model code ⁽¹⁾	Frame	I _N [A]	Mains cable Cu [mm ²]	Mains cable termination, Panduit terminal part number
iC7-60SA3A05-580AE00	AM11/AR11	531	3 x 250MCM	LCAX250-12-X
iC7-60SA3A05-650AE00		598	3 x 300MCM	LCAX300-12-X
iC7-60SA3A05-730AE00		664	4 x 250MCM	LCAX250-12-X
iC7-60SA3A05-816AE00		747	4 x 300MCM	LCAX300-12-X
iC7-60SA3A05-920AE00	2 x AM10/2 x AR10	843	4 x 350MCM	LCAX350-12-X
iC7-60SA3A05-1030E00		950	6 x 4/0	LCAX4/0-12-X
iC7-60SA3A05-1210E00	2 x AM11/2 x AR11	1103	6 x 300MCM	LCAX300-12-X
iC7-60SA3A05-1410E00		1276	6 x 350MCM	LCAX350-12-X
iC7-60SA3A05-1630E00		1491	8 x 300MCM	LCAX300-12-X
iC7-60SA3A05-1860E00	3 x AM11/3 x AR11	1705	9 x 300MCM	LCAX300-12-X
iC7-60SA3A05-2120E00		1950	9 x 350MCM	LCAX350-12-X
iC7-60SA3A05-2450E00		2236	12 x 300MCM	LCAX300-12-X
iC7-60SA3A05-2800E00	4 x AM11/4 x AR11	2563	12 x 350MCM	LCAX350-12-X
iC7-60SA3A05-3270E00		2981	16 x 300MCM	LCAX300-12-X
iC7-60SA3A05-3650E00	5 x AM11/5 x AR11	3359	20 x 250MCM	LCAX250-12-X
iC7-60SA3A05-4080E00		3726	20 x 300MCM	LCAX300-12-X
iC7-60SA3A05-4500E00	6 x AM11/6 x AR11	4094	24 x 250MCM	LCAX250-12-X
iC7-60SA3A05-4900E00		4482	24 x 300MCM	LCAX300-12-X

1) Model codes starting with iC7-60SA3A05 or iC7-60SA3H05

10.4.6 Motor Cable Sizes Recommendation for Inverter Modules, UL 480 V

Table 45: Motor Cable Sizes Recommendation for Inverter Modules, UL 480 V

Model code	Frame	I _N [A]	Motor cable Cu [mm ²]	Motor cable termination, Panduit terminal part number	Maximum terminal cable size [mm ²]	Number of grounding terminals/ bolt size	Maximum number of cables/ bolt size
iC7-60SAIN05-385A	IM10	394	2x300MCM	LCAX300-12-X	350MCM	1/M6	3/M10
iC7-60SAIN05-480A		490	3x250MCM	LCAX250-12-X	350MCM	1/M6	3/M10
iC7-60SAIN05-590A		543	3x300MCM	LCAX300-12-X	350MCM	1/M6	3/M10
iC7-60SAIN05-658A	IM11	603	3x350MCM	LCAN350-12-X	350MCM	1/M6	4/M12
iC7-60SAIN05-730A		672	4x250MCM	LCAX250-12-X	350MCM	1/M6	4/M12
iC7-60SAIN05-820A		746	4x300MCM	LCAX300-12-X	350MCM	1/M6	4/M12
iC7-60SAIN05-880A		838	4x350MCM	LCAN350-12-X	350MCM	1/M6	4/M12
iC7-60SAIN05-1000	2xIM10	940	6x4/0	LCAX4/0-12-X	350MCM	2/M6	6/M10
iC7-60SAIN05-1100		1052	6x250MCM	LCAX250-12-X	350MCM	2/M6	6/M10

Table 45: Motor Cable Sizes Recommendation for Inverter Modules, UL 480 V (continued)

Model code	Frame	I_N [A]	Motor cable Cu [mm ²]	Motor cable termination, Panduit terminal part number	Maximum terminal cable size [mm ²]	Number of grounding terminals/ bolt size	Maximum number of cables/ bolt size
iC7-60SAIN05-1260	2xIM11	1174	6x300MCM	LCAX300-12-X	350MCM	2/M6	8/M12
iC7-60SAIN05-1450		1328	8x250MCM	LCAX250-12-X	350MCM	2/M6	8/M12
iC7-60SAIN05-1710		1603	8x350MCM	LCAN350-12-X	350MCM	2/M6	8/M12
iC7-60SAIN05-1760	3xIM11	1807	9x350MCM	LCAN350-12-X	350MCM	3/M6	12/M12
iC7-60SAIN05-1960		1 940	9x350MCM	LCAN350-12-X	350MCM	3/M6	12/M12
iC7-60SAIN05-2150		2 083	12x250MCM	LCAX250-12-X	350MCM	3/M6	12/M12
iC7-60SAIN05-2510		2 389	12x300MCM	LCAX300-12-X	350MCM	3/M6	12/M12
iC7-60SAIN05-2640	4xIM11	2 532	12x350MCM	LCAN350-12-X	350MCM	4/M8	16/M12
iC7-60SAIN05-2880		2 685	16x250MCM	LCAX250-12-X	350MCM	4/M8	16/M12
iC7-60SAIN05-3280		3 114	16x300MCM	LCAX300-12-X	350MCM	4/M8	16/M12
iC7-60SAIN05-3600	5xIM11	3 573	20x250MCM	LCAX250-12-X	350MCM	5/M8	20/M12
iC7-60SAIN05-4060		3 859	20x300MCM	LCAX300-12-X	350MCM	5/M8	20/M12
iC7-60SAIN05-4320	6xIM11	4 176	24x250MCM	LCAX250-12-X	350MCM	6/M8	24/M12
iC7-60SAIN05-4870		4 625	24x300MCM	LCAX300-12-X	350MCM	6/M8	24/M12

10.4.7 Motor Cable Size Recommendations for Inverter Modules with Integration Units, UL 480 V

Table 46: Motor Cable Size Recommendations for Inverter Modules with Integration Units, UL 480 V

Model code	Frame	I_N [A]	Motor cable Cu [mm ²]	Motor cable termination, Panduit terminal part number	Maximum terminal cable size [mm ²]	Number of grounding terminals/ bolt size	Maximum number of cables/ bolt size
iC7-60SAIN05-385A	IR10	394	2x300MCM	LCAX300-12-X	500MCM	1/M8	4/M10
iC7-60SAIN05-480A		490	3x250MCM	LCAX250-12-X	500MCM	1/M8	4/M10
iC7-60SAIN05-590A		543	3x300MCM	LCAX300-12-X	500MCM	1/M8	4/M10
iC7-60SAIN05-658A	IR11	603	3x350MCM	LCAX350-12-X	500MCM	1/M8	4/M10
iC7-60SAIN05-730A		672	4x250MCM	LCAX250-12-X	500MCM	1/M8	4/M10
iC7-60SAIN05-820A		746	4x300MCM	LCAX300-12-X	500MCM	1/M8	4/M10
iC7-60SAIN05-880A		838	4x350MCM	LCAX350-12-X	500MCM	1/M8	4/M10
iC7-60SAIN05-1000	2xIR10	940	6x4/0	LCAX4/0-12-X	500MCM	2/M8	8/M10
iC7-60SAIN05-1100		1052	6x250MCM	LCAX250-12-X	500MCM	2/M8	8/M10
iC7-60SAIN05-1260	2xIR11	1174	6x300MCM	LCAX300-12-X	500MCM	2/M8	8/M10
iC7-60SAIN05-1450		1328	8x250MCM	LCAX250-12-X	500MCM	2/M8	8/M10
iC7-60SAIN05-1710		1603	8x350MCM	LCAX350-12-X	500MCM	2/M8	8/M10

Table 46: Motor Cable Size Recommendations for Inverter Modules with Integration Units, UL 480 V (continued)

Model code	Frame	I_N [A]	Motor cable Cu [mm ²]	Motor cable termination, Panduit terminal part number	Maximum terminal cable size [mm ²]	Number of grounding terminals/ bolt size	Maximum number of cables/ bolt size
iC7-60SAIN05-1760	3xIR11	1807	9x350MCM	LCAX350-12-X	500MCM	3/M8	12/M10
iC7-60SAIN05-1960		1 940	9x350MCM	LCAX350-12-X	500MCM	3/M8	12/M10
iC7-60SAIN05-2150		2 083	12x250MCM	LCAX250-12-X	500MCM	3/M8	12/M10
iC7-60SAIN05-2510		2 389	12x300MCM	LCAX300-12-X	500MCM	3/M8	12/M10
iC7-60SAIN05-2640	4xIR11	2 532	12x350MCM	LCAX350-12-X	500MCM	4/M8	16/M12
iC7-60SAIN05-2880		2 685	16x250MCM	LCAX250-12-X	500MCM	4/M8	16/M12
iC7-60SAIN05-3280		3 114	16x300MCM	LCAX300-12-X	500MCM	4/M8	16/M12
iC7-60SAIN05-3600	5xIR11	3 573	20x250MCM	LCAX250-12-X	500MCM	5/M8	20/M12
iC7-60SAIN05-4060		3 859	20x300MCM	LCAX300-12-X	500MCM	5/M8	20/M12
iC7-60SAIN05-4320	6xIR11	4 176	24x250MCM	LCAX250-12-X	500MCM	6/M8	24/M12
iC7-60SAIN05-4870		4 625	24x300MCM	LCAX300-12-X	500MCM	6/M8	24/M12

10.5 Fuses

10.5.1 List of Fuse Size Information

The fuse size tables for the air-cooled system modules can be found with these links.

- [10.5.2 AC Fuses for AFE, 380–500 V AC](#)
- [10.5.3 DC Fuses for AFE, 465–740 V DC](#)
- [10.5.4 DC Fuses for Inverter Modules, 465–740 V DC](#)

10.5.2 AC Fuses for AFE, 380–500 V AC

Table 47: AC Fuses for AFE, 380–500 V AC

Model code ⁽¹⁾	Frame	Rated current I_L [A]	Number of fuses	Fuse size	Mersen part number ⁽²⁾	Fuse U_n [V]	Fuse I_n [A]	Minimum $I_{cp,mr}$ [A]
iC7-60SA3x05-317AE00	AM10/ AR10	317	3	33	PC33UD69V550TF	690	550	3300
iC7-60SA3x05-400AE00		400			PC33UD69V550TF	690	550	3300
iC7-60SA3x05-514AE00		514			PC33UD69V700TF	690	700	4800
iC7-60SA3x05-580AE00	AM11/ AR11	580	6	33	PC33UD69V550TF	690	550	6600
iC7-60SA3x05-650AE00		650			PC33UD69V550TF	690	550	6600
iC7-60SA3x05-730AE00		730			PC33UD69V550TF	690	550	6600
iC7-60SA3x05-816AE00		816			PC33UD69V550TF	690	550	6600
iC7-60SA3x05-920E00	2 x	920	6	33	PC33UD69V700TF	690	700	–
iC7-60SA3x05-1030E00	AM10/ 2 x AR10	1030			PC33UD69V700TF	690	700	–

Table 47: AC Fuses for AFE, 380–500 V AC (continued)

Model code ⁽¹⁾	Frame	Rated current I_L [A]	Number of fuses	Fuse size	Mersen part number ⁽²⁾	Fuse U_n [V]	Fuse I_n [A]	Minimum $I_{cp,mr}$ [A]
iC7-60SA3x05-1210E00	2 x AM11/2 x AR11	1210	12	33	PC33UD69V550TF	690	550	–
iC7-60SA3x05-1410E00		1410			PC33UD69V550TF	690	550	–
iC7-60SA3x05-1630E00		1630			PC33UD69V550TF	690	550	–
iC7-60SA3x05-1860E00	3 x AM11/3 x AR11	1860	18	33	PC33UD69V550TF	690	550	–
iC7-60SA3x05-2120E00		2120			PC33UD69V550TF	690	550	–
iC7-60SA3x05-2450E00		2450			PC33UD69V550TF	690	550	–
iC7-60SA3x05-2800E00	4 x AM11/4 x AR11	2800	24	33	PC33UD69V550TF	690	550	–
iC7-60SA3x05-3270E00		3270			PC33UD69V550TF	690	550	–
iC7-60SA3x05-3650E00	5 x AM11/5 x AR11	3650	30	33	PC33UD69V550TF	690	550	–
iC7-60SA3x05-4080E00		4080			PC33UD69V550TF	690	550	–
iC7-60SA3x05-4500E00	6 x AM11/6 x AR11	4500	36	33	PC33UD69V550TF	690	550	–
iC7-60SA3x05-4900E00		4900			PC33UD69V550TF	690	550	–

1) Model codes starting with iC7-60SA3A05 or iC7-60SA3H05

2) Available as option +AJFX

10.5.3 DC Fuses for AFE, 465–740 V DC

Table 48: DC Fuses for AFE, 465–740 V DC

Model code ⁽¹⁾	Frame	Rated current I_L [A]	Number of fuses	Fuse size	Mersen part number	Fuse U_n [V]	Fuse I_n [A]
iC7-60SA3x05-317AE00	AM10/AR10	317	2	73	PC73UD13C630TF	1250	630
iC7-60SA3x05-400AE00		400			PC73UD13C800TF	1250	800
iC7-60SA3x05-514AE00		514			PC73UD10C1000TF	1000	1000
iC7-60SA3x05-580AE00	AM11/AR11	580	2	73	PC73UD90V13CTF	900	1250
iC7-60SA3x05-650AE00		650			PC73UD90V13CTF	900	1250
iC7-60SA3x05-730AE00		730			PC73UD85V14CTF	850	1400
iC7-60SA3x05-816AE00		816			PC73UD85V14CTF	850	1400
iC7-60SA3x05-920E00	2 x AM10/ 2 x AR10	920	4	73	PC73UD13C800TF	1250	800
iC7-60SA3x05-1030E00		1030			PC73UD10C1000TF	1000	1000
iC7-60SA3x05-1210E00	2 x AM11/ 2 x AR11	1210	4	73	PC73UD90V13CTF	900	1250
iC7-60SA3x05-1410E00		1410			PC73UD85V14CTF	850	1400
iC7-60SA3x05-1630E00		1630			PC73UD85V14CTF	850	1400

Table 48: DC Fuses for AFE, 465–740 V DC (continued)

Model code ⁽¹⁾	Frame	Rated current I_L [A]	Number of fuses	Fuse size	Mersen part number	Fuse U_n [V]	Fuse I_n [A]
iC7-60SA3x05-1860E00	3 x AM11/ 3 x AR11	1860	6	73	PC73UD90V13CTF	900	1250
iC7-60SA3x05-2120E00		2120			PC73UD90V13CTF	900	1250
iC7-60SA3x05-2450E00		2450			PC73UD85V14CTF	850	1400
iC7-60SA3x05-2800E00	4 x AM11/ 4 x AR11	2800	8	73	PC73UD90V13CTF	900	1250
iC7-60SA3x05-3270E00		3270			PC73UD85V14CTF	850	1400
iC7-60SA3x05-3650E00	5 x AM11/ 5 x AR11	3650	10	73	PC73UD85V14CTF	850	1400
iC7-60SA3x05-4080E00		4080			PC73UD85V14CTF	850	1400
iC7-60SA3x05-4500E00	6 x AM11/ 6 x AR11	4500	12	73	PC73UD85V14CTF	850	1400
iC7-60SA3x05-4900E00		4900			PC73UD85V14CTF	850	1400

1) Model codes starting with iC7-60SA3A05 or iC7-60SA3H05

10.5.4 DC Fuses for Inverter Modules, 465–740 V DC

Table 49: DC Fuses for Inverter Modules, 465–740 V DC

Model code	Frame	Rated current I_L [A]	Number of fuses	Fuse size	Mersen part number	Fuse U_n [V]	Fuse I_n [A]
iC7-60SAIN05-385AE00	IM10/IR10	385	2	73	PC73UD13C630TF	1250	630
iC7-60SAIN05-480AE00		480			PC73UD13C800TF	1250	800
iC7-60SAIN05-590AE00		590			PC73UD10C1000TF	1000	1000
iC7-60SAIN05-658AE00	IM11/IR11	658	2	73	PC73UD90V13CTF	900	1250
iC7-60SAIN05-730AE00		730			PC73UD90V13CTF	900	1250
iC7-60SAIN05-820AE00		820			PC73UD85V14CTF	850	1400
iC7-60SAIN05-880AE00		880			PC73UD85V14CTF	850	1400
iC7-60SAIN05-1000E00	2 x IM10/2 x IR10	1000	4	73	PC73UD13C800TF	1250	800
iC7-60SAIN05-1100E00		1100			PC73UD10C1000TF	1000	1000
iC7-60SAIN05-1260E00	2 x IM11/2 x IR11	1260	4	73	PC73UD90V13CTF	900	1250
iC7-60SAIN05-1450E00		1450			PC73UD90V13CTF	900	1250
iC7-60SAIN05-1710E00		1710			PC73UD85V14CTF	850	1400
iC7-60SAIN05-1760E00	3 x IM11/3 x IR11	1760	6	73	PC73UD90V13CTF	900	1250
iC7-60SAIN05-1960E00		1960			PC73UD90V13CTF	900	1250
iC7-60SAIN05-2150E00		2150			PC73UD90V13CTF	900	1250
iC7-60SAIN05-2510E00		2510			PC73UD85V14CTF	850	1400
iC7-60SAIN05-2640E00	4 x IM11/4 x IR11	2640	8	73	PC73UD90V13CTF	900	1250
iC7-60SAIN05-2880E00		2880			PC73UD90V13CTF	900	1250
iC7-60SAIN05-3280E00		3280			PC73UD85V14CTF	850	1400

Table 49: DC Fuses for Inverter Modules, 465–740 V DC (continued)

Model code	Frame	Rated current I_L [A]	Number of fuses	Fuse size	Mersen part number	Fuse U_n [V]	Fuse I_n [A]
iC7-60SAIN05-3600E00	5 x IM11/5 x IR11	3600	10	73	PC73UD90V13CTF	900	1250
iC7-60SAIN05-4060E00		4060			PC73UD85V14CTF	850	1400
iC7-60SAIN05-4320E00	6 x IM11/6 x IR11	4320	12	73	PC73UD90V13CTF	900	1250
iC7-60SAIN05-4870E00		4870			PC73UD85V14CTF	850	1400

10.6 Current Ratings

10.6.1 General Current Rating Information

The current rating tables show the ratings of the system modules at relevant voltage ratings. The power rating tables for the different products can be found with these links.

- [10.6.2 Current Ratings for Regenerative AFE Module, 400 V AC \(465–650 V DC\)](#)
- [10.6.3 Current Ratings for Regenerative AFE Module, UL 480 V AC \(650–740 V DC\)](#)
- [10.6.4 Current Ratings for Regenerative AFE Module, 500 V AC \(650–740 V DC\)](#)
- [10.6.5 Current Ratings for Low-harmonic AFE Module, 400 V AC \(465–650 V DC\)](#)
- [10.6.6 Current Ratings for Low-harmonic AFE Module, UL 480 V AC \(650–740 V DC\)](#)
- [10.6.7 Current Ratings for Low-harmonic AFE Module, 500 V AC \(650–740 V DC\)](#)
- [10.6.8 Current Ratings for Inverter Module, 400 V AC \(465–650 V DC\)](#)
- [10.6.9 Current Ratings for Inverter Module, UL 460 V AC \(650–740 V DC\)](#)
- [10.6.10 Current Ratings for Inverter Module, 500 V AC \(650–740 V DC\)](#)
- [10.6.11 Current Ratings for Grid Converter Module, 400 V AC \(465–650 V DC\)](#)
- [10.6.12 Current Ratings for Grid Converter Module, 500 V AC \(650–740 V DC\)](#)

Table 50: Abbreviations Used in the Rating Tables

Abbreviation	Description
I_N	Nominal current. If the process does not require any overloadability or the process does not include any load variation or margin for overloadability, the dimensioning can be done according to this current.
I_L	Nominal current with low overload (110%). Allows a +10% load variation for 1 minute every 5 minutes.
I_H	Nominal current with high overload (150%). Allows a +50% load variation for 1 minute every 5 minutes.
I_{peak}	Start current. Available for 3 s at start, then as long as the system module temperature allows. Relevant for inverter modules.
I_{N-DC}	DC current
S_L	Apparent power at low overload
P_L	Output power at low overload
P_H	Output power at high overload

10.6.2 Current Ratings for Regenerative AFE Module, 400 V AC (465–650 V DC)

Table 51: Current Ratings for Regenerative AFE Module, 400 V AC (465–650 V DC)

Model code	Frame	AC ratings				DC ratings		
		S _L [kVA]	I _N [A]	I _L [A]	I _H [A]	I _{N-DC} [A]	P _L [kW]	P _H [kW]
iC7-60SA3A05-317A	AM10/ AR10	220	324	317	263	371	216	179
iC7-60SA3A05-400A		278	409	400	327	469	272	223
iC7-60SA3A05-514A		357	525	514	426	602	349	290
iC7-60SA3A05-580A	AM11/ AR11	402	593	580	464	677	394	316
iC7-60SA3A05-650A		451	664	650	525	760	442	357
iC7-60SA3A05-730A		506	746	730	591	852	496	402
iC7-60SA3A05-816A		566	833	816	678	953	555	461
iC7-60SA3A05-920A	2 x AM10/ AR10	638	940	920	735	1075	625	500
iC7-60SA3A05-1030		714	1052	1030	850	1203	700	578
iC7-60SA3A05-1210	2 x AM11/ AR11	839	1236	1210	980	1413	822	666
iC7-60SA3A05-1410		977	1440	1410	1140	1647	958	775
iC7-60SA3A05-1630		1130	1664	1630	1360	1903	1107	924
iC7-60SA3A05-1860	3 x AM11/ AR11	1289	1899	1860	1575	2172	1263	1070
iC7-60SA3A05-2120		1469	2165	2120	1838	2475	1440	1248
iC7-60SA3A05-2450		1698	2501	2450	2030	2861	1664	1379
iC7-60SA3A05-2800	4 x AM11/ AR11	1940	2859	2800	2231	3268	1902	1515
iC7-60SA3A05-3270		2266	3338	3270	2710	3817	2221	1840
iC7-60SA3A05-3650	5 x AM11/ AR11	2529	3726	3650	2888	4260	2479	1961
iC7-60SA3A05-4080		2827	4165	4080	3390	4761	2771	2302
iC7-60SA3A05-4500	6 x AM11/ AR11	3118	4594	4500	3544	5251	3056	2407
iC7-60SA3A05-4900		3395	5002	4900	4070	5719	3327	2764

10.6.3 Current Ratings for Regenerative AFE Module, UL 480 V AC (650–740 V DC)

Table 52: Current Ratings for Regenerative AFE Module, UL 480 V AC (650–740 V DC)

Model code	Frame	AC ratings				DC ratings		
		S _L [kVA]	I _N [A]	I _L [A]	I _H [A]	I _{N-DC} [A]	P _L [kW]	P _H [kW]
iC7-60SA3A05-317A	AM10/ AR10	257	316	309	256	361	252	209
iC7-60SA3A05-400A		316	388	380	298	445	310	243
iC7-60SA3A05-514A		385	473	463	385	542	378	314
iC7-60SA3A05-580A	AM11/ AR11	433	531	520	424	608	424	346
iC7-60SA3A05-650A		487	598	585	470	684	477	383
iC7-60SA3A05-730A		541	664	650	511	759	530	417
iC7-60SA3A05-816A		608	747	731	607	853	596	495

Table 52: Current Ratings for Regenerative AFE Module, UL 480 V AC (650–740 V DC) (continued)

Model code	Frame	AC ratings				DC ratings		
		S _L [kVA]	I _N [A]	I _L [A]	I _H [A]	I _{N-DC} [A]	P _L [kW]	P _H [kW]
iC7-60SA3A05-920A	2 x AM10/ AR10	686	843	825	639	964	673	521
iC7-60SA3A05-1030		774	950	930	770	1086	758	628
iC7-60SA3A05-1210	2 x AM11/ AR11	898	1103	1080	880	1262	880	717
iC7-60SA3A05-1410		1040	1276	1250	1030	1460	1019	840
iC7-60SA3A05-1630		1214	1491	1460	1210	1705	1190	986
iC7-60SA3A05-1860	3 x AM11/ AR11	1389	1705	1670	1363	1949	1361	1111
iC7-60SA3A05-2120		1588	1950	1910	1533	2230	1557	1250
iC7-60SA3A05-2450		1821	2236	2190	1820	2557	1785	1483
iC7-60SA3A05-2800	4 x AM11/ AR11	2087	2563	2510	1874	2930	2046	1527
iC7-60SA3A05-3270		2428	2981	2920	2430	3408	2380	1980
iC7-60SA3A05-3650	5 x AM11/ AR11	2736	3359	3290	2726	3840	2681	2222
iC7-60SA3A05-4080		3035	3726	3650	3030	4260	2974	2469
iC7-60SA3A05-4500	6 x AM11/ AR11	3334	4094	4010	3152	4681	3268	2569
iC7-60SA3A05-4900		3650	4482	4390	3640	5124	3577	2966

10.6.4 Current Ratings for Regenerative AFE Module, 500 V AC (650–740 V DC)

Table 53: Current Ratings for Regenerative AFE Module, 500 V AC (650–740 V DC)

Model code	Frame	AC ratings				DC ratings		
		S _L [kVA]	I _N [A]	I _L [A]	I _H [A]	I _{N-DC} [A]	P _L [kW]	P _H [kW]
iC7-60SA3A05-317A	AM10/ AR10	268	316	309	256	361	263	218
iC7-60SA3A05-400A		330	388	380	298	445	323	253
iC7-60SA3A05-514A		401	473	463	385	542	393	327
iC7-60SA3A05-580A	AM11/ AR11	451	531	520	424	608	442	360
iC7-60SA3A05-650A		507	598	585	470	683	497	399
iC7-60SA3A05-730A		563	664	650	511	760	552	434
iC7-60SA3A05-816A		634	747	731	607	854	621	516
iC7-60SA3A05-920A	2 x AM10/ AR10	715	843	825	639	963	701	543
iC7-60SA3A05-1030		806	950	930	770	1086	790	654
iC7-60SA3A05-1210	2 x AM11/ AR11	936	1103	1080	880	1261	917	747
iC7-60SA3A05-1410		1083	1276	1250	1030	1459	1061	875
iC7-60SA3A05-1630		1265	1491	1460	1210	1704	1240	1027
iC7-60SA3A05-1860	3 x AM11/ AR11	1447	1705	1670	1363	1949	1418	1157
iC7-60SA3A05-2120		1655	1950	1910	1533	2229	1622	1302
iC7-60SA3A05-2450		1897	2236	2190	1820	2557	1859	1545

Table 53: Current Ratings for Regenerative AFE Module, 500 V AC (650–740 V DC) (continued)

Model code	Frame	AC ratings				DC ratings		
		S _L [kVA]	I _N [A]	I _L [A]	I _H [A]	I _{N-DC} [A]	P _L [kW]	P _H [kW]
iC7-60SA3A05-2800	4 x AM11/ AR11	2174	2563	2510	1874	2930	2131	1591
iC7-60SA3A05-3270		2529	2981	2920	2430	3408	2479	2063
iC7-60SA3A05-3650	5 x AM11/ AR11	2850	3359	3290	2726	3840	2793	2314
iC7-60SA3A05-4080		3161	3726	3650	3030	4260	3098	2572
iC7-60SA3A05-4500	6 x AM11/ AR11	3473	4094	4010	3152	4681	3404	2676
iC7-60SA3A05-4900		3802	4482	4390	3640	5124	3726	3090

10.6.5 Current Ratings for Low-harmonic AFE Module, 400 V AC (465–650 V DC)

Table 54: Current Ratings for Low-harmonic AFE Module, 400 V AC (465–650 V DC)

Model code	Frame	AC ratings				DC ratings		
		S _L [kVA]	I _N [A]	I _L [A]	I _H [A]	I _{N-DC} [A]	P _L [kW]	P _H [kW]
iC7-60SA3H05-317A	AM10/ AR10	220	324	317	263	371	216	179
iC7-60SA3H05-400A		278	409	400	327	469	272	223
iC7-60SA3H05-514A		357	525	514	426	602	349	290
iC7-60SA3H05-580A	AM11/ AR11	402	593	580	464	677	394	316
iC7-60SA3H05-650A		451	664	650	525	760	442	357
iC7-60SA3H05-730A		506	746	730	591	852	496	402
iC7-60SA3H05-816A		566	833	816	678	953	555	461
iC7-60SA3H05-920A	2 x AM10/ AR10	638	940	920	735	1075	625	500
iC7-60SA3H05-1030		714	1052	1030	850	1203	700	578
iC7-60SA3H05-1210	2 x AM11/ AR11	839	1236	1210	980	1413	822	666
iC7-60SA3H05-1410		977	1440	1410	1140	1647	958	775
iC7-60SA3H05-1630		1130	1664	1630	1360	1903	1107	924
iC7-60SA3H05-1860	3 x AM11/ AR11	1289	1899	1860	1575	2172	1263	1070
iC7-60SA3H05-2120		1469	2165	2120	1838	2475	1440	1248
iC7-60SA3H05-2450		1698	2501	2450	2030	2861	1664	1379
iC7-60SA3H05-2800	4 x AM11/ AR11	1940	2859	2800	2231	3268	1902	1515
iC7-60SA3H05-3270		2266	3338	3270	2710	3817	2221	1840
iC7-60SA3H05-3650	5 x AM11/ AR11	2529	3726	3650	2888	4260	2479	1961
iC7-60SA3H05-4080		2827	4165	4080	3390	4761	2771	2302
iC7-60SA3H05-4500	6 x AM11/ AR11	3118	4594	4500	3544	5251	3056	2407
iC7-60SA3H05-4900		3395	5002	4900	4070	5719	3327	2764

10.6.6 Current Ratings for Low-harmonic AFE Module, UL 480 V AC (650–740 V DC)

Table 55: Current Ratings for Low-harmonic AFE Module, UL 480 V AC (650–740 V DC)

Model code	Frame	AC ratings				DC ratings		
		S _L [kVA]	I _N [A]	I _L [A]	I _H [A]	I _{N-DC} [A]	P _L [kW]	P _H [kW]
iC7-60SA3H05-317A	AM10/AR10	257	316	309	256	361	252	209
iC7-60SA3H05-400A		316	388	380	298	445	310	243
iC7-60SA3H05-514A		385	473	463	385	542	378	314
iC7-60SA3H05-580A	AM11/AR11	433	531	520	424	608	424	346
iC7-60SA3H05-650A		487	598	585	470	684	477	383
iC7-60SA3H05-730A		541	664	650	511	759	530	417
iC7-60SA3H05-816A		608	747	731	607	853	596	495
iC7-60SA3H05-920A	2 x AM10/ AR10	686	843	825	639	964	673	521
iC7-60SA3H05-1030		774	950	930	770	1086	758	628
iC7-60SA3H05-1210	2 x AM11/ AR11	898	1103	1080	880	1262	880	717
iC7-60SA3H05-1410		1040	1276	1250	1030	1460	1019	840
iC7-60SA3H05-1630		1214	1491	1460	1210	1705	1190	986
iC7-60SA3H05-1860	3 x AM11/ AR11	1389	1705	1670	1363	1949	1361	1111
iC7-60SA3H05-2120		1588	1950	1910	1533	2230	1557	1250
iC7-60SA3H05-2450		1821	2236	2190	1820	2557	1785	1483
iC7-60SA3H05-2800	4 x AM11/ AR11	2087	2563	2510	1874	2930	2046	1527
iC7-60SA3H05-3270		2428	2981	2920	2430	3408	2380	1980
iC7-60SA3H05-3650	5 x AM11/ AR11	2736	3359	3290	2726	3840	2681	2222
iC7-60SA3H05-4080		3035	3726	3650	3030	4260	2974	2469
iC7-60SA3H05-4500	6 x AM11/ AR11	3334	4094	4010	3152	4681	3268	2569
iC7-60SA3H05-4900		3650	4482	4390	3640	5124	3577	2966

10.6.7 Current Ratings for Low-harmonic AFE Module, 500 V AC (650–740 V DC)

Table 56: Current Ratings for Low-harmonic AFE Module, 500 V AC (650–740 V DC)

Model code	Frame	AC ratings				DC ratings		
		S _L [kVA]	I _N [A]	I _L [A]	I _H [A]	I _{N-DC} [A]	P _L [kW]	P _H [kW]
iC7-60SA3H05-317A	AM10/ AR10	268	316	309	256	361	263	218
iC7-60SA3H05-400A		330	388	380	298	445	323	253
iC7-60SA3H05-514A		401	473	463	385	542	393	327
iC7-60SA3H05-580A	AM11/ AR11	451	531	520	424	608	442	360
iC7-60SA3H05-650A		507	598	585	470	683	497	399
iC7-60SA3H05-730A		563	664	650	511	760	552	434
iC7-60SA3H05-816A		634	747	731	607	854	621	516

Table 56: Current Ratings for Low-harmonic AFE Module, 500 V AC (650–740 V DC) (continued)

Model code	Frame	AC ratings				DC ratings		
		S_L [kVA]	I_N [A]	I_L [A]	I_H [A]	I_{N-DC} [A]	P_L [kW]	P_H [kW]
iC7-60SA3H05-920A	2 x AM10/ AR10	715	843	825	639	963	701	543
iC7-60SA3H05-1030		806	950	930	770	1086	790	654
iC7-60SA3H05-1210	2 x AM11/ AR11	936	1103	1080	880	1261	917	747
iC7-60SA3H05-1410		1083	1276	1250	1030	1459	1061	875
iC7-60SA3H05-1630		1265	1491	1460	1210	1704	1240	1027
iC7-60SA3H05-1860	3 x AM11/ AR11	1447	1705	1670	1363	1949	1418	1157
iC7-60SA3H05-2120		1655	1950	1910	1533	2229	1622	1302
iC7-60SA3H05-2450		1897	2236	2190	1820	2557	1859	1545
iC7-60SA3H05-2800	4 x AM11/ AR11	2174	2563	2510	1874	2930	2131	1591
iC7-60SA3H05-3270		2529	2981	2920	2430	3408	2479	2063
iC7-60SA3H05-3650	5 x AM11/ AR11	2850	3359	3290	2726	3840	2793	2314
iC7-60SA3H05-4080		3161	3726	3650	3030	4260	3098	2572
iC7-60SA3H05-4500	6 x AM11/ AR11	3473	4094	4010	3152	4681	3404	2676
iC7-60SA3H05-4900		3802	4482	4390	3640	5124	3726	3090

10.6.8 Current Ratings for Inverter Module, 400 V AC (465–650 V DC)

Table 57: Current Ratings for Inverter Module, 400 V AC (465–650 V DC)

Model code	Frame	AC current				Typical motor power, 400 V AC		DC current
		I_N [A]	I_L [A]	I_H [A]	I_{peak} [A]	P_L [kW]	P_H [kW]	I_{N-DC} [A]
iC7-60SAIN05-385A	IM10/IR10	394	385	320	544	200	160	410
iC7-60SAIN05-480A		490	480	399	679	250	200	510
iC7-60SAIN05-590A		603	590	490	833	315	250	641
iC7-60SAIN05-658A	IM11/IR11	672	658	547	930	355	250	721
iC7-60SAIN05-730A		746	730	606	1031	400	315	813
iC7-60SAIN05-820A		838	820	681	1158	450	355	913
iC7-60SAIN05-880A ⁽¹⁾		899	880	731	1243	500	400	1015
iC7-60SAIN05-1000	2 x IM10/ IR10	1021	1000	830	1411	560	450	1138
iC7-60SAIN05-1100		1123	1100	913	1553	630	500	1280
iC7-60SAIN05-1260	2 x IM11/ IR11	1287	1260	1050	1785	710	560	1441
iC7-60SAIN05-1450		1481	1450	1210	2057	800	630	1625
iC7-60SAIN05-1710 ⁽¹⁾		1746	1710	1420	2414	900	710	1826

Table 57: Current Ratings for Inverter Module, 400 V AC (465–650 V DC) (continued)

Model code	Frame	AC current				Typical motor power, 400 V AC		DC current
		I _N [A]	I _L [A]	I _H [A]	I _{peak} [A]	P _L [kW]	P _H [kW]	I _{N-DC} [A]
iC7-60SAIN05-1760	3 x IM11/ IR11	1797	1760	1470	2499	1000	800	2030
iC7-60SAIN05-1960		2001	1960	1630	2771	1100	900	2234
iC7-60SAIN05-2150		2195	2150	1790	3043	1200	1000	2436
iC7-60SAIN05-2510 ⁽¹⁾		2563	2510	2090	3553	1400	1100	2841
iC7-60SAIN05-2640	4 x IM11/ IR11	2695	2640	2200	3740	1500	1200	3045
iC7-60SAIN05-2880		2940	2880	2400	4080	1600	1300	3247
iC7-60SAIN05-3280 ⁽¹⁾		3349	3280	2730	4641	1800	1500	3652
iC7-60SAIN05-3600	5 x IM11/ IR11	3675	3600	2990	5083	2000	1600	4058
iC7-60SAIN05-4060		4145	4060	3370	5729	2200	1800	4465
iC7-60SAIN05-4320	6 x IM11/ IR11	4410	4320	3590	6103	2400	1900	4871
iC7-60SAIN05-4870		4972	4870	4050	6885	2700	2200	5478

¹⁾ For high overload ratings, derating starts from 35 °C (95 °F) in combinations with +AEU1, +AEU2.

10.6.9 Current Ratings for Inverter Module, UL 460 V AC (650–740 V DC)

Table 58: Current Ratings for Inverter Module, UL 460 V AC (650–740 V DC)

Model code	Frame	AC current				Typical motor power, 460 V AC		DC current
		I _N [A]	I _L [A]	I _H [A]	I _{peak} [A]	P _L [Hp]	P _H [Hp]	I _{N-DC} [A]
iC7-60SAIN05-385A	IM10/IR10	394	385	320	544	300	250	380
iC7-60SAIN05-480A		490	480	399	679	350	300	443
iC7-60SAIN05-590A		543	531	441	750	450	350	570
iC7-60SAIN05-658A	IM11/IR11	603	590	490	833	500	350	632
iC7-60SAIN05-730A		672	658	547	930	550	450	695
iC7-60SAIN05-820A		746	730	606	1031	600	500	758
iC7-60SAIN05-880A		838	820	681	1158	700	550	883
iC7-60SAIN05-1000	2 x IM10/ IR10	940	920	764	1299	750	550	948
iC7-60SAIN05-1100		1052	1030	855	1454	850	650	1073
iC7-60SAIN05-1260	2 x IM11/ IR11	1174	1150	960	1632	950	750	1200
iC7-60SAIN05-1450		1328	1300	1080	1836	1100	850	1389
iC7-60SAIN05-1710		1603	1570	1310	2227	1300	1100	1641
iC7-60SAIN05-1760	3 x IM11/ IR11	1787	1750	1470	2499	1500	1200	1892
iC7-60SAIN05-1960		1940	1900	1580	2686	1600	1300	2021
iC7-60SAIN05-2150		2083	2040	1700	2890	1700	1300	2146
iC7-60SAIN05-2510		2389	2340	1950	3315	1900	1600	2397

Table 58: Current Ratings for Inverter Module, UL 460 V AC (650–740 V DC) (continued)

Model code	Frame	AC current				Typical motor power, 460 V AC		DC current I _{N-DC} [A]
		I _N [A]	I _L [A]	I _H [A]	I _{peak} [A]	P _L [Hp]	P _H [Hp]	
iC7-60SAIN05-2640	4 x IM11/ IR11	2532	2480	2060	3502	2100	1700	2650
iC7-60SAIN05-2880		2685	2630	2190	3723	2200	1800	2775
iC7-60SAIN05-3280		3114	3050	2540	4318	2500	2100	3155
iC7-60SAIN05-3600	5 x IM11/ IR11	3573	3500	2910	4947	2900	2300	3658
iC7-60SAIN05-4060		3859	3780	3140	5338	3200	2500	4036
iC7-60SAIN05-4320	6 x IM11/ IR11	4176	4090	3400	5780	3400	2700	4289
iC7-60SAIN05-4870		4625	4530	3760	6392	3700	2900	4667

10.6.10 Current Ratings for Inverter Module, 500 V AC (650–740 V DC)

Table 59: Current Ratings for Inverter Module, 500 V AC (650–740 V DC)

Model code	Frame	AC current				Typical motor power, 500 V AC		DC current I _{N-DC} [A]
		I _N [A]	I _L [A]	I _H [A]	I _{peak} [A]	P _L [kW]	P _H [kW]	
iC7-60SAIN05-385A	IM10/IR10	394	385	320	544	250	200	408
iC7-60SAIN05-480A		490	480	399	679	315	250	513
iC7-60SAIN05-590A		543	531	441	750	355	250	577
iC7-60SAIN05-658A	IM11/IR11	603	590	490	833	400	315	651
iC7-60SAIN05-730A		672	658	547	930	450	355	731
iC7-60SAIN05-820A		746	730	606	1031	500	400	812
iC7-60SAIN05-880A		838	820	681	1158	560	450	910
iC7-60SAIN05-1000	2 x IM10/ IR10	940	920	764	1299	630	500	1024
iC7-60SAIN05-1100		1052	1030	855	1454	710	560	1153
iC7-60SAIN05-1260	2 x IM11/ IR11	1174	1150	960	1632	800	630	1300
iC7-60SAIN05-1450		1328	1300	1080	1836	900	710	1461
iC7-60SAIN05-1710		1603	1570	1310	2227	1100	900	1787
iC7-60SAIN05-1760	3 x IM11/ IR11	1787	1750	1470	2499	1200	1000	1949
iC7-60SAIN05-1960		1940	1900	1580	2686	1300	1100	2112
iC7-60SAIN05-2150		2083	2040	1700	2890	1400	1100	2273
iC7-60SAIN05-2510		2389	2340	1950	3315	1600	1300	2598
iC7-60SAIN05-2640	4 x IM11/ IR11	2532	2480	2060	3502	1700	1400	2760
iC7-60SAIN05-2880		2685	2630	2190	3723	1800	1500	2922
iC7-60SAIN05-3280		3114	3050	2540	4318	2000	1700	3246
iC7-60SAIN05-3600	5 x IM11/ IR11	3573	3500	2910	4947	2400	1900	3897
iC7-60SAIN05-4060		3859	3780	3140	5338	2600	2100	4221

Table 59: Current Ratings for Inverter Module, 500 V AC (650–740 V DC) (continued)

Model code	Frame	AC current				Typical motor power, 500 V AC		DC current
		I_N [A]	I_L [A]	I_H [A]	I_{peak} [A]	P_L [kW]	P_H [kW]	
iC7-60SAIN05-4320	6 x IM11/ IR11	4176	4090	3400	5780	2800	2300	4546
iC7-60SAIN05-4870		4625	4530	3760	6392	3100	2600	5033

10.6.11 Current Ratings for Grid Converter Module, 400 V AC (465–650 V DC)

Table 60: Current Ratings for Grid Converter Module, 400 V AC (465–650 V DC)

Model code	Frame	AC ratings				DC ratings		
		S_L [kVA]	I_N [A]	I_L [A]	I_H [A]	I_{N-DC} [A]	P_{L-DC} [kW]	P_{H-DC} [kW]
iC7-60SAGC05-317A	AM10/ AR10	220	324	317	263	371	216	179
iC7-60SAGC05-400A		278	409	400	327	469	272	223
iC7-60SAGC05-514A		357	525	514	426	602	349	290
iC7-60SAGC05-580A	AM11/ AR11	402	593	580	464	677	394	316
iC7-60SAGC05-650A		451	664	650	525	760	442	357
iC7-60SAGC05-730A		506	746	730	591	852	496	402
iC7-60SAGC05-816A		566	833	816	678	953	555	461
iC7-60SAGC05-920A	2 x AM10/ AR10	638	940	920	735	1075	625	500
iC7-60SAGC05-1030		714	1052	1030	850	1203	700	578
iC7-60SAGC05-1210	2 x AM11/ AR11	839	1236	1210	980	1413	822	666
iC7-60SAGC05-1410		977	1440	1410	1140	1647	958	775
iC7-60SAGC05-1630		1130	1664	1630	1360	1903	1107	924
iC7-60SAGC05-1860	3 x AM11/ AR11	1289	1899	1860	1575	2172	1263	1070
iC7-60SAGC05-2120		1469	2165	2120	1838	2475	1440	1248
iC7-60SAGC05-2450		1698	2501	2450	2030	2861	1664	1379
iC7-60SAGC05-2800	4 x AM11/ AR11	1940	2859	2800	2231	3268	1902	1515
iC7-60SAGC05-3270		2266	3338	3270	2710	3817	2221	1840
iC7-60SAGC05-3650	5 x AM11/ AR11	2529	3726	3650	2888	4260	2479	1961
iC7-60SAGC05-4080		2827	4165	4080	3390	4761	2771	2302
iC7-60SAGC05-4500	6 x AM11/ AR11	3118	4594	4500	3544	5251	3056	2407
iC7-60SAGC05-4900		3395	5002	4900	4070	5719	3327	2764

10.6.12 Current Ratings for Grid Converter Module, 500 V AC (650–740 V DC)

Table 61: Current Ratings for Grid Converter Module, 500 V AC (650–740 V DC)

Model code	Frame	AC ratings				DC ratings		
		S_L [kVA]	I_N [A]	I_L [A]	I_H [A]	I_{N-DC} [A]	P_{L-DC} [kW]	P_{H-DC} [kW]
iC7-60SAGC05-317A	AM10/AR10	268	316	309	256	361	263	218
iC7-60SAGC05-400A		330	388	380	298	445	323	253
iC7-60SAGC05-514A		401	473	463	385	542	393	327
iC7-60SAGC05-580A	AM11/AR11	451	531	520	424	608	442	360
iC7-60SAGC05-650A		507	598	585	470	683	497	399
iC7-60SAGC05-730A		563	664	650	511	760	552	434
iC7-60SAGC05-816A		634	747	731	607	854	621	516
iC7-60SAGC05-920A	2 x AM10/ AR10	715	843	825	639	963	701	543
iC7-60SAGC05-1030		806	950	930	770	1086	790	654
iC7-60SAGC05-1210	2 x AM11/ AR11	936	1103	1080	880	1261	917	747
iC7-60SAGC05-1410		1083	1276	1250	1030	1459	1061	875
iC7-60SAGC05-1630		1265	1491	1460	1210	1704	1240	1027
iC7-60SAGC05-1860	3 x AM11/ AR11	1447	1705	1670	1363	1949	1418	1157
iC7-60SAGC05-2120		1655	1950	1910	1533	2229	1622	1302
iC7-60SAGC05-2450		1897	2236	2190	1820	2557	1859	1545
iC7-60SAGC05-2800	4 x AM11/ AR11	2174	2563	2510	1874	2930	2131	1591
iC7-60SAGC05-3270		2529	2981	2920	2430	3408	2479	2063
iC7-60SAGC05-3650	5 x AM11/ AR11	2850	3359	3290	2726	3840	2793	2314
iC7-60SAGC05-4080		3161	3726	3650	3030	4260	3098	2572
iC7-60SAGC05-4500	6 x AM11/ AR11	3473	4094	4010	3152	4681	3404	2676
iC7-60SAGC05-4900		3802	4482	4390	3640	5124	3726	3090

10.7 Derating the Output Current

The output current must be derated in the following cases.

- When the ambient temperature is above 40 °C (104 °F).
- When the installation altitude is higher than 1000 m (3300 ft).
- For INU modules, derating is required when the switching frequency is higher than 3 kHz. The default switching frequency for AFE/ GC modules is 4 kHz.

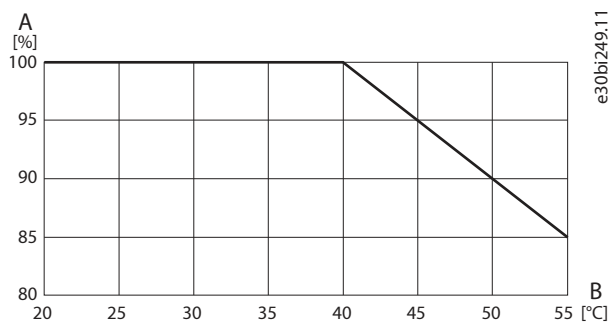

Figure 123: Output Current Derating vs. Ambient Temperature

A	Allowed output current	B	Ambient temperature
----------	------------------------	----------	---------------------

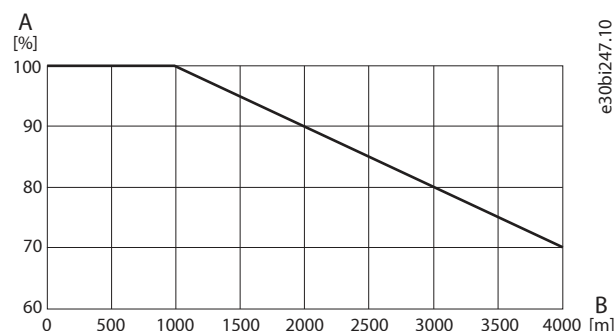

Figure 124: Output Current Derating vs. Installation Altitude

A	Allowed output current	B	Installation altitude, above sea level
----------	------------------------	----------	--

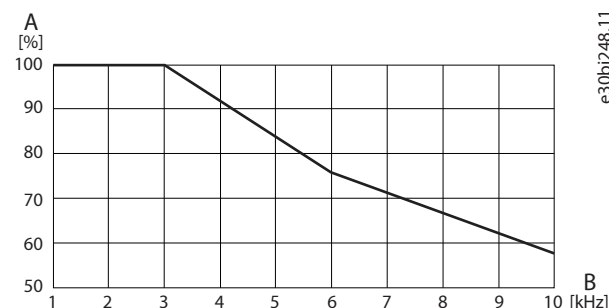

Figure 125: Output Current Derating vs. Switching Frequency (INU)

A	Allowed output current	B	Switching frequency
----------	------------------------	----------	---------------------

10.8 Power Losses

10.8.1 General Power Loss Information

The power loss values have been calculated in worst-case scenarios. Use MyDrive EcoSmart for case-specific power losses.

The power loss tables for the air-cooled system modules can be found with these links.

- [10.8.2 Power Losses of AFE Modules without Options, 380–440 V](#)
- [10.8.3 Power Losses of AFE Modules without Options, 440–500 V](#)
- [10.8.4 Power Losses of LCL Filter at Drive Nominal Parameters, 380–500 V](#)
- [10.8.5 Power Losses of Inverter Modules without Options, 380–440 V](#)
- [10.8.6 Power Losses of Inverter Modules with dU/dt Filter, 150 m \(492 ft\) Motor Cables, 380–440 V](#)

- [10.8.7 Power Losses of Inverter Modules without Options, 440–500 V](#)
- [10.8.8 Power Losses of Inverter Modules with dU/dt Filter, 150 m \(492 ft\) Motor Cables, 440–500 V](#)

10.8.2 Power Losses of AFE Modules without Options, 380–440 V

The specifications for the values in the table

- Active front-end module
- 380–440 V AC (465–740 V DC)
- Losses calculated with 400 V AC and 594 V DC
- No input filters
- Switching frequency 4 kHz
- NSPWM modulator

Table 62: Power Losses of AFE Modules without Options, 380–440 V

Model code ⁽¹⁾	Frame	Rated current I_L [A]	4 kHz	
			Total power losses [kW]	Main cooling channel power losses [W]
iC7-60SA3A05-317A	AM10	317	2.1	1.9
iC7-60SA3A05-400A		400	2.7	2.5
iC7-60SA3A05-514A		514	3.9	3.5
iC7-60SA3A05-580A	AM11	580	3.8	3.5
iC7-60SA3A05-650A		650	4.5	4.1
iC7-60SA3A05-730A		730	5.2	4.8
iC7-60SA3A05-816A		816	6.2	5.7
iC7-60SA3A05-920A	2 x AM10	920	6.6	5.9
iC7-60SA3A05-1030		1030	7.8	7.1
iC7-60SA3A05-1210	2 x AM11	1210	8.1	7.4
iC7-60SA3A05-1410		1410	10.0	9.1
iC7-60SA3A05-1630		1630	12.4	11.3
iC7-60SA3A05-1860	3 x AM11	1860	12.7	11.5
iC7-60SA3A05-2120		2120	15.1	13.7
iC7-60SA3A05-2450		2450	18.7	17.0
iC7-60SA3A05-2800	4 x AM11	2800	19.9	18.1
iC7-60SA3A05-3270		3270	24.9	22.7
iC7-60SA3A05-3650	5 x AM11	3650	26.2	23.8
iC7-60SA3A05-4080		4080	31.1	28.3
iC7-60SA3A05-4500	6 x AM11	4500	33.0	30.0
iC7-60SA3A05-4900		4900	37.4	33.9

1) Model codes starting with iC7-60SA3A05 or iC7-60SA3H05

10.8.3 Power Losses of AFE Modules without Options, 440–500 V

The specifications for the values in the table

- Active front-end module
- 440–500 V AC (465–740 V DC)
- Losses calculated with 500 V AC and 740 V DC
- No input filters
- Switching frequency 4 kHz
- NSPWM modulator

Table 63: Power Losses of AFE Modules without Options, 441–500 V

Model code ⁽¹⁾	Frame	Rated current I_L [A]	4 kHz	
			Total power losses [kW]	Main cooling channel power losses [W]
iC7-60SA3A05-317A	AM10	309	2.2	2.1
iC7-60SA3A05-400A		380	2.9	2.6
iC7-60SA3A05-514A		463	3.8	3.5
iC7-60SA3A05-580A	AM11	520	3.7	3.4
iC7-60SA3A05-650A		585	4.4	4.0
iC7-60SA3A05-730A		650	5.0	4.6
iC7-60SA3A05-816A		731	5.9	5.5
iC7-60SA3A05-920A	2 x AM10	825	6.4	5.8
iC7-60SA3A05-1030		930	7.6	7.0
iC7-60SA3A05-1210	2 x AM11	1080	7.8	7.2
iC7-60SA3A05-1410		1250	9.5	8.7
iC7-60SA3A05-1630		1460	11.8	10.9
iC7-60SA3A05-1860	3 x AM11	1670	12.2	11.3
iC7-60SA3A05-2120		1910	14.6	13.4
iC7-60SA3A05-2450		2190	17.8	16.3
iC7-60SA3A05-2800	4 x AM11	2510	19.1	17.6
iC7-60SA3A05-3270		2920	23.7	21.8
iC7-60SA3A05-3650	5 x AM11	3290	25.3	23.2
iC7-60SA3A05-4080		3650	29.6	27.2
iC7-60SA3A05-4500	6 x AM11	4010	31.1	28.6
iC7-60SA3A05-4900		4390	35.6	32.8

1) Model codes starting with iC7-60SA3A05 or iC7-60SA3H05

10.8.4 Power Losses of LCL Filter at Drive Nominal Parameters, 380–500 V

Table 64: Power Losses of LCL Filter, 380–500 V

Protection rating	Frame	Voltage [V]	Rated current [A]	Total power losses [kW]
IP00	LCL10	380–500	514	4.4
IP00 with an IP54 segregated cooling channel		380–500	514	4.4
IP00	LCL11	380–500	816	5.8
IP00 with an IP54 segregated cooling channel		380–500	816	5.0
IP00 with an IP54 segregated cooling channel	LCL11W	380–500	820	5.4

10.8.5 Power Losses of Inverter Modules without Options, 380–440 V

The specifications for the values in the table

- Inverter module
- 380–440 V AC (465–740 V DC)
- Losses calculated with 400 V AC and 594 V DC
- No output filters
- Switching frequency 2 kHz with SVPWM modulator or 3 kHz with DPWM modulator

Table 65: Power Losses of Inverter Modules without Options, 380–440 V

Model code	Frame	Rated current I_L [A]	3 kHz DPWM	
			Total power losses [kW]	Main cooling channel power losses [W]
iC7-60SAIN05-385A	IM10	385	2.3	2.1
iC7-60SAIN05-480A		480	3.1	2.7
iC7-60SAIN05-590A		590	4.3	3.8
iC7-60SAIN05-658A	IM11	658	4.1	3.7
iC7-60SAIN05-730A		730	4.8	4.4
iC7-60SAIN05-820A		820	5.8	5.2
iC7-60SAIN05-880A		880	6.5	5.8
iC7-60SAIN05-1000	2 x IM10	1000	6.5	5.8
iC7-60SAIN05-1100		1100	7.6	6.8
iC7-60SAIN05-1260	2 x IM11	1260	7.7	7.0
iC7-60SAIN05-1450		1450	9.6	8.6
iC7-60SAIN05-1710		1710	12.4	11.2
iC7-60SAIN05-1760	3 x IM11	1760	10.5	9.5
iC7-60SAIN05-1960		1960	12.3	11.1
iC7-60SAIN05-2150		2150	14.1	12.8
iC7-60SAIN05-2510		2510	18.1	16.3

Table 65: Power Losses of Inverter Modules without Options, 380–440 V (continued)

Model code	Frame	Rated current I_L [A]	3 kHz DPWM	
			Total power losses [kW]	Main cooling channel power losses [W]
iC7-60SAIN05-2640	4 x IM11	2640	16.6	15.0
iC7-60SAIN05-2880		2880	19.0	17.1
iC7-60SAIN05-3280		3280	23.2	20.9
iC7-60SAIN05-3600	5 x IM11	3600	23.7	21.4
iC7-60SAIN05-4060		4060	28.4	25.6
iC7-60SAIN05-4320	6 x IM11	4320	28.5	25.7
iC7-60SAIN05-4870		4870	34.1	30.7

10.8.6 Power Losses of Inverter Modules with dU/dt Filter, 150 m (492 ft) Motor Cables, 380–440 V

The specifications for the values in the table

- Inverter module
- 380–440 V AC (465–740 V DC)
- Losses calculated with 400 V AC and 594 V DC
- With dU/dt filter
- Switching frequency 3 kHz
- DPWM modulator
- Motor cable length is a maximum of 150 m (492 ft)

Table 66: Power Losses of Inverter Modules with dU/dt Filter, 150 m (492 ft) Motor Cables, 380–440 V

Model code	Frame	Rated current I_L [A]	3 kHz DPWM	
			Total power losses [kW]	Main cooling channel power losses [W]
iC7-60SAIN05-385A	IR10	385	2.9	2.6
iC7-60SAIN05-480A		480	3.8	3.4
iC7-60SAIN05-590A		590	5.1	4.7
iC7-60SAIN05-658A	IR11	658	5.1	4.7
iC7-60SAIN05-730A		730	5.9	5.4
iC7-60SAIN05-820A		820	7.0	6.5
iC7-60SAIN05-880A		880	7.8	7.2
iC7-60SAIN05-1000	2 x IR10	1000	8.0	7.3
iC7-60SAIN05-1100		1100	9.2	8.4
iC7-60SAIN05-1260	2 x IR11	1260	9.6	8.9
iC7-60SAIN05-1450		1450	11.7	10.8
iC7-60SAIN05-1710		1710	15.1	13.8

Table 66: Power Losses of Inverter Modules with dU/dt Filter, 150 m (492 ft) Motor Cables, 380–440 V (continued)

Model code	Frame	Rated current I_L [A]	3 kHz DPWM	
			Total power losses [kW]	Main cooling channel power losses [W]
iC7-60SAIN05-1760	3 x IR11	1760	13.1	12.1
iC7-60SAIN05-1960		1960	15.2	14.0
iC7-60SAIN05-2150		2150	17.3	15.9
iC7-60SAIN05-2510		2510	21.9	20.2
iC7-60SAIN05-2640	4 x IR11	2640	20.5	18.9
iC7-60SAIN05-2880		2880	23.2	21.4
iC7-60SAIN05-3280		3280	28.2	25.9
iC7-60SAIN05-3600	5 x IR11	3600	29.0	26.7
iC7-60SAIN05-4060		4060	34.5	31.7
iC7-60SAIN05-4320	6 x IR11	4320	34.9	32.1
iC7-60SAIN05-4870		4870	41.4	38.0

10.8.7 Power Losses of Inverter Modules without Options, 440–500 V

The specifications for the values in the table

- Inverter module
- 440–500 V AC (465–740 V DC)
- Losses calculated with 500 V AC and 740 V DC
- No output filters
- Switching frequency 2 kHz with SVPWM modulator or 3 kHz with DPWM modulator

Table 67: Power Losses of Inverter Modules without Options, 440–500 V

Model code	Frame	Rated current I_L [A]	3 kHz DPWM	
			Total power losses [kW]	Main cooling channel power losses [W]
iC7-60SAIN05-385A	IM10	385	2.5	2.3
iC7-60SAIN05-480A		480	3.4	3.1
iC7-60SAIN05-590A		531	4.0	3.6
iC7-60SAIN05-658A	IM11	590	3.9	3.5
iC7-60SAIN05-730A		658	4.5	4.1
iC7-60SAIN05-820A		730	5.2	4.8
iC7-60SAIN05-880A		820	6.3	5.7
iC7-60SAIN05-1000	2 x IM10	920	6.4	5.8
iC7-60SAIN05-1100		1030	7.7	7.0

Table 67: Power Losses of Inverter Modules without Options, 440–500 V (continued)

Model code	Frame	Rated current I_L [A]	3 kHz DPWM	
			Total power losses [kW]	Main cooling channel power losses [W]
iC7-60SAIN05-1260	2 x IM11	1150	7.4	6.7
iC7-60SAIN05-1450		1300	8.9	8.1
iC7-60SAIN05-1710		1570	11.9	10.9
iC7-60SAIN05-1760	3 x IM11	1750	11.4	10.3
iC7-60SAIN05-1960		1900	12.9	11.7
iC7-60SAIN05-2150		2040	14.3	13.0
iC7-60SAIN05-2510		2340	17.7	16.2
iC7-60SAIN05-2640	4 x IM11	2480	16.7	15.2
iC7-60SAIN05-2880		2630	18.2	16.6
iC7-60SAIN05-3280		3050	22.6	20.6
iC7-60SAIN05-3600	5 x IM11	3500	24.7	22.5
iC7-60SAIN05-4060		3780	27.8	25.3
iC7-60SAIN05-4320	6 x IM11	4090	28.6	26.1
iC7-60SAIN05-4870		4530	33.3	30.3

10.8.8 Power Losses of Inverter Modules with dU/dt Filter, 150 m (492 ft) Motor Cables, 440–500 V

The specifications for the values in the table

- Inverter module
- 440–500 V AC (465–740 V DC)
- Losses calculated with 500 V AC and 740 V DC
- With dU/dt filter
- Switching frequency 3 kHz
- DPWM modulator
- Motor cable length is a maximum of 150 m (492 ft)

Table 68: Power Losses of Inverter Modules with dU/dt Filter, 150 m (492 ft) Motor Cables, 440–500 V

Model code	Frame	Rated current I_L [A]	3 kHz DPWM	
			Total power losses [kW]	Main cooling channel power losses [W]
iC7-60SAIN05-385A	IR10	385	3.3	3.1
iC7-60SAIN05-480A		480	4.3	4.0
iC7-60SAIN05-590A		531	5.0	4.7

Table 68: Power Losses of Inverter Modules with dU/dt Filter, 150 m (492 ft) Motor Cables, 440–500 V (continued)

Model code	Frame	Rated current I_L [A]	3 kHz DPWM	
			Total power losses [kW]	Main cooling channel power losses [W]
iC7-60SAIN05-658A	IR11	590	5.0	4.6
iC7-60SAIN05-730A		658	5.7	5.3
iC7-60SAIN05-820A		730	6.5	6.1
iC7-60SAIN05-880A		820	7.8	7.2
iC7-60SAIN05-1000	2 x IR10	920	8.2	7.6
iC7-60SAIN05-1100		1030	9.7	8.9
iC7-60SAIN05-1260	2 x IR11	1150	9.6	8.9
iC7-60SAIN05-1450		1300	11.3	10.5
iC7-60SAIN05-1710		1570	14.7	13.7
iC7-60SAIN05-1760	3 x IR11	1750	14.6	13.6
iC7-60SAIN05-1960		1900	16.4	15.2
iC7-60SAIN05-2150		2040	18.0	16.7
iC7-60SAIN05-2510		2340	21.9	20.4
iC7-60SAIN05-2640	4 x IR11	2480	21.2	19.8
iC7-60SAIN05-2880		2630	23.0	21.4
iC7-60SAIN05-3280		3050	28.1	26.1
iC7-60SAIN05-3600	5 x IM11	3500	31.0	28.8
iC7-60SAIN05-4060		3780	34.6	32.1
iC7-60SAIN05-4320	6 x IM11	4090	36.0	33.4
iC7-60SAIN05-4870		4530	41.4	38.4

10.9 Technical Data

Table 69: Mains Connection, AFE/GC Modules

Technical item or function	Technical data
Nominal AC voltage	Voltage class 05: 3 x 380–500 V AC (–15%...+10%)
Nominal DC voltage	Voltage class 05: 465–740 V DC
Mains frequency	45–66 Hz
Mains network	TN-S, TN-C, IT and TT. (Supply voltage limited to 500 V AC for corner-grounded networks.)
Displacement power factor (DPF)	AFE: 1
Total harmonics distortion THDi (nominal situation and undistorted network)	AFE: <5% (Voltage class 05)
Short-circuit current rating, with the specified fuses or circuit breakers	The maximum short-circuit current $I_{cc} \leq 100$ kA

Table 69: Mains Connection, AFE/GC Modules (continued)

Technical item or function	Technical data
Overvoltage category according to IEC 61800-5-1	Category III
Voltage imbalance	AFE: $\pm 3\%$

Table 70: Motor Connection, INU Modules

Technical item or function	Technical data
Output voltage	0–400/460/500 V
Nominal DC voltage	Voltage class 05: 465–740 V DC
Output frequency	0–599 Hz
Switching frequency	INU: 1.5–10 kHz DPWM, default 3 kHz DPWM AFE/GC: 4 kHz
Field weakening point	1–600 Hz
Motor control principles	U/f control VVC+ (Vector Voltage Control) FVC+ (Flux Vector Control)
Motor and generator types supported	Induction/asynchronous motor Non-salient permanent magnet motor
Torque control, torque step rise time	Open loop: <5 ms with nominal torque and <1 ms with nominal torque with AFE supply Closed loop: <5 ms with nominal torque and <1 ms with nominal torque with AFE supply
Torque control, static accuracy	Open loop: <2% of motor nominal torque up to nominal speed and <4% of motor nominal torque in the field weakening area Closed loop: <2% of motor nominal torque up to nominal speed and <4% of motor nominal torque in the field weakening area
Speed control, static accuracy	Open loop: 5% of motor nominal slip up to motor nominal motor frequency and 10% of motor nominal slip in the field weakening area Closed loop: 0.01% static error of nominal speed with encoder PPR of 1024 or better
Speed control, dynamic accuracy (response)	Open loop: 0.2–0.4 s with nominal torque step Closed loop: 0.1–0.2 s with nominal torque step
Motor control resolution	Reference setpoint resolution 31 bit + sign
Cable length	Up to 150 m (492 ft) symmetrical and shielded motor cable

Table 71: Control Electronic Connection

Technical item or function	Technical data
Input voltage U_{in}	24 V DC +15/-10%, power consumption is 15–60 W depending on configuration. Ground = negative polarity floating (potentially balanced (1 M Ω) against chassis)

Table 72: DC Link

Technical item or function	Technical data
Power unit capacitance	IM10, IR10, AM10, AR10: 13.2 mF IM11, IR11, AM11, AR11: 20.8 mF

Table 73: Ambient Conditions

Technical item or function	Technical data
Protection rating	IP00/NEMA/UL Open Type
Ambient operating temperature	-15 °C...0 °C (5 °F...32 °F) (no frost). The highest current rating of AM11 and IM11 must be derated 20% in freezing conditions. 0 °C...+40 °C (32 °F...104 °F) (at I _N) with derating up to +55 °C (131 °F).
Installation temperature	-10 °C...+70 °C (14 °F...158 °F)
Storage/transportation temperature	-40 °C...+70 °C (-40 °F...158 °F)
Relative humidity	5–95% RH, no condensation, no dripping water
Environmental conditions storage	(IEC 60721-3-1:2018) Climatic conditions: Class 1K21 Chemically active substances: Class 1C2 Biological conditions: Class 1B1 Mechanical conditions: Class 1M11 Mechanically active substances: Class 1S12
Environmental conditions transportation	(IEC 60721-3-2:2018) Climatic conditions: Class 2K11 Chemically active substances: Class 2C2 Biological conditions: Class 2B1 Mechanical conditions: Class 2M5 Mechanically active substances: Class 2S5
Environmental conditions operation	(IEC 60721-3-3:2019) Climatic conditions: Class 3K22 Chemically active substances: Class C4 (ISO 9223:2012) ⁽¹⁾ Biological conditions: Class 3B1 Mechanically active substances: Class 3S6 Special climatic conditions (heat radiation): Class 3Z1
Pollution degree	PD2
Altitude	0–4000 m (0–13100 ft) above sea level: in case the network is not corner-grounded (Voltage class 05). Above 1000 m (3300 ft): derating of the output current by 1% per each 100 m (330 ft) is required.
Vibration (IEC60068-2-6)	Testing was performed with these specifications: <ul style="list-style-type: none"> • Frequency range 5–150 Hz • Displacement amplitude ±0.5 mm, 5–22.29 Hz • Constant peak acceleration 10 m/s² (1 g_n), 22.29–150 Hz

Table 73: Ambient Conditions (continued)

Technical item or function	Technical data
Shock (IEC60068-2-27)	Maximum 5 G, 30 ms
Sound pressure level	<ul style="list-style-type: none"> 1 system module in cabinet: max. 80 dB(A) at worst case operation point 2 modules in parallel: +3 dB(A) 3 modules in parallel: +4.8 dB(A) 4 modules in parallel: +6 dB(A) 5 modules in parallel: +7 dB(A) 6 modules in parallel: +7.8 dB(A)
<div style="background-color: yellow; text-align: center; padding: 5px;">  CAUTION </div> <ul style="list-style-type: none"> When acoustic noise level is >70 dB(A), use hearing protection. 	

1) On board level on coated boards.

Table 74: EMC (IEC61800-3)

Technical item or function	Technical data
Immunity	Fulfills IEC/EN 61800-3:2018, 2nd environment
Emissions	380–500 V AC: IEC/EN 61800-3 (2018), category C3, when C3 > 100 A, if the drive is installed according to instructions. See 6.9 Changing the EMC Protection Level in an IT System . All: The drive can be changed to C4 for IT type mains.

Table 75: Protections

Technical item or function	Technical data
Overvoltage trip limit	911 V DC
Undervoltage trip limit	The value depends on mains voltage. Mains voltage 400 V AC: trip limit 334 V DC Mains voltage 500 V AC: trip limit 447 V DC
Ground fault protection	Yes
Mains supervision	Yes
Motor phase supervision	Yes
Overcurrent protection	Yes
Unit overtemperature protection	Yes
Motor overload protection	Yes
Motor stall protection	Yes
Motor underload protection	Yes

Table 76: Product Compliance

Technical item or function ⁽¹⁾	Technical data
Conformity	CE, cULus, RCM, KC, EAC, UA, UKCA.
Safety Standards	IEC/EN 61800-5-1 + A1 IEC/EN 62477-1 + A1 UL 61800-5-1 CSA C22.2 No.274
Functional safety	STO/SS1-t with option +BEF2 <i>See iC7 Series Functional Safety Operating Guide, Air-cooled and Liquid-cooled System Modules.</i>
Marine type approvals	–

1) For detailed information on the approvals and certifications of the product, see the product label.

Table 77: Efficiency

Technical item or function	Technical data
Efficiency	INU >98.5%, AFE+LCL >97.5% at 400–500 V AC

Danfoss Drives Oy
Runsorintie 7
FIN-65380 Vaasa
drives.danfoss.com

.....
Any information, including, but not limited to information on selection of product, its application or use, product design, weight, dimensions, capacity or any other technical data in product manuals, catalog descriptions, advertisements, etc. and whether made available in writing, orally, electronically, online or via download, shall be considered informative, and is only binding if and to the extent, explicit reference is made in a quotation or order confirmation. Danfoss cannot accept any responsibility for possible errors in catalogs, brochures, videos and other material. Danfoss reserves the right to alter its products without notice. This also applies to products ordered but not delivered provided that such alterations can be made without changes to form, fit or function of the product. All trademarks in this material are property of Danfoss A/S or Danfoss group companies. Danfoss and the Danfoss logo are trademarks of Danfoss A/S. All rights reserved.
.....

