

ENGINEERING
TOMORROW



Service Manual

Axial Piston Pumps

DDC20/24



Revision history

Table of revisions

Date	Changed	Rev
December 2024	Update for implement pump assembly	0504
December 2023	Changed document number from 'AX00000135' and 'L1120413' to 'AX152986482107'	0503
August 2019	Added DDC24	0401
August 2017	change charge pump housing	0302
March 2015	add implement pump option	CA
March 2014	Danfoss layout	BA
September 2011	First printing	AA

Contents

Introduction

Overview.....	4
Warranty.....	4
General instructions.....	4
Remove the unit.....	4
Keep it clean.....	4
Lubricate moving parts.....	4
Replace all O-rings and gaskets.....	4
Secure the unit.....	5
Safety Precautions.....	5
Unintended machine movement.....	5
Flammable cleaning solvents.....	5
Fluid under pressure.....	5
Personal safety.....	5

Gauge port locations and installation

Gauge port locations and sizes- with Aux pad.....	6
Gauge port locations and sizes- with Gerotor.....	7
Gauge port locations and sizes- with Implement pump.....	8

Adjustments

Pump adjustment.....	9
Standard Procedures.....	9
Charge pressure relief valve.....	9
High pressure relief valve.....	10
Loop flushing valve.....	11

Troubleshooting

Troubleshooting Overview.....	12
System operating hot.....	12
Transmission operating normally in one direction only.....	12
System noise or vibration.....	12
System will not operate in either direction.....	12
Sluggish system response.....	13

Minor repair

Charge pump.....	14
Implement pump.....	16
Shaft and shaft seal.....	17
High pressure relief valve (HPRV).....	21
Charge pressure relief valve (CPRV).....	22
Loop flushing valve.....	23
Bypass valve.....	24
Optional coupling.....	25

Torque charts

Charge pump fastener and torque chart.....	26
Implement pump fasteners and torque chart.....	26
Gerotor plugs and torque.....	27
Auxiliary pad plug sizes and torque chart.....	28
Implement pump plug sizes and torque chart.....	29

Introduction

Pump service overview

This manual includes information on maintenance, troubleshooting, and minor repair of DDC20/24 pumps.

Performing minor repairs may require removal from the vehicle/machine. Thoroughly clean the unit before beginning maintenance or repair activities. Since dirt and contamination are the greatest enemies of any type of hydraulic equipment, follow cleanliness requirements strictly. This is especially important when changing the system filter and when removing hoses or plumbing.

A worldwide Global Service Partner Network is available for major repairs. Major repairs require the removal of the unit's endcap, which voids the warranty unless done by a Global Service Partner. Danfoss Global Service Partners are trained by the factory and certified on a regular basis. You can locate your nearest Global Service Partner using the distributor locator at www.danfoss.com.

For detailed technical information, refer to the *Technical Information manual*.

Warranty

Performing maintenance, and minor repairs according to the procedures in this manual will not affect your warranty. Major repairs requiring the removal of the units endcap voids the warranty unless completed by a Danfoss Global Service Partner.

General instructions

Remove the unit



Prior to performing major repairs, remove the unit from the vehicle/machine. Chock the wheels on the vehicle or lock the mechanism to inhibit movement. Be aware that hydraulic fluid may be under high pressure and/or hot. Inspect the outside of the pump and fittings for damage. Cap hoses and plug ports after removal to prevent contamination.

Keep it clean



Cleanliness is a primary means of assuring satisfactory pump life, on either new or repaired units. Clean the outside of the pump thoroughly before disassembly. Take care to avoid contamination of the system ports. Cleaning parts using a clean solvent wash and air drying is usually adequate.

As with any precision equipment, keep all parts free of foreign materials and chemicals. Protect all exposed sealing surfaces and open cavities from damage and foreign material. If left unattended, cover the pump with a protective layer of plastic.

Lubricate moving parts



During assembly, coat all moving parts with clean hydraulic fluid. This assures that these parts are lubricated during start-up.

Replace all O-rings and gaskets



Danfoss recommends you replace all O-rings, seals, and gaskets during repair. Lightly lubricate all O-rings with clean petroleum jelly prior to assembly. Grease must be soluble in hydraulic fluid.

Introduction

Secure the unit



For major repair, place the unit in a stable position with the shaft pointing downward. It is necessary to secure the pump while removing and torquing components and fasteners.

Safety Precautions

Always consider safety precautions before beginning a service procedure. Protect yourself and others from injury. Take the following general precautions whenever servicing a hydraulic system.

Unintended machine movement

Warning

Unintended movement of the machine or mechanism may cause injury to the technician or bystanders. To protect against unintended movement, secure the machine or disable/disconnect the mechanism while servicing.

Flammable cleaning solvents

Warning

Some cleaning solvents are flammable. To avoid possible fire, do not use cleaning solvents in an area where a source of ignition may be present.

Fluid under pressure

Warning

Escaping hydraulic fluid under pressure can have sufficient force to penetrate your skin causing serious injury and/or infection. This fluid may also be hot enough to cause burns. Use caution when dealing with hydraulic fluid under pressure. Relieve pressure in the system before removing hoses, fittings, gauges, or components. Never use your hand or any other body part to check for leaks in a pressurized line. Seek medical attention immediately if you are cut by hydraulic fluid.

Personal safety

Warning

Protect yourself from injury. Use proper safety equipment, including safety glasses, at all times.

Gauge port locations and installation

DDC20/24 gauge port locations and sizes- with Aux pad

The following drawing and table show the gauge port locations and gauge sizes needed.

DDC20/24 with aux pad

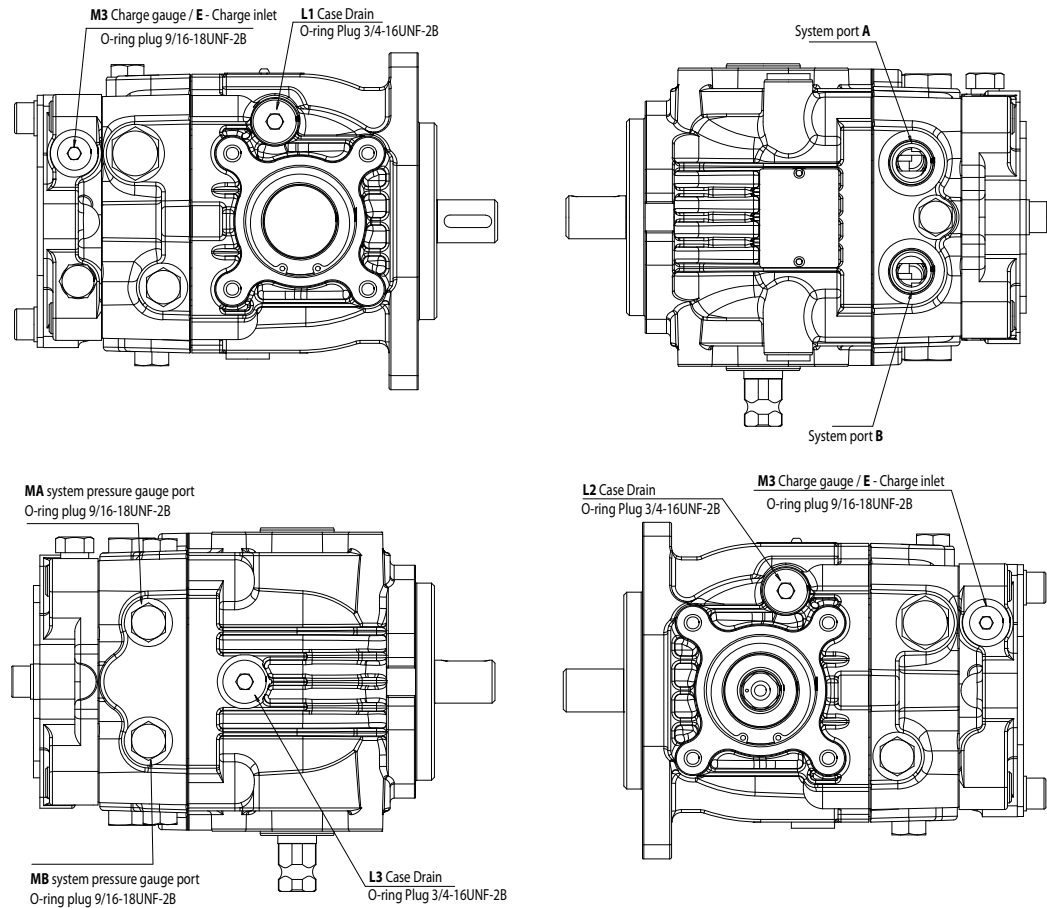

Port Information

Port Identifier	Port Size	Wrench Size	Pressure Obtained	Gauge Size, bar [psi]
L1/L2/L3	3/4-16 UNF	5/16 inch internal hex	Case Drain	10 [100]
MA/MB	9/16-18 UNF	11/16 hex wrench	System Pressure	500 [5000]
M3/E	9/16-18 UNF	1/4 inch internal hex	Charge Pressure	50 [1000]

Gauge port locations and installation

DDC20/24 gauge port locations and sizes- with Gerotor

The following drawing and table show the gauge port locations and gauge sizes needed.

DDC20/24 with gerotor

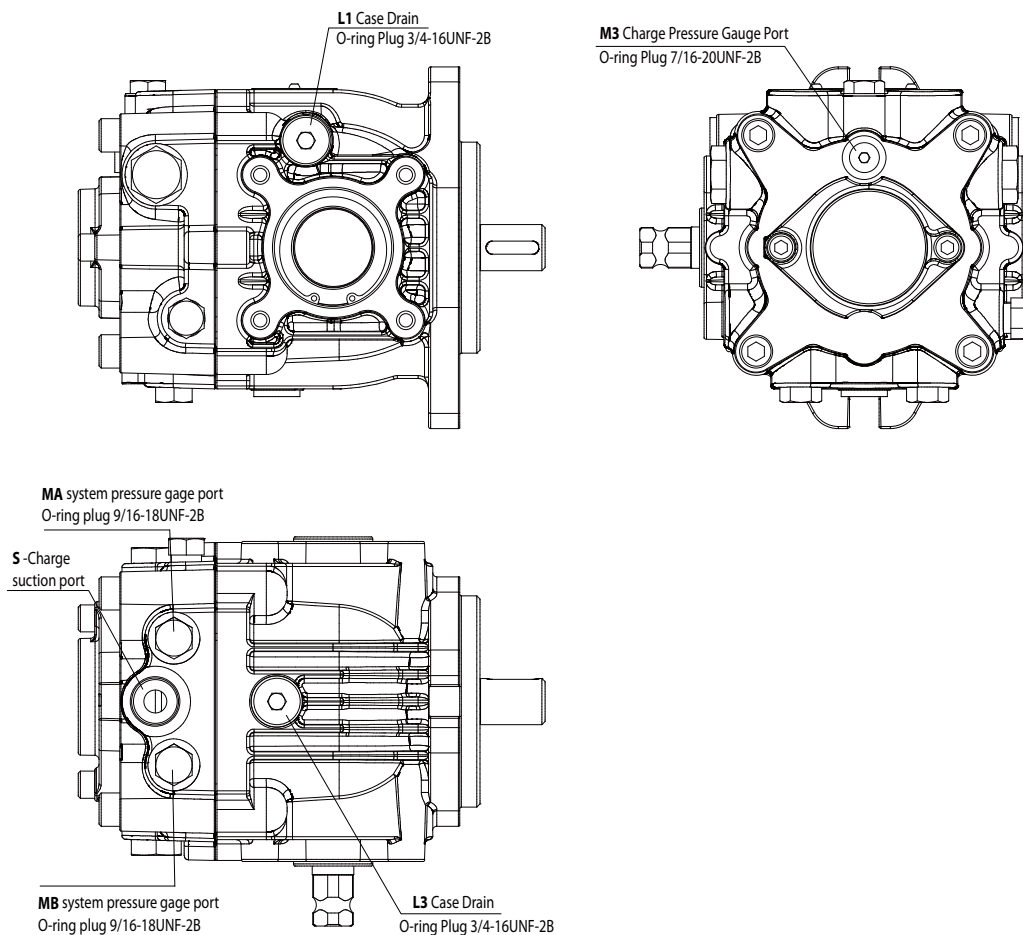

Port Information

Port Identifier	Port Size	Wrench Size	Pressure Obtained	Gauge Size, bar [psi]
L1/L2/L3	3/4-16 UNF	5/16 inch internal hex	Case Drain	10 [100]
MA/MB	9/16-18 UNF	11/16 hex wrench	System Pressure	500 [5000]
S	7/8-14 UNF	N/A (plastic shipping plug)	Charge Inlet	2 [30] Vacuum
M3	7/16-20 UNF	3/16 inch internal hex	Charge Pressure	50 [1000]

Gauge port locations and installation

DDC20/24 gauge port locations and sizes- with implement pump

The following drawing and table show the gauge port locations and gauge sizes needed.

DDC20/24 with implement pump

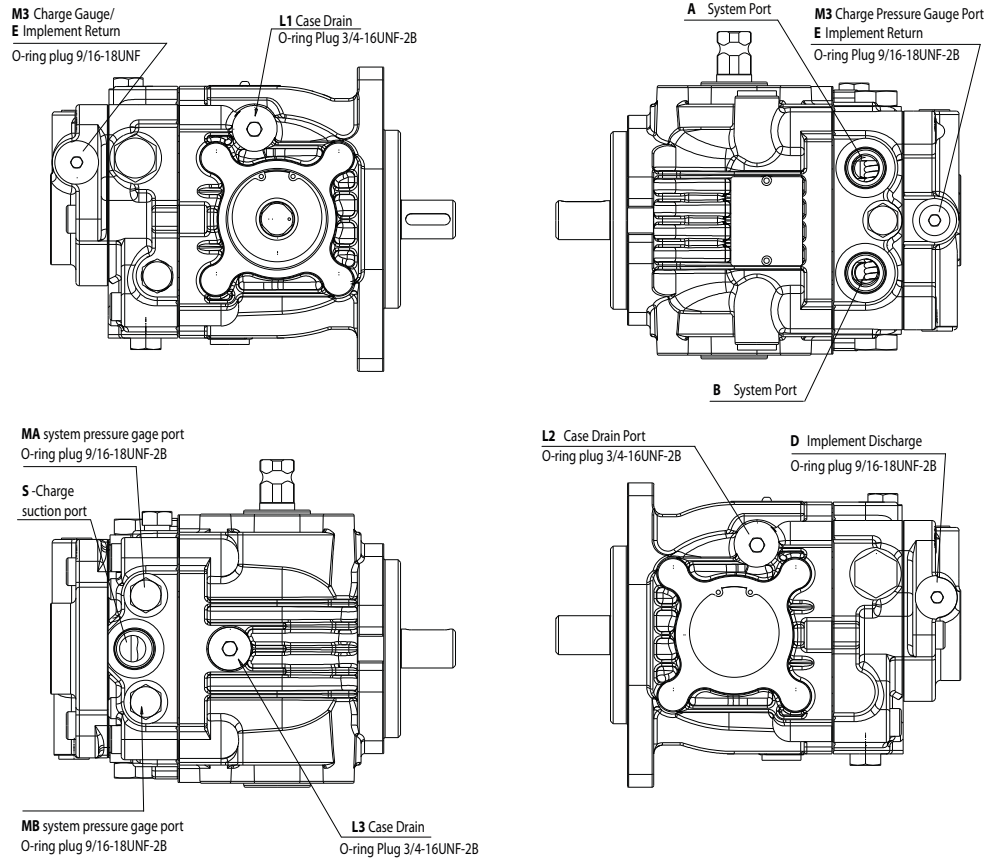

Port Information

Port Identifier	Port Size	Wrench Size	Pressure Obtained	Gauge Size, bar [psi]
L1/L2/L3	3/4-16 UNF	5/16 inch internal hex	Case Drain	10 [100]
MA/MB	9/16-18 UNF	11/16 hex wrench	System Pressure	500 [5000]
S	7/8-14 UNF	N/A (plastic shipping plug)	Charge Inlet	2 [30] Vacuum
D	9/16-18 UNF	1/4 inch internal hex	Implement Pressure	100 [2000]
M3/E	9/16-18 UNF	1/4 inch internal hex	Charge Pressure	50 [1000]

Adjustments

Pump adjustment

This section offers instruction on adjustment of pump components. Read through the entire topic before beginning a service activity. Refer to [Gauge port locations and installation](#) for location of gauge ports and suggested gauge size.

Standard Procedures

! **Caution**

Contamination can damage internal components and void the manufacturer's warranty. Take precautions to ensure system cleanliness when removing and reinstalling system lines

1. With the prime mover off, thoroughly clean the outside of the pump.
2. If removing the pump from the machine, tag each hydraulic line connected to the pump. If hydraulic lines are disconnected, plug each open port, to ensure that dirt and contamination do not get into the pump.
3. Ensure the surrounding areas of the machine are clean and free of contaminants such as dirt and grime.
4. Look at the hydraulic fluid for signs of system contamination, oil discoloration, foam in the oil, sludge, or small metal particles.
5. If there are signs of contamination in the hydraulic fluid, drain the hydraulic system, replace all filters, flush the lines and fill the system with the proper hydraulic fluid.

DDC20/24 charge pressure relief valve adjustment

The following procedure explains how to check for proper operation of the charge pressure relief valve. Charge pressure is the measured pressure minus case drain pressure.

1. Install a 50 bar [1000 psi] pressure gauge at the charge pressure gauge port. Install a 10 bar [100 psi] gauge at one of the case pressure ports. Operate the system with the pump in neutral (zero displacement) when measuring charge pressure.

[Pressure listed in model code assumes a charge flow of 15 l/min \[4 US gal/min\], and are referenced to case pressure. At higher charge flows, the charge pressure will rise over the rated setting.](#)

2. The table shows the acceptable pump charge pressure range for some nominal charge relief valve settings (refer to model code located on serial number plate).
3. If measured pressure is not correct, disassemble the valve and look for signs of wear or contamination. Refer to the [Torque charts](#) chapter for wrench sizes and torque settings.
4. If the valve is worn, replace the entire valve assembly.
5. Re-check the charge pressure setting.

Adjustments

- When the desired charge pressure setting is achieved, remove the gauges.

Charge pressure relief valve

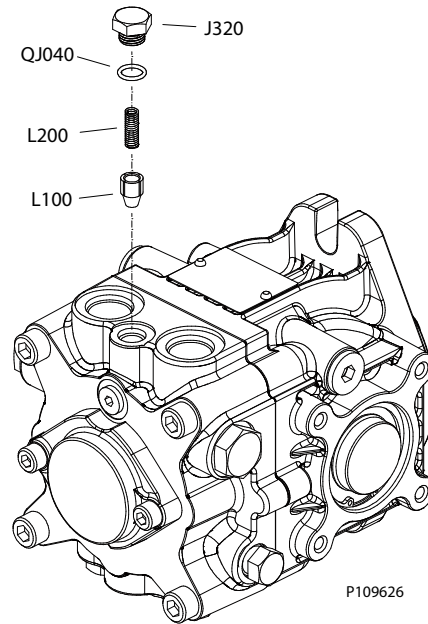

Charge pressure

Model code	Charge pressure ¹
07	7 bar ± 1 bar
18	18 bar ± 1.5 bar

¹ The shown values are calculated by subtracting the case pressure port gauge reading from the charge pressure gauge reading.

Factory set at 1800 min⁻¹ (rpm) with a reservoir temperature of 50° C [120° F].

DDC20/24 high pressure relief valve (HPRV) adjustment

The HPRV valves are set at the factory. No adjustment is possible.

If you suspect a HPRV valve malfunction, replace valve with identical relief setting and test operation of pump. Refer to [Removal](#) for replacement procedures.

When replacing or opening an HPRV, check for proper pump operation by cycling through its full operating range.

Adjustments

HPRV valve locations

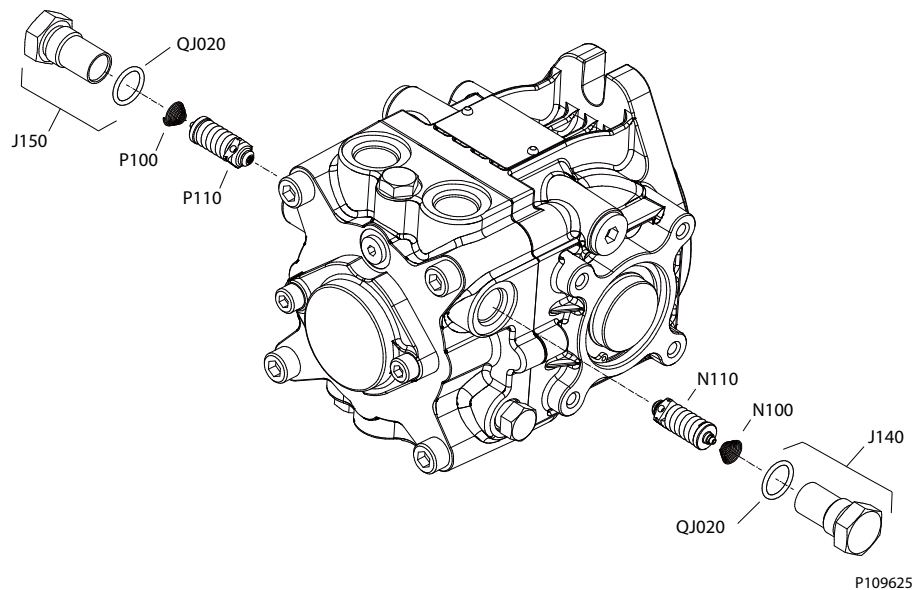

DDC20/24 loop flushing valve adjustment

The loop flushing valve is not adjustable.

If the loop flush valve is malfunctioning, disassemble the valve and check for worn, damaged or scored components. Replace parts if necessary. Refer to [Removal](#) for replacement procedures.

Loop flushing valve locations

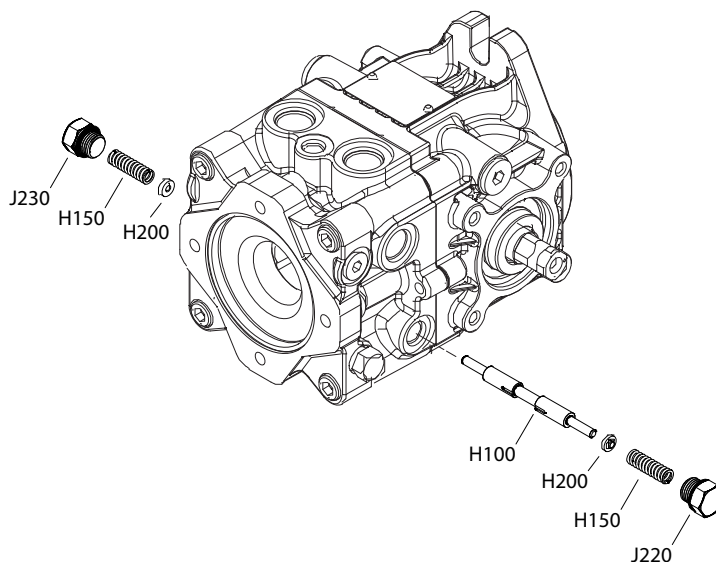

Troubleshooting

Troubleshooting Overview

This section serves as a guide for identifying and resolving undesirable system conditions.

Please observe the safety concerns listed in [Safety Precautions](#) on page 5 and the precautions related to relevant equipment when resolving system issues.

DDC20/24 system operating hot

Cause	Problem	Solution
Oil level in reservoir.	Insufficient hydraulic fluid will not meet cooling demands of system.	Fill reservoir to proper level.
Heat exchanger.	Heat exchanger not sufficiently cooling the system.	Check air flow and input air temperature for heat exchanger. Clean, repair or replace heat exchanger.
Charge pressure.	Low charge pressure will overwork system.	Measure charge pressure. Inspect and/or replace charge relief valve. Inspect charge pump. Repair or replace charge pump.
Charge pump inlet vacuum.	High inlet vacuum will overwork system. A dirty filter will increase the inlet vacuum. Inadequate line size will restrict flow.	Check charge inlet vacuum. If high, inspect inlet filter and replace as necessary. Check for adequate line size, length or other restrictions
System relief pressure settings.	If the system relief valves are worn, contaminated, or valve settings are too low, the relief valves will be overworked.	Verify settings of high pressure relief valves and replace valves as necessary.
System pressure.	Frequent or long term operation over system relief setting will create heat in system	Measure system pressure. If pressure is too high, reduce loads.

DDC20/24 transmission operating normally in one direction only

Cause	Problem	Solution
Control linkage	Control linkage operating improperly	Repair/replace control linkage
High pressure relief valve	Malfunctioning HPRV can affect one direction while the other functions normally.	Exchange the high pressure relief valves. If the problem changes direction, replace the valve that does not operate correctly. Settings may be different for forward/reverse.

DDC20/24 system noise or vibration

Cause	Problem	Solution
Oil level in reservoir	Low oil level leads to cavitation.	Fill reservoir.
Aeration of the oil/ pump inlet vacuum	Air in system decreases efficiency of units and controls. Air in system is indicated by excessive noise in pump, foaming in oil, and hot oil.	Find location where air is entering into the system and fix. Check that inlet line is not restricted and is proper size.
Cold oil	If oil is cold, it may be too viscous for proper function and cause cavitation	Allow the oil to warm up to its normal operating temperature with engine at idle speed.
Pump inlet vacuum	High inlet vacuum causes noise/cavitation.	Check that inlet line is not restricted and is proper size. Check filter and bypass valves (if present).
Shaft couplings	A loose shaft coupling will cause excessive noise.	Replace loose shaft coupling.
Shaft alignment	Misaligned shafts creates noise	Align shafts.
Charge/High pressure relief valves	Unusual noise may indicate sticking valves. Possible contamination.	Clean/replace valves and test pump. May be a normal condition.

DDC20/24 system will not operate in either direction

Cause	Problem	Solution
Oil level in reservoir	Low oil level leads to cavitation.	Fill reservoir.
Open bypass valve	If bypass valve is open, the system loop will be depressurized.	Close bypass valve.

Troubleshooting

Cause	Problem	Solution
Low charge pressure with pump in neutral	Low charge pressure insufficient to recharge system loop	Measure charge pressure with the pump in neutral. If pressure is low, go to Pump charge relief valve
Low charge pressure with pump in stroke	Low charge pressure resulting from elevated loop leakage.	Isolate pump from motor by blocking system ports. With pump in partial stroke and engaged for only a few seconds, check pump charge pressure. Low charge pressure indicates a malfunctioning pump. Continue to next step. Good charge pressure indicates a malfunctioning motor or other system component. Check motor charge relief operation (if present).
Pump charge relief valve.	A pump charge relief valve that is leaky, or contaminated, or set too low will depressurize the system.	Replace pump charge relief valve as necessary
Charge pump inlet filter.	A clogged filter will under supply system loop.	Inspect filter and replace if necessary.
Charge pump.	A malfunctioning charge pump will provide insufficient charge flow.	Repair or replace the charge pump.
System pressure	Low system pressure does not provide enough power to move load	Measure system pressure. Continue to next step.
High pressure relief valves	Defective high pressure relief valves cause system pressure to be low	Replace high pressure relief valves.
Control Linkage	Linkage operating improperly	Repair/replace control linkage

DDC20/24 sluggish system response

Cause	Problem	Solution
Oil level in reservoir	Low oil level causes slower system response	Fill reservoir
High pressure relief valves	Incorrect system pressures will affect system reaction time. High pressure relief valve with orifice may affect system reaction time.	Replace high pressure relief valves
Low prime mover speed	Low engine speed will reduce system performance	Adjust engine speed
Air in system	Air in system will produce slower system response	Fill tank to proper level. Cycle system slowly for several minutes to remove air from system
Pump inlet vacuum	Inlet vacuum is too high resulting in reduced system pressure.	Measure charge inlet vacuum. Inspect line for proper sizing. Replace filter. Confirm proper bypass operation.
Bypass valve	Slightly activated bypass valve will cause cross port leakage.	Verify that the bypass valve is closed and that the valve is seating properly. Clean, repair, or replace it as necessary.

Minor repair

Charge pump

DDC20/24 charge pump disassembly

Charge pump cover orientation

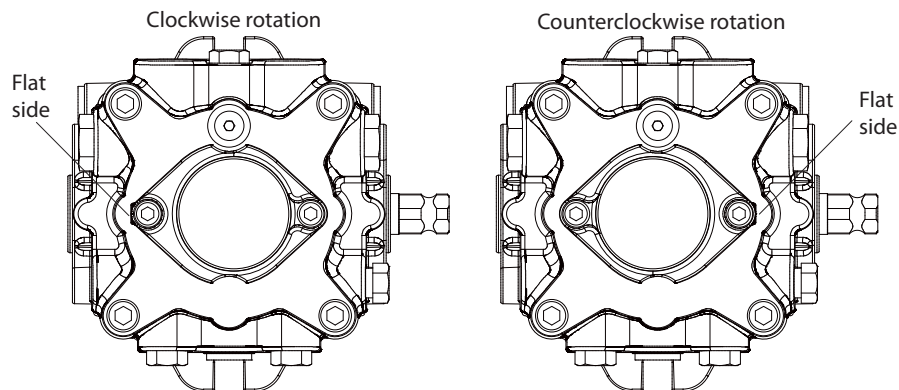

P109624

Please note the orientation of the charge pump during disassembly (clockwise and counterclockwise).

1. Position the pump with the shaft end pointing down.
2. Mark the orientation of the charge pump cover on the endcap for proper reassembly.
3. Remove cap screws (K200). Remove the charge pump cover (K150).
4. Remove and discard O-ring (K100).
5. Remove gerotor (K010). Push out the drive pin (K050).

DDC20/24 charge pump, implement pump and gerotor inspection

Inspect all machined surfaces for wear or damage. If any nicks, scratches or wear are found replace the cover and/or gerotor.

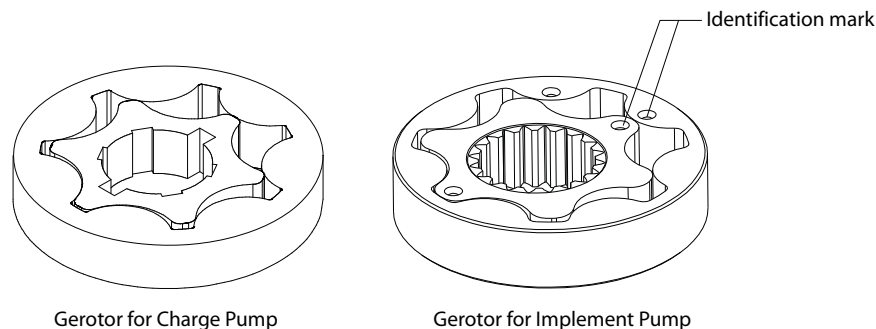

DDC20/24 charge pump assembly

1. Install drive pin (K050) into the shaft.
2. Lubricate and install the gerotor (K010).
3. Lubricate and install O-ring into cover (K100).
4. Install the housing in its original position (K150).
5. Install screws (K200). Torque screws per table.

Minor repair

DDC20/24 Remove charge pump

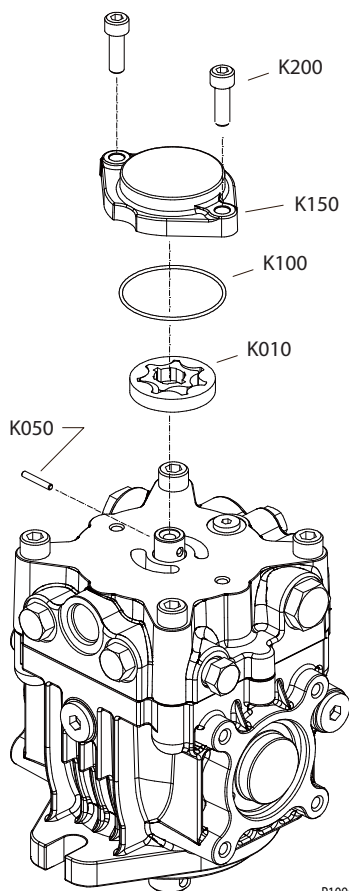

Charge pump cover mounting bolts

Item	Wrench size	Torque
K200	6 mm internal hex	20 N·m [15 lbf·ft]

Minor repair

Implement pump

DDC20/24 implement pump removal

1. Position the pump with the shaft end pointing down.
2. Remove cap screws (K200/K210). Remove the implement pump housing (K150).
3. Remove and discard O-ring (K100/K110).
4. Remove gerotor (K010). Remove locating pins (K250) from housing.

Remove implement pump

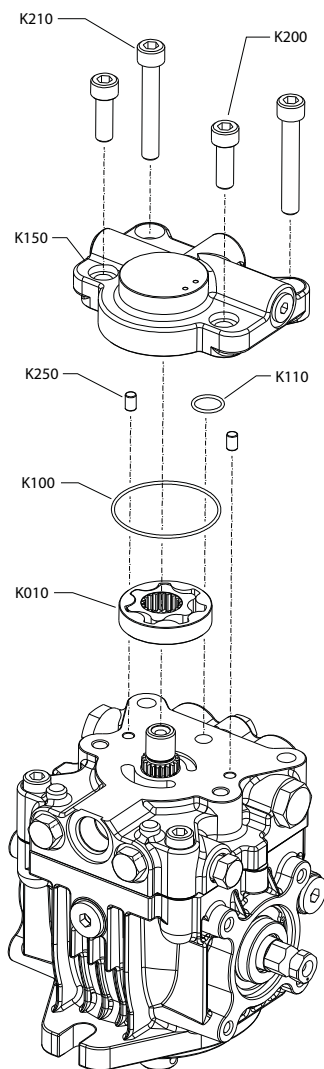

Implement pump cover bolts

Item	Description	Wrench size	Torque
K200	Cap screw	8 mm internal hex	60 N·m [44 lbf·ft]
K210	Cap screw	8 mm internal hex	39 N·m [29 lbf·ft]

Minor repair

DDC20/24 charge pump, implement pump and gerotor inspection

Inspect all machined surfaces for wear or damage. If any nicks, scratches or wear are found replace the housing and/or gerotor.

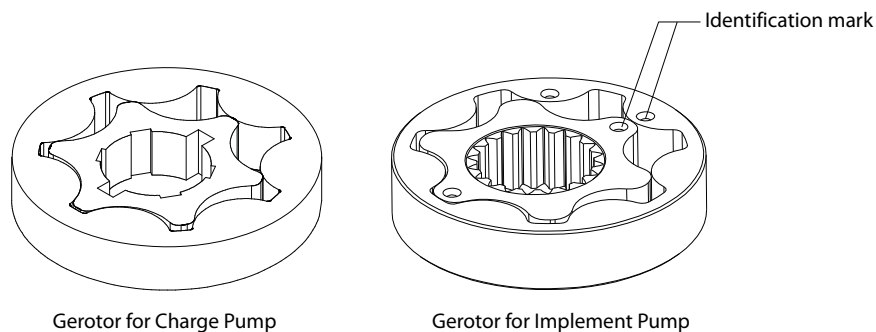

DDC20/24 implement pump assembly

1. Install locating pins (K250) into the endcap.
2. Lubricate and install gerotor (K010). When installing the gerotor (K010) for implement pump, make sure the identification marks are on the same side.
3. Lubricate and install O-ring (K100/K110) into housing (K150).
4. Install housing (K150).
5. Install screws (K200/K210). Torque screws per table.

Shaft and shaft seal

DDC20/24 shaft seal removal

1. Orient pump with the shaft pointing up.
2. Using a retaining ring pliers, remove retaining ring (F125).
3. Remove the shaft seal (F120) and discard.

! Caution

Do not damage the housing bore, shaft or bearing when removing the shaft and shaft seal.

Carefully drive a small sheet-metal screw into the shaft seal to facilitate removal. Be careful not to damage the bearing below the seal. Attach a slide hammer or appropriate puller to the screw head and pull to remove the seal.

Minor repair

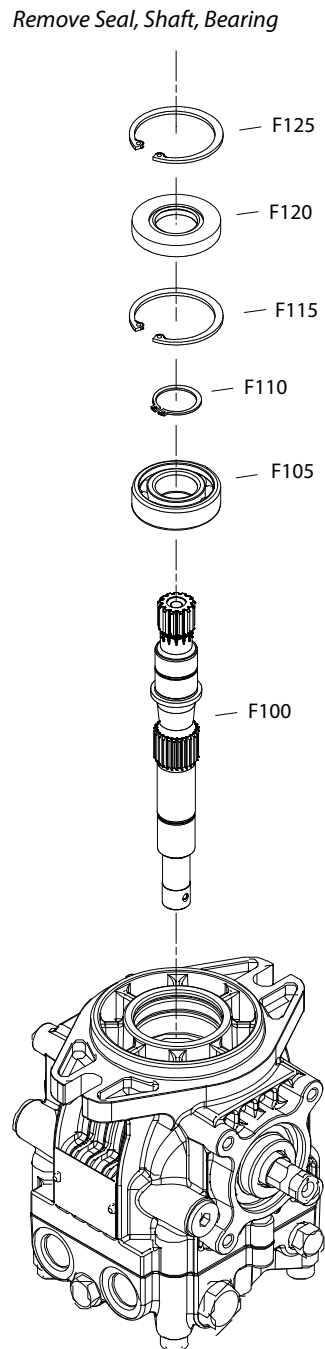

Minor repair

DDC20/24 shaft removal

1. Using a retaining ring pliers, remove retaining ring (F115).
2. Pull the shaft (F100), with bearing (F105), out of the pump. If necessary, tap lightly on the shaft to dislodge it from the internal pump components.

! **Caution**

Moving the pump with the shaft removed may dislodge the rotating group making reassembly impossible without removing the endcap.

3. If replacing the bearing (F105), remove retaining ring (F110) using a retaining ring pliers.
4. Press on the inner race to remove the bearing (F105) from the shaft.

DDC20/24 shaft inspection

1. Ensure the shaft and its splines are straight and free of damage or heavy wear.
2. Inspect the shaft surface where it meets the shaft seal.
3. Replace the shaft if a groove exists at the sealing land surface that may let dirt into or hydraulic fluid out of the unit.
4. Clean the sealing area with a nonabrasive material if necessary.
5. Lubricate the shaft with a light coat of hydraulic fluid before assembly.

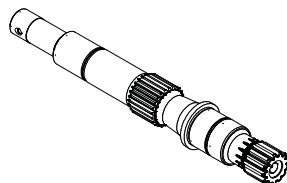

DDC20/24 shaft bearing inspection

1. Clean bearing with a solvent and lubricate with hydraulic fluid.
 Replace the bearing if issues persist after cleaning.
2. Rotate the bearing in hand. The bearing should rotate smoothly.
3. Inspect for wear, or pitting.
 If excessive wear is found, replace the bearing.

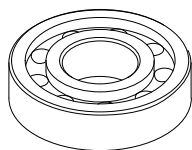

DDC20/24 shaft and seal assembly

1. Position the pump with the shaft end pointing up.
If previously removed; press bearing onto shaft by applying force to the inner race.
2. Lubricate and install bearing (F105) with hydraulic fluid.
3. Install retaining ring (F110) using retaining ring pliers.
4. Install shaft (F100) with bearing (F105) into housing. Ensure the shaft splines engage the block splines and the shaft end slides smoothly into the rear bearing. It may be necessary to tap lightly on the shaft to seat the bearing.

Minor repair

5. Using retaining ring pliers, install the retaining ring (F115).
6. Cover shaft splines with an installation sleeve or packaging tape to protect seal during installation. Lubricate new shaft seal (F120), press into housing until it bottoms out. Press evenly to avoid binding and damaging the seal.

! Caution

Do not damage the housing bore, shaft or rear bearing when installing the shaft and shaft seal. All components should fit together smoothly.

7. Using retaining ring pliers, install the seal retaining ring (F125).

Install shaft /seal/bearing

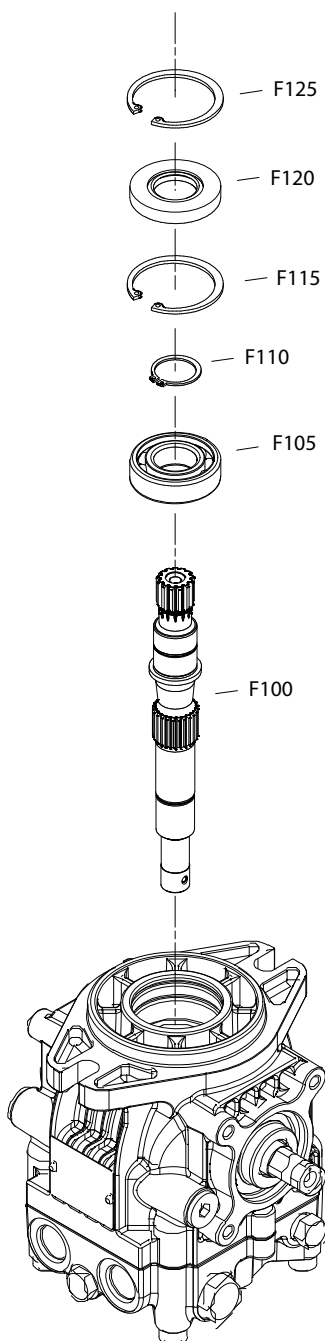

Minor repair

High pressure relief valve (HPRV)

DDC20/24 high pressure relief valve (HPRV) removal

1. Mark the location of each valve for proper reassembly.
2. Remove the HPRV valve plugs (J140/J150).
3. Remove and discard O-rings (QJ020).
4. Use a magnet to remove the valves (N110/P110) and springs (N100/P100).

HPRV removal

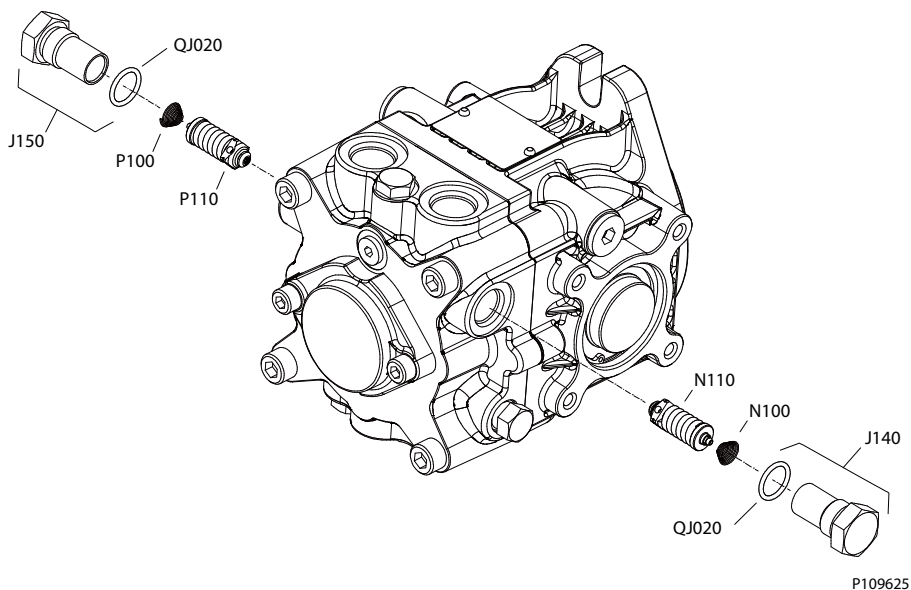

HPRV plug

Item	Wrench size	Torque
J140/J150	24 mm	78 N•m [57 lbf•ft]

DDC20/24 high pressure relief valve (HPRV) inspection

Inspect the plug and internal parts of cartridge. If parts are worn or damaged, replace the entire cartridge.

DDC20/24 high pressure relief valve (HPRV) assembly

1. Lubricate and install new O-rings (QJ020) onto each plug (J140/J150).
2. Verify that the springs (N100/P100) are properly retained on the valves (N110/P110).
3. Install the valves (N110/P110) in their original location as noted during disassembly. Ensure each valve assembly moves freely in its bore.
4. Torque plugs per table.
5. Operate vehicle/machine through full range of controls to ensure proper operation. Check for leaks.

Minor repair

Charge pressure relief valve (CPRV)

DDC20/24 charge pressure relief valve (CPRV) removal

1. Remove the charge pressure relief valve plug (J320). Remove and discard O-ring (QJ040).
2. Use a magnet to remove the spring (L200).
3. Use a magnet to remove the charge relief poppet (L100).

DDC20/24 Charge pressure relief valve (CPRV) inspection

1. Inspect charge pressure relief valve (L100) for wear or damage.
2. Inspect spring (L200).
 Replace any damaged components.

DDC20/24 charge pressure relief valve (CPRV) assembly

1. Lubricate and insert the charge relief valve poppet (L100) and spring (L200) into the endcap.
2. Lubricate and install a new O-ring (QJ040).
3. Install the charge relief valve plug (J320). Torque plug per table.

DDC20/24 Remove CPRV

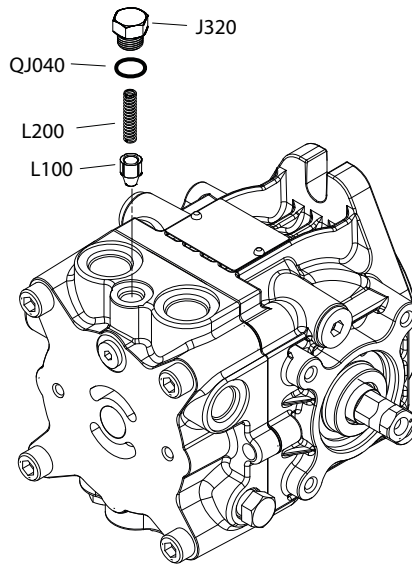

Charge pressure relief valve plug

Item	Wrench size	Torque
J320	17 mm	24 N•m [18 lbf•ft]

Minor repair

Loop flushing valve

DDC20/24 loop flushing valve removal

1. Remove the loop flushing valve plugs (J220/J230). Remove and discard O-rings (J220A/J230A).
2. Use a magnet to remove the springs (H150) and spring guides (H200).
3. Use a magnet to remove the loop flushing spool (H100).

DDC20/24 loop flushing valve inspection

1. Inspect the springs (H150). Replace the springs if they are warped or bent.
2. Inspect the loop flush spool (H100), replace it if it is worn or damaged.
3. Inspect plugs (J220/J230) and spring guides (H200) for wear.
4. Install new O-rings (J220A/J230A) to plugs (J220/J230) before assembly.

DDC20/24 loop flushing valve assembly

1. Lubricate and insert the loop flushing spool (H100) into endcap.

Ensure the spool moves freely in its bore.

2. Install the spring guides (H200) and springs (H150).
3. Lubricate and install the O-rings (J220A/J230A) on the plugs.
4. Thread the loop flushing valve plugs (J220/J230) into the endcap and torque plugs per table.

DDC20/24 Remove loop flushing valve

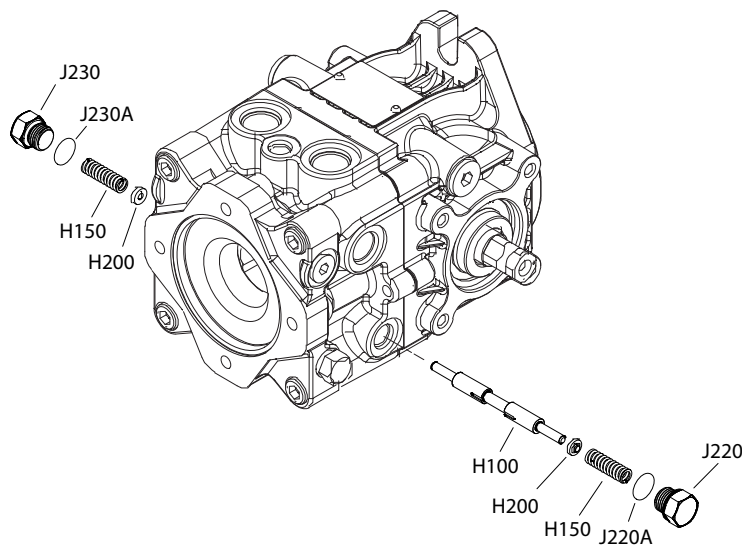

Loop flushing valve plugs

Item	Wrench size	Torque
J220/J230	11/16 inch	35 N·m [26 lbf·ft]

Minor repair

Bypass valve

DDC20/24 bypass valve removal

1. Remove the bypass valve (M100).
2. Remove and discard the O-rings (M130 and M110) and the backup ring (M120).

DDC20/24 bypass valve inspection

1. Inspect the valve. If the bypass valve (M100) is damaged, replace it.
2. Replace O-rings (M110 & M130) and back-up ring (M120) before assembly.

DDC20/24 bypass valve assembly

1. Lubricate and install new O-rings (M130 and M110) and backup ring (M120) onto cartridge.
2. Install the bypass valve (M100/M200). Torque valve per table.

DDC20/24 Remove bypass valve

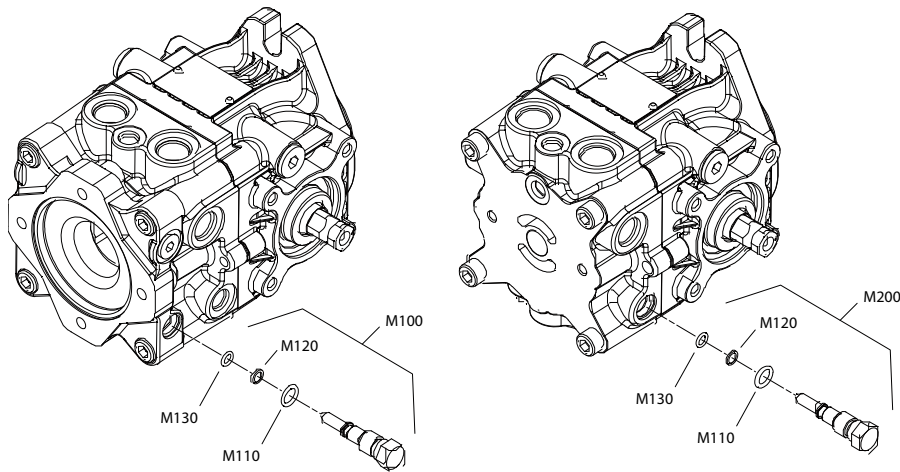

Bypass valve plug

Item	Wrench size	Torque
M100/M200	17 mm	12 N•m [9 lbf•ft]

Minor repair

Optional coupling

DDC20/24 optional coupling removal

Remove the coupling (J538).

DDC20/24 coupling inspection

Inspect the coupling. If the coupling is damaged, replace it.

DDC20/24 coupling assembly

Lubricate and install the coupling (J538).

DDC20/24 Remove coupling

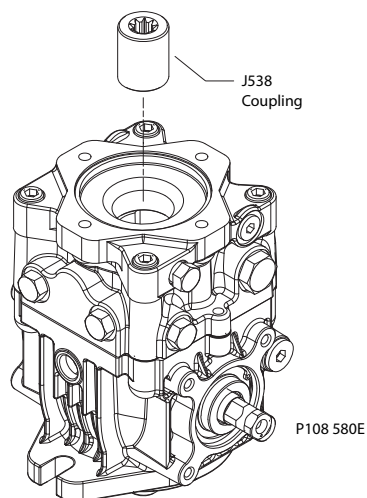

Torque charts

DDC20/24 charge pump fasteners and torque chart

Aux pad (left) and gerotor (right)

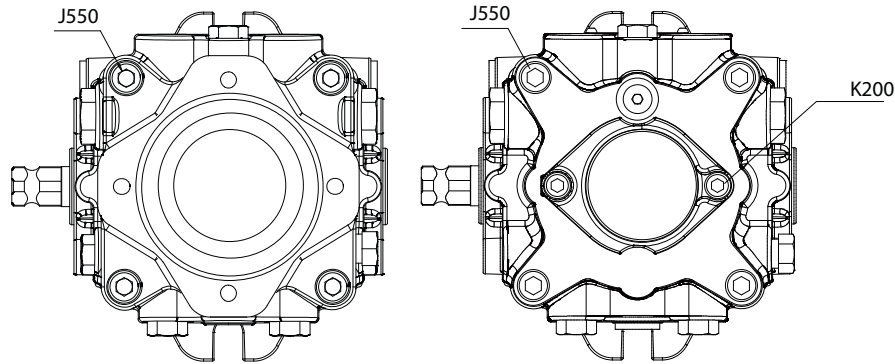

Item	Fastener	Wrench size	Torque
K200	Charge pump cover mounting bolt	6 mm internal hex	20 N·m [15 lbf·ft]
J550	Endcap/charge pump cover mounting bolts	8 mm internal hex	39 N·m [29 lbf·ft]

DDC20/24 implement pump fasteners and torque chart

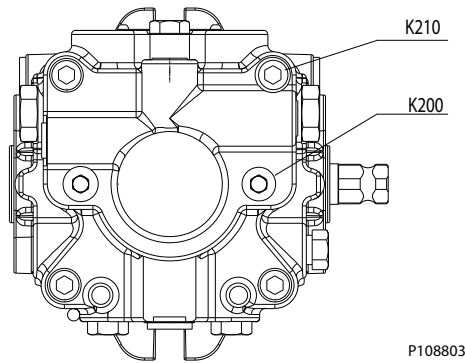

Item	Fastener	Wrench size	Torque
K200	Charge pump cover mounting bolt	8 mm internal hex	60 N·m [44 lbf·ft]
K210	Endcap/implement pump housing mounting bolt	8 mm internal hex	39 N·m [29 lbf·ft]

Torque charts

DDC20/24 Gerotor- plug sizes and torque chart

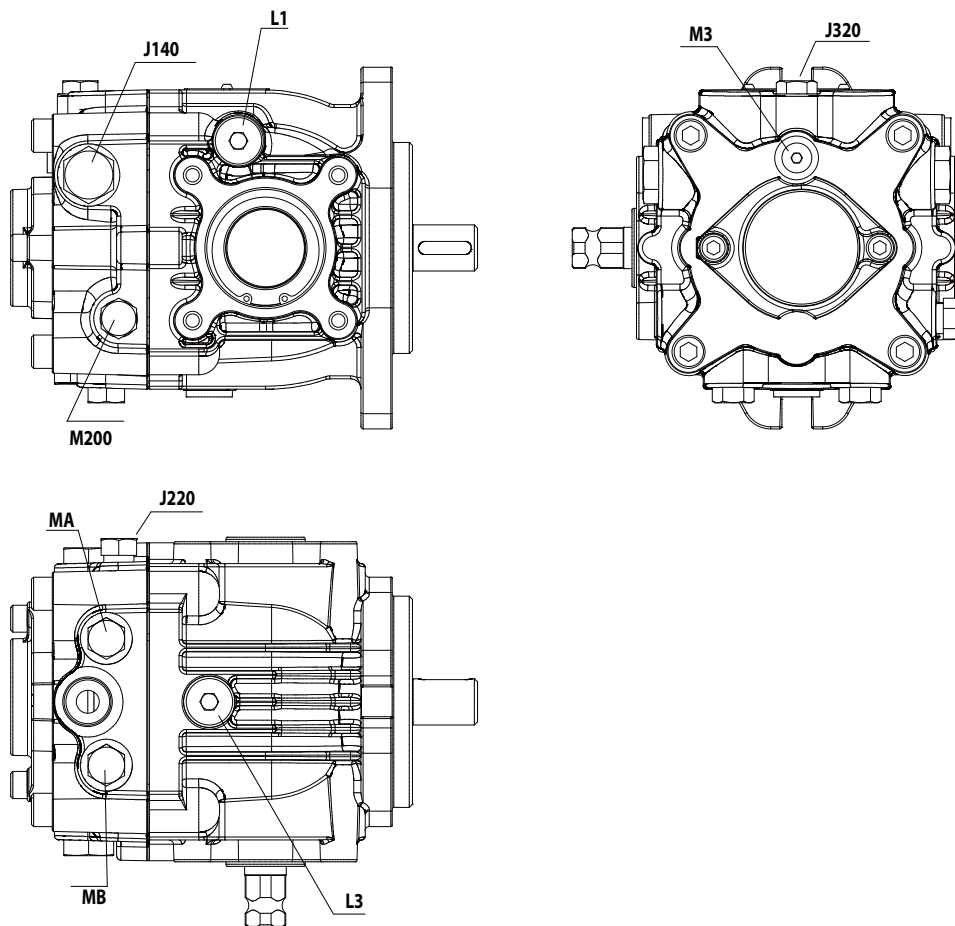

⚠ Warning

Do not over torque the case drain plugs (L1, L2, L3)

Item	Plug	Port dimensions	Wrench size	Torque
J140/J150	HPRV	3/4-16 UNF	24 mm	78 N•m [57 lbf•ft]
L1/L2/L3	Case drain	3/4-16 UNF	5/16 inch internal hex	29 N•m [21 lbf•ft]
J220/J230	Loop flushing valve plug	9/16-18 UNF	11/16 inch internal hex	35 N•m [26 lbf•ft]
M100/M200	Bypass valve	9/16-18 UNF	17 mm	12 N•m [9 lbf•ft]
J320	CPRV	1/2-20 UNF	17 mm	24 N•m [18 lbf•ft]
MA/MB	System Pressure Gauge Ports	9/16-18 UNF	11/16 inch	35 N•m [26 lbf•ft]
M3	Charge Pressure Gauge Port	7/16-20 UNF	3/16 inch internal hex	19 N•m [14 lbf•ft]

Torque charts

DDC20/24 aux pad plug sizes and torque chart

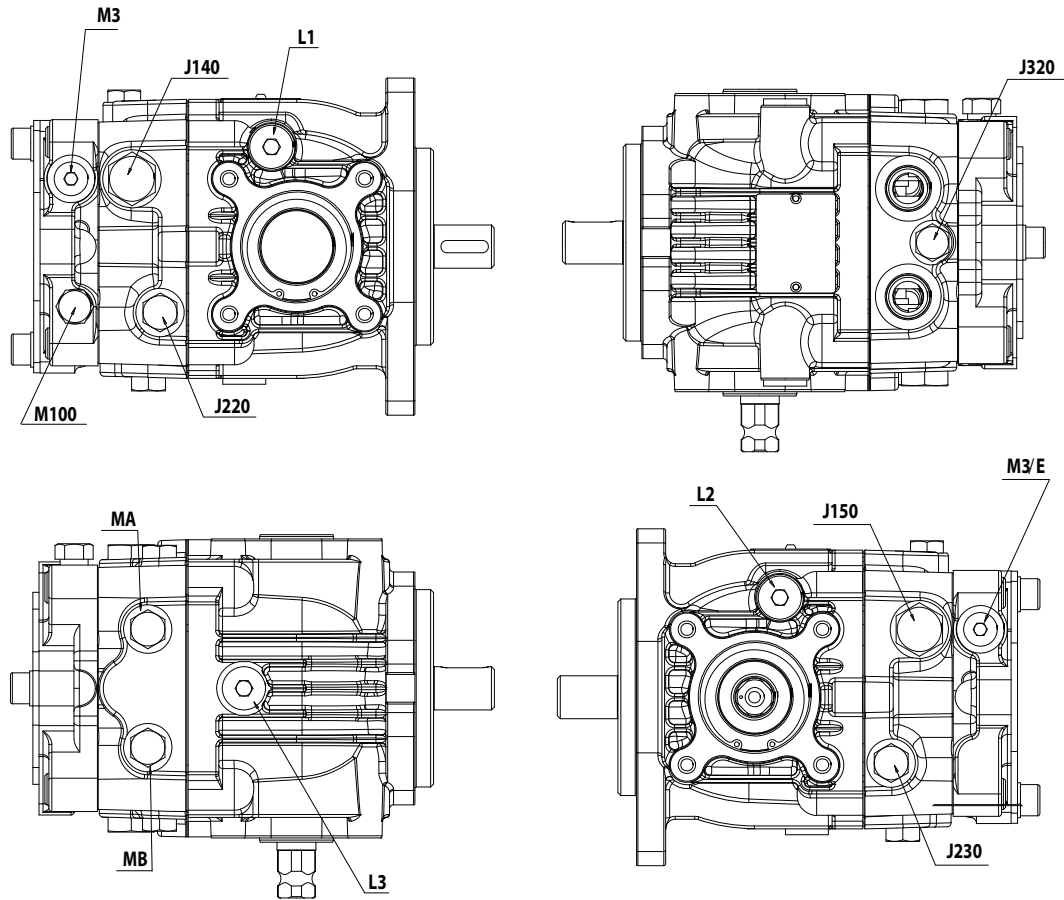

⚠ Warning

Do not over torque the case drain plugs (L1, L2, L3).

Item	Plug	Port dimensions	Wrench size	Torque
J140/J150	HPRV	3/4-16 UNF	24 mm	78 N·m [57 lbf·ft]
M3/E	Charge gauge/ Charge inlet	9/16-18 UNF	1/4 inch internal hex	35 N·m [26 lbf·ft]
L1/L2/L3	Case drain	3/4-16 UNF	5/16 inch internal hex	30 N·m [22 lbf·ft]
J220/J230	Loop flushing valve plug	9/16-18 UNF	11/16 inch internal hex	35 N·m [26 lbf·ft]
M100/M200	Bypass valve	9/16-18 UNF	17 mm	12 N·m [9 lbf·ft]
J320	CPRV	1/2-20 UNF	17 mm	24 N·m [18 lbf·ft]
MA/MB	System Pressure Gauge Ports	9/16-18 UNF	11/16 inch	35 N·m [26 lbf·ft]

Torque charts

DDC20/24 implement pump plug sizes and torque chart

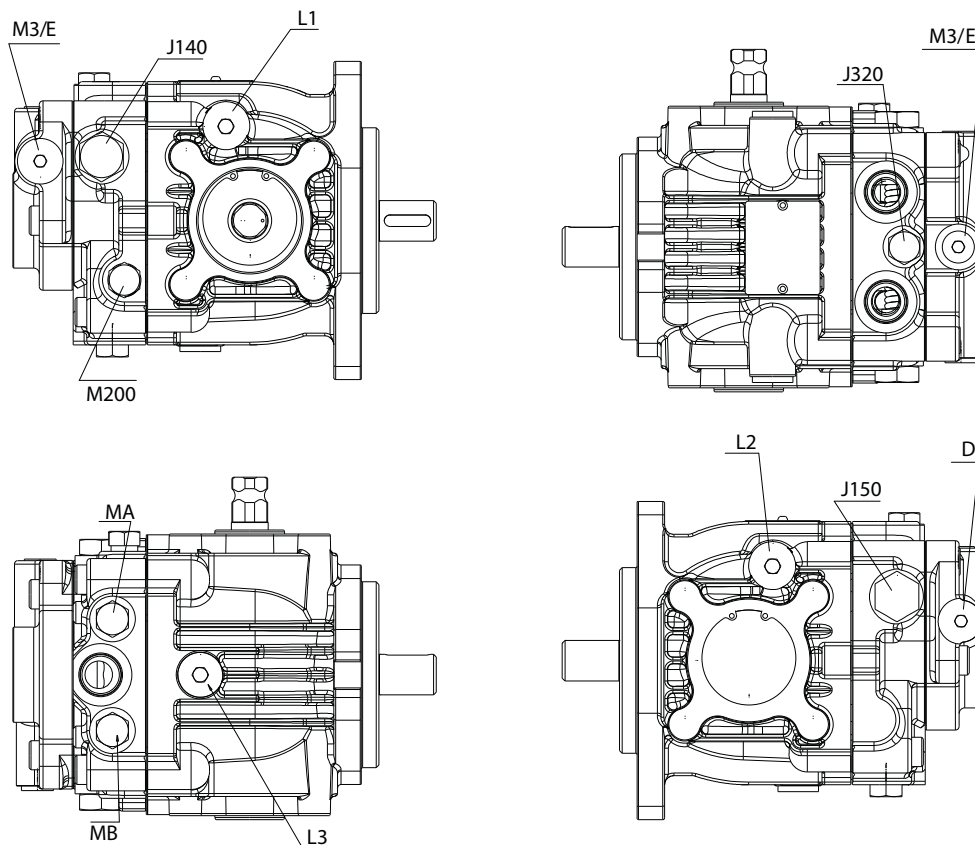

⚠ Warning

Do not over torque the case drain plugs (L1, L2, L3).

Item	Plug	Port dimensions	Wrench size	Torque
J140/J150	HPRV	3/4-16 UNF	24 mm	78 N•m [57 lbf•ft]
M3/E	Charge gauge/Implement return	9/16-18 UNF	1/4 inch internal hex	35 N•m [26 lbf•ft]
L1/L2/L3	Case drain	3/4-16 UNF	5/16 inch internal hex	29 N•m [21 lbf•ft]
M200	Bypass valve	9/16-18 UNF	17 mm	12 N•m [9 lbf•ft]
J320	CPRV	1/2-20 UNF	17 mm	24 N•m [18 lbf•ft]
MA/MB	System Pressure Gauge Ports	9/16-18 UNF	11/16 inch	35 N•m [26 lbf•ft]
D	Implement discharge	9/16-18UNF	1/4 inch internal hex	35 N•m [26 lbf•ft]

Products we offer:

- Cylinders
- Electric converters, machines, and systems
- Electronic controls, HMI, and IoT
- Hoses and fittings
- Hydraulic power units and packaged systems
- Hydraulic valves
- Industrial clutches and brakes
- Motors
- PLUS+1® software
- Pumps
- Steering
- Transmissions

Danfoss Power Solutions designs and manufactures a complete range of engineered components and systems. From hydraulics and electrification to fluid conveyance, electronic controls, and software, our solutions are engineered with an uncompromising focus on quality, reliability, and safety.

Our innovative products makes increased productivity and reduced emissions a possibility, but it's our people who turn those possibilities into reality. Leveraging our unsurpassed application know-how, we partner with customers around the world to solve their greatest machine challenges. Our aspiration is to help our customers achieve their vision — and to earn our place as their preferred and trusted partner.

Go to www.danfoss.com or scan the QR code for further product information.

**Hydro-Gear**

www.hydro-gear.com

Daikin-Sauer-Danfoss

www.daikin-sauer-danfoss.com

**Danfoss
Power Solutions (US) Company**
2800 East 13th Street
Ames, IA 50010, USA
Phone: +1 515 239 6000

**Danfoss
Power Solutions GmbH & Co. OHG**
Krokamp 35
D-24539 Neumünster, Germany
Phone: +49 4321 871 0

**Danfoss
Power Solutions ApS**
Nordborgvej 81
DK-6430 Nordborg, Denmark
Phone: +45 7488 2222

**Danfoss
Power Solutions Trading
(Shanghai) Co., Ltd.**
Building #22, No. 1000 Jin Hai Rd
Jin Qiao, Pudong New District
Shanghai, China 201206
Phone: +86 21 2080 6201

Danfoss can accept no responsibility for possible errors in catalogues, brochures and other printed material. Danfoss reserves the right to alter its products without notice. This also applies to products already on order provided that such alterations can be made without subsequent changes being necessary in specifications already agreed. All trademarks in this material are property of the respective companies. Danfoss and the Danfoss logotype are trademarks of Danfoss A/S. All rights reserved.