

ENGINEERING
TOMORROW

Danfoss

Service Manual

H1T 045/053, 060/068

Axial Piston Tandem Pumps

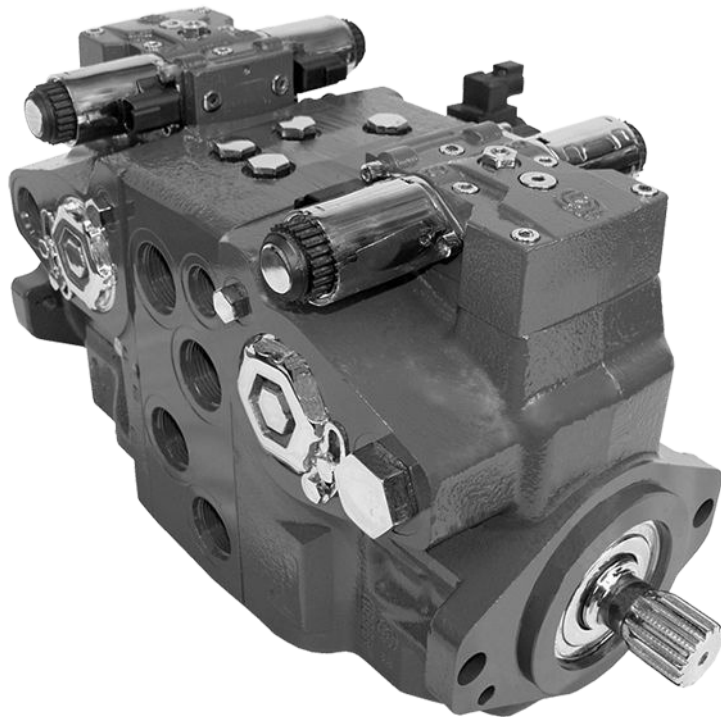

Revision history*Table of revisions*

Date	Changed	Rev
January 2025	Corrected D050 control assembly torque	0502
December 2021	Added HDC control	0501
September 2020	Changed document number from 'AX00000103' to 'AX152886481761' and added important info about PL screens	0405
November 2018	Major layout update.	0401
June 2018	Angle sensor topics added.	0303
August 2017	Minor update.	0302
May 2017	Added frames H1T 060/068	0301
Oct. 2007-March 2015	Various changes.	AB-BD
Jun 2007	First edition.	AA

Contents

Introduction

Hydrostatics Servicing Overview.....	5
General Servicing Instructions.....	5
Safety Precautions.....	6
Independent Braking System.....	6
High Inlet Vacuum.....	6
Manufacturer's Warranty.....	6
The Basic Closed Circuit.....	7
Case Drain and Heat Exchanger.....	7
Tandem Pumps Design.....	8
H1T pumps pictorial diagram.....	9
H1T Tandem Pumps Schematics.....	10
System Schematic for Tandem Pumps.....	11

Operation

Pressure Limiter Valves.....	12
Pressure Limiter Sectional View.....	12
High Pressure Relief Valve (HPRV) and Charge Check Valve.....	13
HPRV/Charge Check Valve Sectional View.....	13
Charge Pressure Relief Valve (CPRV).....	15
Electrical Displacement Control (EDC).....	15
EDC Operation.....	16
Hydraulic Displacement Control (HDC).....	17
HDC principle.....	17
HDC operation.....	17
Manual Override (MOR).....	19
Manual Displacement Control (MDC)	19
MDC operation.....	20
MDC Torque.....	21
Neutral start switch (NSS).....	21
Case Gauge Port M14.....	21
Control-Cut-Off (CCO) and Brake Release Valves.....	21

Operating Parameters

Input Speed.....	24
Independent Braking System.....	24
System Pressure.....	24
Servo Pressure.....	26
Charge Pressure.....	26
Charge Pump Inlet Pressure.....	26
Case Pressure.....	26
External Shaft Seal Pressure.....	27
Temperature.....	27
Viscosity.....	27

Technical Specifications

H1 Pumps General Specification.....	28
Technical Data for H1 Tandem Pumps.....	28
Operating parameters for H1 Tandem Pumps.....	29
Fluid Specification.....	30

Fluid and Filter Maintenance Recommendations

Pressure Measurements

Port locations and gauge installation - 045/053.....	32
Port locations and gauge installation - 060/068.....	33

Initial Startup Procedures

Start-Up Procedure.....	34
-------------------------	----

Troubleshooting

Safety Precautions.....	36
-------------------------	----

Contents

High Inlet Vacuum.....	36
Unintended machine movement.....	36
Independent Braking System.....	36
Manufacturer's Warranty.....	36
Electrical Troubleshooting.....	37
Integral Filter Bypass.....	37
Neutral Difficult or Impossible to Find.....	37
Transmission Operates Normally in One Direction Only.....	37
System Operating Hot.....	38
System Will Not Operate in Either Direction.....	38
System Noise or Vibration.....	39
Sluggish System Response.....	39

Adjustments

Standard Procedures.....	40
Charge Pressure Relief Valve Adjustment.....	41
Pressure Limiter.....	44
Pressure Limiter Screens.....	44
Pressure Limiter Adjustment (060/068 only).....	44
Charge check / HPRV adjustment.....	47
Engaging the Bypass Function.....	48
Displacement Limiter Adjustment for Tandem Pumps.....	49
Control Neutral Adjustment.....	51
Mechanical Neutral Adjustment.....	53
Pump setup.....	53
Servo Adjustment for Tandem Pumps.....	54

Minor repair

Standard Procedures at Removing Pump.....	57
EDC/HDC Control Repair.....	57
EDC/HDC Control Installation.....	58
Control Solenoids Repair.....	59
MDC Control Repair.....	60
MDC Control Assembly.....	61
Angle sensor on EDC Repair.....	62
EDC with Angle Sensor Repair.....	63
Shaft, Seal and Bearing Repair.....	65
Shaft, Seal and Bearing Installation.....	66
Charge Pump Repair (045/053 only).....	67
Charge Pump Installation.....	68
Charge Check and HPRV Repair (045/053).....	69
HPRV Port Relationship.....	70
HPRV (60/68).....	71
Pressure Limiter Screens.....	71
HPRV Repair (060/068).....	71
Charge Pressure Relief Valve Repair.....	73
Control Cut-off Valve / Brake Valve Repair.....	74

Torque Chart

Fasteners and Plugs.....	76
Fastener Size and Torque Chart.....	77
Plug Size and Torque Chart.....	78

Introduction

Hydrostatics Servicing Overview

This manual includes information on installation, maintenance, and minor repair of the . It includes a description of the unit and its individual components, troubleshooting information, and minor repair procedures.

Performing minor repairs may require the unit to be removed from the vehicle/machine. Thoroughly clean the unit before beginning maintenance or repair activities. Since dirt and contamination are the greatest enemies of any type of hydraulic equipment, follow cleanliness requirements strictly. This is especially important when changing the system filter and when removing hoses or plumbing.

A worldwide network of Danfoss Global Service Partners is available for major repairs. Danfoss trains and certifies Global Service Partners on a regular basis. You can locate your nearest Global Service Partner using the distributor locator at <http://www.danfoss.com>.

For detailed technical information about the , please see the relevant technical information document.



Attention

Major repairs requiring the removal of a unit's center section, servo sleeves, or front flange voids the warranty unless a Danfoss Authorized Service Center performs them.

General Servicing Instructions

Follow these general procedures when repairing this product:

Icon	Description	Instructions
	Remove the unit	<ul style="list-style-type: none"> • If necessary, remove the unit from the vehicle/machine. • Chock the wheels on the vehicle or lock the mechanism to inhibit movement. • Be aware that hydraulic fluid may be under high pressure and/or hot. • Inspect the outside of the pump and fittings for damage. • Cap hoses after removal to prevent contamination.
	Keep it clean	<ul style="list-style-type: none"> • Cleanliness is a primary means of assuring satisfactory pump life, on either new or repaired units. • Clean the outside of the pump thoroughly before disassembly. • Take care to avoid contamination of the system ports. • Cleaning parts by using a clean solvent wash and air drying is usually adequate. • As with any precision equipment, keep all parts free of foreign materials and chemicals. • Protect all exposed sealing surfaces and open cavities from damage and foreign material. • If left unattended, cover the pump with a protective layer of plastic.
	Replace O-ring, gasket	<ul style="list-style-type: none"> • Danfoss recommends that you replace all O-rings, seals and gaskets. • Lightly lubricate all O-rings with clean petroleum jelly prior to assembly.
	Secure the unit	<ul style="list-style-type: none"> • For repair, place the unit in a stable position with the shaft pointing downward. • It will be necessary to secure the pump while removing and torquing end covers, controls, and valves.

Introduction

Safety Precautions

Always consider safety precautions before beginning a service procedure. Protect yourself and others from injury. Take the following general precautions whenever servicing a hydraulic system.

Unintended machine movement

Unintended movement of the machine or mechanism may cause injury to the technician or bystanders. Secure the machine or disable/disconnect the mechanism while servicing to protect against unintended movement.

Independent Braking System

Unintended vehicle or machine movement hazard. Exceeding maximum speed may cause a loss of hydrostatic drive line power and braking capacity.

Machine manufacturer is responsible to provide a braking system, redundant to the hydrostatic transmission, sufficient to stop and hold the vehicle or machine in the event of hydrostatic drive power loss. The braking system must also be sufficient to hold the machine in place when full power is applied.

High Inlet Vacuum

High inlet vacuum causes cavitation which can damage internal pump components.

Manufacturer's Warranty

Contamination can damage internal components and void the manufacturer's warranty.

Take precautions to ensure system cleanliness when removing and installing system lines.

Fluid Under Pressure

Escaping hydraulic fluid under pressure can have sufficient force to penetrate your skin causing serious injury and/or infection. This fluid may also be hot enough to cause burns.

Relieve pressure in the system before removing hoses, fittings, gauges, or components. Never use your hand or any other body part to check for leaks in a pressurized line. Use caution when dealing with hydraulic fluid under pressure. Seek medical attention immediately if you are cut by hydraulic fluid.

Flammable cleaning solvents

Some cleaning solvents are flammable.

Do not use cleaning solvents in an area where a source of ignition may be present to avoid possible fire.

Personal safety

Protect yourself from injury whenever servicing a hydraulic system.

Use proper safety equipment, including safety glasses, at all times.

Hazardous material

Hydraulic fluid contains hazardous material.

Avoid prolonged contact with hydraulic fluid. Always dispose of used hydraulic fluid according to state, and federal environmental regulations.

Introduction

The Basic Closed Circuit

Hydraulic lines connect the main ports of the pump to the main ports of the motor. Fluid flows in either direction from the pump to the motor and back. Either of the hydraulic lines can be under high pressure. In pumping mode the position of the pump swashplate determines which line is high pressure as well as the direction of fluid flow.

Case Drain and Heat Exchanger

The pump and motor require case drain lines to remove hot fluid from the system. The pump and motor drain from the topmost port to ensure the cases remain full of fluid.

The motor case drain can connect to the lower drain port on the pump housing or it can tee into the case drain line upstream of the heat exchanger. A heat exchanger with bypass valve cools the case drain fluid before it returns to the reservoir.

Introduction

Tandem Pumps Design

Danfoss H1 tandem closed circuit piston pumps convert input torque to hydraulic power. The tandem design powers two independent drive trains for dual-path propel applications.

The two-piece input shaft transmits rotational force to the cylinder block. A splined coupling connects the front and rear shafts. Bearings at the front, rear, and center of the pump support the shaft. Splines connect each shaft to a cylinder block. A lip-seal at the front end of the pump prevents leakage where the shaft exits the pump housing. The spinning cylinder block contains nine reciprocating pistons. Each piston has a brass slipper connected at one end by a ball joint. The block spring, ball guide, and slipper retainer hold the slippers to the swashplate. The reciprocating movement of the pistons occurs as the slippers slide against the inclined swashplates during rotation.

Via the valve plates, one half of each cylinder block is connected to port A or C and the other half to port B or D. Front and rear sections have independent porting in the center section. As each piston cycles in and out of its bore, fluid is drawn from one port and displaced to the other thereby imparting hydraulic power into the system. A small amount of fluid is allowed to flow from the cylinder block/valve plate and slipper/swashplate interfaces for lubrication and cooling. Case drain ports return this fluid to the reservoir. An external charge pump (not shown) provides clean, cool fluid to makeup this lubricating flow and to maintain minimum loop pressure.

The angle of each swashplate controls the volume and direction of fluid displaced into the system. The servo pistons control the angle of the swashplates. Each pump control, by varying the pressure at the servo pistons, controls each piston's position. An electric signal to the control coils transmits the command from the operator to the pump. Mechanical feedback of the swashplate position to the control through the feedback pins allows for very precise displacement control and increases overall system stability. Non-feedback control options do not use the mechanical feedback link.

Cross section view

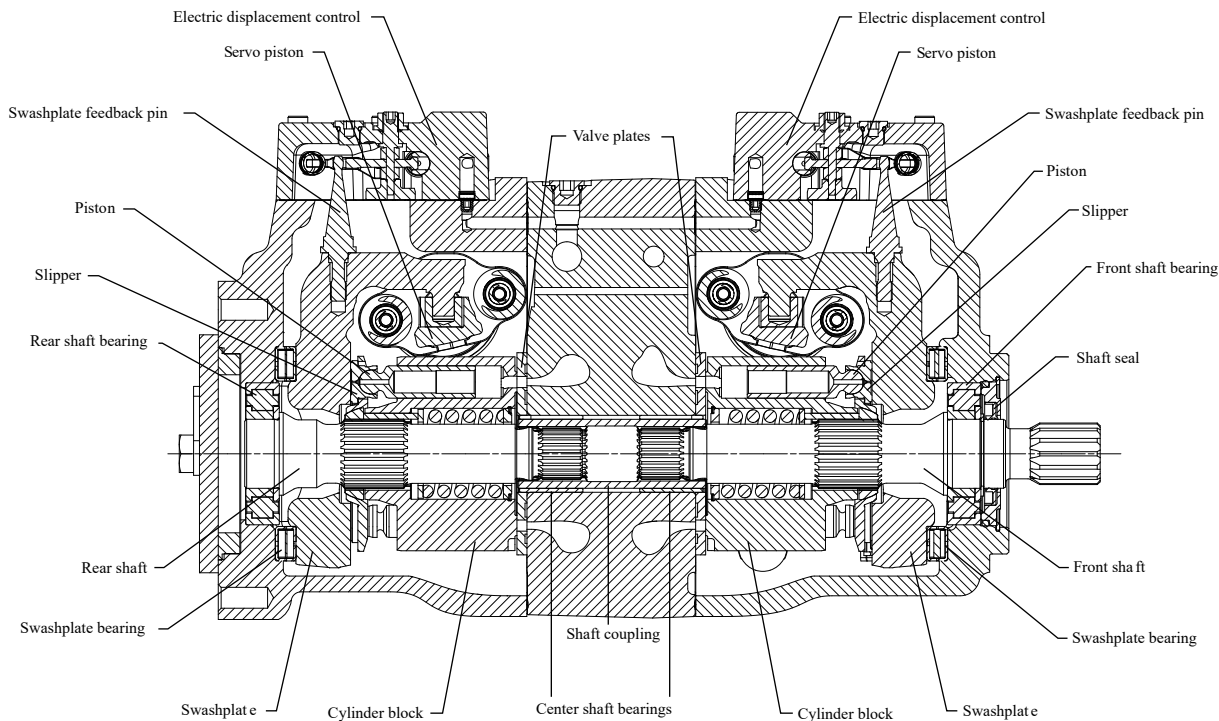

P106 146E

Introduction

H1T pumps pictorial diagram

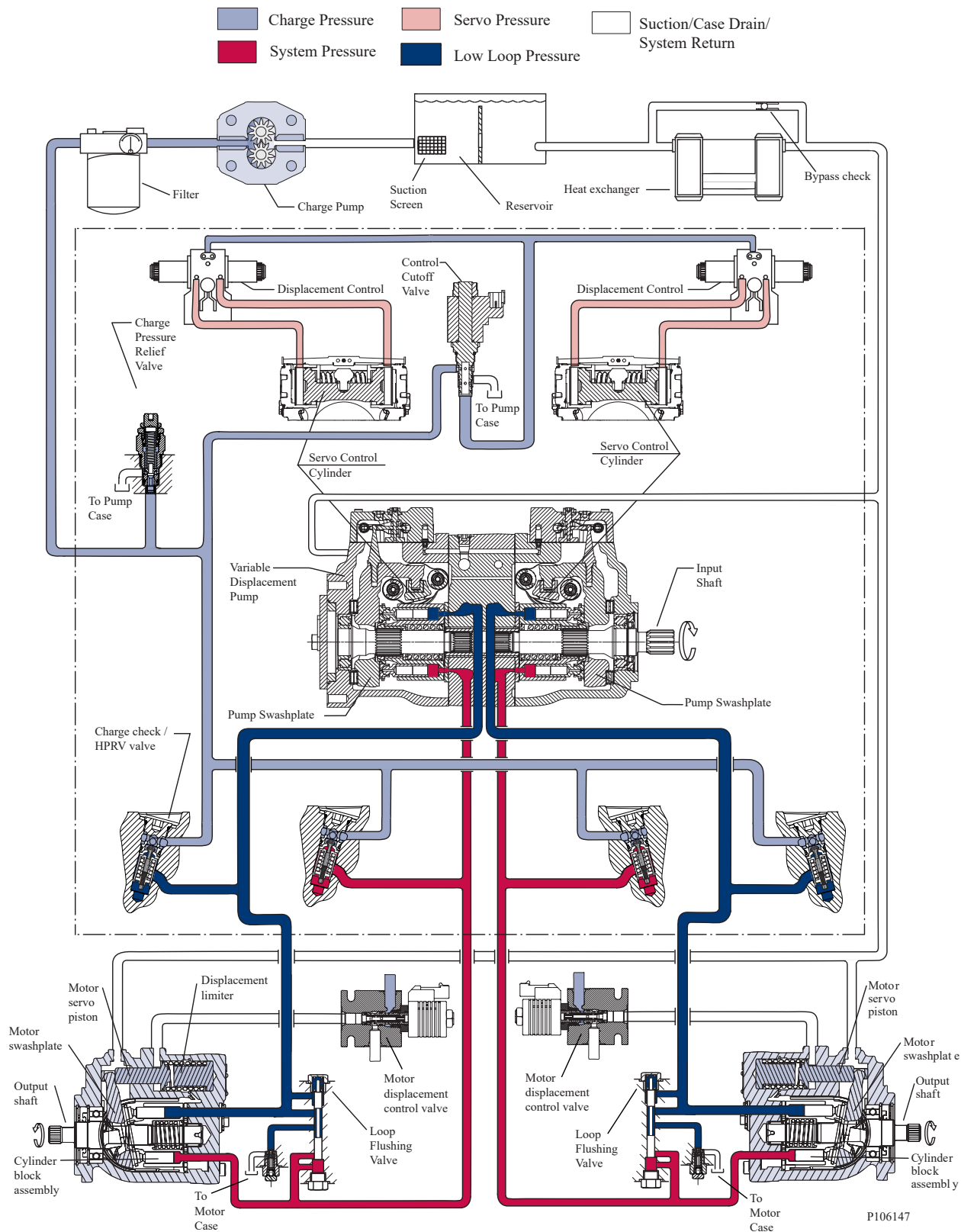

P106147

Introduction

H1T Tandem Pumps Schematics

The schematics below show the function of an H1 tandem axial piston variable displacement pump with electric displacement control (EDC) and optional control cut-off valve.

045/053 Tandem

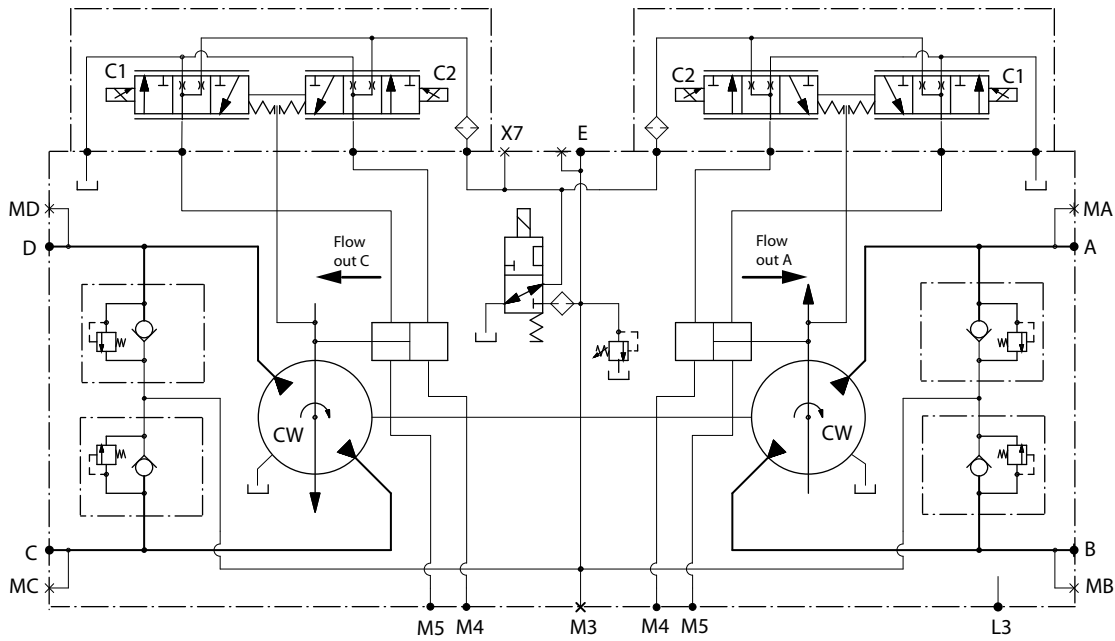

P106 148E

060/068 Tandem

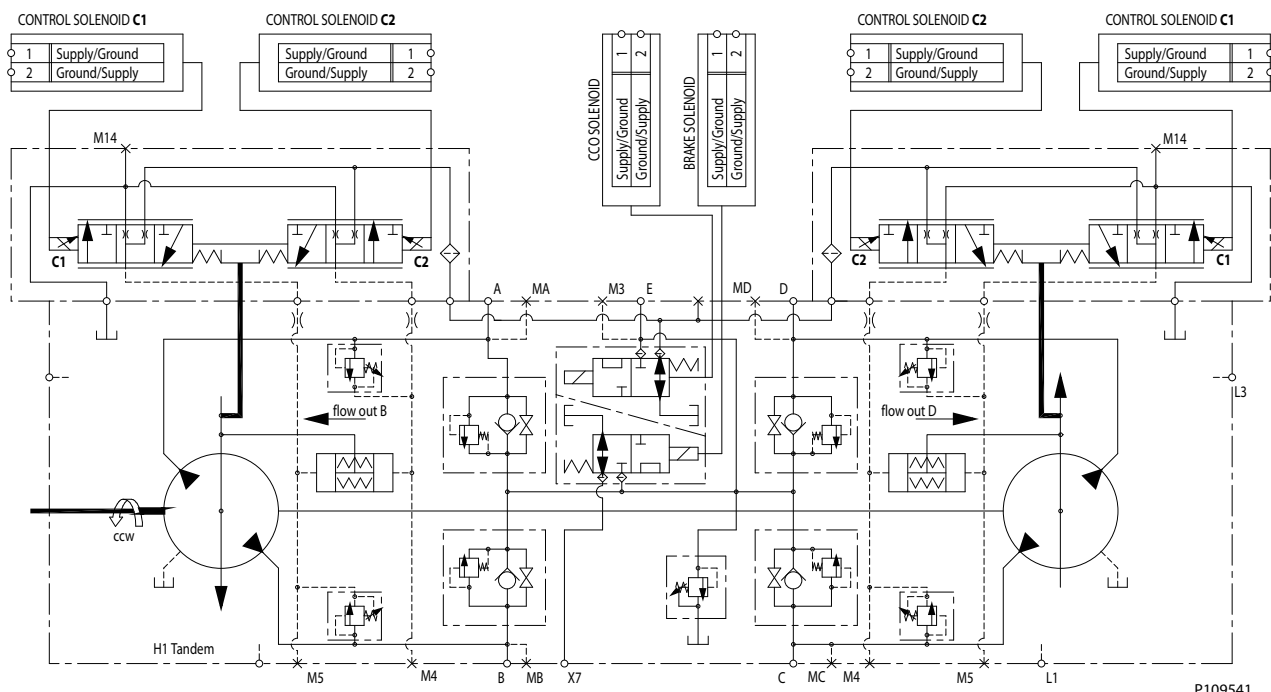

P109541

Introduction

System Schematic for Tandem Pumps

The schematic below shows the function of H1T axial piston variable displacement tandem pumps with electric displacement control (EDC).

System schematic, tandem pumps

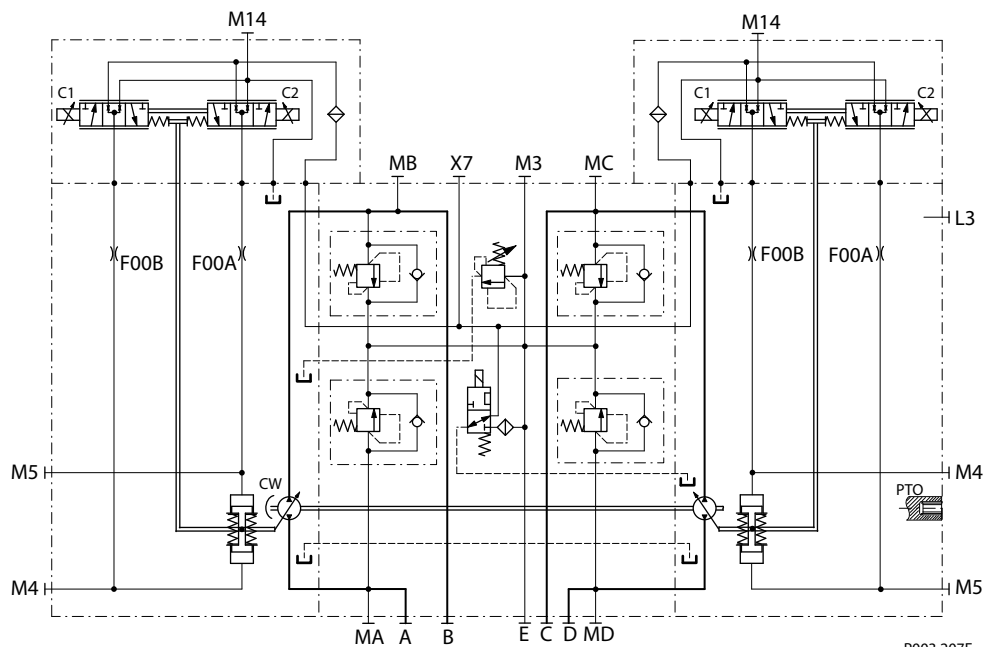

Operation

Pressure Limiter Valves

Pressure limiter valves provide system pressure protection by compensating the pump swash plate position when the set pressure of the valve is reached. A pressure limiter is a non-dissipative (non heat generating) pressure regulating system.

Each side of the transmission loop has a dedicated pressure limiter valve that is set independently. A pump configured with pressure limiter must have pressure limiters on both sides of the system pressure loop. The pump order code allows for different pressure settings to be used at each system port.

The pressure limiter setting is the maximum differential pressure between the high and low loops. When the pressure limiter setting is reached, the valve ports oil to the low-pressure side of the servo piston. The change in servo differential pressure rapidly reduces pump displacement. Fluid flow from the valve continues until the resulting drop in pump displacement causes system pressure to fall below the pressure limiter setting.

An active pressure limiter destrokes a pump to near neutral when the load is in a stalled condition. The pump swash-plate moves in either direction necessary to regulate the system pressure, including into stroke (overrunning) or over-center (winch payout).

[The pressure limiter is optional on H1 pumps \(except H1T 045/053 tandem pumps\).](#)

Pressure Limiter Sectional View

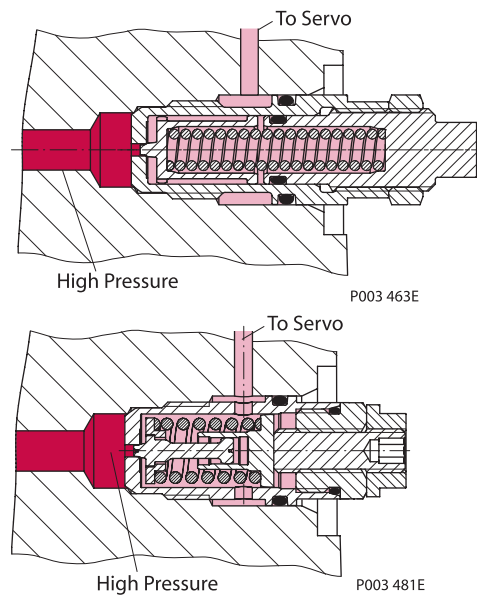

Operation

High Pressure Relief Valve (HPRV) and Charge Check Valve

All H1 pumps have a combination high pressure relief and charge check valve. The high pressure relief function is a dissipative (heat generating) pressure control valve for the purpose of limiting excessive system pressures. The charge check function replenishes the low pressure side of the working loop with charge oil.

Each side of the transmission loop has a dedicated HPRV valve that is non-adjustable with a factory set pressure. When system pressure exceeds the factory setting of the valve, oil is passed from the high pressure system loop, into the charge gallery, and into the low pressure system loop via the charge check.

The pump may have different pressure settings to be used at each system port. When an HPRV valve is used in conjunction with a pressure limiter, the HPRV valve is always factory set above the setting of the pressure limiter. The system pressure shown in the order code for pumps with only HPRV is the HPRV setting.

The system pressure shown in the order code for pumps with pressure limiter and HPRV is a reflection of the pressure limiter setting:

HPRVs are set at low flow condition. Any application or operating condition which leads to elevated HPRV flow will cause a pressure rise with flow above the valve setting. Consult factory for application review.

Excessive operation of the HPRV will generate heat in the closed loop and may cause damage to the internal components of the pump.

HPRV/Charge Check Valve Sectional View

HPRV and Charge Check Valve with Bypass Function (except 045/053)

Relief mode

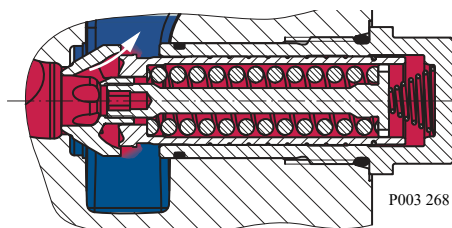

Charging mode

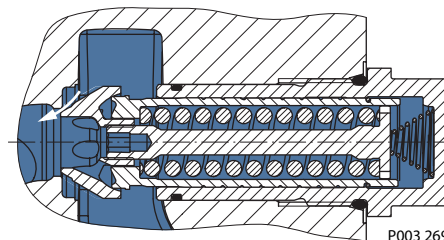

HPRV and Charge Check Valve with Bypass Function (except H1P 045/053)

Charging mode

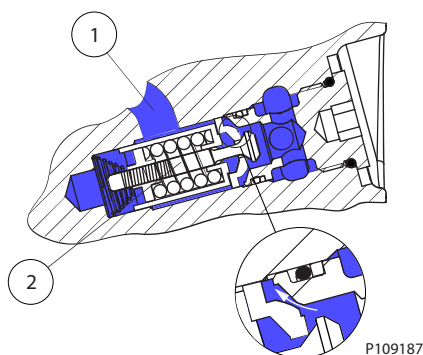

Relief mode

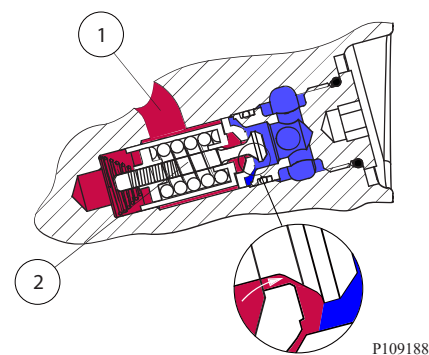

Operation

1. Low pressure side of working loop
2. Charge check and HPRV

1. High pressure side of working loop
2. Charge check and HPRV

Operation

Charge Pressure Relief Valve (CPRV)

The charge pressure relief valve is a direct acting poppet valve that opens and discharges fluid to the pump case when pressure exceeds a designated level. The charge pressure relief valve maintains charge pressure at a designated level above case pressure.

This level is nominally set with the pump running at 1800 min^{-1} (rpm), and with a fluid viscosity of $32 \text{ mm}^2/\text{s}$ [150 SUS]. In forward or reverse, charge pressure will be slightly lower than in neutral position. The model code of the pump specifies the charge pressure relief valve setting. Typical charge pressure increase from 1.2-1.5 bar per 10 l/min [17.4-21.8 psi per 2.64 US gal/min]. For external charge flow the CPRV is set according to the table below:

Standard level setting is $\Delta p = 21 \pm 1.1 \text{ bar}$ [$304 \pm 16 \text{ psi}$] with the pump running at 1500 min^{-1} (rpm) and flow = 23.80 - 29.5 l/min [6.3 - 7.8 US gal/min]. Typical charge pressure increase is 2 bar per 10 l/min [29 psi per 2.64 US gal/min].

CPRV flow setting for external charge supply

Tandem 045/053	Single 045/053	Single 060—180	Single 210/250/280
30 l/min [7.9 US gal/min]	15 l/min [3.9 US gal/min]	22.7 l/min [6.0 US gal/min]	40.0 l/min [10.6 US gal/min]

Charge pressure relief valve

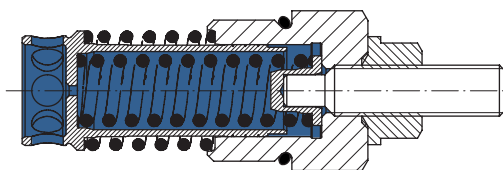

Electrical Displacement Control (EDC)

An EDC is a displacement (flow) control. Pump swash plate position is proportional to the input command and therefore vehicle or load speed (excluding influence of efficiency), is dependent only on the prime mover speed or motor displacement.

The Electrical Displacement Control (**EDC**) consists of a pair of proportional solenoids on each side of a three-position, four-way porting spool. The proportional solenoid applies a force input to the spool, which ports hydraulic pressure to either side of a double acting servo piston. Differential pressure across the servo piston rotates the swash plate, changing the pump's displacement from full displacement in one direction to full displacement in the opposite direction.

A serviceable $170 \mu\text{m}$ screen is located in the supply line immediately before the control porting spool.

Under some circumstances, such as contamination, the control spool could stick and cause the pump to stay at some displacement.

Operation

Electrical Displacement Control

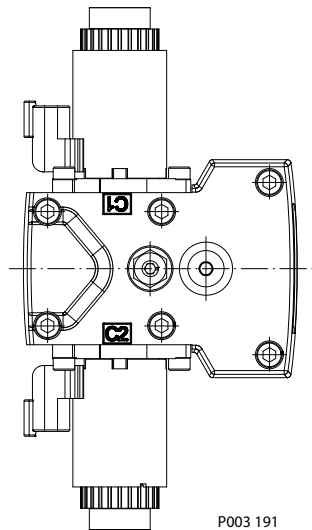

EDC schematic, feedback from swash plate

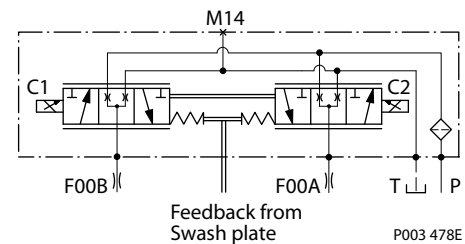

EDC Operation

H1 EDC's are current driven controls requiring a Pulse Width Modulated (PWM) signal. Pulse width modulation allows more precise control of current to the solenoids.

The PWM signal causes the solenoid pin to push against the porting spool, which pressurizes one end of the servo piston, while draining the other. Pressure differential across the servo piston moves the swashplate.

A swashplate feedback link, opposing control links, and a linear spring provide swashplate position force feedback to the solenoid. The control system reaches equilibrium when the position of the swashplate spring feedback force exactly balances the input command solenoid force from the operator. As hydraulic pressures in the operating loop change with load, the control assembly and servo/swashplate system work constantly to maintain the commanded position of the swashplate.

The EDC incorporates a positive neutral deadband as a result of the control spool porting, preloads from the servo piston assembly, and the linear control spring. Once the neutral threshold current is reached, the swashplate is positioned directly proportional to the control current. To minimize the effect of the control neutral deadband, we recommend the transmission controller or operator input device incorporate a jump up current to offset a portion of the neutral deadband.

The neutral position of the control spool does provide a positive preload pressure to each end of the servo piston assembly.

When the control input signal is either lost or removed, or if there is a loss of charge pressure, the spring-loaded servo piston will automatically return the pump to the neutral position.

Operation

Hydraulic Displacement Control (HDC)

HDC principle

An HDC is a Hydraulic Displacement Control. Pump swashplate position is proportional to the input command and therefore vehicle speed or load speed (excluding influence of efficiency), is dependent only on the prime mover speed or motor displacement.

The HDC control uses a hydraulic input signal to operate a porting spool, which ports hydraulic pressure to either side of a double acting servo piston. The hydraulic signal applies a force input to the spool which ports hydraulic pressure to either side of a double acting servo piston. Differential pressure across the servo piston rotates the swashplate, changing the pump's displacement from full displacement in one direction to full displacement in the opposite direction. Under some circumstances, such as contamination, the porting spool could stick and cause the pump to stay at some displacement.

A serviceable 175 µm screen is located in the supply line immediately before the control porting spool.

HDC control

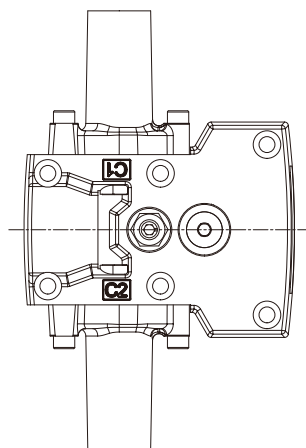

P400520

HDC schematic

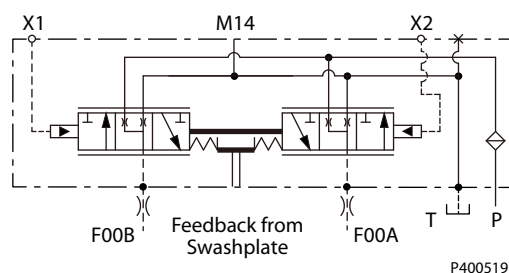

P400519

HDC operation

HDC's are hydraulically driven control which ports hydraulic pressure to either side of a porting spool, which pressurizes one end of the servo piston, while draining the other end to case. Pressure differential across the servo piston moves the swashplate.

A swashplate feedback link, opposing control linkage, and a linear spring provide swashplate position force feedback to the hydraulic pressure. As hydraulic pressures in the operating loop change with load, the control assembly and servo/swashplate system work constantly to maintain the commanded position of the swashplate.

Operation

The HDC incorporates a positive neutral dead band as a result of the control spool porting, preloads from the servo piston assembly, and the linear control spring. Once the neutral threshold point is reached, the swashplate is positioned directly proportional to the control pressure.

When the control input is either lost or removed, or if there is a loss of charge pressure, the spring loaded servo piston will automatically return the pump to the neutral position.

Pump displacement vs signal pressure

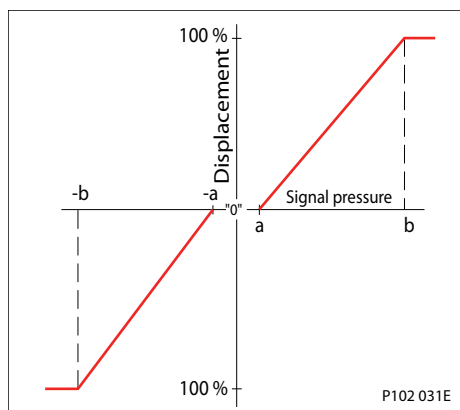

Operation

Manual Override (MOR)

All controls are available with a manual override functionality, either as a standard or as an option for temporary actuation of the control to aid in diagnostics.

Control with manual override

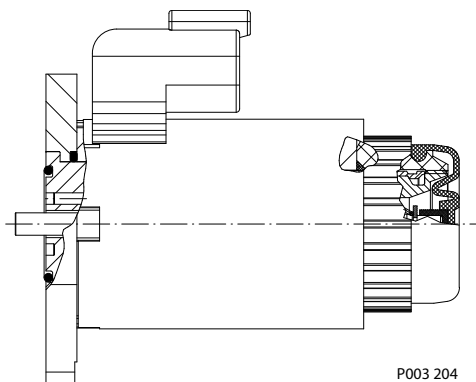

MOR schematic (EDC control shown)

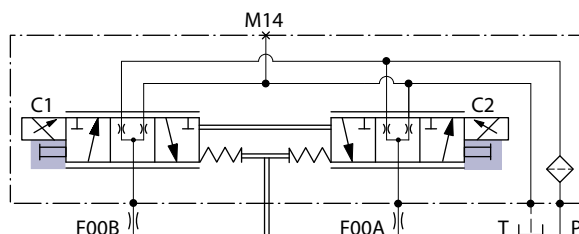

Feedback from swash plate.

The MOR plunger has a 4 mm diameter and must be manually depressed to be engaged. Depressing the plunger mechanically moves the control spool which allows the pump to go on stroke. The MOR should be engaged anticipating a full stroke response from the pump.

An o-ring seal is used to seal the MOR plunger where initial actuation of the function will require a force of 45 N to engage the plunger. Additional actuation typically require less force to engage the MOR plunger.

Proportional control of the pump using the MOR should not be expected.

Warning

Unintended MOR operation will cause the pump to go into stroke; *example: vehicle lifted off the ground.* The vehicle or device must always be in a safe condition when using the MOR function.

Refer to the pump output flow direction vs. control signal table for the relationship of solenoid to direction of flow.

Manual Displacement Control (MDC)

A Manual proportional Displacement Control (**MDC**) consists of a handle on top of a rotary input shaft. The shaft provides an eccentric connection to a feedback link. This link is connected on its one end with a porting spool. On its other end the link is connected the pumps swashplate.

This design provides a travel feedback without spring. When turning the shaft the spool moves thus providing hydraulic pressure to either side of a double acting servo piston of the pump.

Differential pressure across the servo piston rotates the swash plate, changing the pump's displacement. Simultaneously the swashplate movement is fed back to the control spool providing proportionality between shaft rotation on the control and swash-plate rotation. The MDC changes the pump displacement between no flow and full flow into opposite directions.

Operation

Under some circumstances, such as contamination, the control spool could stick and cause the pump to stay at some displacement.

For the MDC with CCO option the brake port (X7) provides charge pressure when the coil is energized to activate static function such as a brake release. The X7 port must not be used for any continuous oil consumption.

The MDC is sealed by means of a static O-ring between the actuation system and the control block. Its shaft is sealed by means of a special O-ring which is applied for low friction. The special O-ring is protected from dust, water and aggressive liquids or gases by means of a special lip seal.

Manual Displacement Control

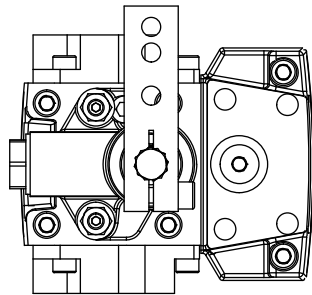

Pump displacement vs. control lever rotation

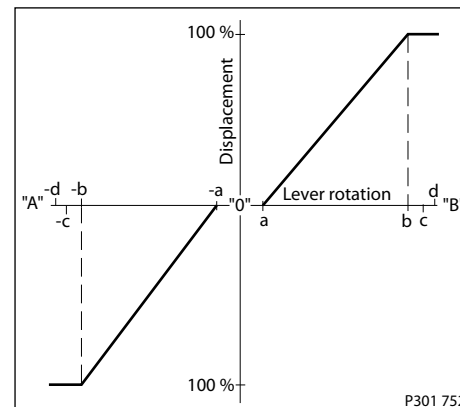

Deadband on **B** side: $a = 3^\circ \pm 1^\circ$
 Maximum pump stroke: $b = 30^\circ + 2/-1^\circ$
 Required customer end stop: $c = 36^\circ \pm 3^\circ$
 Internal end stop: $d = 40^\circ$

MDC operation

The MDC provides a mechanical dead-band required to overcome the tolerances in the mechanical actuation. The MDC contains an internal end stop to prevent turning the handle into any inappropriate position.

The MDC provides a permanent restoring moment appropriate for turning the MDC input shaft back to neutral position only. This is required to take the backlash out of the mechanical connections between the Bowden cable and the control.

High case pressure may cause excessive wear and the NSS to indicate that the control is not in neutral position. In addition, if the case pressure exceeds 5 bar there is a risk of an insufficient restoring moment. The MDC is designed for a maximum case pressure of 5 bar and a rated case pressure of 3 bar.

- Customers must install some support to limit the setting range of their Bowden cable to avoid an overload of the MDC.
- Customers can apply their own handle design but they must care about a robust clamping connection between their handle and the control shaft and avoid overload of the shaft.
- Customers can connect two MDC's on a tandem unit in such a way that the actuation force will be transferred from the pilot control to the second control. The kinematic of the linkages must ensure that either control shaft is protected from torque overload.

Caution

Using the internal spring force on the input shaft is not an appropriate way to return the customer connection linkage to neutral, or to force a Bowden cable or a joystick back to neutral position. It is not applicable for any limitation of the Bowden cable stroke, except the applied torque to the shaft will never exceed 20 N·m.

Operation

MDC Torque

Description	Value
Torque required to move handle to maximum displacement	1.4 N•m [12.39 lbf•in]
Torque required to hold handle at given displacement	0.6 N•m [5.31 lbf•in]
Maximum allowable input torque	20 N•m [177 lbf•in]

! **Caution**

Volumetric efficiencies of the system will have impacts on the start and end input commands.

Neutral start switch (NSS)

The Neutral Start Switch (**NSS**) contains an electrical switch that provides a signal of whether the control is in neutral. The signal in neutral is Normally Closed (**NC**).

Neutral start switch schematic

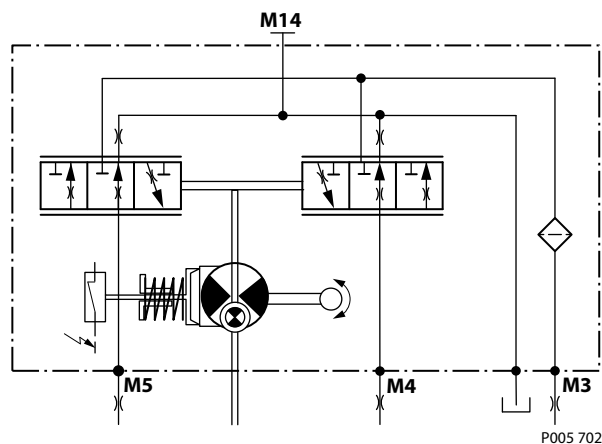

Neutral start switch data

Max. continuous current with switching	8.4 A
Max. continuous current without switching	20 A
Max. voltage	36 V _{DC}
Electrical protection class	IP67 / IP69K with mating connector

Case Gauge Port M14

The drain port should be used when the control is mounted on the unit's bottom side to flush residual contamination out of the control.

Control-Cut-Off (CCO) and Brake Release Valves

The H1 tandem pumps offer an optional **Control-Cut-Off** valve integrated into the pump center section and a separate brake release valve allowing the controls to be activated before activating any auxiliary functions.

The CCO valve shunts charge pressure from the pump controls allowing the servo springs to de-stroke both pumps. The valve is normally open for fail-safe operation. The solenoid must be energized for the pump to operate. When the machine control circuits energize the CCO solenoid, it connects charge supply from the charge gallery to the pump controls.

Operation

The 045/053 tandem also supplies charge pressure to the port X7 for auxiliary operation of devices such as spring applied/pressure released brakes. The control cut off valve also shunts pressure away from port X7.

The 060/068 tandem offers a separate brake release valve that operates independently of the CCO valve allowing the controls to be activated before activating any auxiliary functions. When the 60/68 brake valve is deactivated the X7 port shunts to case.

045/053 Tandem

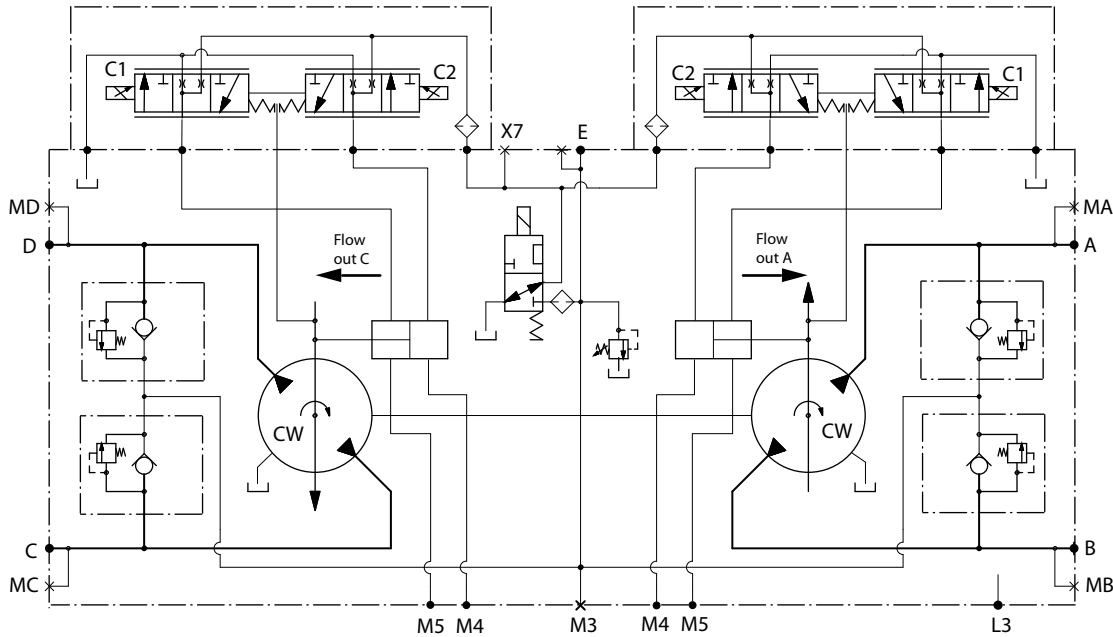

P106 148E

060/068 Tandem

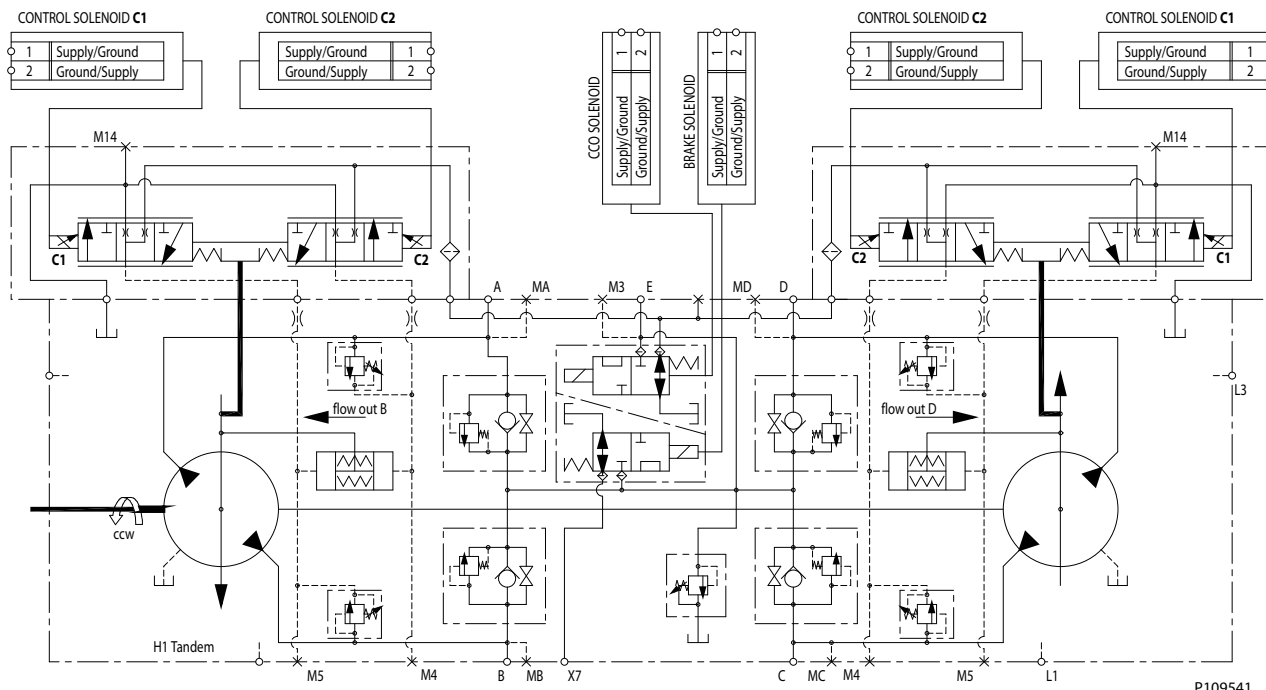

P109541

Operation

Solenoid data

Description		12 V	24 V
Minimum supply voltage		9 V _{DC}	18 V _{DC}
Maximum supply voltage (continuous)		16 V _{DC}	32 V _{DC}
IP Rating	IEC 60 529	IP 67	
	DIN 40 050, part 9	IP 69K with mating connector	
Pin connector		any order	

[For additional information, please contact Danfoss.](#)

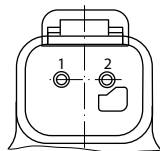

Operating Parameters

Input Speed

- Minimum speed** is the lowest input speed recommended during engine idle condition. Operating below minimum speed limits the pump's ability to maintain adequate flow for lubrication and power transmission.
- Rated speed** is the highest input speed recommended at full power condition. Operating at or below this speed should yield satisfactory product life.

Operating conditions between rated and maximum speed should be restricted to less than full power and to limited periods of time.
- Maximum speed** is the highest operating speed permitted. Exceeding maximum speed reduces product life and can cause loss of hydrostatic power and braking capacity. For most drive systems, maximum unit speed occurs during downhill braking or negative power conditions.

 **Warning**

Never exceed the maximum speed limit under any operating conditions.

During hydraulic braking and downhill conditions, the prime mover must be capable of providing sufficient braking torque in order to avoid pump over speed. This is especially important to consider for turbo-charged and Tier 4 engines.

For more information please see *Pressure and Speed Limits*, **BC152886484313**, when determining speed limits for a particular application.

Independent Braking System

Unintended vehicle or machine movement hazard. Exceeding maximum speed may cause a loss of hydrostatic drive line power and braking capacity. Machine manufacturer is responsible to provide a braking system, redundant to the hydrostatic transmission, sufficient to stop and hold the vehicle or machine in the event of hydrostatic drive power loss. The braking system must also be sufficient to hold the machine in place when full power is applied.

System Pressure

Hydraulic unit life depends on the speed and normal operating — or weighted average — pressure that can only be determined from a duty cycle analysis.

- System pressure** is the differential pressure between high pressure system ports. It is the dominant operating variable affecting hydraulic unit life. High system pressure, which results from high load, reduces expected life.
- Application pressure** is the high pressure relief or pressure limiter setting normally defined within the order code of the pump. This is the applied system pressure at which the drive line generates the maximum calculated pull or torque in the application.
- Maximum working pressure** is the highest recommended application pressure and is not intended to be a continuous pressure. Propel systems with application pressures at, or below this pressure should yield satisfactory unit life given proper component sizing. Application pressures above maximum working pressure will only be considered with duty cycle analysis and factory approval.

Pressure spikes are normal and must be considered when reviewing maximum working pressure.

Operating Parameters

Maximum pressure is the highest intermittent pressure allowed under any circumstances. Applications with applied pressures between rated and maximum require factory approval with complete application, duty cycle, and life expectancy analysis.

Minimum low loop pressure must be maintained under all operating conditions to avoid cavitation.

All pressure limits are differential pressures referenced to low loop (charge) pressure. Subtract low loop pressure from gauge readings to compute the differential.

Operating Parameters

Servo Pressure

Servo pressure is the pressure in the servo system needed to position and hold the pump on stroke. It depends on system pressure and speed. At minimum servo pressure the pump will run at reduced stroke depending on speed and pressure.

Minimum servo pressure at corner power holds the pump on full stroke at max speed and max pressure.

Maximum servo pressure is the highest pressure typically given by the charge pressure setting.

Charge Pressure

An internal charge relief valve regulates charge pressure. Charge pressure supplies the control with pressure to operate the swashplate and to maintain a minimum pressure in the low side of the transmission loop.

The charge pressure setting listed in the order code is the set pressure of the charge relief valve with the pump in neutral, operating at 1800 min^{-1} (rpm), and with a fluid viscosity of $32 \text{ mm}^2/\text{s}$ [150 SUS].

Pumps configured with no charge pump (external charge supply) are set with a charge flow of 30 l/min [7.93 US gal/min] and a fluid viscosity of $32 \text{ mm}^2/\text{s}$ [150 SUS].

The charge pressure setting is referenced to case pressure. Charge pressure is the differential pressure above case pressure.

Minimum charge pressure is the lowest pressure allowed to maintain a safe working condition in the low side of the loop. Minimum control pressure requirements are a function of speed, pressure, and swashplate angle, and may be higher than the minimum charge pressure shown in the Operating parameters tables.

Maximum charge pressure is the highest charge pressure allowed by the charge relief adjustment, and which provides normal component life. Elevated charge pressure can be used as a secondary means to reduce the swashplate response time.

Charge Pump Inlet Pressure

At normal operating temperature charge inlet pressure must not fall below rated charge inlet pressure (vacuum).

Minimum charge inlet pressure is only allowed at cold start conditions. In some applications it is recommended to warm up the fluid (e.g. in the tank) before starting the engine and then run the engine at limited speed.

Maximum charge inlet pressure may be applied continuously.

Case Pressure

Under normal operating conditions, the rated case pressure must not be exceeded. During cold start case pressure must be kept below maximum intermittent case pressure. Size drain plumbing accordingly.

The auxiliary pad cavity of axial pumps configured without integral charge pumps is referenced to case pressure. Units with integral charge pumps have auxiliary mounting pad cavities referenced to charge inlet (vacuum).

Possible component damage or leakage.

Operation with case pressure in excess of stated limits may damage seals, gaskets, and/or housings, causing external leakage. Performance may also be affected since charge and system pressure are additive to case pressure.

Operating Parameters

External Shaft Seal Pressure

In certain applications the input shaft seal may be exposed to external pressure. In order to prevent damage to the shaft seal the maximum differential pressure from external sources must not exceed 0.4 bar (5.8 psi) over pump case pressure.

The case pressure limits of the pump must also be followed to ensure the shaft seal is not damaged.

 **Caution**

Regardless of the differential pressure across the shaft seal, the shaft seal has been known to pump oil from the external source (e. g. gear box) into the pump case.

Temperature

The high temperature limits apply at the hottest point in the transmission, which is normally the motor case drain. The system should generally be run at or below the quoted **rated temperature**.

The **maximum intermittent temperature** is based on material properties and should never be exceeded.

Cold oil will generally not affect the durability of the transmission components, but it may affect the ability of oil to flow and transmit power; therefore temperatures should remain 16 °C [30 °F] above the pour point of the hydraulic fluid.

The **minimum temperature** relates to the physical properties of component materials.

Size heat exchangers to keep the fluid within these limits. Danfoss recommends testing to verify that these temperature limits are not exceeded.

Viscosity

For maximum efficiency and bearing life, ensure the fluid viscosity remains in the **recommended range**.

The **minimum viscosity** should be encountered only during brief occasions of maximum ambient temperature and severe duty cycle operation.

The **maximum viscosity** should be encountered only at cold start.

Technical Specifications

H1 Pumps General Specification

Axial piston closed circuit variable displacement pumps of cradle swash-plate design with clockwise or counterclockwise direction of rotation.

Pipe connections

- Main pressure ports: ISO split flange boss
- Main pressure ports H1P 045/053: SAE straight thread O-ring boss
- Main pressure ports H1P 060/068: ISO split flange boss
- Remaining ports: SAE straight thread O-ring boss

Recommended installation position

Pump installation position is discretionary, however the recommended control position is on the top or at the side with the top position preferred. If the pump is installed with the control at the bottom, flushing flow must be provided through port M14 located on the EDC, FNR and NFPE control.

Vertical input shaft installation is acceptable. If input shaft is at the top, 1 bar case pressure must be maintained during operation. The housing must always be filled with hydraulic fluid. Recommended mounting for a multiple pump stack is to arrange the highest power flow towards the input source. Consult Danfoss for nonconformance to these guidelines.

Auxiliary cavity pressure

Auxiliary cavity pressure will be inlet pressure with internal charge pump or case pressure with external charge supply. For reference see Operating Parameters. Please verify mating pump shaft seal capability.

Technical Data for H1 Tandem Pumps

Technical Data

Feature	Unit	045	053	060	068
Displacement	cm ³ [in ³]	45.0 [2.75]	53.8 [3.28]	60.4 [3.69]	68.0 [4.15]
Flow at rated (continuous) speed*	l/min [US gal/min]	153 [40]	183 [48]	210 [55.5]	238 [62.8]
Torque at maximum displacement (theoretical)	N·m/bar [lb·in/1000 psi]	0.8 [488]	0.9 [549]0.007 8 [0.00575]	0.96 [590]	1.08 [610]
Mass moment of inertia of rotating components	kg·m ² [slug·ft ²]	0.0077 [0.00568]	0.0078 [0.00575]	0.0143 [0.01055]	0.0143 [0.01052]
Mass (weight dry, without charge pump or auxiliary flange)	kg [lb]	65 [143]	65 [143]	96.2 [212]	96.2 [212]
Oil volume	l [US gal]	2.3 [0.61]	2.3 [0.61]	4.2 [1.1]	4.2 [1.1]

* Applies for each rotating group.

Physical properties

Description	045/053	060/068
Mounting flange per ISO 3019-1	Flange 101-2 (SAE B), special bolt	Flange 127-4 (SAE C)
Input shaft outer diameter, splines per ISO 3019-1	<ul style="list-style-type: none"> • Ø25 mm - 4 (SAE B-B, 15 teeth) • Ø32 mm - 4 (SAE-C, 14 teeth) • Ø31 mm - 4 (19 teeth) 	<ul style="list-style-type: none"> • Ø32 mm - 4 (SAE C, 14 teeth) • Ø35 mm - 4 (SAE C, 21 teeth)

Technical Specifications
Physical properties (continued)

Description	045/053	060/068
Auxiliary mounting flange with metric fasteners, shaft outer diameter and splines per ISO 3019-1	Flange 82-2 outer dia: • Ø16 mm - 4 (SAE A, 9 teeth) • Ø19 mm - 4 (SAE A, 11 teeth) Flange 101-2 outer dia: • Ø22 mm - 4 (SAE B, 13 teeth) • Ø25 mm - 4 (SAE B-B, 15 teeth)	Flange 101-2 outer dia: • Ø22 mm - 4 (SAE B, 13 teeth) • Ø25 mm - 4 (SAE B-B, 15 teeth)
Charge inlet port per ISO 11926-1	7/8 -14 (SAE O-ring boss)	1 1/16 -14 (SAE O-ring boss)
Main port configuration	ISO 11926-1: 1 5/16 -12 (SAE O-ring boss)	ISO 6162: M12 x 1.75 (Split flange)
Other ports	SAE O-ring boss	
Customer interface threads	Metric fasteners	

Operating parameters for H1 Tandem Pumps
Input Speed (at minimum charge/control pressure)

Description	Size 045/053	Size 060/068
Minimum for external charge supply ¹⁾	500 min ⁻¹ (rpm)	500 min ⁻¹ (rpm)
Rated	3400 min ⁻¹ (rpm)	3500 min ⁻¹ (rpm)
Maximum	3500 min ⁻¹ (rpm)	4000 min ⁻¹ (rpm)

¹⁾ Full performance (pressure and displacement) possible at minimum charge and control pressure supply.

System pressure

Description		Size 045	Size 053	Size 060	Size 068
System pressure	Max. working	420 bar [6092 psi]	380 bar [5511 psi]	420 bar [6090 psi]	380 bar [5510 psi]
	Maximum (peak)	450 bar [6527 psi]	400 bar [5802 psi]	450 bar [6525 psi]	400 bar [5800 psi]
	Max. low loop	45 bar [653 psi]		45 bar [650 psi]	
	Min. low loop	10 bar [145 psi]		10 bar [145 psi]	
Control pressure	Min. at corner power (EDC, MDC, FNR)	21.5 bar [312 psi]		18.5 bar [270 psi]	
	Maximum	40 bar [580 psi]		40 bar [580 psi]	

Other pressure type for all tandem pumps

Description	045-068	
Charge pressure	Minimum without CCO valve	14.5 bar [210 psi]
	Minimum with CCO valve	18 bar [265 psi]
	Maximum	34 bar [493 psi]
Case pressure	Rated	3.0 bar [44.0 psi]
	Maximum	5.0 bar [73.0 psi]
Lip seal external	Maximum	0.4 bar [5.8 psi]

Technical Specifications

Fluid Specification

Viscosity

Intermittent¹⁾	5 mm ² /s [42 SUS]
Minimum	7 mm ² /s [49 SUS]
Recommended range	12 – 80 mm ² /s [66 – 370 SUS]
Maximum	1600 mm ² /s [7500 SUS]

¹⁾ Intermittent = Short term t < 1 min per incident and not exceeding 2 % of duty cycle based load-life.

Temperature

Minimum¹⁾	-40°C [-40°F]
Rated	104°C [220°F]
Recommended range²⁾	60 – 85°C [140 – 185°F]
Maximum Intermittent	115°C [240°F]

¹⁾ Cold start = Short term t > 3 min, p ≤ 50 bar [725 psi], n ≤ 1000 min⁻¹ (rpm).

²⁾ At the hottest point, normally case drain port.

Fluid and Filter Maintenance Recommendations

To ensure optimum life perform regular maintenance of the fluid and filter. Contaminated fluid is the main cause of unit failure. Take care to maintain fluid cleanliness when servicing.

- Check the reservoir daily for proper fluid level, the presence of water, and rancid fluid odor. Fluid contaminated by water may appear cloudy or milky or free water may settle in the bottom of the reservoir. Rancid odor indicates the fluid has been exposed to excessive heat. Change the fluid and correct the problem immediately if these conditions occur.
- Inspect vehicle for leaks daily. Change the fluid and filter per the vehicle/machine manufacturer's recommendations or at intervals shown in the table. We recommend first fluid change at 500 hours.

Fluid and filter change interval

Reservoir type	Max oil change interval
Sealed	2000 hours
Breather	500 hours

[High temperatures and pressures will result in accelerated fluid aging. More frequent fluid changes may be required.](#)

- Change the fluid more frequently if it becomes contaminated with foreign matter (dirt, water, grease, etc.) or if the fluid is subjected to temperature levels greater than the recommended maximum.
- Dispose of used hydraulic fluid properly. Never reuse hydraulic fluid.
- Change filters with the fluid or when the filter indicator shows it's necessary.
- Replace all fluid lost during filter change.

Caution

Hydraulic fluid contains hazardous material.

Avoid contact with hydraulic fluid. Always dispose of used hydraulic fluid according to state and federal environmental regulations.

For further information see Danfoss publication *Technical Information, Hydraulic Fluids and Lubricants, BC0000093*.

Pressure Measurements

Port locations and gauge installation - 045/053

The following table and drawings show the port locations and gauge sizes needed. When testing system pressures, calibrate pressure gauges frequently to ensure accuracy. Use snubbers to protect gauges.

Port information

Port identifier	Port size	Wrench size	Reading	Gauge size, bar [psi]
L1, L2, L3	1 1/16-12 UNF 2B	9/16 internal hex	Case drain	10 bar [100 psi]
MA, MB, MC, MD	9/16-18 UNF	1/4 internal hex	System pressure	600 bar [10,000 psi]
M3	9/16-18 UNF 2B	1/4 internal hex	Charge pressure	50 bar [1000 psi]
M4, M5	7/16-20 UNF 2B	3/16 internal hex	Servo pressure	50 bar [1000 psi]
AM3	9/16-18 UNF 2B	1/4 internal hex	Alternate Charge pressure	50 bar [1000 psi]
A, B, C, D	1 5/16-12	-	System ports	-
E	7/8-14	-	Charge filtration	-
M14	7/16-20	1/4 internal hex	Case gauge port	10 bar [100 psi]

Port locations

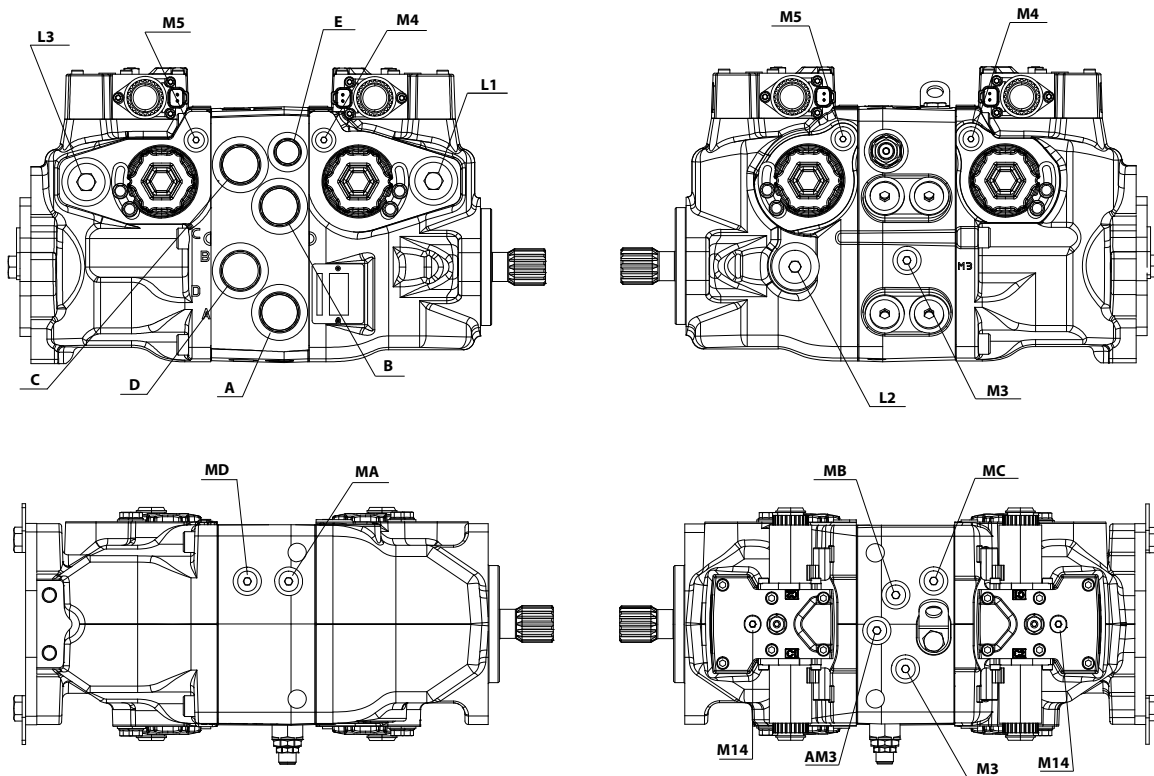

P109117

Pressure Measurements

Port locations and gauge installation - 060/068

Port information

Port identifier	Port size	Wrench size	Reading	Gauge size, bar [psi]
L1, L2, L3	1 1/16-12 UNF 2B	9/16 internal hex	Case drain	10 bar [100 psi]
MA, MB, MC, MD	9/16-18 UNF	1/4 internal hex	System pressure	600 bar [10,000 psi]
M3, AM3	9/16-18 UNF 2B	1/4 internal hex	Charge pressure	50 bar [1000 psi]
M4, M5	7/16-20 UNF 2B	3/16 internal hex	Servo pressure	50 bar [1000 psi]
M14	7/16-20	3/16 internal hex	Case gauge port	10 bar [100 psi]
A, B, C, D	1 5/16-12	-	System ports	-
E	7/8-14	-	Charge filtration	-

Port locations

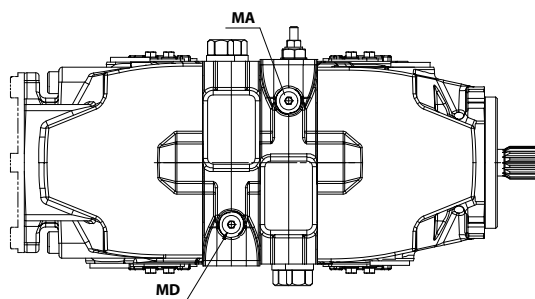
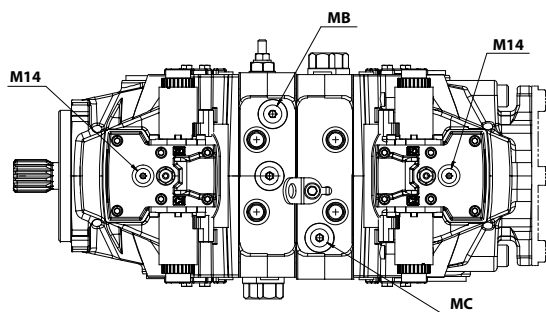
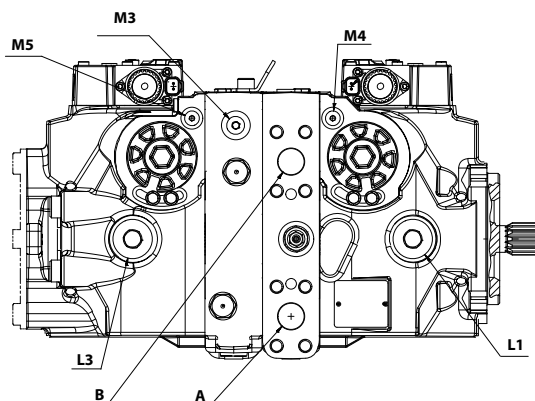
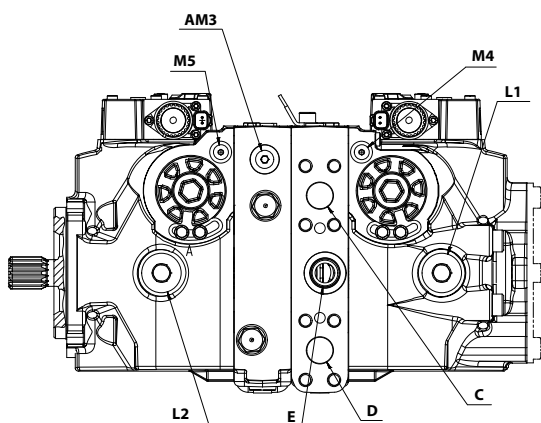

P109185

Initial Startup Procedures

Start-Up Procedure

Prior to installing the pump, inspect for damage that may have occurred during shipping.

Follow this procedure when starting-up a new pump installation or when restarting an installation in which the pump has been removed and re-installed on a machine. Ensure pump has been thoroughly tested on a test stand before installing on a machine.

! Caution

M12X1.75 or ½" screws with hardened washer (ASTM F436M or ISO 7089 300HV) must be used to mount the pump. Using M14 screws may cause issues when mounting.

1. Ensure that the machine hydraulic oil and system components (reservoir, hoses, valves, fittings, and heat exchanger) are clean and free of any foreign material.
2. Install new system filter element(s) if necessary. Check that inlet line fittings are properly tightened and there are no air leaks.
3. Install the pump and a 50 bar [1000 psi] gauge in the charge pressure gauge port M.
4. Fill the housing by adding filtered oil in the upper case drain port.
If the control is installed on top, open the construction plug in the top of the control to assist in air bleed.
5. Fill the reservoir with hydraulic fluid of the recommended type and viscosity; fill inlet line from reservoir to pump.
Use a 10-micron filler filter.
6. Disconnect the pump from all control input signals.

Do not disconnect a FDC control from control input signals. Due to the fail safe function the pump will stroke in case of sufficient servo pressures. During start up provide a signal to keep the pump in neutral.

7. Close construction plug removed in the step 4.

! Caution

After start-up the fluid level in the reservoir may drop due to system components filling. Damage to hydraulic components may occur if the fluid supply runs out. Ensure reservoir remains full of fluid during start-up. Air entrapment in oil under high pressure may damage hydraulic components. Check carefully for inlet line leaks. Do not run at maximum pressure until system is free of air and fluid has been thoroughly filtered.

8. Use a common method to disable the engine to prevent it from starting.
9. Crank the starter for several seconds.

! Caution

Do not to exceed the engine manufacturer's recommendation. Wait 30 seconds and then crank the engine a second time as stated above.

This operation helps to remove air from the system lines.

10. Refill the reservoir to recommended fluid level.
11. When the gauge begins to register charge pressure, enable and start engine.
Let the engine run for a minimum of 30 seconds at low idle to allow the air to work itself out of the system.
12. Check for leaks at all line connections and listen for cavitation.
13. Check for proper fluid level in the reservoir.
14. Increase engine speed to normal operating rpm to further purge residual air from the system, when adequate charge pressure is established (as shown in model code).
15. Shut off the engine.
16. Connect pump control signal.

Initial Startup Procedures

- 17.** Start engine, checking to be certain pump remains in neutral. Run engine at normal operating speed and carefully check for forward and reverse control operation.
- 18.** Continue to cycle between forward and reverse for at least five minutes to bleed all air and flush system contaminants out of the system loop.

Normal charge pressure fluctuation may occur during forward and reverse operation.

- 19.** Check that the reservoir is full and remove charge pressure gauge.
The pump is now ready for an operation.

Troubleshooting

This section provides troubleshooting steps to follow if you are having problems with your machine until you solve the problem. Some of the troubleshooting items are system specific. Always observe the safety precautions listed in the Introduction section and precautions related to your specific equipment.

Safety Precautions

Always consider safety precautions before beginning a service procedure. Protect yourself and others from injury. Take the following general precautions whenever servicing a hydraulic system.

High Inlet Vacuum

High inlet vacuum causes cavitation which can damage internal pump components.

Unintended machine movement

Unintended movement of the machine or mechanism may cause injury to the technician or bystanders. Secure the machine or disable/disconnect the mechanism while servicing to protect against unintended movement.

Independent Braking System

Unintended vehicle or machine movement hazard. Exceeding maximum speed may cause a loss of hydrostatic drive line power and braking capacity.

Machine manufacturer is responsible to provide a braking system, redundant to the hydrostatic transmission, sufficient to stop and hold the vehicle or machine in the event of hydrostatic drive power loss. The braking system must also be sufficient to hold the machine in place when full power is applied.

Manufacturer's Warranty

Contamination can damage internal components and void the manufacturer's warranty. Take precautions to ensure system cleanliness when removing and installing system lines.

Fluid Under Pressure

Escaping hydraulic fluid under pressure can have sufficient force to penetrate your skin causing serious injury and/or infection. This fluid may also be hot enough to cause burns.

Relieve pressure in the system before removing hoses, fittings, gauges, or components. Never use your hand or any other body part to check for leaks in a pressurized line. Use caution when dealing with hydraulic fluid under pressure. Seek medical attention immediately if you are cut by hydraulic fluid.

Flammable cleaning solvents

Some cleaning solvents are flammable.

Do not use cleaning solvents in an area where a source of ignition may be present to avoid possible fire.

Personal safety

Protect yourself from injury whenever servicing a hydraulic system.

Use proper safety equipment, including safety glasses, at all times.

Hazardous material

Hydraulic fluid contains hazardous material.

Avoid prolonged contact with hydraulic fluid. Always dispose of used hydraulic fluid according to state, and federal environmental regulations.

Troubleshooting

Electrical Troubleshooting

Electrical troubleshooting

Item	Description	Action
Control operates pump in one direction only.	Control coil failure	<ul style="list-style-type: none"> • Measure resistance at coil pins. Resistance should be 14.20 Ω (24V) or 3.66 Ω (12V) at 20°C [70°F]. • Replace coil.
No pump function	No power to controller	Restore power to controller.
Erratic pump function	Electrical connection to pump is bad.	Disconnect connection, check wires, reconnect wires.
Filter bypass indicator switch	Filter switch may be bad.	<ul style="list-style-type: none"> • Check/replace filter switch. • Add gauge to filter bypass port to verify proper fluid flow and verify switch operation by measuring resistance. <ul style="list-style-type: none"> – Open resistance \geq 510 Ω – Closed resistance \leq 122 Ω
Erratic or no machine function	External controller malfunction or hydraulic system problem.	<ul style="list-style-type: none"> • Verify external controller problem using spare controller. • Replace controller. • Check hydraulic system fluid level/pressures/filters/etc. • Fix hydraulic system problems.

Use a manual override to check proper pump operation and verify electrical problem, if available.

Integral Filter Bypass

Item	Description	Action
Filter bypass activated	Filter is plugged causing fluid to bypass filter.	Replace filter. Check that bypass switch indicates proper operation after filter is replaced.
Filter bypass indicator switch	Filter bypass indicator switch is indicating wrong bypass situation.	Check/replace filter switch. <ul style="list-style-type: none"> • Open resistance \geq 510 Ω • Closed resistance \leq 122 Ω

Neutral Difficult or Impossible to Find

Item	Description	Action
Input to pump control	Input to control module is operating improperly	Disconnect input and check to see if pump comes back to neutral. <ul style="list-style-type: none"> • If Yes – input fault, replace or repair external controller • If No – go to next step
Neutral	Neutral set improper	Shunt servo gauge ports (M4 and M5) together with external hose and see if pump comes back to neutral. <ul style="list-style-type: none"> • If Yes – Control neutral improperly set (see Control Neutral Adjustment on page 51). • If neutral is still impossible to set, balance the swashplate (see Mechanical Neutral Adjustment on page 53). • If you still cannot set neutral, replace the control.

Transmission Operates Normally in One Direction Only

Item	Description	Action
Input to pump control.	Input to control module is operating improperly.	Check control input and repair or replace as necessary.
Control orifices	Control orifice(s) are blocked.	Clean control orifices.
Control screens	Control screen(s) are blocked.	Replace control screens. Only a Danfoss Authorized Service Center may remove the unit's endcap without voiding the warranty.

Troubleshooting

Item	Description	Action
Exchange system pressure limiters	Exchanging the pressure limiter valves will show if the problem is related to the valve function.	If the problem changes direction, replace the valve that does not operate correctly.
Exchange high pressure relief valves	Exchanging the high pressure relief valves will show if the problem is related to the valve function.	If the problem changes direction, replace the valve that does not operate correctly.
Servo pressure low or decaying	Damaged servo seals may prevent servo piston from stroking the pump.	Check for torn/missing servo seals. Replace and retest. Only a Danfoss Authorized Service Center may remove the servo piston without voiding the warranty.
Bypass function open	Open bypass will cause one or both directions to be inoperative.	Close bypass function.

System Operating Hot

Item	Description	Action
Oil level in reservoir	Insufficient hydraulic fluid will not meet cooling demands of system.	Fill reservoir to proper level.
Heat exchanger	Heat exchanger is not sufficiently cooling the system.	<ul style="list-style-type: none"> • Check air flow and input air temperature for heat exchanger • Clean, repair or replace heat exchanger
Charge pressure	Low charge pressure will overwork system.	<ul style="list-style-type: none"> • Measure charge pressure. • Inspect and adjust or replace charge relief valve. • Inspect charge pump; repair or replace charge pump.
Charge pump inlet vacuum	High inlet vacuum will overwork system. A dirty filter will increase the inlet vacuum. Inadequate line size will restrict flow.	<ul style="list-style-type: none"> • Check charge inlet vacuum. If high, inspect inlet filter and replace as necessary • Check for adequate line size, length or other restrictions
System relief pressure settings	If the system relief valves are worn, contaminated, or valve settings are too low, the relief valves will be overworked.	Verify settings of pressure limiters and high pressure relief valves and adjust or replace valves as necessary.
System pressure	Frequent or long term operation over system relief setting will create heat in system.	Measure system pressure. If pressure is too high, reduce loads.

System Will Not Operate in Either Direction

Item	Description	Action
Oil level in reservoir.	Insufficient hydraulic fluid to supply system loop.	Fill reservoir to proper level.
Pump control orifices	Control orifices are blocked.	Clean control orifices.
Pump control screens	Control screens are blocked.	Replace control screens. Only a Danfoss Authorized Service Center may remove the unit's endcap without voiding the warranty.
Bypass function open	If bypass function is open, the system loop will be depressurized.	Close bypass valves. Replace high pressure relief valve if defective.
Low charge pressure with pump in neutral	Low charge pressure insufficient to recharge system loop.	Measure charge pressure with the pump in neutral. If pressure is low, go to Pump charge relief valve.
Low charge pressure with pump in stroke	Low charge pressure resulting from elevated loop leakage. Insufficient control pressure to hold pump in stroke.	Deadhead the pump to isolate it from the motor. With pump in partial stroke and engaged for only a few seconds, check pump charge pressure. Low charge pressure indicates a malfunctioning pump. Continue to next step. Good charge pressure indicates a malfunctioning motor or other system component. Check motor charge relief operation (if present).
Pump charge relief valve	A pump charge relief valve that is leaky, contaminated, or set too low will depressurize the system.	Adjust or replace pump charge relief valve as necessary.
Charge pump inlet filter	A clogged filter will under supply system loop.	Inspect filter and replace if necessary.

Troubleshooting

Item	Description	Action
Charge pump	A malfunctioning charge pump will provide insufficient charge flow.	Repair or replace the charge pump.
System pressure	Low system pressure does not provide enough power to move load.	Measure system pressure. Continue to next step.
High pressure relief or pressure limiter valves	Defective high pressure relief or pressure limiter valves cause system pressure to be low.	Repair or replace high pressure relief or pressure limiter valves.
Input to control	Input operating improperly	Repair/replace control.

System Noise or Vibration

Item	Description	Action
Reservoir oil level	Low oil level leads to cavitation.	Fill reservoir.
Aeration of the oil/pump inlet vacuum	Air in system decreases efficiency of units and controls. Excessive noise, foaming oil, and hot oil all indicate air in system.	Find location where air is entering into the system and repair. Check that inlet line is not restricted and is proper size.
Cold oil	If oil is cold, it may be too viscous for proper function and pump cavitates.	Allow the oil to warm up to its normal operating temperature with engine at idle speed.
Pump inlet vacuum	High inlet vacuum causes noise/cavitation.	Check that inlet line is not restricted and is of proper size. Check filter and bypass switch.
Shaft couplings	A loose shaft coupling will cause excessive noise.	Replace loose shaft coupling..
Shaft alignment	Misaligned shafts create noise.	Align shafts.
Charge/system relief valves	Unusual noise may indicate sticking valves and possible contamination.	Clean/replace valves and test pump.

Sluggish System Response

Item	Description	Action
Oil level in reservoir	Low oil level causes sluggish response.	Fill reservoir.
High pressure relief valves/ pressure limiter settings	Incorrect pressure settings affects system reaction time.	Adjust or replace high pressure relief valves.
Low prime mover speed	Low engine speed reduces system performance.	Adjust engine speed.
Charge pressure	Incorrect pressure affects system performance.	Measure and adjust charge pressure relief or replace charge pump.
Air in system	Air in system produces sluggish system response.	Fill tank to proper level. Cycle system slowly for several minutes to remove air from system.
Contaminated control orifices	Control orifices are plugged.	Clean control orifices.
Contaminated control screens	EDC supply screen is plugged.	Replace control screens. Only a Danfoss Authorized Service Center may remove the unit's endcap without voiding the warranty.
Pump inlet vacuum	Inlet vacuum is too high resulting in reduced system pressure.	Measure charge inlet vacuum. Inspect line for proper sizing. Replace filter. Confirm proper bypass operation.

Adjustments

This section offers instruction on inspection and adjustment of pump components. Read through the entire topic before beginning a service activity.

Refer to [Pressure Measurements](#) on page 32 for location of gauge ports and suggested gauge size.

Standard Procedures

1. Ensure the surrounding area is clean and free of contaminants like dirt and grime.
2. With the prime mover off, thoroughly clean the outside of the pump.
3. Tag each hydraulic line, if removing the pump.
4. When you disconnect hydraulic lines, cap them and plug each open port to prevent contamination.
5. Inspect the system for contamination.
6. Check the hydraulic fluid for signs of contamination: oil discoloration, foam in the oil, sludge, or metal particles.
7. If there are signs of contamination in the hydraulic fluid, replace all filters and drain the hydraulic system.
8. Flush the lines and refill the reservoir with the correct filtered hydraulic fluid.
9. Before re-installing the pump, test for leaks.

Adjustments

Charge Pressure Relief Valve Adjustment

Operate the system with the pump in neutral (zero displacement) when measuring charge pressures.

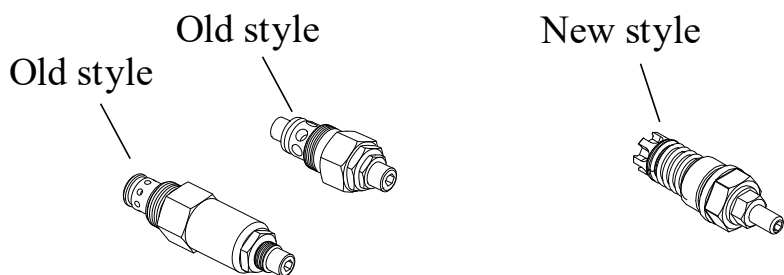

P109549

This procedure explains how to check and adjust the charge pressure relief valve.

Charge pressure adjustment

060/068

045/053

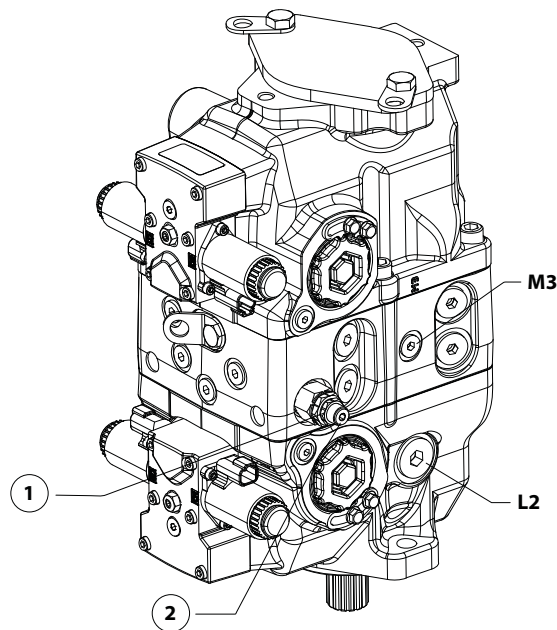
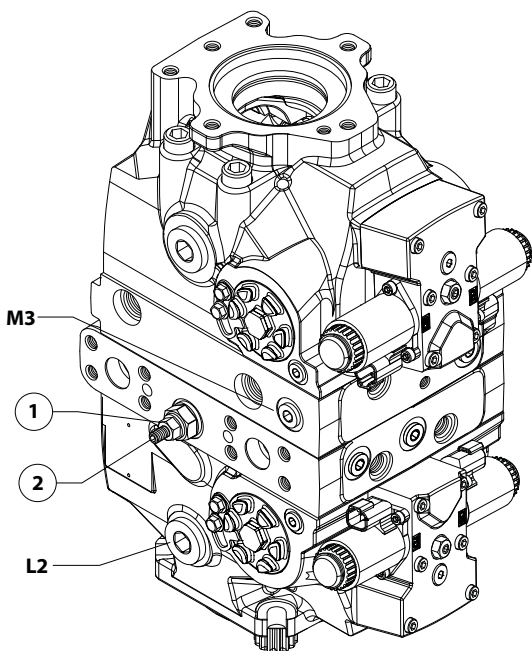

P109550

Lock nut, wrench size 19 mm, torque 40 N·m [29.5 lb·ft] (pos. 1)

Adjusting screw, wrench size 6 mm (pos. 2)

Adjustments

Item	Port description	Wrench size	Torque	Gauge size
M3	Charge pressure gauge	¼ in	24 N•m [17 lb•ft]	0–50 bar [0–1000 psi]
L2	Case drain	9/16 in (045/053)	48.5 N•m [35.8 lb•ft] (045/053)	0–10 bar [0–100 psi]
		5/8 in (060/068)	148 N•m [109 lb•ft] (060/068)	

See [Fastener Size and Torque Chart](#) on page 77 for torques and wrench sizes on other charge pressure relief valves.

1. Install a 50 bar [1000 psi] pressure gauge in charge pressure gauge port M3.
2. Install a 10 bar [100 psi] gauge at case pressure port L1, L2, or L3.

The table below shows the acceptable pump charge pressure range for some nominal charge relief valve settings (refer to model code located on serial number plate).

Charge pressure range setting

Current code	20	22	24	26	28	30	32	34	NA
Old code	BK	BB	BD	BF	BH	CK	CB	NA	CD
Pressure setting	20 ± 1.5 bar [290 ± 21.8 psi]	22 ± 1.5 bar [319 ± 21.8 psi]	24 ± 1.5 bar [348 ± 21.8 psi]	26 ± 1.5 bar [377 ± 21.8 psi]	28 ± 1.5 bar [406 ± 21.8 psi]	30 ± 1.5 bar [435 ± 21.8 psi]	32 ± 1.5 bar [464 ± 21.8 psi]	34 ± 1.5 bar [493 ± 21.8 psi]	36 ± 1.5 bar [522 ± 21.8 psi]

Listed pressures assume a pump speed of 1800 min⁻¹ (rpm), a reservoir temperature of 50°C [120°F], and charge flow of 30 l/min [7.9 US gal/min]; referenced to case pressure. At higher pump speeds or higher charge flows the charge pressure will rise over the rated setting.

3. Loosen the locknut and rotate the adjusting screw clockwise to increase the setting; or counterclockwise to decrease it.
4. Subtract the case pressure reading to compute the actual charge pressure.

[Pressure change per turn is dependent on charge flow entering pump.](#)

5. While holding the adjusting screw, torque locknut to 40 N•m [30 lbf•ft].
6. When you achieve the desired charge pressure setting, remove the gauges and plug the ports.

Adjustments

Charge check / HPRV adjustment

The charge check/HPRV combines the charge check and high pressure relief functions. Whenever you replace a charge check/HPRV, operate the vehicle/machine through its full range of functions to ensure proper pump operation. The charge check/HPRVs are preset at the factory, no adjustment is possible.

Checking for proper charge check / HPRV operation

If you suspect charge check/HPRV malfunction, swap valves and test operation. If the symptoms switch direction, replace the faulty valve.

Adjustments

Pressure Limiter

Pressure Limiter Screens

⚠ Warning

Pumps with only HPRV valves no longer contain pressure limiter (PL) screens and retainer. To convert the pumps to use pressure limiter valves, please contact your Danfoss Service Partner. Pumps that have PL valves without PL screens and retainers are at high risk of contamination and product malfunction.

H1P Base Models with pressure settings option B include PL screens and retainers.

Pressure Limiter Adjustment (060/068 only)

Lock motor output shaft to adjust the pressure limiter setting. Lock the vehicle's brakes or rigidly fix the work function so it cannot rotate.

Ensure charge pressure is properly set before checking pressure limiter.

Pressure limiter adjustment

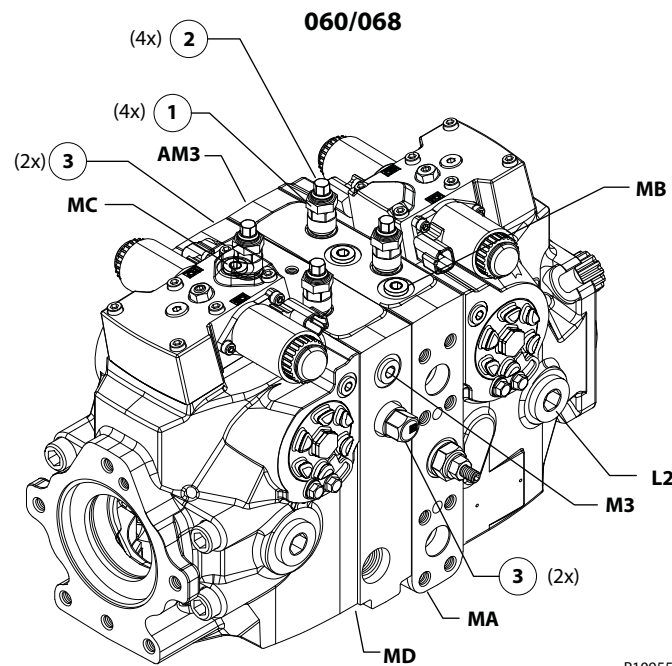

P109551

Legend

Item	Description	Wrench size	Torque	Gauge size
1	Lock nut	14 mm	20 N•m [15 lb•ft]	-
2	Adjusting screw	6 mm	-	-
3	HPRV Valve	22 mm	70 N•m [52 lb•ft]	-
M3, AM3	Charge pressure gauge port	¼ inch	43 N•m [32 lb•ft]	0 - 50 bar [0 - 1000 psi]
L2	Case drain port	5/8 inch	148 N•m [109 lb•ft]	0 - 10 bar [0 - 100 psi]
MA, MB, MC, MD	System pressure gauge ports	¼ inch	43 N•m [32 lb•ft]	0 - 600 bar [0 - 10,000 psi]

Endcaps are different for clockwise and counter clockwise rotation.

Adjustments

PL valve adjustment Clockwise

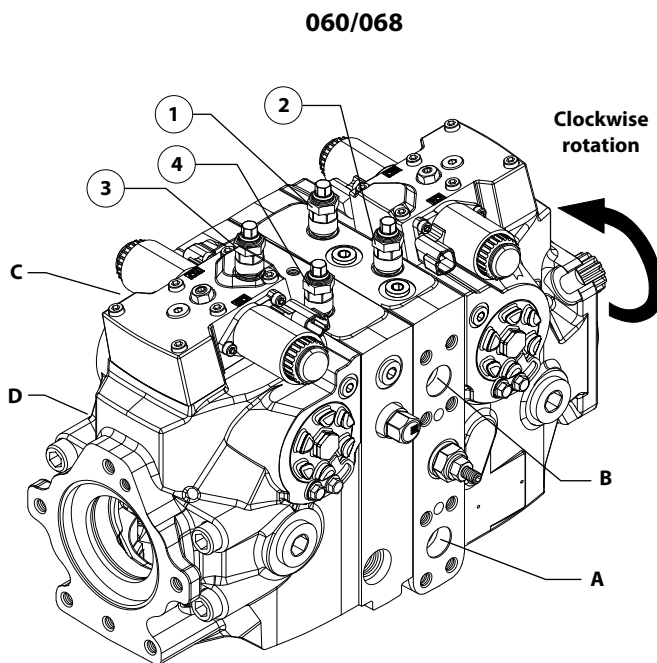

P109552

Legend:

Controls pressure ports: **B = 1, A = 2, C = 3, D = 4**
 Lock nut torque = 20 Nm [15 lb-ft]

PL valve adjustment Counterclockwise

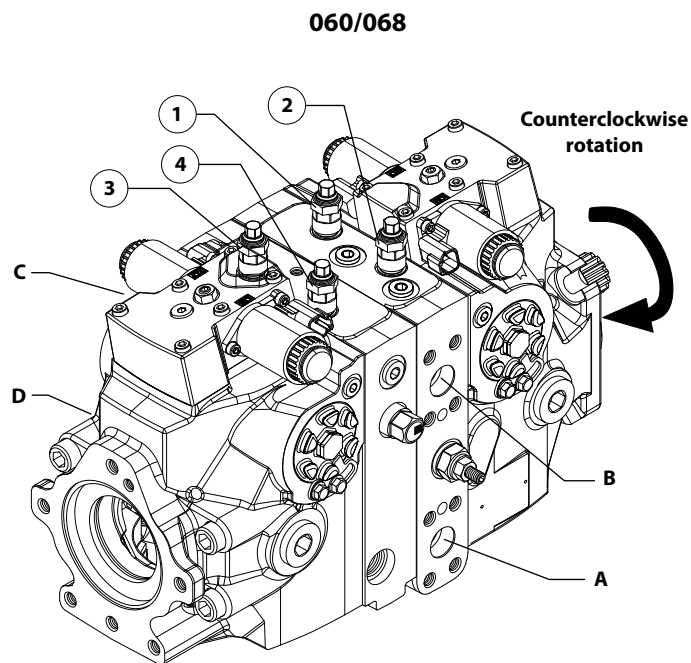

P109553

Legend:

Controls pressure ports: **A = 1, B = 2, D = 3, C = 4**
 Lock nut torque = 20 Nm [15 lb-ft]

If you change pressure limiter settings, you must also change the HPRV valve to maintain proper PL function. Refer to table below for corresponding settings.

Pressure limiter setting (bar)

PL setting	150	180	200	230	250	280	300	330	350	380	400	430	460
											410	440	470
											420	450	480
HPRV setting	200	230	250	280	300	330	350	380	400	420	450	480	510

1. Install 600 bar [10 000 psi] pressure gauges in the high pressure gauge ports (MA and MB).
2. Install a 50 bar [1000 psi] pressure gauge in the charge pressure gauge port (M3).

Ensure charge pressure is properly set before checking pressure limiter.

3. Start the prime mover and operate at normal speed.
4. Use a 17 mm wrench to loosen the locking nut (L024).
5. Activate the control input until pressure in the high side of the system loop stops rising. This pressure is the PL setting.
6. Return the pump to neutral and adjust the PL setting using an internal hex wrench. Wrench size is in the diagram on the previous page.
7. Turn the adjusting screw clockwise to increase the PL setting, counter clockwise to decrease it.

The adjustment is very sensitive. Change per turn is 90 bar [1305 psi].

The model code on the serial plate gives the factory setting of the PL (Pressure Limiter). The PL setting is referenced to charge pressure. Subtract charge pressure from system pressure gauge readings to compute the effective PL setting.

8. Repeat steps 4. and 5. until you reach the desired PL setting.

Adjustments

9. After adjustment, torque the locknut (L024) to 12 N·m [9 lbf·ft].

 **Caution**

Do not over torque.

10. Shut down the prime mover.
11. Remove gauges and replace plugs.

Adjustments

Charge check / HPRV adjustment

The charge check/HPRV combines the charge check and high pressure relief functions. Whenever you replace a charge check/HPRV, operate the vehicle/machine through its full range of functions to ensure proper pump operation. The charge check/HPRVs are preset at the factory, no adjustment is possible.

Checking for proper charge check / HPRV operation

If you suspect charge check/HPRV malfunction, swap valves and test operation. If the symptoms switch direction, replace the faulty valve.

Adjustments

Engaging the Bypass Function

It is possible to damage the drive motor(s) by operating in bypass mode without charge pressure. Move the vehicle/machine at a speed not more than 20% of maximum for a duration not exceeding 3 minutes.

Use this procedure to bypass the pump (frame size 060/068 only) to allow moving the vehicle/machine short distances when you cannot start the prime mover.

Engaging the Bypass Function

060/068

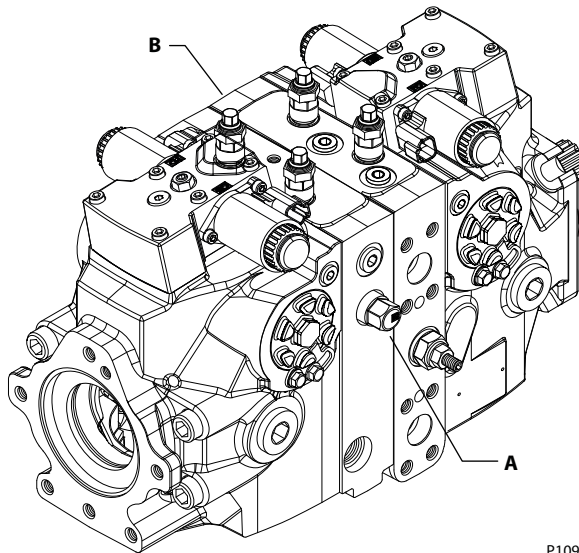

P109554

1. To open the HPRVs (L150), rotate three revolutions counterclockwise using a hex wrench.

⚠ Caution

Do not rotate more than 3 revolutions, leakage will result.

2. Rotate them clockwise until seated to close the HPRVs.
See the following table for torque values:

HPRV Wrench Size and Torque Value

Frame size	Wrench size	Torque
045—100	22 mm	70 N•m [52 lbf•ft]
060—068	22 mm	70 N•m [52 lbf•ft]
115—280	30 mm	110 N•m [81 lbf•ft]

If machine is towable with HPRVs opened three turns and if wheels are locked (not towable) with HPRV valves closed, bypass function is working correctly.

Adjustments

Displacement Limiter Adjustment for Tandem Pumps

An optional displacement limiter is located on each side of the pump housing. The maximum displacement can be limited in either direction.

Displacement limiters are not pre-set by the factory but are installed to minimize the extension of the adjustment screw while not limiting the maximum displacement of the pump. A small amount of clockwise screw adjustment is required before the 100% displacement condition is reached.

! **Caution**

Before adjusting the displacement limiter, mark the position of the servo cylinder.

Displacement limiter adjustment

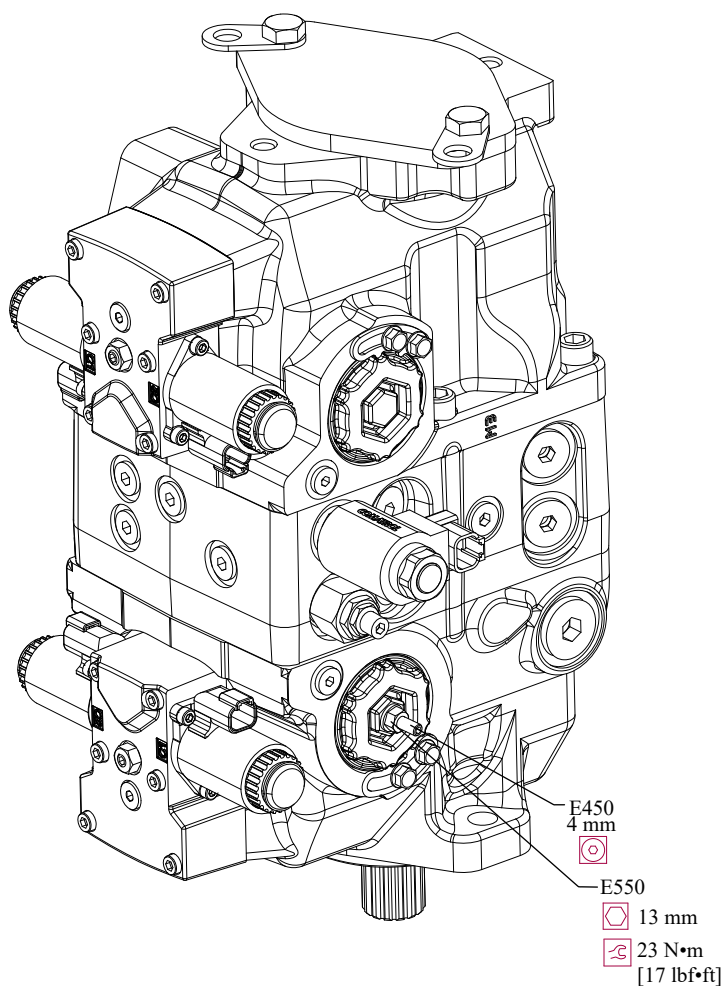

P106 144E

Adjustments

1. Loosen the locknut (E550).

Lock nut wrench size is 13 mm and torque is 23 N•m [17 lbf•ft] (for all tandem pumps).

2. Rotate the adjusting screw (E450).

Adjusting screw wrench size is 4 mm. Rotating the adjusting screw clockwise decreases the maximum displacement of the pump while rotating the adjusting screw counterclockwise increases the maximum displacement.

3. After establishing the desired maximum displacement setting, hold adjusting screw in place and tighten the locknut.

Refer to the table for change per turn. Clockwise rotation decreases displacement, counterclockwise rotation increases it. Adjustment is possible from zero to maximum.

 **Caution**

Be sure servo cylinder does not rotate when displacement limiter locknut (E550) is torqued.

Approximate displacement change per revolution of adjusting screw

Unit	045	053	060	068
cm ³ [in ³]	5.1 [0.311]	6.0 [0.366]	5.9 [0.360]	6.6 [0.403]

Adjustments

Control Neutral Adjustment

All functions of the Electric Displacement Control (EDC), are preset at the factory. If necessary, adjust the pump to neutral with the pump running on a test stand or on the vehicle/machine with the prime mover operating. If adjustment fails to give satisfactory results, you may need to replace the control or coils. See Minor repair for details.

Control neutral adjustment

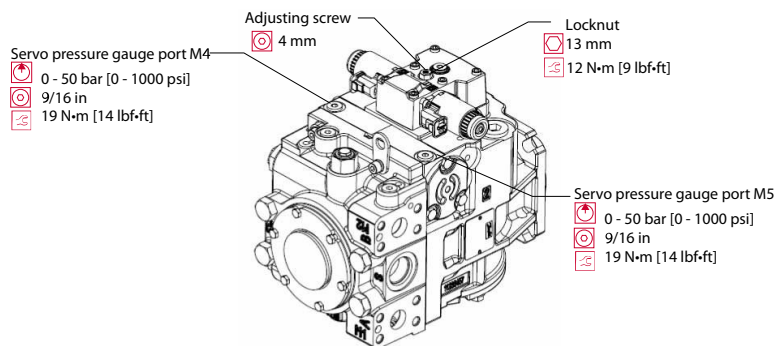

P106 343E

1. Install a 50 bar [1000 psi] gauge in each of the two servo gauge ports (M4 and M5).
2. Disconnect the external control input (electrical connections) from the control.
3. Start the prime mover and operate at normal speed.
4. Use a 4 mm internal hex wrench to hold the neutral adjusting screw (D015) stationary while loosening the locknut (D060) with a 13 mm wrench.
5. Observe pressure gauges and if necessary, turn adjusting screw (D015) to reduce pressure differential.

Adjustment of the EDC is very sensitive. Be sure to hold the hex wrench steady while loosening the locknut. Total adjustment is less than 120 degrees.

Neutral Adjustment (EDC) (bottom view)

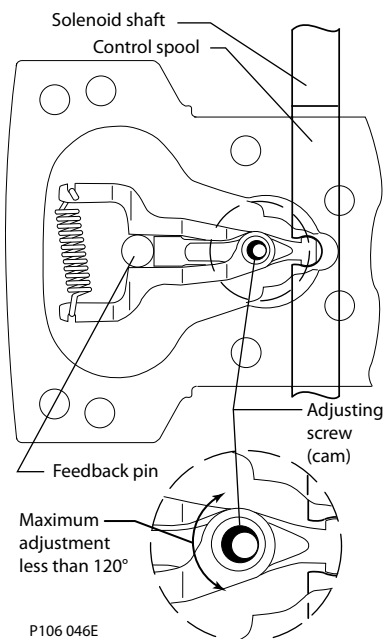

P106 046E

Illustration shows how cam on adjusting pin rotates to adjust for neutral position after pump is re-installed.

Adjustments

6. Rotate the neutral adjusting screw clockwise until the pressure increases on the gauge.

Note the angular position of the wrench.

7. Rotate the neutral adjusting screw counterclockwise until the pressure increases by an equal amount on the other gauge.

Note the angular position of the wrench.

8. Rotate the neutral adjusting screw clockwise half the distance between the wrench positions noted above.

The gauges should read the same pressure, indicating that the control is in its neutral position.

9. Hold the neutral adjusting screw stationary and tighten the locknut (D060). Torque to 10 N·m [9 lbf·ft] 12 N·m [9 lbf·ft].

 **Caution**

Do not over torque.

10. When the neutral position is set, stop the prime mover and remove the gauges.

11. Install the gauge port plugs.

12. Reconnect the external control input.

A small pressure differential of 1.5 bar [22 psi] or less is acceptable. Zero differential is usually not possible.

Adjustments

Mechanical Neutral Adjustment

Mechanical neutral is set with the pump running at 1800 min⁻¹(rpm). To set neutral, you must stroke the pump in each direction. The procedure is the same for each side of each pump for both the front and rear sections.

You can do this with a small movement of the eccentric screw on EDC controls, however non-feedback controls (NFPE/FNR) lack this mechanism. To stroke a pump with non-feedback control, you must provide a 100 Hz PWM signal to the control solenoids. If you perform this adjustment with the pump installed in a vehicle or machine, safely elevate the wheels or disconnect the mechanism to allow safe operation during adjustment.

This procedure details setting neutral for the entire pump, one side at a time. Alternate M4/M5 and MA/MB to zero out forward and reverse directions of the front unit, then move the gauges to M4/M5 of the rear unit and MC/MD (system gauge ports for the rear unit). Refer to the drawing on the next page to identify all ports. The front and rear sections are basically mirror images of each other. The control solenoids C1 and C2 are marked on each control.

While performing this adjustment, you monitor the following pressures:

- Servo pressure at M4 and M5
- System pressure at MA and MB or MC and MD
- Pressure differential between M4 and M5 (optional)
- Pressure differential between A and B or MC and MD (optional)

Unintended machine movement

Unintended movement of the machine or mechanism may cause injury to the technician or bystanders. Secure the machine or disable/disconnect the mechanism while servicing to protect against unintended movement.

Pump setup

1. Attach a 50 bar [1000 psi] gauge to each servo pressure port M4 and M5.
2. Attach a 600 bar [10 000 psi] gauge to each system pressure port (MA and MB for front pump, MC and MD for rear pump).
3. Remove servo cylinder locking screws (E350) and plates (E300) from both sides of the pump.
4. Disconnect the control solenoids from the vehicle wiring harness.
5. If using a PWM signal to set mechanical neutral, connect the control solenoids C1 and C2 to the signal source. Ensure the source supplies no current to the solenoids until required in the following procedure.

Adjustments

Servo Adjustment for Tandem Pumps

Servo and system pressure gauge port locations (045/053)

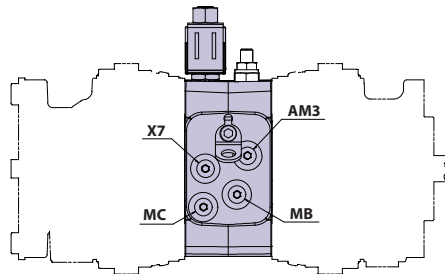

Control Cutoff (CCO)

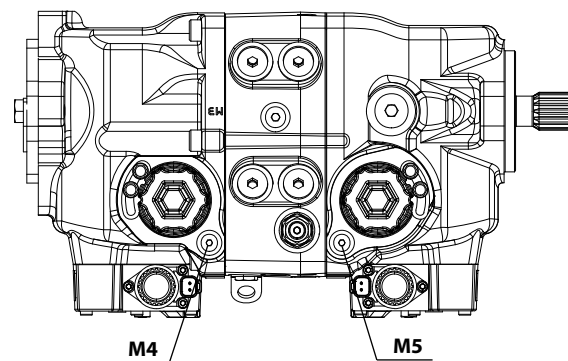
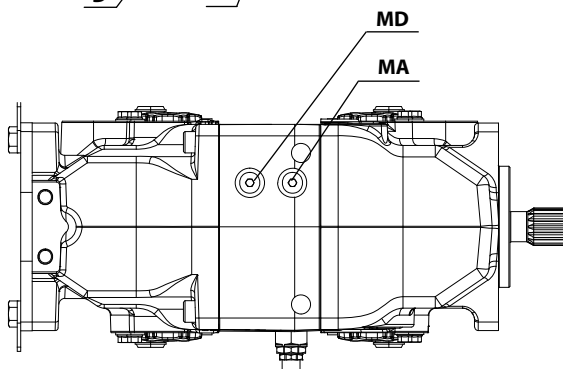
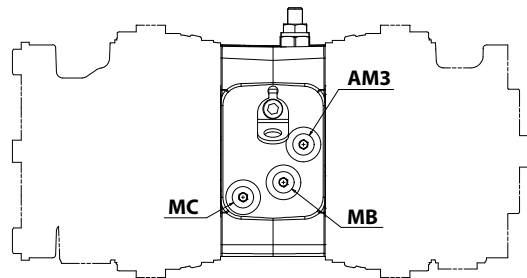
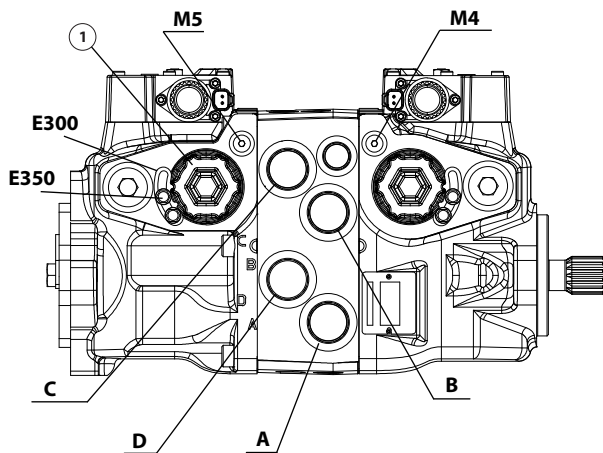

P109257

Legend: Ports per ISO 11926-1

A, B, C, D

MA, MB, MC, MD

M3, AM3

M4, M5

X7

System port: 1 ⁵/₁₆-12

System gauge port: ⁹/₁₆-18

Charge port: ⁹/₁₆-18

Servo gauge port: ⁷/₁₆-20

Brake gauge port: ⁹/₁₆-18

Adjustments

Servo and system pressure gauge port locations (060/068)

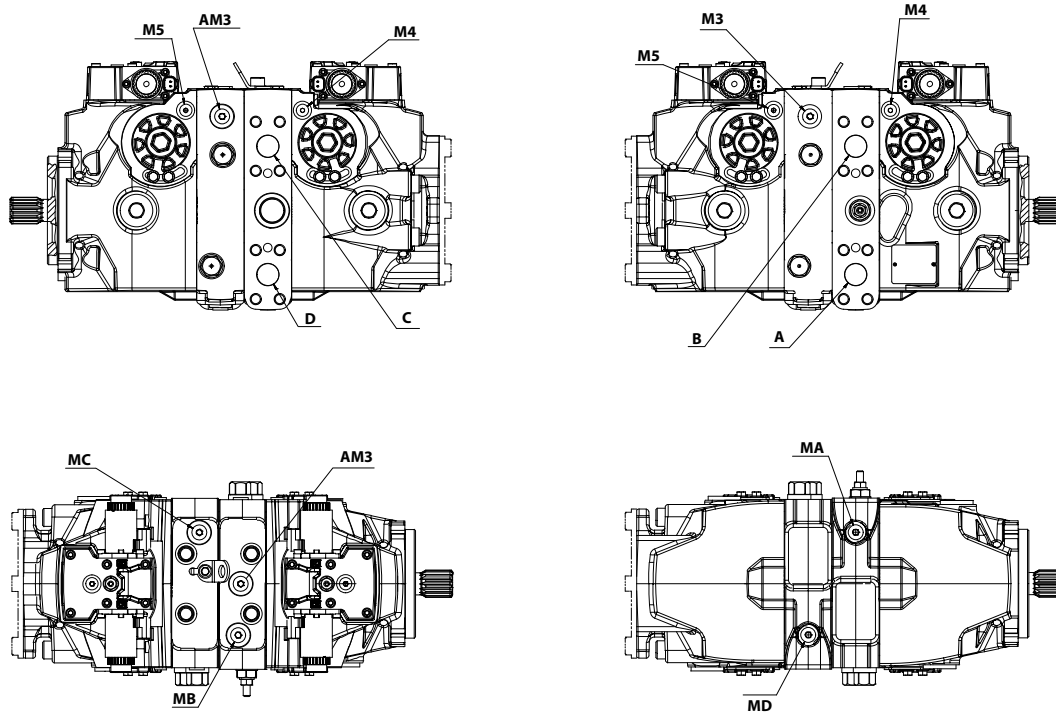

P109555

Legend: Ports per ISO 11926-1

A, B, C, D

System port: Split flange M12 x 1.5

MA, MB, MC, MD

System gauge port: $\frac{9}{16}$ -18

M3, AM3

Charge port: $\frac{9}{16}$ -18

M4, M5

Servo gauge port: $\frac{7}{16}$ -20

X7

Brake gauge port: $\frac{3}{4}$ -16

E300

Servo cylinder clamp

E350

Servo cylinder clamp bolt

1. Run prime mover at 1800 min^{-1} (rpm).
2. If using a PWM signal, ensure the signal is off.
3. Check the servo pressure gauges, ensure the differential between M4 and M5 is less than 2.5 bar [36 psi].
4. Using a 3/4 in deep socket, unthread both servo cylinders 2-3 turns.

This step ensures the servo cylinders have no contact with the servo piston.

5. Stroke the pump by turning the control eccentric screw (or supplying current to solenoid C1) until the servo pressure at port M4 is 1 to 2 bar [14– 29 psi] greater than at port M5 and the system pressure gauges indicate displacement.

Pressure should be greater at port MA for clockwise rotation, or MB for counterclockwise rotation. This also indicates the servo piston is in contact with the servo cylinder on side M5.

Adjustments

6. Maintain servo pressure differential between 1-2 bar [14-29 psi] during this step. Slowly thread the servo cylinder on the M5 side in until the system pressure differential starts to decrease. Continue turning the servo cylinder in until the system delta pressure results in no machine movement.

System delta pressure (ports MA to MB or MC to MD) between 3-4 bar typically does not cause machine movement. If service of a pump is not performed on the machine, validation of machine movement must be checked upon machine start up.

7. Repeat steps 1. to 5. but stroke the pump in the opposite direction by turning the eccentric screw in the opposite direction, or by supplying current to solenoid C2 to complete setting neutral.

Reverse gauge locations (M4 for M5, MB for MA etc.) from those stated above since the pump is now stroking the other direction.

8. Set neutral for the rear pump by repeating steps **1. to 6.** on the rear pump. Remember that the rear pump is a mirror image of the front pump and therefore the locations of the servo gauge ports (M4/M5) and the control solenoids (C1/C2) are opposite.
9. Remove all gauges and replace gauge port plugs.

You can find wrench sizes and plug torques in the [Plug Size and Torque Chart](#) on page 78.

Minor repair

Standard Procedures at Removing Pump

Before working on the pump, thoroughly clean the outside. If the pump has an auxiliary pump attached, remove both pumps as a single unit.

1. With the prime mover off, thoroughly clean all dirt and grime from the outside of the pump.
2. Tag, disconnect, and cap each hydraulic line connected to the pump.
3. As hydraulic lines are disconnected, plug each open port, to ensure that dirt and contamination do not get into the pump.

Be careful, do not damage solenoids and electrical connections when using straps or chains to support the pump.

4. Ensure the work surface and surrounding area are clean and free of contaminants such as dirt and grime.
5. Inspect the system for contamination.
6. Look at the hydraulic fluid for signs of system contamination, oil discoloration, foam in the oil, sludge, or metal particles.
7. Before replacing the pump, replace all filters and drain the hydraulic system.
8. Flush the system lines and fill the reservoir with the correct, filtered hydraulic fluid.
9. Fill the pump with clean, filtered hydraulic fluid.
10. Attach the pump to the prime mover and torque mounting screws according to the manufacturers recommendation.
11. Replace all hydraulic lines.
12. Ensure the charge inlet line is filled with fluid.

EDC/HDC Control Repair

EDC control module and solenoid removal/installation

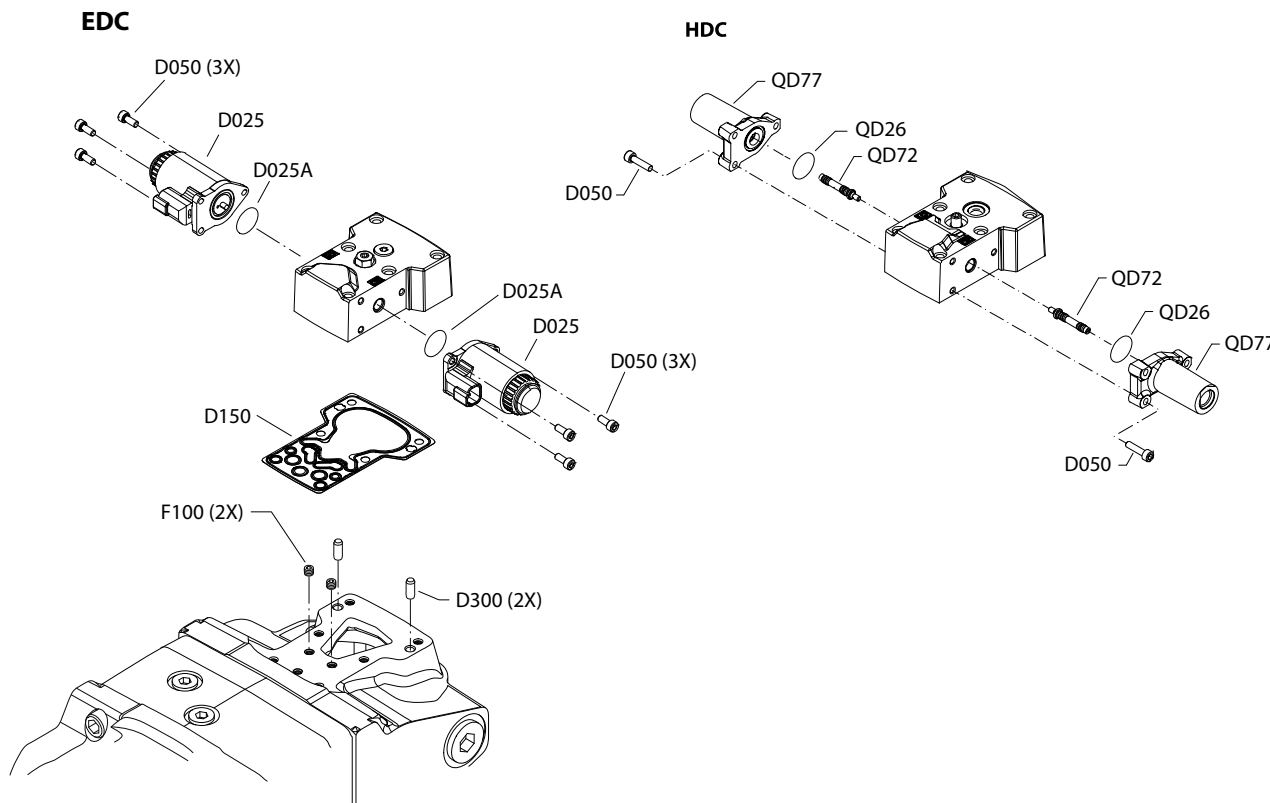

Minor repair

1. Using a 5 mm internal hex wrench, remove the six cap screws (D250)
2. Remove the control module and gasket (D150) and discard the gasket.
3. If necessary, remove orifices (F100) using a 3 mm internal hex wrench.

Tag and number the orifices for reinstallation.

4. If screen (D084) is clogged, use a hook to remove retaining ring (D098) and screen.
5. Remove and discard screen (D084).

EDC/HDC Control Installation

Inspect the machined surfaces on the control and top of the pump. If you find any nicks or scratches, replace the component.

Ensure you install dowel pins (D300) in housing before installing control.

1. Install a new gasket (D150).
2. If you removed screen (D084), install a new one with the mesh facing outward.

Remove plug on top of control to ensure the swashplate feedback pin is properly positioned in the center of the control module when installing control.

Proper screen orientation

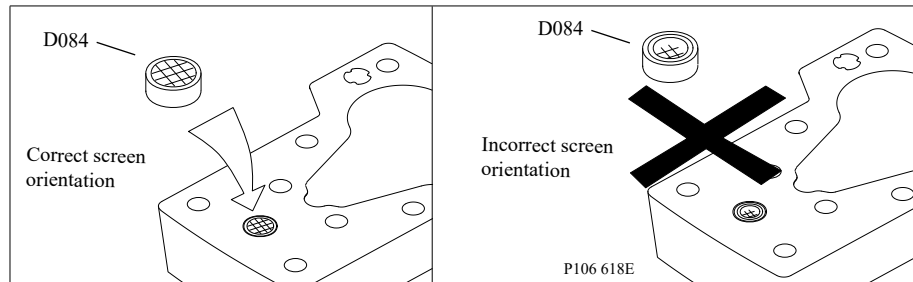

3. If previously removed, install orifices using a 3 mm internal hex wrench and torque to 2.5 N•m [1.8 lbf•ft].
4. Install the control module and six cap screws (D250).
5. Using a 5 mm internal hex wrench, torque the cap screws (D250) to 13.3 N•m [9.8 lbf•ft].

Torque sequence

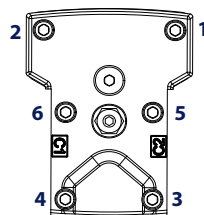

Minor repair**Control Solenoids Repair**

1. Disconnect electrical connection and remove the three cap screws (D050) using a 4 mm internal hex wrench.
2. Remove the solenoid (D025) and O-ring (D025A). Discard the O-ring.
3. If necessary, remove the coil using a 12 point 26 mm socket.

Inspect the machined surfaces on the control and top of the pump. If you find any nicks or scratches, replace the component.

4. Lubricate new O-ring (D025A) using petroleum jelly and install.
5. Install solenoid with three cap screws (D050) using a 4 mm internal hex wrench and torque screws to 8 N•m [6 lbf•ft].
6. Install coil using a 12 point 27 mm socket and torque coil nut to 5 N•m [3.7 lbf•ft].
7. Reconnect electrical connections and test the pump for proper operation.

Minor repair

MDC Control Repair

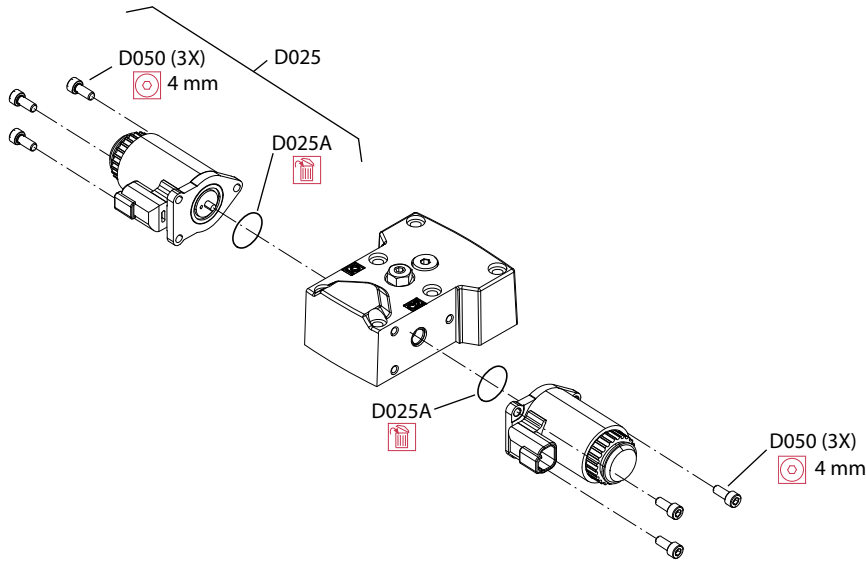

MDC Repair Legend:

- D80** – Solenoid
- D81** – O-ring
- D098** – Retaining ring
- D750** – Neutral start switch
- D751** – O-ring

Wrench size and torque

Item	Description	Wrench size	Torque
D065	O-ring plug	3/16 internal hex	12 N•m [9 lbf•ft]
D200	Feedback pin	13 mm deep well socket	22.5-27.5 N•m [16.6-20.3 lbf•ft]
D250	Cap screw	5 mm internal hex	13.3 N•m [9.8 lbf•ft]
D735	Plug	3/4 inch	30 N•m [22 lbf•ft]
F00A, F00B	Servo orifice	3 mm internal hex	2.5 N•m [1.8 lbf•ft]
F00P	Supply orifice		
F00T	Tank orifice		

1. Using a 5 mm internal hex wrench, remove the six cap screws (D250)
2. Remove the control module and gasket (D150) and discard the gasket.
3. If necessary, remove servo orifices (F00A, F00B), supply orifice (F00P), and tank orifices (F00T) using a 3 mm internal hex wrench.

Tag and number the orifices for reinstallation.

4. If screen (D084) is clogged, use a hook to remove retaining ring (D098) and screen.
5. Remove and discard screen (D084).
6. Before removing the control, note the position of the control lever for reassembly.

The functionality of the MDC control and the neutral position of the pump can be lost.
 Do not disassemble the MDC control.

Minor repair

MDC Control Assembly

Ensure you install dowel pins (D300) in housing before installing control.

The pump will lose control, causing a potentially hazardous situation.

If a feedback pin comes off during operation, ensure the feedback pin is properly torqued before continuing with reassembly.

1. Install a new gasket (D150).
2. If you removed screen (D084), install a new one with the mesh facing outward.
3. Install retaining ring (D098).

Proper screen orientation

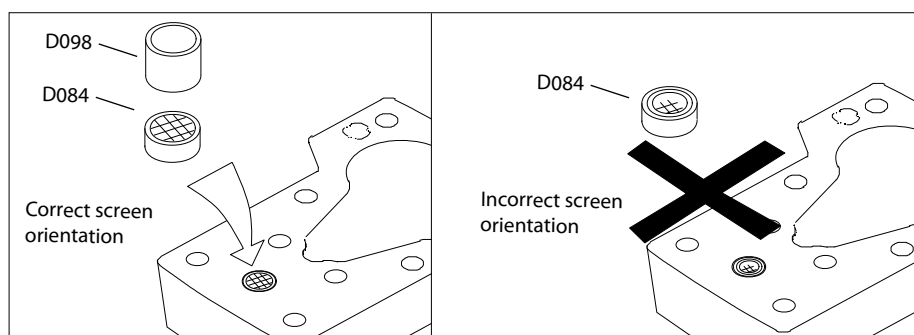

Remove plug on top of control to ensure the swashplate feedback pin is properly positioned in the center of the control module when installing control.

4. If previously removed, install orifices using a 3 mm internal hex wrench and torque to 2.5 N•m [1.8 lbf•ft].
5. Install the control module and six cap screws (D250).
6. Using a 5 mm internal hex wrench, torque the cap screws (D250) to 13.3 N•m [9.8 lbf•ft].

Torque sequence

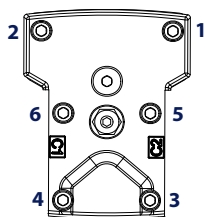

Minor repair

Angle sensor on EDC Repair

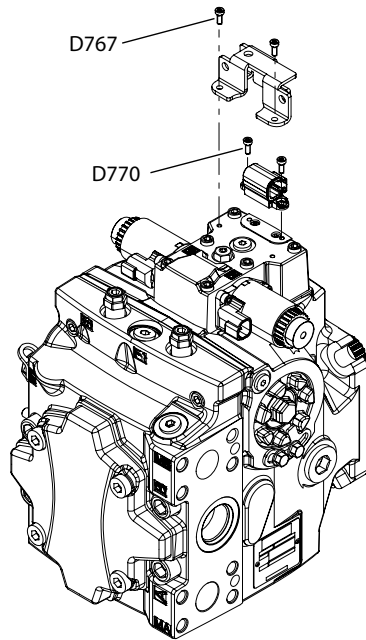

1. Clean the exterior of the pump to remove debris.
2. Remove protection cover screws (D767) using a 4 mm internal hex wrench.
3. Remove the protection cover from the control.
4. Discard the protection cover if it is damaged.
5. Remove sensor screws (D770) using a 4 mm internal hex wrench.
6. Remove and discard the sensor.
7. Position a new sensor on control housing.
8. Using a 4 mm internal hex wrench, fasten sensor to control housing with screws (D770). Torque screws to 1.85 N·m [1.36 lbf·ft].
9. Position protection cover on control housing over sensor.
10. Using a 4 mm internal hex wrench, fasten protection cover with screws (D767). Torque screws to 1.85 N·m [1.36 lbf·ft].

⚠ Warning

Calibration of sensor output in vehicle software is mandatory after sensor replacement because output signal can vary from one sensor to the other.

Minor repair

EDC with Angle Sensor Repair

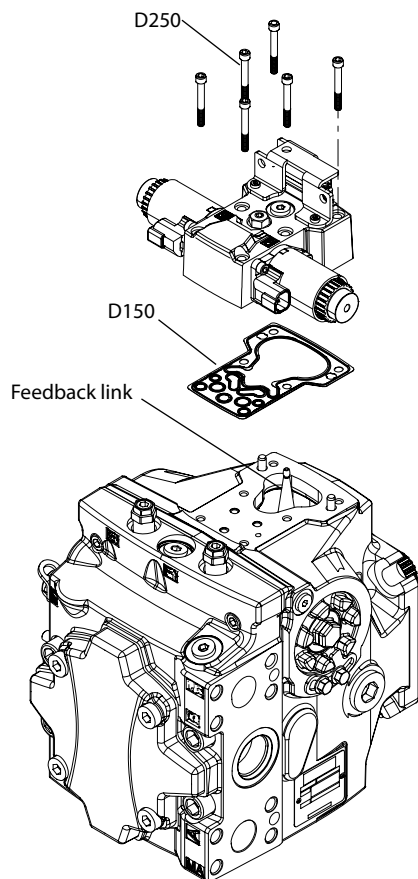

Dowel pins (D300) must remain in the housing.

1. Clean pump externally with clean solvent to remove debris.
2. Using a 5 mm internal hex wrench, remove the six cap screws (D250)
3. Remove the control module and gasket (D150) and discard the gasket.
4. Install a new gasket (D150).
5. Ensure assembly fixture is positioned over the linkage spring in EDC center.
6. Position the control on the pump housing and ensure that feedback pin on swashplate is positioned properly in control arm.

Minor repair

7. Pull assembly fixture out before installing control screws.

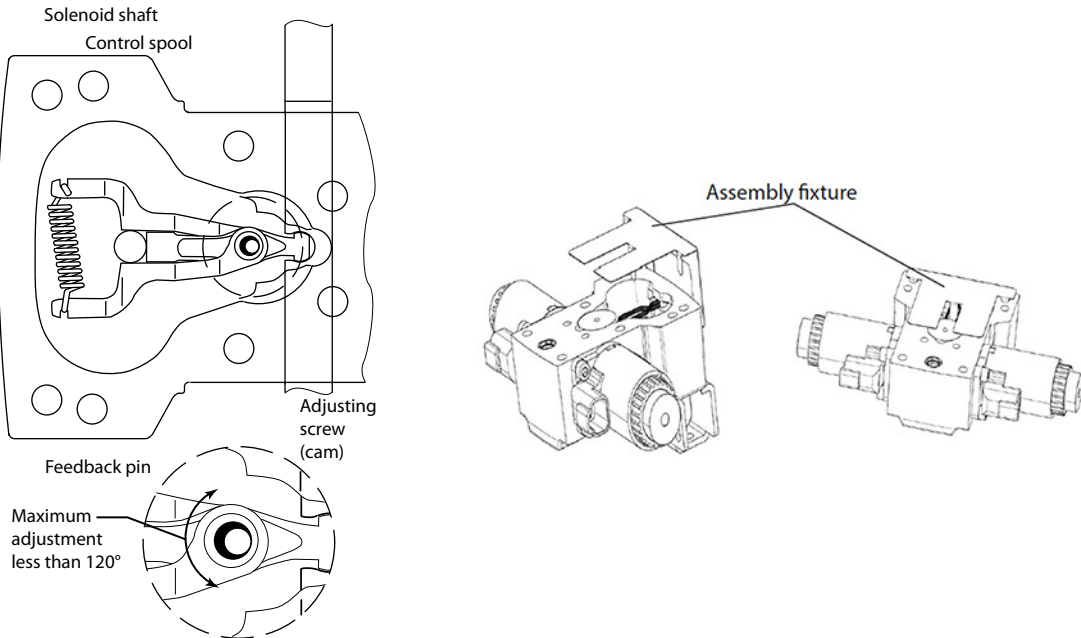

Remove plug (D065) and verify the swashplate feedback pin is properly positioned between control feedback arms.

8. Install the control module and six cap screws (D250).
9. Using a 5 mm internal hex wrench, fasten control to pump with screws (D250).
10. Torque screws to 13.3 N·m [9.8 lbf·ft] following torque sequence shown.

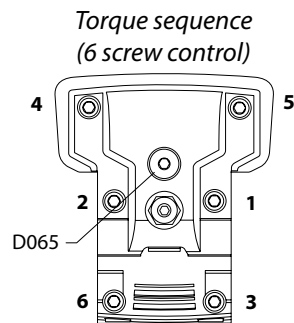

For proper neutral adjustment procedure, refer to *Control Neutral Adjustment* on page 51 topic.

Warning

Calibration of sensor output in vehicle software is mandatory after sensor replacement because output signal can vary from one sensor to the other.

Minor repair

Shaft, Seal and Bearing Repair

The input shaft, seal, and front bearing are serviceable without disassembling the entire pump. Orient the pump on the work surface so the shaft is pointing up.

Shaft assembly (45/53 shown)

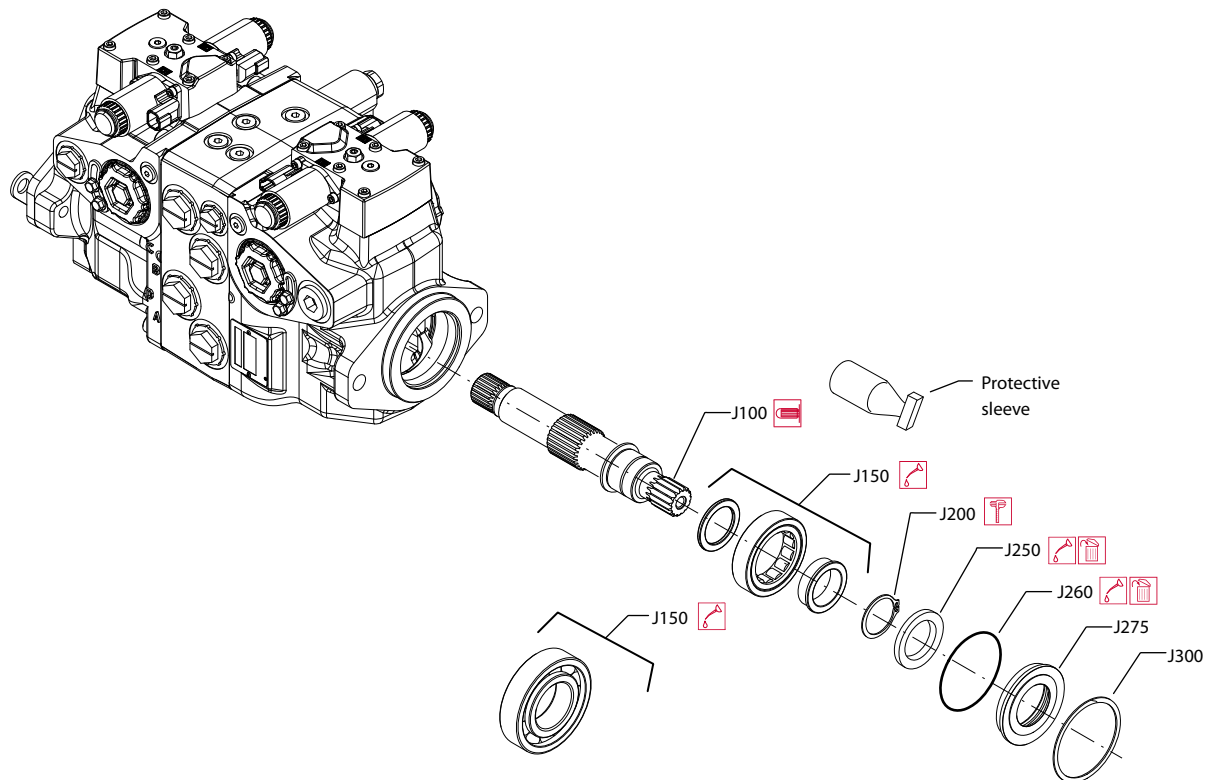

1. Remove the retaining ring (J300) from the housing to release the shaft/seal/bearing subassembly.
2. Pry on the lip of the seal carrier (J275) to remove it from the pump.
3. Remove the seal carrier.
4. Remove and discard O-ring (J260).
5. Press the seal (J250) out of the carrier and discard.
6. Pull the shaft (J100) with bearing (J150) out of the pump.

If necessary, tap lightly on the shaft to dislodge it from the cylinder block.

! Caution

Do not damage the housing bore, shaft or bearing when removing the shaft and bearing.

7. Remove the retaining ring (J200) using retaining ring pliers. Press the bearing off the shaft.
8. Inspect the shaft journals for wear, scratching, and pits.
9. Check the splines for fretting; replace if damaged.
10. Rotate the bearing, if it does not rotate smoothly, replace it.

Minor repair

Shaft, Seal and Bearing Installation

1. Inspect the shaft journals for wear, scratching, and pits.
2. Check the splines for fretting; replace if damaged.
3. Rotate the bearing, if it does not rotate smoothly, replace it.
4. Press the bearing (J150) onto the shaft (J100) and replace the retaining ring (J200).
5. Ensure the retaining ring diameter is less than 38.84 mm [1.53 in] when installed on the shaft.
6. Install the shaft/bearing assembly into the pump.
7. Lubricate and install a new O-ring (J260) onto seal carrier (J275).
8. Press a new seal (J250) into the seal carrier.

Press the seal until it is flush within +0.12 mm [0.005 in] or -0.72 mm [0.003 in] of the inside lip of the carrier:

Positioning seal in seal carrier

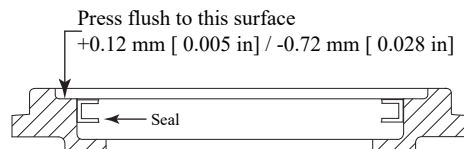

P106 498E

9. Cover the shaft with a protective sleeve while installing the seal carrier.
10. Hand press the seal carrier into the housing.
11. Ensure the seal carrier clears the retaining ring groove in the housing.
12. Remove the protective sleeve.
13. Install the retaining ring (J300).
14. Ensure the inside diameter of the retaining ring is greater than 68 mm [2.68 in] after installation.

Minor repair

Charge Pump Repair (045/053 only)

If an auxiliary pump is attached, remove auxiliary pump and coupling before servicing charge pump.
Position pump with front shaft pointing downward. Attach securely to a proper work stand.

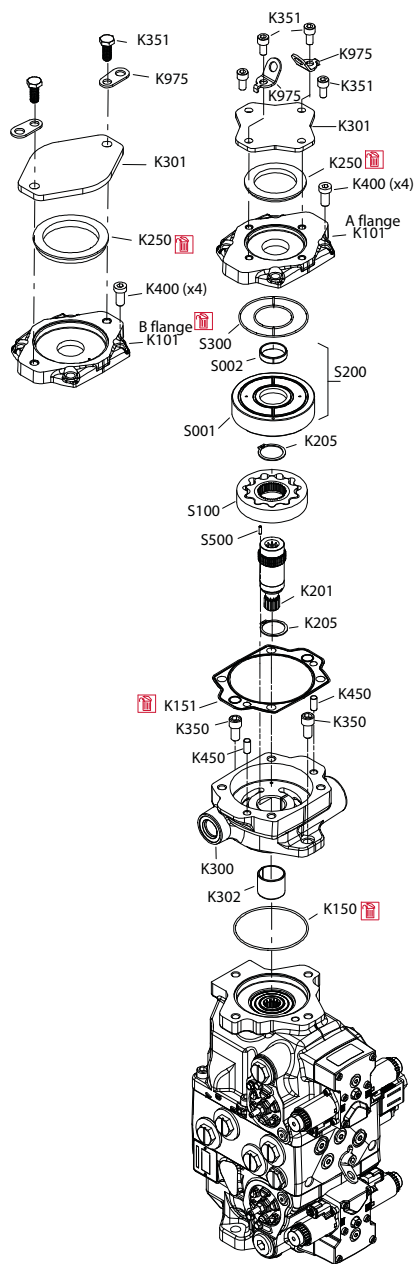

Wrench size and torque

Item	K350	K351 (A flange)	K351 (B flange)	K400
Wrench size	10 mm internal hex	8 mm internal hex	18 mm	10 mm internal hex
Torque	76 N·m [56 lbf·ft]	64 N·m [47 lbf·ft]	76 N·m [56 lbf·ft]	92 N·m [68 lbf·ft]

1. Remove screws (K351), and hangers (K975).
2. Remove running cover (K301).
3. Remove and discard seal ring (K250).

Minor repair

4. Using a 10 mm internal hex, remove screws (K400), and cover (K101).
5. Remove and discard seal (S300).
6. Remove geroter cover (S200).

Note the position of the alignment pin (S500) in the housing. The alignment pin position is different for clockwise or counterclockwise rotation.

7. Remove and disassemble charge pump assembly.
Charge pump components: shaft (K201), pin (S500), geroter (S100), two clips (K205).
8. Remove and discard gasket (K151). Remove alignment pins (K450).
9. If it is necessary to remove housing (K300), use a 10 mm internal hex to remove screws (K350).
10. Remove housing (K300).
11. Remove and discard seal (K150).
12. Inspect carefully all machined surfaces, geroter and cover, shaft, journal bearings in aux. pad and housing.
If you find any nicks or scratches, any sign of worn or damage, replace the component (geroter kit or shaft). Use a suitable press to remove and replace the journal bearings, see below:

Replacing the journal bearings

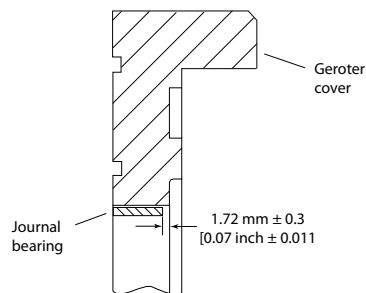

P107 999E

Charge Pump Installation

1. Lubricate and install new seal (K150).
2. Install housing (K300). Install screws (K350). Using a 10 mm internal hex, torque screws per listing in table.
3. Install alignment pins (K450). Install new gasket (K151).
4. Lubricate and reassemble the charge pump assembly, [shaft (K201), pin (S500), geroter (S100), two clips (K205)].

Install the alignment pin (S500) in its original position. The alignment pin position is different for clockwise or counterclockwise rotation.

5. Install the charge pump assembly into the housing.
6. Install the geroter cover (S200).
7. Lubricate and install the seal (S300).
8. Install the aux pad (K101).
9. Using a 10 mm internal hex, install screws (K400).
10. Lubricate and install seal (K250). Install running cover (K301).
11. Install screws (K351) and brackets (K975).
Torque screws per listing in the table, see [Charge Pump Repair \(045/053 only\)](#) on page 67.

Minor repair

Charge Check and HPRV Repair (045/053)

The high pressure relief and charge check valve assemblies may be removed for cleaning and replacement of the O-rings. These valves are factory set and are not field adjustable. Refer to the pump model code for the factory setting when ordering replacements.

Charge check / HPRV

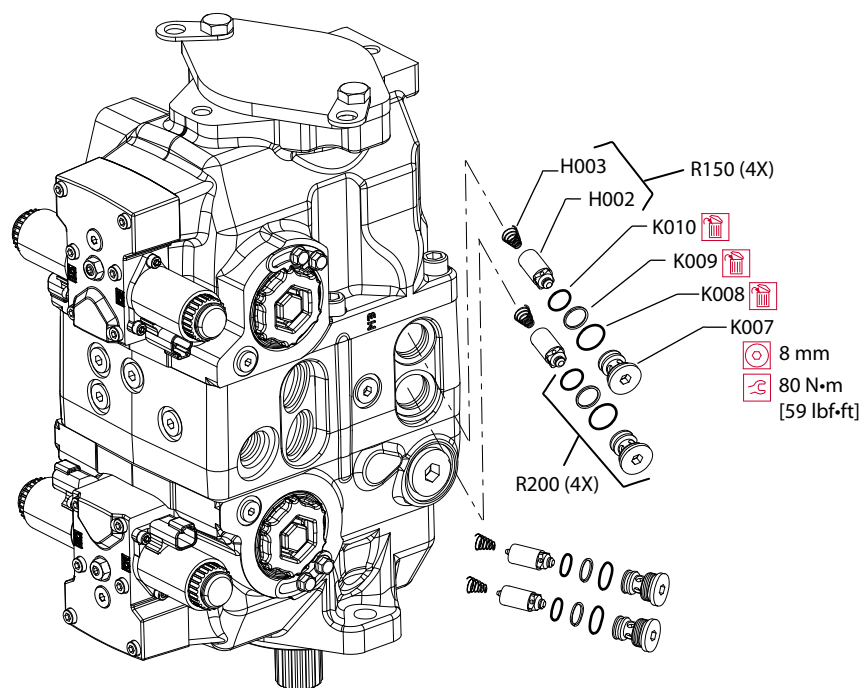

Rear pump location shown. There are four valve assemblies in total.

1. Using an 8 mm internal hex wrench, remove the valve seat plugs (K007).
2. Carefully lift the valve (H002) and spring (H003) assemblies from the center section using a magnet.
3. Inspect the valves and mating seats in the valve seat plugs (K007) for damage or foreign material.
4. Lubricate and install new O-rings (K008, K010) and backup ring (K009) on valve seat plug (K007).
5. Verify that the conical springs (H003) are properly retained on the check relief valves (H002).
6. Install the valve assemblies into the center section.
Ensure each valve assembly moves freely in its bore.
7. Install the valve seat plugs into the center section and torque to 80 N·m [59 lbf·ft].
8. Operate the vehicle/machine through its full range of control to ensure proper operation. Check for leaks.

Minor repair

HPRV Port Relationship

The illustration below illustrates the relationship between the HPRVs and the ports controlled by those valves.

HPRV port relationship

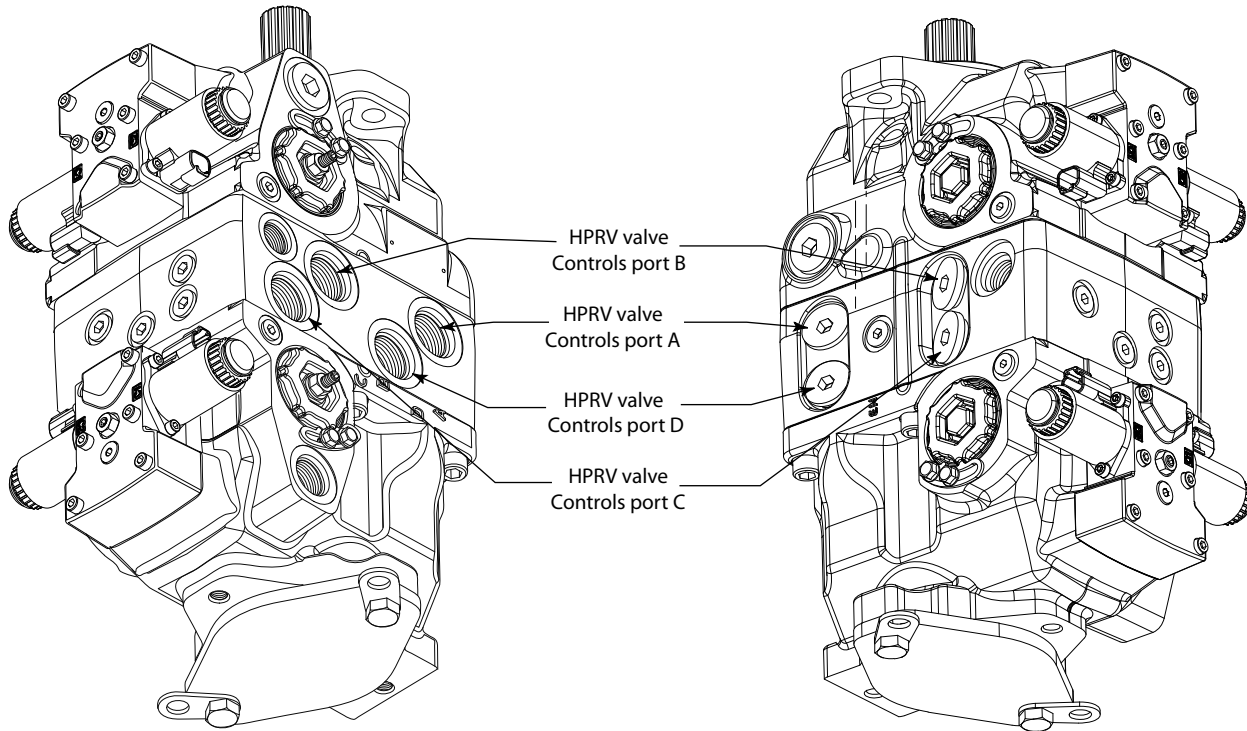

Minor repair

HPRV (60/68)

Pressure Limiter Screens

⚠ Warning

Pumps with only HPRV valves no longer contain pressure limiter (PL) screens and retainer. To convert the pumps to use pressure limiter valves, please contact your Danfoss Service Partner. Pumps that have PL valves without PL screens and retainers are at high risk of contamination and product malfunction.

H1P Base Models with pressure settings option B include PL screens and retainers.

HPRV Repair (060/068)

The high pressure relief and charge check valve assemblies may be removed for cleaning and replacement of the O-rings. These valves are factory set and are not field adjustable. Refer to the pump model code for the factory setting when ordering replacements.

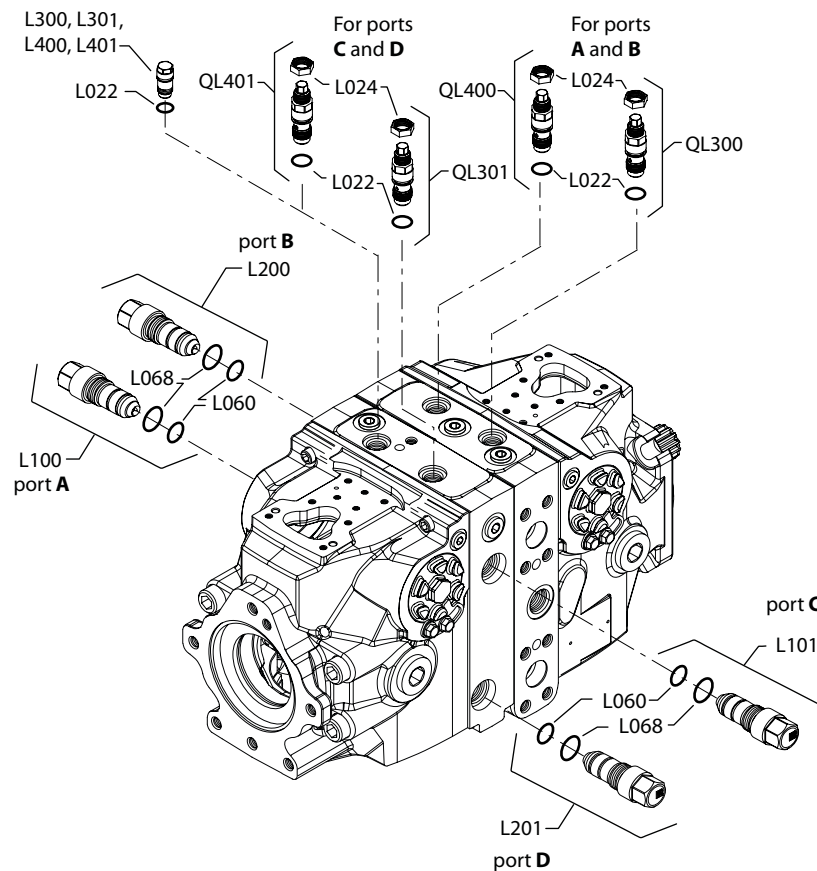

P109251

Item	Description	Wrench size	Torque
L300, L301, L400, L401	Pressure limiter plug assembly	14 mm	30 N•m [22 lbf•ft]
QL300, QL301, QL400, QL401	Pressure limiter valve assembly	17 mm	30 N•m [22 lbf•ft]
L100, L101, L200, L201	High Pressure Relief Valve	22 mm	70 N•m [51.6 lbf•ft]

Minor repair

1. Mark the location of each valve prior to removal.
2. Using a 22 mm wrench remove the HPRVs.
3. Remove and discard the O-rings (L060) and backup rings (L068).
4. Clean oil off the sealing surfaces and inspect the sealing surfaces for nicks or scratches. Check the valves for damage. Replace any damaged components.
5. Lubricate and install new backup rings (L068) and O-rings (L060).
6. Install HPRV and pressure limiter valves in their original locations.
7. Operate the vehicle/machine through its full range of control to ensure proper operation. Check for leaks.

Minor repair

Charge Pressure Relief Valve Repair

Replace the charge pressure relief valve (V10-1 or V10-2) as a complete unit. Do not attempt to repair the internal components of the valve.

See [Charge Pressure Relief Valve Adjustment](#) on page 41 for adjustment instructions.

Charge pressure relief valve

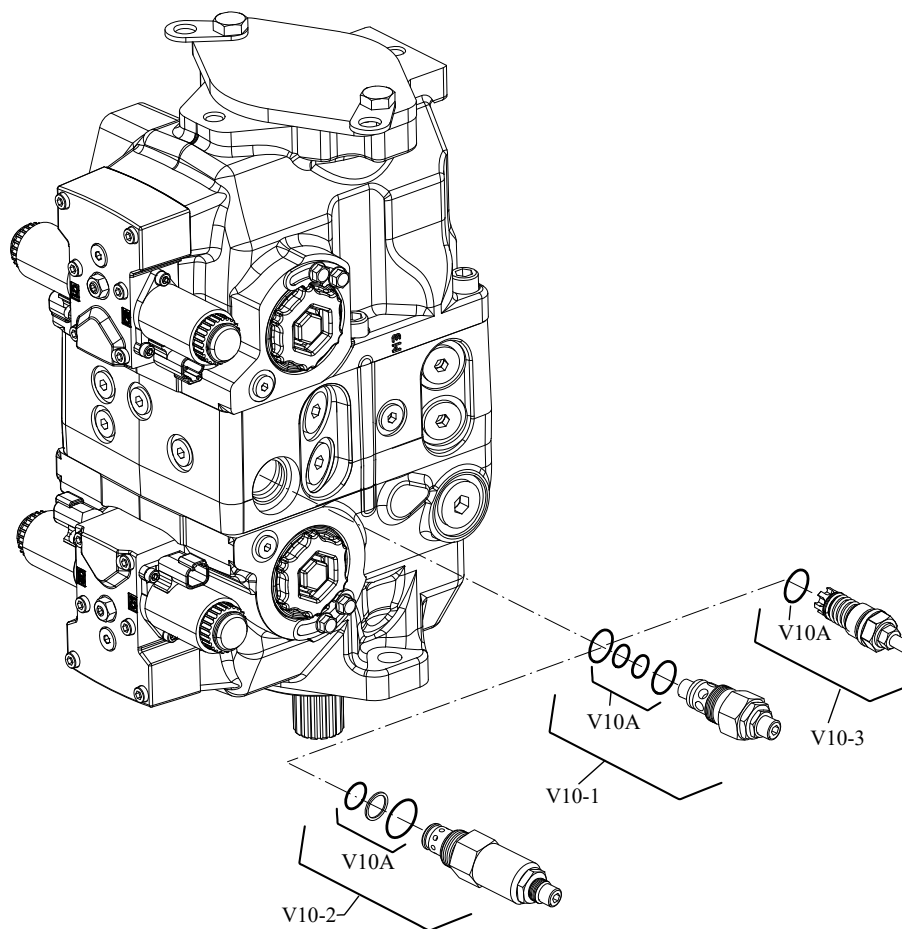

P109568

Legend:

V10-1, V10-3 wrench size: 27 mm, torque to 52 N•m [38 lbf•ft]

V10-2 wrench size: 1 inch, torque to 52 N•m [38 lbf•ft]

1. Using a 27 mm (V10-1) or a 1 in (V10-2) wrench, remove the charge pressure relief valve.
2. Discard the O-rings (V10A).
3. Inspect the sealing surfaces of the pump and charge pressure relief valve for nicks or scratches.
4. Replace components as necessary.
5. Lubricate and install new O-rings (V10A).
6. Install the charge pressure relief valve (V10). Torque to 52 N•m [38 lbf•ft].
7. Operate vehicle/machine through full range of controls to ensure proper operation.

Minor repair

Control Cut-off Valve / Brake Valve Repair

Replace the control cut-off valve as a complete unit. Do not attempt to repair the internal components of the valve.

Control cutoff valve (045/053)

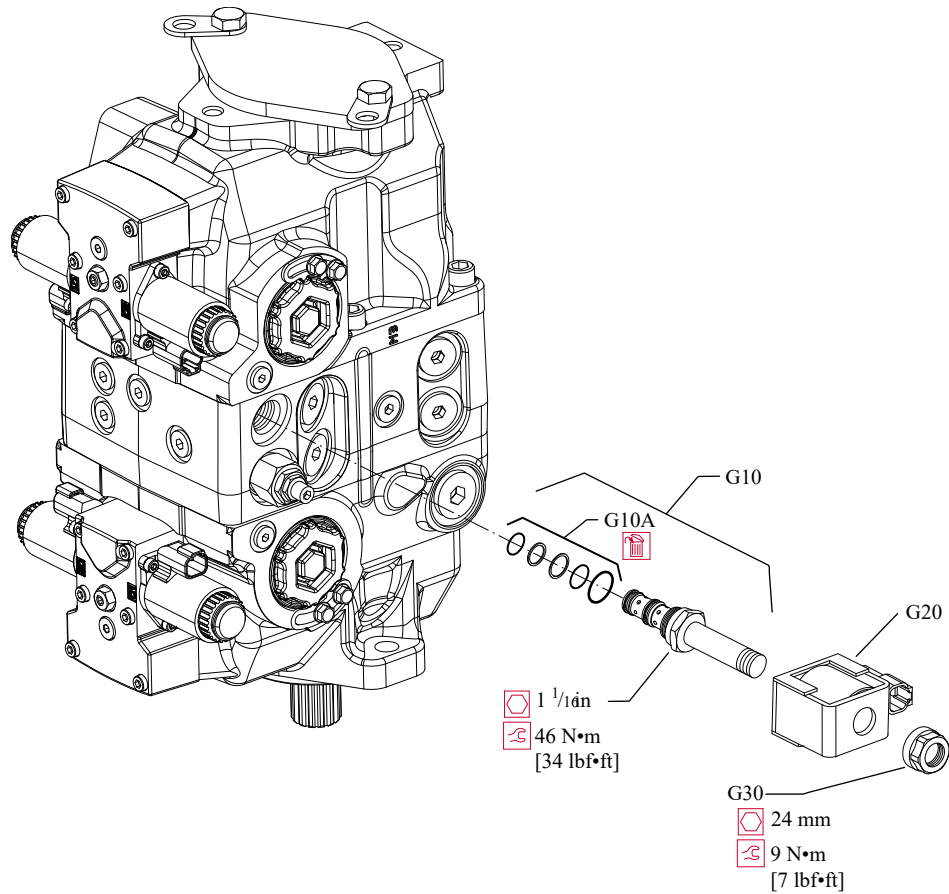

E101 401E

Minor repair

Control cutoff valve (060/068)

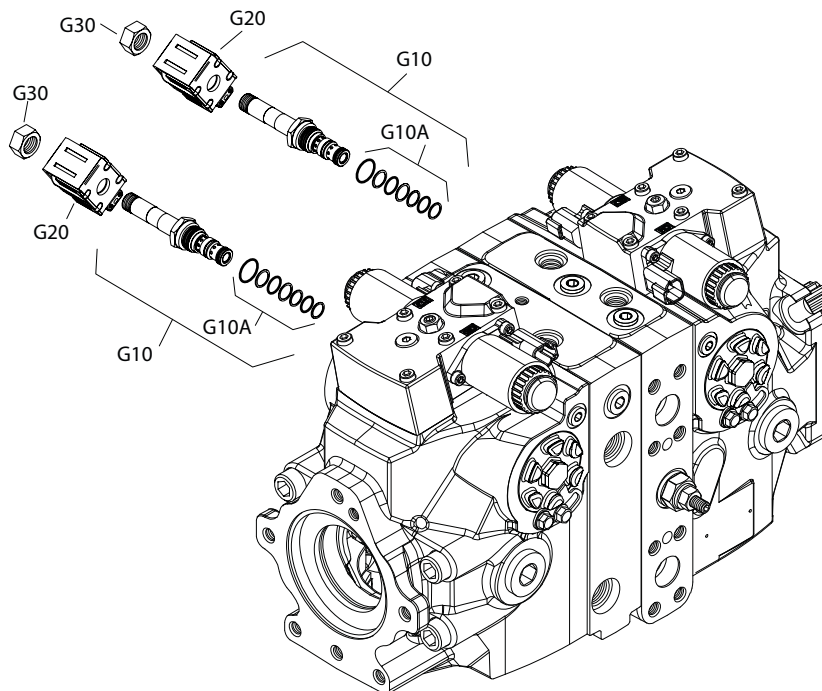

1. Disconnect the coil from the vehicle/machine wire harness.
2. Using a 24 mm hex wrench, remove the control cut-off valve coil nut (G30).
3. Remove the coil (G20).
4. Use a 1 1/16 in hex wrench to remove the control cut-off valve (G10).
5. Remove and discard the O-rings and backup rings (G10A).
6. Inspect the sealing surfaces of the pump and control valve for nicks or scratches.
7. Replace components as necessary.
8. Lubricate and install new O-rings (G10A) onto the valve.
9. Install the control valve (G10). Torque to 46 N•m [34 lbf•ft].
10. Slide the coil (G20) onto the valve.
11. Install the coil nut (G30). Torque to 9 N•m [7 lbf•ft].

! Caution

Do not over torque.

12. Operate vehicle/machine through full range of controls to ensure proper operation.

Torque Chart

Fasteners and Plugs

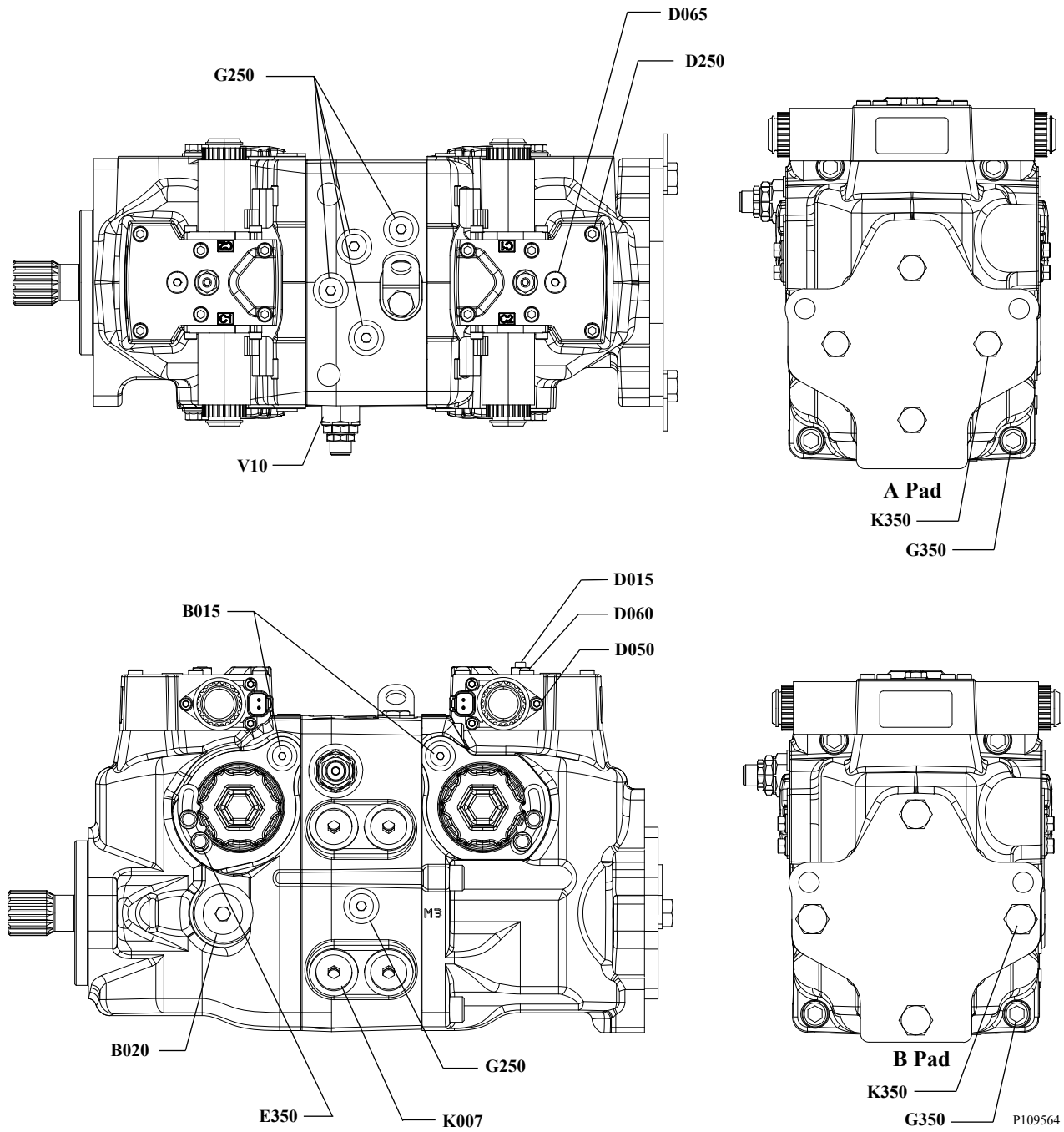

Torque Chart

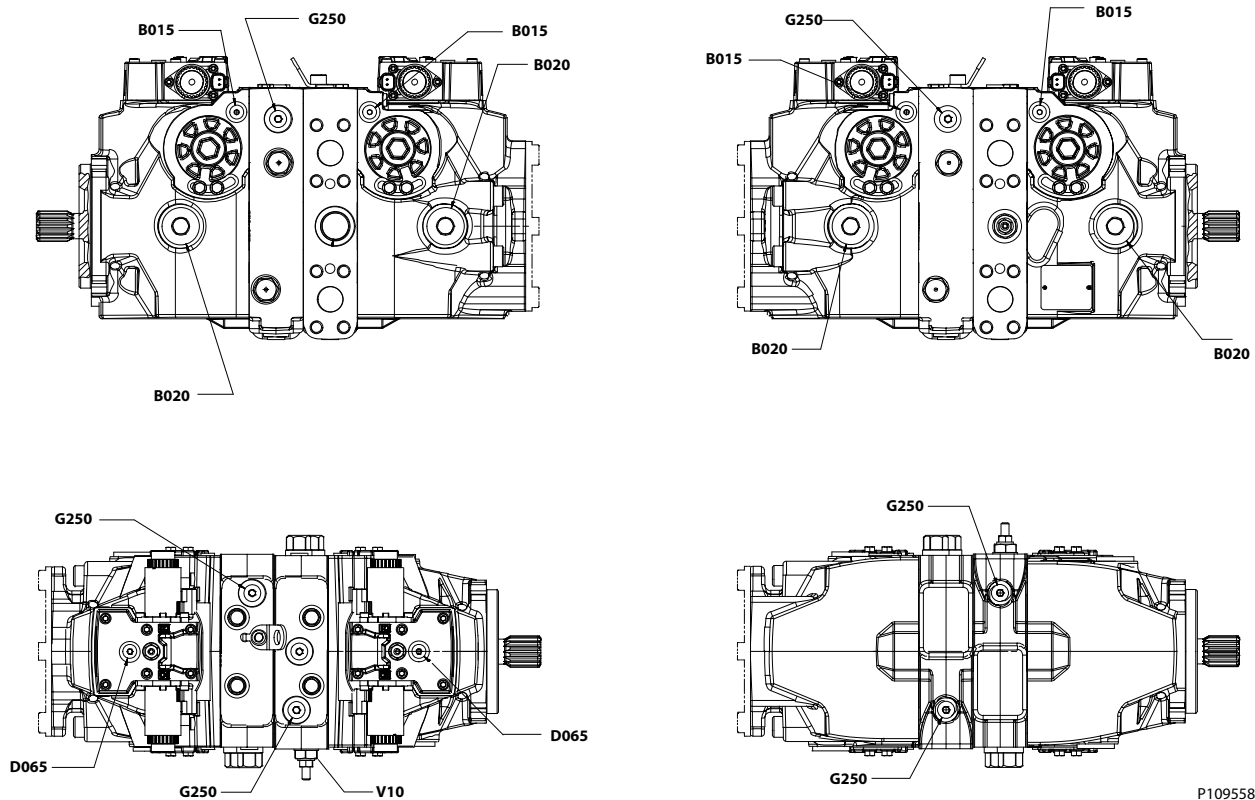

P109558

Fastener Size and Torque Chart

Item	Fastener	Wrench size	Torque
D015	Neutral adjust screw	4 mm internal hex	NA
D050	Control coil mounting screw	4 mm internal hex	8 N•m [5.9 lbf•ft]
D060	Neutral adjust locking nut	13 mm hex	10 N•m [7 lbf•ft]
D200	Swash plate feedback pin (not shown)	13 mm hex	25 N•m [18.4 lbf•ft]
D250	Electric control mounting screw	5 mm internal hex	13 N•m [9.5 lbf•ft]
E350	Servo cylinder locking screw	10 mm hex	14.5 N•m [11 lbf•ft]
G10	Control cut-off valve	1 1/16 in hex	45 N•m [33 lbf•ft]
G10B	Control cut-off valve coil nut	24 mm hex	10 N•m [7.5 lbf•ft]
K007	Charge check / HPRV	8 mm internal hex	80 N•m [60 lbf•ft]
K350	A pad cover mounting screw	17 mm hex	64 N•m [47 lbf•ft]
	B pad cover mounting screw	18 mm hex	76 N•m [56 lbf•ft]
L010	Pressure limiter adjust screw	8 mm internal hex	NA
L300/L400/L101/L201	Pressure limiter cartridge	14 mm hex	30 N•m [22 lbf•ft]
L024	Pressure limiter locking nut	14 mm hex	20 N•m [15 lbf•ft]
L100/L200/L101/L201	High pressure relief valve	22 mm hex	70 N•m [52 lbf•ft]
V10-1 V10-2 V10-3	Charge relief valve	27 mm hex	52 N•m [38 lbf•ft]

Torque Chart

Item	Fastener	Wrench size	Torque
V020	Charge pressure adjusting screw	6 mm internal hex	NA
V022	Charge pressure locking nut	19 mm hex	40 N•m [30 lbf•ft]

Plug Size and Torque Chart

Item	O-ring plug	Wrench size	Torque
B015	7/16 - 20	3/16 internal hex	20 N•m [15 lbf•ft]
B020 (45/53)	1-1/16 - 12	9/16 internal hex	48 N•m [35 lbf•ft]
B020 (60/68)	1-3/8 - 12	5/8 internal hex	148 N•m [109 lbf•ft]
D065	7/16 - 20	3/16 internal hex	12 N•m [9 lbf•ft]
G250	9/16 - 18	1/4 internal hex (hardened plug)	45 N•m [33 lbf•ft]

Products we offer:

- Cylinders
- Electric converters, machines, and systems
- Electronic controls, HMI, and IoT
- Hoses and fittings
- Hydraulic power units and packaged systems
- Hydraulic valves
- Industrial clutches and brakes
- Motors
- PLUS+1® software
- Pumps
- Steering
- Transmissions

Danfoss Power Solutions designs and manufactures a complete range of engineered components and systems. From hydraulics and electrification to fluid conveyance, electronic controls, and software, our solutions are engineered with an uncompromising focus on quality, reliability, and safety.

Our innovative products makes increased productivity and reduced emissions a possibility, but it's our people who turn those possibilities into reality. Leveraging our unsurpassed application know-how, we partner with customers around the world to solve their greatest machine challenges. Our aspiration is to help our customers achieve their vision — and to earn our place as their preferred and trusted partner.

Go to www.danfoss.com or scan the QR code for further product information.

**Hydro-Gear**

www.hydro-gear.com

Daikin-Sauer-Danfoss

www.daikin-sauer-danfoss.com

**Danfoss
Power Solutions (US) Company**
2800 East 13th Street
Ames, IA 50010, USA
Phone: +1 515 239 6000

**Danfoss
Power Solutions GmbH & Co. OHG**
Krokamp 35
D-24539 Neumünster, Germany
Phone: +49 4321 871 0

**Danfoss
Power Solutions ApS**
Nordborgvej 81
DK-6430 Nordborg, Denmark
Phone: +45 7488 2222

**Danfoss
Power Solutions Trading
(Shanghai) Co., Ltd.**
Building #22, No. 1000 Jin Hai Rd
Jin Qiao, Pudong New District
Shanghai, China 201206
Phone: +86 21 2080 6201

Danfoss can accept no responsibility for possible errors in catalogues, brochures and other printed material. Danfoss reserves the right to alter its products without notice. This also applies to products already on order provided that such alterations can be made without subsequent changes being necessary in specifications already agreed. All trademarks in this material are property of the respective companies. Danfoss and the Danfoss logotype are trademarks of Danfoss A/S. All rights reserved.