

Data Sheet

Strainer FIA-140B

140 bar (2030 psi) series

The new 140 bar manual valve range for Industrial CO₂ Trans-critical Systems



The new 140 bar manual valve range for Industrial CO₂ Trans-critical Systems is based on the successful modular Standard SVL platform. The same flexibility, simplicity and efficiency are features offered in this new series.

The valves are available as parts program.

- From DN 50 (2") to 150 (6")
- In angle or straightway
- With DIN or ANSI butt-weld connections and DIN or ASME hard soldering (brazing) connections up to 64 mm or 2 1/8"

Features

- Applicable: R744 (CO₂) Sub and Trans critical
 - Each valve housing is available with several different connection types and sizes
 - Possible to convert SVA-140B strainers to other products in the Flexline™ SVL family (e.g. strainer) just by replacing the complete top part
- Max. working pressure: 140 bar (2030 psi)
- Temperature range -40 °C to +150 °C (-40 °F to +302 °F)
- Available in angle and straightway versions
- Each valve type is clearly marked with type, size and performance range
- Filter net of stainless steel mounted direct without extra gaskets means easy servicing
- Two types of strainer inserts are available:
 - A plain insert of stainless steel
 - A pleated insert with extra large surface, which ensures long intervals between cleaning and low pressure drop
- FIA-140B 50-100 (2 - 4 in.): A large capacity filter bag can be inserted for cleaning plant during commissioning
- FIA-140B 80-100 (3 - 4 in.) can be equipped with a magnetic insert for detention of iron particles and other magnetic particles
- Housing and bonnet material is low temperature steel according to requirements of the Pressure Equipment Directive and other international classification authorities
- Equipped with bolts in low temp steel with high tensile strength
- Classification: UL, CRN etc. To get an updated list of certifications on the products please contact your local Danfoss Sales Company

Media

Refrigerants

Applicable to R744 (CO₂).

New refrigerants

Danfoss products are continually evaluated for use with new refrigerants depending on market requirements.

When a refrigerant is approved for use by Danfoss, it is added to the relevant portfolio, and the R number of the refrigerant (e.g. R513A) will be added to the technical data of the code number. Therefore, products for specific refrigerants are best checked at store.danfoss.com/en/, or by contacting your local Danfoss representative.

Product specification

Design

Housing

Made of special, cold resistant steel

Strainer Insert

A filter grid and filter net of stainless steel ensure long element life. The filter net offer a very high degree of cleanability.

Pressure and temperature data

Table 1: Temperature and pressure

Description	Values
Temperature range	-40 °C / +150 °C (-40 °F / +302 °F)
Max. working pressure	140 bar (2030 psi)

Installation

The strainer is designed to resist high internal pressures. However, the piping system in general should be designed to avoid liquid traps and reduce the risk of hydraulic pressure caused by thermal expansion. Install the strainer with the cover in downward position.

For further information refer to installation instructions for [FIA-140B](#).

Figure 1: Example of Marking Ring FIA-140B

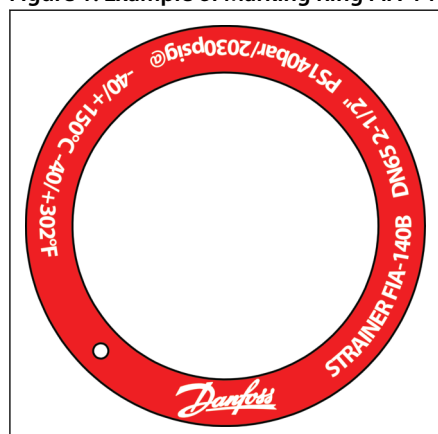

Selection of strainer size

The mesh aperture size of the strainer must satisfy the requirements stated by the suppliers of the equipment to be protected.

The following recommendations of aperture size apply in general to refrigeration installations:

Table 2: All lines

First start up: (Use strainer element with removable insert for FIA DN15-40 or separate filter bag for FIA DN 50-150. 50µ insert should normally be removed after the first 24 hours of operation)	50µ
---	-----

Table 3: Liquid Lines

Ahead of pumps:	500µ
After pumps:	150µ / 250µ

Table 4: Protection of automatic regulation equipment

Generally	150µ / 250µ
Sensitive equipment, e.g. suction regulators with low temperature	250µ

Strainer FIA-140B 140 bar (2030 psi) series

Table 5: Suction Lines

Ahead of screw compressor	250μ
Ahead of piston compressor	150μ

NOTE:

Mesh is the number of threads per inch. μ (microns) is the distance between two threads (1μ = 1 /1000 mm).

Table 6: Flow coefficient (DIN/ANSI)

Connection size (DN)	μ	mesh	wire	wire	free space	screen area				
			mm	in.	%	Plain elements		Pleated elements		
						cm ²	in ²	cm ²	in ²	
FIA										
15-20 (½"-¾")	50	100	0.25	0.01	35			45	7	
25-40 (1"-1½")	50	100	0.25	0.01	35			160	25	
50 (2")	50	100	0.25	0.01	35			200	31.2	
	150	100	0.1	0.004	36	87	13.5	200	31.2	
	250	72	0.1	0.004	51	87	13.5	200	31.2	
	500	38	0.16	0.006	57.6	87	13.5	200	31.2	
65 (2½")	50	100	0.25	0.01				305	47.6	
	150	100	0.1	0.004	36	127	19.7	305	47.6	
	250	72	0.1	0.004	51	127	19.7	305	47.6	
	500	38	0.16	0.006	57.6	127	19.7	305	47.6	
80 (3")	50	100	0.25	0.01				450	70.2	
	150	100	0.1	0.004	36	205	31.8	450	70.2	
	250	72	0.1	0.004	51	205	31.8	450	70.2	
	500	38	0.16	0.006	57.6	205	31.8	450	70.2	
100 (4")	50	100	0.25	0.01				790	123.2	
	150	100	0.1	0.004	36	370	57.4	790	123.2	
	250	72	0.1	0.004	51	370	57.4	790	123.2	
	500	38	0.16	0.006	57.6	370	57.4	790	123.2	
125 (5")	50	100	0.25	0.01				1105	172.4	
	150	100	0.1	0.004	36	510	79.1	1105	172.4	
	250	72	0.1	0.004	51	510	79.1	1105	172.4	
	500	38	0.16	0.006	57.6	510	79.1	1105	172.4	
150 (6")	50	100	0.25	0.01				1600	249.6	
	150	100	0.1	0.004	36	726	112.5	1600	249.6	
	250	72	0.1	0.004	51	726	112.5	1600	249.6	
	500	38	0.16	0.006	57.6	726	112.5	1600	249.6	
200 (8")	50	100	0.25	0.01	35			2900	453.1	

Table 7: k_v values for FIA angle/straight - plain filter net/pleated filter net

DN	FIA angle - pleated filter net			FIA straight - pleated filter net		
	μ150	μ250	μ500	μ150	μ250	μ500
50	56.7	58.8	62.0	45.9	47.6	50.2
65	69.3	71.4	74.6	56.1	57.8	60.4
80	129.2	133.4	139.7	104.6	108.0	113.1
100	200.6	206.9	217.4	162.4	167.5	176.0
125	340.2	350.7	368.6	275.4	283.9	298.4
150	447.3	462.9	-	362.1	374.0	-

Connections

Available with the following connections:

- Butt-weld DIN (EN 10216-2)
- Butt-weld ANSI (B 36.10 Schedule 80)
- Brazing EN 1254-5, 54 and 64mm
- Brazing ASME B16.50, 2 1/8" and 2 5/8"

Strainer FIA-140B 140 bar (2030 psi) series

The DN 50 Straight valve is machined from a normal DN 65 Straight sized valve house, but with DN 50 connections. The different geometry explains why the K_v/C_v value of the DN 50 Straight exceptionally is higher than DN 50 Angular.

Figure 2: DIN

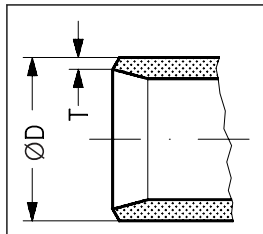

Table 8: Butt-weld DIN (EN 10216-2)

Size		ØD	T	ØD	T	k_v -angle	k_v -straight	C_v -angle	C_v -straight
mm	in.	mm	mm	in.	in.	m ³ /h	m ³ /h	US _{gal} /min	US _{gal} /min
50	2	60.3	5.0	2.37	0.20	67	79	77	91
65	2½	76.1	6.3	3	0.25	103	91	119	105
80	3	88.9	7.1	3.50	0.28	174	146	201	169
100	4	114.3	8.8	4.50	0.35	292	251	338	290
125	5	139.7	10	5.5	0.39	500	411	575	473
150	6	168.3	11	6.63	0.43	697	541	802	622

Figure 3: ANSI

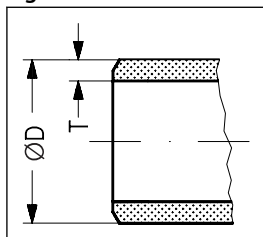

Table 9: Butt-weld ANSI (B 36.10 Schedule 80)

Size		ØD	T	ØD	T	k_v -angle	k_v -straight	C_v -angle	C_v -straight
mm	in.	mm	mm	in.	in.	m ³ /h	m ³ /h	US _{gal} /min	US _{gal} /min
50	2	60.3	5.6	2.37	0.22	67	79	77	91
65	2½	73.0	7.0	2.87	0.28	103	91	119	105
80	3	88.9	7.6	3.50	0.30	174	146	201	169
100	4	114.3	8.6	4.50	0.34	292	251	338	290
125	5	141.3	9.53	5.56	0.38	500	411	575	473
150	6	168.3	10.97	6.63	0.43	697	541	802	622

Figure 4: SD (DIN)

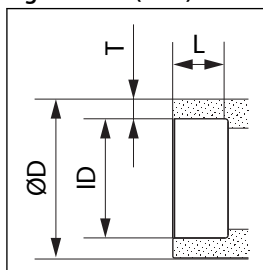

Table 10: Brazing EN 1254-5

Size		ID	L	ØD	T	ID	L	ØD	T	k_v -angle	k_v -straight	C_v -angle	C_v -straight
mm	in.	mm	mm	mm	mm	in.	in.	in.	in.	m ³ /h	m ³ /h	US _{gal} /min	US _{gal} /min
50	2	54	13.5	60.3	3.15	2.13	0.53	2.37	0.12	67	79	77	91
65	2½	64	13.5	73	4.5	2.52	0.53	2.87	0.18	103	91	119	105

Strainer FIA-140B 140 bar (2030 psi) series

Figure 5: SA (ASME)

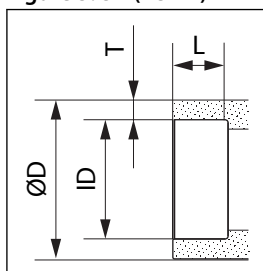

Table 11: Brazing ASME B16.50

Size		ID	L	ØD	T	ID	L	ØD	T	k_v -angle	k_v -straight	C_v -angle	C_v -straight
mm	in.	mm	mm	mm	mm	in.	in.	in.	in.	m ³ /h	m ³ /h	US _{gal} /min	US _{gal} /min
50	2	54	13.5	60.3	3.15	2 1/8	0.53	2.37	0.12	67	79	77	91
65	2 1/2	66.7	13.5	76.1	4.7	2 5/8	0.53	3.00	0.19	103	91	119	105

Material specification

FIA-140B 50-150 (2 – 6 in.)

Figure 6: FIA-140B 50-150 (2 – 6 in.)

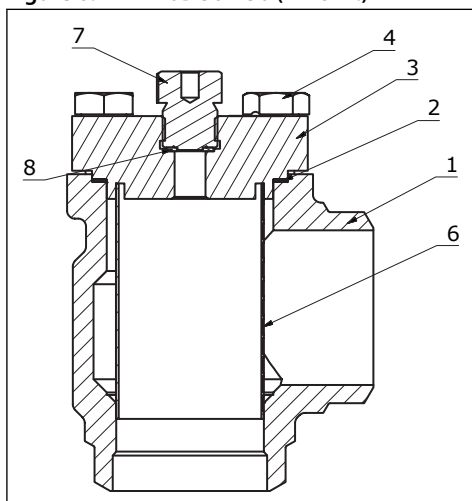

Table 12: Material and part list for DN 50-150

No.	Part	Material	EN	ISO	ASTM
1	Housing	Steel	DN 50-65: P285QH, 10222-4 DN 80-150: G20Mn5QT, 10213-3		DN 50-65: LF2, A350 DN 80-150: LCC, A352
2	Gasket	Graflit-EM			
3	Cover	Steel	DN 50-100: P275NL1 or 2, 10028-3 DN 125-150: P285QH, 10222-4		
4	Bolts	Steel	42CrMo4+QT, 10250-3		
5	Marking label	Aluminium			
6	Strainer insert	Stainless steel			
7	Pressure relief screw	Stainless steel			
8	Packing washer	Aluminium			

Dimensions and weights

FIA 50-150 (2 – 6 in.) in angleway and straightway version

Table 13: FIA 50 - 150 (2 – 6 in.) in angleway and straightway version

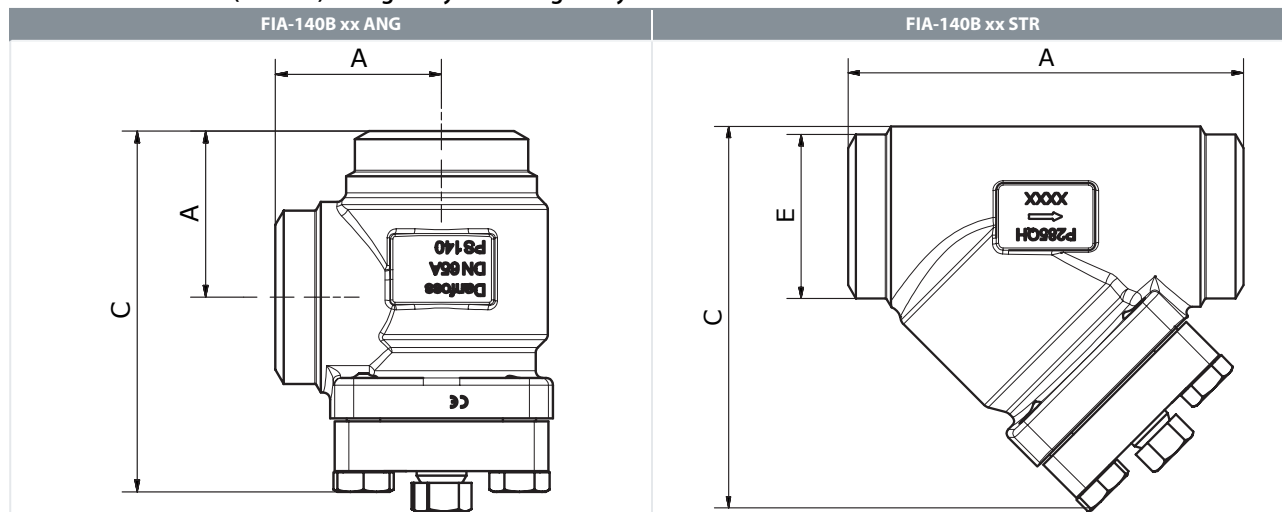

Table 14: FIA 50 - 150 (2 – 6 in.) in angleway and straightway version

Valve size		A	C	E	C	A	Weight [kg]
50	ANG	70	152				5.05
65	ANG	70	152				5
80	ANG	90	188				8.9
100	ANG	106	230				14.95
125	ANG	128	281.7				33.8
150	ANG	145	321.7				51.3
50	STR			60	171	176	7.1
65	STR			73	171	176	6.7
80	STR			89	212	216	10.7
100	STR			114	271	264	19.7
125	STR			139.7	333.9	322	42.4
150	STR			168.3	390.4	370	71.8

NOTE:

Specified weights are approximate values only.

Ordering

NOTE:

Please note that the type codes only serve to identify the valves, some of which may not form part of the standard product range. For further information please contact your local Danfoss Sales Company.

Table 15: Type codes

Connection	A	Butt-weld ANSI (B 36.10 Schedule 80)
	D	Butt-weld DIN (EN 10216-2)
	SA	Brazing ASME B16.50, 2 1/8" and 2 5/8"
	SD	Brazing EN 1254-5, 54 and 64 mm
Valve housing	ANG	Angle flow
	STR	Straight flow

Ordering FIA-140B valves from the parts program

IMPORTANT:

Where products need to be certified according to specific certification societies or where higher pressures are required, the relevant information should be included at the time of order.

Table 16: Ordering FIA-140B valves from the parts program

Size [DN]		Parts Program								Top complete
		Housing ⁽¹⁾								
mm	in.	ANG				STR				FIA-140B
		ANSI	DIN	SA	SD	ANSI	DIN	SA	SD	
50	2	148B5861	148B5861	148B6861	148B6861	148B5862	148B5862	148B6862	148B6862	148B6932 ⁽²⁾
65	2 1/2	148B6908	148B6910	148B6912	148B6914	148B6909	148B6911	148B6913	148B6915	148B6932
80	3	148B5971	148B5971			148B5972	148B5972			148B6933
100	4	148B6918	148B6918			148B6919	148B6919			148B6934
125	5	148B6922	148B6920			148B6923	148B6921			148B6935
150	6	148B6924	148B6924			148B6925	148B6925			148B6936

⁽¹⁾ Code numbers may cover more connection types (e.g. A/D) where standards and tolerances allow for it.

⁽²⁾ Same code number for DN 50-65

NOTE:

Please note that you have to order FIA housing, FIA top complete, strainer element and accessories separately.

Strainer element

Table 17: Strainer elements

FIA size		Pleated Strainer insert 50µ	Pleated Strainer insert 150µ	Pleated Strainer insert 250µ 72	Pleated Strainer insert 500µ 38
mm	in.	100 mesh	100 mesh	mesh	mesh
50	2	148H3414	148H3179	148H3184	148H3189
65	2 1/2	148H3415	148H3180	148H3185	148H3190
80	3	148H3416	148H3181	148H3186	148H3191
100	4	148H3417	148H3182	148H3187	148H3192
125	5	148H3418	148H3183	148H3188	148H3193
150	6	148H3419	148H3226	148H3293 ⁽¹⁾	

⁽¹⁾ 60 mesh

Accessories

Table 18: Accessories

Part	Accessory for	Code number
Magnet insert	FIA 65-100	148H3447
	FIA 125-150	148H3448
Filter bag	FIA 50-65	148H3151
	FIA 80	148H3152
	FIA 100	148H3153
	FIA 125	148H3154
	FIA 150	148H3155
	FIA 50-150	148H3450
Blind nut with gasket		

Certificates, declarations and approvals

The list contains all certificates, declarations, and approvals for this product type. Individual code number may have some or all of these approvals, and certain local approvals may not appear on the list.

Some approvals may change over time. You can check the most current status at danfoss.com or contact your local Danfoss representative if you have any questions.

Certificates, declarations and approvals

Table 19: Certificates, declarations and approvals

File name	Document type	Document topic	Approval Authority
033F0685.AN	EU Declaration	PED	Danfoss
033F0691.AH	Manufacturers Declaration	RoHS	Danfoss

Table 20: Certificates and declarations

	SVA/FIA-140B valves are approved according to the European standard specified in the Pressure Equipment Directive and are CE marked.
---	--

NOTE:

For further details / restrictions - see Installation guide.

Table 21: PED Categorization

Nominal bore	DN 50-100	DN 125-150
Classified for	Fluid group 2	
Category	I	II

Online support

Danfoss offers a wide range of support along with our products, including digital product information, software, mobile apps, and expert guidance. See the possibilities below.

The Danfoss Product Store



The Danfoss Product Store is your one-stop shop for everything product related—no matter where you are in the world or what area of the cooling industry you work in. Get quick access to essential information like product specs, code numbers, technical documentation, certifications, accessories, and more.

Start browsing at store.danfoss.com.

Find technical documentation



Find the technical documentation you need to get your project up and running. Get direct access to our official collection of data sheets, certificates and declarations, manuals and guides, 3D models and drawings, case stories, brochures, and much more.

Start searching now at www.danfoss.com/en/service-and-support/documentation.

Danfoss Learning



Danfoss Learning is a free online learning platform. It features courses and materials specifically designed to help engineers, installers, service technicians, and wholesalers better understand the products, applications, industry topics, and trends that will help you do your job better.

Create your Danfoss Learning account for free at www.danfoss.com/en/service-and-support/learning.

Get local information and support



Local Danfoss websites are the main sources for help and information about our company and products. Find product availability, get the latest regional news, or connect with a nearby expert—all in your own language.

Find your local Danfoss website here: www.danfoss.com/en/choose-region.

Spare Parts



Get access to the Danfoss spare parts and service kit catalog right from your smartphone. The app contains a wide range of components for air conditioning and refrigeration applications, such as valves, strainers, pressure switches, and sensors.

Download the Spare Parts app for free at www.danfoss.com/en/service-and-support/downloads.

Coolselector®2 - find the best components for you HVAC/R system



Coolselector®2 makes it easy for engineers, consultants, and designers to find and order the best components for refrigeration and air conditioning systems. Run calculations based on your operating conditions and then choose the best setup for your system design.

Download Coolselector®2 for free at coolselector.danfoss.com.

Danfoss A/S

Climate Solutions • danfoss.com • +45 7488 2222

Any information, including, but not limited to information on selection of product, its application or use, product design, weight, dimensions, capacity or any other technical data in product manuals, catalogues descriptions, advertisements, etc. and whether made available in writing, orally, electronically, online or via download, shall be considered informative, and is only binding if and to the extent, explicit reference is made in a quotation or order confirmation. Danfoss cannot accept any responsibility for possible errors in catalogues, brochures, videos and other material. Danfoss reserves the right to alter its products without notice. This also applies to products ordered but not delivered provided that such alterations can be made without changes to form, fit or function of the product.

All trademarks in this material are property of Danfoss A/S or Danfoss group companies. Danfoss and the Danfoss logo are trademarks of Danfoss A/S. All rights reserved.