

ENGINEERING  
TOMORROW



Technical Information

# LDU32

## Closed Circuit Axial Piston Transmission

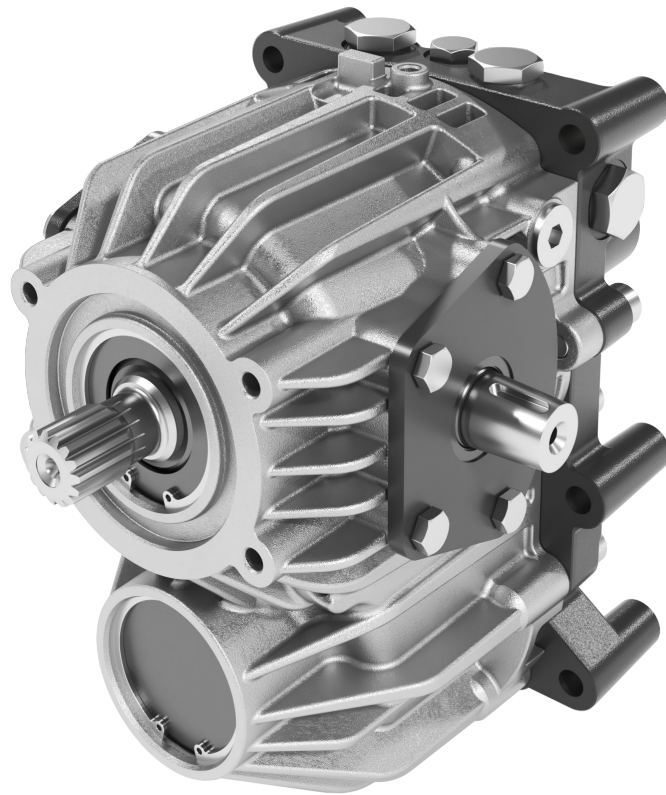

**Revision history***Table of revisions*

<b>Date</b>	<b>Changed</b>	<b>Rev</b>
January 2025	Updated Control Handle Requirements	0106
December 2024	Updated schematic, model code and installation drawings	0105
June 2024	Updated drawings and schematic	0104
June 2023	Fixed typo	0103
November 2020	Minor update in Fluid Selection	0102
November 2018	First edition	0101

## Contents

### General Description

Basic Design.....	4
Key Features.....	4
Typical Applications.....	4
Schematic diagram.....	4

### Technical Specification

Physical properties.....	5
Operation Parameters.....	5
Fluid Specifications.....	6

### Operations

Check / High Pressure Relief Valve .....	7
CPRV (Charge Pressure Relief Valve).....	8
Control.....	9
Direct Displacement Control.....	9
Control Handle Requirements.....	9

### Operating Parameters

Overview.....	11
Input / Output Speed.....	11
System Pressure.....	11
Input Power.....	11
Charge Pressure.....	11
Case pressure.....	12
Viscosity.....	12
Temperature.....	12

### System Design Parameters

Filtration System .....	13
Filtration.....	14
Charge Filtration.....	14
Independent Braking System.....	14
Fluid Selection.....	15
Reservoir.....	15
Case Drain.....	15
Charge Flow.....	16
Bearing Loads and Life.....	16
Applications with External Shaft Loads.....	16
Input Shaft.....	17
Shaft Torque Rating and Spline Lubrication.....	18
Shaft Availability.....	18
Sizing Equations.....	19

### Model Code

Model Code: A - H.....	20
Model Code: J - M.....	21
Model Code: N - Z.....	22

### Installation Drawings

Installation Drawings LDU32.....	23
Shaft Availability and Torque Ratings: Input Shaft/PTO Shaft.....	25

**General Description**

**Basic Design**

LDU32 is a kind of U-style HST hardware, including a closed circuit variable displacement piston pump with DDC (Direct displacement control) and a fixed motor. LDU32 is specially designed with optimized performance, size, and cost, in order to fulfill the demand of the mobile applications marketplace. This document provides the detailed specifications and features for LDU32.

**Key Features**

- Easy to use design as Complete Hydrostatic Transmission package for Turf care machines & Compact Utility Tractors up to 29.8kw[40HP]
- Compact design
- U-style layout in One housing with Z-shaft configuration
- Require external charge
- Best in class Efficiency...Can reach approximately 75% overall efficiency
- Longer life kit, Higher Duty Cycle capability in the most compact design in this class of HST
- Low control arm operating force
- Serviced by a Worldwide Network of Danfoss

**Typical Applications**

- Compact utility tractor

**Schematic diagram**

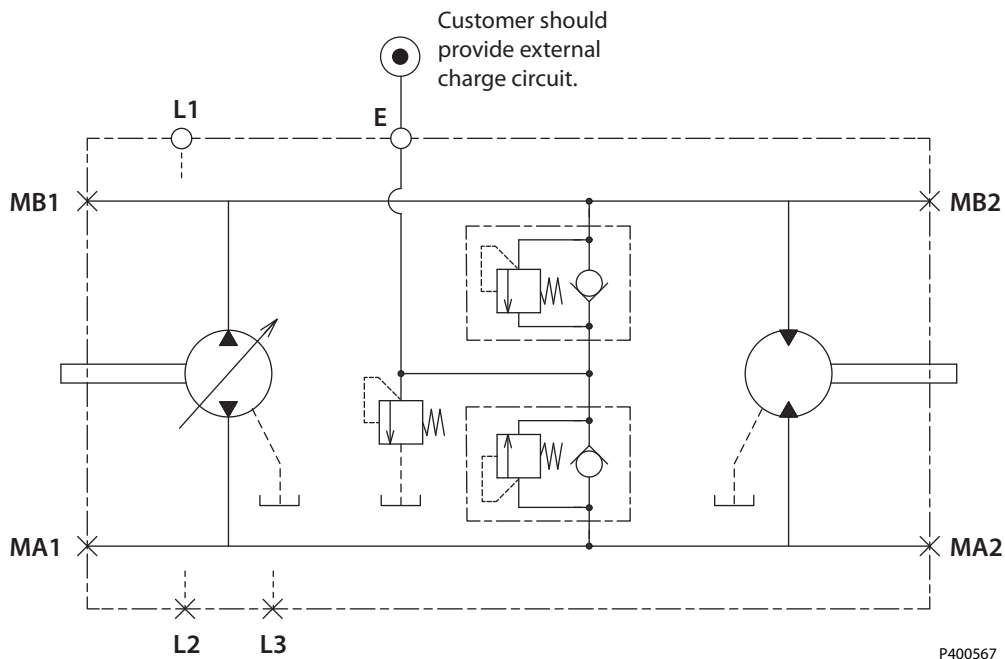

\*L1, L2 and L3 are (Case) Drain ports.

\*E is Charge Inlet port. Customer should provide external charge circuit.

## Technical Specification

### Physical properties

Features		Units	LDU32
Displacement	Pump side <sup>1</sup>	cm <sup>3</sup> /rev [in <sup>3</sup> /rev]	0-31.5 [0-1.92]
	Motor side		31.5 [1.92]
Recommended charge pump displacement for external charge supply		cm <sup>3</sup> /rev [in <sup>3</sup> /rev]	6-8 [0.37-0.49]
Torque at maximum displacement (theoretical)		N•m/bar [lbf•in/1000 psi]	0.51 [310.8]
Mass moment of inertia of rotating components	Pump side	kg•m <sup>2</sup> [slug•ft <sup>2</sup> ]	0.0019 [0.0014]
	Motor side		0.0019 [0.0014]
Weight dry		kg [lb]	21 [46.3]
Oil volume	Case only	liter [US gal]	1.4 [0.37]
	With passage		1.6 [0.42]
Installation			See <a href="#">Installation Drawings LDU32</a> on page 23
Input shaft rotation			Clockwise
Ports (ISO 11926-1)			See <a href="#">Installation Drawings LDU32</a> on page 23
Input shafts and PTO shafts			See <a href="#">Shaft Availability and Torque Ratings: Input Shaft/PTO Shaft</a> on page 25
Output shaft			See <a href="#">Shaft Availability and Torque Ratings: Input Shaft/PTO Shaft</a> on page 25
Control type			DDC

<sup>1</sup> Max Swash angle is 18 deg.

### Operation Parameters

Features		Units	LDU32
Input speed	Minimum	min <sup>-1</sup> (rpm)	1000
	Rated		3200
	Maximum		3400
System pressure	Maximum working pressure	bar [psi]	300 [4350]
	Maximum pressure		345 [5004]
Input power	Maximum	kw [HP]	29.8 [40]
Charge pressure	Minimum	bar [psi]	5 [73]
Case pressure	Rated	bar [psi]	1 [14.5]
	Maximum		3 [43.5]

**Technical Specification**

**Fluid Specifications**

Features		Units	LDU32
Viscosity	Minimum	mm <sup>2</sup> /sec. [ SUS]	7 [49]
	Continuous		12-60 [66-280]
	Maximum		1600 [7500]
Temperature	Minimum	Degrees C [Degrees F]	-40 [-40]
	Recommended range		+82 [+180]
	Maximum		+104 [+220]
Filtration (recommended minimum)	Cleanliness per ISO 4406		22/18/13
	Efficiency (charge pressure filtration)	β-ratio	β <sub>15-20</sub> =75(β <sub>10</sub> ≥10)
	Efficiency (suction and return line filtration)		β <sub>35-45</sub> =75(β <sub>10</sub> ≥2)
	Recommended inlet screen mesh size	μm	100-125

## Operations

### Check / High Pressure Relief Valve

LDU32 is equipped with a combination high pressure relief and charge check valve. The high-pressure relief function is a dissipative (with heat generation) pressure control valve for the purpose of limiting excessive system pressures. The charge check function acts to replenish the low-pressure side of the working loop with charge oil. Each side of the transmission loop has a dedicated HPRV valve that is non-adjustable with a factory set pressure. When system pressure exceeds the factory setting of the valve, oil is passed from the high pressure system loop, into the charge gallery, and into the low pressure system loop via the charge check.

The pump order code allows for different pressure settings to be used at each system port. HPRV valve with orifice is available to gain wider neutral dead-band. When HPRV valves with orifice are used, it is only for High pressure ports when vehicle goes in reverse. The system pressure order code for pumps with only HPRV is a reflection of the HPRV setting.

The system pressure order code for pumps configured with pressure limiter and HPRV is a reflection of the pressure limiter setting.

#### Check/High pressure relief valve with orifice

As an option, LDU32 offers Check / HPRV with an orifice produce a larger neutral deadband.

In some applications, it is desirable to use Check / HPRV with an orifice to expand null dead band, which would help provide a larger margin of safety for vehicle movement in neutral and provide easier adjustment of the vehicle linkage for machine neutral. The orifice connects the working loop, which is a main hydraulic circuit, to a charge circuit. It always allows some internal leakage to ensure the expanding null dead band around neutral position of control shaft. However, it decreases the volumetric efficiency, particularly at high system pressure in the working loop. Check / HPRV with an orifice has possibility to increase downhill creep. It is recommended to install the orifice in a specific working loop, which is pressurized when the vehicle moves in reverse.

*The HPRV are set at the following flow rates*

Check/HPRV without orifice	5 l/min [1.3 US gal/min]
Check/HPRV with orifice	17 l/min [4.5 US gal/min]

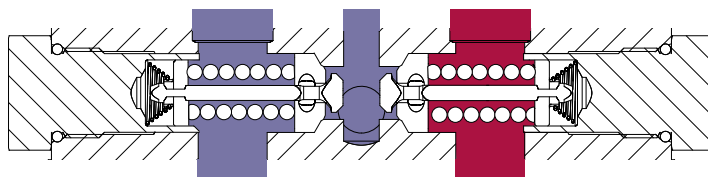

P400005

#### **Caution**

HPRV's are factory set at a low flow condition. Any application or operating condition which leads to elevated HPRV flow will cause a pressure rise with flow above a valve setting. Consult factory for application review.

**Operations**

**CPRV (Charge Pressure Relief Valve)**

The charge pressure relief valve maintains charge pressure at a designated level above case pressure. The charge pressure relief valve is a direct acting poppet valve which opens and discharges fluid to the HST case when pressure exceeds a designated level. For external charge flow the CPRV is set according to below table. The charge pressure relief valve setting is specified on the model code of the pump.

*Charge Pressure Relief Valve settings for external charge supply*

	Flow l/min [US gal/min]
LDU 32	13.8 [3.6]

*Charge Pressure Relief Valve Function*

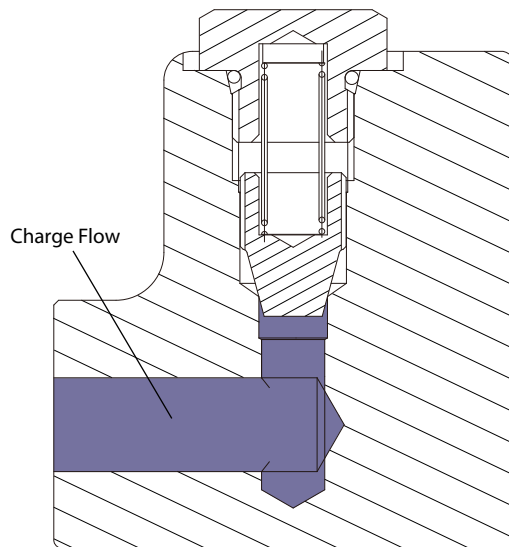

P400565



## Operations

### Control

#### Direct Displacement Control

LDU32 features Direct Displacement Control (DDC). The swashplate angle is set directly by a control lever or linkage attached directly to the swashplate control arm. Control lever movement changes the speed and rotating direction of the motor by increasing or decreasing the swashplate angle.

The control input shaft is configurable on both of left and right hand side of LDU32.

#### Control Handle Requirements

Maximum allowable control arm torque is 79.1 N·m [700 lbf·in]. The approximate torque necessary to rotate the control arm at 300 bar system operating pressure and 3000 rpm is 30 N·m with the standard valveplate. Minimum torque necessary to hold the swashplate at a zero angle for neutral is 2.3 N·m [20 in·lbf]. Neutral return spring force at neutral should be more than 18 N·m. The actual value will vary due to the influence of pump operating conditions. For mating dimensions, see [Installation Drawings](#) on page 23.

Input shaft rotation	CW			
	Right		Left	
Control arm rotation	CW	CCW	CW	CCW
Output rotation	CCW	CW	CW	CCW
High pressure port	MA	MB	MB	MA
Low pressure port	MB	MA	MA	MB

*Left hand side viewing from input shaft (when pump located upside)*

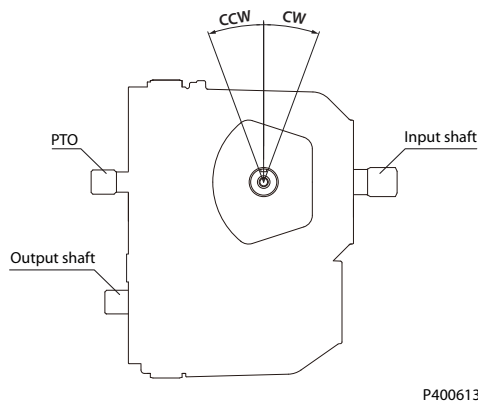

*Right hand side viewing from input shaft (when pump located upside)*

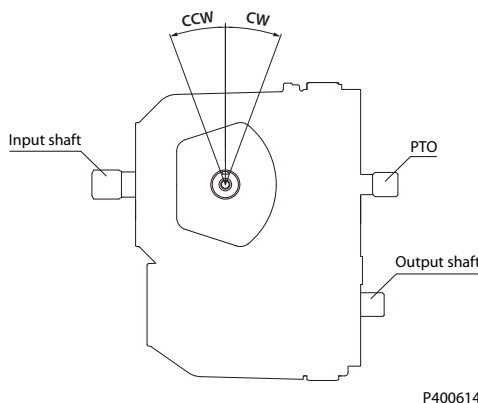

## Operations

 **Warning**

With no external forces applied to the swashplate control arm, internal hydraulic forces may not return the swashplate to the neutral position under all conditions of operation.

---

## Operating Parameters

### Overview

This section defines the operating parameters and limitations for LDU32 with regard to input speeds and pressures. For actual parameters, refer to [Operating Parameters](#) in the Technical Specifications section.

### Input / Output Speed

**Minimum speed** is the lowest input speed recommended during engine idle condition. Operating below minimum speed limits pump's ability to maintain adequate flow for lubrication and power transmission.

**Rated speed** is the highest input speed recommended at full power condition. Operating at or below this speed should yield satisfactory product life.

**Maximum speed** is the highest operating speed permitted. Exceeding maximum speed reduces product life and can cause loss of hydrostatic power and braking capacity. Never exceed the maximum speed limit under any operating conditions.

Operating conditions between rated speed and maximum speed should be restricted to less than full power and to limited periods of time. For most drive systems, maximum unit speed occurs during downhill braking or negative power conditions.

#### **Warning**

---

#### **Unintended vehicle or machine movement hazard.**

Exceeding maximum speed may cause a loss of hydrostatic drive line power and braking capacity. An independent braking system is required, redundant to the hydrostatic transmission, which is sufficient to stop and hold the vehicle or machine under all conditions of operation in the event of hydrostatic drive power loss.

---

### System Pressure

**System pressure** is the differential pressure measured between the gage ports Ma and Mb. It is the dominant operating variable affecting hydraulic unit life. High system pressure, which results from high load, reduces expected life. Hydraulic unit fatigue life depends on speed and normal operating—or weighted average—pressure that you can only determine from a duty cycle analysis.

**Maximum Working Pressure** is the highest recommended application pressure. Maximum working pressure is not intended to be a continuous pressure. Propel systems with application pressures at, or below, this pressure should yield satisfactory unit life given proper component sizing.

**Maximum pressure** (peak) is the highest intermittent pressure allowed under any circumstances. Applications with applied pressures between maximum working and maximum intermittent require factory approval with complete application, duty cycle, and life expectancy analysis.

---

All pressure limits are differential pressures referenced to low loop (charge) pressure. Subtract low loop pressure from gauge readings to compute the differential.

---

### Input Power

**Maximum continuous input power** is the highest recommended input power to HST excluding PTO output power.

### Charge Pressure

An internal charge relief valve regulates charge pressure. Charge pressure maintains a minimum pressure in the low side of the transmission loop. Charge pressure is the differential pressure above case pressure.

**Minimum charge pressure** is the lowest pressure safe working conditions allow in the system.

## Operating Parameters

### Case pressure

Under normal operating conditions, the rated case pressure must not be exceeded. During cold start case pressure must be kept below **maximum intermittent case pressure**. Size drain plumbing accordingly.

 **Caution**

---

#### Possible component damage or leakage

Operation with case pressure in excess of stated limits may damage seals, gaskets, and/or housings, causing external leakage. Performance may also be affected since charge and system pressure are additive to case pressure.

---

### Viscosity

Maintain fluid viscosity within the recommended range for maximum efficiency and bearing life.

**Minimum viscosity** should only occur during brief occasions of maximum ambient temperature and severe duty cycle operation. **Maximum viscosity** should only occur at cold start. Limit speeds until the system warms up. Refer to the [fluid specifications table](#).

### Temperature

1. Maintain fluid temperature within the limits shown in the Technical Specification section.

**Minimum temperature** relates to the physical properties of the component materials. Cold oil may affect the ability of the transmission to provide flow and transmit power.

**Continuous temperature** should not be exceeded for longer than 2 minutes (single event) or for more than 2% of the application duty cycle. Operating the unit at or below continuous temperature should yield satisfactory unit life. The application's cooling system shall be designed to maintain the oil temperature below the continuous temperature limit.

**Maximum intermittent temperature:** is based on material properties. Don't exceed it.

2. Measure maximum temperature at the hottest point in the system.

Refer to the [fluid specifications table](#) for data.

3. Ensure fluid temperature and viscosity limits are concurrently satisfied.

## System Design Parameters

### Filtration System

To prevent premature wear, ensure that only clean fluid enters the hydrostatic transmission circuit. A filter capable of controlling the fluid cleanliness to ISO 4406, class 22/18/13 (SAE J1165) or better, under normal operating conditions, is recommended. These cleanliness levels cannot be applied for hydraulic fluid residing in the component housing/case or any other cavity after transport.

Filtration strategies include suction or pressure filtration. The selection of a filter depends on a number of factors including the contaminant ingress rate, the generation of contaminants in the system, the required fluid cleanliness, and the desired maintenance interval. Filters are selected to meet the above requirements using rating parameters of efficiency and capacity.

Filter efficiency can be measured with a Beta ratio<sup>1</sup> ( $\beta_x$ ). For simple suction-filtered closed circuit transmissions and open circuit transmissions with return line filtration, a filter with a  $\beta$ -ratio within the range of  $\beta_{35-45} = 75$  ( $\beta_{10} \geq 2$ ) or better has been found to be satisfactory. For some open circuit systems, and closed circuits with cylinders being supplied from the same reservoir, a higher filter efficiency is recommended. This also applies to systems with gears or clutches using a common reservoir. For these systems, a charge pressure or return filtration system with a filter  $\beta$ -ratio in the range of  $\beta_{15-20} = 75$  ( $\beta_{10} \geq 10$ ) or better is typically required.

Because each system is unique, only a thorough testing and evaluation program can fully validate the filtration system. Please see *Design Guidelines for Hydraulic Fluid Cleanliness Technical Information, BC152886482150* for more information.

Cleanliness level and $\beta_x$ -ratio		
Filtration (recommended minimum)	Cleanliness per ISO 4406	22/18/13
	Efficiency (charge pressure filtration)	$\beta_{15-20} = 75$ ( $\beta_{10} \geq 10$ )
	Efficiency (suction and return line filtration)	$\beta_{35-45} = 75$ ( $\beta_{10} \geq 2$ )
	Recommended inlet screen mesh size	100 – 125 $\mu\text{m}$

<sup>1</sup> Filter  $\beta_x$ -ratio is a measure of filter efficiency defined by ISO 4572. It is defined as the ratio of the number of particles greater than a given diameter ("x" in microns) upstream of the filter to the number of these particles downstream of the filter.

## System Design Parameters

### Filtration

#### Charge Filtration

The pressure filter is remotely mounted in the circuit after the charge pump, as shown in the accompanying illustration.

Filters used in charge pressure filtration circuits must be rated to at least 34.5 bar [500 psi] pressure. Danfoss recommends locating a 100 - 125 µm screen in the reservoir or in the charge inlet line when using charge pressure filtration.

A filter bypass valve is necessary to prevent damage to the system. In the event of high pressure drop associated with a blocked filter or cold start-up conditions, fluid will bypass the filter. Avoid working with an open bypass for an extended period. We recommend a visual or electrical bypass indicator. Proper filter maintenance is mandatory.

#### Charge filtration

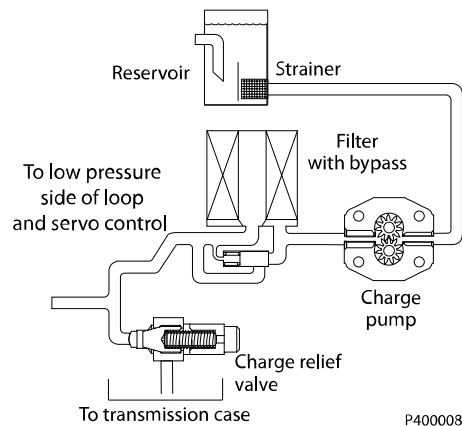

### Independent Braking System

Vehicle propel applications may require a provision for non-linear control input to reduce control sensitivity near neutral. Damping or frictional forces may be necessary to produce the desired control feeling.

These units do not include any neutral centering device for the swashplate. It is necessary to provide a force in the machine's control system that will hold the swashplate at the desired angle. A "fail safe" which will return the swashplate to the neutral in the event of linkage failure is recommended.

It is necessary for the application to have an independent braking system which is capable of stopping the vehicle in all working conditions. In the event of control linkage or direct displacement control sub-system failure (trunnion shaft, bearings, carriers, etc.), the independent braking system must be capable of stopping the vehicle which may be operating at full hydrostatic load.

#### Warning

##### **Unintended vehicle or machine movement hazard.**

The loss of hydrostatic drive line power, in any mode of operation (forward, neutral, or reverse) may cause the system to lose hydrostatic braking capacity. An independent braking system is required, redundant to the hydrostatic transmission, which is sufficient to stop and hold the vehicle or machine under all conditions of operation in the event of hydrostatic drive power loss.

## System Design Parameters

### Fluid Selection

Ratings and performance data are based on operating with hydraulic fluids containing oxidation, rust and foam inhibitors. These fluids must possess good thermal and hydrolytic stability to prevent wear, erosion, and corrosion of the components.

 **Caution**

---

Never mix hydraulic fluids of different types.

---

### Reservoir

The hydrostatic system reservoir should accommodate maximum volume changes during all system operating modes and promote de-aeration of the fluid as it passes through the tank.

A suggested minimum total reservoir volume is 58 of the maximum charge pump flow per minute with a minimum fluid volume equal to ½ of the maximum charge pump flow per minute. This allows 30 seconds fluid dwell for removing entrained air at the maximum return flow. This is usually adequate to allow for a closed reservoir (no breather) in most applications.

Locate the reservoir outlet (charge pump inlet) above the bottom of the reservoir to take advantage of gravity separation and prevent large foreign particles from entering the charge inlet line. A 100-125 µm screen over the outlet port is recommended.

Position the reservoir inlet (fluid return) to discharge below the normal fluid level, toward the interior of the tank. A baffle (or baffles) will further promote de-aeration and reduce surging of the fluid.

### Case Drain

A case drain line must be connected to one of the case outlets to return internal leakage to the system reservoir. Use the higher of the outlets to promote complete filling of the case and ensure that the housing remains full of oil at all times.

Since case drain fluid is typically the hottest fluid in the system, it is a good idea to return this flow to the reservoir via the heat exchanger

## System Design Parameters

### Charge Flow

Charge flow is required for LDU32. There is no internal charge pump option for LDU32, therefore external charge flow by an external pump is required. External charge flow should be provided through charge inlet ports "E" and regulated by charge relief valve.

Charge flow requirements for the LDU32 should be equivalent to a 6-8cc/rev charge pump, depending on pump input speed. Charge flow must not exceed 30 l/min.

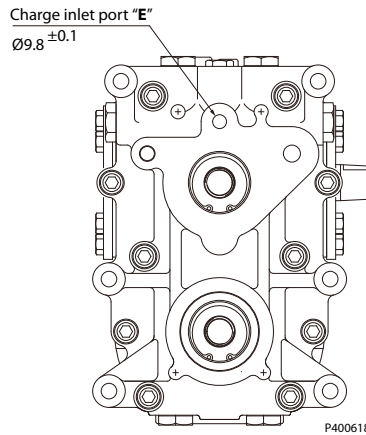

### Bearing Loads and Life

Bearing life is a function of speed, system pressure, charge pressure, and swashplate angle, plus any external side or thrust loads. The influence of swashplate angle includes displacement as well as direction. External loads are found in applications where the pump is driven with a side/thrust load (belt or gear) as well as in installations with misalignment and improper concentricity between the pump and drive coupling. All external side loads will act to reduce the normal bearing life of a pump. Other life factors include oil type and viscosity.

#### Applications with External Shaft Loads

LDU32 is designed with bearings that can accept some external radial and thrust loads. When external loads are present, the allowable radial shaft loads are a function of the load position relative to the Housing surface, the load orientation relative to the internal loads, and the operating pressures of the hydraulic unit. In applications where external shaft loads cannot be avoided, the impact on bearing life can be minimized by proper orientation of the load. Optimum pump orientation is a consideration of the net loading on the shaft from the external load, the pump rotating group.

- In applications where the pump is operated such that nearly equal amounts of forward vs. reverse swashplate operation is experienced; bearing life can be optimized by orientating the external side load at 90° or 270° such that the external side load acts 90° to the rotating group load (for details see drawing below).
- In applications where the pump is operated such that the swashplate is predominantly (> 75 %) on one side of neutral (ie vibratory, conveyor, typical propel); bearing life can be optimized by orientating the external side load generally opposite of the internal rotating group load. The direction of internal loading is a function of rotation and which system port has flow out.
- LDU32 is designed with bearings that can accept some thrust load such that incidental thrust loads are of no consequence. When thrust loads are anticipated the allowable load will depend on many factors and it is recommended that an application review be conducted.

Contact Danfoss for a bearing life review if external side loads are present.

Thrust loads should be avoided. Contact factory in the event thrust loads are anticipated.



## System Design Parameters

### Input Shaft

The **maximum allowable radial load (Re)** is based on the maximum external moment (Me) and the distance (L) from the mounting flange to the load. It is shown in the chart below.

$$Re = Me / L$$

- Me** Shaft moment
- L** Flange distance
- Re** External force to the shaft

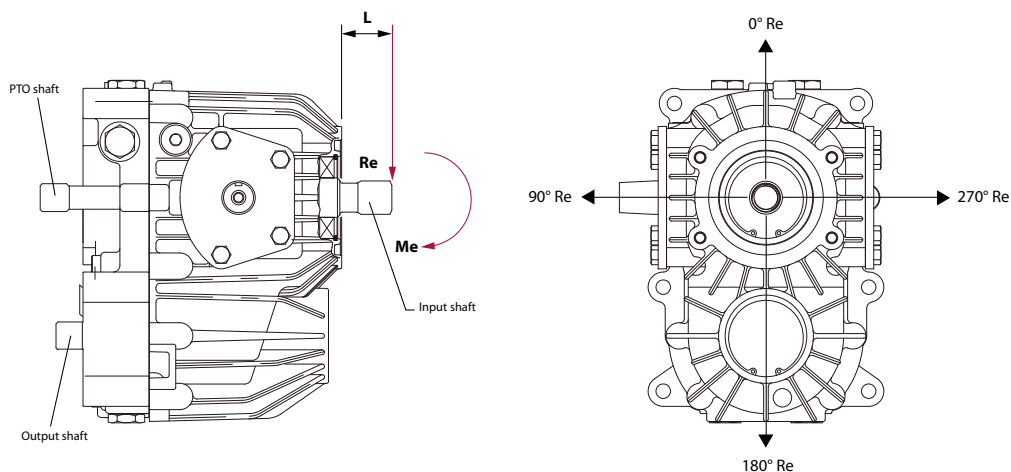

P400569

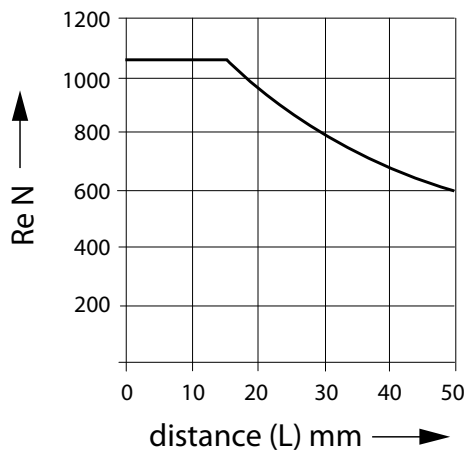

P400011

Danfoss recommends clamp-type couplings for applications with radial shaft loads

Contact your Danfoss representative for an evaluation of unit bearing life if you have continuously applied external loads exceeding 25 % of the maximum allowable radial load (Re) or the pump swashplate is positioned on one side of center all or most of the time.

### ***PTO shaft, Output shaft***

Avoid any load in either direction.

## System Design Parameters

### Shaft Torque Rating and Spline Lubrication

Maximum torque ratings are based on torsional fatigue strength considering 100,000 full load reversing cycles. However, a spline running in an oil-flooded environment provides superior protection from oxygen in addition to contaminant flushing. The rated torque of a flooded spline can increase to that of the maximum published rating. A flooded spline would be indicative of a pump driven by a pump drive or plugged into an auxiliary pad of a pump.

Maintaining a spline engagement at least equal to the pitch diameter will also maximize spline life. Spline engagements of less than  $\frac{3}{4}$  pitch diameter are subject to high contact stress and spline fretting.

### Shaft Availability

Alignment between the mating spline's pitch diameters is another critical factor in determining the operating life of a splined drive connection. *Plug-in*, or *rigid* spline drive installations can impose severe radial loads on the shaft. The radial load is a function of the transmitted torque and shaft eccentricity. Increased spline clearance will not totally alleviate this condition, but increased spline clearance will prevent mechanical interference due to misalignment or radial eccentricity between the pitch diameters of the mating splines. Maximize spline life by adding an intermediate coupling between the bearing supported splined shafts.

## System Design Parameters

### Sizing Equations

The following equations are helpful when sizing hydraulic transmissions. Generally, the sizing process is initiated by an evaluation of the machine system to determine the required transmission speed and torque to perform the necessary work function. Refer to *Selection of drive line components*, BC157786484430, for a more complete description of hydrostatic drive line sizing.

	Based on SI units		Based on US units	
Input torque	$M_p = \frac{V_{gp} \cdot \Delta p}{20 \cdot \pi \cdot \eta_{mp}}$	Nm	$M_p = \frac{V_{gp} \cdot \Delta p}{2 \cdot \pi \cdot \eta_{mp}}$	[lbf·in]
Input power	$P_p = \frac{M_p \cdot n_p}{9550}$	kW	$P_p = \frac{V_{gp} \cdot n_p \cdot \Delta p}{396\,000 \cdot \eta_{tp}}$	[hp]
Output torque	$M_m = \frac{V_{gm} \cdot \Delta p \cdot \eta_{mm}}{20 \cdot \pi}$	Nm	$M_m = \frac{V_{gm} \cdot \Delta p \cdot \eta_{mm}}{2 \cdot \pi}$	[lbf·in]
Output power	$P_m = \frac{M_m \cdot n_m}{9550}$	kW	$P_m = \frac{V_{gm} \cdot n_m \cdot \eta_{tm}}{396\,000}$	[hp]

Where;

$V_{gp}$	Pump displacement per rev. cm <sup>3</sup> [in <sup>3</sup> ]
$V_{gm}$	Motor displacement per rev. cm <sup>3</sup> [in <sup>3</sup> ]
$\Delta p$	$p_{HD} - p_{ND}$ bar [psi]
$\eta_{mp}$	Pump Mechanical-hydraulic (Torque) efficiency
$\eta_{mm}$	Motor Mechanical-hydraulic (Torque) efficiency
$\eta_{tp}$	Pump Overall efficiency
$\eta_{tm}$	Motor Overall efficiency
$p_{HD}$	High pressure bar [psi]
$p_{ND}$	Low pressure bar [psi]
$n_p$	Input speed
$n_m$	Output speed

**Model Code**

**Model Code: A - H**

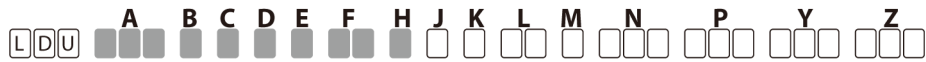

*A - Displacement & Z/U-Shaft Configuration*

Code	Description
32D	31.5 cc/rev displacement at maximum angle, Z-shaft configuration, Mounting location: Center section

*B - Pump Rotation*

Code	Description
R	Clockwise Rotation viewing from input shaft (CW)

*C - Valve Plate Pump*

Code	Description
A	Standard neutral seeking

*D - Control Arm Position*

Code	Description
L	Left-hand side viewing from input shaft (when pump located upside)
R	Right-hand side viewing from input shaft (when pump located upside)

*E - Control Arm*

Code	Description
A	24mm OD Taper Keyed (short)

*F - Pump Shaft (Input/PTO Shaft)*

Code	Description
AB	ANSI 16/32-15T (Input) / ANSI 24/48-19T (PTO)

*H - Output Shaft*

Code	Description
E	ANSI 24/48-19T

Technical Information  
**LDU32 Closed Circuit Axial Piston Transmission**

**Model Code**

**Model Code: J - M**

L
D
U

A
B
C
D
E
F
H
J
K
L
M
N
P
Y
Z

*J - Centersection*

Code	Description
E	Drain port: 12mm <sup>(A)</sup> , Charge port : 9.8mm <sup>(A)</sup>

<sup>(A)</sup> Connect charge inlet and drain line directly from LDU32 centersection with trans axle. See [Installation Drawings](#) on page 23 for detail.

*K - Charge Pump Displacement*

Code	Description
N	None

*L - Charge Relief Setting*

Code	Description
08	8 bar

*M - Bypass Valve*

Code	Description
N	None

**Model Code**

**Model Code: N - Z**



*N - Check & Relief Valve (Left-hand side viewing from Housing)*

Code	Description
00N	Poppet-type Check Valve
14N	High Pressure Relief Valve 140 bar
14A	High Pressure Relief Valve 140 bar w/ Orifice
17N	High Pressure Relief Valve 175 bar
17A	High Pressure Relief Valve 175 bar w/ Orifice
21N	High Pressure Relief Valve 210 bar
21A	High Pressure Relief Valve 210 bar w/ Orifice
23N	High Pressure Relief Valve 230 bar
25N	High Pressure Relief Valve 250 bar
28N	High Pressure Relief Valve 280 bar
30N	High Pressure Relief Valve 305 bar

*P - Check & Relief Valve (Right-hand side viewing from Housing)*

Code	Description
00N	Poppet-type Check Valve
14N	High Pressure Relief Valve 140 bar
14A	High Pressure Relief Valve 140 bar w/ Orifice
17N	High Pressure Relief Valve 175 bar w/ Orifice
17A	High Pressure Relief Valve 175 bar w/ Orifice
21N	High Pressure Relief Valve 210 bar w/ Orifice
21A	High Pressure Relief Valve 210 bar w/ Orifice
23N	High Pressure Relief Valve 230 bar w/ Orifice
25N	High Pressure Relief Valve 250 bar
28N	High Pressure Relief Valve 280 bar
30N	High Pressure Relief Valve 300 bar

*Y - Special Hardware Features*

Code	Description
NNN	Housing Configuration : Standard

*Z - Paint and Tag*

Code	Description
BNN	Black Paint, Danfoss Logo
NNN	No Paint, Danfoss Logo

## Installation Drawings

### Installation Drawings LDU32

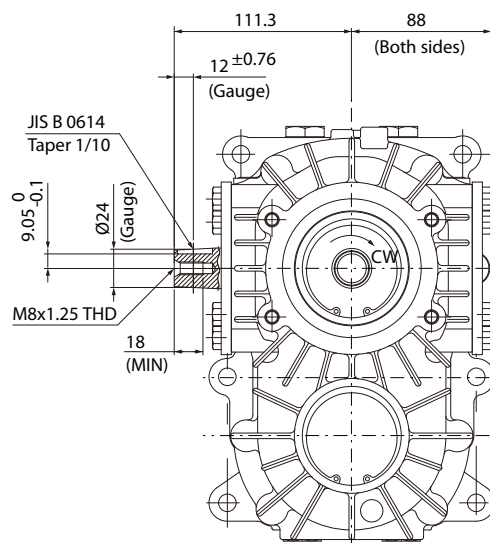
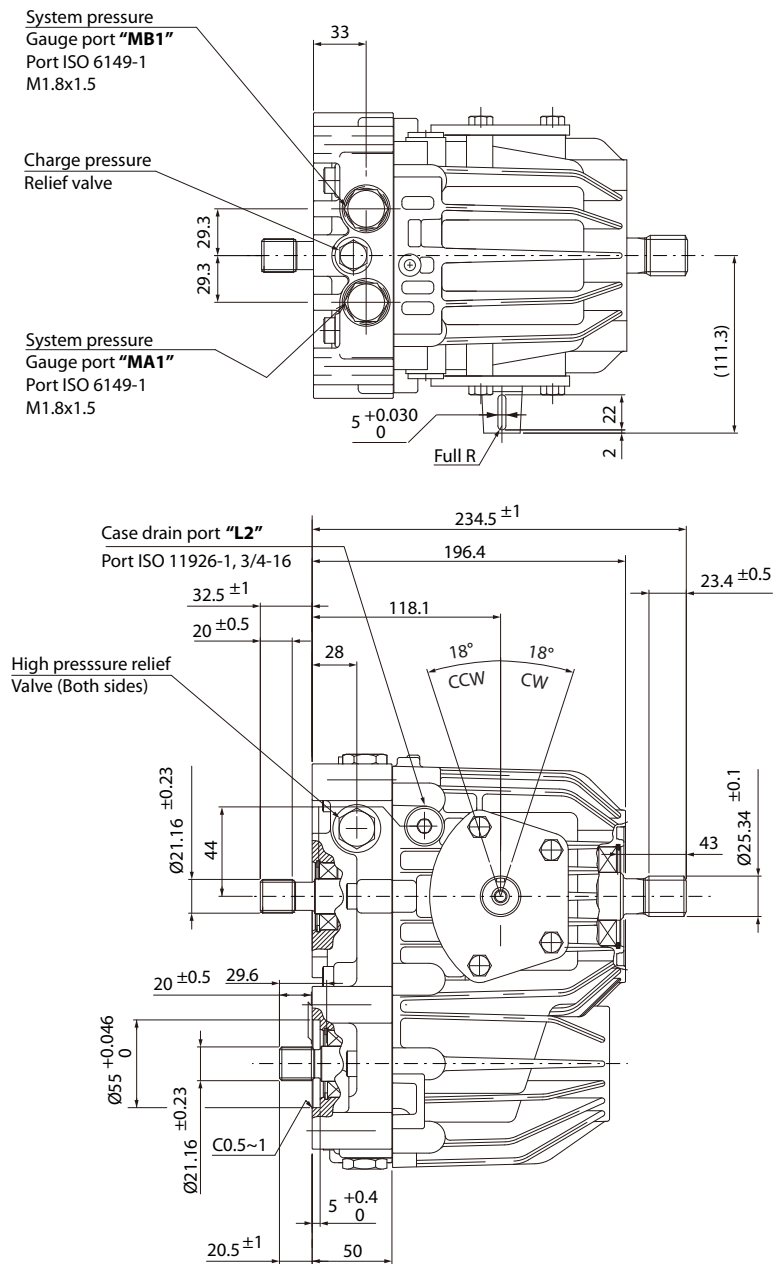

P400568

**Installation Drawings**

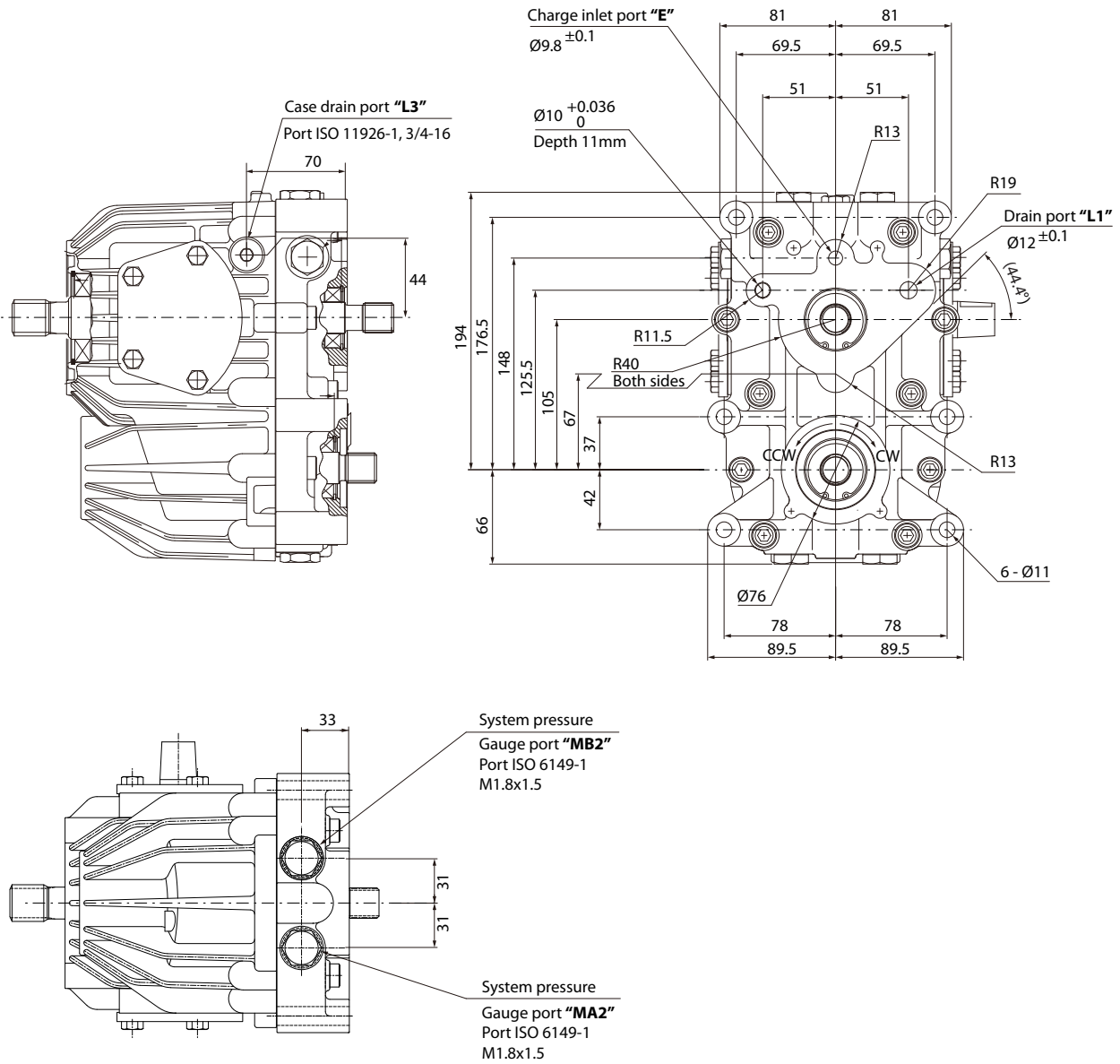

P400570

<b>Input shaft rotation</b>	<b>CW</b>	
<b>Control arm location</b>	<b>Left</b>	
Control arm rotation	CW	CCW
Output rotation	CW	CCW
High pressure port	MB	MA
Low pressure port	MA	MB



## Installation Drawings

### Shaft Availability and Torque Ratings: Input Shaft/PTO Shaft

#### Input shaft/PTO Shaft

Option	Spline	Torque Rating N·m [lbf·in]	
		Rated Torque	Maximum Torque
AB	ANSI 16/32-15T (Input)	181 [1602]	362 [3204]
	ANSI 24/48-19T (PTO)	119 [1053]	210 [1859]

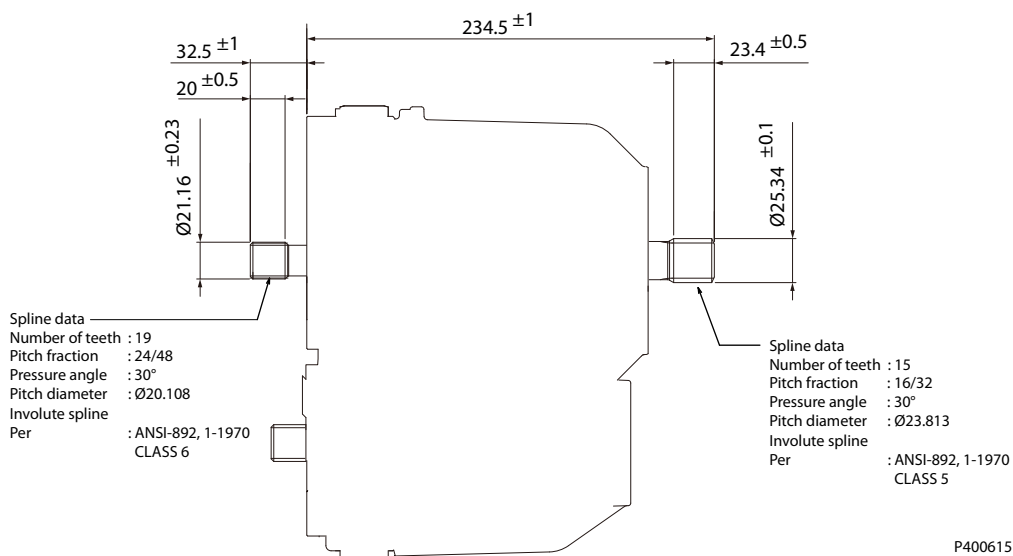

#### Output shaft

Option	Spline	Torque Rating N·m [lbf·in]	
		Rated Torque	Maximum Torque
E	ANSI 24/48-19T	119 [1053]	210 [1859]

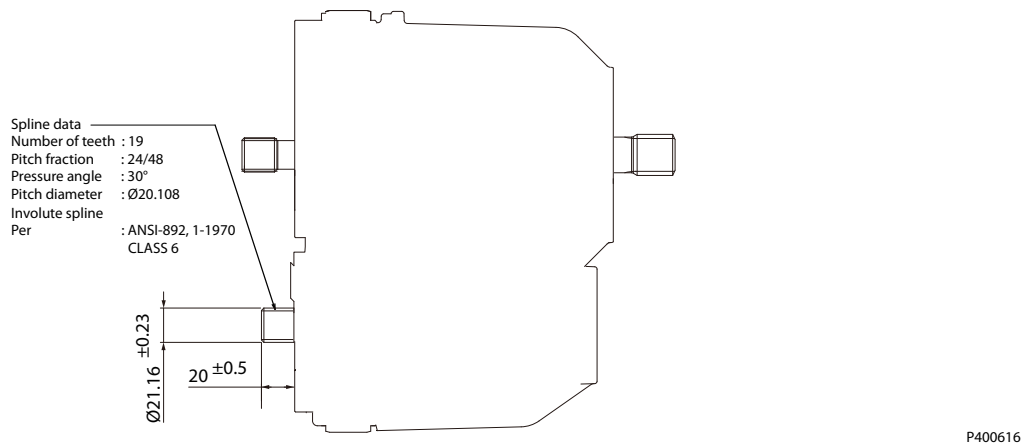

**Products we offer:**

- Cylinders
- Electric converters, machines, and systems
- Electronic controls, HMI, and IoT
- Hoses and fittings
- Hydraulic power units and packaged systems
- Hydraulic valves
- Industrial clutches and brakes
- Motors
- PLUS+1® software
- Pumps
- Steering
- Transmissions

**Danfoss Power Solutions** designs and manufactures a complete range of engineered components and systems. From hydraulics and electrification to fluid conveyance, electronic controls, and software, our solutions are engineered with an uncompromising focus on quality, reliability, and safety.

Our innovative products makes increased productivity and reduced emissions a possibility, but it's our people who turn those possibilities into reality. Leveraging our unsurpassed application know-how, we partner with customers around the world to solve their greatest machine challenges. Our aspiration is to help our customers achieve their vision — and to earn our place as their preferred and trusted partner.

**Go to [www.danfoss.com](http://www.danfoss.com) or scan the QR code for further product information.**

**Hydro-Gear**

[www.hydro-gear.com](http://www.hydro-gear.com)

**Daikin-Sauer-Danfoss**

[www.daikin-sauer-danfoss.com](http://www.daikin-sauer-danfoss.com)

**Danfoss  
Power Solutions (US) Company**  
2800 East 13th Street  
Ames, IA 50010, USA  
Phone: +1 515 239 6000

**Danfoss  
Power Solutions GmbH & Co. OHG**  
Krokamp 35  
D-24539 Neumünster, Germany  
Phone: +49 4321 871 0

**Danfoss  
Power Solutions ApS**  
Nordborgvej 81  
DK-6430 Nordborg, Denmark  
Phone: +45 7488 2222

**Danfoss  
Power Solutions Trading  
(Shanghai) Co., Ltd.**  
Building #22, No. 1000 Jin Hai Rd  
Jin Qiao, Pudong New District  
Shanghai, China 201206  
Phone: +86 21 2080 6201

Danfoss can accept no responsibility for possible errors in catalogues, brochures and other printed material. Danfoss reserves the right to alter its products without notice. This also applies to products already on order provided that such alterations can be made without subsequent changes being necessary in specifications already agreed. All trademarks in this material are property of the respective companies. Danfoss and the Danfoss logotype are trademarks of Danfoss A/S. All rights reserved.