

Data Sheet

2-step solenoid valve

Type **ICLX 32-150**

65 bar/52 bar valves used in wet return and suction lines for the opening against high differential pressure

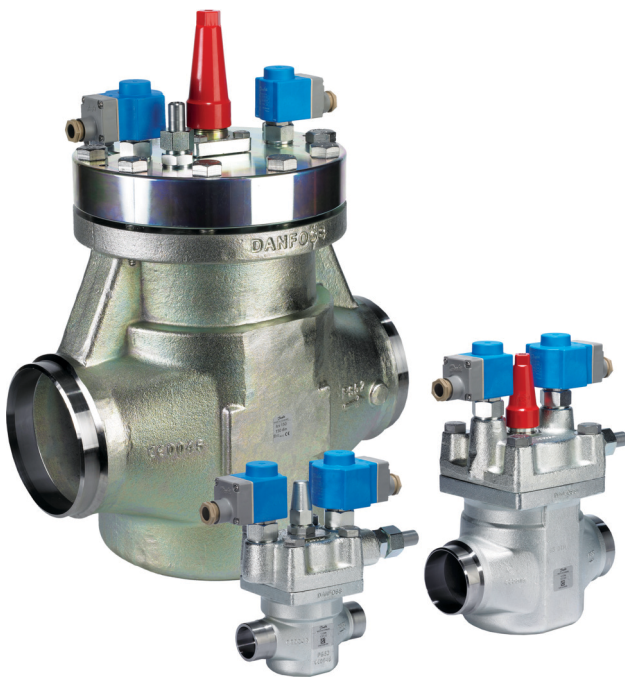

ICLX 2-step solenoid valves belong to the ICV family.

ICLX are used in suction lines for the opening against high differential pressure, e.g. after hot gas defrost in large industrial refrigeration systems with ammonia, fluorinated refrigerants or CO₂.

The small sizes are designed for MWP of 65 bar, while large sizes have MWP of 52 bar.

The ICLX valve is factory configured to open in 2 steps.

By following a simple procedure the valve can be configured to open in 1 step only.

In 2-step configuration, step 1 opens to approx. 10% of the capacity after the pilot solenoid valves are energized.

Step 2 opens automatically when the pressure differential across the valve has decreased to approx. 1.25 bar / 18 psig.

The ICLX valve comprises five main components: Valve body, top cover, function module and 2 pilot solenoid valves. On ICLX 32 – 150 the top cover and function module are factory assembled.

Features

- Designed for industrial refrigeration applications for a maximum working pressure of:
 - ICLX DN 32 to DN 65 (80): 65 bar / 943 psig.
NOTE: Operating valve MWP is dependent on MWP of installed pilots.
 - ICLX DN 100 to DN 150: 52 bar / 754 psig
- Applicable to HCFC, HFC, R717 (Ammonia) and R744 (CO₂)
- Can be used in chemical and petro-chemical applications
- Direct welded connections
- Connection types include butt weld, socket weld and solder connections
- Low temperature steel body
- Low weight and compact design
- Only one signal required for both pilot solenoid valves
- The ICLX main valve top cover can be oriented in any direction without the function of pilot valves being affected
- Especially suitable for systems where low pressure drop is required
- Stabilizes working conditions and eliminates pressure pulsations during opening after defrosting
- Provides safety against pressure "shocks" as the valve can only open fully when $\Delta p < 1.25 \text{ bar} / 18 \text{ psig}$
- Cavitation resistant valve seat
- Manual opening possible
- PTFE seat provides excellent valve tightness
- Service friendly design
- Classification: DNV, CRN, BV, EAC etc. To get an updated list of certification on the products please contact your local Danfoss Sales Company

Functions

Function

Figure 1: ICLX 32-65

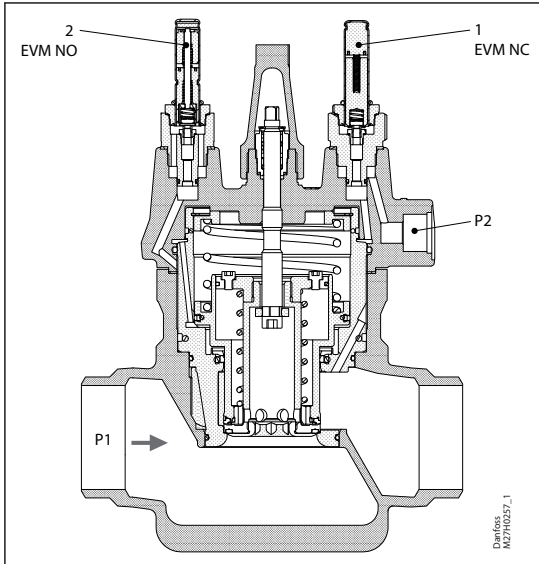
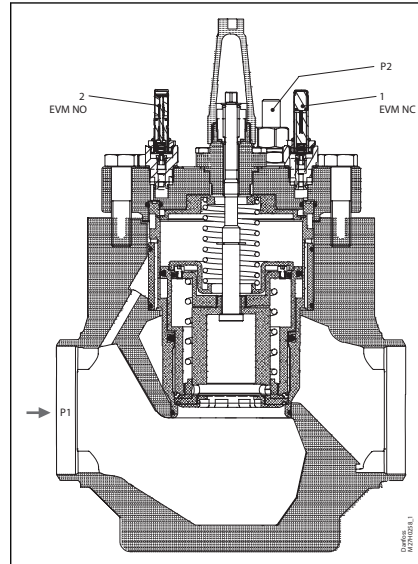

Figure 2: ICLX 100-150



The ICLX valve is used as a shut-off valve in suction lines to open after hot gas defrost.

The valve is a pilot controlled valve operated by an external pilot pressure source. This means that the valve can operate with no internal pressure differential (P_d) at all.

Low P_d is the key objective and makes the ICLX valve ideal for applications that are sensitive to differential pressure. Though P_d is kept low, it can still be quantified, and must be considered when choosing valve size. See section - [Selection of ICLX valve](#) - for the impact.

The main valve is provided with two pilot solenoid valves, as well as a nipple for connection to external pilot pressure.

The external pilot pressure line must be connected to a system pressure (p_2) which is at least 1.5 bar / 20 psi higher than the inlet pressure (p_1) of the valve. The difference between the external pilot pressure and the inlet pressure of the valve defines the maximum opening differential pressure (MOPD) of the ICLX.

The ICLX is kept open when power is applied to the coils placed on the EVM pilot solenoid valves pos. 1 and pos. 2.

The ICLX is closing and kept closed when the coils on EVM pilot solenoid valves pos. 1 and pos. 2 are de-energised.

The pilot solenoid valve (pos.1) allows external pilot pressure (p_2) to the bottom of the servo piston and thus opens the first step corresponding to approx. 10% of the valve capacity. At the same time the bleed spring will be compressed. This will start a pressure equalization of the inlet pressure (p_1) to the outlet pressure. When the differential pressure across the valve has fallen to approx. 1.25 bar / 18 psig the spring will be strong enough to open the second step and open the valve for full capacity.

This way high-pressure pulsations, which would occur when opening for full capacity in one step, can be avoided.

ICLX must not be used in pipe systems where the differential pressure across the main valve in open position can exceed 1 bar / 15 psig, otherwise the step two on the valve will close.

Figure 3: Two step opening principle

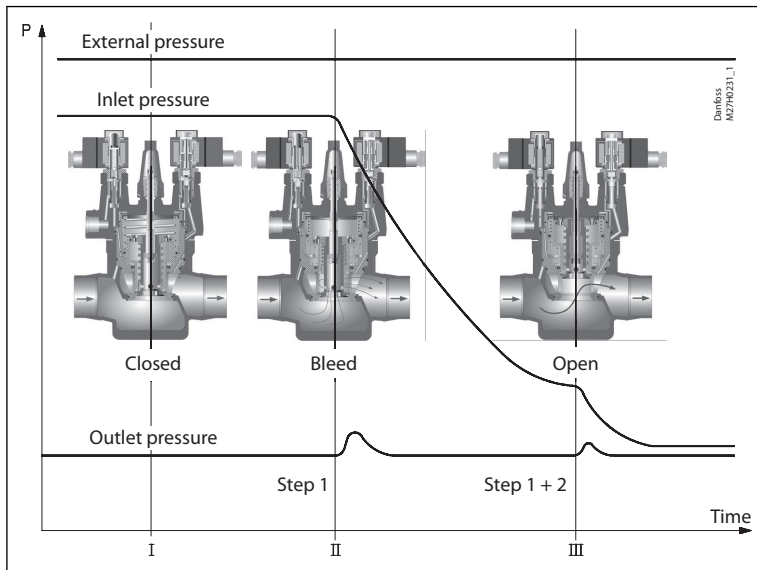

NOTE:

The ICLX valve is kept in its open position by hot gas. The hot gas condenses in the cold valve and creates liquid under the servo piston. When the pilot valves change status to close the ICLX, the pressure on the servo piston equalises with the suction pressure through the pilot valve (pos. 2). This equalisation takes time because condensed liquid is present in the valve.

The exact time taken from when the pilot valves change position to complete closing of the ICLX will depend on temperature, pressure, refrigerant and size of valve. Thus an exact closing time for the valves cannot be given but, in general, lower temperatures give longer closing times.

It is very important to take the closing times into consideration when hot gas defrost is performed on evaporators.

Steps must be taken to ensure that the hot gas supply valve is not opened before the ICLX in the suction line is completely closed. If the hot gas supply valve is opened before the ICLX in the suction line is closed, considerable energy will be lost and potentially dangerous situations might arise because of "liquid hammer". In ICLX valves, the spring-loaded second stage might be induced to hammer by gas and liquid being forced through the valve at $\Delta p > 1.5$ bar across the ICLX. The final result could be severe damage to the valve.

As a rule of thumb a closing time of 2 minutes can be used as a starting point. The optimum closing time for each individual system must be determined at initial start-up of the plant at intended operational conditions. It is recommended to check if the closing time needs to be changed when conditions changes (suction pressure, ambient temp. etc.) and closing time should be checked at service of the valve. Once the optimum closing time has been identified it is recommended to add a safety margin of 30 sec. to the optimum closing time.

Media

Refrigerants

Applicable to HCFC, HFC, R717 (Ammonia) and R744 (CO₂).

New refrigerants

Danfoss products are continually evaluated for use with new refrigerants depending on market requirements.

When a refrigerant is approved for use by Danfoss, it is added to the relevant portfolio, and the R number of the refrigerant (e.g. R513A) will be added to the technical data of the code number. Therefore, products for specific refrigerants are best checked at store.danfoss.com/en/, or by contacting your local Danfoss representative.

Product specification

Pressure and temperature

Table 1: Pressure and temperature data

Description	Values
Media temperature range	-60 °C / +120 °C / -76 °F / +248 °F
Max. working pressure	The valve is designed for a Max. working pressure: <ul style="list-style-type: none"> • Size DN 25 to DN 65 (80): 65 bar (943 psig)⁽¹⁾ • Size DN 100 to DN 150: 52 bar (754 psig)
Max. opening pressure differential (MOPD):	21 bar / 305 psi @ external pressure 1.5 bar / 22 psi higher than inlet pressure of the valve 40 bar / 580 psi @ external pressure 2 bar (30 psi) higher than inlet pressure of the valve

⁽¹⁾ MWP of the system main valve + pilots is defined by lowest MWP of the single pilot (not all pilots are designed for MWP of 65 bar).

 Table 2: C_v and K_v values

Unit	ICLX 32	ICLX 40	ICLX 50	ICLX 65	ICLX 100	ICLX 125	ICLX 150
k_v (m³/h)	22	29	47	82	151	225	390
C_v (US_{gal}/min)	25.5	33.6	54.5	95	175	261	452

Surface coating

Table 3: Surface coating

Description	Values
Surface protection	The ICLX external surface is zinc-chromated to provide good corrosion protection

Coils

Table 4: Coils

Description	Values
Coil requirements:	Both coils to be IP67 EVM NC: 10W AC (or higher) for MOPD up to 21 bar EVM NC: 20W AC for MOPD 21 – 40 bar EVM NO: 10W AC (or higher)

⁽¹⁾MWP of the system main valve + pilots is defined by lowest MWP of the single pilot (not all pilots are designed for MWP of 65 bar).

The ICLX Concept

The ICLX concept is developed to highest flexibility of direct welded connections. For valve sizes ICLV 32 – ICLV 65 a wide range of connection sizes and types is available. ICLV 100 – ICLV 150 are available in butt-weld DIN and butt-weld ANSI nominal sizes. The direct welded (non-flanged) connections secures low risk of leakage.

Design

Valve body and top cover material

Low temperature steel

There are seven valve bodies available

¹ MWP of the system main valve + pilots is defined by lowest MWP of the single pilot (not all pilots are designed for MWP of 65 bar).

2-step solenoid valve, Type ICLX 32-150

Table 5: ICV 32, 40, 50 and 65

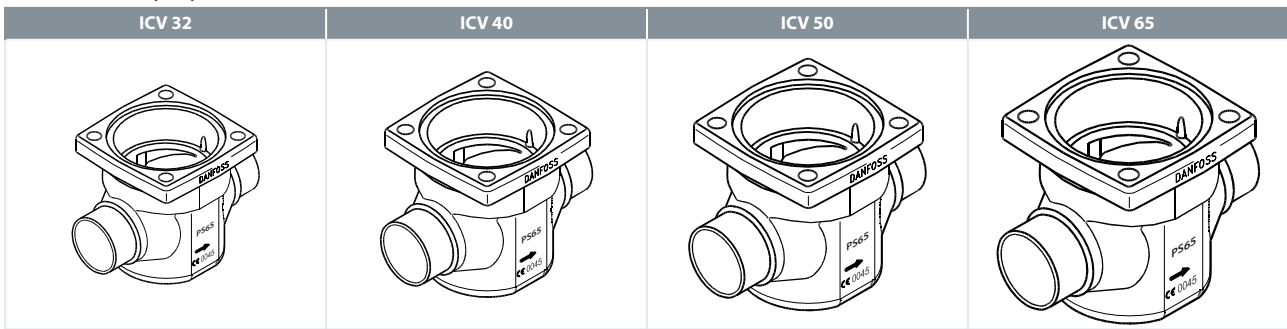
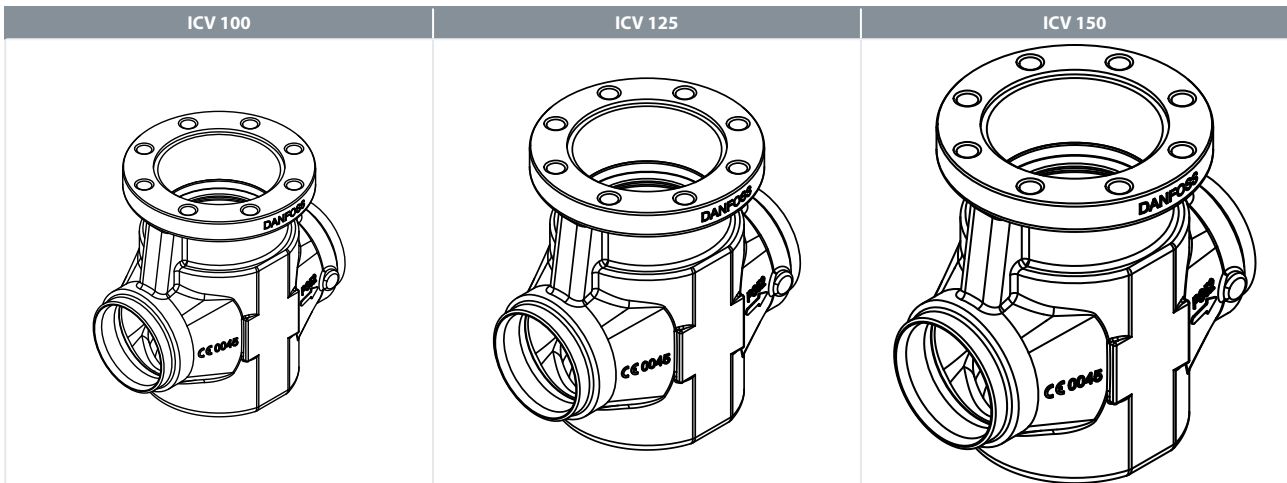

Table 6: ICV 100, 125 and 150



Material specification

Figure 4: ICLX 32-65

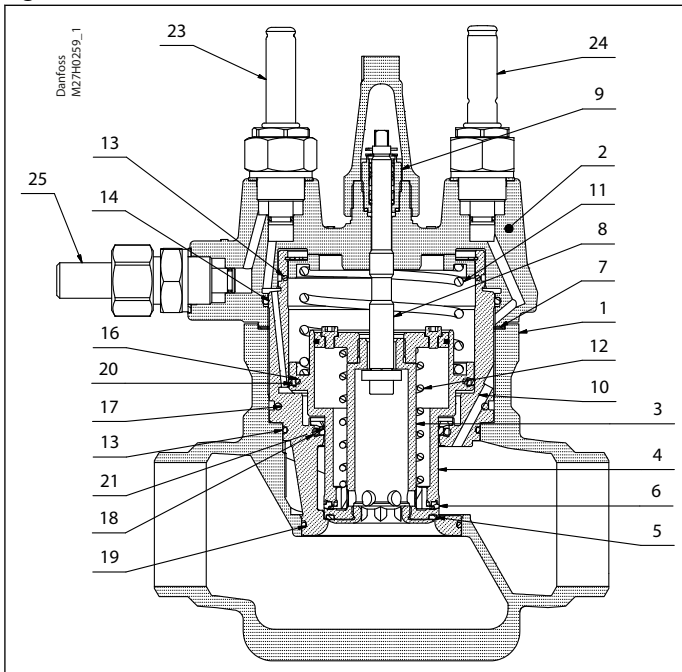
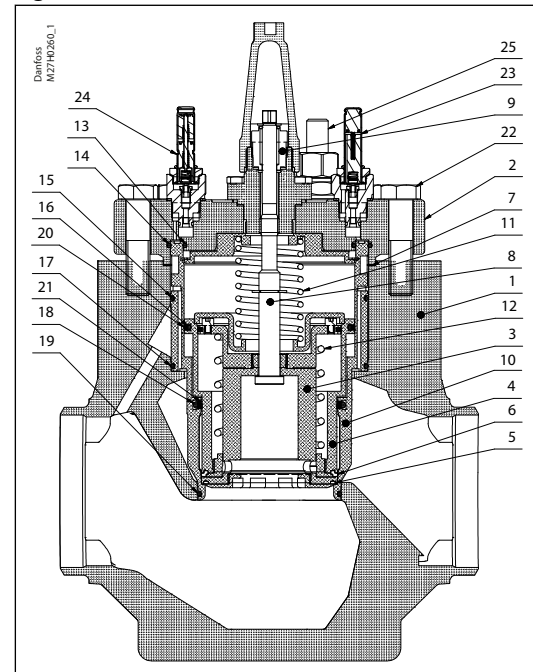

Figure 5: ICLX 100-150



2-step solenoid valve, Type ICLX 32-150

Table 7: Material specification

No.	Part	Material	EN	ASTM
1	Valve body	Low temperature steel	G20Mn5QT, EN 10213-3	LCC, A352
2	Top cover	ICLX 32-65: Low temperature steel ICLX 100-150: Low temperature steel	P285QH, EN 10222-4 P275NL2, EN 10028	LF2, A350
3	Main piston	Steel		
4	Bleed piston	Steel		
5	Seat plate main	PTFE		
6	Seat plate bleed	PTFE		
7	Gasket	Fibre, non-asbestos		
8	Spindle manual opener	Stainless steel		
9	Packing gland	Steel		
10	Insert	Steel		
11	Spring - main	Stainless steel		
12	Spring - bleed	Stainless steel		
13	O-ring	Chloroprene (neoprene)		
14	O-ring	Chloroprene (neoprene)		
15	O-ring	ICLX 100-150 only, Chloroprene (neoprene)		
16	O-ring	Chloroprene (neoprene)		
17	O-ring	Chloroprene (neoprene)		
18	O-ring	Chloroprene (neoprene)		
19	O-ring	Chloroprene (neoprene)		
20	Seal	PTFE		
21	Seal	PTFE		
22	Bolt	Stainless steel	A2-70 EN 1515-1	A2-70, B1054
23	EVM pilot NC			
24	EVM pilot NO			
25	External pressure inlet			

Connections

There is a wide range of connection types available with ICLX valves:

Table 8: Connections

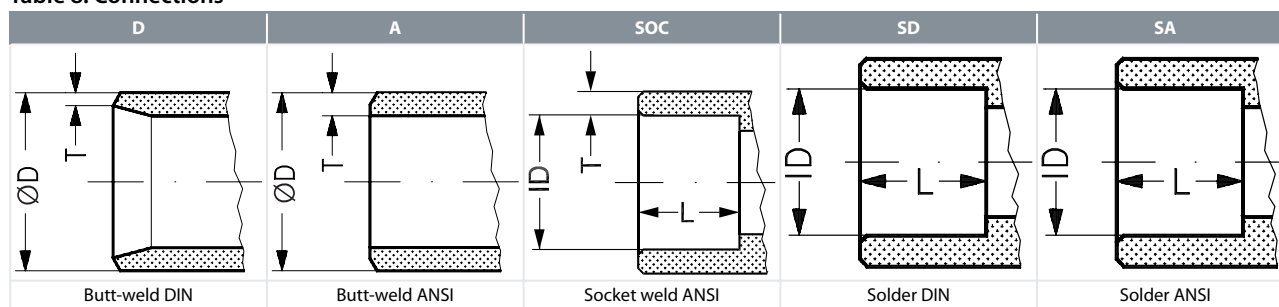

- **D**: Butt weld, EN 10220
- **A**: Butt weld, ANSI (B 36.10)
- **SOC**: Socket weld, ANSI (B 16.11)
- **SD**: Solder connection, EN 1254-1
- **SA**: Solder connection, ANSI (B 16.22)

The ICLX valves are approved in accordance with the European standard specified in the Pressure Equipment Directive and are CE marked.

Figure 6: D: Butt-weld (EN 10220)

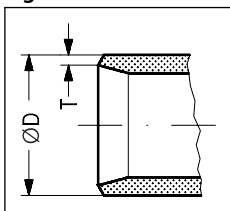

Table 9: D: Butt-weld (EN 10220)

Size mm	Size in.	ØD mm	T mm	ØD in.	T in.
32	1 ¼	42.4	2.6	1.669	0.102
40	1 ½	48.3	2.6	1.902	0.103
50	2	60.3	2.9	2.37	0.11
65	2 ½	76.1	2.9	3	0.11
80	3	88.9	3.2	3.5	0.13
100	4	114.3	3.6	4.5	0.14
125	5	140.7	4	5.5	0.16
150	6	168.3	6.3	6.6	0.25

Figure 7: A: Butt-weld ANSI (B 36.10)

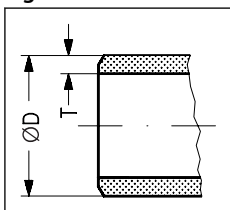

Table 10: A: Butt-weld ANSI (B 36.10)

Size mm	Size in.	ØD mm	T mm	ØD in.	T in.	Schedule
32	1 ¼	42.4	4.9	1.669	0.193	80
40	1 ½	48.3	5.1	1.902	0.201	80
50	2	60.3	3.9	2.37	0.15	40
65	2 ½	73	5.2	2.87	0.2	40
80	3	88.9	5.5	3.5	0.22	40
100	4	114.3	6	4.5	0.24	
125	5	140.7	6.5	5.5	0.26	
150	6	168.3	7.1	6.6	0.28	

Figure 8: SOC: Socket welding ANSI (B 16.11)

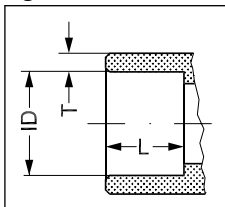

Table 11: SOC: Socket welding ANSI (B 16.11)

Size mm	Size in.	ØD mm	T mm	ØD in.	T in.	L mm	L in.
32	1 ¼	42.7	6.1	1.743	0.24	13	0.51
40	1 ½	48.8	6.6	1.921	0.26	13	0.51
50	2	61.2	6.2	2.41	0.24	16	0.63
65	2 ½	74	8.8	2.91	0.344	16	0.63

2-step solenoid valve, Type ICLX 32-150

Figure 9: SD: Soldering (EN 1254-1)

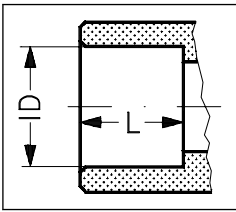

Table 12: SD: Soldering (EN 1254-1)

Size mm	Size in.	ID mm	ID in.	L mm	L in.
35		35.07		25	
42		42.07		28	
54		54.09		33	
76		76.1		33	

Figure 10: SA: Soldering (ANSI B 16.22)

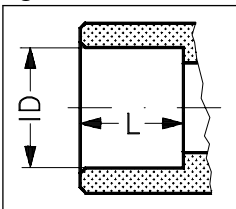

Table 13: SA: Soldering (ANSI B 16.22)

Size in.	ID in.	L in.
1 3/8	1.375	0.984
1 5/8	1.625	1.102
2 1/8	2.125	1.3
2 1/2	2.625	1.3

Valve selection based on capacity calculation

As for extended capacity calculations and valve selection based on capacities and refrigerants, please refer to Coolselector®2. Rated and extended capacities are calculated with the Coolselector®2 calculation engine to ARI standards with the ASEREP equations based on laboratory measurements of selected valves.

Download Coolselector®2 for free at coolselector.danfoss.com

Selection of ICLX valve

Figure 11: Wet suction line

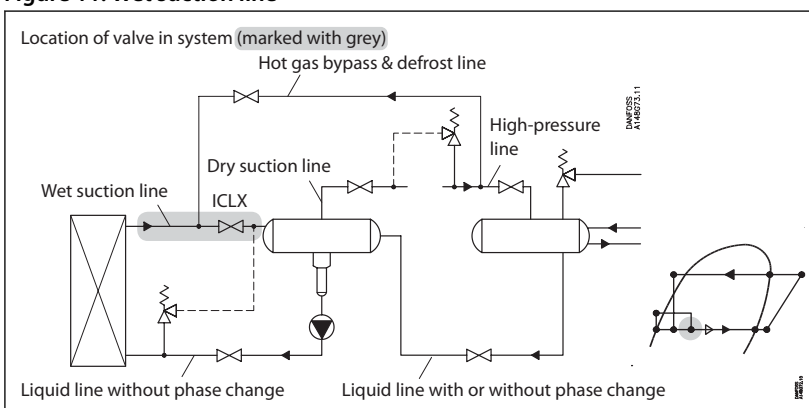

2-step solenoid valve, Type ICLX 32-150

Figure 12: Dry suction line

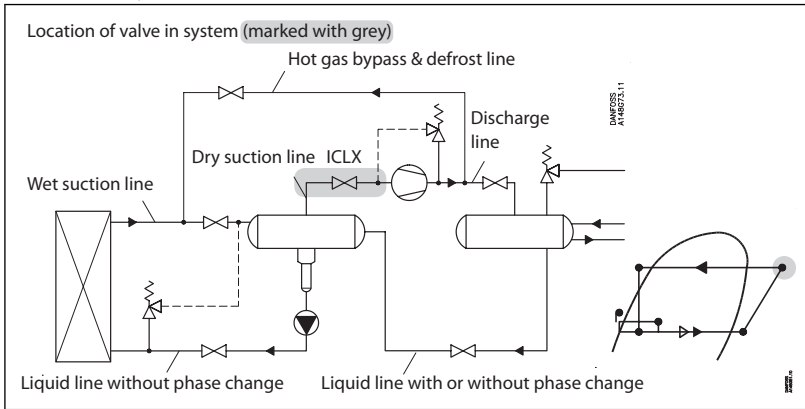

Dimensions and weight

ICLX 32-65

Figure 13: ICLX 32-65

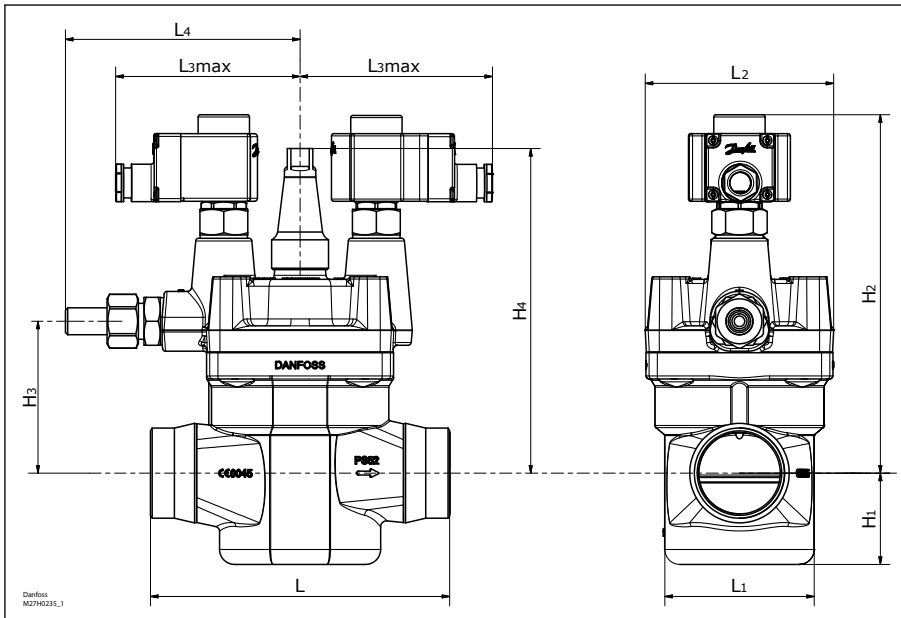

Table 14: ICLX 32

Type	L							
ICLX 32	32 D	40 D	32 A	40 A	32 SOC	35 SD	42 SD	42 SA
mm	145	145	145	145	148	148	148	148
in.	5.7	5.7	5.7	5.7	5.8	5.8	5.8	5.8

Table 15: ICLX 32

Type	L ₁	L ₂	L _{3max}		L ₄	H ₁	H ₂	H ₃	H ₄	Net weight
			10W	20W						
ICLX 32	75	104	125	135	159	43	193	82	168	9.9 kg
mm	75	104	125	135	159	43	193	82	168	9.9 kg
in.	3	4.1	4.9	5.3	6.3	1.7	7.6	3.2	6.6	21.8 lb

Table 16: ICLX 40

Type	L							
ICLX 40	40 D	50 D	40 A	50 A	40 SOC	42 SD	42 SA	
mm	160	180	160	180	180	180	180	
in.	6.3	7.1	6.3	7.1	7.1	7.1	7.1	

2-step solenoid valve, Type ICLX 32-150

Table 17: ICLX 40

Type	L ₁	L ₂	L ₃ max		L ₄	H ₁	H ₂	H ₃	H ₄	Net weight
			10W	20W						
ICLX 40										
mm	86	109	125	135	157	52	217	87	174	11.7 kg
in.	3.4	4.3	4.9	5.3	6.2	2	8.5	3.4	6.9	25.8 lb

Table 18: ICLX 50

Type	L					
ICLX 50	50 D	65 D	50 A	65 A	50 SOC	54 SD
mm	200	210	200	210	216	216
in.	7.9	8.3	7.9	8.3	8.5	8.5

Table 19: ICLX 50

Type	L ₁	L ₂	L ₃ max		L ₄	H ₁	H ₂	H ₃	H ₄	Net weight
			10W	20W						
ICLX 50										
mm	100	126	125	135	157	61	240	102	217	15.3 kg
in.	3.9	5	4.9	5.3	6.2	2.4	9.4	4	8.5	33.7 lb

Table 20: ICLX 65

Type	L						
ICLX 65	65 D	80 D	65 A	80 A	65 SOC	76 SD	67 SA
mm	230	245	230	245	230	245	245
in.	9.1	9.6	9.1	9.6	9.1	9.6	9.6

Table 21: ICLX 65

Type	L ₁	L ₂	L ₃ max		L ₄	H ₁	H ₂	H ₃	H ₄	Net weight
			10W	20W						
ICLX 65										
mm	130	141	125	135	163	69	257	123	234	20.3 kg
in.	5.1	5.6	4.9	5.3	6.4	2.7	10.1	4.8	9.2	44.7 lb

D = Butt-weld DIN, **A** = Butt-weld ANSI, **SOC** = Socket weld ANSI, **SD** = Solder DIN, **SA** = Solder ANSI

NOTE:

Specified weights are approximate values only.

ICLX 100-150

Figure 14: ICLX 100-150

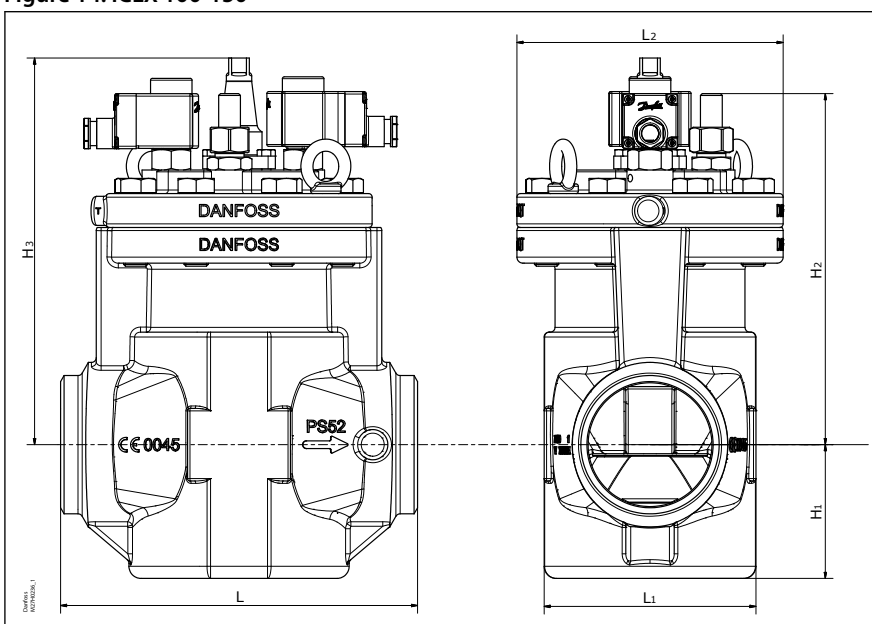

2-step solenoid valve, Type ICLX 32-150

Table 22: ICLX 100-150

Type		L	L ₁	L ₂	H ₁	H ₂	H ₃	Net weight
ICLX 100	mm	295	175	220	111	297	320	53.2 kg
	in.	11.6	6.9	8.7	4.4	11.7	12.6	117.3 lb
ICLX 125	mm	350	215	260	142	305	376	80.8 kg
	in.	13.8	8.5	10.2	5.6	12	14.8	178.1 lb
ICLX 150	mm	445	255	300	170	357	426	132.5 kg
	in.	17.5	10	11.8	6.7	14.1	16.8	292.1 lb

i NOTE:

Specified weights are approximate values only.

Ordering

ICLX 32

Ordering from the parts programme

i NOTE:

The ICLX function modules can only be used in housings produced in or after week 49 2012; thus the week code on the housing must be 4912 or higher.

Table 23: Example (select from table 24 and 25)

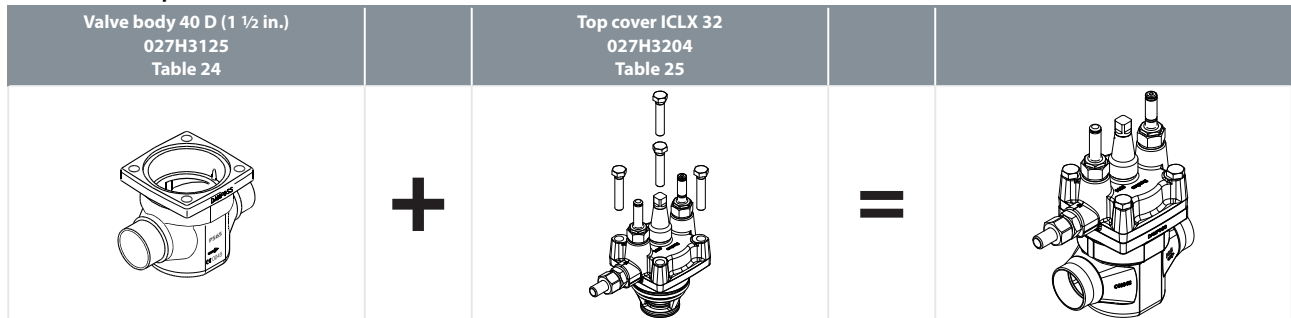

Figure 15: ICV 32

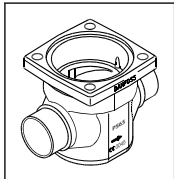

Table 24: ICV 32 valve body w/different connections

32 D (1 1/4 in.)	40 D (1 1/2 in.)	42 SA (1 5/8 in.)	42 SD (1 5/8 in.)
027H3120	027H3125	027H3127	027H3128
35 SD (1 3/8 in. SA)	32 A (1 1/4 in.)	32 SOC (1 1/4 in.)	40 A (1 1/2 in.)
027H3123	027H3121	027H3122	027H3126

Figure 16: ICLX 32

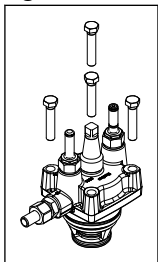

Table 25: ICLX 32 Function module / top cover

Description	Code Number
ICLX 32	027H3204 ⁽¹⁾

⁽¹⁾ Including external pilot connection, NC/NO pilot valves, gasket and O-rings

D = Butt-weld DIN

A = Butt-weld ANSI

SOC = Socket weld ANSI

SD = Solder DIN

SA = Solder ANSI

Ordering complete factory assembled valve

2-step solenoid valve, Type ICLX 32-150

Figure 17: ICLX 32

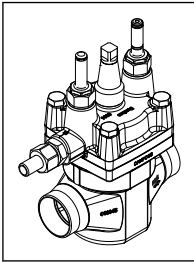

Table 26: (body, function module / top cover)

Type ICLX 32							
Available connections							
32 D (1 1/4 in.)	40 D (1 1/2 in.)	42 SA (1 5/8 in.)	42 SD (1 5/8 in.)	35 SD (1 3/8 in. SA)	32 A (1 1/4 in.)	32 SOC (1 1/4 in.)	40 A (1 1/2 in.)
027H3040	(2)	(2)	(2)	(2)	027H3041	027H3042	(2)

(2) Select from parts programme

ICLX 40

Ordering from the parts programme

NOTE:

The ICLX function modules can only be used in housings produced in or after week 49 2012; thus the week code on the housing must be 4912 or higher.

Table 27: Example (select from table 28 and 29)

Valve body A 40 (1 1/2 in.) 027H4121 Table 28		Top cover ICLX 40 027H4204 Table 29		
	+		=	

Figure 18: ICV 40

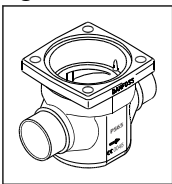
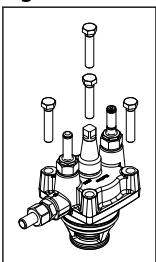

Table 28: ICV 40 valve body w/different connections

40 D (1 1/2 in.)	50 D (2 in.)	42 SA (1 5/8 in.)	42 SD (1 5/8 in.)
027H4120	027H4126	027H4124	027H4123
40 A (1 1/2 in.)	40 SOC (1 1/2 in.)	50 A (2 in.)	
027H4121	027H4122	027H4127	

Figure 19: ICLX 40



2-step solenoid valve, Type ICLX 32-150

Table 29: ICLX 40 Function module / top cover

Description	Code Number
ICLX 40	027H4204 ⁽¹⁾

⁽¹⁾ Including external pilot connection, NC / NO pilot valves, gasket and O-rings

- D** = Butt-weld DIN
- A** = Butt-weld ANSI
- SOC** = Socket weld ANSI
- SD** = Solder DIN
- SA** = Solder ANSI

Ordering complete factory assembled valve

Figure 20: ICLX 40

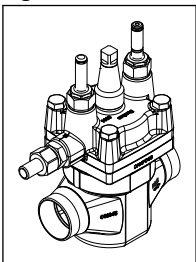

Table 30: (body, function module / top cover)

Type ICLX 40						
Available connections						
40 D (1 1/2 in.)	50 D (2 in.)	42 SA (1 5/8 in.)	42 SD (1 3/8 in.)	40 A (1 1/2 in.)	40 SOC (1 1/2 in.)	50 A (2 in.)
027H4040	(2)	(2)	(2)	027H4041	027H4042	(2)

⁽²⁾ Select from parts programme

ICLX 50

Ordering from the parts programme

NOTE:

The ICLX function modules can only be used in housings produced in or after week 49 2012; thus the week code on the housing must be 4912 or higher.

Table 31: Example (select from table 32 and 33)

Valve body 50 D (2 in.) 027H5120 Table 32		Top cover ICLX 50 027H5204 Table 33		
	+		=	

Figure 21: ICV 50

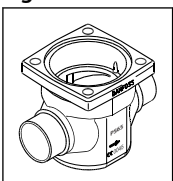

2-step solenoid valve, Type ICLX 32-150

Table 32: ICLX 50 valve body w/different connections

50 D (2 in.)	65 D (2 1/2 in.)	54 SD (2 1/8 in. SA)	50 A (2 in.)
027H5120	027H5124	027H5123	027H5121
50 SOC (2 in.)	65 A (2 1/2 in.)	50 A (2 in.)	
027H5122	027H5125		

Figure 22: ICLX 50

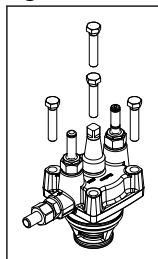

Table 33: ICLX 50 Function module / top cover

Description	Code Number
ICLX 50	027H5204 ⁽¹⁾

⁽¹⁾ Including external pilot connection, NC/NO pilot valves, gasket and O-rings

D = Butt-weld DIN

A = Butt-weld ANSI

SOC = Socket weld ANSI

SD = Solder DIN

SA = Solder ANSI

Ordering complete factory assembled valve

Figure 23: ICLX 50

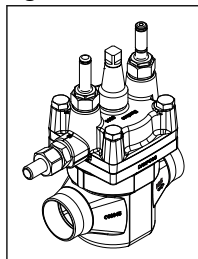

Table 34: (body, function module / top cover)

Type ICLX 50					
Available connections					
50 D (2 in.)	65 D (2 1/2 in.)	54 SD (2 1/8 in. SA)	50 A (2 in.)	50 SOC (2 in.)	65 A (2 1/2 in.)
027H5040	⁽²⁾	⁽²⁾	027H5041	027H5042	⁽²⁾

⁽²⁾ Select from parts programme

ICLX 65

Ordering from the parts programme

NOTE:

The ICLX function modules can only be used in housings produced in or after week 49 2012; thus the week code on the housing must be 4912 or higher.

2-step solenoid valve, Type ICLX 32-150

Table 35: Example (select from table 36 and 37)



Figure 24: ICV 65

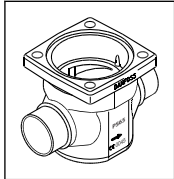

Table 36: ICV 65 valve body w/different connections

65 D (2 1/2 in.)	65 A (2 1/2 in.)	80 D (3 in.)	80 A (3 in.)
027H6120	027H6121	027H6126	027H6127
67 SA (2 5/8 in.)	76 SD (3 in.)	65 SOC (2 1/2 in.)	
027H6125	027H6124	027H6123	

Figure 25: ICLX 65

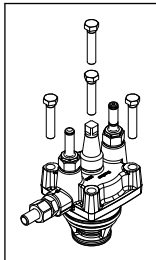

Table 37: ICLX 65 Function module / top cover

Description	Code Number
ICLX 65	027H6204 ⁽¹⁾

⁽¹⁾ Including external pilot connection, NC/NO pilot valves, gasket and O-rings

D = Butt-weld DIN

A = Butt-weld ANSI

SOC = Socket weld ANSI

SD = Solder DIN

SA = Solder ANSI

Ordering complete factory assembled valve

Figure 26: ICLX 65

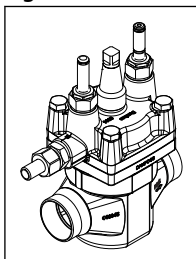

2-step solenoid valve, Type ICLX 32-150

Table 38: (body, function module / top cover)

Type ICLX 65						
Available connections						
65 D (2 1/2 in.)	65 A (2 1/2 in.)	80 D (3 in.)	80 A (3 in.)	67 SA (2 5/8 in.)	76 SD (3 in.)	65 SOC (2 1/2 in.)
027H6040	027H6041	027H8040	027H8042	(2)	(2)	027H6042

(2) Select from parts programme

ICLX 100/125/150 Complete factory assembled valve

Body, function module /topcover and NC / NO pilot valves

Figure 27: ICLX 100

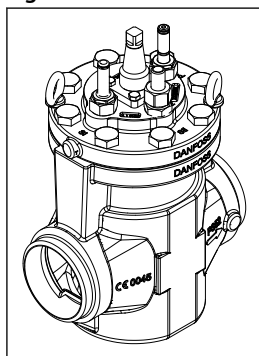

Figure 28: ICLX 125

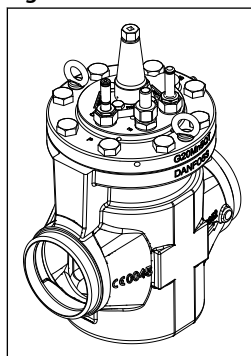

Figure 29: ICLX 150

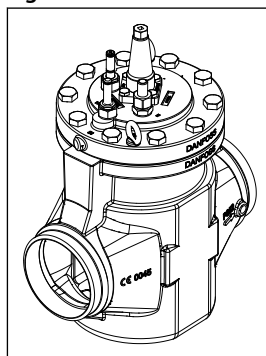

Table 39: ICLX 100

Type	Available connections	
ICLX 100	100 D (4 in.)	100 A (4 in.)
	027H7147	027H7148

Table 40: ICLX 125

Type	Available connections	
ICLX 125	125 D (5 in.)	125 A (5 in.)
	027H7157	027H7158

Table 41: ICLX 150

Type	Available connections	
ICLX 150	150 D (6 in.)	150 A (6 in.)
	027H7167	027H7168

Spare parts and accessories

Figure 30: ICV PM flanged valve housings

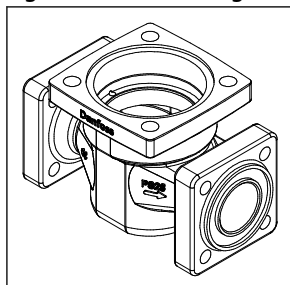

ICV PM flanged valve housings

ICV PM flanged valve housings can replace the PM valves on already installed refrigeration systems.

Pressure range

The ICV PM valve housing is designed for a max. working pressure of 28 bar g / 406 psig and therefore a suitable replacement for PM valves in the service market. They also offer the same drop-in dimensions as the PM valves.

Figure 31: Assembly

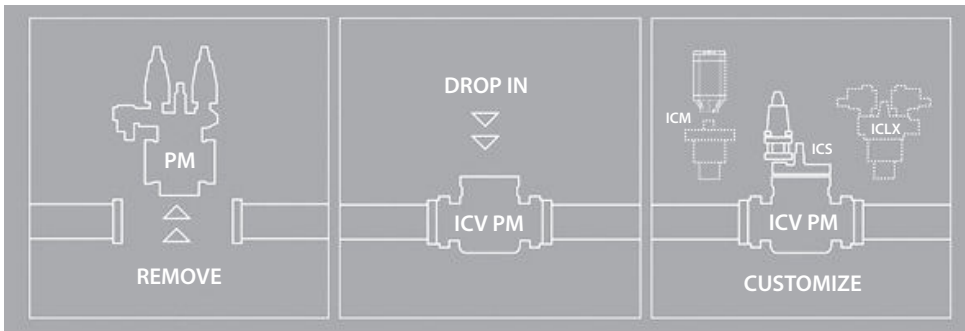

Table 42: ICV PM flanged valve housings

Description	Code no.
ICV 25 PM Valve housing	027H2119 ⁽¹⁾
ICV 32 PM Valve housing	027H3129 ⁽¹⁾
ICV 40 PM Valve housing	027H4128 ⁽¹⁾
ICV 50 PM Valve housing	027H5127 ⁽²⁾
ICV 65 PM Valve housing	027H6128 ⁽²⁾

⁽¹⁾ Includes ICV PM valve housing, flange gaskets and flange bolts.

⁽²⁾ Includes ICV PM valve housing, flange gaskets, flange bolts and flange nuts.

NOTE:

Function modules and top covers must be ordered separately (see the section **Ordering**).

Figure 32: ICV (H)A4A flanged valve housings

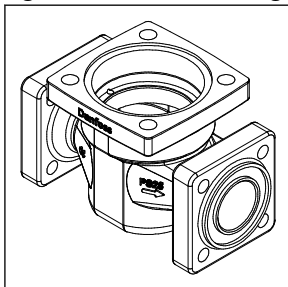

ICV (H)A4A flanged valve housings

ICV (H)A4A flanged valve housings can replace the (H)A4A valves on already installed refrigeration systems.

Pressure range

The ICV (H)A4A valve housing is designed for a max. working pressure of 28 bar g / 406 psig and therefore a suitable replacement for (H)A4A valves in the service market. They also offer the same drop-in dimensions as the (H)A4A valves.

Figure 33: Assembly

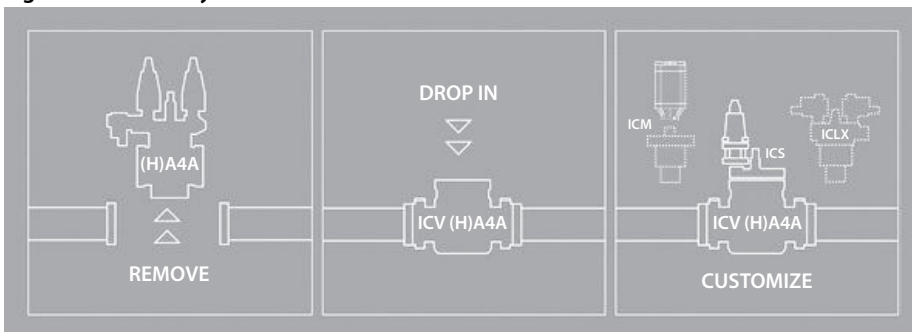

2-step solenoid valve, Type ICLX 32-150

Table 43: ICV (H)A4A flanged valve housings

Description	Code no.
ICV 25 (H)A4A Valve housing	027H2304 ⁽³⁾
ICV 32 A4A Valve housing	027H3130 ⁽³⁾
ICV 32 HA4A Valve housing	027H3131 ⁽³⁾
ICV 40 (H)A4A Valve housing	027H4129 ⁽³⁾
ICV 50 (H)A4A Valve housing	027H5128 ⁽⁴⁾
ICV 65 (H)A4A Valve housing	027H6129 ⁽⁴⁾

⁽³⁾ Includes ICV (H)A4A valve housing, flange gaskets and flange bolts.

⁽⁴⁾ Includes ICV (H)A4A valve housing, flange gaskets, flange bolts and flange nuts.

NOTE:

Function modules and top covers must be ordered separately (see the section [Ordering](#)).

Figure 34: Cap including gasket

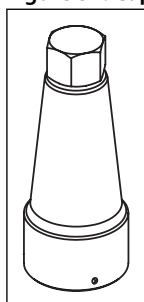

Table 44: Cap including gasket

Valve size	Code number
ICLX 32 – 40	148B3259
ICLX 50 – 100	148B4075
ICLX 125 – 150	148B4076

Figure 35: External pilot connection

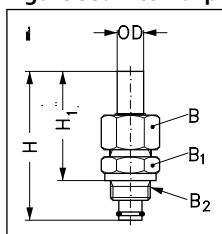

Table 45: External pilot connection

ICLX	Description	Code no.
32 – 80	External pilot connection (incl. damping orifice, D: 1.0 mm)	027F1048
32 – 80	External pilot connection (1/4" FPT) (incl. damping orifice, D: 1.0 mm)	027B2065
100 – 150	External pilot connection (incl. damping orifice, D: 1.8 mm)	027F1049
100 – 150	External pilot connection (1/4" FPT) (incl. damping orifice, D: 1.8 mm)	027B2066
32 – 150	Accessory bag with seal and O-ring for pilot valve	027F0666
32 – 80	Damping orifice for EVM. 10 pcs, (D: 1.0 mm)	027F0664
100 – 150	Damping orifice for EVM. 10 pcs, (D: 1.8 mm)	027F0176

NOTE:

A damping orifice should be installed if the pressure difference between the low and the high pressure side is more than 6 bar.

Table 46: Dimensions - see Fig. 35

Size	H	H ₁	øD	B	B ₁	B ₂
mm	90	66	18	NV 32	NV 32	M 24 × 1.5
in.	3.54	2.6	0.71			

Certificates, declarations, and approvals

The list contains all certificates, declarations, and approvals for this product type. Individual code number may have some or all of these approvals, and certain local approvals may not appear on the list.

Some approvals may change over time. You can check the most current status at danfoss.com or contact your local Danfoss representative if you have any questions.

The ICV valve concept is designed to fulfil global refrigeration requirements. The Factory assembled ICLX is CE and UL approved. For specific approval information, please contact Danfoss.

Table 47: Valid approvals

File name	Document type	Document topic	Approval authority
EAC RU Д-ДК.БЛ08.В.03639	EAC Declaration	Machinery & Equipment	EAC
EAC RU Д-ДК.БЛ08.В.00189_18	EAC Declaration	EMC	EAC
EAC RU Д-ДК.РА01.В.71727_20	EAC Declaration	PED	EAC
EAC RU С-ДК.БЛ08.В.01093_20	Pressure - Safety Certificate	PED	EAC
EU 033F0685.AK	EU Declaration	EMCD/PED	Danfoss
MD 033F0691.AE	Manufacturers Declaration	RoHS	Danfoss
TÜV 0045 202 1204 Z 00354 19 D 001(00)	Pressure - Safety Certificate	PED	TÜV
Manufacturers Declaration Danfoss 033F0474.AC	Manufacturers Declaration	ATEX	Danfoss
TSSA CRN.0C19205.2	Pressure - Safety Certificate	CRN	TSSA
RMRS 19.10325.266	Marine - Safety Certificate		RMRS
UL SA7200	Mechanical - Safety Certificate	UL	
GMPI TSX71002520151140	Manufacturing Permission	GMPI	
TSSA CRN.0C18990.5123467890YTN	Pressure - Safety Certificate	CRN	TSSA

Table 48: Compliance

	ICLX valves			
	Nominal bore	DN ≤ 25 (1 in.)	DN 32 – 65 (1 1/4 – 2 1/2 in.)	DN 80 – 150 (3 – 6 in.)
	Classified for	Fluid group I		
Category	Article 3, paragraph 3	II	III	

Online support

Danfoss offers a wide range of support along with our products, including digital product information, software, mobile apps, and expert guidance. See the possibilities below.

The Danfoss Product Store



The Danfoss Product Store is your one-stop shop for everything product related—no matter where you are in the world or what area of the cooling industry you work in. Get quick access to essential information like product specs, code numbers, technical documentation, certifications, accessories, and more.

Start browsing at store.danfoss.com.

Find technical documentation



Find the technical documentation you need to get your project up and running. Get direct access to our official collection of data sheets, certificates and declarations, manuals and guides, 3D models and drawings, case stories, brochures, and much more.

Start searching now at www.danfoss.com/en/service-and-support/documentation.

Get local information and support



Local Danfoss websites are the main sources for help and information about our company and products. Find product availability, get the latest regional news, or connect with a nearby expert—all in your own language.

Find your local Danfoss website here: www.danfoss.com/en/choose-region.

Danfoss Learning



Danfoss Learning is a free online learning platform. It features courses and materials specifically designed to help engineers, installers, service technicians, and wholesalers better understand the products, applications, industry topics, and trends that will help you do your job better.

Create your Danfoss Learning account for free at www.danfoss.com/en/service-and-support/learning.

Spare Parts



Get access to the Danfoss spare parts and service kit catalog right from your smartphone. The app contains a wide range of components for air conditioning and refrigeration applications, such as valves, strainers, pressure switches, and sensors.

Download the Spare Parts app for free at www.danfoss.com/en/service-and-support/downloads.

Coolselector®2 - find the best components for you HVAC/R system



Coolselector®2 makes it easy for engineers, consultants, and designers to find and order the best components for refrigeration and air conditioning systems. Run calculations based on your operating conditions and then choose the best setup for your system design.

Download Coolselector®2 for free at coolselector.danfoss.com.

Danfoss A/S

Climate Solutions • danfoss.com • +45 7488 2222

Any information, including, but not limited to information on selection of product, its application or use, product design, weight, dimensions, capacity or any other technical data in product manuals, catalogues descriptions, advertisements, etc. and whether made available in writing, orally, electronically, online or via download, shall be considered informative, and is only binding if and to the extent, explicit reference is made in a quotation or order confirmation. Danfoss cannot accept any responsibility for possible errors in catalogues, brochures, videos and other material. Danfoss reserves the right to alter its products without notice. This also applies to products ordered but not delivered provided that such alterations can be made without changes to form, fit or function of the product.

All trademarks in this material are property of Danfoss A/S or Danfoss group companies. Danfoss and the Danfoss logo are trademarks of Danfoss A/S. All rights reserved.