

iC7 Series Pre-charging Unit

for AFE and GC Modules

1 Overview

1.1 Pre-charging Unit

The pre-charging unit is used for pre-charging the system modules that are connected to the same DC bus. There are 3 electrical sizes, and an IEC and a UL variant of the unit.

- Pre-charging unit 10, IEC/UL
- Pre-charging unit 20, IEC/UL
- Pre-charging unit 30, IEC/UL

The pre-charging unit is available as an accessory.

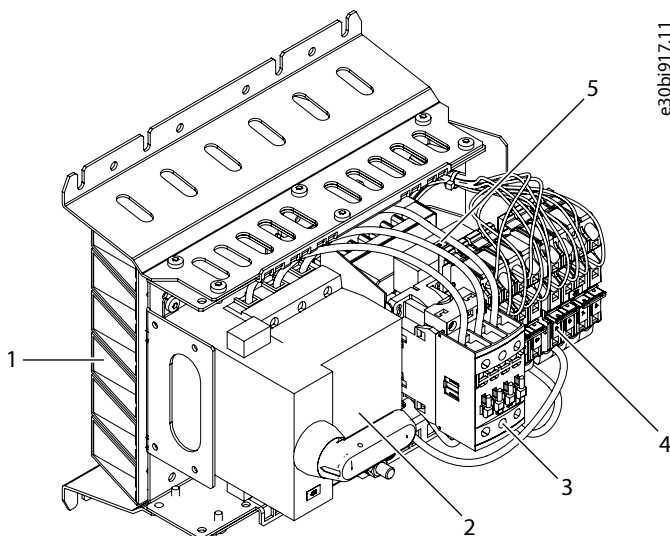

Figure 1: The Pre-charging Unit

1	Charging resistors	2	Fuse switch
3	Contactor	4	Terminal blocks
5	Rectifier and snubber capacitor		

2 Mechanical Installation

2.1 Safety Information

WARNING

DISCHARGE TIME

The drive contains DC-link capacitors, which can remain charged even when the drive is not powered. High voltage can be present even when the warning indicator lights are off. Failure to wait the specified time after power has been removed before performing service or repair work can result in death or serious injury.

- Stop the motor
- Disconnect all power sources, including permanent magnet type motors.
- Wait for capacitors to discharge fully. The discharge time is specified on the drive product label.
- Measure the voltage level to verify full discharge.

⚠ WARNING



SHOCK HAZARD FROM THE COMPONENTS

The components of the drive are live when the drive is connected to mains.

- Do not make changes in the AC drive when it is connected to mains.

2.2 Requirements for the Cabinet

The products that are described in this guide have the protection rating IP00/Open Type and do not have an enclosure. They must be installed in a cabinet or other enclosure that has a correct level of protection against the ambient conditions in the installation area. Make sure that the cabinet gives protection against water, humidity, dust, and other contaminations.

The cabinet must also be sufficiently strong to carry the weight of the system module and other devices.

The maximum temperature of the air inside the cabinet is +60 °C (+140 °F).

The protection rating of the cabinet must be at least IP21/UL Type 1. When preparing the installation, obey the local regulations.

2.3 Installing the Pre-charging Unit into the Cabinet

Install the pre-charging unit into the cabinet in a horizontal position.

1. Attach the pre-charging unit to the cabinet using the mounting holes.

Use M5 screws.

In industrial installations, use a minimum of 4 screws.

In marine installations, use 8 screws. To make the installation secure, use the outermost mounting holes.

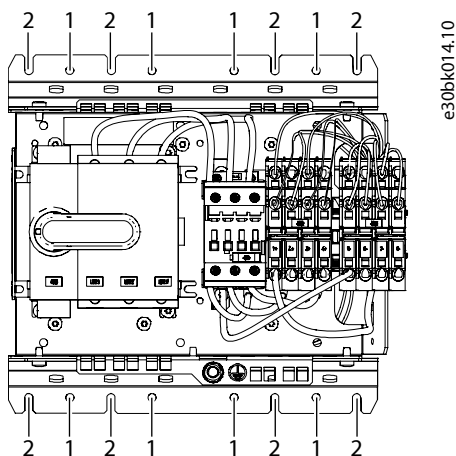

Figure 2: Mounting Holes of the Pre-charging Unit

1 Preferred mounting holes

2 Alternative mounting holes

2.4 Cooling Requirements

The maximum ambient temperature of the pre-charging unit is 60 °C (140 °F). The product is cooled with natural convection. Make sure that the installation position provides conditions for natural convection. A minimum of 50 mm (2 in) free space at top and bottom is necessary for sufficient cooling airflow.

CAUTION



BURN HAZARD

The pre-charging resistor is very hot during the pre-charging sequence and the following cooling down period.

- Do not install the pre-charging unit on a combustible surface.
- Do not touch when hot.

2.5 UL 98 Requirements

Minimum distances are required from the fuse switch of the pre-charging unit to the enclosure walls.

- 165 mm (6.50 in) from the top and bottom of the fuse switch terminals
- 13 mm (0.52 in) from the left side of the fuse switch

These distance requirements are for the size of the enclosure, not for electrical spacings.

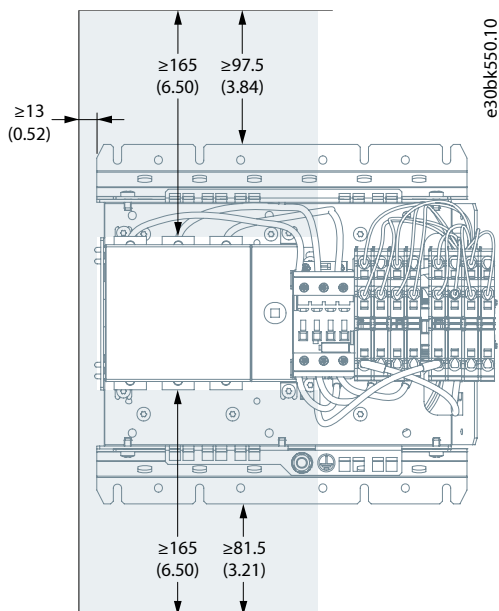
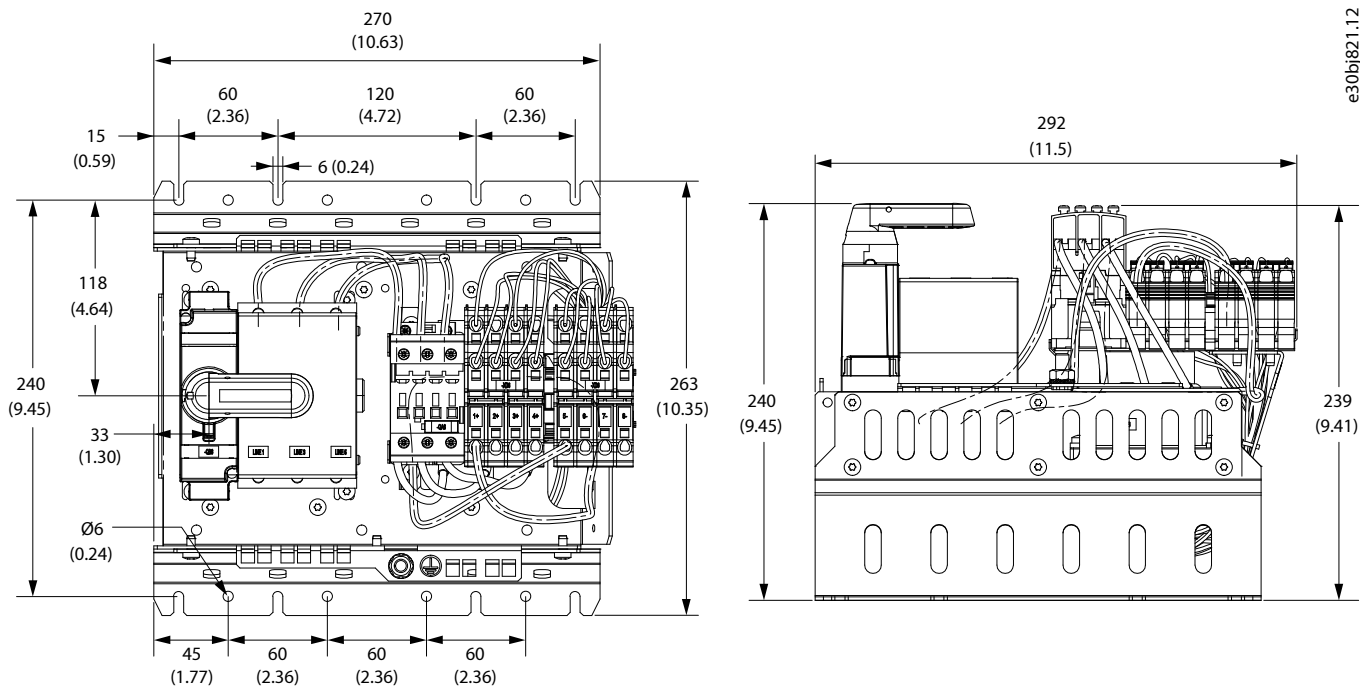

Figure 3: Keep-out-area Around the Pre-charge Unit 10–30 UL Types, UL 98

2.6 Dimensions of the Pre-charging Unit, IEC



e30bj821.12

Figure 4: Dimensions of the Pre-charging Unit in mm (in), IEC

2.7 Dimensions of the Pre-charging Unit, UL

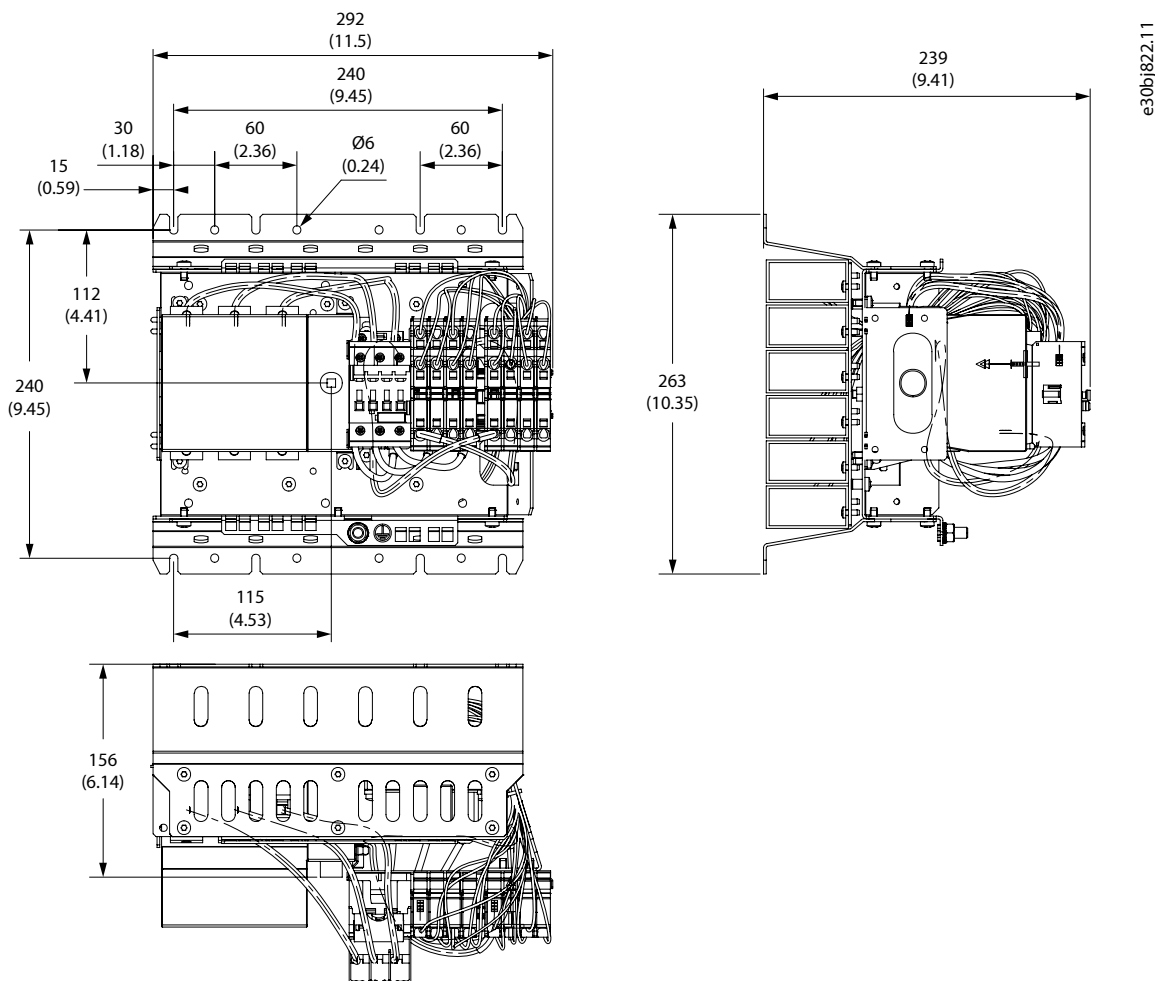

e30bj822.11

Figure 5: Dimensions of the Pre-charging Unit in mm (in), UL

3 Electrical Installation

3.1 Electrical Installation Safety

WARNING

OVERHEATED CABLES

Overheated cables are a fire hazard.

- Because of several possible cable installations and environmental conditions, it is important to consider local regulations and IEC/EN standards.

Route the main circuit and control circuit wires away from sharp edges, screw threads, burrs, fins, moving parts, drawers, and similar parts, which can abrade the wire insulation.

For the main circuit, use double-insulated wires or protect the wires with, for example, a protective sleeve or wrap to minimize the risk of short circuit. Maintain separation between the main and control circuit wires.

3.2 Cable Requirements

Table 1: Mains Terminals Line 1, Line 3, Line 5

Item	Value
Terminal type	Screw terminal
Tool	Flat head
Wire size (Cu)	4–10 mm ² (10–8 AWG), solid or stranded, with minimum insulation temperature rating of 75 °C.
Strip length	12 mm (0.47 in)
Torque per wire size	4–6 mm ² : 3 Nm 10 mm ² : 4 Nm 10 AWG: 30 in-lb 8 AWG: 35 in-lb

Table 2: DC Terminals DC+, DC

Item	Value
Terminal type	Spring terminal
Wire size (Cu)	4–10 mm ² (10–8 AWG), solid or stranded, with minimum insulation temperature rating of 75 °C.
Strip length	15 mm (0.59 in)

Table 3: Control Terminals A1, A2

Item	Value
Terminal type	Screw terminal
Tool	Pozidriv 2 or flat head 5.5 mm (0.22 in)
Wire size	1–2.5 mm ² (18–14 AWG)
Strip length	10 mm (0.39 in)
Torque	1.2 Nm (11 in-lb)

A PE conductor is required if the pre-charging unit is not fixed to a grounded conductive structural part of the drive enclosure.

Table 4: Grounding Terminal PE

Item	Value
Terminal type	Ring or fork terminal, size M8 Reference terminal type (UL): <ul style="list-style-type: none"> • P8-38R-Q (AWG 8, Panduit) • P10-38R-L (AWG 10, Panduit)
Wire size (Cu)	4–10 mm ² (10–8 AWG)

3.3 Fuses

Use only these fuse types in the fuse switch of the pre-charge unit.

Table 5: Fuse Specifications

Standard	Fuse I _n [A]	Fuse U _n [V AC]	Fuse type	Part number, Mersen	Part number, Eaton
IEC	40	690	NH gG size 000	H000GG69V40	40NHG000B-690
UL	40	600	Class J, Time-delay, 2–3/8 x 1–1/16 in (60x27 mm)	AJT40	LPJ-40SP

3.4 Terminals

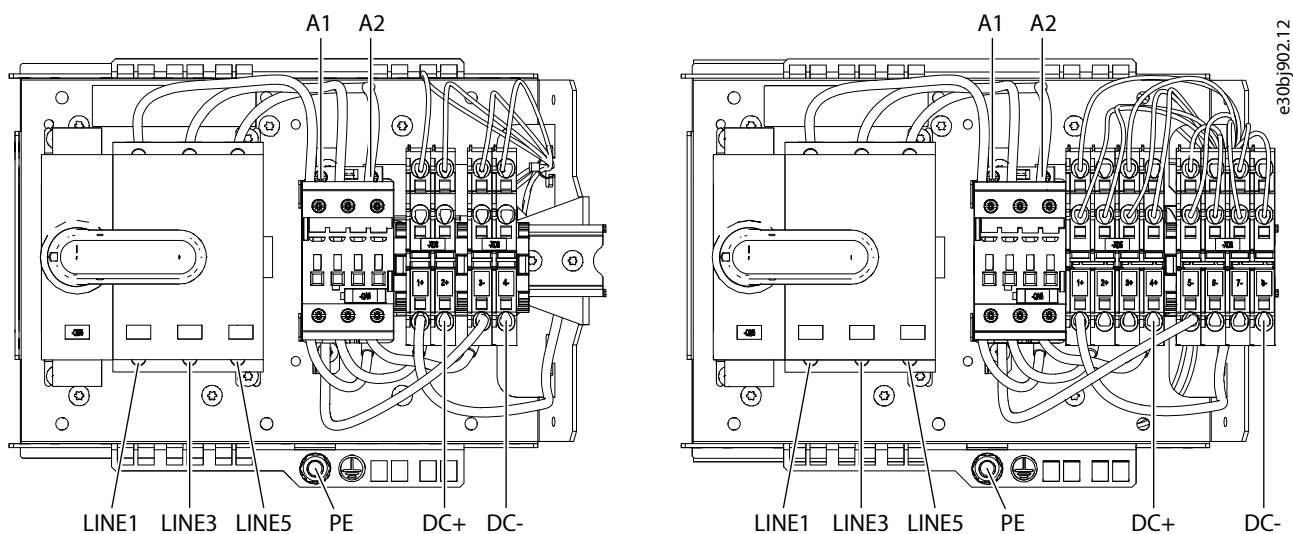

Figure 6: Terminals of the Pre-charging Unit

Left Pre-charging unit 10/20

Right Pre-charging unit 30

Table 6: Pre-charging Unit Terminal Descriptions

Terminal	Description
LINE1 LINE3 LINE5	AC-supply connection point for pre-charging circuit
DC+ DC-	Pre-charging circuit, DC terminal connection point
A1 A2	Pre-charging circuit, contactor coil terminal. Coil voltage range 100–250 V AC, 50/60 Hz.
PE	Grounding terminal for the pre-charging circuit

See the wiring diagrams in [3.6 Pre-charging Unit Wiring Diagram](#) and [3.7 Pre-charging Control Wiring Diagrams](#).

3.5 Installing the Power Cables

1. Attach the mains cable to the mains terminals Line 1, Line 3, and Line 5 of the pre-charging unit.
 - a. Attach the grounding conductor of the mains cable to the PE terminal of the pre-charging unit.

See the cable requirements in [3.2 Cable Requirements](#).

See the location of the mains terminals in [3.4 Terminals](#).

2. Attach the DC cable to the DC terminals DC+ and DC- of the pre-charging unit.

See the cable requirements in [3.2 Cable Requirements](#).

See the location of the DC terminals in [3.4 Terminals](#).

3.6 Pre-charging Unit Wiring Diagram

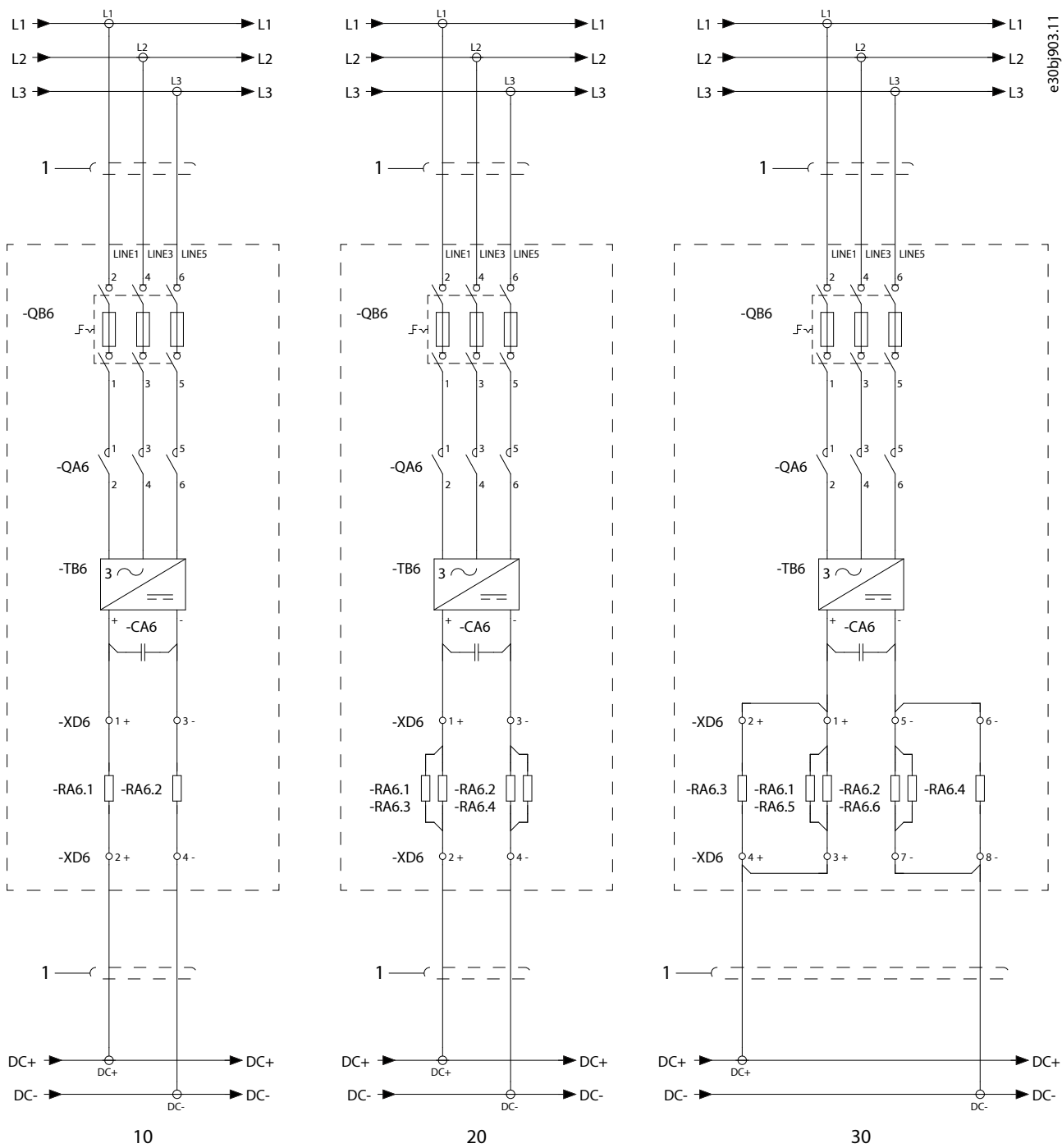

e30bj903.11

Figure 7: Main Circuits of the Pre-charging Units

1	Double-insulated cable	10	Pre-charging unit 10, IEC/UL
20	Pre-charging unit 20, IEC/UL	30	Pre-charging unit 30, IEC/UL

3.7 Pre-charging Control Wiring Diagrams

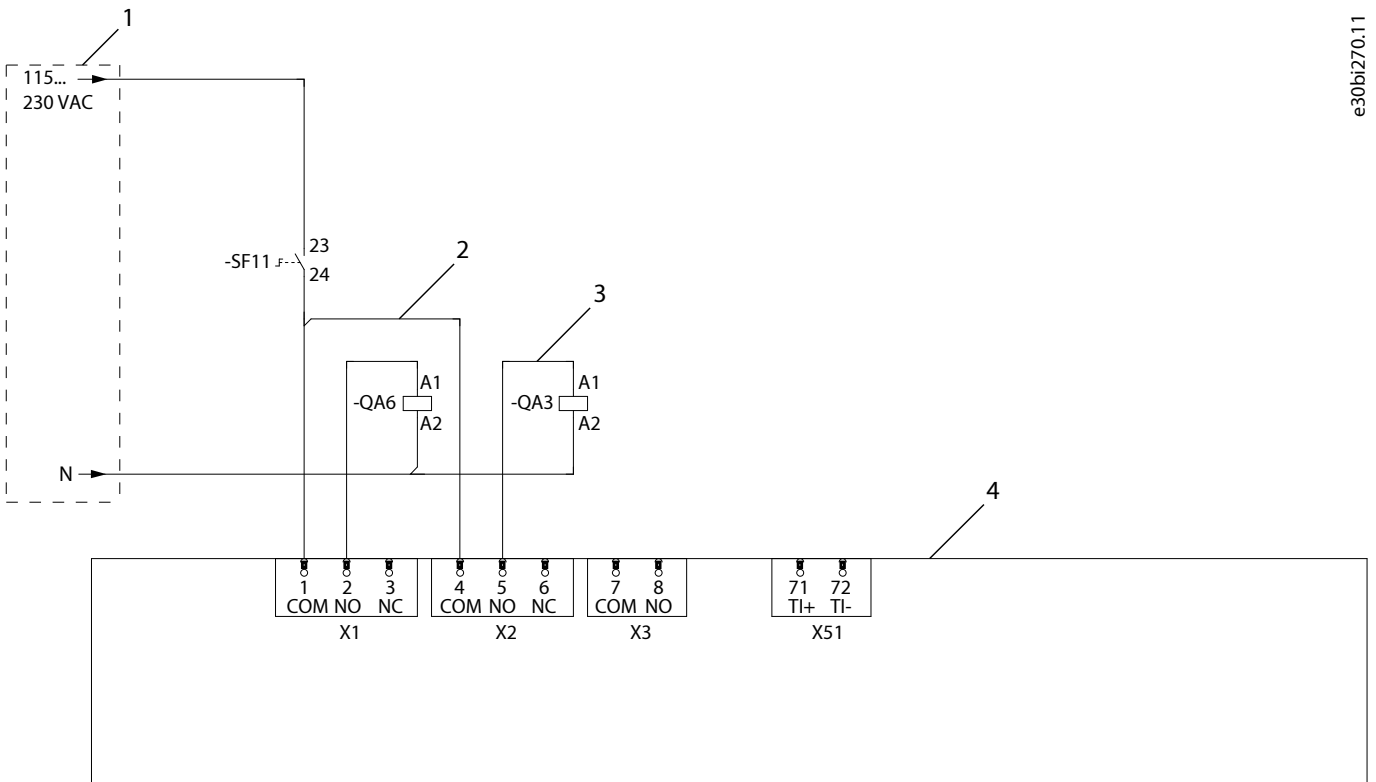

e30bi270.11

Figure 8: Pre-charging Control Wiring Diagram

1	Short-circuit protected	2	Pre-charging contactor control
3	Main input device control	4	Basic I/O of the control unit of the AFE module

Danfoss Drives Oy
Runsorintie 7
FIN-65380 Vaasa
drives.danfoss.com



.....
Any information, including, but not limited to information on selection of product, its application or use, product design, weight, dimensions, capacity or any other technical data in product manuals, catalog descriptions, advertisements, etc. and whether made available in writing, orally, electronically, online or via download, shall be considered informative, and is only binding if and to the extent, explicit reference is made in a quotation or order confirmation. Danfoss cannot accept any responsibility for possible errors in catalogs, brochures, videos and other material. Danfoss reserves the right to alter its products without notice. This also applies to products ordered but not delivered provided that such alterations can be made without changes to form, fit or function of the product. All trademarks in this material are property of Danfoss A/S or Danfoss group companies. Danfoss and the Danfoss logo are trademarks of Danfoss A/S. All rights reserved.
.....

