

User Manual

Remote Control MP08V Receiver



Revision history

Table of revisions

Date	Changed	Rev
January 2025	Updated safety and troubleshooting information	0301
March 2022	Safety warnings, technical description and installation updated	0201
August 2020	Corrections made to Pinout table on page 10	0102
January 2019	Rebranded to Danfoss Power Solutions	0101

Contents

Safety instructions

FCC rules.....	4
General safety.....	4
Safety warnings.....	5

Technical description

MP08 dimensions and identification.....	6
MP08A/MP08V detailed description.....	7

Installation

Receiver installation.....	8
Input and output configuration.....	9
Digital outputs.....	9
Analog outputs.....	10
MP08V stop category 3 PLe.....	10
Pinout.....	12

Troubleshooting

MP08 Receiver Faceplates.....	13
400-900MHz Receiver LED troubleshooting.....	13
2.4GHz Receiver LED troubleshooting.....	14

Safety instructions

FCC rules

This equipment has been tested and found to comply with the limits for a Class A digital device, pursuant to Part 15 of the FCC Rules.

Changes or modifications not expressly approved by the manufacturer can void the user's authority to operate the equipment.

To comply with FCC RF exposure compliance requirements, this device and its antenna must not be collocated with, or operating in conjunction with, any other antenna or transmitter, may not cause harmful interference, and must accept any interference received, including interference that may cause undesired operation.

The limits are designed to provide reasonable protection against harmful interference when the equipment is operated in a commercial environment. This equipment generates, uses, and can radiate radio frequency energy, and if not installed and used in accordance with the instruction manual, may cause harmful interference to radio communications.

Operation of this equipment in a residential area is likely to cause harmful interference in which case the user will be required to correct the interference at his own expense.

Warning

Le présent appareil est conforme aux CNR d'Industrie Canada applicables aux appareils radio exempts de licence. L'exploitation est autorisée aux deux conditions suivantes:

1. l'appareil ne doit pas produire de brouillage, et
 2. l'utilisateur de l'appareil doit accepter tout brouillage radioélectrique subi, même si le brouillage est susceptible d'en compromettre le fonctionnement.
-

MP08V General Safety

The following safety instructions must be read carefully to install and use the product properly, and to keep it in perfect working condition, and to reduce the risk of miss use.

- **Danfoss recommends the use of ESD PPEs (electrostatic discharge personal protection equipment).**
- Strictly adhere to the installation instructions contained in this document.
- Make sure that professional and competent personnel carry out the installation.
- Ensure that all on site and prevailing safety regulations are fully respected.
- The Electrical Installation where it may be connected, The receiver may be connected through an automatic magneto thermic switch (with omnipolar cut capacitance: F+N) and differential with characteristics according to the Low Voltage Recommendations.
- Make sure that this document is permanently available to the operator and maintenance personnel.
- Keep the transmitter out of reach of non-authorized personnel.
- Remove the transmitter key when the set is not in use.
- Check each working day the STOP button and other safety features. When in doubt, press the STOP button.
- Whenever several sets have been installed, make sure the transmitter is the right one. Identify the machine controlled on the label for this purpose on the transmitter or by using the display (in case it does have one).
- Service the equipment periodically.
- Avoid High Pressure water Spraying to Receivers while cleaning the machine
- When carrying out repairs, use spare parts supplied by Danfoss only.

Safety instructions

Warning

Potential damage to the operator or the product. Do not use this product on machines in potentially explosive atmospheres unless the model is ATEX/RATEX certified to work in such conditions.

MP08V Safety Warnings

Potential damage to operator and product.

Follow the guidelines below to reduce risk of injury to the operator and the product.

- Use the device with the manufacturer's battery and battery charger (if applicable).
- Only allow qualified personnel to operate the equipment.
- Always set the STOP button in the off position when not in use.
- Always press STOP before plugging in tether cable (if applicable).
- Remove the Tether connection on the transmitter First (if applicable).
- Do not operate product when visibility is limited.
- Make sure product is compatible with the machine.
- Avoid knocking or dropping the product.
- Do not use the product if a failure is detected.

Changes or modifications not approved by Danfoss can void the user's authority to operate this product.

Quick reference precautions

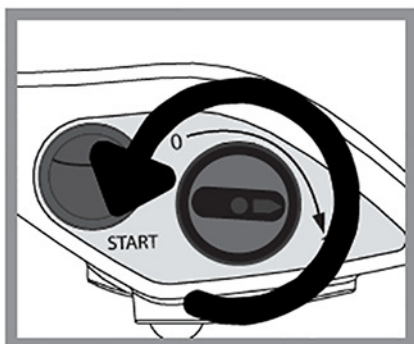

Remove the transmission key only when the set is not in use or to deny the access

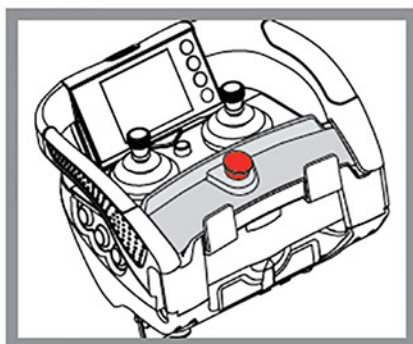

When in doubt, press the STOP button

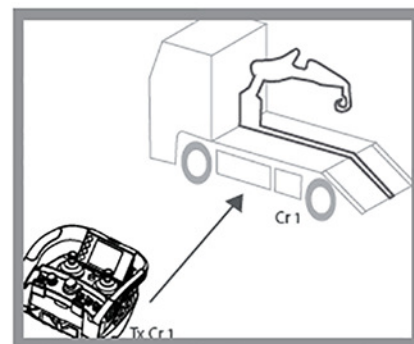

Make sure the transmitter works with the machine to be handled

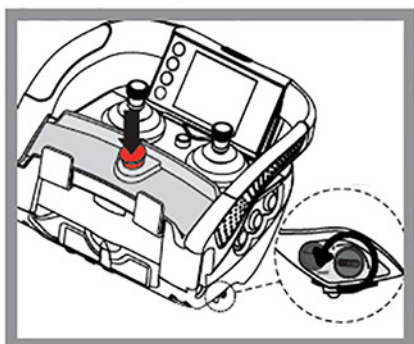

After use set the contact key and the STOP button

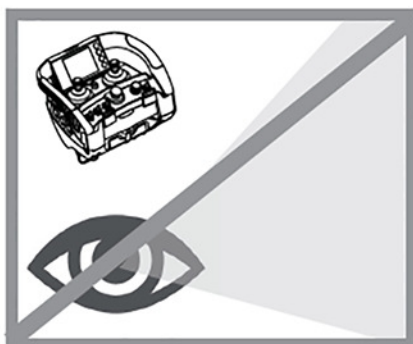

Do not use the set when visibility is limited

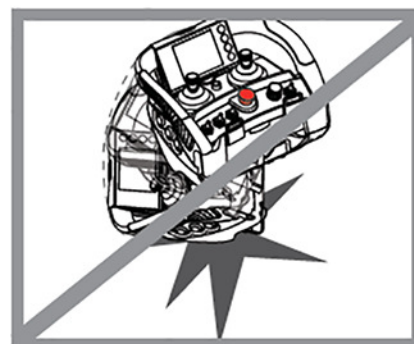

Avoid knocking or dropping the set

Technical description

MP08 dimensions and identification

Dimensions in mm

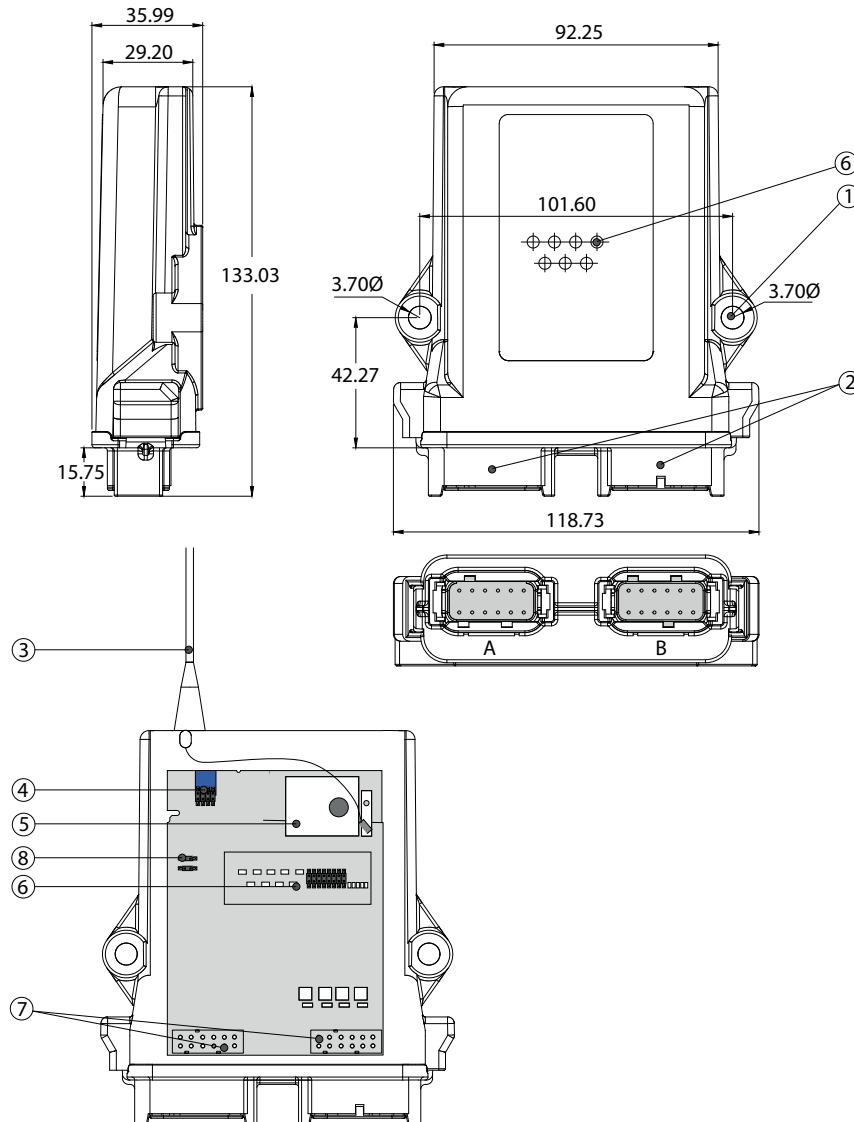

1. Fixing slots (fixed assembly or anti-vibration)
2. DEUTSCH connector
3. External antenna
4. Removable internal EEPROM
5. RF Module
6. External signaling LEDs
7. DEUTSCH connector pinout
8. Analog input configuration jumpers

Technical description

MP08A/MP08V detailed description

Technical data

Specification	MP08A	MP08V
Stop function (400-900 MHz)	Cat. 3-PLd	
Stop function (2.4 GHz)	Cat. 3-PLe	Cat. 4-PLe
Ingress protection	IP65/NEMA4	
Frequency band - ERP	433.050 to 434.040 MHz; ERP<1mW	
	434.040 to 434.790 MHz; ERP<10mW	
	869.700 to 870.000 MHz; ERP<5mW	
	902.000 to 928.000 MHz; ERP<1mW	
	2405MHz to 2475MHz; ERP 20dBm/100mW	
Range Line of sight (guaranteed)	100m	
AC power supply	N/A	
DC power supply	8-35 Vdc (200mA)	
Antenna	External/internal	
Removable EEPROM	Internal	
Signaling	External	
STOP Outputs (400 - 900MHz)	1 (2A)	
STOP Outputs (2.4GHz)	1 (2A)	
Start Output	N/A	
Safety Relay Output	N/A	
ON/OFF outputs	4 (2A per Output)	8 (2A per Output)
Proportional outputs	4 PWM (2.5A per Output)	4 Voltage (20mA per Output)
CAN Bus Protocols	N/A	CANopen
ON/OFF inputs	4	2
Proportional inputs	1	
Response Time	100ms	
Maximum Total output current	7.5A	
Operating temperature range	-20°C to 70°C (-4°F to 158°F)	
Storage Temperature Range (24h)	-25°C to 75°C (-13°F to 167°F)	
Storage Temperature Range (long periods)	-25°C to 55°C (-13°F to 131°F)	
Relative Humidity	max. 95% without condensation	
Weight	300g	
Dimensions (LxWxH mm)	117 x 133 x 36mm	
Tether Connection	N/A	
Associated transmitters (400 - 900MHz)	Ikargo1, Ikargo2, T70 1, T70 2, T70 1 HALL, T70 2 HALL, T70 1 ATEX, T70 2 ATEX, IK2, IK3, IK4	
Associated transmitters (2.4 GHz)	Ikompact, Ikore, IkoreB, Ikargo1, Ikargo2, IK1, IK2, IK3, IK4	

Installation

MP08V receiver installation

The below information describes hazards to be aware of during installation and steps to locate the receiver.

Risk of shock

Completely shut down the machine when installing the receiver.

Check the power supply and shut off the main switch to disconnect the interface cable between the receiver and the machine's electrical box.

1. Find an easily accessible and clear location with a direct vision between the receiver's antenna and the transmitter's working area.



2. Optional: If it is difficult to achieve direct vision between the receiver's antenna and the transmitter's working area, it is recommended to use an extended antenna in a clear location (only for models that allow an antenna).

In areas of high vibration, the use of Shock Absorbers is advised.

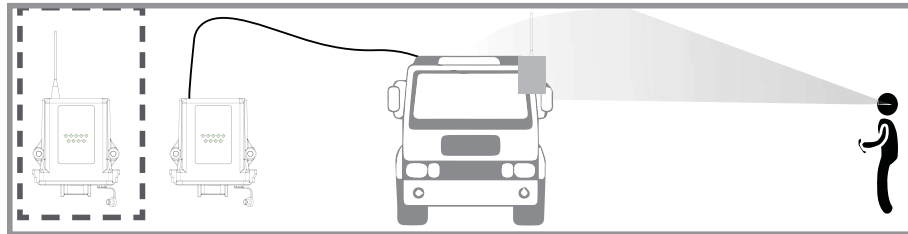

3. Proceed to connect the power supply. Use the connection block diagram provided with the system, where the correspondence between the transmitter maneuvers and the receiver's outputs are detailed.

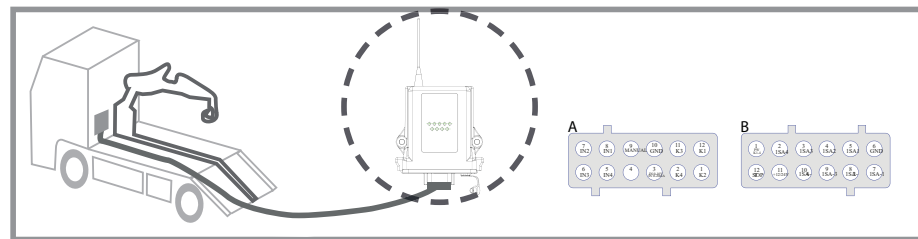

4. Check if the electrical installation and verify if there's an option to connect the neutral or the ground cable. In that case, don't forget to connect the ground cable.

The use of fireproof or flame retardant cables are recommended for the connection.

Installation

MP08 input and output configuration

This receiver has one analog input IN 0-10V (without isolation) or IN 0-20mA (without isolation). These inputs share the same hardware/pins and each one is selected by an internal jumper.

The two proportional inputs cannot live together at the same time.

The MP08 Receiver does have an current limitation of 7.5 Amps, however it does not include a Fuse. It is highly recommended to install an External fuse.

MP08V digital outputs

The digital outputs k1-k8 have a common contact at pin A1 of the connector. Maximum 2A per output. It is recommended to use K1 for by-pass valve.

DEUTSCH connector

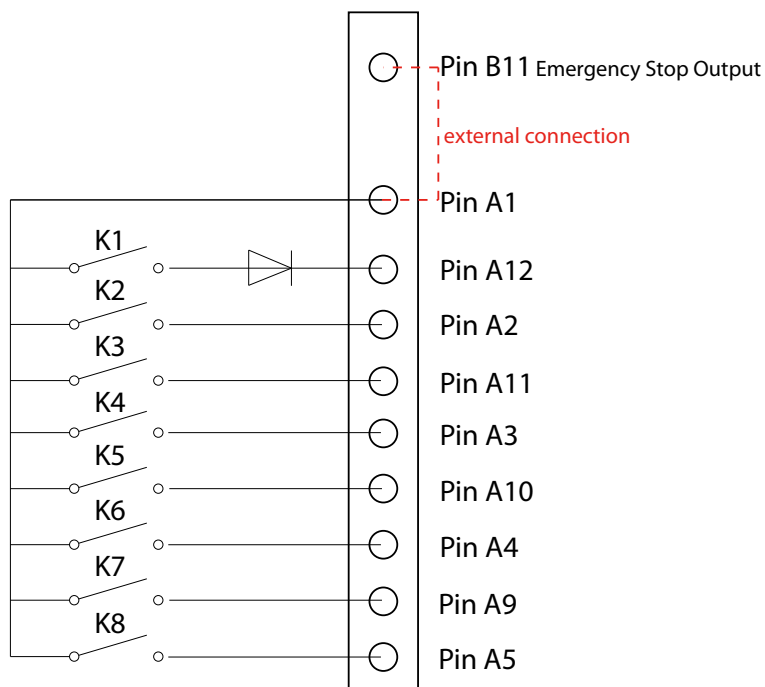

Installation

MP08V Proportional Voltage outputs

This receiver allows to choose the control voltage to set up the output power, throughout the selection of 1 switch.

Control voltage options: 0-5V, 0-10V, 0-Vcc

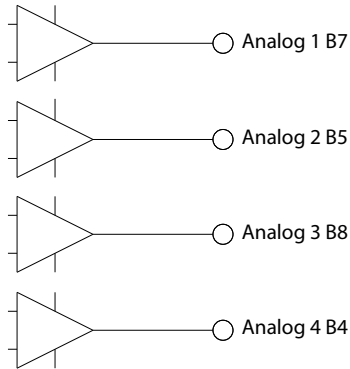

On the electronic board there are 4 Jumpers to determine Voltage outputs (I27).

Jumper	Legend	Jumper	Description
1	12/24	ON	Battery Voltage
2	0-10	ON	Maximum 10Vcc
3	0-5	ON	Maximum 5Vcc
4	Vcc/2	OFF	Rest Voltage Vcc/2

Only 2 Jumpers can be placed at the same time, only 1 voltage selection Jumper can be ON, and Vcc/2 to remove the half voltage selection. Default, only Jumper 1 is placed, being Battery level 12 or 24Vcc and Voltage in resting (neutral) position is Vcc/2.

MP08V stop category 3 PLe

Stop function is performed with 2 relays in series or parallel.

Pins B1 and B2 should not be connected directly to GND.

Series

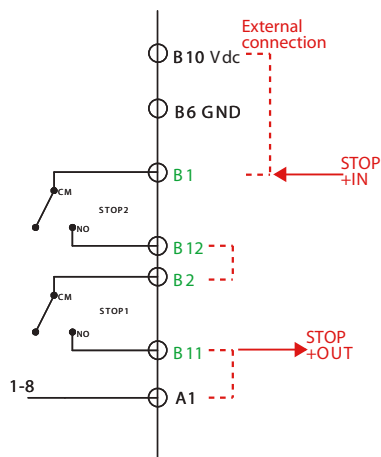

Installation

Parallel

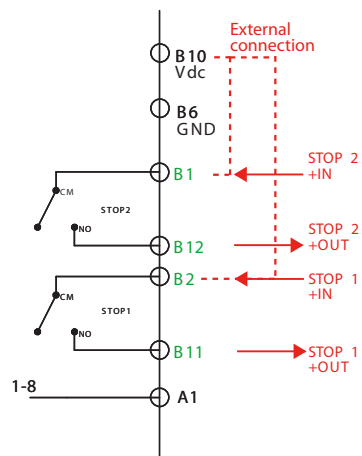

Installation

MP08V pinout

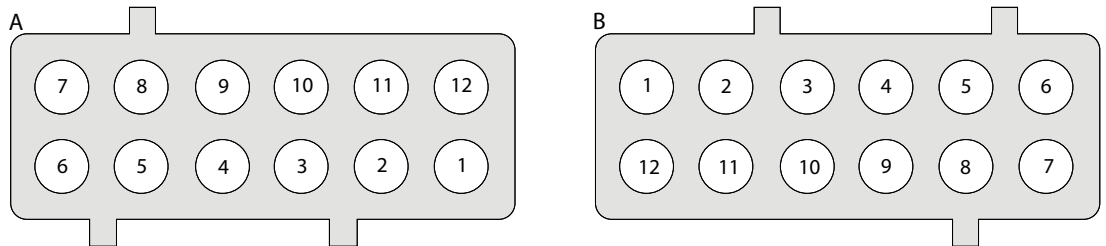

Pin A	Description	Pin B	Description
1	Power; K1-8	1	KSTOP2.1
2	K2	2	KSTOP1.1
3	K4	3	CANL
4	K6	4	SA4 (Voltage Output 4)
5	K8	5	SA2 (Voltage Output 2)
6	In 0-10V/In 4-20mA	6	GND
7	IN2	7	SA1 (Voltage Output 1)
8	IN1	8	SA3 (Voltage Output 3)
9	K7	9	CANH
10	K5	10	+12/24V
11	K3	11	KSTOP1.2
12	K1	12	KSTOP2.2

Troubleshooting

MP08 Receiver Faceplates

400 - 900 MHz and 2.4GHz Faceplates

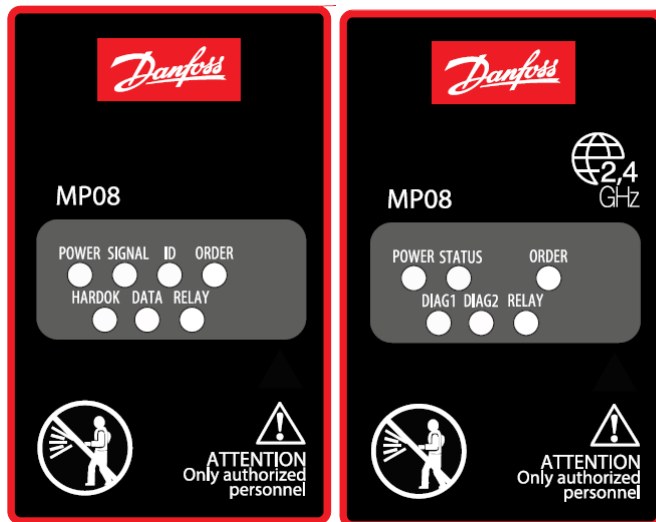

400-900MHz Receiver LED troubleshooting

The troubleshooting LEDs are located on the receiver board. Use the following table to identify faults and corrective action.

In order to reach the signaling, the receiver must be accessible, connected, and the screws located on the receiver lid must be unscrewed using the proper screw driver whenever the LEDs are not externally visible.

The LEDs on the receiver board are POWER, HARDOK, SIGNAL, DATA, ID, ORDER and RELAY.

Please do check the following website for further information:

<https://troubleshooting.dps-rct.com/en/customer-service-center>

LED	Characteristic	Description	Action
POWER	Green; pulsing	Receiver is starting up	Wait until start-up process is finished
HARDOK	Green; continuous	Receiver hardware OK	Operate
	Red; pulsing	EEPROM error; data corruption; CAN bus error (if CANERR activates)	Reprogram EEPROM
	Red; other	Electronic board hardware breakdown	Replace device
SIGNAL	LED off	No radio signal detected	-
	LED on + transmitter switched off	Radio channel occupied	Change transmitter's frequency channel
	LED on + DATA switched off	Radio channel occupied by non Danfoss system	Change transmitter's frequency channel
DATA	LED off + SINGAL LED on	Radio error	Replace radio
	Green; pulse	Receiving good frames	OK
ID	LED off + DATA LED on	No valid ID; Danfoss system nearby	If channel not occupied, check chosen ID in the transmitter or reset the receiver
	LED on + SIGNAL LED on + DATA LED on	Valid frames received from the transmitter; correct link	OK
RELAY	Green	STOP relay activated	-
ORDER	Green	LED ON Whenever any output is ON	-

Troubleshooting

LED	Characteristic	Description	Action
CANERR	Red slow pulses	CAN Error, physical Layer	Verify Connections
	Red double pulses	One expansion has Stopped working	Verify Expansion boards
	Red 4 pulses	A Transmitted CAN frame has been lost	N/A
	Red 5 pulses	A Received CAN Frame has been lost	N/A
	Red continuous	CAN Bus OFF	Verify CAN connections and Status.
CANRUN	Blinking Green	Pre operational Status	The Controller must set the CAN Receiver to operational Status
	Solid Green	Operational Status	OK

2.4GHz Receiver LED troubleshooting

The troubleshooting LEDs are located on the receiver board or accessible on the outside. Use the following table to identify faults and corrective action.

















In order to reach the internal signaling, the receiver must be accessible, connected and the screws located on the receiver lid must be unscrewed using the proper screw driver whenever the LEDs are not externally visible.

The LEDs on the receiver board are POWER, STATUS, DIAG1, DIAG2, ORDER, RELAY, CANERR and CANRUN in that order.









Please do check the following website for further information:

<https://troubleshooting.dps-rct.com/en/customer-service-center>

Troubleshooting

LED	Color and frequency	Pulse frequency	Description	Action
POWER	Green continuous		Switched ON if powered	Check power supply if LED is switched off.
STATUS	Blue fast pulses		System is starting; establishing connection with radio and EEPROM	Wait
	Blue continuous		Waiting for transmitter communication, coming from ACTIVE STOP	Release STOP button and press START on the transmitter.
	Blue slow pulses		Waiting for transmitter communication, coming from PASSIVE STOP	Press Start on the Transmitter
	Green continuous		Working	Operate
	Red slow pulses		EEPROM module missing or corrupt	Check EEPROM and reprogram if necessary
	Red double pulses		Radio communication error	Replace receiver
	Red triple pulses		Secondary micro error or error between micro communication	Replace receiver
	Red 4 pulses		ERROR	Check DIAG1 LED
	Red 5 pulses		After 15 sec Not all expansion boards have been initialized	Check CAN wiring and Configuration(EEP or Expansion ID#), Check Bus Termination.
	Red 1 Long + 1 short pulse		CAN Signature ERROR	Check Signature in Compliance Block and EEPROM are the same.
DIAG1	Orange slow pulses		Low tension in the receivers power supply	Supply the system with the correct voltage
	Orange double pulses		Hardware error	Replace receiver
	Orange triple pulses			
	Orange 4 pulses			
	Green slow pulses		Low link quality	N/A
	Green double pulses		Medium link quality	N/A
	Green triple pulses		High link quality	N/A
DIAG2	NOT USED	NOT USED	NOT USED	N/A

Troubleshooting

LED	Color and frequency	Pulse frequency	Description	Action
ORDER	Green continuous		LED ON Whenever any output is ON	N/A
RELAY	Green continuous		STOP relay activated	N/A
CANERR	Red slow pulses		CAN Error, physical Layer	Verify Connections
	Red double pulses		One expansion has Stopped working	Verify Expansion boards
	Red 4 pulses		A Transmitted CAN frame has been lost	N/A
	Red 5 pulses		A Received CAN Frame has been lost	N/A
	Red continuous		CAN Bus OFF	Verify CAN connections and Status.
CANRUN	Green fast pulses		Pre operational Status, Receiver waiting for the controller.	Controller must send the Operational code to the Receiver.
	Green continuous		Receiver connected to the CAN network and operational	N/A

Products we offer:

- Cylinders
- Electric converters, machines, and systems
- Electronic controls, HMI, and IoT
- Hoses and fittings
- Hydraulic power units and packaged systems
- Hydraulic valves
- Industrial clutches and brakes
- Motors
- PLUS+1® software
- Pumps
- Steering
- Transmissions

Danfoss Power Solutions designs and manufactures a complete range of engineered components and systems. From hydraulics and electrification to fluid conveyance, electronic controls, and software, our solutions are engineered with an uncompromising focus on quality, reliability, and safety.

Our innovative products makes increased productivity and reduced emissions a possibility, but it's our people who turn those possibilities into reality. Leveraging our unsurpassed application know-how, we partner with customers around the world to solve their greatest machine challenges. Our aspiration is to help our customers achieve their vision — and to earn our place as their preferred and trusted partner.

Go to www.danfoss.com or scan the QR code for further product information.

**Hydro-Gear**

www.hydro-gear.com

Daikin-Sauer-Danfoss

www.daikin-sauer-danfoss.com

**Danfoss
Power Solutions (US) Company**
2800 East 13th Street
Ames, IA 50010, USA
Phone: +1 515 239 6000

**Danfoss
Power Solutions GmbH & Co. OHG**
Krokamp 35
D-24539 Neumünster, Germany
Phone: +49 4321 871 0

**Danfoss
Power Solutions ApS**
Nordborgvej 81
DK-6430 Nordborg, Denmark
Phone: +45 7488 2222

**Danfoss
Power Solutions Trading
(Shanghai) Co., Ltd.**
Building #22, No. 1000 Jin Hai Rd
Jin Qiao, Pudong New District
Shanghai, China 201206
Phone: +86 21 2080 6201

Danfoss can accept no responsibility for possible errors in catalogues, brochures and other printed material. Danfoss reserves the right to alter its products without notice. This also applies to products already on order provided that such alterations can be made without subsequent changes being necessary in specifications already agreed. All trademarks in this material are property of the respective companies. Danfoss and the Danfoss logotype are trademarks of Danfoss A/S. All rights reserved.