

## Data Sheet

Hand operated regulating valve  
Type **REG-SA SS** and **REG-SB SS**

Assures favorable flow characteristics in harsh operating surroundings



In certain specific areas such as outdoor applications and corrosive atmospheres, such as coastal installations, there is a need for high surface protection to prevent failure due to corrosion.

Today's food safety standards often call for daily treatment with detergents to protect against bacteria growth, again producing a need for high surface protection.

REG-SA SS and REG-SB SS are angle-way and straight-way hand-operated regulating valves, which act as normal stop valves in closed position.

The valves are designed to meet the strict quality requirements on refrigerating installations specified by the international classification societies and are carefully designed to present favourable flow conditions and accurate linear characteristics.

The valves are equipped with vented cap and have internal backseating enabling the spindle seal to be replaced with the valve still under pressure.

## Features

- Applicable to HCFC, HFC, R717 (Ammonia), R744 (CO<sub>2</sub>), Propane, Butane, Iso-Butane and Ethane.
- R717 Heat Pump and Propylene applications with replaced O-ring.
- Designed to give favourable flow conditions.
- Internal backseating enables replacement of the spindle seal whilst the valve is active, i.e. under pressure
- Housing is made of special cold resistant stainless steel approved for low temperature operations.
- Easy to disassemble for inspection and service.
- Butt-weld DIN and ANSI connections.
- Max. operating pressure: 52 bar (754 psig)
- Temperature range: -60 °C / +150 °C (-76 °F / +302 °F)
- Compact and light valves for easy handling and installation
- Classification: DNV, CRN, BV, EAC etc. To get an updated list of certification on the products please contact your local Danfoss Sales Company.

## Media

### **Refrigerants**

#### **Refrigerants**

Applicable to HCFC, HFC, R717 (Ammonia), R744 (CO<sub>2</sub>), Propane, Butane, Iso-Butane and Ethane. R717 Heat Pump and Propylene applications with replaced O-ring.

For further information please contact your local Danfoss Sales Company.

### **New refrigerants**

Danfoss products are continually evaluated for use with new refrigerants depending on market requirements.

When a refrigerant is approved for use by Danfoss, it is added to the relevant portfolio, and the R number of the refrigerant (e.g. R513A) will be added to the technical data of the code number. Therefore, products for specific refrigerants are best checked at [store.danfoss.com/en/](https://store.danfoss.com/en/), or by contacting your local Danfoss representative.

## Product specification

### Pressure and temperature range

Figure 1: Pressure and temperature range graph

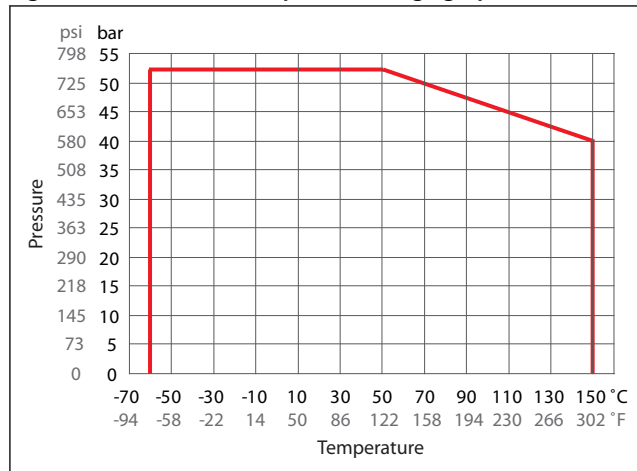

REG-SA SS/REG-SB SS DN 10 - DN 40

### Design

#### Housing

Made of stainless steel approved for low temperature operations.

#### The cone

The valves are available in two different versions – REG-SA SS with an A cone and REG-SB SS with a B cone. The A cone is designed for expansion lines, while the B cone is designed for regulating purposes e.g. liquid lines.

The valve cone is designed to ensure perfect regulation and provide an extensive regulating area. Irrespective of the refrigerant used, it is easy to obtain the correct capacity. A cone seal ring provides perfect sealing at a minimum closing momentum.

The valve cone can be turned on the spindle, thus there will be no friction between the cone and the seat when the valve is opened and closed.

Made of polished stainless steel, ideal for O-ring sealing. Furthermore, parts of the spindle are heat treated to obtain anti-abrasive/adhesive properties.

#### Packing gland - REG-SA SS and REG-SB SS

The stainless steel packing gland comprises a spring loaded seal packing gland which ensures a perfect tightness in the range: -60 °C / +150 °C (-76 °F / +302 °F).

The packing glands are equipped with a scraper ring to prevent penetration of dirt and ice into the packing gland.

For special and/or high demanding applications/conditions which run with high constant temperatures, it is recommended to replace the packing gland with "HL Packing Gland" as spare part. For more information, please, contact your local Danfoss sales representative.

#### Installation

Install the valve with the spindle up or in horizontal position. The flow must be directed towards the cone.

The valve is designed to withstand high internal pressure. However, the piping system in general should be designed to avoid liquid traps and reduce the risk of hydraulic pressure caused by thermal expansion.

For further information refer to installation guide for REG-SA SS and REG-SB SS.

Figure 2: Example of marking ring, REG-SA SS

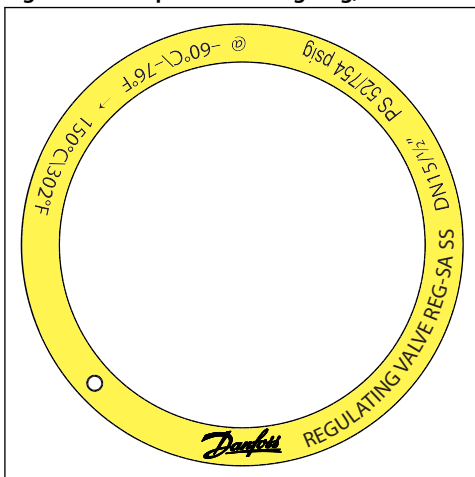

## Pressure and temperature data

Table 1: Pressure and temperature

Description	Values
Temperature range	-60 °C - +150 °C (-76 °F --+302°F)
Max working pressure	52 bar (754 psig)

## Flow coefficients

Flow coefficients for fully opened valves from  $k_v = 0.15$  to  $80 \text{ m}^3/\text{h}$  ( $C_v = 0.17$  to  $92.5 \text{ USgal}/\text{min}$ ).

## Connections

Available with the following connections:

Butt-weld DIN (EN 10220): DN 10 - 40 ( $3/8$  -  $1\frac{1}{2}$  in.)

Butt-weld ANSI (B 36.19M): DN 15 - 40 ( $1/2$  -  $1\frac{1}{2}$  in.)

Figure 3: DIN

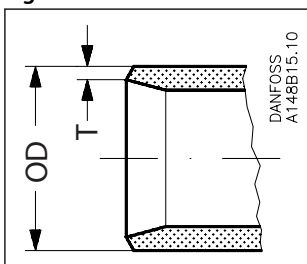

Table 2: Butt-weld DIN (EN 10220)

Size		OD	T
10	mm	17.2	2.3
$3/8$	in.	0.667	0.091
15	mm	21.3	2.3
$1/2$	in.	0.839	0.091
20	mm	26.9	2.3
$3/4$	in.	1.059	0.091
25	mm	33.7	2.6
1	in.	1.327	0.103
32	mm	42.4	2.6
$1\frac{1}{4}$	in.	1.669	0.102
40	mm	48.3	2.6
$1\frac{1}{2}$	in.	1.902	0.103

Figure 4: ANSI

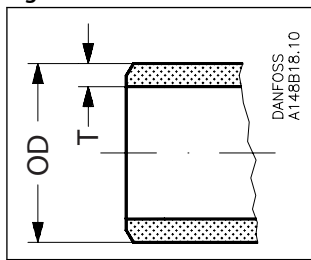

Table 3: Butt-weld ANSI (B 36.19M, SCHEDULE 40)

Size		OD	T
15	mm	21.3	2.8
½	in.	0.839	0.11
20	mm	26.9	2.9
¾	in.	1.06	0.11
25	mm	33.7	3.5
1	in.	1.33	0.14
32	mm	42.4	3.6
1¼	in.	1.67	0.14
40	mm	48.3	3.7
1½	in.	1.9	0.15

## Computation and selection

### Introduction

In refrigeration plants, regulating valves are primarily used in liquid lines in order to regulate the flow of refrigerant. The valves can, however, also be used as expansion valves. From a calculation point of view the two fields of application are very different.

Normal flow is the term used to describe the general case where the flow through the valve is proportional to the square root of the pressure drop across it and inversely proportional to the density of the refrigerant (Bernoullis equation).

Sizing regulating valve for liquid flow Liquid refrigerants: Use the liquid tables( [Figure 14: Calculation factor  \$C\_A\$](#)  and [Figure 15: Flow rate diagram](#)). For other refrigerants and brines, "Normal flow" (Turbulent flow); see below and use the flow coefficient tables ([Figure 6](#), [Figure 7](#) and [Figure 8](#)).

This relationship between mass flow, pressure drop and density satisfies the majority of all valve applications with refrigerants and brines.

Normal flow is characterised by turbulent flow through the valve without any phase change. The following capacity curves are based on the above mentioned assumption.

Application of the regulating valves outside the normal flow area will reduce the capacity of the valve considerably. In such cases it is recommended to use "DIRcalc™" (Danfoss Industrial Refrigeration calculation programme).

Figure 5: Location of valve in system (marked with grey)

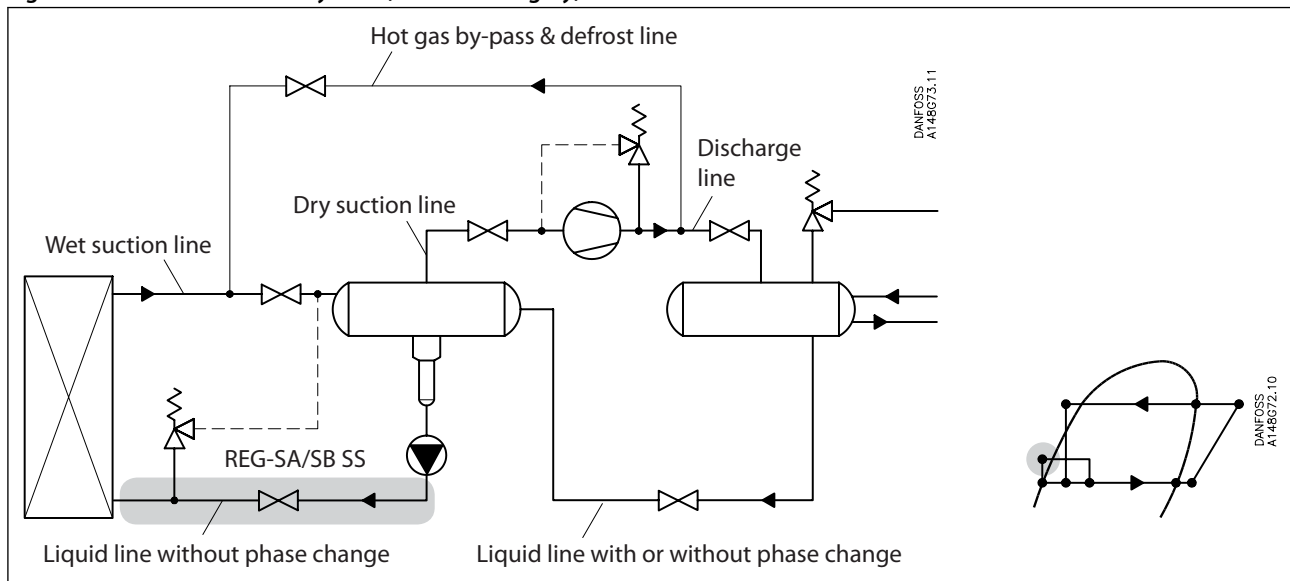

**SI-units**

Mass flow:

$$k_v = \frac{G}{\sqrt{\rho \times 1000 \times \Delta p}} = G \times C_A \text{ [m}^3\text{/h]}$$

Volume flow:

$$k_v = \frac{V}{\sqrt{\frac{1000 \times \Delta p}{\rho}}} \text{ [m}^3\text{/h]}$$

$k_v$	[m <sup>3</sup> /h]	Quantity [m <sup>3</sup> /h] of water flowing through a valve at a pressure loss of 1 bar (according to VDE/VDI Norm 2173).
$P_1$	[bar]	Pressure before the valve (upstream).
$P_2$	[bar]	Pressure after the valve (downstream).
$\Delta p$	[bar]	Actual pressure loss across the valve ( $P_1 - P_2$ ).
$G$	[kg/h]	Mass flow through the valve.
$V$	[m <sup>3</sup> /h]	Volume flow through the valve.
$\rho$	[kg/m <sup>3</sup> ]	Density of the refrigerant before the valve.
$C_A$		Calculation factor (See <a href="#">Figure 12: Calculation factor <math>C_A</math></a> ).

**Imperial units**

Mass flow:

$$C_v = \frac{0.95 \times G}{\sqrt{\rho \times \Delta p}} = 31.6 \times G \times C_A \text{ [USgal/min.]}$$

Volume flow:

$$C_v = \frac{0.127 \times V}{\sqrt{\frac{\Delta p}{\rho}}} \text{ [USgal/min.]}$$

$C_v$	[US gal/min]	Quantity [US gal/min] of water flowing through a valve at a pressure loss of 1 psi.
$P_1$	[psi]	Pressure before the valve (upstream).
$P_2$	[psi]	Pressure after the valve (downstream).
$\Delta p$	[psi]	Actual pressure loss across the valve ( $P_1 - P_2$ ).
$G$	[lb/min]	Mass flow through the valve.
$V$	[US gal/min]	Volume flow through the valve.
$\rho$	[lb/ft <sup>3</sup> ]	Density of the refrigerant before the valve.
$C_A$		Calculation factor (See <a href="#">Figure 12: Calculation factor <math>C_A</math></a> ).

Hand operated regulating valve, type REG-SA SS and REG-SB SS

Figure 6: REG-SA SS 10 and REG-SB SS 10

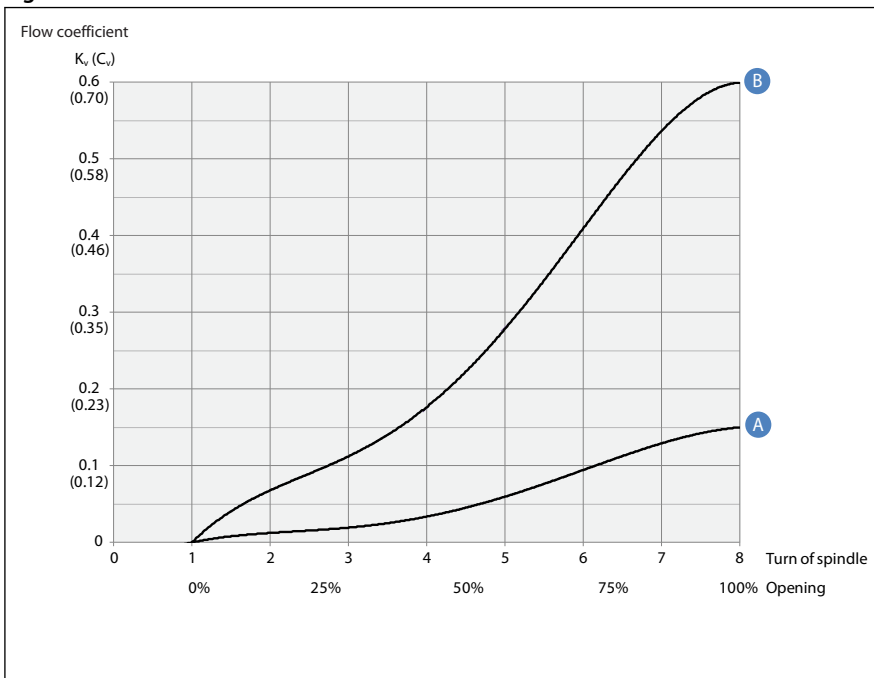

Figure 7: REG-SA SS 15-20 and REG-SB SS 15-20

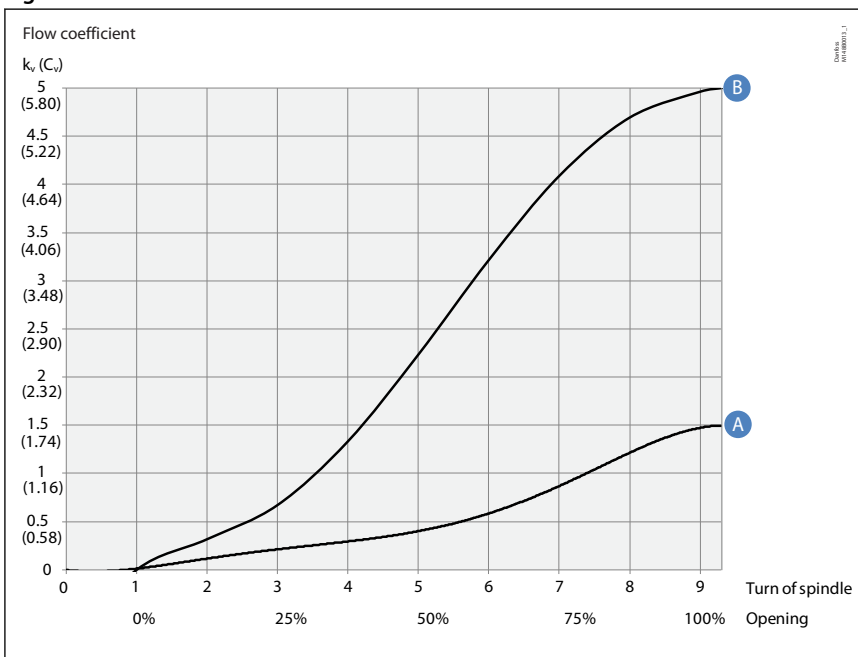
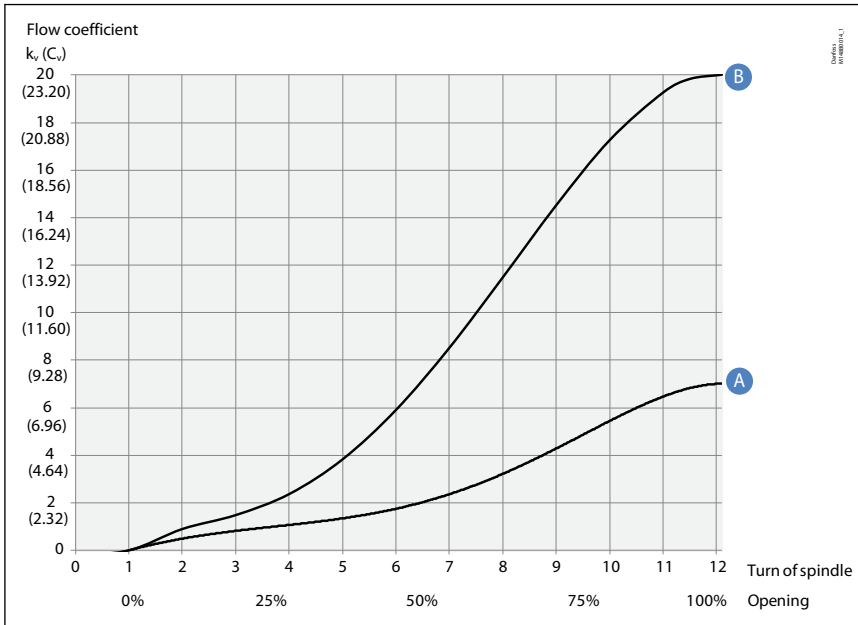

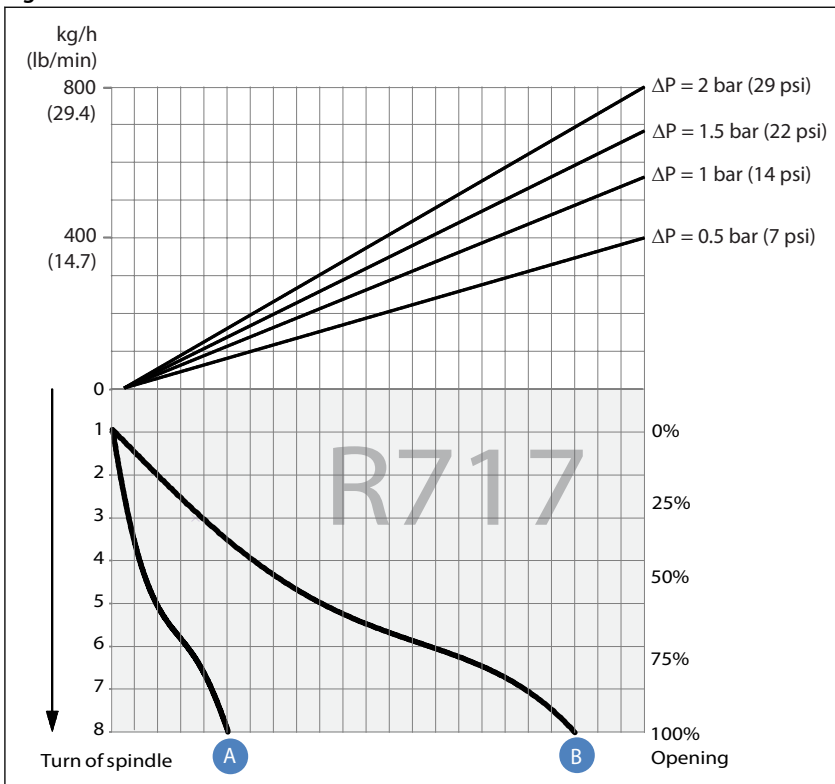

Figure 8: REG-SA SS 25-40 and REG-SB SS 25-40



Liquid R 717, density: 670 kg/m<sup>3</sup> [42 lb/ft<sup>3</sup>]

Figure 9: REG-SA SS 10 and REG-SB SS 10



Hand operated regulating valve, type REG-SA SS and REG-SB SS

Figure 10: REG-SA SS 15-20 and REG-SB SS 15-20

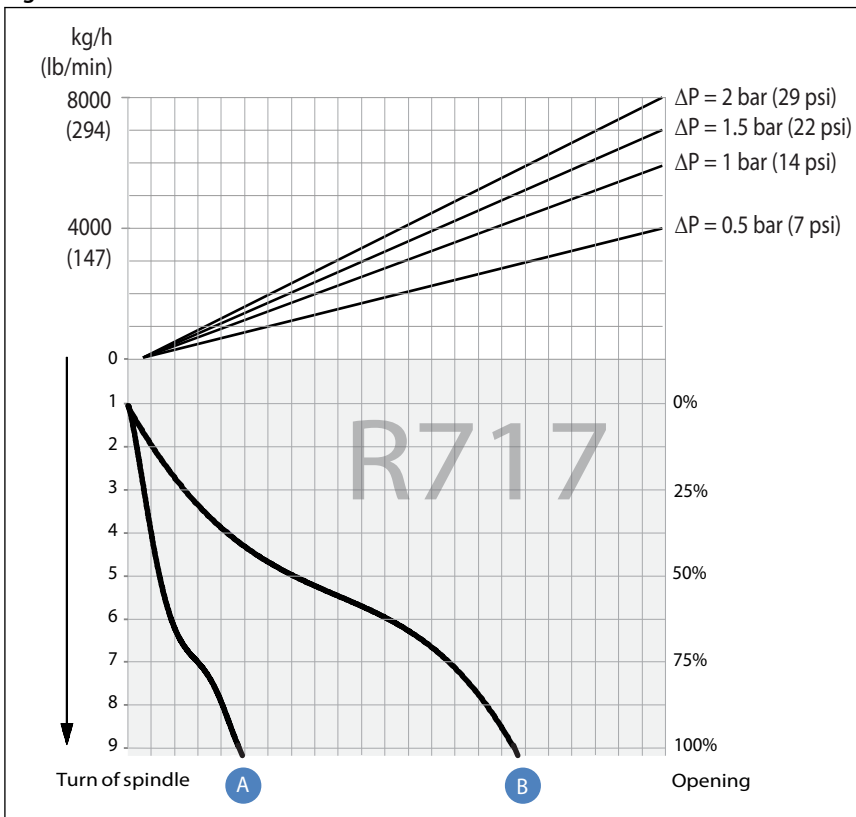

Figure 11: REG-SA SS 25-40 and REG-SB SS 25-40

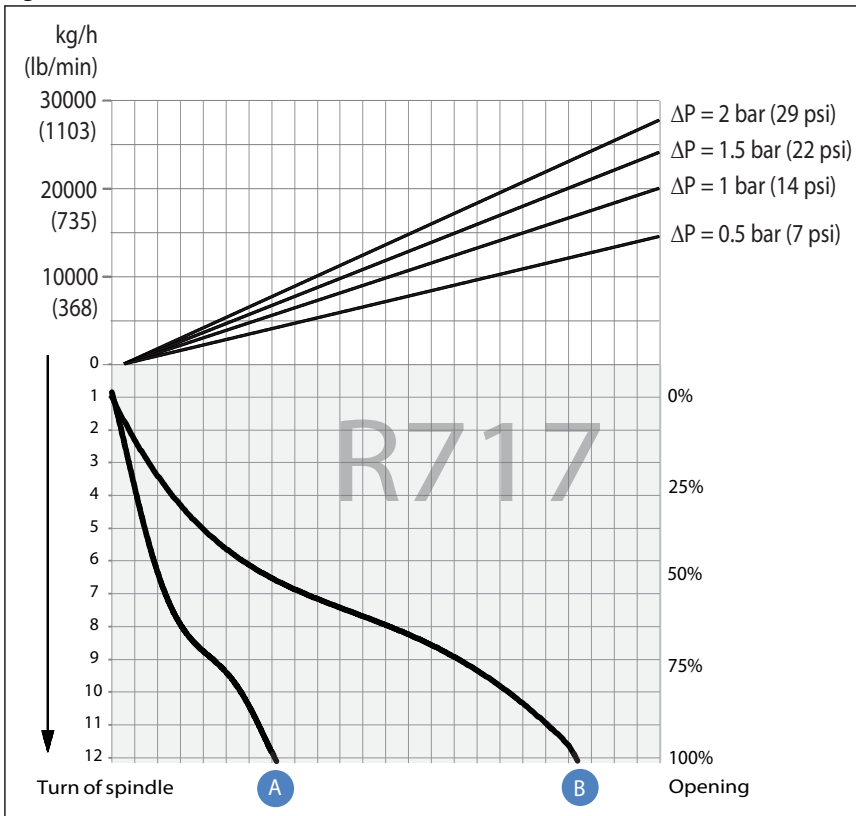
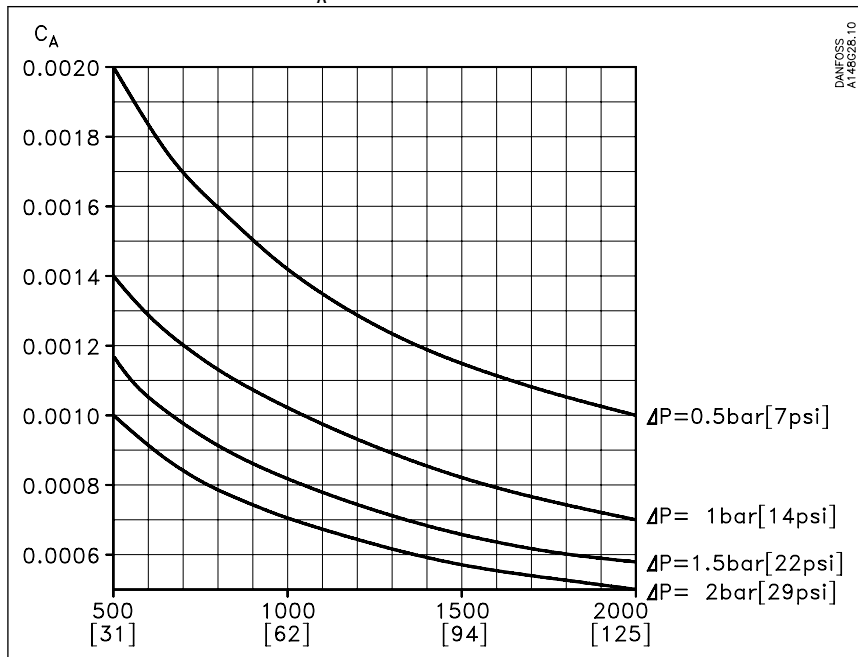

Figure 12: Calculation factor  $C_A$



**NOTE:**

For choice of valve size and connection see "Connections".

**Computation and selection Example 1.**

Refrigerant: R 717

Refrigerant flow: 2200 kg/h

Pressure drop:  $\Delta p = 0.5$  bar

The above mentioned example is illustrated on the following flow rate diagram and shows that REG-SB SS 15 and 20 with cone B can be used. The main rule is that nominal regulation range should be below 85% opening degree. If the arrowline is crossing 2 cone curves, the smaller cone should be selected if opening degree < 85%.

The example is only correct if the density of the refrigerant is approx. 670 (kg/m<sup>3</sup>), and there must be no build-up of flash gas in the valve.

Figure 13: Flow rate diagram

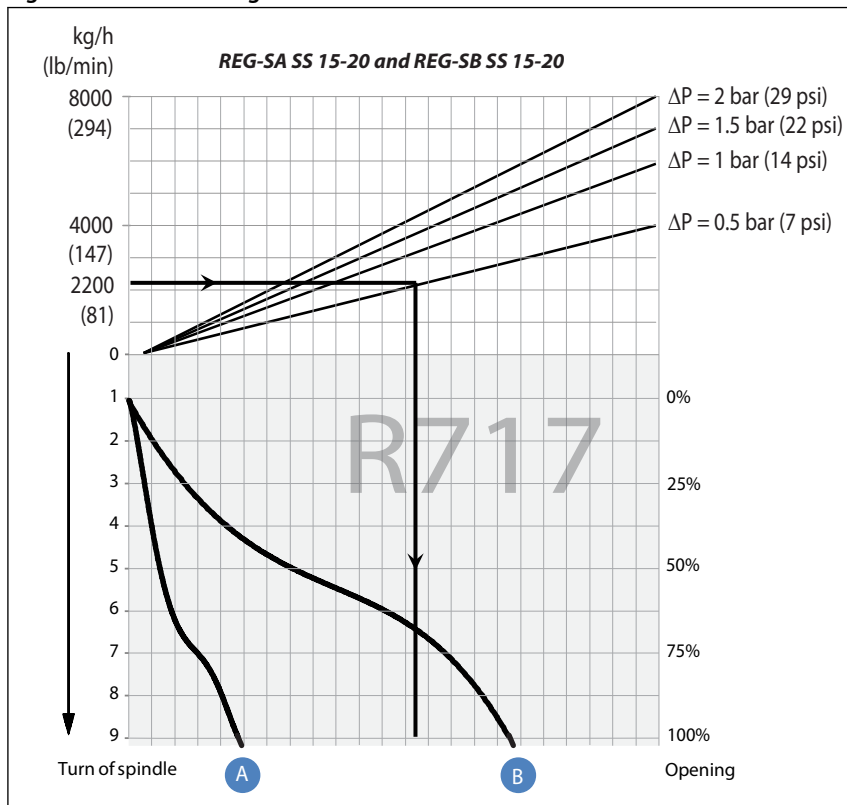

### Computation and selection Example 2.

Brine, density  $\rho$ : 1150 [kg/m<sup>3</sup>]

Brine flow G: 2,700 [kg/h]

Pressure drop  $\Delta p$ : 0.5 [bar]

In this example it is not possible to use the selection diagrams (Figure 9, Figure 10 and Figure 11) as the refrigerant in question is not included.

Use the curves of the  $k_v$ -values instead (Figure 6, Figure 7 and Figure 8) and calculate the required  $k_v$  by means of the formulas in the "Introduction" passage at the beginning of this chapter. Alternatively calculate the  $k_v$ -values by means of the calculation factor  $C_A$  (Figure 14: Calculation factor  $C_A$ ) and the flow rate diagram (in this example: Figure 15: Flow rate diagram) as per the following calculation example.

#### Calculation example:

Required  $k_v$ -value

$C_A = 0.00132$  (from Figure 15: Flow rate diagram)

$$k_v = C_A \times G$$

$$k_v = 0.00132 \times 2,700 \text{ [kg/h]}$$

$$= 3.56 \text{ [m}^3\text{/h]}$$

Figure 14: Calculation factor  $C_A$

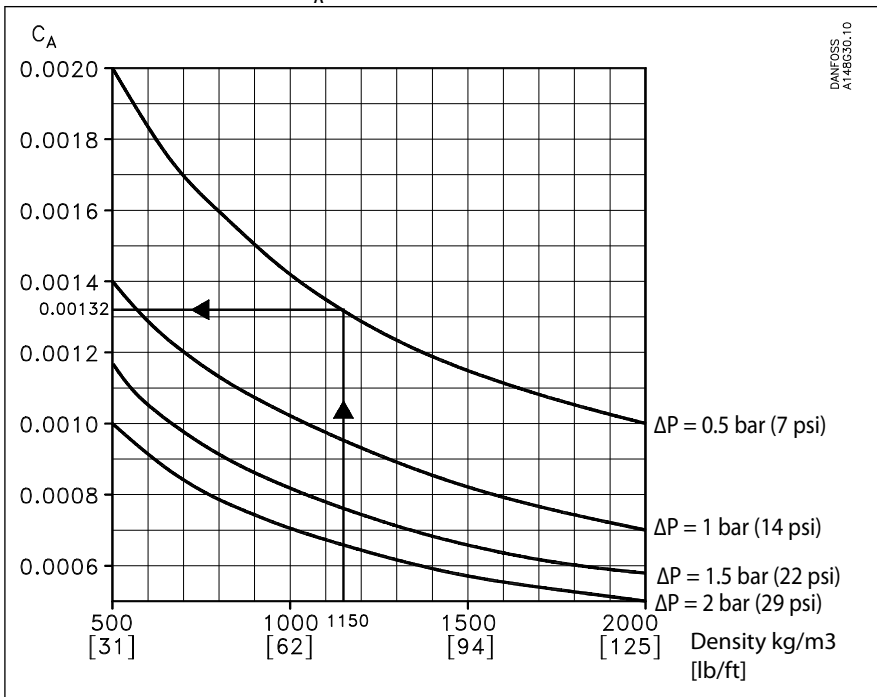
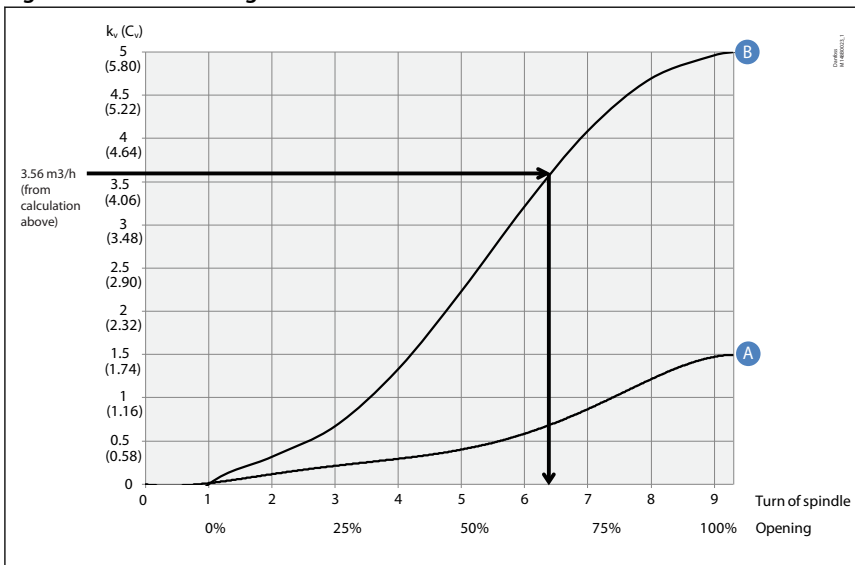

Figure 15: Flow rate diagram



**NOTE:**  
REG-SB SS 15 and REG-SB SS 20 with cone B can be used.

## Material specification

Figure 16: REG-SA SS and REG-SB SS 10 - 40

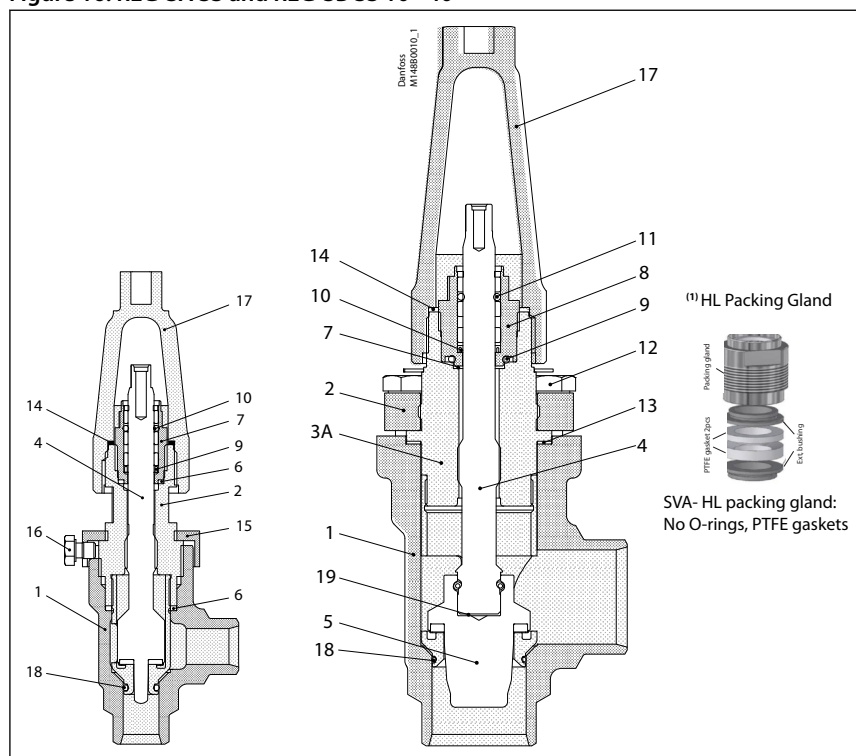

Table 4: Material and parts

No.	Part	Material	EN	ISO	ASTM
1	Housing	Stainless steel	GX5CrNi19-10 EN10213-4		AISI 304
2	Bonnet DN 10(3/8 in.) Bonnet, Flange DN 15-DN 40 (1/2 - 1 1/2 in)	Stainless steel	X5CrNi18-10 EN10088		AISI 304
3A	Bonnet, Insert DN 15-DN 40 (1/2 - 1 1/2 in)	Stainless steel	X8CrNiS18-9 DIN 17440		AISI 303
4	Spindle	Stainless steel	X8CrNiS18-9 DIN 17440	Type 17, 683/13	AISI 303
5	Cone	Steel			
6	Packing washer DN 10(3/8 in.)	Aluminium			
7	Packing washer DN 15-DN 40 (1/2 - 1 1/2 in)	Aluminium <sup>(1)</sup> None			
8	Packing gland	Stainless steel <sup>(1)</sup> (HL version) see pos. 8	X8CrNiS18-9 10088	Type 17, 683/13	AISI 303
9	O-ring	Chloroprene <sup>(1)</sup> None			
10	Spring loaded Teflon ring	PTFE <sup>(1)</sup> None			
11	O-ring	Chloroprene <sup>(1)</sup> None			
12	Bolts	Stainless steel	A2-70	A2-70	Type 308
13	Gasket	Fiber, non asbestos			
14	Gasket f. seal cap	Nylon			
15	Locking nut	Steel			
16	Screw	Steel			
17	Seal cap	Aluminium			
18	O-ring	Chloroprene <sup>(2)</sup>			
19	Disk spring	Steel			

## Hand operated regulating valve, type REG-SA SS and REG-SB SS

<sup>(1)</sup> REG SS with HL Packing gland only (see Table 16-19)

<sup>(2)</sup> Replace the O-ring with the replacement kit for R717 Heat Pump and R1270 Propylene applications.

### Dimensions and weights

REG-SA SS and REG-SB SS 10 - 40 in angleway version

Figure 17: REG-SA SS and REG-SB SS 10 - 40

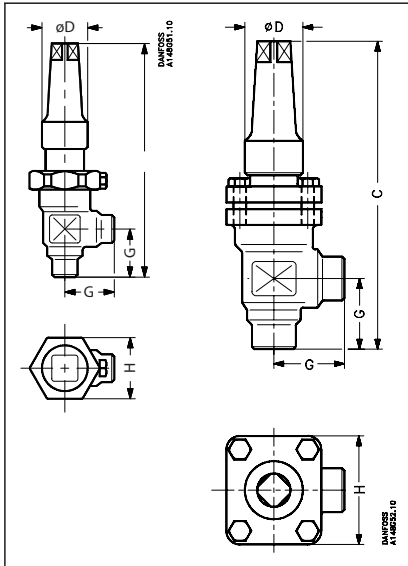

Table 5: REG-SA and REG-SB 10 - 65 in angleway version

Valve size		C	G	ØD	H	Weight
REG-SA/SB 10	mm	139	30	30	36	0.8 kg
REG-SA/SB (3/8)	in.	5.47	1.18	1.18	1.42	1.8 lb
REG-SA/SB 15-20	mm	182	45	38	60	1.4 kg
REG-SA/SB (1/2-3/4)	in.	7.17	1.77	1.50	2.36	3.1 lb
REG-SA/SB 25-40	mm	237	55	50	70	2.4 kg
REG-SA/SB (1-1/2)	in.	9.33	2.17	1.97	2.76	5.3 lb

#### NOTE:

Specified weights are approximate values only.

REG-SA SS and REG-SB SS 15 - 40 in straightway version

Figure 18: REG-SA SS and REG-SB SS 15 - 40

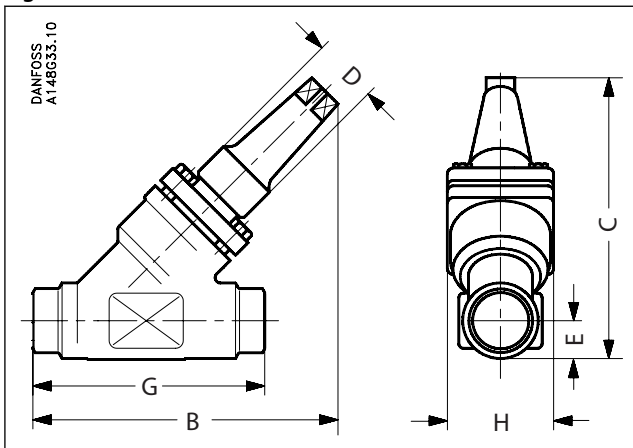

## Hand operated regulating valve, type REG-SA SS and REG-SB SS

**Table 6: Valve size and weight**

Valve size		C	B	E	G	ØD	H	Weight
<b>REG-SA SS/SB SS 15-20</b>	<b>mm</b>	145	155	20	120	38	60	2.0 kg
<b>REG-SA SS/SB SS (½-¾)</b>	<b>in.</b>	5.71	6.10	0.79	4.72	1.50	2.36	4.4 lb
<b>REG-SA SS/SB SS 25-40</b>	<b>mm</b>	200	215	26	155	50	70	3.0 kg
<b>REG-SA SS/SB SS (1-1½)</b>	<b>in.</b>	7.87	8.46	1.02	6.10	1.97	2.76	6.6 lb

**i NOTE:**

Specified weights are approximate values only.



## Ordering

### How to order

The table below is used to identify the valve required.

Please note that the type codes only serve to identify the valves, some of which may not form part of the standard product range. For further information please contact your local Danfoss Sales Company.

**Table 7: Type codes**

Valve type	REG SA SS REG-SB SS	Regulating Valves	Available connection types	
			D	A
Nominal size in mm (Valve size measured on the connection diameter)	10	DN 10	x	
	15	DN 15	x	x
	20	DN 20	x	x
	25	DN 25	x	x
	32	DN 32	x	x
	40	DN 40	x	x
Packing Gland	HL	HL Packing Gland		
Connections	D	Butt-weld connection: DIN EN 10220		
	A	Butt-weld connection: ANSI B 36.19M		
Valve housing	ANG	Angle flow		
	STR	Straight flow		
Cone A	<b>Size</b>	<b>Flow area [mm<sup>2</sup>]</b>		
	DN 10	3.02		
	DN 15	36.5		
	DN 20	36.5		
	DN 25	178		
	DN 32	178		
Cone B	<b>Size</b>	<b>Flow area [mm<sup>2</sup>]</b>		
	DN 10	16		
	DN 15	115		
	DN 20	115		
	DN 25	531		
	DN 32	531		

### Complete REG-SA SS (Cone type A)

Example:

REG-SA SS (Cone B) 15 DIN angleway = **148B5387**

**Table 8: Butt-weld DIN (EN 10220)**

mm	Size		Type	Code no.
	mm	in.		
<b>Angleway - REG-SA SS with cone type A</b>				
10		3/8	REG-SA SS 10 D ANG	148B5017
15		1/2	REG-SA SS 15 D ANG	148B5297
20		3/4	REG-SA SS 20 D ANG	148B5385
25		1	REG-SA SS 25 D ANG	148B5494
32		1 1/4	REG-SA SS 32 D ANG	148B5589
40		1 1/2	REG-SA SS 40 D ANG	148B5674

**Table 9: Butt-weld DIN (EN 10220)**

mm	Size		Type	Code no.
	mm	in.		
<b>Straightway - REG-SA SS with cone type A</b>				
15		1/2	REG-SA SS 15 D STR	148B5298
20		3/4	REG-SA SS 20 D STR	148B5386
25		1	REG-SA SS 25 D STR	148B5495
32		1 1/4	REG-SA SS 32 D STR	148B5590
40		1 1/2	REG-SA SS 40 D STR	148B5675

## Hand operated regulating valve, type REG-SA SS and REG-SB SS

**Table 10: Butt-weld ANSI (B 36.19M SCHEDULE 40)**

Size		Type	Code no.
mm	in.		
<b>Angleway - REG-SA SS with cone type A</b>			
15	½	REG-SA SS 15 A40 ANG	148B6482
25	1	REG-SA SS 25 A40 ANG	148B6483
32	1 ¼	REG-SA SS 32 A40 ANG	148B6484

**Table 11: Butt-weld ANSI (B 36.19M SCHEDULE 40)**

Size		Type	Code no.
mm	in.		
<b>Straightway - REG-SA SS with cone type A</b>			
15	½	REG-SA SS 15 A40 STR	148B5299
25	1	REG-SA SS 25 A40 STR	148B6485
32	1 ¼	REG-SA SS 32 A40 STR	148B6486

**D** = Butt-weld DIN

**A** = Butt-weld ANSI

**ANG** = Angleway

**STR** = Straightway

### **Complete REG-SB SS (Cone type B)**

**Table 12: Butt-weld DIN (EN 10220)**

Size		Type	Code no.
mm	in.		
<b>Angleway - REG-SB SS with cone type B</b>			
10	¾	REG-SB SS 10 D ANG	148B5018
15	½	REG-SB SS 15 D ANG	148B5387
20	¾	REG-SB SS 20 D ANG	148B5389
25	1	REG-SB SS 25 D ANG	148B5496
32	1 ¼	REG-SB SS 32 D ANG	148B5591
40	1 ½	REG-SB SS 40 D ANG	148B5676

**Table 13: Butt-weld DIN (EN 10220)**

Size		Type	Code no.
mm	in.		
<b>Straightway - REG-SB SS with cone type B</b>			
15	½	REG-SB SS 15 D STR	148B5388
20	¾	REG-SB SS 20 D STR	148B5390
25	1	REG-SB SS 25 D STR	148B5497
32	1 ¼	REG-SB SS 32 D STR	148B5592
40	1 ½	REG-SB SS 40 D STR	148B5677

**Table 14: Butt-weld ANSI (B 36.19M SCHEDULE 40)**

Size		Type	Code no.
mm	in.		
<b>Angleway - REG-SB SS with cone type B</b>			
20	¾	REG-SB SS 20 A 40 ANG	148B6487
40	1 ½	REG-SB SS 40 A 40 ANG	148B5686

**Table 15: Butt-weld ANSI (B 36.19M SCHEDULE 40)**

Size		Type	Code no.
mm	in.		
<b>Straightway - REG-SB SS with cone type B</b>			
20	¾	REG-SB SS 20 A 40 STR	148B6488
25	1	REG-SB SS 25 A 40 STR	148B6479
40	1 ½	REG-SB SS 40 A 40 STR	148B5685

## Hand operated regulating valve, type REG-SA SS and REG-SB SS

**D** = Butt-weld DIN

**A** = Butt-weld ANSI

**ANG** = Angleway

**STR** = Straightway

### **Complete REG-SA SS with HL Packing Gland (Cone type A)**

Table 16: Butt-weld DIN (EN 10220)

Size		Type	Code no.
mm	in.		
<b>Angleway - REG-SA SS with cone type A</b>			
15	½	REG-SA SS HL 15 D ANG VALVE CAP	148B5940
20	¾	REG-SA SS HL 20 D ANG VALVE CAP	148B5942
25	1	REG-SA SS HL 25 D ANG VALVE CAP	148B5944
32	1¼	REG-SA SS HL 32 D ANG VALVE CAP	148B5946
40	1½	REG-SA SS HL 40 D ANG VALVE CAP PS52	148B5956

Table 17: Butt-weld DIN (EN 10220)

Size		Type	Code no.
mm	in.		
<b>Straightway - REG-SA SS with cone type A</b>			
15	½	REG-SA SS HL 15 D STR VALVE CAP	148B5941
20	¾	REG-SA SS HL 20 D STR VALVE CAP	148B5943
25	1	REG-SA SS HL 25 D STR VALVE CAP	148B5945
32	1¼	REG-SA SS HL 32 D STR VALVE CAP	148B5947
40	1½	REG-SA SS HL 40 D STR VALVE CAP PS52	148B5957

### **Complete REG-SB SS with HL Packing Gland (Cone type B)**

Table 18: Butt-weld DIN (EN 10220)

Size		Type	Code no.
mm	in.		
<b>Angleway - REG-SB SS with cone type B</b>			
15	½	REG-SB SS HL 15 D ANG VALVE CAP	148B5948
20	¾	REG-SB SS HL 20 D ANG VALVE CAP	148B5950
25	1	REG-SB SS HL 25 D ANG VALVE CAP	148B5952
32	1¼	REG-SB SS HL 32 D ANG VALVE CAP	148B5954
40	1½	REG-SB SS HL 40 D ANG VALVE CAP PS52	148B5958

Table 19: Butt-weld DIN (EN 10220)

Size		Type	Code no.
mm	in.		
<b>Straightway - REG-SB SS with cone type B</b>			
15	½	REG-SB SS HL 15 D STR VALVE CAP	148B5949
20	¾	REG-SB SS HL 20 D STR VALVE CAP	148B5951
25	1	REG-SB SS HL 25 D STR VALVE CAP	148B5953
32	1¼	REG-SB SS HL 32 D STR VALVE CAP	148B5955
40	1½	REG-SB SS HL 40 D STR VALVE CAP PS52	148B5959

**D** = Butt-weld DIN

**A** = Butt-weld ANSI

**ANG** = Angleway

**STR** = Straightway

### **Replacement kit**

Replacement kit (O-ring replacement) for R717 Ammonia Heat Pump<sup>(1)</sup> and Propylene applications (including ID tag)

<sup>1</sup> Replacement kits for R717 Ammonia Heat Pump is applicable for continuous operating temperature between +100 °C - 150 °C (212 °F - 302 °F)

Table 20: O-ring kit

Size		O-ring kit for	
mm	in.	R717 Heat pump	R1270 Propylene
10	$\frac{3}{8}$	148B6084	148B6085
15	$\frac{1}{2}$	148B6070	148B6077
20	$\frac{3}{4}$		
25	1	148B6071	148B6078
32	$1\frac{1}{4}$		
40	$1\frac{1}{2}$		

## Certificates, declarations, and approvals

The list contains all certificates, declarations, and approvals for this product type. Individual code number may have some or all of these approvals, and certain local approvals may not appear on the list.

Some approvals may change over time. You can check the most current status at [danfoss.com](http://danfoss.com) or contact your local Danfoss representative if you have any questions.

**Table 21: Pressure Equipment Directive (PED)**

	REG-SA/SB SS valves are approved according to the European standard specified in the Pressure Equipment Directive and are CE marked.
-----------------------------------------------------------------------------------	--------------------------------------------------------------------------------------------------------------------------------------

**Table 22: Valves specifications**

REG-SA SS and REG-SB SS valves		
Nominal bore	DN = < 25 mm (1 in.)	DN32-40 mm (1¼ - 1½ in.)
Classified for	Fluid group I	
Catagory	Article 3, paragraph 3	II

**Table 23: Certificates and declarations**

File name	Document type	Document topic	Approval authority
03709-F0 BV	Marine - Safety Certificate	-	BV
033F0685.AK	EU Declaration	EMCD/PED	Danfoss
033F0691.AE	Manufacturers Declaration	RoHS	Danfoss

## Online support

Danfoss offers a wide range of support along with our products, including digital product information, software, mobile apps, and expert guidance. See the possibilities below.

### The Danfoss Product Store



The Danfoss Product Store is your one-stop shop for everything product related—no matter where you are in the world or what area of the cooling industry you work in. Get quick access to essential information like product specs, code numbers, technical documentation, certifications, accessories, and more.

Start browsing at [store.danfoss.com](https://store.danfoss.com).

### Find technical documentation



Find the technical documentation you need to get your project up and running. Get direct access to our official collection of data sheets, certificates and declarations, manuals and guides, 3D models and drawings, case stories, brochures, and much more.

Start searching now at [www.danfoss.com/en/service-and-support/documentation](https://www.danfoss.com/en/service-and-support/documentation).

### Danfoss Learning



Danfoss Learning is a free online learning platform. It features courses and materials specifically designed to help engineers, installers, service technicians, and wholesalers better understand the products, applications, industry topics, and trends that will help you do your job better.

Create your Danfoss Learning account for free at [www.danfoss.com/en/service-and-support/learning](https://www.danfoss.com/en/service-and-support/learning).

### Get local information and support



Local Danfoss websites are the main sources for help and information about our company and products. Find product availability, get the latest regional news, or connect with a nearby expert—all in your own language.

Find your local Danfoss website here: [www.danfoss.com/en/choose-region](https://www.danfoss.com/en/choose-region).

### Spare Parts



Get access to the Danfoss spare parts and service kit catalog right from your smartphone. The app contains a wide range of components for air conditioning and refrigeration applications, such as valves, strainers, pressure switches, and sensors.

Download the Spare Parts app for free at [www.danfoss.com/en/service-and-support/downloads](https://www.danfoss.com/en/service-and-support/downloads).

### Coolselector®2 - find the best components for you HVAC/R system



Coolselector®2 makes it easy for engineers, consultants, and designers to find and order the best components for refrigeration and air conditioning systems. Run calculations based on your operating conditions and then choose the best setup for your system design.

Download Coolselector®2 for free at [coolselector.danfoss.com](https://coolselector.danfoss.com).

### Danfoss A/S

Climate Solutions • [danfoss.com](https://danfoss.com) • +45 7488 2222

Any information, including, but not limited to information on selection of product, its application or use, product design, weight, dimensions, capacity or any other technical data in product manuals, catalogues descriptions, advertisements, etc. and whether made available in writing, orally, electronically, online or via download, shall be considered informative, and is only binding if and to the extent, explicit reference is made in a quotation or order confirmation. Danfoss cannot accept any responsibility for possible errors in catalogues, brochures, videos and other material. Danfoss reserves the right to alter its products without notice. This also applies to products ordered but not delivered provided that such alterations can be made without changes to form, fit or function of the product.

All trademarks in this material are property of Danfoss A/S or Danfoss group companies. Danfoss and the Danfoss logo are trademarks of Danfoss A/S. All rights reserved.