



## Model AB-QM Pressure Independent Balancing and Control Valve

### Actuator Submittal, Proportional AME 25 SU/SD Safety Function Actuator

DATE \_\_\_\_\_ SPEC. SECTION \_\_\_\_\_ PAGE \_\_\_\_\_ OF \_\_\_\_\_

<u>PROJECT</u>	<u>ARCHITECT/ENGINEER</u>	<u>APPROVALS</u>			
		<u>AGENCY</u>	<u>REPRESENTATIVE</u>	<u>DATE</u>	<u>NOTES</u>
		<b>ARCHITECT</b>			
		<b>ENGINEER</b>			
		<b>CONTRACTOR 1</b>			
		<b>CONTRACTOR 2</b>			
		<b>(OTHER)</b>			
<b>SUPPLIER</b>	<b>CONTRACTOR</b>	<i>NOTE COMMENT</i>			
<b>ORDER NO.</b>					



*Description*

The AME 25 SU/SD actuators are low voltage proportional actuators that are available with spring return function that are installed on the pressure independent control valve AB-QM. The spring return function of the AME provides a safety open or close of the valve in the event of power failure. Other features of the AME 25 SU/SD include:

- No tool requirement for installation
- Selectable linear or equal percentage actuator characteristic
- Force sensitive switch-off reducing overload to the actuator
- Automatic stem travel calibration

Model	Number	Unit Tag	Qty
AME 25 SU			
	- requires adapter 003Z0694		
AME 25 SD			
	- required spacer 003Z0694		

<b>Code No.</b>	AME 25 SU	AME 25 SD
	<b>082H3041</b>	<b>082G3038</b>
Power supply	24 VAC; +10%...-15%	
Power consumption	14 VA	
Frequency	50 Hz/60 Hz	
Control input	Proportional, 0(2) -10VDC, 0(4) -20mA	
Output signal	0 (2) - 10 VDC	
Close off force	101 lbf (450 N) Linear	
Max. actuator travel	15 mm	
Speed	15 s/mm	
Safety function speed	10 sec. from full open/close	
Max. medium temperature	302°F (150 °C)	
Ambient temperature	32 ... 131 °F (0 ... 55 °C)	
Degree of protection	IP 54, NEMA 2	
Weight	5 lb (2.3 kg)	
<b>CE</b> - marking in accordance with standards	Low Voltage Directive (LVD) 2006/95/EC: EN 60730-1, EN 60730-2-14 EMC Directive 2004/108/EC: EN 61000-6-2, EN 61000-6-3	

*Specification*

The motorized actuator shall be 24VAC powered and mount to the AB-QM valve body. The actuator shall be capable of calibrating its travel to the required stem travel of the valve and ensure that excessive overload travel of actuator does not occur. The operation of the actuator shall be determined based upon a proportional input signal of 0-10VDC, 2-10VDC, 0-20mA, or 4-20mA or 3-point floating input signal. The motorize actuator shall also have the ability of an output signal providing feedback regarding the actuator's position. The actuator shall also have the option of selectable valve flow adjustment in either a linear characteristic or equal percentage.

## Orientation

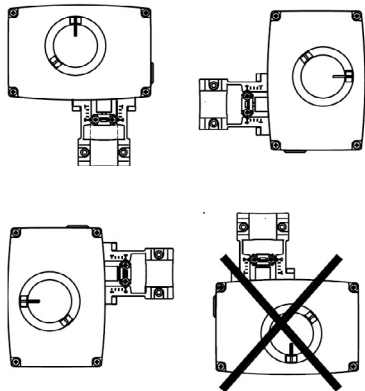

Installation of the valve with the actuator is allowed in a horizontal or pointing in an upwards position. The installation of the actuator pointing down is not allowed.

## DIP switches

- **SW 1:** Not used
- **SW 2:** Input signal range selector
  - 0-10 V / 2-10 V
  - 0-20 mA / 4-20 mA
- **SW 3:** Direct or Inverse reaction
  - Valve opens as input signal increases
  - Valve closes as input signal increases
- **SW 4:** Splitting the signal for actuator operation
- **SW 5:** Designation of actuator input signal operation
- **SW 6:** Input signal
  - 3-point Floating
  - Proportional
- **SW 7:** Actuator characteristic
  - Linear or equal-percentage
- **SW 8:** Not used
- **SW 9:** Reset learning of stem travel

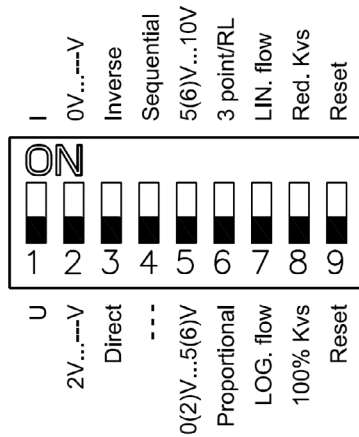

## Wiring

### Proportional

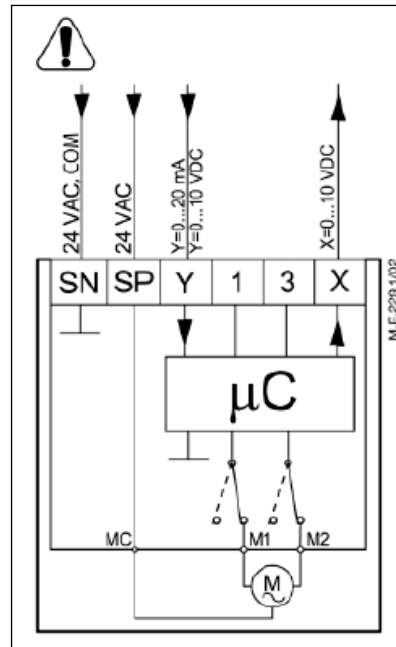

### 3-point Floating

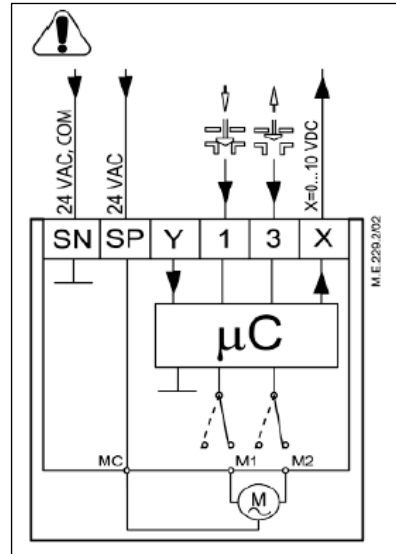

## Dimensions

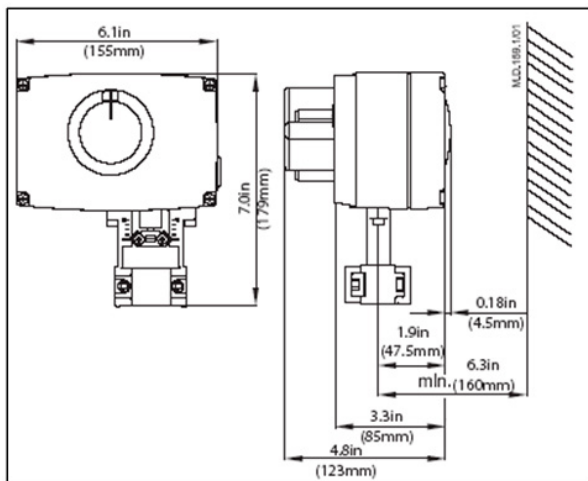

- SP** 24 VAC/DC ..... Power supply
- SN** Neutral ..... Common
- Y** 0-10 V ..... Input signal (2-10 V) 0-20 mA (4-20 mA)
- X** 0-10 V ..... Output signal (2-10 V)
- 1, 3** Override input signal (can not be used for 3-point control)