

## Fact sheet

# NovoCon® S

Linking hydronics to Building Automation to **save time and money** during construction and operation

## Highlights:

- Digital connectivity with BACnet and Modbus
- I/O capabilities and ChangeOver<sup>6</sup> connectivity
- Hydronic balancing performed electronically
- No manual adjustment required at the valve and actuator, everything is performed electronically via fieldbus
- Faster and reliable integration by using specialised commissioning tool
- Remote status and alarms help verify and identify hydronic and/or connectivity problems
- Building data available for trending and predictive maintenance

NovoCon® S is a smart digital actuator, specifically designed for use in combination with the Pressure Independent Balancing Control Valve type AB-QM in sizes from DN 10-32. The combination of NovoCon® S actuator with AB-QM valve is used to control water supply to fan coil units, radiant panels, induction units, heaters, small re-heaters, re-coolers, AHU's and other terminal units for zone control, in which hot/cold water is the controlled medium. NovoCon® S provides a transparent view of hydronic settings, hydronic balancing operational functionality, all via a fieldbus connection. Due to its accuracy, remote functionality and flow indication features, it accelerates the commissioning process, allows easy maintenance, improves indoor comfort, saves energy costs and enables energy monitoring at a room level without the need for a energy meter.



## General features:

- Remote commissioning
- Flow and energy indication
- High position accuracy
- LED bar displaying status & alarms
- Plug-in halogen free cables
- Auto MAC addressing for BACnet
- Auto baud rate detection
- Intrinsic alarm reporting for BACnet
- Valve blockage alarm
- Broken wire detection on analog control and ground signal
- NovoCon® S. There is only one device on the fieldbus representing status and alarms from both devices.
- BACnet MS/TP and Modbus RTU in the same product

## Together with AB-QM

The AB-QM valve and the NovoCon® S actuator unleash many innovative features and possibilities to utilise the building's BMS to its full potential. NovoCon® S adds value throughout a building's lifetime: during installation and commissioning, system integration, operation and maintenance. The digital actuator connects your heating or cooling system to the Building Management Systems (BMS) and adds new levels of hydronic balancing, control and remote functionality. This results in time savings during installation, remote commissioning and fine tuning, access to system data and remote identification of valve blockages or installation errors. In essence the digital actuator replaces multiple on-site visits with remote control of the system from the comfort of your office.

## 4-pipe change over application

Combined with the ChangeOver<sup>6</sup> the NovoCon® S offers a unique solution for controlling both the AB-QM valve and a 6-port motorised ball valve that performs a diverting function between two water circuits in 4-pipe changeover systems. The AB-QM balances the flow independently for heating and cooling and the NovoCon® S bus actuator controls the flow. Connectivity to the ChangeOver<sup>6</sup> valve are executed through the NovoCon® S. There is only one device on the fieldbus representing status and alarms from both devices.

## NovoCon® I/O functionality

NovoCon® I/O capabilities reduce the amount of controllers used, and through that, reduces the cost of the building automation system. NovoCon® S is able to connect to other devices, e.g. temperature sensors, room thermostats, window contacts, CO<sub>2</sub> sensors, humidity sensors, fan speed control, 0-10V actuator etc. Each NovoCon® S has an analog output, an analog input and two PT1000 (resistance) inputs.



## Application examples without local room controller

### Example 1:

NovoCon I/O is used to control ChangeOver<sup>6</sup> actuator position as well as read feedback of ChangeOver<sup>6</sup> status and alarms. The combination needs no physical I/O and represents only ONE device on the fieldbus network. The two PT1000 inputs are used as volt-free digital.

### Example 2:

NovoCon I/O is used to control ChangeOver<sup>6</sup> actuator position without status and alarm feedback. The analog input is read the value of a pressure sensor for pump speed optimisation. The two PT1000 inputs are used to read actual room temperature and set temperature.

### Example 3:

NovoCon I/O is used to control ChangeOver<sup>6</sup> actuator position as well as read ChangeOver<sup>6</sup> status and alarm input. The two PT1000 inputs are used to read supply and return temperature for calculating energy consumed.

### Example 4:

I/O from 2 NovoCons is used to control ec motor fan speed and read feedback (also as pulsed input). Control damper position and monitor condensation as well as read air temperature of feed and exhaust via PT1000 inputs or connect key card interlock and monitor room display unit.

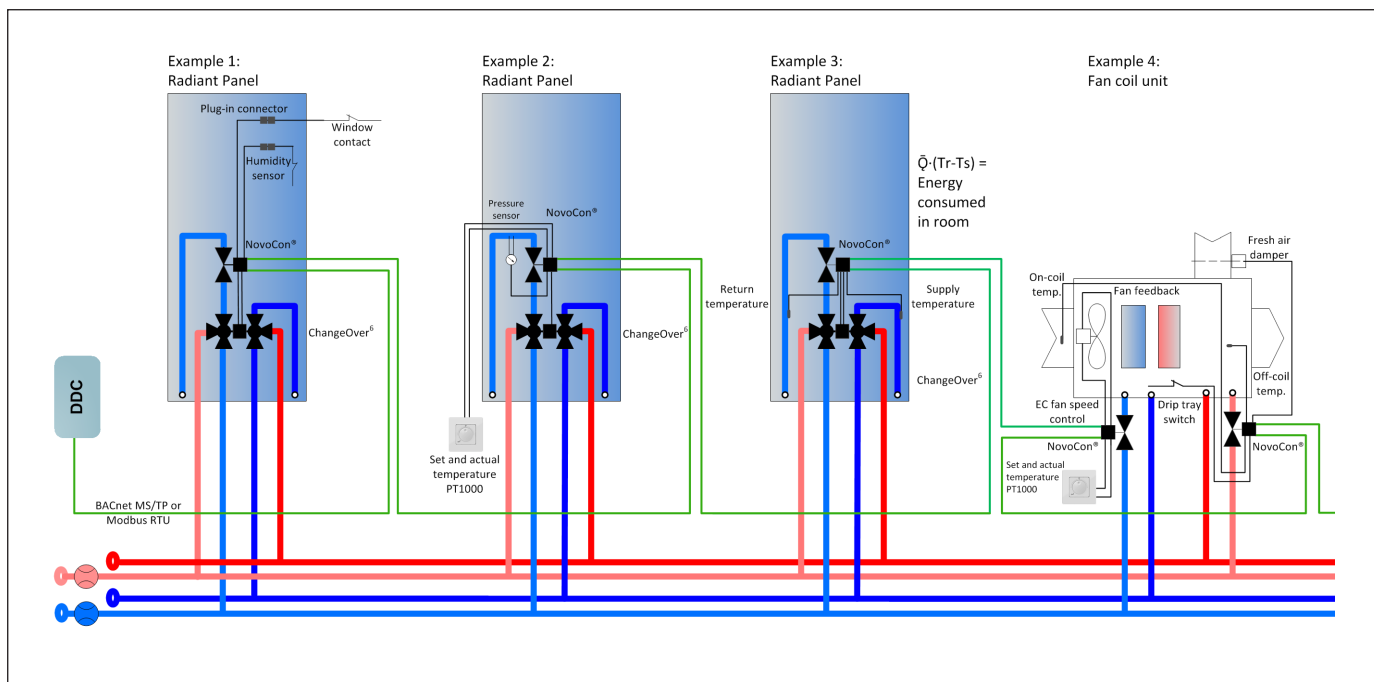

## Connect with us online to **learn more**

At Danfoss, we engineer the most innovative HVAC solutions of tomorrow ... today. We do this by focusing on solutions that reduce climate impact while contributing to the productivity and well-being of the people that work with and rely on our services all over the world. To learn more about the NovoCon<sup>®</sup> S, the AB-QM valve or the Danfoss organization, please visit our website at:

[novocon.com](http://novocon.com)



### Introduction to the new NovoCon<sup>®</sup> S digital actuator

Scan the QR code and see how we connect experience and innovation.

Danfoss A/S · Heating Segment · Ulvehavevej 61 · 7100 Vejle · Denmark  
Tel.: +45 7488 8500 · Email: [heating@danfoss.com](mailto:heating@danfoss.com) · [www.heating.danfoss.com](http://www.heating.danfoss.com)

Danfoss can accept no responsibility for possible errors in catalogues, brochures and other printed material. Danfoss reserves the right to alter its products without notice. This also applies to products already on order provided that such alterations can be made without sub sequential changes being necessary in specifications already agreed. All trademarks in this material are property of the respective companies. Danfoss and the Danfoss logotype are trademarks of Danfoss A/S. All rights reserved.