

Actuator Submittal, Proportional AME 120 NLX- 1 Motor Actuator

DATE:	SPECIFICATION SECTION:			PAGE:	of	
PROJECT	ARCHITECT/ENGINEER	AGENCY	REPRESENTATIVE	DATE	NOTES	
		ARCHITECT				
		ENGINEER				
	SUPPLIER	CONTRACTOR	CONTRACTOR 1			
			CONTRACTOR 2			
			OTHER			
			<i>NOTE</i>	<i>COMMENT</i>		
ORDER NO.						

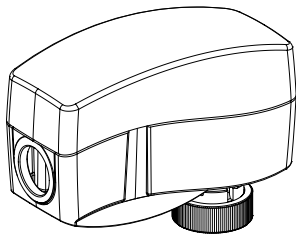

Model	Number	Unit Tag	Qty
AME120 NLX - 1			

Specification

The motor actuator shall be 24VAC powered and mount to the AB-QM valve body in sizes ranging from ½" to 1¼" valve sizes. The actuator shall be UL listed according to ANSI/ UL 6073-1 and 6073-2-14 and plenum rated according to UL2043. Control input signal for the actuator shall utilize a proportional control signal selectable via internal DIP switch setting in the ranges of 0(2)-10VDC or 0(4) to 20mA. The actuator shall have feedback signal and periodic exercise valve stem function. The operation of the actuator shall have integrated no load calibration function to learn and apply the input signal to the calibrated stem travel. The actuator shall have a visual indication to monitor the actuator's travel and LED feedback for actuator operation.

Description

The AME 120 NLX is a gear motor actuator assembled to the AB-QM valves. The AME actuator utilizes a proportional control signal to precisely adjust the valve to the necessary load requirement within the space. The compact profile of the actuator and valve are ideal for fan coil units, induction units, and zone heating and cooling terminal applications located in plenum locations or within enclosures. Other features include:

- Gap detection at stem up position
- Force switch-off at stem down position preventing overload of actuator and valve.
- No tools required for mounting
- Maintenance free during lifetime
- Low noise operation
- Manual override

Actuator Type	AME 120 NLX- 1
Code No.	082H5004
Power Supply	24 VAC; +10%... -15%
Electrical Connection	½" electrical conduit, wiring terminal block
Power Consumption	1.5VA
Frequency	50/60 Hz
Control Input	0(2)...10VDC / 0(4)...20mA
Output Signal	0...10VDC
Actuator Force	29.2 lbf (130N)
Max. Stem Travel	5mm
Travel Speed	12 s/mm @ 50Hz, 10 s/mm @ 60Hz
Max. Medium Temp.	248°F (120°C)
Ambient Temp.	32 to 131°F (0 to 55 °C)
Humidity	5 to 95% RH, noncondensing
Weight	0.66lb (0.3kg)

Regulatory Compliance:

	USA	UL Listed, CCN XABE, File E480529; to ANSI/UL 60730-1 and ANSI/UL 60730-2-14 Investigated and approved for plenum use in accordance with UL 2043
	Canada	UL Listed, CCN XABE7, File E48029; to CAN/CSA-E60730-1:13 and CAN/CSA-E60730-2-14:13
	Europe	CE Mark - Danfoss declares that this product complies with all relevant CE-marking directives

Submittal

AB-QM Pressure Independent Balance and Control Valve

Orientation

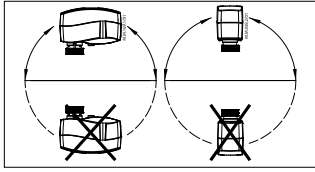

The actuator should be mounted with the valve stem in either horizontal position or pointing upwards. The actuator is fixed to the valve body by means of a threaded mounting ring which is tightened by hand and requires no additional tools for mounting. Mount the actuator prior to wiring it with power.

Wiring

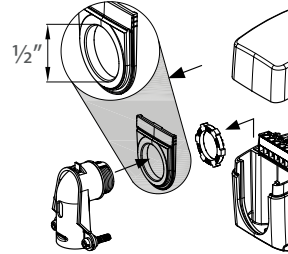
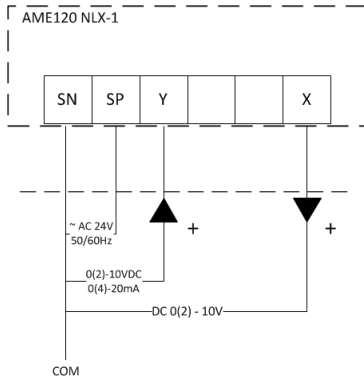

A field supplied 1/2" trade size electrician's fitting and lock nut can be mounted to the actuator enclosure. Insert wiring material through the removable plug or conduit fitting, and wire connection to the terminal block.

Position Indication

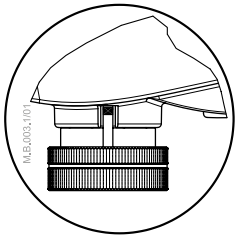

External position indication located at the neck of the motor actuator

Manual Operation

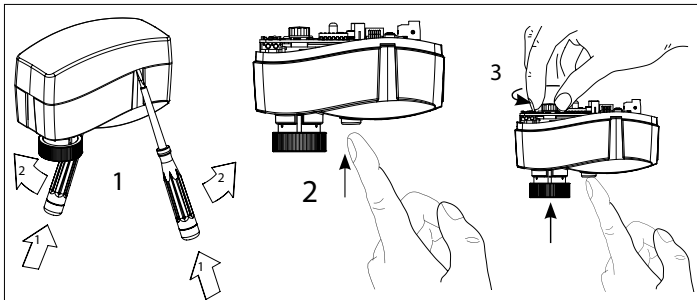

DIP Switches

AME120 NLX- 1 (082H5001)

DIP Switch	Function	Description
1	Input Range	0(2) to 10 VDC or 0(4) to 20 mA
2	Direct/ Reverse Reaction	Reaction of actuator based upon input signal
3	Sequential option	Splitting of input signal
4	Sequential selection range	Operation of input signal range
5	Equal percentage/ Linear characteristic	Actuator's characteristic response to input signal
6	Excercise function	Fully opens and closes valve every 7 days
7	Input Range	Voltage (VDC) / Current (mA)

Calibration Reset

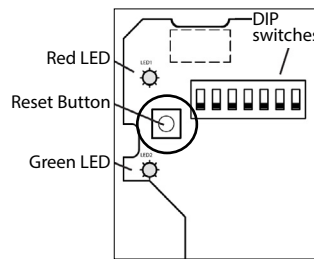

To initiate the calibration of the actuator to match the travel of the valve press and hold the RESET button for 2 seconds.

Dimensions

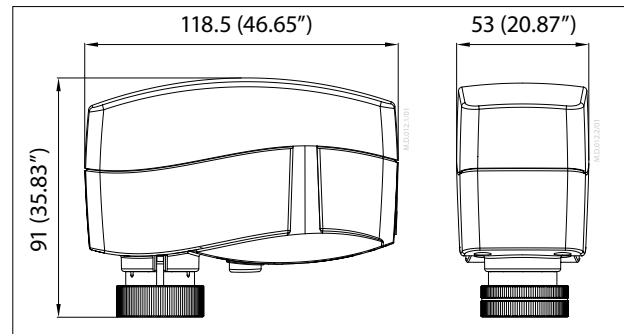

Danfoss can accept no responsibility for possible errors in printed materials and reserves the right to alter its products without notice. All trademarks in this material are property of the respective companies. Danfoss and Danfoss logotype are trademarks of Danfoss A/S. All rights reserved.



Danfoss
 Toronto, ON / Baltimore, MD
 Tel.: 888.326.3677, option 3
 Fax: 416-352-5981
 www.heating.danfoss.us