

Operating Guide

VLT Servo Drive System ISD 520/DSD 520

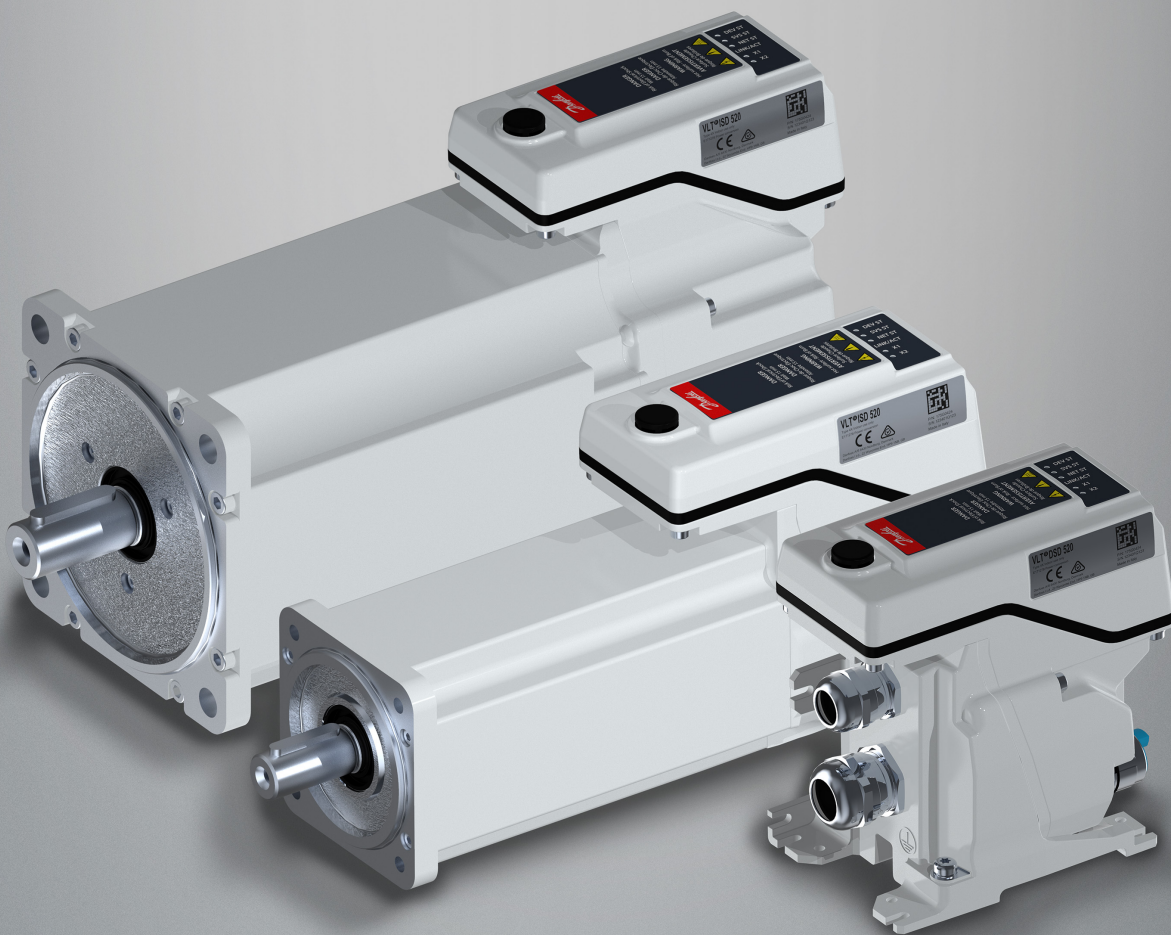

Contents

1 Introduction

| | |
|------------------------------------|----|
| 1.1 Purpose of the Operating Guide | 17 |
| 1.2 Additional Resources | 17 |
| 1.3 Copyright | 17 |
| 1.4 Document Version | 17 |
| 1.5 Approvals and Certifications | 18 |
| 1.6 Firmware Updates | 19 |
| 1.7 Terminology | 19 |

2 Safety

| | |
|---|----|
| 2.1 Safety Symbols | 21 |
| 2.2 Important Safety Warnings | 21 |
| 2.3 Safety Instructions and Precautions | 23 |
| 2.4 Operational Safety | 24 |
| 2.5 Qualified Personnel | 24 |
| 2.6 Due Diligence | 24 |
| 2.7 Intended Use | 25 |
| 2.7.1 Prohibited Application Areas | 25 |
| 2.8 Foreseeable Misuse | 25 |
| 2.9 Service and Support | 25 |

3 System Description

| | |
|--|----|
| 3.1 Overview of the ISD 520/DSD 520 Servo System | 26 |
| 3.2 VLT® Integrated Servo Drive ISD 520 | 27 |
| 3.2.1 Overview of the ISD 520 Servo Drive | 27 |
| 3.2.2 Motor and Flange Sizes | 28 |
| 3.2.3 ISD 520 Servo Drive Types | 28 |
| 3.2.4 Motor Components | 31 |
| 3.2.4.1 Shaft | 31 |
| 3.2.4.2 Brake (Optional) | 31 |
| 3.2.4.3 Cooling | 31 |
| 3.2.4.4 Thermal Protection | 31 |
| 3.2.4.5 Built-in Feedback Devices | 31 |
| 3.2.5 Drive Components | 32 |

| | |
|---|----|
| 3.2.5.1 Connectors on the ISD 520 Servo Drives | 32 |
| 3.3 VLT® Decentral Servo Drive DSD 520 | 32 |
| 3.3.1 Overview of the DSD 520 Servo Drive | 32 |
| 3.3.2 DSD 520 Servo Drive Types | 33 |
| 3.4 Power Supply Module (PSM 510) | 34 |
| 3.4.1 Overview of PSM 510 | 34 |
| 3.5 Decentral Access Module (DAM 510) | 35 |
| 3.5.1 Overview of DAM 510 | 35 |
| 3.6 Auxiliary Capacitors Module (ACM 510) | 37 |
| 3.6.1 Overview of ACM 510 | 37 |
| 3.7 Expansion Module (EXM 510) | 37 |
| 3.8 Cables | 39 |
| 3.8.1 Hybrid Cable | 39 |
| 3.8.1.1 Minimum Bending Radius for Hybrid Cable | 40 |
| 3.8.2 I/O and/or Encoder Cable | 40 |
| 3.8.3 Fieldbus Extension Cable | 40 |
| 3.8.4 LCP Cable | 40 |
| 3.9 Cable Layout and Routing | 40 |
| 3.9.1 Standard Cabling Concept for 2 Lines | 40 |
| 3.10 Local Control Panel | 41 |
| 3.10.1 Overview of the Local Control Panel | 41 |
| 3.10.2 Layout of the Local Control Panel | 41 |
| 3.10.2.1 A: Display area | 42 |
| 3.10.2.2 B: Display menu keys | 44 |
| 3.10.2.3 C: Navigation keys and indicator lights (LEDs) | 45 |
| 3.10.2.4 D: Operation keys and reset | 45 |
| 3.11 Software | 46 |
| 3.12 Fieldbus | 46 |
| 3.12.1 Overview | 46 |
| 3.12.2 EtherCAT® | 47 |
| 3.12.3 Ethernet POWERLINK® | 48 |
| 3.12.4 PROFINET® | 48 |

4 Mechanical Installation

| | |
|--------------------|----|
| 4.1 Items Supplied | 50 |
| 4.2 Transport | 50 |

| | | |
|---------|---|----|
| 4.3 | Inspection on Receipt | 50 |
| 4.4 | Safety Measures during Installation | 50 |
| 4.5 | Installation Environment | 51 |
| 4.5.1 | Overview | 51 |
| 4.5.2 | ISD 520/DSD 520 Servo Drive | 51 |
| 4.5.3 | System Modules | 51 |
| 4.6 | Preparation for Installation | 51 |
| 4.6.1 | Preparation for Installation of ISD 520/DSD 520 Servo Drive | 51 |
| 4.6.2 | Preparation for Installation of System Modules | 52 |
| 4.6.3 | Drilling Templates | 52 |
| 4.7 | Installation Procedure | 53 |
| 4.7.1 | Space Requirements for ISD 520 Servo Drive | 53 |
| 4.7.2 | Space Requirements for DSD 520 Servo Drive | 53 |
| 4.7.3 | Space Requirements for System Modules | 54 |
| 4.7.4 | Installation Aids and Tools Required | 56 |
| 4.7.5 | Fitting Instructions for ISD 520 Servo Drive | 56 |
| 4.7.5.1 | Overview | 56 |
| 4.7.5.2 | Clamping the ISD 520 Servo Drive | 56 |
| 4.7.5.3 | Coupling the ISD 520 Servo Drive | 57 |
| 4.7.5.4 | Fixing Screws and Tightening Torques | 57 |
| 4.7.6 | Fitting Instruction for DSD 520 Servo Drive | 58 |
| 4.7.6.1 | Overview | 58 |
| 4.7.6.2 | Clamping the DSD 520 Servo Drive | 58 |
| 4.7.7 | Fitting Instructions for System Modules | 59 |

5 Electrical Installation

| | | |
|---------|--|----|
| 5.1 | Warnings for Electrical Installation | 64 |
| 5.2 | Electrical Environmental Conditions | 64 |
| 5.3 | EMC-Compliant Installation | 65 |
| 5.4 | Grounding for Electrical Safety | 65 |
| 5.4.1 | Grounding the ISD 520 Servo Drive | 65 |
| 5.4.1.1 | Grounding using the Flange | 65 |
| 5.4.1.2 | Grounding using the PE Screws | 66 |
| 5.4.2 | Grounding the DSD 520 Servo Drive | 67 |
| 5.4.3 | Grounding the System Modules | 67 |
| 5.5 | Grounding for EMC-Compliant Installation | 69 |

| | |
|--|----|
| 5.6 Mains Supply Requirements | 70 |
| 5.6.1 Fuses | 70 |
| 5.6.2 Circuit Breakers | 70 |
| 5.6.3 Additional Specifications | 71 |
| 5.7 Auxiliary Supply Requirements | 71 |
| 5.7.1 Fuses | 71 |
| 5.8 Safety Supply Requirements | 71 |
| 5.9 UL Requirements | 72 |
| 5.10 Connecting the ISD 520/DSD 520 Servo Drive | 72 |
| 5.10.1 Electrical Installation Warnings for ISD 520/DSD 520 Servo Drive | 72 |
| 5.10.2 General Instructions for Cable Installation | 73 |
| 5.10.3 Connecting Hybrid Cables | 74 |
| 5.10.4 Disconnecting Hybrid Cables | 75 |
| 5.10.5 Connecting Cables to Ports X3, X4, and X5 | 75 |
| 5.10.5.1 Cable Routing Recommendations | 75 |
| 5.10.5.2 Connecting I/O Cables to Ports X3 and X4 | 75 |
| 5.10.5.3 Connecting the LCP Cable to Port X5 | 76 |
| 5.10.6 Disconnecting Cables from Ports X3, X4, and X5 | 76 |
| 5.10.7 Connecting the Wires on DSD 520 | 76 |
| 5.11 Connecting the Power Supply Module PSM 510 | 76 |
| 5.11.1 AC Line Choke | 76 |
| 5.11.1.1 Connecting 1 PSM 510 to the AC Choke | 77 |
| 5.11.1.2 Connecting 2 PSM 510 Modules to the AC Choke | 78 |
| 5.11.1.3 Connecting 2 PSM 510 Modules to the AC Choke with System Splitting | 79 |
| 5.12 Connecting the Cables on the Power Supply Module PSM 510 | 80 |
| 5.12.1 Connecting the Cables on the Top of the Power Supply Module PSM 510 | 80 |
| 5.12.2 Connecting the Cables on the Bottom of the Power Supply Module PSM 510 | 81 |
| 5.13 Connecting the Decentral Access Module DAM 510 | 81 |
| 5.13.1 Connecting the Cables on the Top of the Decentral Access Module DAM 510 | 81 |
| 5.13.2 Connecting the Feed-In Cable | 82 |
| 5.14 Connecting the Auxiliary Capacitors Module ACM 510 | 83 |
| 5.15 Connecting the Expansion Module EXM 510 | 84 |
| 5.16 Connecting the Brake Resistor on the PSM 510 | 85 |

6 Commissioning

| | |
|--------------------------------|----|
| 6.1 Warnings for Commissioning | 87 |
|--------------------------------|----|

| | | |
|-----------|---|----|
| 6.2 | Pre-Commissioning Checklist | 87 |
| 6.3 | EtherCAT® ID Assignment | 87 |
| 6.4 | Ethernet POWERLINK® ID Assignment | 87 |
| 6.4.1 | Overview | 87 |
| 6.4.2 | Single Device ID Assignment | 87 |
| 6.4.2.1 | Setting the Node ID Directly on a Servo Drive or on the System Modules | 87 |
| 6.4.2.2 | Setting the Node ID for a Single Servo Drive via the Power Supply Module (PSM 510) or Decentral Access Module (DAM 510) using the LCP | 88 |
| 6.4.3 | Multiple Device ID Assignment | 89 |
| 6.4.3.1 | Setting the Node IDs of all Servo Drives and System Modules on a Decentral Access Module (DAM 510)/Power Supply Module (PSM 510) Line | 89 |
| 6.5 | PROFINET® ID Assignment | 90 |
| 6.6 | Power-Up Time | 90 |
| 6.7 | System Module Charging Time | 90 |
| 6.8 | Switching on the ISD 520/DSD 520 System | 90 |
| 6.8.1 | Procedure for Switching on the ISD 520/DSD 520 System | 91 |
| 6.9 | Libraries | 91 |
| 6.10 | Programming with Automation Studio™ | 91 |
| 6.10.1 | Requirements for Programming with Automation Studio™ | 91 |
| 6.10.2 | Creating an Automation Studio™ Project | 91 |
| 6.10.3 | Including the Servo Motion Libraries into an Automation Studio™ Project | 92 |
| 6.10.4 | Constants within the DDS_Drive Library | 92 |
| 6.10.5 | Instantiating AXIS_REF_DDS in Automation Studio™ | 93 |
| 6.10.6 | Instantiating PSM_REF in Automation Studio™ | 94 |
| 6.10.7 | Instantiating DAM_REF in Automation Studio™ | 94 |
| 6.10.8 | Instantiating ACM_REF in Automation Studio™ | 94 |
| 6.10.9 | Importing a Servo Drive into Automation Studio™ | 94 |
| 6.10.9.1 | Version V4.x | 94 |
| 6.10.10 | Importing PSM 510, DAM 510, and ACM 510 into Automation Studio™ | 95 |
| 6.10.10.1 | Version V4.x | 95 |
| 6.10.11 | I/O Configuration and I/O Mapping | 96 |
| 6.10.12 | Setting the PLC Cycle Time | 98 |
| 6.10.13 | Connecting to the PLC | 98 |
| 6.11 | Programming with TwinCAT® | 99 |
| 6.11.1 | Requirements for Programming with TwinCAT® | 99 |
| 6.11.2 | Creating a TwinCAT® Project | 99 |

| | |
|--|-----|
| 6.11.3 Including the TwinCAT® Library into a TwinCAT® Project | 99 |
| 6.11.4 Constants within the DDS_Drive Library | 101 |
| 6.11.5 Instantiating AXIS_REF_DDS in TwinCAT® | 102 |
| 6.11.6 Instantiating PSM_REF in TwinCAT | 103 |
| 6.11.7 Instantiating DAM_REF in TwinCAT | 103 |
| 6.11.8 Instantiating ACM_REF in TwinCAT | 104 |
| 6.11.9 Adding a PLC Project to TwinCAT® System Manager | 104 |
| 6.11.10 Importing Devices to TwinCAT® | 105 |
| 6.11.11 I/O Configuration and I/O Mapping | 108 |
| 6.11.12 Attaching the Input and Output Variables to the Physical Data Points | 109 |
| 6.11.13 Configuring the Real-Time | 111 |
| 6.11.14 Configuration as a TwinCAT® NC Axis | 112 |
| 6.11.14.1 I/O Configuration for Servo Drives used as NC Axes | 112 |
| 6.11.15 Loading the Program Code and Starting the PLC | 113 |
| 6.12 Programming Guidelines for Automation Studio™ and TwinCAT® | 113 |
| 6.13 Programming with TIA | 113 |
| 6.13.1 Requirements for Programming with TIA | 113 |
| 6.13.2 Creating a TIA Project | 114 |
| 6.13.3 Including the Servo Motion Libraries into a TIA Project | 114 |
| 6.13.4 Importing Devices into TIA | 115 |
| 6.13.5 Creating a Network in TIA | 116 |
| 6.14 Programming Guidelines for TIA | 121 |
| 6.15 VLT® Servo Toolbox Software | 123 |
| 6.15.1 Overview | 123 |
| 6.15.2 System Requirements | 123 |
| 6.15.3 Installing the VLT® Servo Toolbox Software | 124 |
| 6.15.4 VLT® Servo Toolbox Communication | 124 |
| 6.15.4.1 Overview | 124 |
| 6.15.4.2 Firewall | 124 |
| 6.15.4.3 Indirect Communication | 124 |
| 6.15.4.4 Direct Communication | 127 |
| 6.15.5 VLT® Servo Toolbox Commissioning | 129 |
| 6.15.5.1 Step 1: Opening the Main Window | 129 |
| 6.15.5.2 Step 2: Connecting to Network | 130 |
| 6.15.5.3 Step 3: Scanning for Devices | 131 |
| 6.16 Motion Library | 131 |

| | |
|---|-----|
| 6.16.1 Simple Programming Template | 131 |
| 6.16.2 Function Blocks | 131 |
| 7 Operation | |
| 7.1 DS402 Operating Modes | 133 |
| 7.2 PROFIdrive Application Classes | 133 |
| 7.3 Motion Functions | 134 |
| 7.4 Operating Indicator Lights (LEDs) | 134 |
| 7.4.1 Operating Indicator Lights (LEDs) on the ISD 520/DSD 520 Servo Drives | 134 |
| 7.4.2 Operating Indicator Lights (LEDs) on PSM 510 | 135 |
| 7.4.3 Operating Indicator Lights (LEDs) on DAM 510 | 136 |
| 7.4.4 Operating Indicator Lights (LEDs) on ACM 510 | 138 |
| 8 Functional Safety Concept | |
| 8.1 Functional Description | 140 |
| 8.2 Safety Precautions | 140 |
| 8.3 Qualified Personnel for Working with Functional Safety | 141 |
| 8.4 Applied Standards and Compliance | 141 |
| 8.5 Abbreviations and Conventions | 142 |
| 8.6 Installation | 142 |
| 8.6.1 Protective Measures | 143 |
| 8.7 Application Example | 143 |
| 8.8 Commissioning Test | 144 |
| 8.8.1 Commissioning Test using Libraries | 144 |
| 8.8.2 Commissioning Test using PROFINET® Devices | 146 |
| 8.9 Operation of the STO Function | 147 |
| 8.9.1 Error Codes | 147 |
| 8.9.2 Fault Reset | 148 |
| 8.10 Functional Safety Characteristic Data | 148 |
| 8.11 Maintenance, Security, and User Accessibility | 148 |
| 9 Diagnostics | |
| 9.1 Faults | 149 |
| 9.2 Troubleshooting | 149 |
| 9.2.1 Troubleshooting for the Servo Drives (ISD 520/DSD 520) | 149 |

| | | |
|----------|--|-----|
| 9.2.1.1 | Drive not Running/Starting Slowly | 149 |
| 9.2.1.2 | Drive Hums and Draws High Current | 149 |
| 9.2.1.3 | Drive Stops Suddenly and Restart is not Possible | 150 |
| 9.2.1.4 | Motor Rotating in Wrong Direction | 150 |
| 9.2.1.5 | Motor not Generating Expected Torque | 150 |
| 9.2.1.6 | Drive Screaming | 150 |
| 9.2.1.7 | Uneven Running | 151 |
| 9.2.1.8 | Vibration | 151 |
| 9.2.1.9 | Unusual Running Noises | 151 |
| 9.2.1.10 | Drive Speed Drops Sharply under Load | 151 |
| 9.2.1.11 | Brake not Releasing | 151 |
| 9.2.1.12 | Holding Brake not Holding the Servo Drive | 152 |
| 9.2.1.13 | Delayed Brake Engagement | 152 |
| 9.2.1.14 | Noises when Power-Off Brake is Engaged | 152 |
| 9.2.1.15 | Indicator Lights (LEDs) not Lighting Up | 152 |
| 9.2.1.16 | Drive Protection Trips Immediately | 152 |
| 9.2.2 | Troubleshooting for the Servo System | 152 |
| 9.2.2.1 | LCP Display is Dark/Not Functioning | 152 |
| 9.2.2.2 | Open Power Fuses or Circuit Breaker Trip | 153 |
| 9.2.2.3 | DC-link Voltage Too Low (Error 0x3220/0x104) | 153 |
| 9.2.2.4 | Current Overload Trip (Error 0x2396/0x15C) | 153 |
| 9.2.2.5 | High Cont. Power Overload (Error 0x2313/0x161) | 153 |
| 9.2.2.6 | Continuous Power Overload (Error 0x2314/0x162) | 154 |
| 9.2.2.7 | AUX Overcurrent (Error 0x2391/0x125) | 154 |
| 9.2.2.8 | AUX Overvoltage (Error 0x3292/0x133) | 154 |
| 9.2.2.9 | AUX Undervoltage (Error 0x3294/0x135) | 154 |
| 9.2.2.10 | Mains Phase Loss (Error 0x3130/0x12F) | 154 |
| 9.2.2.11 | Generic Application Error (Error 0x1000/0x100) | 155 |
| 9.2.2.12 | Grounding Fault | 155 |
| 9.2.2.13 | Brake Resistor Error | 155 |
| 9.2.2.14 | Brake Chopper Error | 155 |
| 9.2.2.15 | Internal Fan Error | 155 |
| 9.3 | Error Codes for ISD 520/DSD 520 Servo System | 156 |
| 9.3.1 | No error (0x0000 / 0x0) | 156 |
| 9.3.2 | Generic application error (0x1000 / 0x100) | 156 |
| 9.3.3 | Overcurrent Trip (0x2310 / 0x101) | 156 |
| 9.3.4 | High cont. current overload (0x2311 / 0x15F) | 156 |
| 9.3.5 | Continuous current overload (0x2312 / 0x160) | 156 |

| | |
|---|-----|
| 9.3.6 High cont. power overload (0x2313 / 0x161) | 157 |
| 9.3.7 Continuous power overload (0x2314 / 0x162) | 157 |
| 9.3.8 Overcurrent short circuit (0x2320 / 0x163) | 157 |
| 9.3.9 Ground fault (0x2330 / 0x151) | 157 |
| 9.3.10 AUX overcurrent (0x2391 / 0x125) | 157 |
| 9.3.11 AUX user limit current (0x2393 / 0x127) | 158 |
| 9.3.12 AUX user limit current warning (0x2394 / 0x128) | 158 |
| 9.3.13 AUX supply failure (0x2395 / 0x129) | 158 |
| 9.3.14 Current overload trip (0x2396 / 0x15C) | 158 |
| 9.3.15 Power overload trip (0x2397 / 0x12B) | 159 |
| 9.3.16 Thermal overload motor (0x239B / 0x102) | 159 |
| 9.3.17 DC Short Circuit (0x239C / 0x16F) | 159 |
| 9.3.18 Overcurrent motor (0x239D / 0x170) | 159 |
| 9.3.19 Mains phase loss (0x3130 / 0x12F) | 159 |
| 9.3.20 DC link overvoltage (0x3210 / 0x103) | 160 |
| 9.3.21 DC link undervoltage (0x3220 / 0x104) | 160 |
| 9.3.22 DC link charging error (0x3230 / 0x152) | 160 |
| 9.3.23 DC Link unbalanced (0x3280 / 0x153) | 161 |
| 9.3.24 UAUX high voltage (0x3291 / 0x132) | 161 |
| 9.3.25 UAUX overvoltage (0x3292 / 0x133) | 161 |
| 9.3.26 UAUX low voltage (0x3293 / 0x134) | 161 |
| 9.3.27 UAUX undervoltage (0x3294 / 0x135) | 161 |
| 9.3.28 DC link high voltage (0x3295 / 0x136) | 162 |
| 9.3.29 DC link low voltage (0x3296 / 0x137) | 162 |
| 9.3.30 UAUX charging error (0x3297 / 0x154) | 162 |
| 9.3.31 DC link shutdown error (0x3298 / 0x165) | 162 |
| 9.3.32 UAUX shutdown error (0x3299 / 0x155) | 162 |
| 9.3.33 UAUX undervoltage hardware (0x329A / 0x156) | 163 |
| 9.3.34 Automated fault reset failure (0x329B / 0x168) | 163 |
| 9.3.35 Device overtemperature (0x4210 / 0x157) | 163 |
| 9.3.36 Device under temperature (0x4220 / 0x138) | 163 |
| 9.3.37 Overtemperature: Control card (0x4291 / 0x106) | 164 |
| 9.3.38 Overtemperature: Power card (0x4292 / 0x107) | 164 |
| 9.3.39 Inrush overtemperature DC link (0x4293 / 013C) | 164 |
| 9.3.40 Inrush overtemperature AUX line (0x4294 / 0x13D) | 164 |
| 9.3.41 Overtemperature: Motor (0x4310 / 0x108) | 165 |

| | |
|--|-----|
| 9.3.42 AUX undervoltage (0x5112 / 0x135) | 165 |
| 9.3.43 Charge switch failure voltage (0x5121 / 0x158) | 165 |
| 9.3.44 Failure on output phase U (0x5411 / 0x123) | 165 |
| 9.3.45 Failure on output phase V (0x5412 / 0x124) | 166 |
| 9.3.46 Failure on output phase W (0x5413 / 0x125) | 166 |
| 9.3.47 EE Checksum Error (parameter missing) (0x5530 / 0x10A) | 166 |
| 9.3.48 Parameter error (0x6320 / 0x10B) | 166 |
| 9.3.49 Parameter Configuration: Previous configuration restored (0x6321 / 0x171) | 166 |
| 9.3.50 Parameter Configuration: Power cycle needed (0x6322 / 0x172) | 167 |
| 9.3.51 Parameter Configuration: Wrong thermal sensor configuration (0x6323 / 0x0173) | 167 |
| 9.3.52 Conf par ver (0x6382 / 0x15D) | 167 |
| 9.3.53 Configuration parameters limits error (0x6383 / 0x164) | 168 |
| 9.3.54 Power EEprom configuration error (0x6384 / 0x166) | 168 |
| 9.3.55 Brake chopper failure (0x7111 / 0x141) | 168 |
| 9.3.56 Brake chopper overcurrent (0x7112 / 0x167) | 169 |
| 9.3.57 Brake chopper module overload (0x7181 / 0x142) | 169 |
| 9.3.58 External brake chopper overload (0x7182 / 0x143) | 169 |
| 9.3.59 Brake mains voltage too high (0x7183 / 0x159) | 170 |
| 9.3.60 Internal position sensor error (0x7320 / 0x10C) | 170 |
| 9.3.61 External position sensor error (0x7380 / 0x10D) | 170 |
| 9.3.62 Communication error (0x7500 / 0x169) | 171 |
| 9.3.63 Following error (0x8611 / 0x10E) | 171 |
| 9.3.64 Homing error on entering homing mode (0x8693 / 0x10F) | 171 |
| 9.3.65 Homing error on start homing method (0x8694 / 0x110) | 171 |
| 9.3.66 Homing error distance (0x8695 / 0x111) | 172 |
| 9.3.67 Mechanical brake failure (0xFF01 / 0x112) | 172 |
| 9.3.68 Short circuit in mechanical brake control (0xFF02 / 0x113) | 172 |
| 9.3.69 External interface power failure (0xFF0A / 0x114) | 172 |
| 9.3.70 Fan feedback inconsistent (0xFF21 / 0x145) | 173 |
| 9.3.71 Fan lifetime critical (0xFF22 / 0x15A) | 173 |
| 9.3.72 Timing violation 1 (0xFF60 / 0x115) | 173 |
| 9.3.73 Timing violation 2 (0xFF61 / 0x116) | 173 |
| 9.3.74 Timing violation 3 (0xFF62 / 0x117) | 173 |
| 9.3.75 Timing violation 4 (0xFF63 / 0x118) | 173 |
| 9.3.76 Timing violation 5 (0xFF64 / 0x119) | 174 |
| 9.3.77 Timing violation 6 (0xFF65 / 0x11A) | 174 |

| | | |
|--------|---|-----|
| 9.3.78 | Timing violation 7 (0xFF66 / 0x168) | 174 |
| 9.3.79 | Timing violation 8 (0xFF67 / 0x16B) | 174 |
| 9.3.80 | Timing violation 9 (0xFF68 / 0x16C) | 174 |
| 9.3.81 | Firmware: Package description mismatch (0xFF70 / 0x11B) | 175 |
| 9.3.82 | Firmware: Power cycle needed (0xFF71 / 0x11C) | 175 |
| 9.3.83 | Firmware: Update started (0xFF72 / 0x11D) | 175 |
| 9.3.84 | Firmware: Update invalid (0xFF73 / 0x15B) | 175 |
| 9.3.85 | STO active while drive enabled (0xFF80 / 0x11E) | 176 |
| 9.3.86 | STO mismatch (0xFF81 / 0x11F) | 176 |
| 9.3.87 | Guide value reversed (0xFF90 / 0x121) | 176 |
| 9.3.88 | Guide value implausible (0xFF91 / 0x122) | 176 |
| 9.3.89 | UDU Guide Value out of range (0xFF92 / 0x126) | 177 |
| 9.3.90 | UDU Guide Value Offset out of range (0xFF93 / 0x12A) | 177 |
| 9.3.91 | UDU Min Blending distance out of range (0xFF94 / 0x12C) | 177 |
| 9.3.92 | Sign of life error (0xFF95 / 0x14E) | 177 |
| 9.3.93 | Safe Drive Internal Failure (0xFF96 / 0x150) | 178 |
| 9.3.94 | SIM Internal Failure (0xFF97 / 0x16E) | 178 |
| 9.3.95 | SIM Internal Failure Resettable (0xFF98 / 0x174) | 178 |
| 9.3.96 | Safe Position Procedure Failed (0xFF99 / 0x175) | 178 |

10 Maintenance, Decommissioning, and Disposal

| | | |
|--------|---|-----|
| 10.1 | Warnings | 179 |
| 10.2 | Inspection During Operation | 179 |
| 10.2.1 | ISD 520/DSD 520 Servo Drives | 179 |
| 10.2.2 | System Modules | 179 |
| 10.3 | Maintenance Tasks | 180 |
| 10.4 | Repair | 180 |
| 10.5 | ISD 520/DSD 520 Servo Drive Replacement | 180 |
| 10.5.1 | Dismounting the ISD 520/DSD 520 Servo Drive | 180 |
| 10.5.2 | Fitting and Commissioning the ISD 520/DSD 520 Servo Drive | 180 |
| 10.6 | System Module Replacement | 181 |
| 10.6.1 | Dismounting the System Modules | 181 |
| 10.6.2 | Fitting and Commissioning the System Modules | 183 |
| 10.7 | Cable Replacement | 183 |
| 10.7.1 | Overview | 183 |
| 10.7.2 | Feed-in Cable Replacement | 183 |

| | | |
|-----------|---|-----|
| 10.7.2.1 | Disconnecting the Feed-in Cable | 183 |
| 10.7.2.2 | Replacing the Feed-in Cable | 184 |
| 10.7.2.3 | Connecting the Feed-in Cable | 184 |
| 10.7.3 | Loop Cable Replacement | 184 |
| 10.7.3.1 | Connecting the Loop Cable | 184 |
| 10.7.3.2 | Replacing the Loop Cable | 185 |
| 10.7.3.3 | Disconnecting the Loop Cable | 185 |
| 10.8 | Fuse Replacement in Decentral Access Module (DAM 510) | 185 |
| 10.9 | Fan Replacement | 186 |
| 10.10 | Product Returns | 187 |
| 10.11 | Recycling | 187 |
| 10.12 | Disposal | 187 |
| | | |
| 11 | Specifications | |
| 11.1 | Product Labels | 188 |
| 11.1.1 | Product Labels on the ISD 520/DSD 520 Servo Drive | 188 |
| 11.1.2 | Product Labels on the System Modules | 189 |
| 11.2 | Characteristic Data | 191 |
| 11.2.1 | Characteristic Data for ISD 520 Servo Drive | 191 |
| 11.2.1.1 | Common Technical Data for ISD 520 Servo Drives | 191 |
| 11.2.1.2 | Characteristic Data for Drive Sizes 1–2 in Normal Speed Range (2000–3000 RPM) | 191 |
| 11.2.1.3 | Characteristic Data for Drive Sizes 3–5 in Normal Speed Range (2000–3000 RPM) | 193 |
| 11.2.1.4 | Characteristic Data for Drive Sizes 1–2 in High Speed Range (4500–6000 RPM) | 194 |
| 11.2.1.5 | Characteristic Data for Drive Sizes 3–5 in High Speed Range (4500–6000 RPM) | 195 |
| 11.2.1.6 | Mechanical Data for Drive Sizes 1–2 in Normal Speed Range (2000–3000 RPM) | 196 |
| 11.2.1.7 | Mechanical Data Drive Sizes 3–5 in Normal Speed Range (2000–3000 RPM) | 197 |
| 11.2.1.8 | Mechanical Data for Drive Sizes 1–2 in High Speed Range (4500–6000 RPM) | 197 |
| 11.2.1.9 | Mechanical Data for Drive Sizes 3–5 in High Speed Range (4500–6000 RPM) | 198 |
| 11.2.2 | Characteristic Data for DSD 520 Servo Drive | 199 |
| 11.2.3 | Characteristic Data for Power Supply Module (PSM 510) | 200 |
| 11.2.4 | Characteristic Data for Decentral Access Module (DAM 510) | 201 |
| 11.2.5 | Characteristic Data for Auxiliary Capacitors Module (ACM 510) | 202 |
| 11.2.6 | Characteristic Data for Expansion Module (EXM 510) | 202 |
| 11.3 | Dimensions | 202 |
| 11.3.1 | Dimensions of ISD 520 Servo Drive | 202 |
| 11.3.2 | Dimensions of DSD 520 Servo Drive | 205 |

| | | |
|----------|--|-----|
| 11.3.3 | Dimensions of Power Supply Module (PSM 510) | 206 |
| 11.3.4 | Dimensions of Decentral Access Module (DAM 510) | 207 |
| 11.3.5 | Dimensions of Auxiliary Capacitors Module (ACM 510) | 208 |
| 11.3.6 | Dimensions of Expansion Module (EXM 510) | 209 |
| 11.4 | Motor Overload Protection | 209 |
| 11.5 | Motor Overtemperature Protection | 209 |
| 11.6 | Allowed Forces on the ISD 520 Servo Drive Shaft | 210 |
| 11.7 | Connectors on the ISD 520/DSD 520 Servo Drives | 210 |
| 11.7.1 | X1 and X2 Hybrid Connectors | 210 |
| 11.7.2 | X3: I/O Connector (M12, 8 pole) | 211 |
| 11.7.3 | X4: I/O Connector (M12, 8 pole) | 212 |
| 11.7.4 | X5: LCP Connector (M8, 6 pole) | 213 |
| 11.8 | Connectors on the DSD 520 Servo Drives | 214 |
| 11.8.1 | Digital Motor Feedback Connector | 214 |
| 11.8.2 | Analog Motor Feedback Connector | 214 |
| 11.8.3 | Thermistor, Mechanical Brake, and HIPERFACE® DSL Connector | 215 |
| 11.8.4 | Motor Phase Connector | 215 |
| 11.8.4.1 | Cable Cross-sections for the Motor Phases | 216 |
| 11.9 | Connectors on the System Modules | 216 |
| 11.9.1 | Backlink Connector | 216 |
| 11.9.2 | Brake Connectors | 217 |
| 11.9.2.1 | Brake Resistor Connector on PSM 510 | 217 |
| 11.9.3 | Ethernet Connectors | 217 |
| 11.9.3.1 | Ethernet Connectors on PSM 510 and ACM 510 | 218 |
| 11.9.3.2 | Ethernet Connectors on DAM 510 | 218 |
| 11.9.4 | I/O Connectors | 218 |
| 11.9.4.1 | I/O Connector on PSM 510/ACM 510 | 218 |
| 11.9.5 | UAUX Connector | 219 |
| 11.9.5.1 | 24/48 V Cable Cross-sections for PSM 510 | 220 |
| 11.9.6 | LCP Connector (M8, 6 Pole) | 220 |
| 11.9.7 | AC Mains Connector | 221 |
| 11.9.7.1 | Mains Cable Cross-sections for PSM 510 | 221 |
| 11.9.8 | Relay Connector | 222 |
| 11.9.8.1 | Relay Connector on PSM 510/ACM 510 | 222 |
| 11.9.9 | STO Connectors | 222 |
| 11.9.9.1 | STO Connectors on PSM 510 | 222 |

| | |
|---|-----|
| 11.9.9.2 STO Connectors on DAM 510 | 223 |
| 11.9.10 UDC Connector | 225 |
| 11.9.11 AUX Connector | 226 |
| 11.9.12 External Encoder Connectors | 227 |
| 11.9.13 Expansion Module Connector | 228 |
| 11.9.13.1 Cable Cross-sections for EXM 510 | 228 |
| 11.10 Safe Digital Inputs and Outputs | 228 |
| 11.11 General Specifications and Environmental Data | 229 |
| 11.11.1 ISD 520/DSD 520 Servo Drive | 229 |
| 11.11.2 System Modules | 230 |
| 11.12 Protection Ratings | 231 |
| 11.12.1 Protection Ratings for ISD 520 Servo Drive | 231 |
| 11.12.2 Protection Ratings for DSD 520 Servo Drive | 231 |
| 11.13 Cables | 232 |
| 11.13.1 Hybrid Cable PE | 232 |
| 11.14 Storage | 232 |

1 Introduction

1.1 Purpose of the Operating Guide

The purpose of this operating guide is to describe the VLT® Servo Drive System ISD 520/DSD 520.

This operating guide contains information about:

- Installation
- Commissioning
- Programming
- Operation
- Troubleshooting
- Service and maintenance

This operating guide is intended for use by qualified personnel. Read the operating guide in full to use the servo system safely and professionally, and pay particular attention to the safety instructions and general warnings. Always keep this operating guide available with the servo system.

Compliance with the information in the guide is a prerequisite for:

- Trouble-free operation
- Recognition of product liability claims

Therefore, read this operating guide before working with the ISD 520/DSD 520 system.

1.2 Additional Resources

Table 1: Additional Resources

| Guide | Description |
|--|--|
| VLT® Servo Drive System ISD 520, DSD 520, MSD 520 (VLT® FlexMotion™) Design Guide | Information about the setup of the ISD 520/DSD 520 servo system and detailed technical data. |
| VLT® Servo Drive System ISD 520, DSD 520, MSD 520 (VLT® FlexMotion™) Programming Guide | Information about the programming of the ISD 520, DSD 520, and MSD 520 servo systems. |
| Advanced Functional Safety for VLT® FlexMotion™ Operating Guide | Information about operating the advanced functional safety option for VLT® FlexMotion™. |

1.3 Copyright

VLT® and ISD® are Danfoss registered trademarks.

1.4 Document Version

The original language of this guide is English.



| Version | Remarks |
|----------------------------|--|
| AQ441543733781, version 02 | <p>Editorial change: Table of content. Added, 6.16 Motion Library.</p> <p>Editorial change: 2.1 Safety Symbols.</p> <p>Updated: 3.2.3 ISD 520 Servo Drive Types.</p> <p>Updated: 11.2.1 Characteristic Data .</p> <p>Updated: 11.7.2 and 11.7.3 Connectors on the ISD 520/DSD 520 Servo Drives.</p> <p>New style sheet, text compressed (Reduced pages).</p> |

1.5 Approvals and Certifications

Table 2: Product and System Approvals and Certifications

| Certification | Description |
|----------------------------------|--|
| IEC/EN 61800-3 | Adjustable speed electrical power drive systems. Part 3: EMC requirements and specific test methods. |
| IEC/EN 61800-5-1 | Adjustable speed electrical power drive systems. Part 5-1: Safety requirements - Electrical, thermal, and energy. |
| IEC/EN 61800-5-2 | Adjustable speed electrical power drive systems. Part 5-2: Safety requirements - Functional. |
| IEC/EN 61508-1 | Functional safety of electrical/electronic/programmable electronic safety-related systems. Part 1: General requirements. |
| IEC/EN 61508-2 | Functional safety of electrical/electronic/programmable electronic safety-related systems. Part 2: Requirements for electrical/electronic/programmable electronic safety-related systems. |
| EN ISO 13849-1 | Safety of machinery - Safety-related parts of control systems. Part 1: General principles for design. |
| EN ISO 13849-2 | Safety of machinery - Safety-related parts of control systems. Part 2: Validation. |
| IEC/EN 60529 | Degrees of protection provided by enclosures (IP Code). |
| UL 61800-5-1 | Adjustable speed electrical power drive systems. Part 5-1: Safety requirements - Electrical, thermal, and energy. |
| CSA C22.2 No. 274 | Standard specifying requirements for adjustable speed drives with regard to electrical, thermal, and energy safety considerations. |
| CE | |
| 2014/30/EU | Electromagnetic Compatibility (EMC) Directive. |
| 2014/35/EU | Low Voltage Directive (LVD). |
| 2011/65/EU amended (EU) 2015/863 | Restriction of Hazardous Substances (RoHS). |
| 2006/42/EC | Machinery Directive (MD). |
| Ethernet POWERLINK® | Ethernet-based fieldbus system. |
| Ethernet PROFINET® | Ethernet-based fieldbus system. |

Table 2: Product and System Approvals and Certifications - (continued)

| Certification | Description |
|--|--|
| Ethernet PROFI-safe® | Safety profile for sending safety-critical data via PROFINET. |
| Ethernet EtherCAT®  | Ethernet-based fieldbus system. EtherCAT® is a registered trademark and patented technology, licensed by Beckhoff Automation GmbH, Germany. |
| Safety over EtherCAT® (FSoE) Safety over  | Safety profile for sending safety-critical data over EtherCAT®. Safety over EtherCAT® is a registered trademark and patented technology, licensed by Beckhoff Automation GmbH, Germany. |
| PLCopen® | Technical specification. Function blocks for motion control (formerly Part 1 and Part 2) Version 2.0 March 17, 2011. |

1.6 Firmware Updates

Updates to the firmware, VLT® Servo Toolbox software, and PLC libraries may be available. When updates are available, they can be downloaded from the Danfoss website (<http://drives.danfoss.com>).

Use the VLT® Servo Toolbox software or the PLC libraries to install the firmware on the servo drives or on the PSM 510 and DAM 510.

1.7 Terminology

Table 3: Terminology

| Term | Description |
|---------------------------|--|
| ACM 510 | Auxiliary Capacitors Module |
| DAM 510 | Decentral Access Module that connects the decentral servo drives (ISD 520 and DSD 520) to the servo system via a hybrid cable. |
| DSD 520 | Decentral Servo Drive |
| DSD 520 system components | Includes DSD 520 servo drives, PSM 510, DAM 510, and the optional ACM 510 and EXM 510. |
| EXM 510 | Expansion module for splitting system modules between 2 control cabinets. |
| Feed-in cable | Hybrid cable for connection from the DAM 510 to the 1st decentral drive. |
| ISD 520 | Integrated Servo Drive |
| ISD 520 system components | Includes ISD 520 servo drives, PSM 510, DAM 510, and the optional ACM 510 and EXM 510. |
| LCP | Local control panel |
| Loop cable | Hybrid cable for connecting servo drives in daisy-chain format. |
| PLC | Programmable Logic Controller (external device for controlling the servo system). |
| PSM 510 | Power Supply Module that generates a 565–680 V DC supply. |
| System modules | Includes PSM 510, DAM 510, and the optional ACM 510 and EXM 510. |

Table 3: Terminology - (continued)

| Term | Description |
|---------------|---------------------------|
| V_{IN} PSM | Input of PSM 510 (V AC). |
| V_{OUT} PSM | Output of PSM 510 (V DC). |

2 Safety

2.1 Safety Symbols

The following symbols are used in Danfoss documentation.



| |
|---|
|  DANGER |
| Indicates a hazardous situation which, if not avoided, will result in death or serious injury. |

| |
|--|
|  WARNING |
| Indicates a hazardous situation which, if not avoided, could result in death or serious injury. |

| |
|--|
|  CAUTION |
| Indicates a hazardous situation which, if not avoided, could result in minor or moderate injury. |

| |
|---|
| NOTICE |
| Indicates information considered important, but not hazard-related (for example, messages relating to property damage). |

The guide also includes ISO warning symbols related to hot surfaces and burn hazard, high voltage and electric shock, and referring to the instructions.

| | |
|---|--|
|  | ISO warning symbol for hot surfaces and burn hazard |
|  | ISO warning symbol for high voltage and electric shock |
|  | ISO action symbol for referring to the instructions |

2.2 Important Safety Warnings

The following safety instructions and precautions relate to the ISD 520/DSD 520 servo system. Read the safety instructions carefully before starting to work in any way with the servo system or its components. Pay particular attention to the safety instructions in the relevant sections of this guide.

| |
|--|
|  WARNING |
| <p>HAZARDOUS SITUATION</p> <p>If the servo system components, or the bus lines are incorrectly connected, there is a risk of death, serious injury, or damage to the unit.</p> <ul style="list-style-type: none"> • Always comply with the instructions in this guide and national and local safety regulations. |

WARNING



HIGH VOLTAGE

The servo system contains components that operate at high voltage when connected to the electrical supply network. Not all components have indicators that indicate the presence of mains supply. Incorrect installation, commissioning, or maintenance may lead to death or serious injury.

- Installation, commissioning, and maintenance may only be performed by qualified personnel.

WARNING



DISCHARGE TIME

The servo system contains DC-link capacitors that remain charged for some time after the mains supply is switched off at the Power Supply Module (PSM 510). Failure to wait the specified time after power has been removed before performing service or repair work could result in death or serious injury.

- To avoid electric shock, fully disconnect the Power Supply Module (PSM 510) from the mains and wait for the capacitors to fully discharge before carrying out any maintenance work on the servo system or replacing components.

Minimum waiting time (minutes)

15

DANGER



RISQUE DU CHOC ÉLECTRIQUE

Une tension dangereuse peut être présentée jusqu'à 15 min après avoir coupé l'alimentation.

WARNING



LEAKAGE/GROUNDING CURRENT HAZARD

Leakage/grounding currents are >3.5 mA. Improper grounding of the ISD 520/DSD 520 servo drives and the system modules may result in death or serious injury.

- For reasons of operator safety, use a certified electrical installer to ground the system correctly in accordance with the applicable local and national electrical standards and directives, and the instructions in this guide.

WARNING

UNINTENDED START

The servo system contains servo drives, the PSM 510, and DAM 510 that are connected to the electrical supply network and can start running at any time. This may be caused by a fieldbus command, a reference signal, or clearing a fault condition. Servo drives and all connected devices must be in good operating condition. A deficient operating condition may lead to death, serious injury, damage to equipment, or other material damage when the unit is connected to the electrical supply network.

- Take suitable measures to prevent unintended starts.

WARNING**UNINTENDED MOVEMENT**

Unintended movement may occur immediately when parameter changes are carried out, which may result in death, serious injury, or damage to equipment.

- When changing parameters, take suitable measures to ensure that unintended movement cannot pose any danger.

CAUTION**DANGER OF BURNS**

The surface of the servo drives can reach high temperatures of over 90 °C during operation.

- Do not touch the servo drives until they have cooled down.

CAUTION**CONNECTING/DISCONNECTING HYBRID CABLES**

Never connect or disconnect the hybrid cable to or from the servo drives when the servo system is connected to mains or auxiliary supply, or when voltage is still present. Doing so damages the electronic circuitry. Ensure that the mains supply is disconnected and the required discharge time for the DC-link capacitors has elapsed before disconnecting or connecting the hybrid cables to the PSM 510.

- To avoid electrical shock, fully disconnect the PSM 510 from the mains and wait for the discharge time to elapse before disconnecting or connecting the hybrid cables or disconnecting cables from the PSM 510.

NOTICE**RCD COMPATIBILITY**

The servo system contains components that can cause a DC current in the protective earthing conductor, which may result in malfunction in any devices connected to the system.

- Where a residual current-operated protective (RCD) or monitoring (RCM) device is used for protection if there is direct or indirect contact, use a type B RCD or RCM device on the supply side of the system components.

2.3 Safety Instructions and Precautions

Compliance with the safety instructions and precautions is necessary at all times.

- Orderly and proper transport, storage, fitting, and installation, as well as careful operation and maintenance, are essential for the trouble-free and safe operation of the servo system and its components.
- Only suitably trained and qualified personnel may work on the servo system and its components or in its vicinity.
- Only use accessories and spare parts approved by Danfoss.
- Comply with the specified ambient conditions.
- The information in this guide about the use of available components is provided solely by way of examples of applications and suggestions.
- The plant engineer or system engineer is personally responsible for checking the suitability of the supplied components and the information provided in this guide for the specific application concerned:
 - For compliance with the safety regulations and standards relevant to the specific application.
 - For implementing the necessary measures, changes, and extensions.

- Commissioning the servo system or its components is not allowed until it has been ascertained that the machine, system, or plant in which they are installed conforms to the statutory provisions, safety regulations, and standards that apply to the application in the country of use.
- Operation is only allowed in compliance with the national EMC regulations for the application concerned.
- Compliance with the limit values specified by national regulations is the responsibility of the producer of the plant, system, or machine.
- Compliance with the specifications, connection conditions, and installation conditions in this guide is mandatory.
- The safety regulations and safety provisions of the country in which the equipment is used must be observed.
- To protect the user against electric shock and to protect the servo system against overload, protective grounding is obligatory and must be performed in accordance with local and national regulations.

2.4 Operational Safety

- Safety-related applications are only allowed if they are explicitly and unambiguously mentioned in this guide.
- All applications that can cause hazards to people or damage to property are safety-related applications.
- The stop functions implemented in the software of the PLC do not interrupt the mains supply to the Power Supply Module (PSM 510). Therefore, they must not be used for electrical safety for the servo system.
- The servo system can be brought to a stop by a software command or a zero speed setpoint, however DC voltage remains present on the servo drives and/or mains voltage in the PSM 510. Also, when the system is stopped, it may start up again on its own if the circuitry is defective or after the elimination of a temporary overload, a problem with the supply voltage, or a problem with the system. If personal safety considerations (for example, risk of personal injury caused by contact with moving machine parts after an unintended start) make it necessary to ensure that an unintended start cannot occur, these stop functions are not sufficient. In this case, ensure that the servo system is detached from the mains network, and prevent unintended motor starting, for example, by using the safe torque off (STO) function.
- The servo system may start running unintentionally during parameter configuration or programming. If this poses a risk to personal safety (for example, risk of personal injury due to contact with moving machine parts), prevent unintended motor starting, for example by using the safe torque off (STO) function, or by safe disconnection of the servo drives.
- In addition to the L1, L2, and L3 supply voltage inputs on the PSM 510, the servo system has other supply voltage inputs, including external auxiliary voltage. Before commencing repair work, check that all supply voltage inputs have been switched off and that the necessary discharge time for the DC-link capacitors has elapsed.

2.5 Qualified Personnel

Installation, commissioning, and maintenance may only be carried out by qualified personnel. For the purposes of this guide and the safety instructions in this guide, qualified personnel are trained personnel who are authorized to fit, install, commission, ground, and label equipment, systems, and circuits in accordance with the standards for safety technology and who are familiar with the safety concepts of automation engineering.

Also, the personnel must be familiar with all the instructions and safety measures described in this guide. They must have suitable safety equipment and be trained in first aid.

2.6 Due Diligence

The operator and/or fabricator must ensure that:

- The servo system and its components are used only as intended.
- The components are operated only in a perfect operational condition.
- The operating instructions are always available near the servo system in complete and readable form.
- The servo system and its components are fitted, installed, commissioned, and maintained only by adequately qualified and authorized personnel.

- These personnel are regularly instructed on all relevant matters of occupational safety and environmental protection, as well as the contents of the operating instructions and the instructions it contains.
- The product markings and identification markings applied to the components, as well as safety and warning instructions, are not removed and are always kept in a legible condition.
- The national and international regulations regarding the control of machinery and equipment, that are applicable at the place of use of the servo system, are complied with.
- The users always have all current information relevant to their interests about the servo system and its use and operation.

2.7 Intended Use

The components of the servo system are intended to be installed in machines used in industrial environments in accordance with local laws and standards.

NOTICE

- In a domestic environment, this product may cause radio interferences, in which case supplementary mitigation measures may be required.

To ensure that the product is used as intended, the following conditions must be fulfilled before use:

- Everyone who uses Danfoss products in any manner must read and understand the corresponding safety regulations and the description of the intended use.
- Do not alter hardware from its original state.
- Do not reverse-engineer software products or alter their source code.
- Do not install or operate damaged or faulty products.
- Ensure that the products are installed in conformance with the regulations mentioned in the documentation.
- Observe any specified maintenance and service intervals.
- Comply with all protective measures.
- Only fit or install the components described in this operating guide. Third-party devices and equipment may be used only in consultation with Danfoss.

2.7.1 Prohibited Application Areas

The servo system **may not** be used in the following application areas:

- Areas with potentially explosive atmospheres.
- Mobile or portable systems.
- Floating or airborne systems.
- Inhabited facilities.
- Sites where radioactive materials are present.
- Areas with extreme temperature variations or in which the maximum rated temperatures may be exceeded.
- Under water.

2.8 Foreseeable Misuse

Any use not expressly approved by Danfoss constitutes misuse. This also applies to failure to comply with the specified operating conditions and applications. Danfoss assumes no liability of any sort for damage attributable to improper use.

2.9 Service and Support

Contact the local service representative for service and support.

3 System Description

3.1 Overview of the ISD 520/DSD 520 Servo System

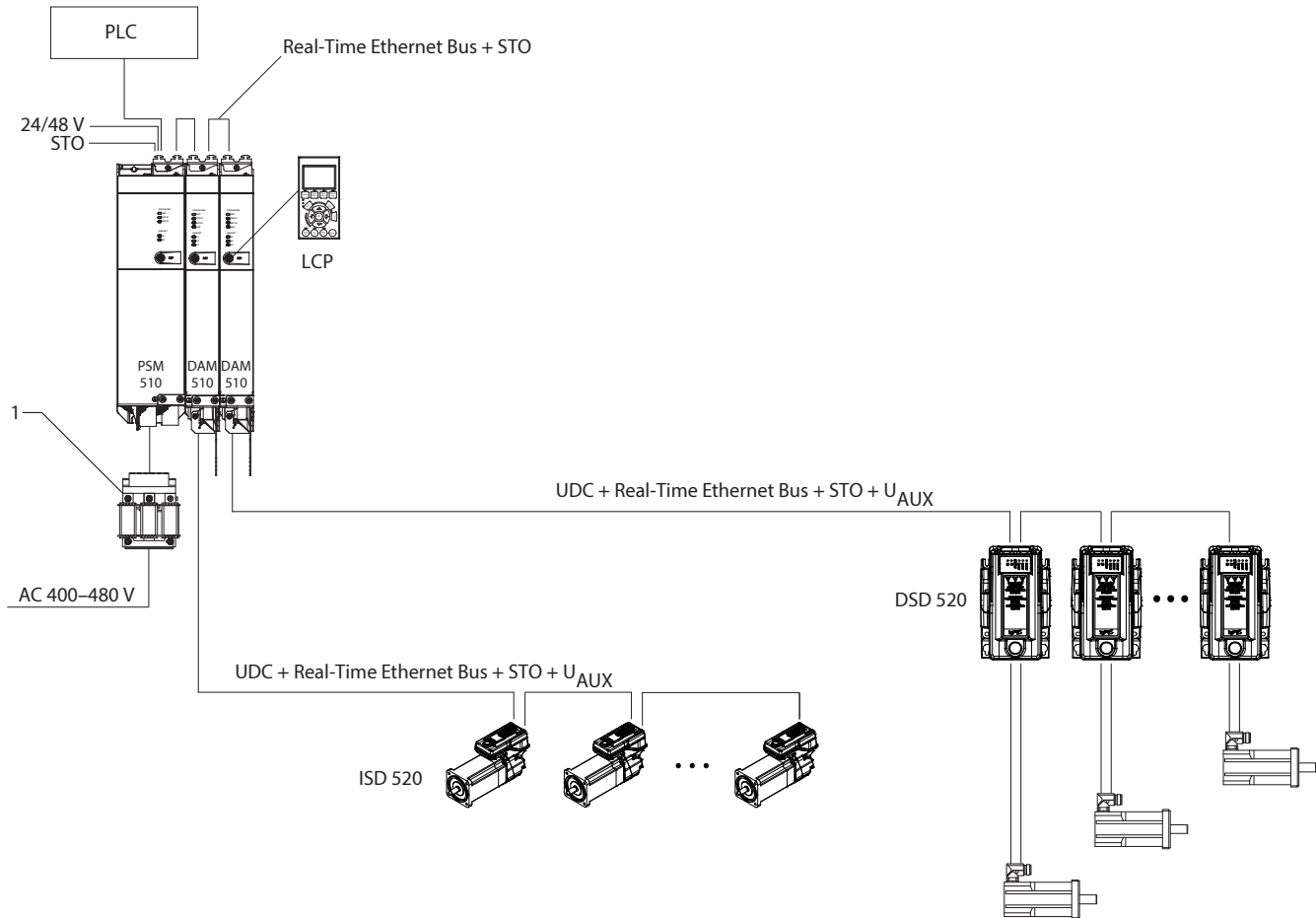

e30b1082.10

Figure 1: Overview of the ISD 520/DSD 520 System

1 AC line choke

The VLT® Servo Drive System ISD 520/DSD 520 is a high-performance decentral servo motion solution. In this decentral system, the ISD 520/DSD 520 servo drives are operated in a DC group, controlled by a PLC, and supplied by PSM 510 and DAM 510. The decentralization of the drive unit offers benefits in mounting, installation, and operation.

Hybrid cables are used to connect the ISD 520/DSD 520 servo drives, making installation fast and simple. These hybrid cables contain the DC-link supply, the Real-Time Ethernet, U_{AUX} , and STO signals.

The ISD 520/DSD 520 system is designed to accommodate various servo drives and consists of:

- VLT® Integrated Servo Drive ISD 520
- VLT® Decentral Servo Drive DSD 520
- Power Supply Module (PSM 510)
- Decentral Access Module (DAM 510)
- Auxiliary Capacitors Module (ACM 510), optional
- Expansion Module (EXM 510), optional
- Cabling infrastructure
- Blind caps

- Software
 - Firmware for the servo drive
 - Firmware for the PSM 510, DAM 510, and ACM 510
 - Pc software tool: VLT®Servo Toolbox
 - PLC libraries
 - Danfoss Motion library for ISD 520/DSD 520 system for AutomationStudio®.
 - Danfoss Motion library for ISD 520/DSD 520 system for TwinCAT 3.
 - Danfoss Motion library for ISD 520/DSD 520 system for TiA Portal.

The system modules PSM 510, DAM 510, and ACM 510 are mounted to a backplate located in the control cabinet. DC link and the control voltage supply are integrated in the backplate. The 'click and lock' backplate concept offers easy mounting and installation.

The ISD 520 servo drives are self-contained distributed drives, whereby the drive electronics are housed together with the motor in the same casing. The DSD 520 servo drives are decentral servo drives for mounting close to the servo motor.

Options available for ISD 520/DSD 520:

- Standard I/O board
- VLT® FlexSafety™ (FS Control board)
- Safe I/O board (only in combination with FS Control board)

The motion control is integrated into the servo drive so that the motion sequences can take place independently. This reduces the required computing power of the central PLC and offers a highly flexible drive concept. Danfoss offers libraries for various IEC 61131-3 programmable PLCs. Due to the standardized and certified fieldbus interfaces of the devices, any PLC with an EtherCAT® master functionality, or Ethernet POWERLINK® or PROFINET® managing node functionality according to the standards can be used.

NOTICE

- The ISD 520/DSD 520 servo drives cannot be used in servo systems from other manufacturers without changing the cabling infrastructure.
- Drives from other manufacturers cannot be used in the ISD 520/DSD 520 servo system.
- Only the components described in this guide may be fitted or installed. Third-party devices and equipment may be used only in consultation with Danfoss.
- For security reasons, do not connect the ISD 520/DSD 520 servo drive to the internet.
- Only configure the ISD 520/DSD 520 using the specified HMI or the VLT® Servo Toolbox software.
- Contact Danfoss for further information.

3.2 VLT® Integrated Servo Drive ISD 520

3.2.1 Overview of the ISD 520 Servo Drive

ISD is the abbreviation of integrated servo drive, which is a compact drive with an integrated permanent magnet synchronous motor (PMSM). This means that the entire power drive system consisting of motor, position sensor, mechanical brake, and also power and control electronics is integrated into 1 housing. Additional circuits, such as low voltage supply, bus drivers, and functional safety are implemented within the servo drive electronics. All ISD 520 servo drives have 2 hybrid connectors (M23) that connect power and communication signals from a hybrid cable. There are 3 additional interfaces for external encoder or I/Os, fieldbus devices, and for the local control panel (LCP) to be connected directly. Indicator lights (LEDs) on the top of the ISD 520 servo drive show the current status. Data transfer takes place via Real-Time Ethernet.

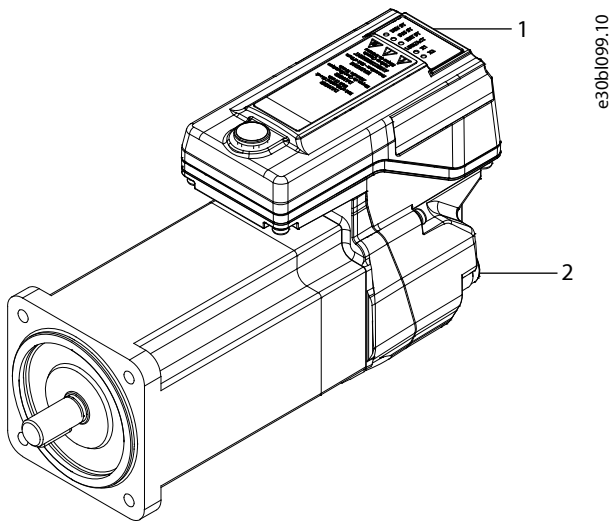

Figure 2: Overview of the ISD 520 Servo Drive

| | | | |
|---|-----------------------------------|---|------------|
| 1 | Operating indicator lights (LEDs) | 2 | Connectors |
|---|-----------------------------------|---|------------|

3.2.2 Motor and Flange Sizes

Table 4: Motor and Flange Sizes

| Enclosure size | E0 | | E1 | | | | | E2 | | | | | |
|-------------------|------|------|------|-----|-----|-----|-----|-----|-----|------|------|------|------|
| | 1 | 2 | 1 | 2 | | | 3 | 4 | | 5 | | | |
| Drive size | 1.5 | 2.5 | 1.5 | 2.5 | 3.5 | 4.0 | 5.0 | 6.5 | 9.0 | 12.0 | 14.0 | 16.5 | 19.0 |
| Rated torque [Nm] | 1.5 | 2.5 | 1.5 | 2.5 | 3.5 | 4.0 | 5.0 | 6.5 | 9.0 | 12.0 | 14.0 | 16.5 | 19.0 |
| Flange size [mm] | 70 | 87 | 70 | 91 | | | 100 | | 116 | | 142 | | |
| Shaft size [mm] | 11 | 19 | 11 | 14 | | 19 | | | 24 | | | 32 | |
| Rated speed [nN] | 3000 | 2000 | 3000 | | | | | | | 2200 | | | |

3.2.3 ISD 520 Servo Drive Types

NOTICE

- The type code defines the specification of the ISD 520 servo drive included in the delivery. It is shown on the product label and the package label.
- The type code is made of standard codes and plus codes. Each part of the type code corresponds to the data in the order.
- The Drive Configurator shows the valid configuration of servo drive variants.
- Only selected options are visible in the type code. Standard characteristics do not appear.

Table 5: Type Code for ISD 520 Servo Drive

| 1 | 2 | 3 | 4 | + | + | + | + | + | + | + | + | + | + | + | + | + | + |
|---------------|---------------|---|-------------------------------|-------------------|--------------|-------------------------|------------------------|-------------------------|------------------|-------------|------------------|---------------|-------------|------|-------------|------------|------------------|
| Product group | Mains voltage | Torque level (rated) | Communication interface | Functional Safety | Option board | Technical documentation | Documentation language | Customer-specific label | Mechanical brake | Motor shaft | Motor shaft size | Feedback type | Flange size | Gear | Rated speed | Shaft seal | Shipping package |
| ISD-520 | D6 | -01T5 -02T0 -02T5 -03T0 -03T5 -04T0 -04T5 -05T0 -06T5 -08T0 -08T5 -09T0 -12T0 -14T0 -16T5 | See Table 6 . | | | | | | | | | | | | | | |

Table 6: Legend to Type Code

| 1 | Product group | + | Technical documentation | + | Flange size (continued) |
|---------|---------------------------------|-------|-----------------------------------|--------|-----------------------------------|
| ISD-520 | VLT® Integrated Servo Drive 520 | +EGXX | None (standard) | +FG100 | 100 mm |
| 2 | Mains voltage | +EGIN | Installation guide | +FG116 | 116 mm |
| D6 | 600 V DC | + | Documentation language | +FG142 | 142 mm |
| 3 | Torque level (rated) | +EHXX | Multilanguage (standard) | + | Gear |
| -01T5 | 1.5 Nm | + | Customer-specific label | +FHXX | Without gear (standard) |
| -02T0 | 2.0 Nm | | | | |
| -02T5 | 2.5 Nm | +EJXX | None (standard) | + | Rated speed |
| -03T0 | 3.0 Nm | | | | |
| -03T5 | 3.5 Nm | + | Mechanical brake | +FN04 | 400 RPM |
| -04T0 | 4.0 Nm | +FAXX | Without holding brake (standard) | +FN10 | 1000 RPM |
| -04T5 | 4.5 Nm | +FAHB | With holding brake | +FN20 | 2000 RPM |
| -05T0 | 5.0 Nm | + | Motor shaft | +FN22 | 2200 RPM |
| -06T5 | 6.5 Nm | +FCSS | Smooth shaft | +FN30 | 3000 RPM |
| -08T0 | 8.0 Nm | | | | |
| -08T5 | 8.5 Nm | +FCKS | Fitted key | +FN45 | 4500 RPM |
| -09T0 | 9.0 Nm | | | | |
| -12T0 | 12.0 Nm | + | Motor shaft size | +FN60 | 6000 RPM |
| -14T0 | 14.0 Nm | +FD11 | 11 mm | + | Shaft seal |
| -16T5 | 16.5 Nm | +FD14 | 14 mm | +FSXX | Without shaft seal |
| 4 | Communication interface | +FD19 | 19 mm | +FSSS | With shaft seal |
| PL | Ethernet POWER-LINK® | +FD24 | 24 mm | + | Shipping package |
| EC | EtherCAT® | +FD32 | 32 mm | +TACB | Individually packaged (standard) |
| PN | PROFINET® | + | Feedback type | +TAMP | All products shipped in 1 package |
| + | Functional Safety | +FFS0 | Single-turn 17-bit BISS-C | | |
| +BEF1 | Hard-wired STO (standard) | +FFS1 | Single-turn 17-bit HIPERFACE® DSL | | |
| +BEFS | VLT® FlexSafety™ over fieldbus | +FFM1 | Multi-turn 17-bit HIPERFACE® DSL | | |

Table 6: Legend to Type Code - (continued)

| | | | | | |
|-------|---------------------------------|--------|---|--|--|
| + | Option board | +FFM3 | Safety multi-turn 20-bit HIPERFACE® DSL | | |
| +CTXX | Without option board (standard) | + | Flange size | | |
| +CTIO | Standard I/O option board | +FG070 | 70 mm | | |
| +CTSO | Safe I/O option board | +FG087 | 87 mm | | |
| | | +FG091 | 91 mm | | |

3.2.4 Motor Components

3.2.4.1 Shaft

The shaft transfers the motor force (torque) to the machine coupled to the shaft. The shaft material is C45+C or equivalent according to EN 10277-2. The ISD 520 servo drives are sealed by a shaft seal to achieve IP65 on the A-side of the motor (see [11.12.1 Protection Ratings for ISD 520 Servo Drive](#)).

3.2.4.2 Brake (Optional)

The optional mechanical holding brake is designed as a single-disc brake. The emergency stop function can be initiated at most once every 3 minutes and up to 2000 times in total, depending on the load.

The brake operates as a holding brake according to the fail-safe principle closed when no current is present. It is powered from the DC auxiliary supply. This enables low-backlash load holding when no current is present.

If a mechanical brake is connected, always supply the servo system with 48 V auxiliary voltage.

See the tables in [11.2.1 Characteristic Data for ISD 520 Servo Drive](#) for brake weight, inertia, power, and holding torque.

| NOTICE | |
|--|--|
| <ul style="list-style-type: none"> Do not misuse the holding brake as a working brake because this causes increased wear, resulting in premature failure. Using ISD 520 servo drives with brakes can reduce the number of drives allowed, depending on the total length of each hybrid line. | |

3.2.4.3 Cooling

The ISD 520 servo drives are self-cooling. Cooling (heat dispersal) is primarily via the flange, with a small amount dispersed by the housing.

3.2.4.4 Thermal Protection

Thermal sensors monitor the maximum allowable temperature of the motor winding and switch the motor off if the limit of 140 °C is exceeded. Thermal sensors are also present in the drive to protect the electronics against overtemperature. An error message is sent via Real-Time Ethernet to the higher-level PLC and is also shown on the LCP.

3.2.4.5 Built-in Feedback Devices

The built-in feedback device measures the rotor position.

There are 3 feedback variants available:

- BiSS-C 17-bit single-turn encoder

- HIPERFACE® DSL 17-bit encoder, single-turn or multi-turn
- HIPERFACE® DSL 22-bit encoder, single-turn or multi-turn

Table 7: Built-in Feedback Devices

| Data/type | Single-turn encoder | Single-turn encoder | Multi-turn encoder | Single-turn encoder | Multi-turn encoder |
|------------|---------------------|---------------------|---------------------|---------------------|---------------------|
| Signal | Biss-C | HIPERFACE® DSL | HIPERFACE® DSL | HIPERFACE® DSL | HIPERFACE® DSL |
| Accuracy | ±6 arcmin | ±6 arcmin | ±6 arcmin | ±1.6 arcmin | ±1.6 arcmin |
| Resolution | 17 bit | 17 bit | 17 bit | 20 bit | 20 bit |
| Multiturn | No | No | Yes, -4096 (12 bit) | No | Yes, -4096 (12 bit) |
| Safety | No | No | No | Yes | Yes |

3.2.5 Drive Components

3.2.5.1 Connectors on the ISD 520 Servo Drives

There are 5 connectors on the ISD 520 servo drives.

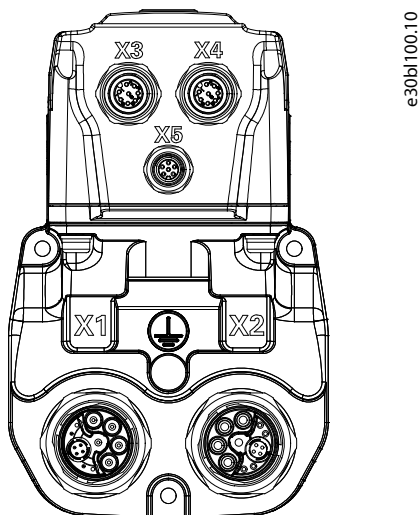

Figure 3: Connectors on the ISD 520 Servo Drive

Table 8: Connectors on the ISD 520 Servo Drive

| Connector | Description |
|-----------|--|
| X1 | M23 connector for feed-in or loop hybrid cable input |
| X2 | M23 connector for loop hybrid cable output or fieldbus extension |
| X3 | M12 connector for Safe/Standard I/O (channel A) |
| X4 | M12 connector for Safe/Standard I/O (channel B) |
| X5 | M8 connector for LCP cable (shielded) |

3.3 VLT® Decentral Servo Drive DSD 520

3.3.1 Overview of the DSD 520 Servo Drive

DSD is the abbreviation of decentral servo drive, which is a servo drive for mounting close to the servo motor. In this way, the servo motor has no impact to the DSD 520 servo drive from a thermal point of view.

The DSD 520 servo drive extends the selection of a decentral servo drive concept. It delivers rated power up to 3 kW and can be used with a wide range of permanent magnet servo motors and motor feedback encoders.

Indicator lights (LEDs) on the top of the DSD 520 servo drive show the current status. Data transfer takes place via Real-Time Ethernet.

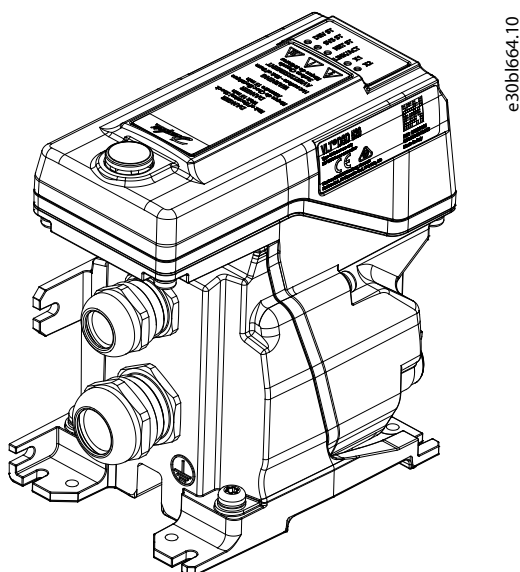

Figure 4: Overview of the ISD 520 Servo Drive

3.3.2 DSD 520 Servo Drive Types

NOTICE

- The type code defines the specification of the DSD 520 servo drive included in the delivery. It is shown on the product label and the package label.
- The type code is made of standard codes and plus codes. Each part of the type code corresponds to the data in the order.
- The Drive Configurator shows the valid configuration of servo drive variants.
- Only selected options are visible in the type code. Standard characteristics do not appear.

Table 9: Type Code for DSD 520 Servo Drive

| 1 | 2 | 3 | 4 | + | + | + | + | + | + | + | + |
|---------------|---------------|----------------|-------------------------|--------------------------------|--------------|-------------------------|------------------------|-------------------------|---------------|------------------|------------------|
| Product group | Mains voltage | Current rating | Communication interface | Functional safety | Option board | Technical documentation | Documentation language | Customer-specific label | Feedback type | Motor connection | Shipping package |
| DSD-520 | D6 | -05A0 | PL EC PN | See Table 10 . | | | | | | | |

Table 10: Legend to Type Code

| 1 | Product group | + | Option board | + | Motor connection |
|---------|--------------------------------|-------|--|-------|-----------------------------------|
| DSD-520 | VLT® Decentral Servo Drive 520 | +CTXX | Without option board (standard) | +FITS | Terminal box single connection |
| 2 | Mains voltage | +CTIO | Standard I/O option board | +FITD | Terminal box dual connection |
| D6 | 600 V DC | +CTSO | Safe I/O option board | +FIS3 | Single plug M23 connection |
| 3 | Current rating | + | Technical documentation | +FID3 | Dual plug M23 connection |
| -05A0 | 5.0 A | +EGXX | None (standard) | +FIBE | Terminal box bottom entry |
| 4 | Communication interface | +EGIN | Installation guide | + | Shipping package |
| PL | Ethernet POWER-LINK® | + | Documentation language | +TACB | Individually packaged (standard) |
| EC | EtherCAT® | +EHXX | Multilanguage (standard) | +TAMP | All products shipped in 1 package |
| PN | PROFINET® | + | Customer-specific label | | |
| + | Functional safety | +EJXX | None (standard) | | |
| +BEF1 | Hard-wired STO (standard) | + | Feedback type | | |
| +BEFS | VLT® FlexSafety™ over fieldbus | +FFMF | Multi-feedback interface (standard) ⁽¹⁾ | | |

1) Supported feedback systems: BiSS B/C, SSI, Resolver, HIPERFACE®, HIPERFACE® DSL, EnDat 2.1, EnDat 2.2

3.4 Power Supply Module (PSM 510)

3.4.1 Overview of PSM 510

PSM is the abbreviation for Power Supply Module. It is the power supply to the servo system. The PSM 510 supplies a DC power voltage and guarantees high-density output power. The DC link and 24/48 V DC are distributed via the backlink in the backplates to all system modules. The PSM 510 can be controlled via Ethernet-based fieldbus.

Indicator lights (LEDs) on the front of the PSM 510 show the operating status and warnings.

NOTICE

- The system modules are designed for use within a control cabinet. If the STO function is used, the cabinet must be rated at least IP54.
- The PSM 510 has a protection rating of IP20 according to IEC/EN 60529 (except connectors, which are IP00).
- The PSM 510 may be damaged if exposed to fluids.

All power cables are wired into the PSM 510, therefore at least 1 PSM 510 is required for each system.

The PSM 510 also performs service functions, such as voltage measuring, and is cooled by an internal fan.

The PSM 510 is available in 3 power sizes and delivers an output power of 10 kW, 20 kW, or 30 kW with 200% overload capacity for 3 s. To achieve an output power of up to 60 kW, 2 PSM 510 modules can be used in parallel.

An example type code for the PSM 510 is: MSD510PSM510F2P10C0D6E20PLSXXXXXXXXXXXXX.

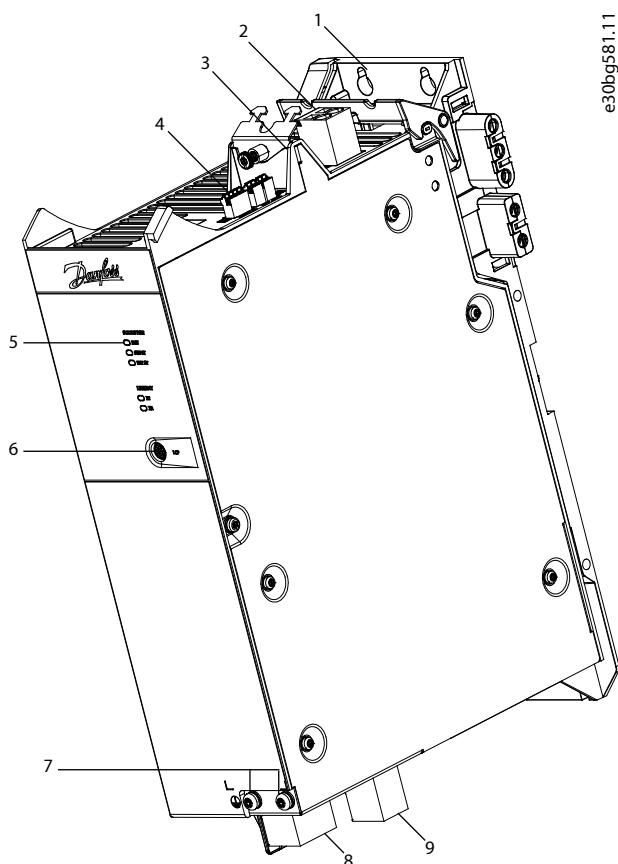

Figure 5: PSM 510

| | | | |
|---|--|---|---|
| 1 | Backplate | 2 | 24/48 V input connector |
| 3 | Cable relief and shielding | 4 | Connectors: I/O, STO, relay, and Ethernet |
| 5 | Operating indicator lights (LEDs) | 6 | LCP connector |
| 7 | PE screws | 8 | AC mains supply connector |
| 9 | Internal/external brake resistor connector | | |

3.5 Decentral Access Module (DAM 510)

3.5.1 Overview of DAM 510

DAM is the abbreviation for Decentral Access Module. The DAM 510 is a central interface/gateway to the decentral servo system. It is used to connect the Danfoss VLT® Integrated Servo Drives ISD 520 and VLT® Decentral Servo Drives DSD 520 to the servo system via a hybrid feed-in cable.

The DAM 510 supplies the decentral servo drives with DC link, U_{AUX} , STO, and the Ethernet-based fieldbus via the hybrid feed-in cable. The DAM 510 provides functions, such as:

- Overcurrent protection of the hybrid cable
- Overvoltage protection
- Charging circuit of the DC link

- External encoder connection
- DC-link capacitance buffer for the decentral servo drives

The DAM 510 can be controlled via Ethernet-based fieldbus.

Indicator lights (LEDs) on the front of the DAM 510 show the operating status and warnings.

NOTICE

- The system modules are designed for use within a control cabinet. If the STO function is used, the cabinet must be rated at least IP54.
- The DAM 510 has a protection rating of IP20 according to IEC/EN 60529 (except connectors, which are IP00).
- The DAM 510 can be damaged if exposed to fluids.

An example type code for the DAM 510 is: MSD510DAM510F1C015AD6E20PLSXXXXXXXXXXXXXX.

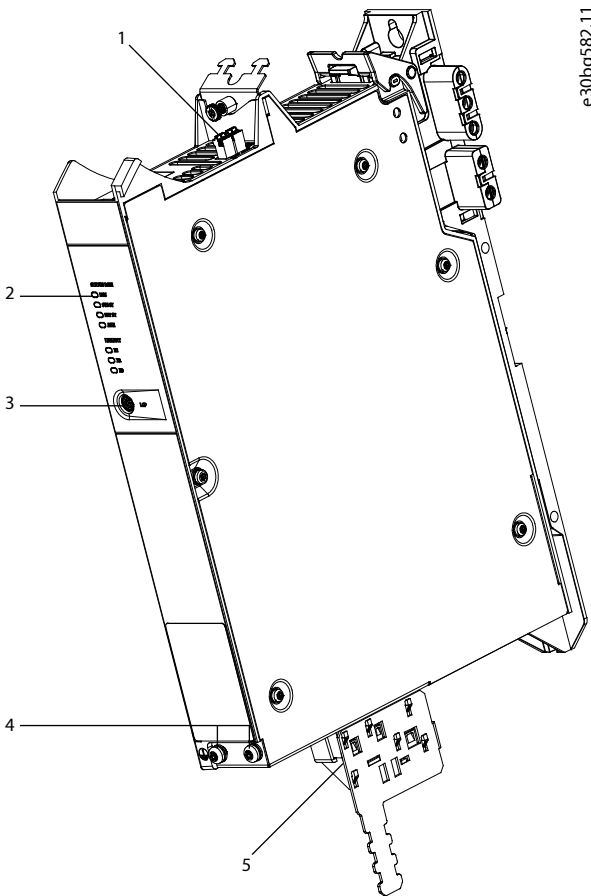

Figure 6: DAM 510

| | | | |
|---|---|---|-----------------------------------|
| 1 | Connectors: STO, Ethernet, and external encoder | 2 | Operating indicator lights (LEDs) |
| 3 | LCP connector | 4 | PE screws |
| 5 | Connectors: UDC, AUX, STO out, and Ethernet | | |

3.6 Auxiliary Capacitors Module (ACM 510)

3.6.1 Overview of ACM 510

ACM is the abbreviation for Auxiliary Capacitors Module. The ACM 510 can be connected to the Danfoss system to store energy, enabling a controlled machine stop in emergency situations.

NOTICE

- The system modules are designed for use within a control cabinet. If the STO function is used, the control cabinet must be rated at least IP54.
- The ACM 510 has a protection rating of IP20 according to IEC/EN 60529 (except connectors, which are IP00).
- The ACM 510 can be damaged if exposed to fluids.

An example type code for the ACM 510 is: MSD510ACM510F1E00C8D6E20PLSXXXXXXXXXXXXXX.

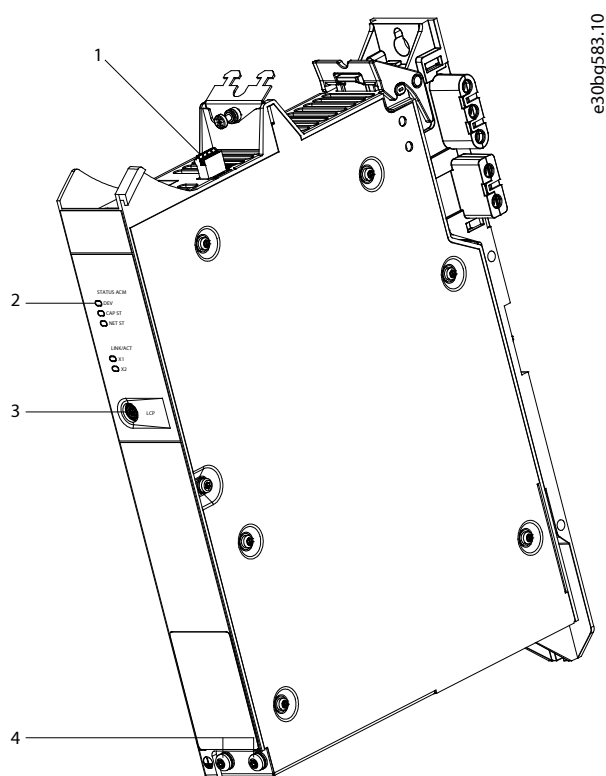

Figure 7: ACM 510

| | | | |
|---|--------------------------------------|---|-----------------------------------|
| 1 | Connectors: I/O, relay, and Ethernet | 2 | Operating indicator lights (LEDs) |
| 3 | LCP connector | 4 | PE screws |

3.7 Expansion Module (EXM 510)

The EXM 510 supports modular machine setup by splitting the system modules into 2 control cabinets. The maximum length of the cable between the EXM 510 modules is 5 m.

See [5.15 Connecting the Expansion Module EXM 510](#) for further information.

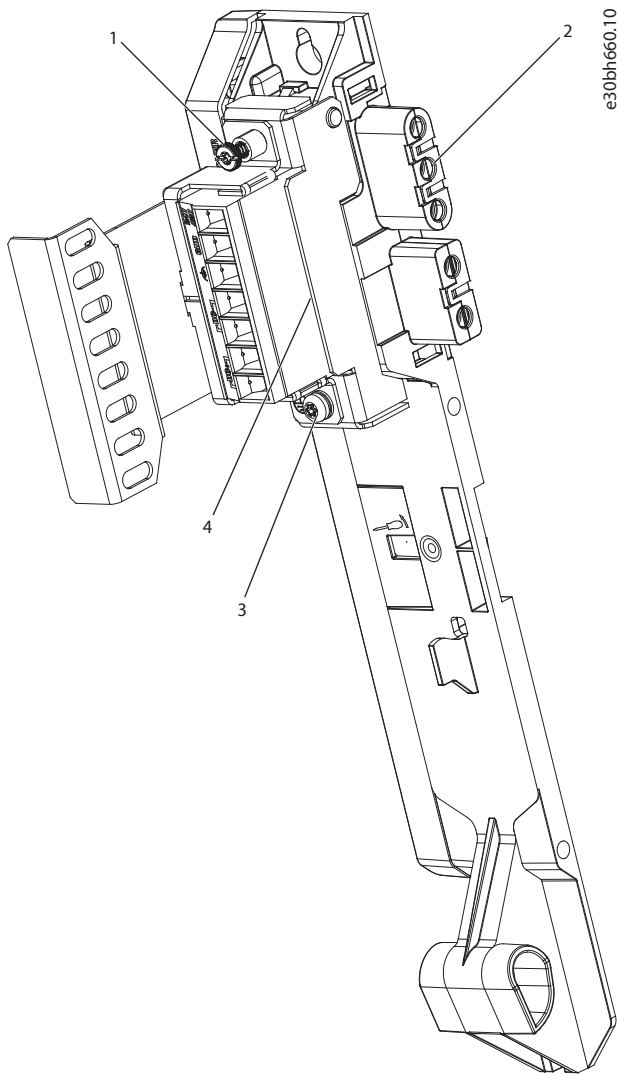

Figure 8: EXM 510

| | | | |
|---|---------------------|---|---------------------|
| 1 | EMC shielding plate | 2 | Backplate |
| 3 | PE screw | 4 | Expansion connector |

NOTICE

- The system modules are designed for use within a control cabinet. If the STO function is used, the cabinet must be rated at least IP54.
- The EXM 510 has a protection rating of IP20 according to IEC/EN 60529.
- The EXM 510 may be damaged if exposed to fluids.

An example type code for the EXM 510 is:

MSD510EXM510F1C062AD6E20XXXXXXXXXXXXXXXXXX

3.8 Cables

3.8.1 Hybrid Cable

All dimensions are in mm.

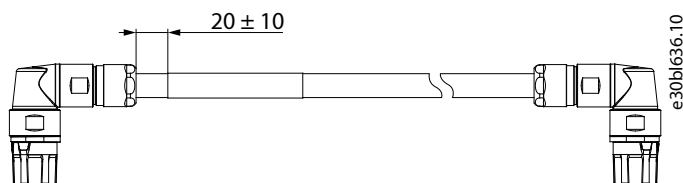

Figure 9: Hybrid Loop Cable

Pre-configured hybrid cables are used to connect the ISD 520/DSD 520 servo drives to the Decentral Access Module (DAM 510).

There are 2 types of hybrid cables that are available with both angled and straight M23 connectors:

- Feed-in cable for connecting the 1st ISD 520/DSD 520 servo drive of a group to the connection point on the Decentral Access Module (DAM 510).
- Loop cable for connecting the ISD 520/DSD 520 servo drives in daisy-chain format in an application.

Both these cables are provided by Danfoss and are available in various lengths. See the *VLT® Servo Drive System ISD 520, DSD 520, MSD 520 (VLT® FlexMotion™) Design Guide* for further information.

Both ends of the loop cable are fitted with M23 connectors.

The feed-in cable is fitted with an M23 connector at the output end for connection to the 1st ISD 520/DSD 520 servo drive. At the input end it is pigtailed and the connectors are mounted on the corresponding terminals on the Decentral Access Module (DAM 510).

Table 11: Hybrid Cables

| Cable type | Shielded/unshielded | Notes |
|---------------|---------------------|---|
| Feed-in cable | Shielded | Hybrid cable (overall shield with additional fieldbus and safety section shield). |
| Loop cable | | |

NOTICE

- Hybrid cables are available in 2 cross-sections: 2.5 mm² (15 A) and 4 mm² (25 A for CE and UL, 20 A for CSA).
- See the *VLT® Servo Drive System ISD 520, DSD 520, MSD 520 (VLT® FlexMotion™) Design Guide* for further information.

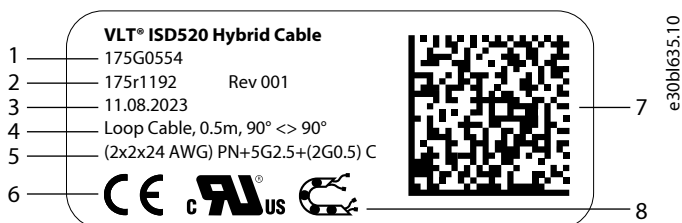

| | | | |
|---|--|---|--|
| 1 | Article number | 2 | Specification number |
| 3 | Production date | 4 | Cable configuration |
| 5 | Cable specification | 6 | Approvals |
| 7 | Data matrix code containing article number and production date | 8 | Cable characteristics, for example, drag chain |

Figure 10: Example of a Hybrid Cable Product Label

3.8.1.1 Minimum Bending Radius for Hybrid Cable

Table 12: Minimum Bending Radius

| | Static cable | Dynamic cable |
|------------------------|----------------------|---------------------|
| Cable diameter | 13.8 mm | 15.6 mm |
| Permanent installation | 25 mm bending radius | 5 x cable diameter |
| Flexible installation | Not allowed | 12 x cable diameter |

3.8.2 I/O and/or Encoder Cable

This cable connects the I/O and/or encoder to the ISD 520/DSD 520 servo drive (X4 connector). The cable is not included with the servo drives.

I/O and/or encoder cables with M12 connectors can be used for the ISD 520/DSD 520 system if they comply with the form factor defined in IEC 61076-2-101.

3.8.3 Fieldbus Extension Cable

Cable length: 2 m

Maximum length to next port: 100 m

If this cable is not used, fit the M23 metal blind cap to the X2 female connector on the last ISD 520/DSD 520 servo drive in the application.

3.8.4 LCP Cable

The LCP cable connects the LCP to the ISD 520/DSD 520 servo drive and the system modules via an M8 connector.

The LCP cable can be purchased from Danfoss (see the *VLT® Servo Drive System ISD 520, DSD 520, MSD 520 (VLT® FlexMotion™) Design Guide* for further information and code numbers).

3.9 Cable Layout and Routing

3.9.1 Standard Cabling Concept for 2 Lines

This cabling concept is for 2 lines, without redundancy for ISD 520/DSD 520 servo drives in an application. For each additional line of servo drives, 1 additional DAM 510 is required. For cabling concepts with only 1 line, only 1 DAM 510 is required.

NOTICE

- For cabling with redundancy, see the *VLT® Servo Drive System ISD 520, DSD 520, MSD 520 (VLT® FlexMotion™) Design Guide*.

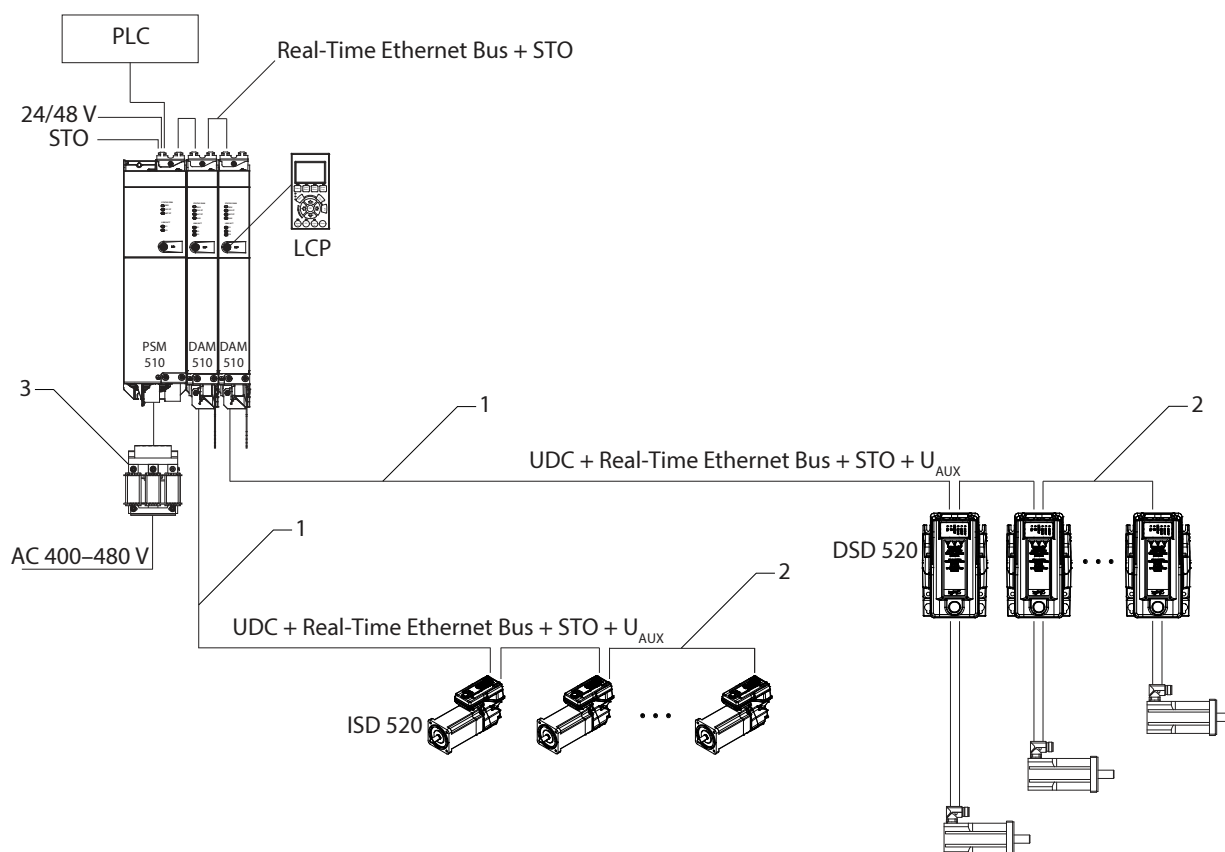

Figure 11: Standard Cabling Concept for 2 Lines

| | | | |
|---|-------------------|---|----------------|
| 1 | M23 feed-in cable | 2 | M23 loop cable |
| 3 | AC line choke | | |

3.10 Local Control Panel

3.10.1 Overview of the Local Control Panel

The LCP is the graphical user interface that can be connected to the PSM 510, DAM 510, and ACM 510 for diagnostic and operating purposes using an optional cable (M8 to LCP D-SUB cable).

The LCP is available as an option and can also be connected to the servo drives using the same optional cable.

The LCP display provides the operator with a quick view of the state of the ISD 520/DSD 520 servo drive or system module, depending on which device it is connected to. The display shows parameters and alarms/errors and can be used for commissioning and troubleshooting. It can also be used to perform simple functions, for example activating and deactivating the output lines on the DAM 510.

The LCP can be mounted on the front of the control cabinet and then connected to the system modules via SUB-D cables. The maximum cable length is 3 m.

3.10.2 Layout of the Local Control Panel

The local control panel is divided into 4 functional groups:

- A: Display area
- B: Display menu keys
- C: Navigation keys and indicator lights (LEDs)

- D: Operation keys and reset

To adjust the display contrast, press [Status] and the [▲]/[▼] keys.

3.10.2.1 A: Display area

The values in the display area differ depending on whether the LCP is connected to a Danfoss servo drive or system module.

The display area is activated when the servo drive or module it is connected to receives power from the mains supply, a DC bus terminal, or U_{AUX} .

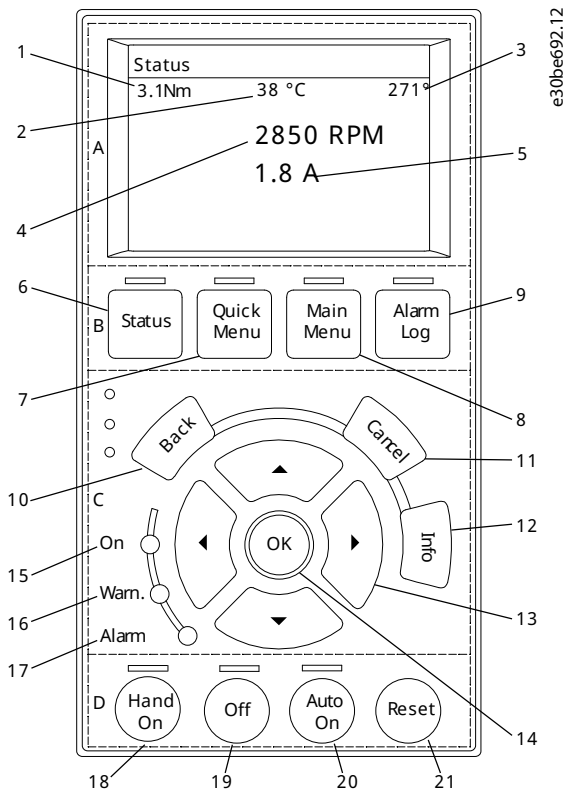

Figure 12: Display Area when Connected to an ISD 520/DSD 520 Servo Drive

Table 13: Legend Table for Display Area when Connected to an ISD 520/DSD 520 Servo Drive

| | Description |
|---|--------------------------|
| 1 | Actual torque |
| 2 | Temperature drive module |
| 3 | Position |
| 4 | Speed |
| 5 | Current |

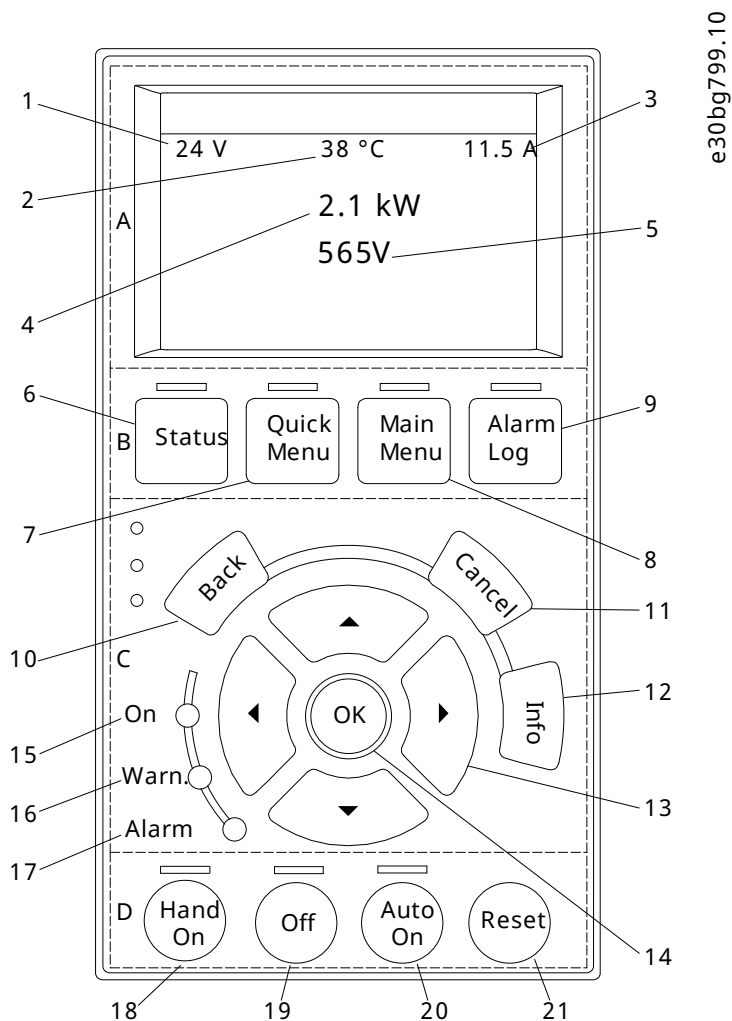
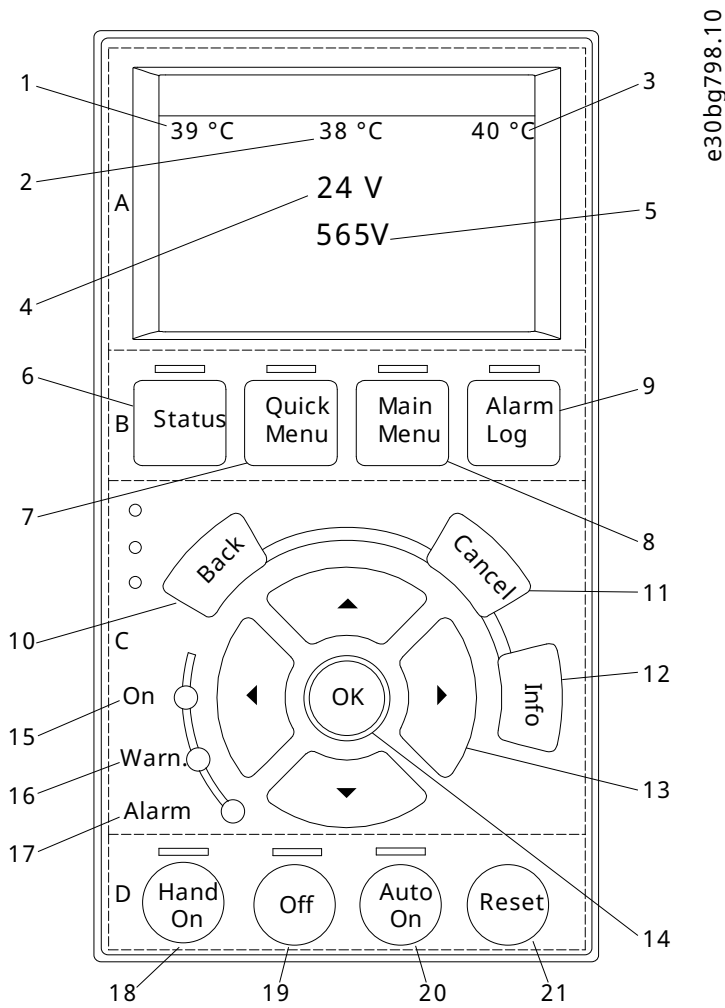

Figure 13: Display Area when Connected to PSM 510 and DAM 510

Table 14: Legend Table for Display Area when Connected to PSM 510 and DAM 510

| | Description |
|---|-------------------------|
| 1 | U_{AUX} mains voltage |
| 2 | Temperature power board |
| 3 | Actual UDC (current) |
| 4 | Power consumption |
| 5 | Actual UDC (voltage) |



e30bg798.10

Figure 14: Display Area when Connected to ACM 510

Table 15: Legend Table for Display Area when Connected to ACM 510

| | Description |
|---|------------------------------|
| 1 | Temperature power board |
| 2 | Temperature capacitor bank 1 |
| 3 | Temperature capacitor bank 2 |
| 4 | U _{AUX} voltage |
| 5 | Actual UDC (voltage) |

3.10.2.2 B: Display menu keys

Menu keys are used for menu access for parameter setup, toggling through status display modes during normal operation, and viewing fault log data.

Table 16: Display Menu Keys

| | Key | Function |
|---|------------|--------------------------------|
| 6 | Status | Shows operational information. |
| 7 | Quick Menu | Allows access to parameters. |

Table 16: Display Menu Keys - (continued)

| | Key | Function |
|---|-----------|------------------------------|
| 8 | Main Menu | Allows access to parameters. |
| 9 | Alarm Log | Shows the last 10 alarms. |

3.10.2.3 C: Navigation keys and indicator lights (LEDs)

Navigation keys are used for moving the display cursor and provide operation control in local operation. There are also 3 status indicator lights (LEDs) in this area.

Table 17: Navigation Keys

| | Key | Function |
|----|-----------------|--|
| 10 | Back | Reverts to the previous step or list in the menu structure. |
| 11 | Cancel | Cancels the last change or command as long as the display mode is not changed. |
| 12 | Info | Press for a definition of the function being shown. |
| 13 | Navigation keys | Use the 4 navigation keys to move between items in the menu. |
| 14 | OK | Use to access parameter groups or to enable a selection. |

Table 18: Indicator Lights (LEDs)

| | LED | Color | Function |
|----|-------|--------|--|
| 15 | On | Green | The <i>On</i> LED activates when the servo drive or module it is connected to receives power from U_{AUX} . |
| 16 | Warn | Yellow | When warning conditions are met, the yellow <i>Warn</i> LED is activated and text appears in the display area identifying the problem. |
| 17 | Alarm | Red | A fault condition causes the red <i>Alarm</i> LED to flash and an alarm text is shown. |

3.10.2.4 D: Operation keys and reset

The operation keys are at the bottom of the LCP.

Table 19: Operation Keys and Reset

| | Key | Function |
|----|---------|--|
| 18 | Hand On | Enables the connected ISD 520/DSD 520 servo drive or PSM 510/DAM 510/ACM 510 to be controlled via the LCP. |
| 19 | Off | Puts the ISD 520/DSD 520 servo drive into state <i>Switch on Disabled</i> and the PSM 510/DAM 510/ACM 510 into state <i>Standby</i> . This only works in <i>Hand On</i> mode. <i>Off</i> mode enables transition from <i>Hand On</i> mode to <i>Auto On</i> mode. |
| 20 | Auto On | Puts the system in remote operational mode. In <i>Auto On</i> mode, the device is controlled by fieldbus (PLC). Switching between <i>Auto On</i> and <i>Hand On</i> modes is only possible when the drive is in state <i>Switch on Disabled</i> and/or the PSM 510/DAM 510/ACM 510 is in state <i>Standby</i> . |
| 21 | Reset | Resets the ISD 520/DSD 520 servo drive or PSM 510/DAM 510/ACM 510 after a fault has been cleared. The reset is only possible when in <i>Hand On</i> mode. |

3.11 Software

The software for the servo system comprises:

- The firmware of the ISD 520/DSD 520 that is already installed on the device.
- The firmware of the system modules that is already installed on the modules.
- A package of PLC libraries for Automation Studio™ for operating the ISD 520/DSD 520 servo drives and the system modules (see [6.10.2 Creating an Automation Studio™ Project](#) for further information).
- A PLC library for TwinCAT® 3 for operating the ISD 520/DSD 520 servo drives and the system modules (see [6.11.2 Creating a TwinCAT® Project](#) for further information).
- A PLC library for TIA Portal for operating the ISD 520/DSD 520 servo drives and the system modules.
- VLT® Servo Toolbox: A Danfoss PC-based software tool for commissioning and debugging the devices.

3.12 Fieldbus

3.12.1 Overview

The servo system has an open system architecture realized by fast Ethernet (100BASE-T) based communication. The system supports EtherCAT®, Ethernet POWERLINK®, and PROFINET® fieldbuses.

In productive environments, communication to the devices always takes place via a PLC that acts as a master. The ISD 520/DSD 520 servo drives and the system modules can be controlled by these communication methods:

- Using the VLT® Servo Motion libraries (available for TwinCAT®, Automation Studio™ and Tia Portal).
- Using the NC axis functionality of TwinCAT® (ISD 520/DSD 520 only).

- Using the CANopen® CiA DS 402 standard by reading and writing to objects.
- Using application class 1 (AC1) and PROFINET® only.

The ISD 520/DSD 520 servo drives and the system modules can be operated with the following cycle times:

- EtherCAT® and Ethernet POWERLINK® fieldbuses:
 - 400 µs and multiples of it (for example, 800 µs and 1200 µs).
 - 500 µs and multiples of it (for example, 1 ms).
- PROFINET® fieldbus
 - 1 ms, 2 ms, and 4 ms.

When the cycle time is a multiple of 400 µs and 500 µs, the time base of 500 µs is used.

The ISD 520/DSD 520 servo drives and the system modules are certified for fieldbuses according to the corresponding rules and regulations. The servo drives conform to the CANopen® CiA DS 402 Drive Profile.

3.12.2 EtherCAT®

The ISD 520/DSD 520 servo drives and the system modules support the following EtherCAT® protocols:

- CANopen over EtherCAT® (CoE)
- File Access over EtherCAT® (FoE)
- Ethernet over EtherCAT® (EoE)

The ISD 520/DSD 520 servo drives and the system modules support distributed clocks. To compensate for the failure of a communication cable section in the system, cable redundancy is available for all fieldbuses. See the *VLT® Servo Drive System ISD 520, DSD 520, MSD 520 (VLT® FlexMotion™) Design Guide* for further information.

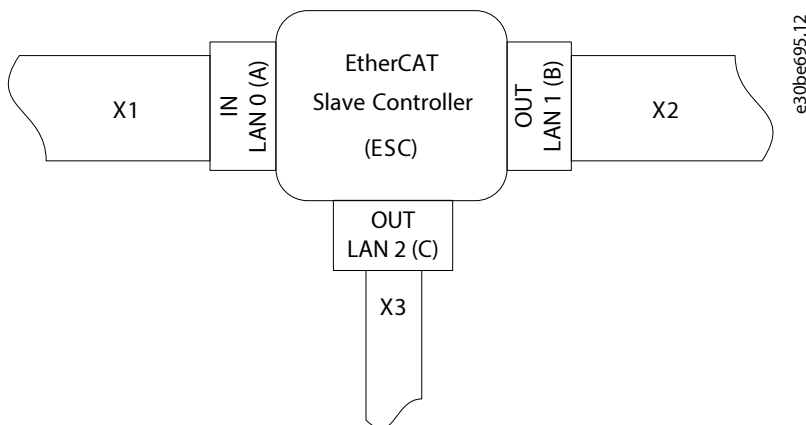

Figure 15: EtherCAT® Port Assignment for the ISD 520/DSD 520 Servo Drive

| | | | |
|----|--|----|--|
| X1 | M23 hybrid cable connector to Decentral Access Module (DAM 510) or previous servo drive (EtherCAT IN). | X2 | M23 hybrid cable connector to the next servo drive (EtherCAT OUT 1). |
| X3 | M8 Ethernet cable connector to other EtherCAT® slaves, for example, EtherCAT® encoder (EtherCAT OUT 2). The connector is only available on the advanced servo drives. | | |

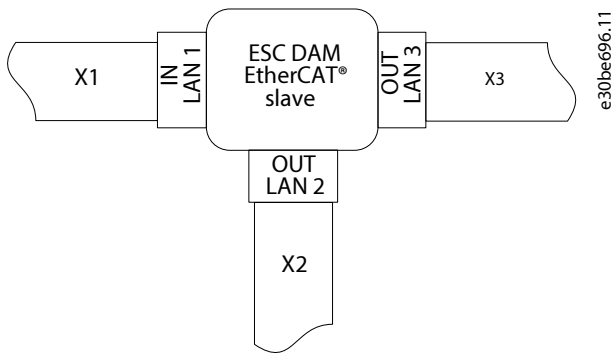

Figure 16: EtherCAT® Port Assignment for the Decentral Access Module (DAM 510)

| | | | |
|-----------|---|-----------|--|
| X1 | RJ45 cable connector to the previous slave. | X2 | RJ45 to M23 hybrid feed-in cable to the 1st ISD 520/DSD 520 servo drive. |
| X3 | RJ45 cable connector to the PLC (cable redundancy) or next slave. | | |

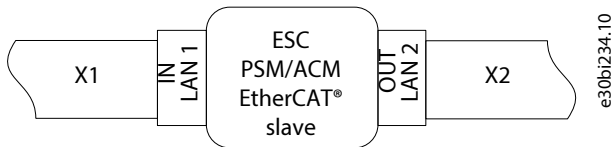

Figure 17: EtherCAT® Port Assignment for the Power Supply Module (PSM 510), Auxiliary Capacitors Module (ACM 510), and ISD 520/DSD 520 Servo Drives

| | | | |
|-----------|--|-----------|--|
| X1 | RJ45 cable connector to the PLC or previous slave (EtherCAT IN). | X2 | RJ45 cable connector to the PLC (cable redundancy) or next slave (EtherCAT OUT). |
|-----------|--|-----------|--|

3.12.3 Ethernet POWERLINK®

The ISD 520/DSD 520 servo drives and the system modules are certified according to DS 301 V1.1.0 and support the following features:

- Work as controlled node.
- Can be operated as multiplexed stations.
- Support of cross-communication.
- Ring redundancy supported for media redundancy.
- Specific ports are not assigned for Ethernet POWERLINK®.

3.12.4 PROFINET®

The ISD 520/DSD 520 servo drive and system modules support PROFINET® conformance class C as per IEC 61158-5-10:2014, IEC 61158-6-10:2014, IEC 61784-2:2014, and IEC 61784-5-3:2013. All the system components (servo drives and system modules) act as I/O devices in a PROFINET® network.

The following features are supported:

- I/O-Device: Device that is being controlled by I/O-Controller.
- Dynamic module configuration.
- Net load class II.
- Ring redundancy (MRP) as client.

PROFINET® fieldbus devices are always connected as network components via switches that are integrated in the fieldbus device.

There are 2 ports on the ISD 520/DSD 520 servo drives, the PSM 510, and the ACM 510. There are 3 ports on the DAM 510. Only 2 can be used for Isochronous Real-Time (IRT) protocol, whereas all 3 can be used for Real-Time (RT) protocol. If the DAM 510 with IRT is ordered, an RJ45 cover is mounted to the X3 OUT port. Remove this cover to enable use of the X3 OUT port required for switching to RT protocol.

The wiring concept for the use of multiple DAM 510 modules in a single application is shown in [Figure 18](#).

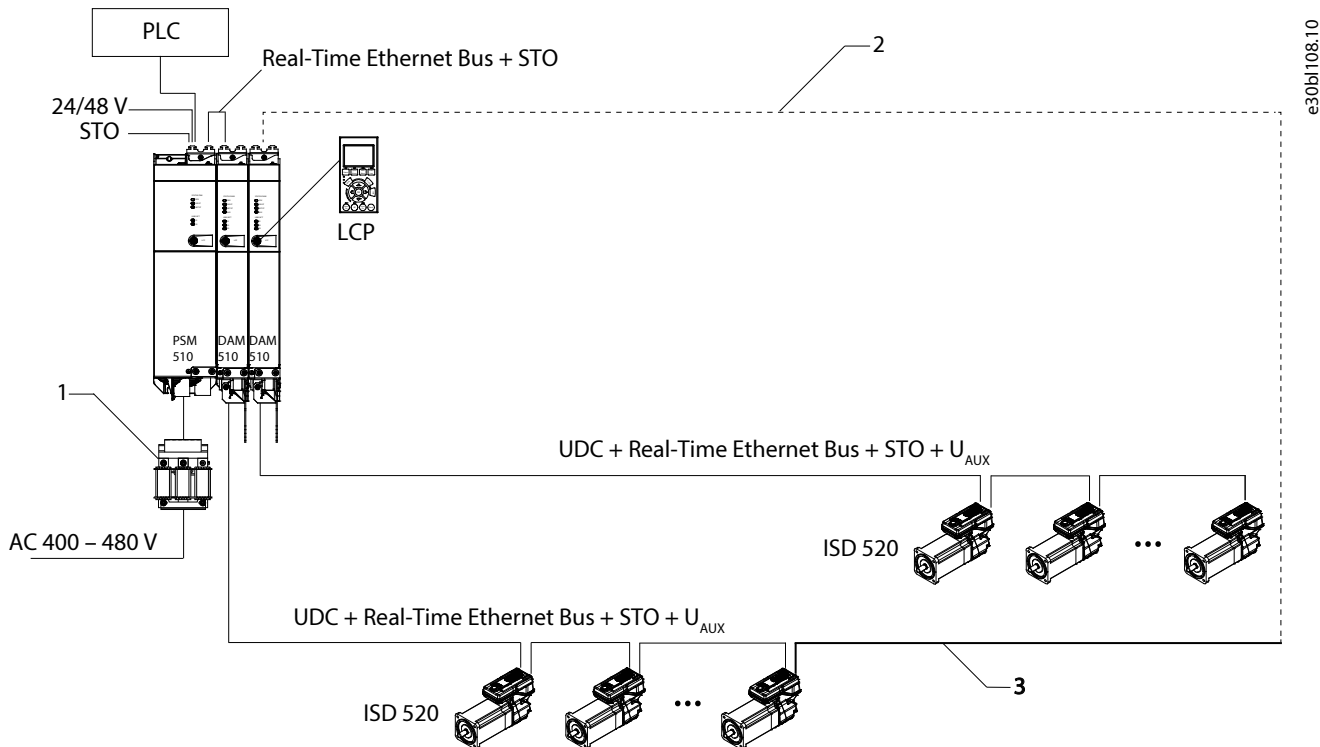

Figure 18: Wiring Concept for Multiple DAM 510 Modules

| | | | |
|---|--------------------------|---|----------------|
| 1 | AC line choke | 2 | Customer cable |
| 3 | Fieldbus extension cable | | |

4 Mechanical Installation

4.1 Items Supplied

The items supplied for the ISD 520/DSD 520 servo systems are:

- ISD 520/DSD 520 servo drives
- Power Supply Module (PSM 510) including connectors
- Decentral Access Module (DAM 510) including connectors
- Auxiliary Capacitors Module (ACM 510) including connectors, optional
- Expansion Module (EXM 510), optional
- Local control panel (LCP), optional
- This operating guide
- Feed-in (hybrid) cable
- Loop (hybrid) cable
- LCP cable, optional
- Fieldbus extension cable, optional
- Blind caps for connectors M8, M12, and M23

The packaging unit depends on the number of servo drives delivered. Save the packaging for use in the event of product return.

4.2 Transport

- The servo drives are delivered with plastic M23 protection caps and a shaft protection cap fitted. These plastic protection caps prevent damage during transport and handling.
- Always use means of transport and lifting gear with sufficient load capacity to transport the servo system components.
- Avoid vibration during transport.
- Avoid heavy impacts and blows.

4.3 Inspection on Receipt

Procedure

1. After receiving the delivery, immediately check whether the items supplied match the shipping documents. Danfoss does not honor claims for faults registered later.
2. Register a complaint immediately with the carrier if there is visible transport damage.
3. Register a complaint immediately with the responsible representative if there are visible defects or the delivery is incomplete.

4.4 Safety Measures during Installation

Always observe the safety instructions in this guide during installation.

- Ensure that installation is performed by qualified personnel.
- Carry out installation with due care and attention.
- Comply with all safety regulations and protective measures and observe the environmental conditions.
- Ensure that this guide is read and understood.

4.5 Installation Environment

4.5.1 Overview

The installation must provide the following environmental conditions to allow the ISD 520/DSD 520 system to be operated safely and efficiently.

Contact Danfoss if it is not possible to comply with these environmental conditions.

4.5.2 ISD 520/DSD 520 Servo Drive

- The allowable operating ambient temperature range, humidity, and vibration levels must not be exceeded. (See [11.11.1 ISD 520/DSD 520 Servo Drive](#).)
- Ensure that ventilation to the ISD 520/DSD 520 servo drives is not restricted.

WARNING

RISK OF COMBUSTION OF THE MOUNTING STRUCTURE

The surface of the drive can exceed 90 °C, which may result in the combustion of the mounting surface, product damage, or injury.

- Ensure that the mounting structure is suitable for the application, for example, adequately rigid and able to handle temperatures over 90 °C.

4.5.3 System Modules

The environmental conditions for the PSM 510, DAM 510, and ACM 510 are:

- The allowable operating ambient temperature range, humidity, and vibration levels must not be exceeded (see [11.11.2 System Modules](#)).
- The minimum space required above and below the system modules is detailed in [4.7.3 Space Requirements for System Modules](#).

4.6 Preparation for Installation

4.6.1 Preparation for Installation of ISD 520/DSD 520 Servo Drive

Make the following preparations to ensure that the servo system can be installed reliably and effectively.

Always fit couplings and other transfer components in accordance with local regulations.

Procedure

1. Provide a suitable mounting arrangement for the application. This depends on the type, weight, and power size of the ISD 520/DSD 520 servo drives.
2. For the ISD 520 servo drives, seat the motor flange flush against the mounting surface before fixing the servo drive. Misalignment shortens the life of the bearings and the coupling components and reduces heat transfer from the servo drive. Ensure that the seal is not bumped when inserting the drive into the machine as that could damage the seal resulting in impaired sealing function and reduced service lifetime.
3. For the DSD 520 servo drives, seat the bottom side of the DSD 520 to the mounting surface before fixing the servo drive. Misalignment reduces heat transfer from the servo drive.
4. Provide contact protection according to local regulations if hot surfaces can be expected during operation.
5. Ground the servo drives (see [5.4.1 Grounding the ISD 520 Servo Drive](#) and [5.4.2 Grounding the DSD 520 Servo Drive](#)).

NOTICE

- The motor flange and shaft are vulnerable during storage and assembly. Blows or the use of force can result in damage to the bearings, shaft, and motor feedback.
- Only use suitable tools to mount or pull off pulleys or couplings.
- Rotors are dynamically balanced with half key, in accordance with standard DIN ISO 8821.

4.6.2 Preparation for Installation of System Modules

Make the following preparations to ensure that the servo system can be installed reliably and effectively.

Always fit the system modules in accordance with local regulations.

Procedure

1. Provide a suitable mounting arrangement for the application. This depends on the type and weight of the modules.
2. To avoid misalignment, ensure that the backplates are perfectly level.
3. To ensure sufficient cooling, pay attention to the specified minimum space requirements (see [4.7.3 Space Requirements for System Modules](#)).
4. Ground the modules.

4.6.3 Drilling Templates

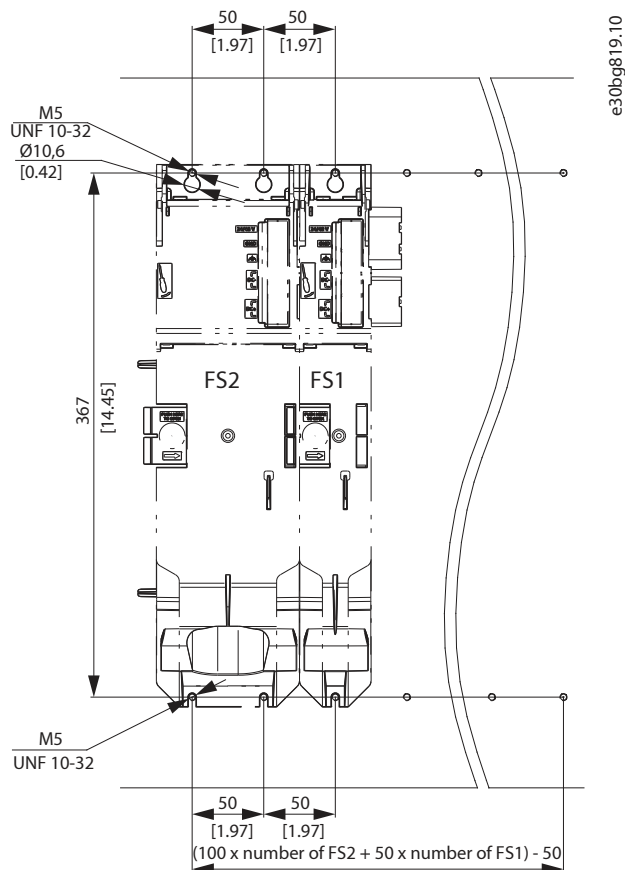

Figure 19: Drilling templates for 50 mm (FS1) and 100 mm (FS2) System Modules

4.7 Installation Procedure

4.7.1 Space Requirements for ISD 520 Servo Drive

In addition to its own dimensions, the servo drive needs space for the hybrid cable.

[Figure 20](#) shows the space required for the straight connector.

[Figure 21](#) shows the space required for the angled connector.

The illustrations show the minimum distance from the servo drive to the next object, and the minimum allowable bending radius R_{min} for permanently installed cable. For cable installation, allow the height of the connector plus an additional 30 mm for the cable.

The minimum distance is measured from the electronic housing as this is the same for all motor variants.

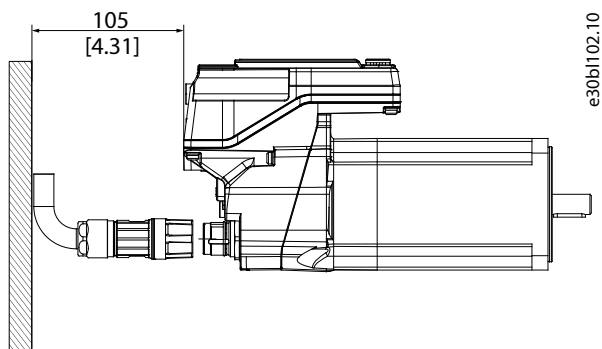

Figure 20: Minimum Distance for M23 Straight Connector on ISD 520

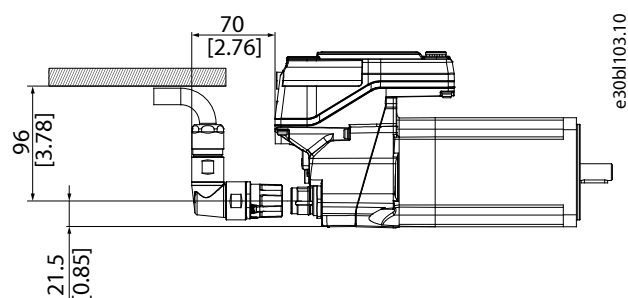

Figure 21: Minimum Distance for M23 Angled Connector on ISD 520

4.7.2 Space Requirements for DSD 520 Servo Drive

In addition to its own dimensions, the servo drive needs space for the hybrid cable.

[Figure 22](#) shows the straight connector installed on a DSD 520 servo drive.

[Figure 23](#) shows the angled connector installed on a DSD 520 servo drive.

The illustrations show the minimum distance from the servo drive to the next object, and the minimum allowable bending radius R_{min} for permanently installed cable. For cable installation, allow the height of the connector plus an additional 30 mm for the cable.

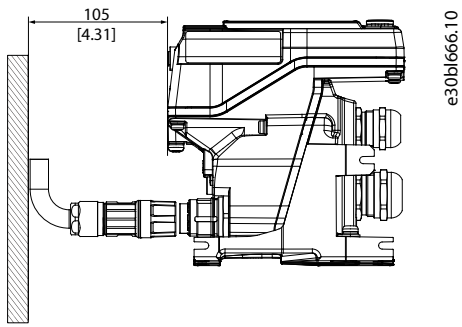

Figure 22: Minimum Distance for M23 Straight Connector on DSD 520

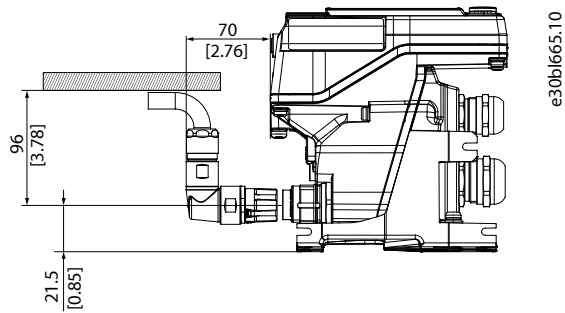

Figure 23: Minimum Distance for M23 Angled Connector on DSD 520

4.7.3 Space Requirements for System Modules

The modules can be mounted next to each other but require a minimum space at the top and bottom for cooling.

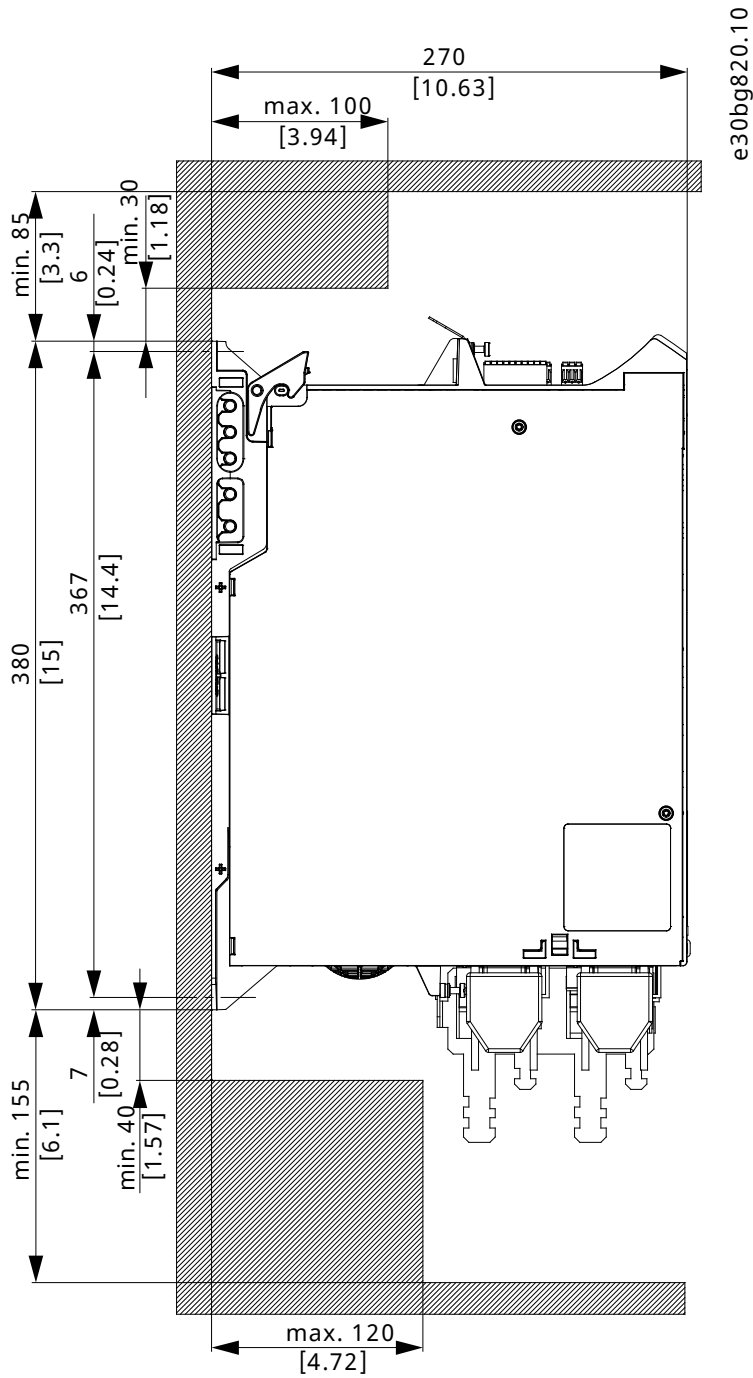

Figure 24: Minimum Space Required at the Top and Bottom

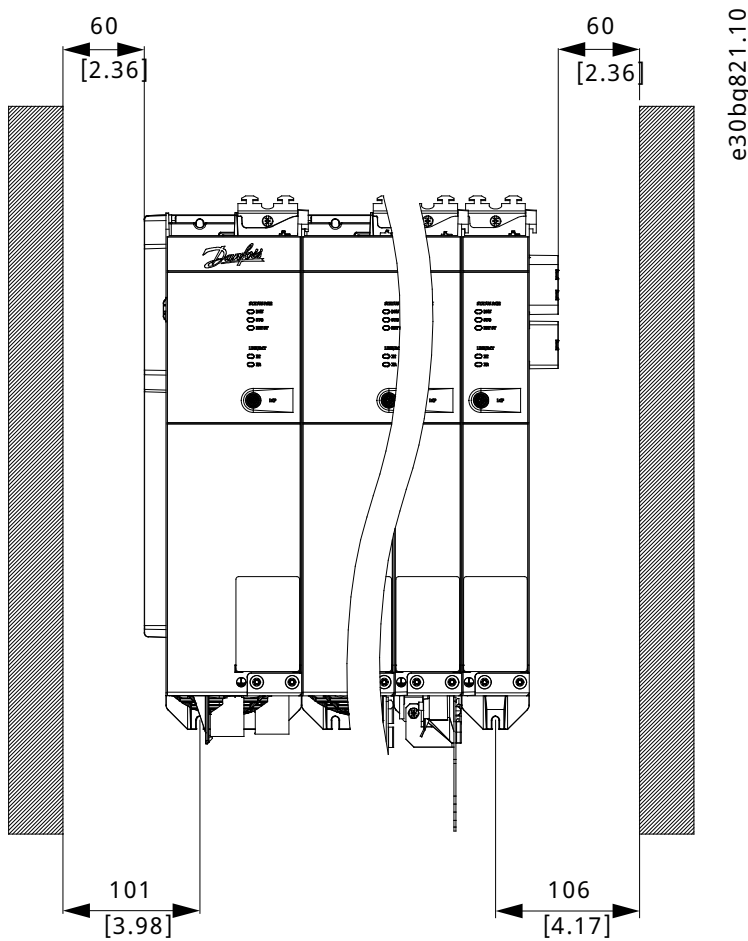

Figure 25: Minimum Space Required at the Sides

4.7.4 Installation Aids and Tools Required

For installation of the ISD 520 servo drives, the tools corresponding to the fixings screws (not included) are required (see [4.7.5.4 Fixing Screws and Tightening Torques](#)).

4.7.5 Fitting Instructions for ISD 520 Servo Drive

4.7.5.1 Overview

The ISD 520 servo drives are delivered with plastic M23 transport protection caps. To ensure IP protection, replace the plastic protection caps with the M23 metal protection caps (which must be ordered separately). Always mount a metal protection cap if a connector is not used.

The ISD 520 servo drives are delivered with M8 and M12 protection caps. These protection caps prevent contamination of the servo drive and are necessary to achieve the relevant IP protection rating. Always mount these caps if the connector is not used.

NOTICE

- Ensure that the machine surface that comes in contact with the ISD 520 servo drive flange is unpainted to guarantee good thermal behavior of the servo drive. The surface contact must also provide sufficient grounding protection if the ISD 520 servo drive is grounded using the motor flange.

4.7.5.2 Clamping the ISD 520 Servo Drive

Observe the following fitting instructions to ensure the reliable and effective fitting of the ISD 520 servo drive.

Procedure

1. Check the mounting surface and ensure that it has sufficient heat dispersion capacity.
2. Remove the protective end cap from the shaft.
3. Fix the servo drive with 4 screws using the 4 mounting holes provided for this purpose in the machine unit as shown.
 - Always use the designated mounting holes in the mounting flange to fix the servo drive.
 - Do not modify the mounting holes.
 - Always use all 4 mounting holes. The motor may run unevenly if fewer mounting holes are used.

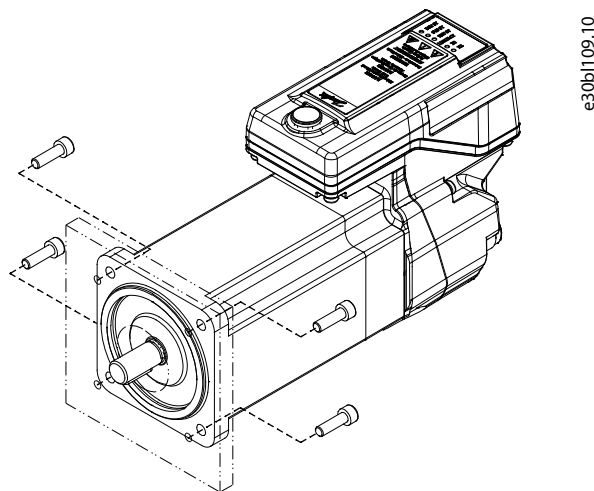

Figure 26: Mounting of ISD 520 Servo Drives

4.7.5.3 Coupling the ISD 520 Servo Drive

Observe the following safety warnings before coupling the ISD 520 servo drive.

| NOTICE |
|---|
| <ul style="list-style-type: none"> Do not machine the shaft. Do not use the ISD 520 servo drive if the shaft does not match the coupling arrangement. Ensure correct alignment of the couplings as incorrect placement will result in unacceptable vibration levels. |

| NOTICE |
|--|
| <p>DO NOT USE EXCESSIVE FORCE DURING THE FITTING PROCEDURE:</p> <ul style="list-style-type: none"> Do not exceed the specified vibration limits. Do not exceed the specified allowed forces. Do not use force to press or hammer the motor shaft into a machine. |

Procedure

1. Align the clamping set to the axis of the ISD 520 servo drive.
2. Insert the shaft in the clamping set.
3. Screw the clamping set together.

4.7.5.4 Fixing Screws and Tightening Torques

Always tighten the screws uniformly and crosswise.

Table 20: Fixing Screws

| Flange size [mm] | Flange thickness [mm] | Hole size [mm] | Recommended screw type ⁽¹⁾ | Recommended tightening torque [Nm] |
|------------------|-----------------------|----------------|--|------------------------------------|
| 70 | 9.0 | 5.8 | M5, Hexagon socket head cap screw | 3.5 |
| 87 | 42.5 | – | M6, Hexagon socket head cap screw ⁽²⁾ | 7–8.5 |
| 91 | 11.0 | 6.5 | M6, Hexagon socket head cap screw | 7–8.5 |
| 100 | 10.0 | 9.0 | M8, Hexagon socket head cap screw | 17–21 |
| 116 | 12.0 | 9.0 | M8, Hexagon socket head cap screw | 17–21 |
| 142 | 12.0 | 12.5 | M12, Hexagon socket head cap screw | 57–70 |

1) Use a screw with a strength class of minimum 8.8.

2) The ISD 520 can be fixed from both sides of the flange. When using the thread on the flange, an M8 screw is required, otherwise an M6 flange screw must be used to fix the ISD 520 to the mounting plate (see [Figure 27](#)).

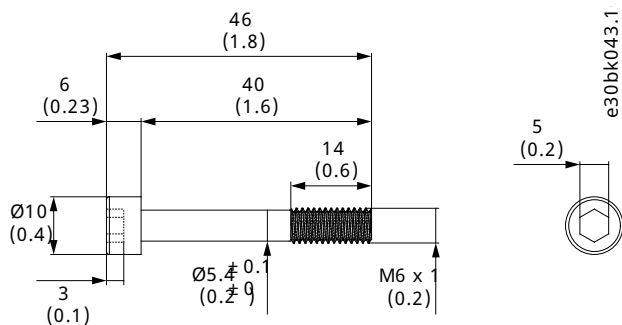

Figure 27: M6 Flange Screw Dimensions

NOTICE

- The fixing screws are not supplied and must be selected according to the machine fixings.

4.7.6 Fitting Instruction for DSD 520 Servo Drive

4.7.6.1 Overview

The DSD 520 servo drives are delivered with plastic M23 transport protection caps. To ensure IP protection, replace the plastic protection caps with the M23 metal protection caps (which must be ordered separately). Always mount a metal protection cap if a connector is not used.

The DSD 520 servo drive is delivered with M8 and M12 protection caps. These protection caps prevent contamination of the servo drive and are necessary to achieve the relevant IP protection rating. Always mount these caps if the connector is not used.

4.7.6.2 Clamping the DSD 520 Servo Drive

Observe the following fitting instructions to ensure the reliable and effective fitting of the DSD 520 servo drive.

Procedure

1. Check the mounting surface and ensure that it has sufficient heat dispersion capacity. An unpainted surface is mandatory.

2. Drill the holes for mounting the DSD 520 (see [11.3.2 Dimensions of DSD 520 Servo Drive](#)).
3. Mount the DSD 520 to the mounting plate using M4 screws with a minimum strength class of 8.8. The 2 possible mounting positions are shown in [Figure 28](#).
 - The tightening torque is 3 Nm
 - Always use all 4 mounting holes for top mounting.
 - Always use all 3 mounting holes for side mounting.

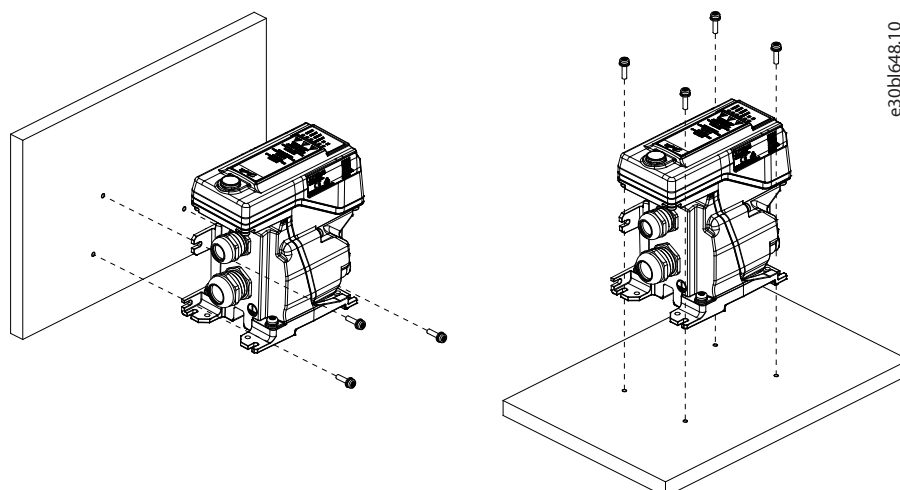
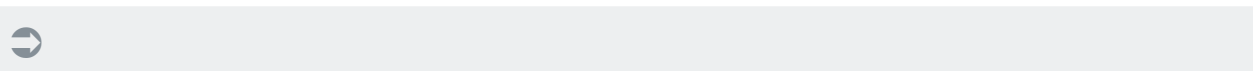

Figure 28: Mounting of DSD 520 Servo Drive

4.7.7 Fitting Instructions for System Modules

Procedure

1. Drill the holes for mounting the backplate as per the drilling template (see [4.6.3 Drilling Templates](#)).
2. Connect the backplates and the end cap via the click and lock method.



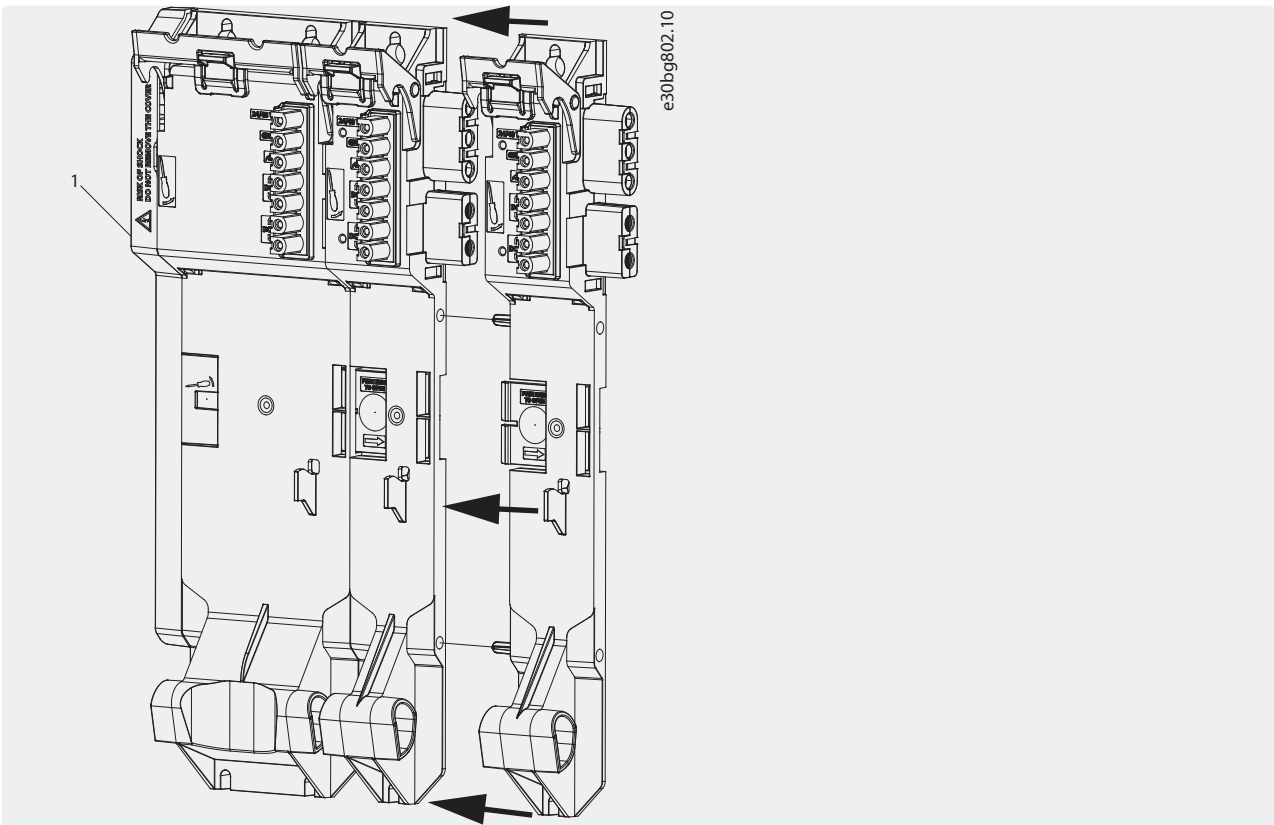

Figure 29: Connecting the Backplates

1 Backplate End Cap

3. Mount the backplates to the mounting plate in the control cabinet using M5 screws with a minimum head diameter or washer diameter of 9.5 mm. The tightening torque is 3 Nm.



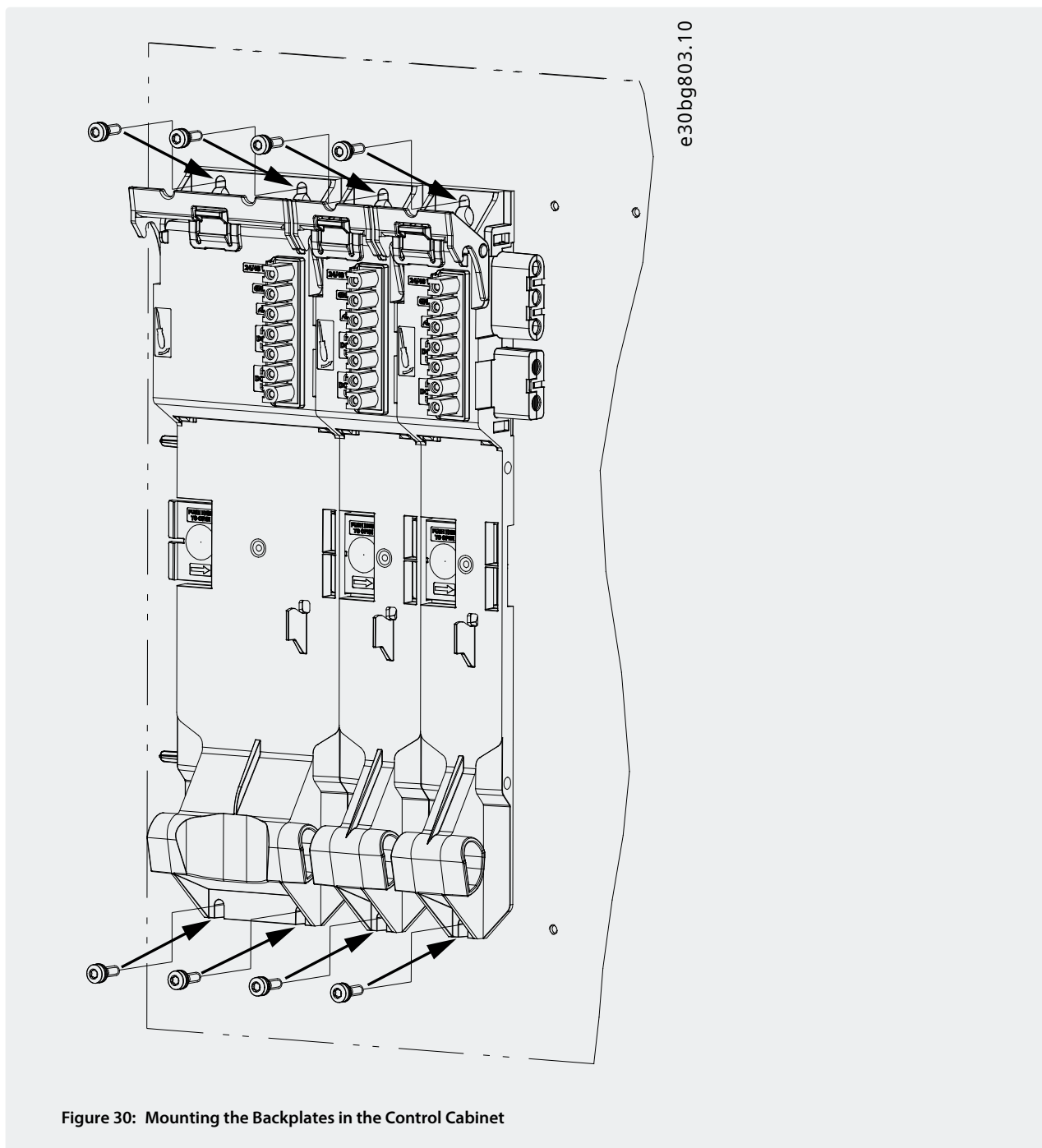

Figure 30: Mounting the Backplates in the Control Cabinet

4. Slide the module onto the carrier at the bottom of the backplate.
5. Press the 1st module onto the backlink connector at the top of the backplate.



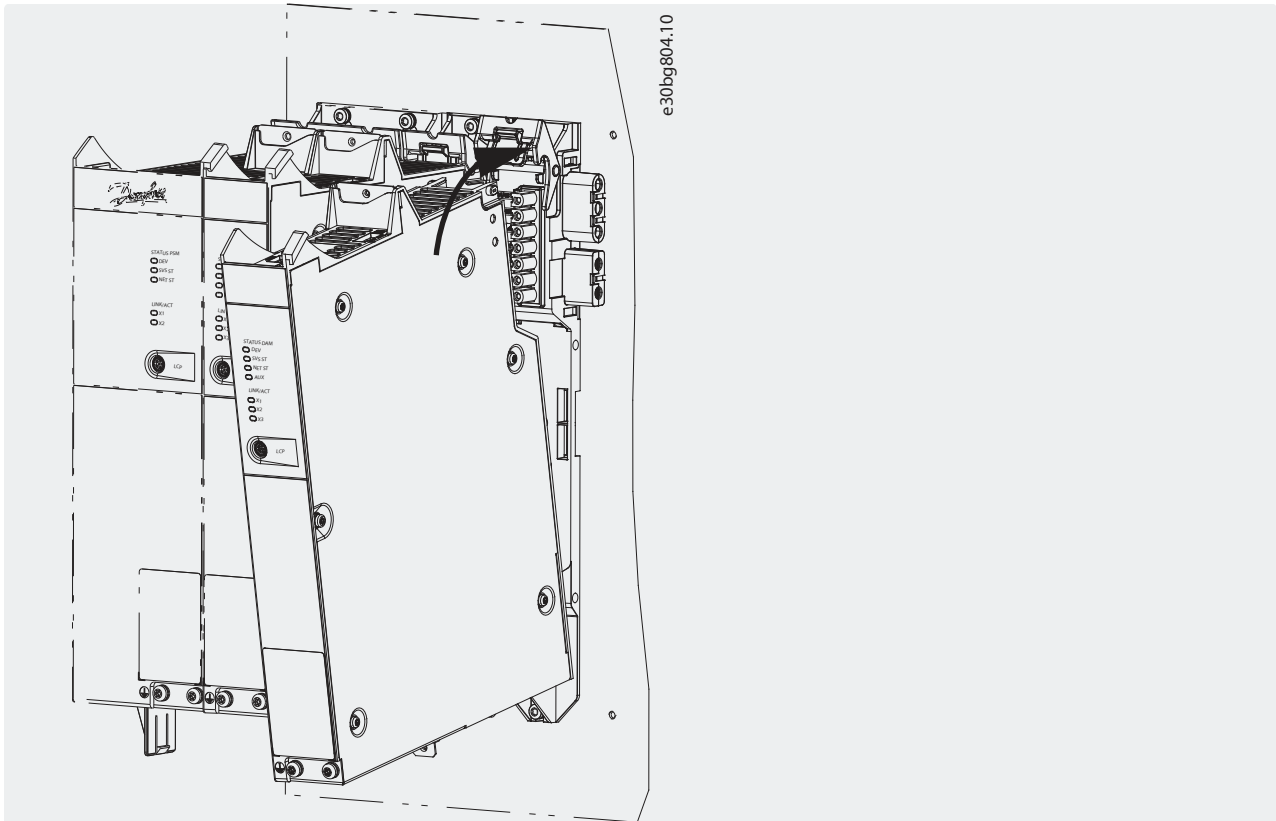

Figure 31: Pressing the Module onto the Backlink Connector

6. To secure the module, pull down the holding clamp ([1] in [Figure 32](#)) at the top of the backplate.

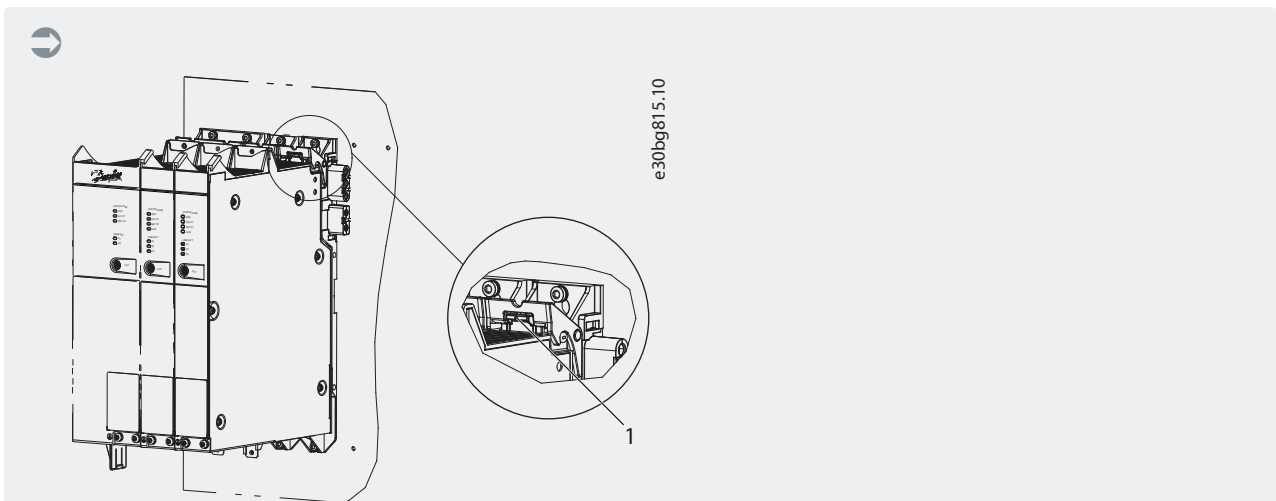
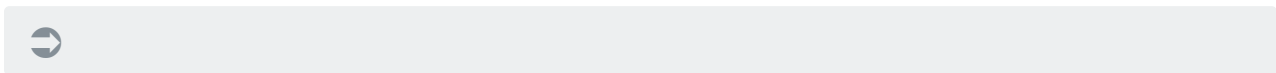

Figure 32: Pulling Down the Holding Clamp at the Top of the Backplate

- | | |
|---|---------------|
| 1 | Holding clamp |
|---|---------------|

7. Repeat steps 4, 5, and 6 for the remaining modules, ensuring that the lip at the left side of the 2nd module is inside the guiding groove at the right side of the 1st module ([1] in [Figure 33](#)).



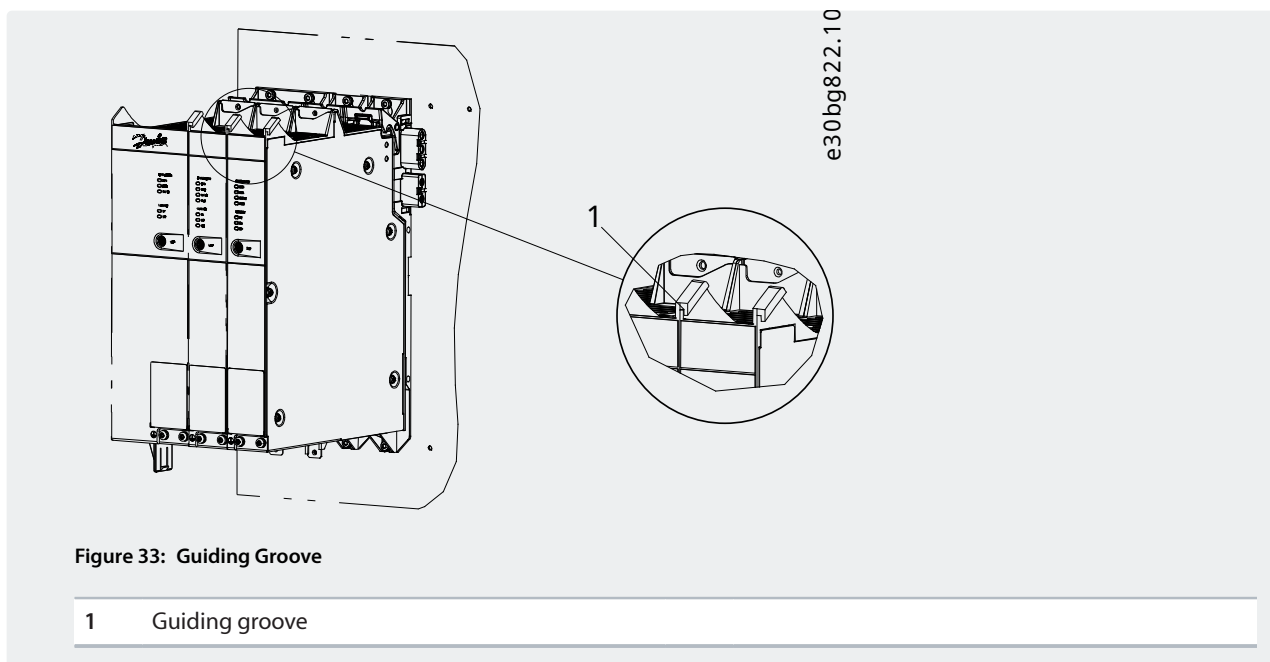

Figure 33: Guiding Groove

5 Electrical Installation

5.1 Warnings for Electrical Installation

During electrical installation, observe the relevant local and national regulations in addition to the information in this guide.

WARNING



HIGH VOLTAGE

The servo system contains components that operate at high voltage when connected to the electrical supply network. Not all components have indicators that indicate the presence of mains supply. Incorrect installation, commissioning, or maintenance may lead to death or serious injury.

- Installation, commissioning, and maintenance may only be performed by qualified personnel.

WARNING



HIGH VOLTAGE

Potentially lethal voltage is present on the connectors that may lead to death or serious injury.

- Before working on the power connectors (disconnecting or connecting the cable), disconnect the PSM 510 from the mains and wait for the discharge time to elapse.

WARNING



LEAKAGE/GROUNDING CURRENT HAZARD

Leakage/grounding currents are >3.5 mA. Improper grounding of the ISD 520/DSD 520 servo drives and the system modules may result in death or serious injury.

- For reasons of operator safety, use a certified electrical installer to ground the system correctly in accordance with the applicable local and national electrical standards and directives, and the instructions in this guide.

5.2 Electrical Environmental Conditions

Compliance with the following electrical environmental conditions is necessary to enable safe and effective operation of the servo system:

- Only for use in TN-S, TN-C, TN-CS, TT (not corner earthed) supply earthing system
- Prospective short-circuit current: 5 kA
- Protective class I
- Grounded 3-phase mains network, 400–480 V AC $\pm 10\%$
- 3-phase frequency 44–66 Hz
- 3-phase lines and PE line
- External supply for auxiliary voltage, 24/48 V DC (PELV) $\pm 10\%$
- AC choke (see [5.11.1 AC Line Choke](#))
- Observe the national statutory provisions.
- The leakage current is >3.5 mA.

NOTICE

RCD COMPATIBILITY!

The servo system contains components that can cause a DC current in the protective earthing conductor, which may result in malfunction in any devices connected to the system.

- Where a residual current-operated protective (RCD) or monitoring (RCM) device is used for protection in case of direct or indirect contact, use a type B RCD or RCM device on the supply side of the system components.

NOTICE

- The PSM 510, DAM 510, and optional ACM 510 and EXM 510 must be mounted in a control cabinet.

5.3 EMC-Compliant Installation

To achieve an EMC-compliant installation, follow the instructions provided in [5.5 Grounding for EMC-Compliant Installation](#) and the steps defined for connecting the servo drives, PSM 510, DAM 510, and ACM 510.

5.4 Grounding for Electrical Safety

5.4.1 Grounding the ISD 520 Servo Drive

ISD 520 can be grounded using the flange or the PE screws.

5.4.1.1 Grounding using the Flange

1. Ensure a proper PE connection on the flange surface.

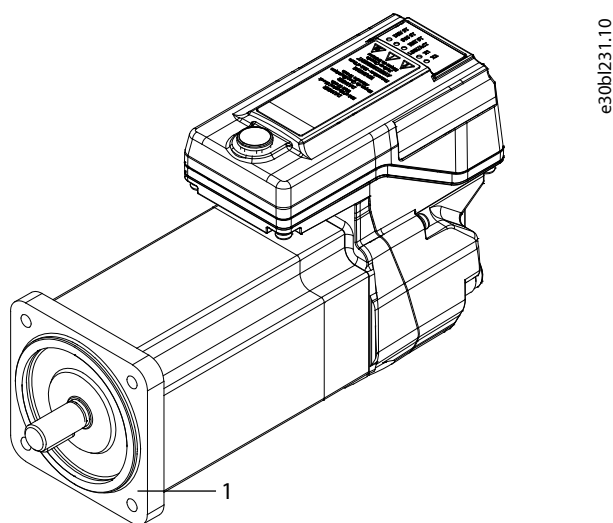

Figure 34: PE Area on the Flange Surface

- 1 PE (motor grounding) area on the ISD 520 servo drive flange

2. Connect the PE yellow/green wire of the feed-in cable to 1 of the PE screws on the front of the DAM 510, as depicted in [Figure 35](#)

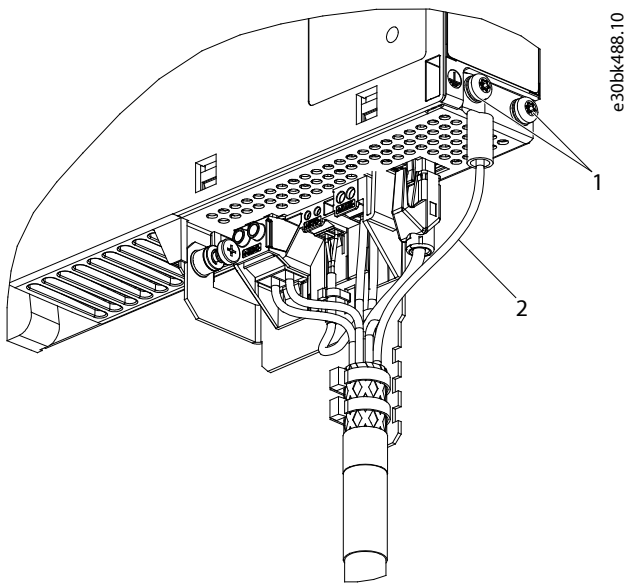

Figure 35: Connecting the PE Wire of the Feed-in Cable

- | | | | |
|---|----------------------|---|---------------------------------|
| 1 | PE screws on DAM 510 | 2 | PE yellow/green wire (fork lug) |
|---|----------------------|---|---------------------------------|

5.4.1.2 Grounding using the PE Screws

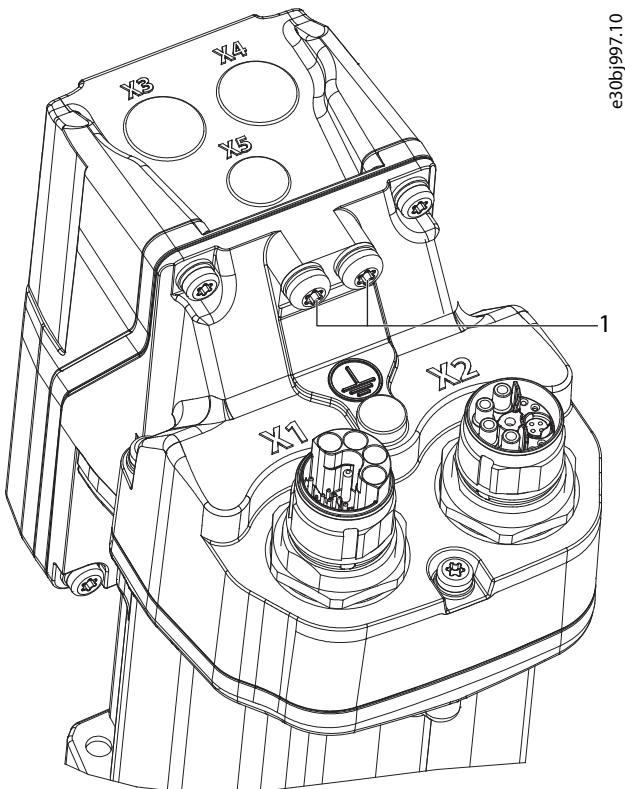

Figure 36: PE Screws on the ISD 520 Servo Drive

- | | |
|---|-----------|
| 1 | PE screws |
|---|-----------|

1. ISD 520 (E0 and E1): Ensure that the machine frame has a proper electrical connection to 1 of the 2 dedicated PE screws (see [Figure 36](#)).

2. ISD 520 (E2): Ensure that the machine frame has a proper electrical connection to the 2 dedicated PE screws (both are needed). As an alternative, a cable with a cross-section of 10 mm²(Cu) can be used.
3. For the ISD 520 servo drives, ensure a minimum ground wire cross-section of at least 4 mm² (minimum 70 °C, Cu).
4. Keep the ground wire connections as short as possible.
5. Connect the PE yellow/green wire of the feed-in cable to 1 of the PE screws on the front of the DAM 510, as depicted in [Figure 35](#).

5.4.2 Grounding the DSD 520 Servo Drive

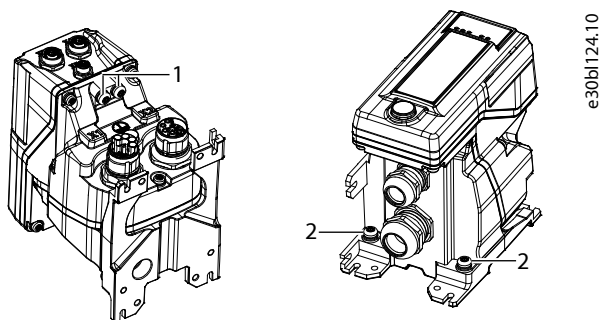

Figure 37: Grounding DSD 520

| | |
|----------------------------------|----------------------------------|
| 1 | 2 |
| PE screws on the DSD 520 housing | PE screws on the DSD 520 adapter |

1. Ensure that the machine frame has a proper electrical connection to 1 of the 2 dedicated PE screws on the housing or on the DSD 520 adapter.
2. For the DSD 520 servo drives, ensure a minimum ground wire cross-section of at least 4 mm² (minimum 70 °C, Cu).
3. Keep the ground wire connections as short as possible.
4. Connect the PE yellow/green wire of the feed-in cable to 1 of the PE screws on the front of the DAM 510 (see [Figure 35](#)).

5.4.3 Grounding the System Modules

Do not ground the system modules in daisy-chain format. Use the grounding method shown in [Figure 38](#).

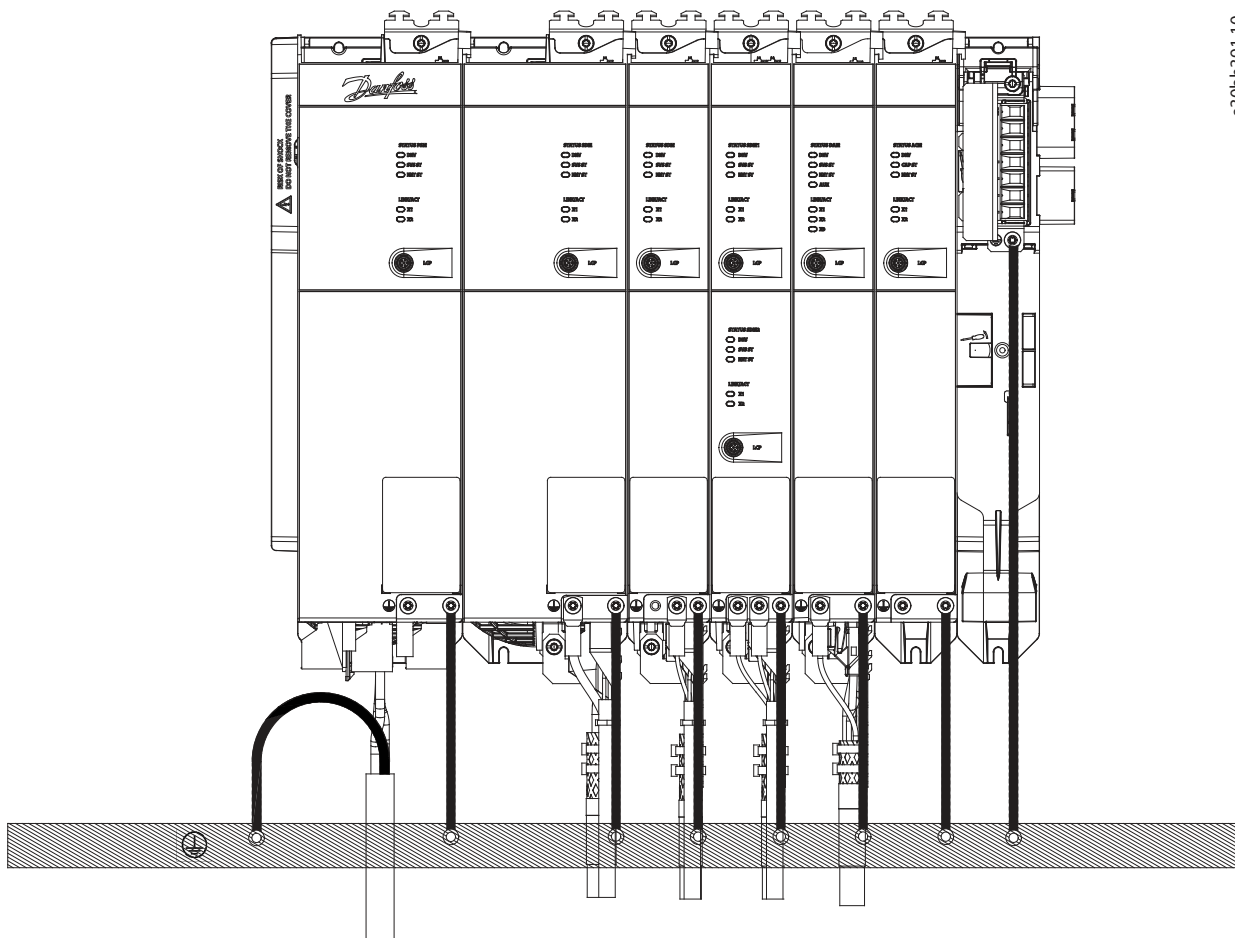

e30bh391.10

Figure 38: Grounding for Electrical Safety

- To comply with CE requirements, ensure a minimum ground wire cross-section of at least 16 mm² (minimum 70 °C, Cu). To comply with UL requirements, ensure a minimum ground wire cross-section of 6 AWG (minimum 60 °C, Cu).
 - If a PSM 510 module with 10 kW is used, the cable cross-section can be reduced to 10 mm² (minimum 70 °C, Cu) to comply with CE requirements and 8 AWG (minimum 60 °C, Cu) to comply with UL requirements.
- Keep the ground wire connections as short as possible.
- Follow the wiring requirements in the VLT® Multiaxis Servo Drive System MSD 510 Operating Guide.

NOTICE

- If 2 separate backlinks are used (connected via 1 or 2 pairs of EXM 510 modules), the 2 grounding bars must also be connected together with a 16 mm² (6 AWG) cable cross-section.

5.5 Grounding for EMC-Compliant Installation

- Establish an electrical connection between the cable shield and the enclosure using the I/O shielding plate on each module.

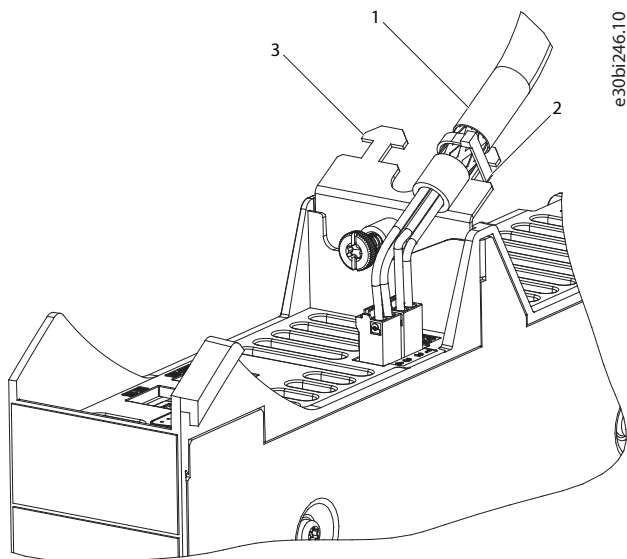

Figure 39: Cable Shielding on the Top of the System Modules

| | | | |
|---|---------------------|---|-----------|
| 1 | Cable | 2 | Cable tie |
| 3 | I/O shielding plate | | |

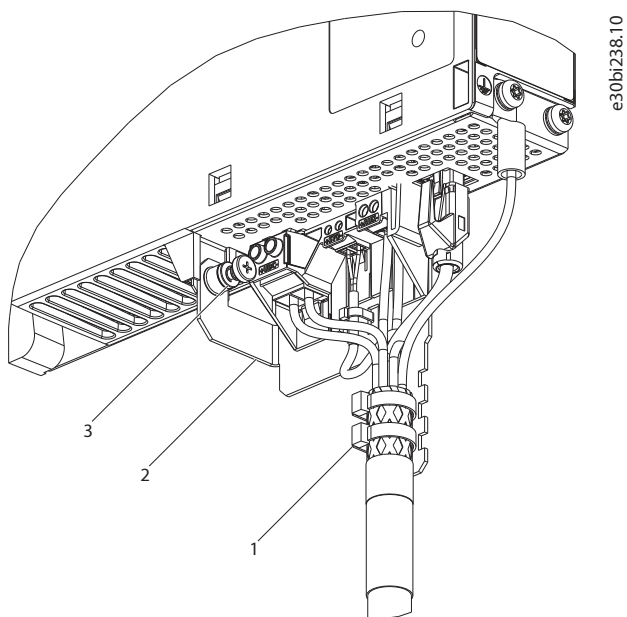

Figure 40: Cable Shielding on the Bottom of the System Modules

| | | | |
|---|-----------------|---|---------------------------|
| 1 | Cable tie | 2 | EMC metal shielding plate |
| 3 | EMC plate screw | | |

- Use a cable with a shielding that has high coverage to reduce electrical interference.
- Do not use pigtails to connect the shielding. A 360° wire connection is recommended.

NOTICE

POTENTIAL EQUALIZATION

- There is a risk of electrical interference when the ground potential between the servo system and the machine is different. Install equalizing cables between them. The recommended cable cross-section is 16 mm².

NOTICE

EMC INTERFERENCE

- Use shielded cables for control wiring and separate cables for power and control wiring. Failure to isolate power and control wiring can result in unintended behavior or reduced performance.
- Ensure a minimum clearance of 200 mm between signal and power cables.
- Only cross cables at 90°.

5.6 Mains Supply Requirements

Ensure that the supply has the following properties:

- TN-S, TN-C, TN-CS, TT (not corner grounded) supply grounding system
- Prospective short-circuit current: 5 kA
- Protective class I
- Grounded 3-phase mains network, 400–480 V AC ±10%
- 3-phase lines and PE line
- 3-phase frequency: 44–66 Hz
- Maximum input current for 1 PSM 510 at 30 kW: 55 A_{rms}

NOTICE

- For information on the use of an IT network with transformer, contact Danfoss.
- Ensure that the servo system is protected either by fuses (see [5.6.1 Fuses](#)) or by a circuit breaker (see [5.6.2 Circuit Breakers](#)).

5.6.1 Fuses

NOTICE

- Use fuses on the supply side of the Power Supply Module (PSM 510) that comply with CE and UL requirements (see [Table 21](#)).
- When 2 PSM 510 modules are used, each PSM 510 must have its own dedicated set of fuses.

Table 21: Fuses

| Model and power rating | CE Compliance (IEC 60364) | UL Compliance (NEC 2014) |
|------------------------|---------------------------|--------------------------|
| | Maximum fuse type | Maximum fuse type |
| PSM 510 (10 kW) | gG 25 A | 30 A (class T or J only) |
| PSM 510 (20 kW) | gG 50 A | 50 A (class T or J only) |
| PSM 510 (30 kW) | gG 63 A | 80 A (class T or J only) |

5.6.2 Circuit Breakers

Use a type B or type C circuit breaker with a capacity of 1.5 times the rated current of PSM 510 to fulfill CE requirements.

NOTICE

- Circuit breakers are not allowed in installations where C-UL is required. Only UL-recommended fuses are allowed.

5.6.3 Additional Specifications

Table 22: Additional Specification

| | |
|---|---|
| Maximum imbalance temporary between mains phase | 3% of the rated supply voltage |
| True power factor [λ] | ≥ 0.9 at rated current |
| Switching on input supply | Maximum 2 times per minute |
| Mains dropout | During low mains or a mains dropout, the PSM 510 and the servo drives keep running until the DC-link voltage drops below 373 V. Full torque of the servo drives cannot be expected at a mains voltage 10% below the rated supply voltage. |

5.7 Auxiliary Supply Requirements

Supply the Power Supply Module (PSM 510) with a power supply unit with an output of 24/48 V DC $\pm 10\%$. The output ripple of the power supply unit must be $< 250 \text{ mV}_{pp}$.

NOTICE

- Only use supply units that conform to the PELV specification.
- Use a supply that is CE-marked according to the standards EN 61000-6-2 and EN 61000-6-4 or similar for industrial use.
- Ensure that the secondary circuit is supplied from an external isolated source.

The power supply unit must be dedicated to the ISD 520/DSD 520 servo system, meaning that the supply is used exclusively for powering the PSM 510. The maximum allowed cable length between the supply unit and the PSM 510 is 3 m.

NOTICE

- For cable lengths $< 10 \text{ m}$, use 24 V auxiliary voltage. For cable lengths $\geq 10 \text{ m}$, use 48 V auxiliary voltage.
- If a mechanical brake is connected, always supply the servo system with 48 V auxiliary voltage.

5.7.1 Fuses

UL listed fuses are recommended to protect the wiring on 24/48 V DC.

Table 23: Fuses

| CE Compliance (IEC 60364) | UL Compliance (NEC 2014) |
|---------------------------|--------------------------|
| Maximum fuse type | Maximum fuse type |
| 50 A ⁽¹⁾ | 63 A ⁽²⁾ |

1) If the maximum current is lower, a fuse with a lower current rating can be used. Rating of IEC fuses: according to 100% of maximum current. Use a time delay fuse rated according to the DC voltage used.

2) If the maximum current is lower, a fuse with a lower current rating can be used. Rating of UL fuses: according to 125% of maximum current. Use a time delay fuse rated according to the DC voltage used.

5.8 Safety Supply Requirements

Supply the STO line with a 24 V DC supply with the following properties:

- Output range: 24 V DC $\pm 10\%$

- Maximum current: 1 A

The maximum current is the maximum allowed current throughout the system. The typical current depends on the system topology and dimensioning.

Use a 24 V supply unit that is CE-marked for industrial use. Ensure that the supply fulfills the PELV specification and is only used for the system safety input.

A common supply for auxiliary and safety supply can be used, however the only connection point of the 2 circuits must be near to the supply to avoid interference from a common voltage drop. The maximum cable length between the 24 V supply unit and the servo system is 3 m.

The safety supply can be looped from PSM 510 to the other system modules except for ACM 510. The cable for this is not provided. See [8.6 Installation](#) for further information.

NOTICE

- Ensure that there is reinforced isolation between safety signals and other signals, supplies (mains supply), and exposed conductive parts.

5.9 UL Requirements

NOTICE

- Integral solid-state short-circuit protection does not provide branch circuit protection. Branch circuit protection must be provided in accordance with the National Electrical Code/Canadian Electrical Code, and any additional local codes or equivalent.
- Suitable for use on a circuit capable of delivering not more than 5000 rms symmetrical amperes, 480 V maximum when protected by maximum 80 A class J or T fuses.
- To meet the UL (Underwriters Laboratories) regulations, use a UL-approved copper cable with a minimum heat-resistance of 60 °C. Use Class 1 wire only. For PSM 510 rated 30 kW and EXM 510, use a minimum heat resistance of 75 °C.
- Control Circuit Overcurrent Protection is required.

5.10 Connecting the ISD 520/DSD 520 Servo Drive

5.10.1 Electrical Installation Warnings for ISD 520/DSD 520 Servo Drive

WARNING



HIGH VOLTAGE

Potentially lethal voltage is present on the connectors that may lead to death or serious injury.

- Before working on the power or signal connectors (disconnecting or connecting the cable), or performing any maintenance work, disconnect the Power Supply Module (PSM 510) from the mains and wait for the discharge time to elapse.

WARNING

DISCHARGE TIME

The servo system contains DC-link capacitors that remain charged for some time after the mains supply is switched off at the Power Supply Module (PSM 510). Failure to wait the specified time after power has been removed before performing service or repair work could result in death or serious injury.

- To avoid electric shock, fully disconnect the Power Supply Module (PSM 510) from the mains and wait for the capacitors to fully discharge before carrying out any maintenance work on the servo system or replacing components.

Minimum waiting time (minutes)

 15

DANGER

RISQUE DU CHOC ÉLECTRIQUE

Une tension dangereuse peut être présentée jusqu'à 15 min après avoir coupé l'alimentation.

NOTICE

- Use a motor with reinforced insulation between the thermistor and the motor windings (tested with 4300 V DC and 8000 V_{peak} impulse).
- Use a motor with reinforced insulation between the brake and the motor windings (tested with 4300 V DC and 8000 V_{peak} impulse).

5.10.2 General Instructions for Cable Installation

Avoid mechanical tension for all cables, especially regarding the range of motion of the installed servo drive.

Secure all cables in accordance with regulations and depending on conditions on site. Ensure that cables cannot come loose, even after prolonged operation.

If the X3, X4, and X5 connectors are not used, always mount the corresponding blind cap.

NOTICE

- Never connect or disconnect the hybrid cables to or from the servo drive when the supply voltage is present. Doing so damages the electronic circuitry. Observe the discharge time for the DC-link capacitors.
- Do not forcefully connect or fit the connectors. Incorrect connection causes permanent damage to the connector.
- Use cables with a suitable insulation (minimum 0.4 mm for power cables and minimum 0.2 mm for signal cables).

Table 24: Tightening Torques

| Connector | Tightening torque [Nm] |
|-----------|------------------------|
| M8 | 0.2 |
| M12 | 0.4 |
| M23 | 0.8 |

5.10.3 Connecting Hybrid Cables

Procedure

1. Align the female connector of the M23 feed-in cable to the male input connector (X1) of the 1st ISD 520/DSD 520 servo drive.
2. Fully rotate the threaded ring of the cable connector counterclockwise. Use the marking OPEN as a reference for the cable connector.
3. Ensure the marking OPEN on the cable connector is facing the servo drive.
4. Press the connector towards the electronic housing on the servo drive until the sealing on the connector is entirely covered.
5. Tighten the M23 feed-in cable connector by rotating the threaded ring clockwise out of the flat area around the OPEN marking.

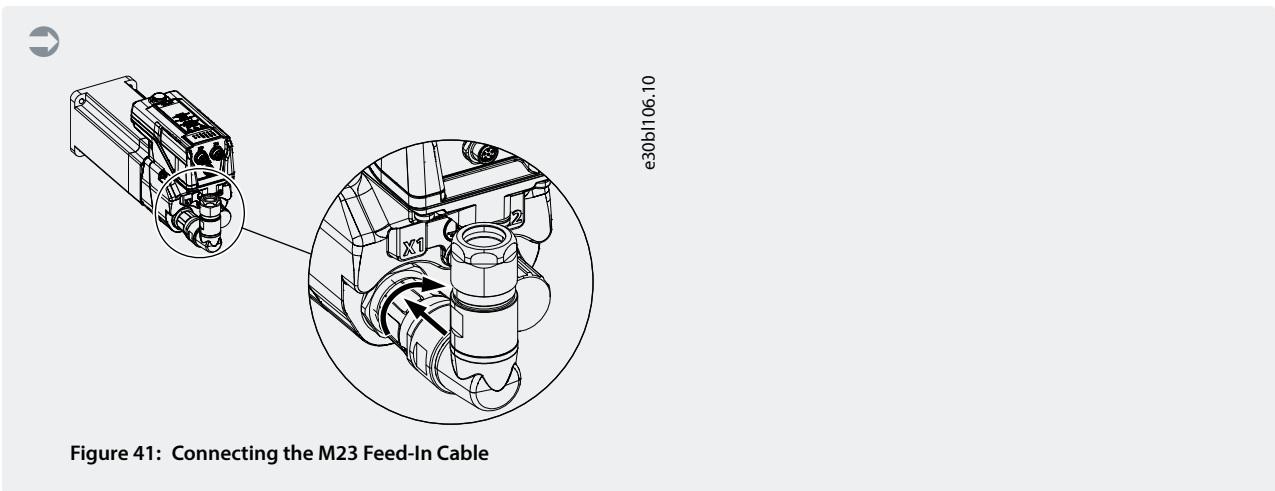

Figure 41: Connecting the M23 Feed-In Cable

6. To add more servo drives in daisy-chain format, connect the male connector of the loop cable to the female connector (X2) of the 1st servo drive.
7. Connect the female connector of the loop cable to the male connector (X1) of the next servo drive, and so on.
8. Tighten the threaded rings by hand as described in step 5.
9. Ensure that there is no mechanical tension on the cables.

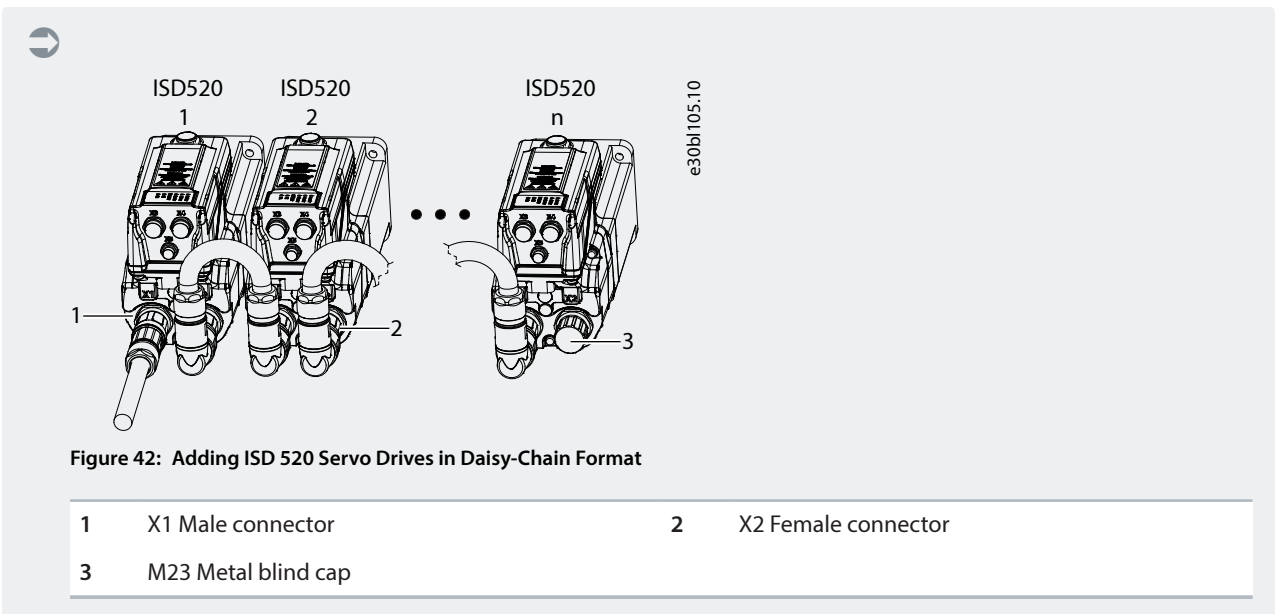

Figure 42: Adding ISD 520 Servo Drives in Daisy-Chain Format

| | | | |
|---|---------------------|---|---------------------|
| 1 | X1 Male connector | 2 | X2 Female connector |
| 3 | M23 Metal blind cap | | |

10. Screw the M23 metal blind cap onto the unused M23 female output connector (X2) on the last servo drive in the servo system.
11. Tighten the metal blind cap until the sealing on the connector is covered.

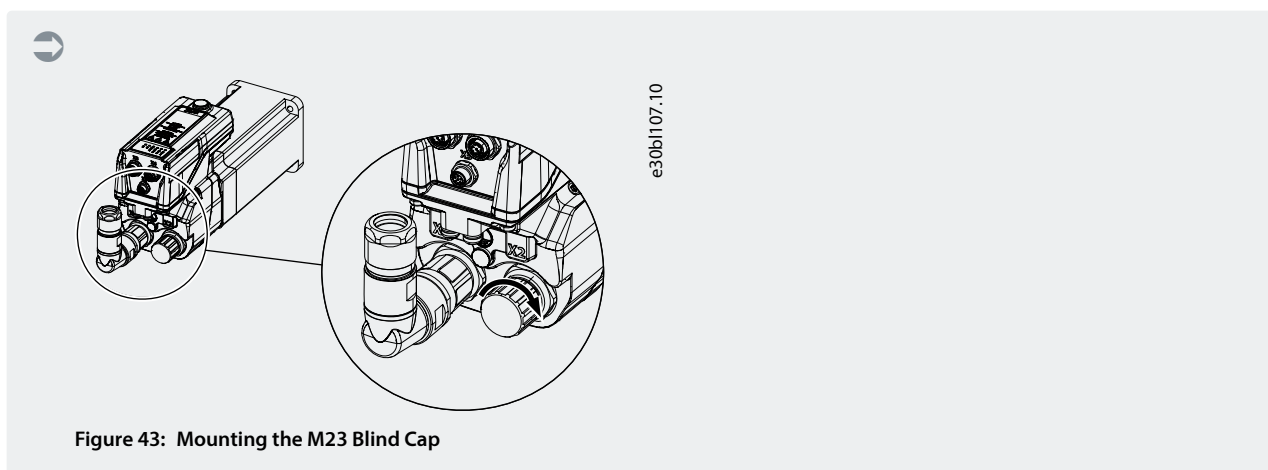

Figure 43: Mounting the M23 Blind Cap

CAUTION

RISK OF INJURY AND/OR EQUIPMENT DAMAGE

Failure to use the M23 metal blind cap may result in injury to the operator and/or damage to the ISD 520/DSD 520 servo drive.

- Always fit the M23 metal blind cap as described in steps 10 and 11.

NOTICE

- A straight version of the M23 connector is also available. The procedure for connecting the straight M23 connector is the same as for the angled connector.

5.10.4 Disconnecting Hybrid Cables

Procedure

1. Disconnect the Power Supply Module (PSM 510) from its power source (mains network and U_{AUX}).
2. Wait for the minimum discharge time to elapse.
3. Remove the connector of the feed-in cable from the Decentral Access Module (DAM 510).
4. Rotate the threaded ring on the feed-in cable connector on the servo drive counterclockwise until the marking OPEN on the cable connector is facing the servo drive.
5. Pull the connector away from the electronic housing.
6. Protective metal M23 blind caps are provided for the X1 and X2 connectors. Mount the metal blind caps after removing the corresponding connector.

5.10.5 Connecting Cables to Ports X3, X4, and X5

5.10.5.1 Cable Routing Recommendations

Avoid mechanical tension for all cables, especially regarding the range of motion of the installed servo drive.

Secure all cables in accordance with regulations and depending on conditions on site. Ensure that cables cannot come loose, even after prolonged operation.

5.10.5.2 Connecting I/O Cables to Ports X3 and X4

Procedure

1. Align the connector on the cable (not supplied) with the connector marked X3 or X4 on the servo drive.

- Press the connector towards the electronic housing of the servo drive and tighten the threaded ring of the connector by turning it clockwise. The maximum tightening torque is 0.4 Nm.

5.10.5.3 Connecting the LCP Cable to Port X5

Procedure

- Align the connector on the LCP cable (not supplied) with the LCP connector marked X5 on the ISD 520/DSD 520 servo drive.
- Press the connector towards the electronic housing of the servo drive and tighten the threaded ring of the connector by turning it clockwise. The maximum tightening torque is 0.2 Nm.

The LCP cable can be ordered as an accessory.

5.10.6 Disconnecting Cables from Ports X3, X4, and X5

- Loosen the threaded ring of the connector by turning it counterclockwise.
- Disconnect the cable from the servo drive.
- Protective blind caps are provided for the X3, X4, and X5 connectors. Mount the blind caps after removing the respective connector.

5.10.7 Connecting the Wires on DSD 520

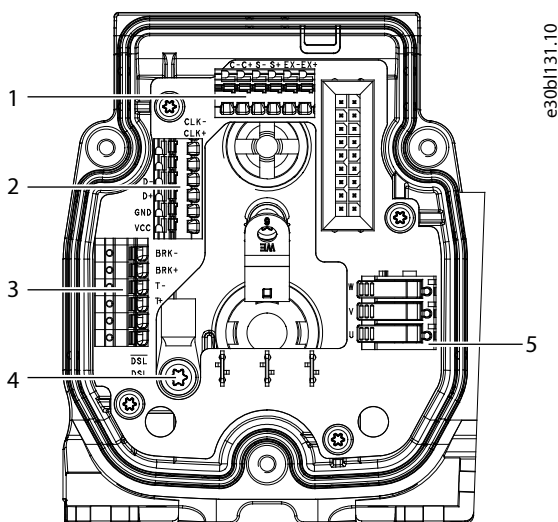

Figure 44: Connecting the Wires on DSD 520

| | | | |
|---|--|---|----------------------------------|
| 1 | Analog motor feedback connector | 2 | Digital motor feedback connector |
| 3 | Thermistor, mechanical brake, and HIPERFACE® DSL connector | 4 | PE screw |
| 5 | Motor phase connector | | |

5.11 Connecting the Power Supply Module PSM 510

5.11.1 AC Line Choke

It is mandatory to use a 3-phase AC line choke (see [5.11.1.1 Connecting 1 PSM 510 to the AC Choke](#) and [5.11.1.2 Connecting 2 PSM 510 Modules to the AC Choke](#)).

Table 25: Line Choke Characteristics for 1 PSM 510

| Model | Minimum I_{rms} [A] | U_{rms} [V] | Inductance [mH] |
|-----------------|-----------------------|---------------|--------------------------------|
| PSM 510 (10 kW) | 20 | 500 | Minimum: 0.47 Maximum: 1.47 |
| PSM 510 (20 kW) | 40 | 500 | Minimum: 0.47 Maximum: 1.47 |
| PSM 510 (30 kW) | 60 | 500 | 0.47 \pm 10% |

If 2 PSM 510 modules are installed in parallel, use an AC choke as specified in [Table 26](#). See [5.11.1.2 Connecting 2 PSM 510 Modules to the AC Choke](#) for further information.

Table 26: Line Choke Characteristics for 2 PSM 510 installed in parallel

| Model | Minimum I_{rms} [A] | U_{rms} [V] | Inductance [mH] |
|---------------------|-----------------------|---------------|-----------------|
| PSM 510 (2 x 30 kW) | 125 | 500 | 0.24 \pm 10% |

Danfoss recommends mounting the AC line choke close to the PSM 510.

The maximum cable length depends on the cross-section, and the required voltage and current at the DC link.

If the AC line chokes are mounted away from the PSM 510, the maximum cable distance is 5 m.

5.11.1.1 Connecting 1 PSM 510 to the AC Choke

Connect the PSM 510 to the electric grid with the correct AC choke for the power size of the PSM 510.

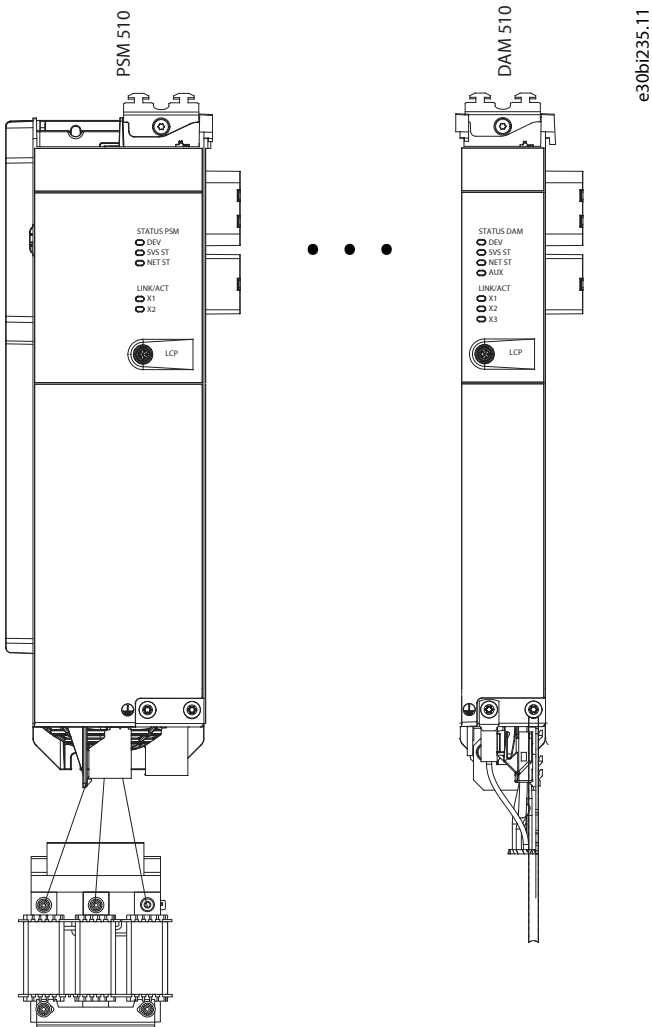

e30bi235.11

Figure 45: Connecting 1 PSM 510 to the AC Choke

5.11.1.2 Connecting 2 PSM 510 Modules to the AC Choke

Connect the PSM 510 modules to the same AC choke as shown in [Figure 46](#).

Ensure that the choke used is the correct size based on the combined power of the PSM 510 modules.

When 2 PSM 510 modules are used, the wiring between the AC line choke and each PSM 510 must be the same length within a tolerance of 0.5 m.

Connect each PSM 510 to the AC choke directly. Parallel wiring is not allowed.

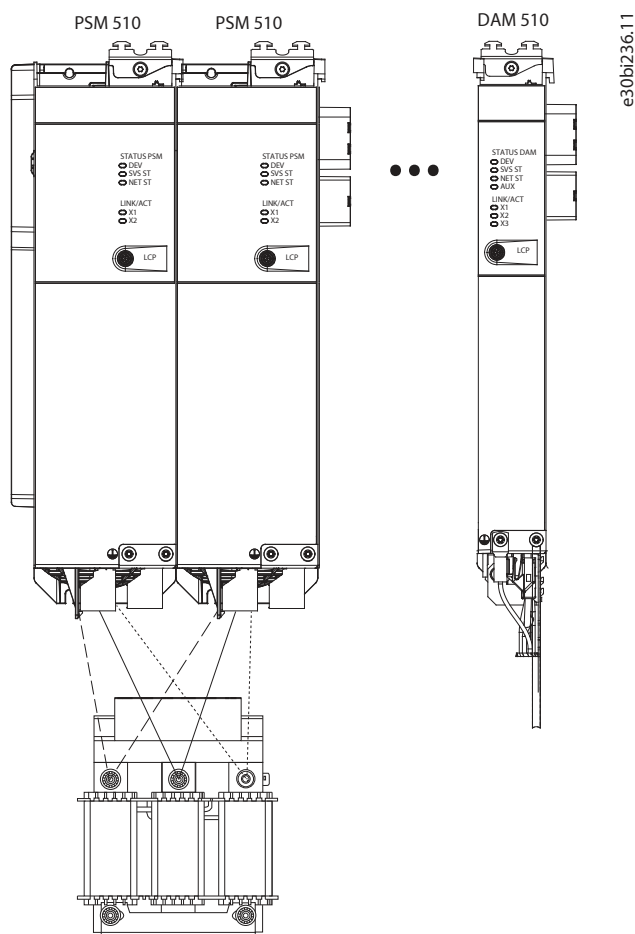

Figure 46: Connecting 2 PSM 510 Modules to the AC Choke

5.11.1.3 Connecting 2 PSM 510 Modules to the AC Choke with System Splitting

Connect the PSM 510 modules to the same AC choke regardless of the load position (for example, before or after the system splitting) as shown in [Figure 47](#).

Ensure the choke used is the correct size based on the combined power of the PSM 510 modules.

When 2 PSM 510 modules are used, the wiring between the AC line choke and each PSM 510 must be the same length within a tolerance of 0.5 m.

Connect each PSM 510 to the AC choke directly. Parallel wiring is not allowed.

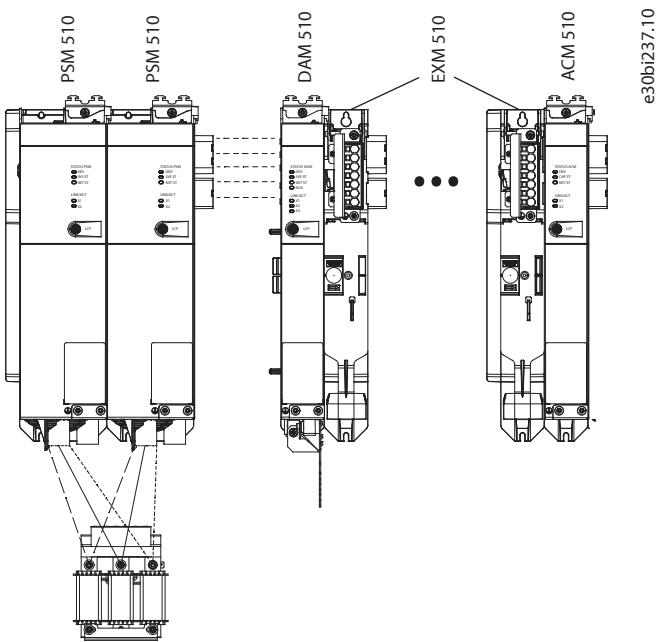

Figure 47: Connecting 2 PSM 510 Modules to the AC Choke with System Splitting

If 2 AC chokes are used (1 per PSM 510) and both PSM 510 modules are mounted at the same side of the system splitting, the setup is allowed with derating equal to the AC choke's tolerance referred to 60 kW. For example, 10% derating is 54 kW.

If 2 AC chokes are used (1 per PSM 510) where 1 PSM 510 module is mounted before the splitting and 1 after the splitting, the loads must be balanced equally. Otherwise, the derating of both PSM 510 modules is equal to the AC choke's tolerance. For example, tolerance 10% + 10% means -20% derating.

If 2 AC chokes are used (1 per PSM 510) and 1 PSM 510 module is mounted before the splitting and 1 after the splitting and half of the loads are set before the system splitting and half are set after the system splitting, the setup is allowed with derating equal to the tolerance of the AC choke referred to 60 kW. For example, 10% derating is 54 kW.

NOTICE

- Further information on the EXM 510 module and wiring can be found in [11.9.13 Expansion Module Connector](#).

5.12 Connecting the Cables on the Power Supply Module PSM 510

5.12.1 Connecting the Cables on the Top of the Power Supply Module PSM 510

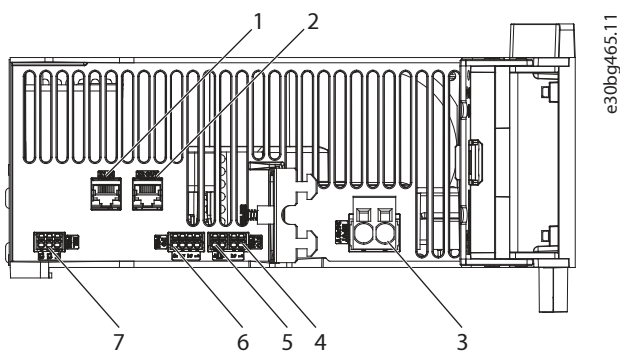

Figure 48: Connectors on the Top of PSM 510

| | | | |
|---|--------------------------------------|---|---------------------------------|
| 1 | Ethernet connector IN (X1 IN) | 2 | Ethernet connector OUT (X2 OUT) |
| 3 | 24/48 V IN connector (INPUT 24/48 V) | 4 | STO connector IN (STO PSM) |

- | | | | |
|---|-----------------------------|---|-------------------------|
| 5 | STO connector OUT (STO PSM) | 6 | I/O connector (I/O PSM) |
| 7 | Relay connector (REL PSM) | | |

Procedure

1. Connect the Ethernet cable from the PLC to the Ethernet input connector (X1 IN) [1].
2. Connect the Ethernet cable from the Ethernet output connector (X2 OUT) [2] to the next module.
3. Insert the wires into the 24/48 V IN (INPUT 24/48 V) connector.
4. Insert the 24/48 V IN connector [3].
5. Insert the wires into the STO connector IN (STO PSM) connector.
6. Insert the STO connector IN connector [4].
7. Insert the wires into the STO connector OUT (STO PSM) connector.
8. Insert the STO connector OUT connector [5].
9. If I/Os are required, insert the wires into the I/O connector and insert the connector (I/O PSM) [6].
10. If a relay is required, insert the wires into the relay connector and insert the connector (REL PSM) [7].

5.12.2 Connecting the Cables on the Bottom of the Power Supply Module PSM 510

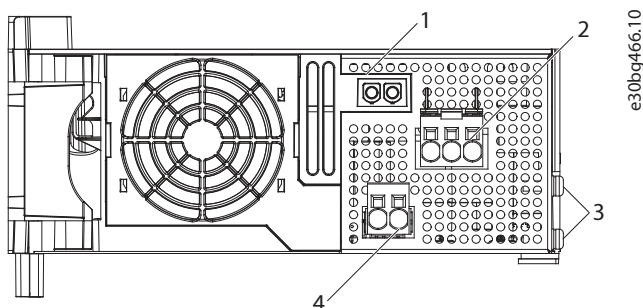

Figure 49: Connectors on the Bottom of PSM 510

| | | | |
|---|--|---|--|
| 1 | Holder for internal brake resistor connector when not in use | 2 | AC mains supply connector |
| 3 | PE screws | 4 | Internal/external brake resistor connector |

Procedure

1. Insert the wires into the AC mains supply connector.
2. Insert the AC mains supply connector [2].
3. If an external brake resistor is required:
 - a. Unplug the internal brake resistor connector [4] and insert the external brake connector in its place.
 - b. Plug the internal brake resistor connector to the internal brake connector holder [1].
4. Connect the PSM 510 to PE using 1 of the PE screws on the front side [3] and a PE wire. The tightening torque is 3 Nm.

5.13 Connecting the Decentral Access Module DAM 510

5.13.1 Connecting the Cables on the Top of the Decentral Access Module DAM 510

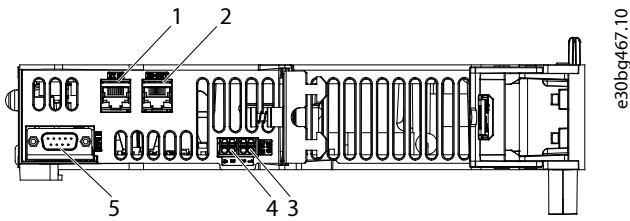

Figure 50: Connectors on the Top of DAM 510

| | | | |
|---|------------------------------------|---|---------------------------------|
| 1 | Ethernet connector IN (X1 IN) | 2 | Ethernet connector OUT (X3 OUT) |
| 3 | STO connector IN (STO DAM) | 4 | STO connector OUT (STO DAM) |
| 5 | External encoder connector (E DAM) | | |

Procedure

1. Connect the Ethernet cable from the output of the previous module to the input connector (X1 IN) [1].
2. Insert the wires from the STO output of the previous module into the 24 V IN (STO input) connector, see [11.9.9.2.1 STO Connectors on the Top of DAM 510](#).
3. Insert the 24 V IN (STO connector IN (STO DAM)) connector [3] into the DAM 510.
4. If required, connect the external encoder connector [5].

5.13.2 Connecting the Feed-In Cable

Prerequisite:

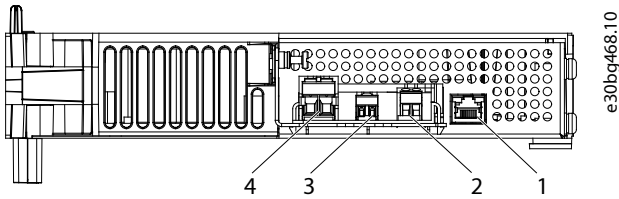

Figure 51: Connectors on the Bottom of DAM 510

| | | | |
|---|--------------------|---|---------------|
| 1 | Ethernet connector | 2 | AUX connector |
| 3 | STO out connector | 4 | UDC connector |

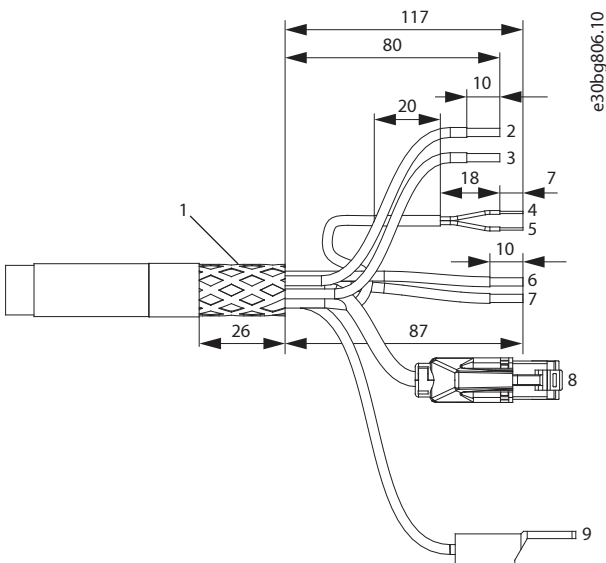

Figure 52: Feed-In Cable

| | | | |
|---|--|---|---|
| 1 | Shielded area | 2 | UDC+ (black, 2.5 mm ² /4 mm ²) |
| 3 | UDC- (gray, 2.5 mm ² /4 mm ²) | 4 | STO+ (pink, 0.5 mm ²) |
| 5 | STO- (gray, 0.5 mm ²) | 6 | AUX+ (red, 2.5 mm ²) |
| 7 | AUX- (blue, 2.5 mm ²) | 8 | Ethernet/fieldbus (green, RJ45 connector) |
| 9 | PE (yellow/green, 2.5 mm ² /4 mm ² , fork lug) | | |

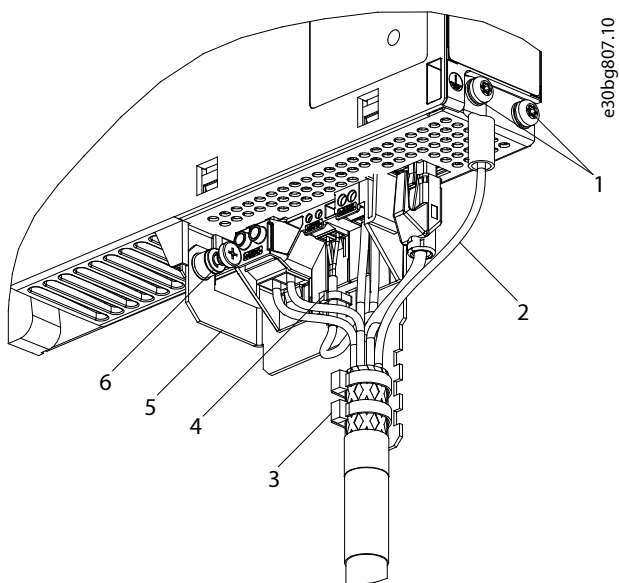

Figure 53: Connecting the Feed-In Cable

| | | | |
|---|-----------------------------|---|-------------------------|
| 1 | Feed-in cable PE screws | 2 | Bus connector |
| 3 | Cable tie for feed-in cable | 4 | Cable tie for STO cable |
| 5 | EMC plate | 6 | EMC plate screw |

Procedure

1. Insert the wires into the UDC, AUX, and STO connectors.
2. Secure the feed-in cable using the cable ties [3], ensuring that the shielded area is positioned exactly under the cable tie.
3. Secure the STO cable using the cable tie [4], ensuring that the shielded area is positioned exactly under the cable tie.
4. Insert the connectors on the feed-in cable into their corresponding terminal block on the DAM 510.
5. Tighten the screw on the EMC plate [6]. The tightening torque is 3 Nm.
6. Insert the RJ45 bus connector [2].
7. Connect the DAM 510 to PE using one of the PE screws on the front side [1] and a PE wire. The tightening torque is 3 Nm.
8. Connect the PE wire of the feed-in cable to the other PE screw on the DAM 510.

5.14 Connecting the Auxiliary Capacitors Module ACM 510

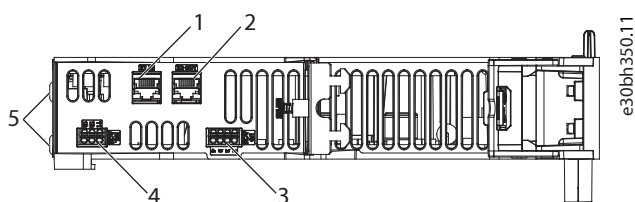

Figure 54: Connectors on the Top of ACM 510

| | | | |
|---|-------------------------------|---|---------------------------------|
| 1 | Ethernet connector IN (X1 IN) | 2 | Ethernet connector OUT (X2 OUT) |
| 3 | I/O connector (I/O ACM) | 4 | Relay connector (REL ACM) |

Procedure

1. Connect the Ethernet cable from the output of the previous system module to the input connector (X1 IN) [1].
2. If I/Os are required, insert the wires into the I/O connector (I/O ACM) and insert the connector [3].
3. If a relay is required, insert the wires into the relay connector (REL ACM) and insert the connector [4].
4. Connect the ACM 510 to PE using one of the PE screws on the front side [5] and a PE wire. The tightening torque is 3 Nm.

5.15 Connecting the Expansion Module EXM 510

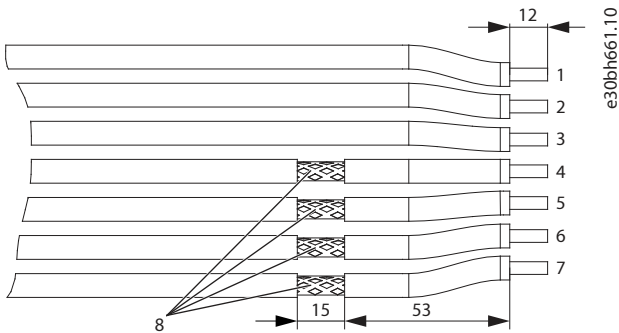

Figure 55: Expansion Module Cable

| | | | |
|---|------------------|---|---------------|
| 1 | 24/48 V | 2 | GND |
| 3 | Functional earth | 4 | DC- |
| 5 | DC- | 6 | DC+ |
| 7 | DC+ | 8 | Shielded area |

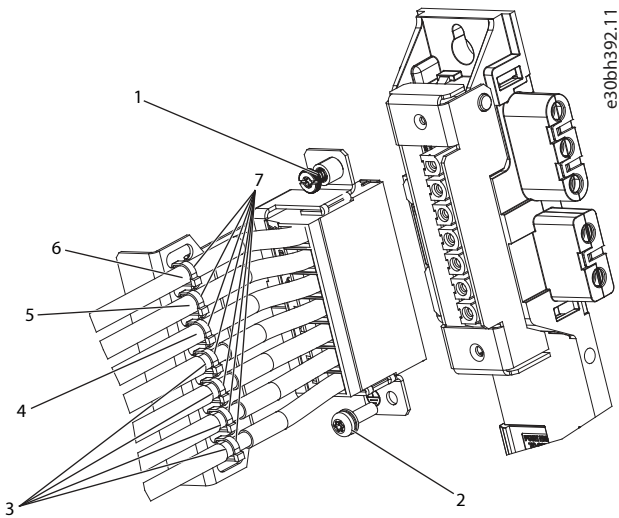

Figure 56: Connecting the Expansion Module EXM 510

| | | | |
|---|---------------------------|---|------------------------|
| 1 | EMC shielding plate screw | 2 | PE screw |
| 3 | DC cables | 4 | Functional earth cable |
| 5 | GND cable | 6 | 24/48 V cable |
| 7 | Cable ties | | |

NOTICE

- If 2 separate backlinks are used (connected via 1 or 2 pairs of EXM 510 modules), the 2 grounding bars must be also connected together with a 16 mm² (6 AWG) cable cross-section.
- For cable cross-sections, see [11.9.13.1 Cable Cross-sections for EXM 510](#).

1. Insert wires [3], [4], [5], and [6] into the expansion connector.
2. Secure the DC cables [3] using the cable ties [7], ensuring that the shielded area is positioned exactly under the cable tie.
3. Secure the cables [4], [5], and [6] using the cable ties [7].
4. Plug the connectors into the backplate.
5. Tighten the screw on the EMC shielding plate [1]. The tightening torque is 3 Nm.
6. Connect the EXM 510 to PE using the PE screw [2] and a PE wire. The tightening torque is 3 Nm.

5.16 Connecting the Brake Resistor on the PSM 510

The PSM 510 is connected to the internal brake resistor as shown in [Figure 57](#).

Alternatively, the PSM 510 can be connected to an external brake resistor. In this case, the internal brake resistor on the PSM 510 must remain unconnected and the connector can be placed in the internal brake resistor connector holder.

Paralleling or series of brake resistors is not allowed.

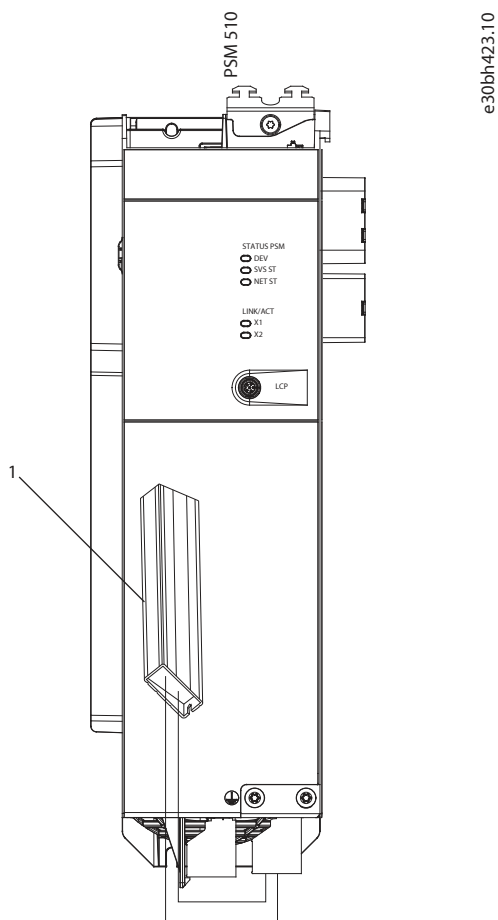

Figure 57: Connection of Internal Brake Resistor on 1 PSM 510

| | |
|---|-------------------------|
| 1 | Internal brake resistor |
|---|-------------------------|

When using 2 PSM 510 modules, connect each PSM 510 to its own internal brake resistor as shown in [Figure 58](#) (factory setting).

Alternative allowed configurations for 2 PSM 510 modules:

- 1 PSM 510 is connected to the internal brake resistor and the other is connected to an external brake resistor.
- Both PSM 510 modules are connected to an external brake resistor. In this case, the internal brake resistor on the PSM 510 must remain unconnected and the connector can be placed in the internal brake resistor connector holder (see [5.12.2 Connecting the Cables on the Bottom of the Power Supply Module PSM 510](#)).

Paralleling or series of brake resistors is not allowed.

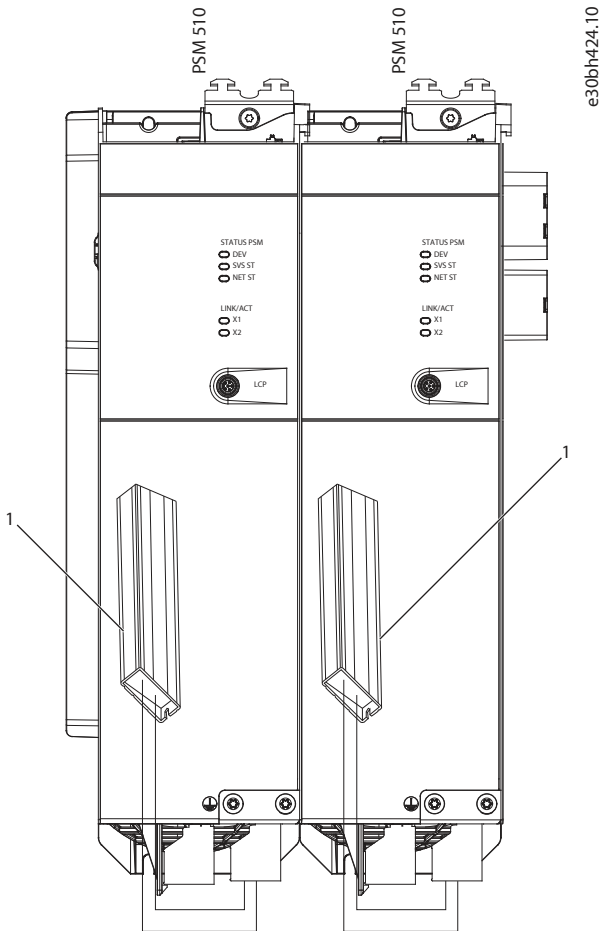

Figure 58: Connection of Brake Resistor on 2 PSM 510 Modules in Parallel

| | |
|---|-------------------------|
| 1 | Internal brake resistor |
|---|-------------------------|

6 Commissioning

6.1 Warnings for Commissioning

WARNING

UNINTENDED START

The servo system contains servo drives, the PSM 510, and DAM 510 that are connected to the electrical supply network and can start running at any time. This may be caused by a fieldbus command, a reference signal, or clearing a fault condition. Servo drives and all connected devices must be in good operating condition. A deficient operating condition may lead to death, serious injury, damage to equipment, or other material damage when the unit is connected to the electrical supply network.

- Take suitable measures to prevent unintended starts.

6.2 Pre-Commissioning Checklist

Always complete these checks before initial commissioning and before commencing operation after extended downtime or storage.

Procedure

1. Check that all the threaded connectors of mechanical and electrical components are firmly tightened.
2. Check that the free circulation of cooling air (inlet and outlet) is assured.
3. Check that the electrical connections are correct.
4. Ensure that contact protection is in place for rotating parts and surfaces that can become hot.
5. If using the STO functionality, conduct the functional safety concept commissioning test (see [8.8 Commissioning Test](#)).

6.3 EtherCAT® ID Assignment

EtherCAT® needs no special ID assignment (IP address). Special ID assignment is only required when using indirect communication via the VLT® Servo Toolbox software.

6.4 Ethernet POWERLINK® ID Assignment

6.4.1 Overview

Ethernet POWERLINK® master communication must not be active when using the VLT® Servo Toolbox to assign IDs to the devices. ID assignment via the VLT® Servo Toolbox is only possible when acyclic Ethernet POWERLINK® communication is used. If Ethernet POWERLINK® cyclic communication is already started, perform a power cycle to stop it.

Detach the PLC and carry out a power cycle before setting IDs. Alternatively, in the POWERLINK® interface, restart the PLC in Service Mode while parameter **Basic Ethernet** in *Service Mode* is set to *Basic Ethernet enabled*.

6.4.2 Single Device ID Assignment

When assigning an ID to a single device, use the *Device Information* window in the VLT® Servo Toolbox (see the *VLT® Servo Drive System ISD 520, DSD 520, MSD 520 (VLT® FlexMotion™) Programming Guide* for further information).

Setting an ID to a device can also be done via the LCP.

6.4.2.1 Setting the Node ID Directly on a Servo Drive or on the System Modules

All IP-related parameters are in parameter group **12-0* IP Settings**. According to the Ethernet POWERLINK® standard, the IP address is fixed to 192.168.100.xxx. The last number is the value in parameter **12-60 Node ID**. For parameter **12-02 Subnet Mask**, the IP address is fixed to 255.255.255.0 and cannot be changed.

Procedure

1. Attach the LCP to the servo drive or system module for which the *Node ID* should be changed.

2. Press *[Hand On]* for >1 s to make the LCP the controlling interface.
3. Press *[Main Menu]* then scroll down to parameter group **12-** Ethernet** and press *[OK]*.
4. Scroll down to parameter group **12-6* Ethernet POWERLINK** and press *[OK]*.
5. Change the PSM 510/DAM 510 node ID to the desired value (1–239).
6. Press *[OK]* to confirm the selection then wait for the ID assignment procedure to complete.
7. Carry out a power cycle to ensure that all ID changes are in effect and operational on the fieldbus.

6.4.2.2 Setting the Node ID for a Single Servo Drive via the Power Supply Module (PSM 510) or Decentral Access Module (DAM 510) using the LCP

It is also possible to change the *Node ID* of a servo drive when the LCP is connected to the PSM 510 or DAM 510. This functionality is contained in parameter group **54-** ID Assignment** in subgroup **54-1* Manual**.

Procedure

1. Attach the LCP to the PSM 510/DAM 510 that is connected to the servo drives and system modules for which the *Node ID* should be changed.
2. Press *[Hand On]* for >1 s to make the LCP the controlling interface for the PSM 510/DAM 510.
3. Press *[Main Menu]* then scroll down to parameter group **12-** Ethernet** and press *[OK]*.
4. Scroll down to parameter group **12-6* Ethernet POWERLINK** and press *[OK]*.
5. Change the PSM 510/DAM 510 node ID to the desired value (1–239) by pressing *[OK]*.
6. Return to the *Main Menu* and select parameter group **54-** ID Assignment**.
7. Select parameter group **54-1* Manual**.
8. PSM 510 only: In parameter **54-01 Epl id assignment line**, select either Ethernet port X1 or X2. The PSM 510 assigns IDs to the selected device via the selected port and the fieldbus network. On DAM 510 port, X2 is used automatically.
9. Select parameter **54-12 Epl ID assignment start id** then select a valid value (1–239). The value is assigned to the device at the specified position index. The PSM 510/DAM 510 connected to the LCP is at position 0 and the 1st reachable device on the selected port is position index 1 and so on.
10. Select parameter **54-14 Manual Epl ID assignment start** and change the status from *[0] ready* to *[1] start*.
11. Press *[OK]* to confirm the selection then wait for the ID assignment procedure to complete.
12. Check that the ID assignment was completed successfully using parameters:
 - a. Parameter **54-15 Epl ID assignment state**
 - b. Parameter **54-16 Epl ID assignment error code**
 - c. Parameter **54-17 Epl ID assignment device count**
13. Carry out a power cycle to ensure that all ID changes are in effect and operational on the fieldbus.

➡ If an error occurs during ID assignment, the detected error is shown on the LCP. The following errors may be reported:

- Invalid NMT state
- Invalid comment
- Invalid Ethernet port
- Invalid node ID
- ID assignment failed
- Duplicate MAC address
- Invalid SW version
- Incomplete assignment

- No device found
- Internal error

6.4.3 Multiple Device ID Assignment

When assigning IDs to several devices (for example, when setting up a new network), use the VLT® Servo Toolbox subtool *DAM ID assignment* (see the *VLT® Servo Drive System ISD 520, DSD 520, MSD 520 (VLT® FlexMotion™) Programming Guide* for further information).

Setting the IDs of all the servo drives connected to a Decentral Access Module (DAM 510) or Power Supply Module (PSM 510) at the same time can also be done via the LCP when it is connected to the DAM 510/PSM 510.

6.4.3.1 Setting the Node IDs of all Servo Drives and System Modules on a Decentral Access Module (DAM 510)/Power Supply Module (PSM 510) Line

The automatic PSM 510/DAM 510 ID assignment is used for automatically setting the *Node IDs* on all servo drives and system modules for a specified PSM 510/DAM 510 line. This functionality is contained in parameter group **54- ** ID Assignment** in subgroup **54-0* Automatic**.

Procedure

1. Attach the LCP to the PSM 510/DAM 510 that is connected to the servo drives and system modules for which the *Node ID* should be changed.
2. Press *[Hand On]* for >1 s to make the LCP the controlling interface for the PSM 510/DAM 510.
3. Press *[Main Menu]* then scroll down to parameter group **12-** Ethernet** and press *[OK]*.
4. Scroll down to parameter group **12-6* Ethernet POWERLINK** and press *[OK]*.
5. Change the PSM 510/DAM 510 node ID to the desired value (1–239) by pressing *[OK]*.
6. Return to the *Main Menu* and select parameter group **54-** ID Assignment**.
7. Select parameter group **54-0* Automatic**.
8. PSM 510 only: In parameter **54-01 Epl id assignment line**, select either Ethernet port X1 or X2. The PSM 510 assigns IDs to the selected device via the selected port and the fieldbus network. On DAM 510 port, X2 is used automatically.
9. Select parameter **54-02 Epl ID assignment start id** then select a valid value (1–239). The value is assigned to the device at the specified position index. The PSM 510/DAM 510 connected to the LCP is at position 0 and the 1st reachable device on the selected port is position index 1 and so on.
10. Select parameter **54-03 Automatic Epl ID assignment start** and change the status from *[0] ready* to *[1] start*.
11. Press *[OK]* to confirm the selection then wait for the ID assignment procedure to complete.
12. Check that the ID assignment was completed successfully using parameters:
 - a. Parameter **54-04 Epl ID assignment state**
 - b. Parameter **54-05 Epl ID assignment error code**
 - c. Parameter **54-06 Epl ID assignment device count**
13. Carry out a power cycle to ensure that all ID changes are in effect and operational on the fieldbus.



If an error occurs during ID assignment, the detected error is shown on the LCP. The following errors may be reported:

- Invalid NMT state
- Invalid comment
- Invalid Ethernet port
- Invalid node ID
- ID assignment failed
- Duplicate MAC address

- Invalid SW version
- Incomplete assignment
- No device found
- Internal error

6.5 PROFINET® ID Assignment

Each PROFINET® device needs a device name and an IP address. The IP address and the device name are assigned by the I/O controller, when the connection to the I/O device is established.

The IP address and the device name can also be assigned using PRONETA, a free tool that supports in the analysis and configuration of PROFINET® networks.

6.6 Power-Up Time

The maximum power-up time for the system modules is 15 s. This means the time from supplying the system with auxiliary voltage to the module being initialized completely.

The power-up time stated is an indicative time. The exact status of the module can be seen via the statusword.

NOTICE

- Do not operate any of the system modules until they are all powered up correctly.
- If 2 PSM 510 modules are mounted in parallel, power up both PSM 510 modules simultaneously (within a maximum delay of 1 s).

6.7 System Module Charging Time

The charging time of the system is determined by the longest charging time of each individual system module.

The exact status of each module can be seen via the statusword.

NOTICE

- Do not operate any of the system modules or decentral drives until they are charged up completely. Wait until PSM 510, DAM 510, and ACM 510 are in state *Operation enabled*, before bringing the ISD 520/DSD 520 into state *Operation enabled*.

Table 27: DC link (UDC) Charging Time for PSM 510, DAM 510, and ACM 510

| Specification | Unit | PSM 510 | DAM 510 | ACM 510 |
|-------------------|------|---------|---------|---------|
| UDC charging time | s | 2.0 | 2.0 | 3.5 |

6.8 Switching on the ISD 520/DSD 520 System

Complete the cabling of the servo system before applying power to the ISD 520/DSD 520 servo drives. This cabling provides the supply voltage and the communication signals for the servo system. This is a basic requirement for operation of the ISD 520/DSD 520 servo drives.

The servo system can be switched on in 2 ways:

- If the Power Supply Module (PSM 510) is supplied with mains, STO, and U_{AUX} , communication to the PSM 510 internal controller is established and DC link and U_{AUX} are automatically passed on via the backlink to the DAM 510 and then passed on further to the connected servo drives.
- If the Power Supply Module (PSM 510) is only powered by U_{AUX} , then the PSM 510, DAM 510, and servo drive control units are running.

6.8.1 Procedure for Switching on the ISD 520/DSD 520 System

Procedure

1. Switch on U_{AUX} power to enable communication to the PSM 510, DAM 510, and ISD 520/DSD 520 servo drives to be established.
2. Switch on the mains.
3. Set the PSM 510 to state *Normal operation*.
4. Set the DAM 510 to state *Normal operation*.

Now the PSM 510, DAM 510, and the ISD 520/DSD 520 servo drives are ready for operation.

6.9 Libraries

The libraries provided for the ISD 520/DSD 520 servo system are:

- TwinCAT® V3
- Automation Studio™ environment (version 4.x, supported platform SG4) to easily integrate the functionality without the need for special motion run-time on the controller.
- TiA from V17

The provided function blocks conform to the PLCopen® standard. Knowledge of the underlying fieldbus communication and/or the CANopen® CiA DS 402 profile is not necessary.

The library contains:

- Function blocks for controlling and monitoring the ISD 520/DSD 520 servo drives and the system modules.
- Function blocks for all available motion commands of the ISD 520/DSD 520 servo drives.
- Function blocks for controlling and monitoring the PSM 510, DAM 510, and ACM 510.
- Function blocks and structures for creating *Basic CAM* profiles.
- Function blocks and structures for creating *Labeling CAM* profiles.

6.10 Programming with Automation Studio™

6.10.1 Requirements for Programming with Automation Studio™

The following files are required to integrate the ISD 520/DSD 520 servo drives, the PSM 510, and DAM 510 into an Automation Studio™ project:

- Package of libraries for the MSD 510 servo system: VLT_FlexMotion_Automation_Studio_Lib_Vx.y.z.zip
- XDD file (XML Device Description) for the ISD 520/DSD 520 servo drive: 0x0200008D_VLT_[ISD/DSD]_520_ddd_CTy.xdd
- XDD file (XML Device Description) for the Power Supply Module (PSM 510): 0x0200008D_PSM.xdd
- XDD file (XML Device Description) for the Decentral Access Module (DAM 510): 0x0200008D_DAM.xdd

6.10.2 Creating an Automation Studio™ Project

The procedures described in this chapter apply to Automation Studio™ Version V4.x unless otherwise specified.

Information on how to install Automation Studio™ can be found in detail in the Automation Studio™ help. Open the B&R Help Explorer and go to [Automation software → Software Installation → Automation Studio].

Information on how to create a project in Automation Studio™ can be found in detail in the Automation Studio™ help.

Creating a project:

Open the B&R Help Explorer and go to *Automation Software* → *Getting Started* → *Creating programs with Automation Studio* → *Example project for a target system with CompactFlash*.

6.10.3 Including the Servo Motion Libraries into an Automation Studio™ Project

1. In the *Logical View*, open the menu entry *File* → *Import...*
2. In the next window, select the *Danfoss_VLT_ServoMotion_V_x_y_z.zip* file (according to the location on the hard drive).
3. Click on *Open*.
4. Assign the libraries to the CPU in the next window.
5. Click on *Finish*. Now the libraries are integrated into the Automation Studio™ project.



Table 28: Servo Motion Libraries

| Library | Description |
|------------|---|
| DDS_Drive | <ul style="list-style-type: none"> • Contains program organization units (POUs) defined by PLCopen® (name starting with MC_) and POUs defined by Danfoss (name starting with DD_). The Danfoss POUs provide additional functionality for the axis. • It is possible to combine POUs defined by PLCopen® with POUs defined by Danfoss. • The names of the POUs that target the servo drive all end with _DDS. • When integrating the DDS_Drive package, some standard libraries are integrated automatically, unless they are already part of the project. |
| DDS_PSM | <ul style="list-style-type: none"> • Contains POUs defined by Danfoss (name starting with DD_) and provides the functionality for the Power Supply Module (PSM 510). • The names of the POUs that target the PSM 510 all end with _PSM. |
| DDS_DAM | <ul style="list-style-type: none"> • Contains POUs defined by Danfoss (name starting with DD_) and provides the functionality for the Decentral Access Module (DAM 510). • The names of the POUs that target the DAM 510 all end with _DAM. |
| DDS_ACM | <ul style="list-style-type: none"> • Contains POUs defined by Danfoss (name starting with DD_) and provides the functionality for the Auxiliary Capacitors Module (ACM 510). • The names of the POUs that target the ACM 510 all end with _ACM. |
| DDS_BasCam | <ul style="list-style-type: none"> • Contains POUs for the creation of basic CAMs. |
| DDS_LabCam | <ul style="list-style-type: none"> • Contains POUs for the creation of labeling CAMs. |
| DDS_Intern | <ul style="list-style-type: none"> • Contains POUs that are needed internally for the libraries. • Do not use these POUs in an application. |

NOTICE

- Do not remove these libraries otherwise the Danfoss servo motion libraries will not work.

6.10.4 Constants within the DDS_Drive Library

The constants are defined inside the DDS_Drive library (see [Table 29](#)).

Table 29: List of Constants

| Constant | Description |
|-------------------------|---|
| Danfoss_VLT_ServoMotion | <ul style="list-style-type: none"> Contains the version information of the library. |
| DDS_AxisErrorCodes | <ul style="list-style-type: none"> Constants for error codes of the axis. Error codes can be read using the function block <i>MC_ReadAxisError_DDS</i> and/or <i>DD_ReadAxisWarning_DDS</i>. |
| DDS_AxisTraceSignals | <ul style="list-style-type: none"> Constants for the trace signals of the axis. Intended to be used with the function block <i>DD_Trace_DDS</i>. |
| DDS_BasCam | <ul style="list-style-type: none"> Constants for the creation of basic CAMs. |
| DDS_CamParsingErrors | <ul style="list-style-type: none"> Constants for parsing problems of a CAM. Error reason is returned by function block <i>MC_CamTableSelect_DDS</i>. |
| DDS_FB_ErrorConstants | <ul style="list-style-type: none"> Constants for errors inside POU's. The reason is given in an output <i>ErrorInfo.ErrorID</i> that is available in all POU's. |
| DDS_Intern | <ul style="list-style-type: none"> Constants which are needed internally for the library. They are not intended to be used in an application. |
| DDS_LabCam | <ul style="list-style-type: none"> Constants for the creation of labeling CAMs. |
| DDS_SdoAbortCodes | <ul style="list-style-type: none"> Constants for errors concerning reading and writing of parameters. The reason is given in an output <i>AbortCode</i> that is available in several POU's. |
| PSM_ErrorCodes | <ul style="list-style-type: none"> Constants for error codes of the Power Supply Module (PSM 510). Error codes can be read using the function block <i>DD_ReadPsmError_PSM</i> and/or <i>DD_ReadPsmWarning_PSM</i>. |
| PSM_TraceSignals | <ul style="list-style-type: none"> Constants for the trace signals of the Power Supply Module (PSM 510). Intended to be used with the function block <i>DD_Trace_PSM</i>. |
| DAM_ErrorCodes | <ul style="list-style-type: none"> Constants for error codes of the Decentral Access Module (DAM 510). Error codes can be read using the function block <i>DD_ReadDamError_DAM</i> and/or <i>DD_ReadDamWarning_DAM</i>. |
| DAM_TraceSignals | <ul style="list-style-type: none"> Constants for the trace signals of the Decentral Access Module (DAM 510). Intended to be used with the function block <i>DD_Trace_DAM</i>. |
| ACM_ErrorCodes | <ul style="list-style-type: none"> Constants for error codes of the Auxiliary Capacitors Module (ACM 510). Error codes can be read using the function block <i>DD_ReadAcmError_ACM</i> and/or <i>DD_ReadAcmWarning_ACM</i>. |
| ACM_TraceSignals | <ul style="list-style-type: none"> Constants for the trace signals of the Auxiliary Capacitors Module (ACM 510). Intended to be used with the function block <i>DD_Trace_ACM</i>. |

6.10.5 Instantiating `AXIS_REF_DDS` in Automation Studio™

1. Create 1 instance of function block `AXIS_REF_DDS` (located in folder `DDS_Drive`) for every servo drive that has to be controlled or monitored.
2. To create a link to the physical servo drive, link each instance of `AXIS_REF_DDS` to 1 physical servo drive. This makes it the logical representation of 1 physical servo drive.
 - a. Open the *Logical View*.
 - b. Initialize each instance with its node number and the slot name it is connected to (for example, IF3).
 - c. Initialize each instance of a drive with its *DriveType*.

6.10.6 Instantiating PSM_REF in Automation Studio™

1. Create 1 instance of function block *PSM_REF* (located in folder *DDS_PSM*) for every Power Supply Module (PSM 510) that has to be controlled or monitored.
2. To create a link to the physical PSM 510, link each instance of *PSM_REF* to 1 physical PSM 510. This makes it the logical representation of 1 physical PSM 510.
 - a. Open the *Logical View*.
 - b. Initialize each instance with its node number and the slot name it is connected to (for example, IF3).

6.10.7 Instantiating DAM_REF in Automation Studio™

1. Create 1 instance of function block *DAM_REF* (located in folder *DDS_DAM*) for every Decentral Access Module (DAM 510) that has to be controlled or monitored.
2. To create a link to the physical DAM 510, link each instance of *DAM_REF* to 1 physical DAM 510. This makes it the logical representation of 1 physical PSM 510.
 - a. Open the *Logical View*.
 - b. Initialize each instance with its node number and the slot name it is connected to (for example, IF3).

6.10.8 Instantiating ACM_REF in Automation Studio™

1. Create 1 instance of function block *ACM_REF* (located in folder *ACM_PSM*) for every Auxiliary Capacitors Module (ACM 510) that has to be controlled or monitored.
2. To create a link to the physical ACM 510, link each instance of *ACM_REF* to 1 physical ACM 510. This makes it the logical representation of 1 physical PSM 510.
 - a. Open the *Logical View*.
 - b. Initialize each instance with its node number and the slot name it is connected to (for example, IF3).

6.10.9 Importing a Servo Drive into Automation Studio™

NOTICE

- For each physical servo drive, add 1 entry to the *Physical View* of Automation Studio™.

6.10.9.1 Version V4.x

1. Select the menu entry *Tools → Import Fieldbus Device...*
2. Select the XDD file (for example, *0x0200008D_VLT_ISD_520_XXX_CTIO.xdd*) from its location on the hard drive. The device is then known to Automation Studio™.
3. Now add the servo drive to the Ethernet POWERLINK® interface of the controller in the *Physical View*:
 - a. Select the menu entry *Open → System Designer* to show the *System Designer*.
 - b. To add a hardware module to the *Physical View* or *System Designer*, select the servo drive in the group POWERLINK in the *Hardware Catalog* toolbox.
 - c. Drag the selected module to the desired position to connect it to the selected hardware module, network interface, or slot.
 - d. To change the node number, right-click on the device and select *Node Number → Change Node Number*.

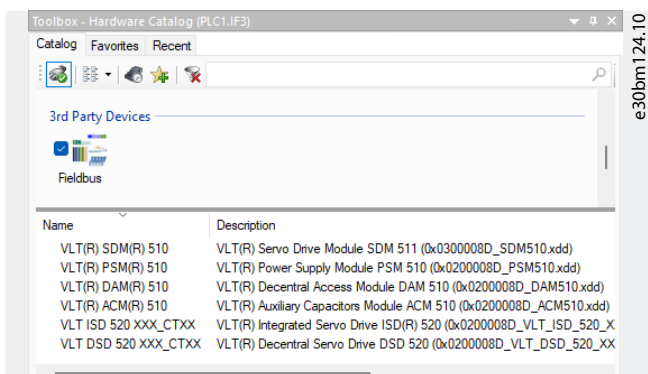

Figure 59: Adding a Servo Drive to the Project

6.10.10 Importing PSM 510, DAM 510, and ACM 510 into Automation Studio™

NOTICE

- For each physical Power Supply Module (PSM 510), Decentral Access Module (DAM 510), and Auxiliary Capacitors Module (ACM 510), add 1 entry to the Physical View of Automation Studio™.

6.10.10.1 Version V4.x

Procedure

1. Select the menu entry *Tools → Import Fieldbus Device...*
2. Select the XDD file for the PSM 510, DAM 510, or ACM 510 from its location on the hard drive. The device is then known to Automation Studio™.
 - Power Supply Module (PSM 510): 0x0200008D_PSM.xdd
 - Decentral Access Module (DAM 510): 0x0200008D_DAM.xdd
 - Auxiliary Capacitors Module (ACM 510): 0x0200008D_ACM.xdd
3. Now add the PSM 510, DAM 510, or ACM 510 to the Ethernet POWERLINK® interface of the controller in the *Physical View*:
 - a. Select the menu entry *Open → System Designer* to show the *System Designer*.
 - b. To add a hardware module to the *Physical View* or *System Designer*, select the PSM 510, DAM 510, or ACM 510 in the group *POWERLINK* in the *Hardware Catalog* toolbox.
 - c. Drag the selected module to the desired position to connect it to the selected hardware module, network interface, or slot.
 - d. To change the node number, right-click on the device and select *Node → Change Node Number*.

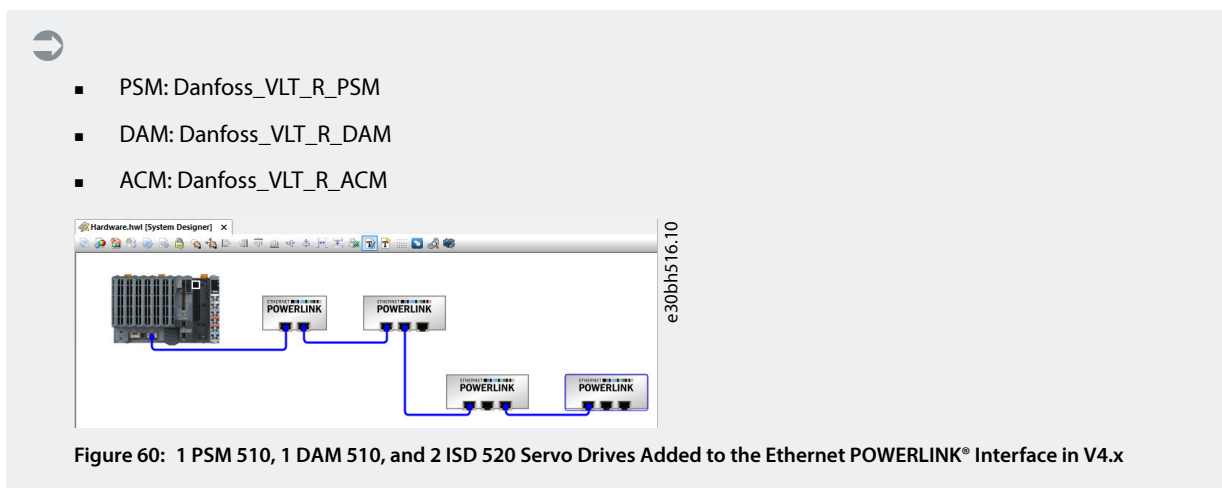

Figure 60: 1 PSM 510, 1 DAM 510, and 2 ISD 520 Servo Drives Added to the Ethernet POWERLINK® Interface in V4.x

6.10.11 I/O Configuration and I/O Mapping

Procedure

1. Parameterize the I/O configuration of the ISD 520/DSD 520 servo drives so that the library has access to all necessary objects.
 - a. Right-click on the entry of the ISD 520/DSD 520 servo drive and select *Configuration*.
 - b. In the *Channels* section, change the *Cyclic transmission* of the following objects:



- All sub-indexes of object 0x5050 (Lib pdo rx_I5050 ARRAY[]) to *Write*.
- All sub-indexes of object 0x5051 (Lib pdo tx_I5051 ARRAY[]) to *Read*.

2. Parameterize the I/O configuration of the Power Supply Module (PSM 510), Decentral Access Module (DAM 510), and Auxiliary Capacitors Module (ACM 510) so that the library has access to all necessary objects.
 - a. Right-click on the entry of the PSM 510/DAM 510/ACM 510 and select *Configuration*.
 - b. In the *Channels* section, change the *Cyclic transmission* of the following objects:



- All sub-indexes of object 0x5050 (Lib pdo rx_I5050 ARRAY[]) to *Write*.
- All sub-indexes of object 0x5051 (Lib pdo tx_I5051 ARRAY[]) to *Read*.

NOTICE

- These settings configure the cyclic communication with the device. These parameters are required for the library to work.
- It is possible to use copy and paste to apply the same I/O configuration to multiple devices of the same type.

3. Set *Module supervised* to *off* for the servo drives and the PSM 510/DAM 510/ACM 510. The parameter is found in the I/O configuration of the device.



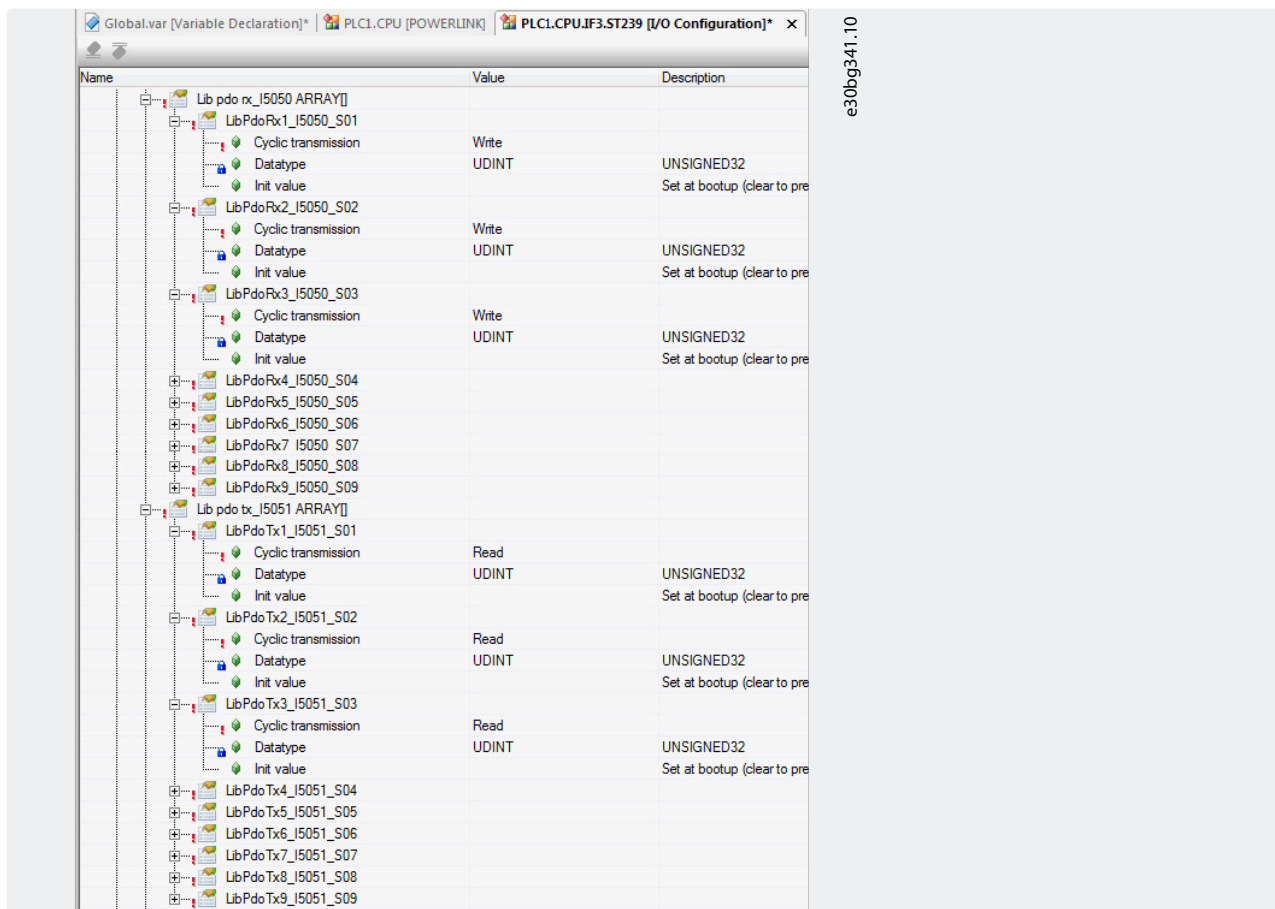

Figure 61: I/O Configuration of an ISD 520 Device

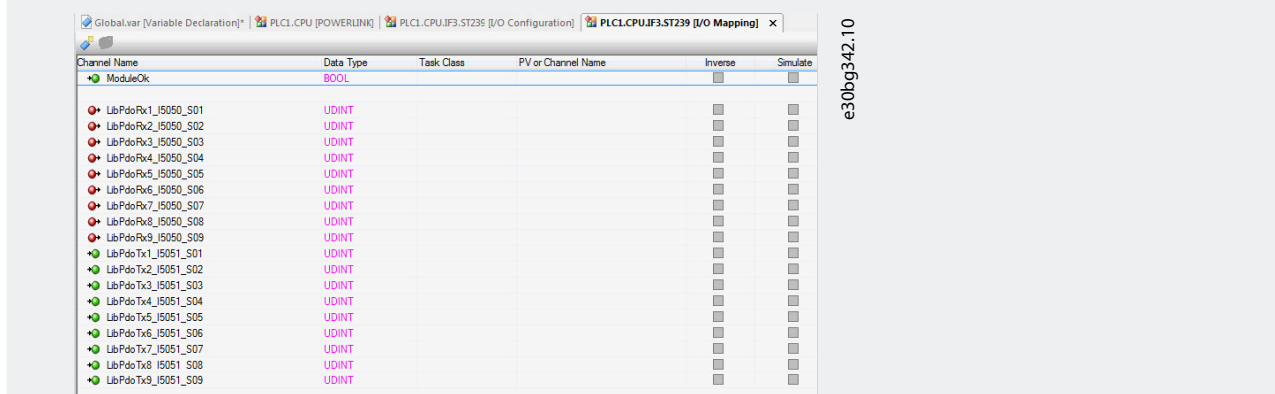
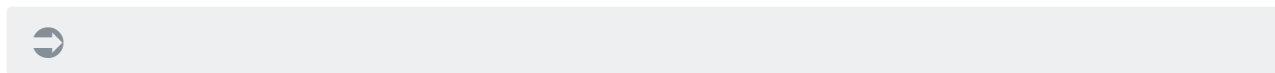

Figure 62: I/O Mapping after Successful Configuration

- Map the inputs and outputs of the instance of the `AXIS_REF_DDS` function block and the physical data points of the ISD 520/DSD 520 servo drive (here `myAxis` is an instance of `AXIS_REF_DDS`):



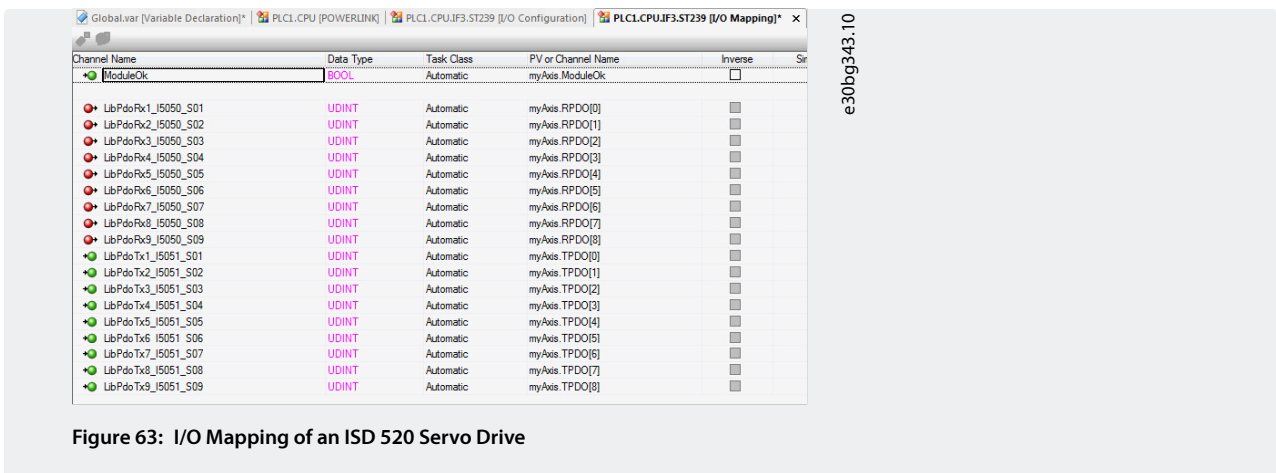

Figure 63: I/O Mapping of an ISD 520 Servo Drive

- Map the inputs and outputs of the instance of the *PSM_REF*, *DAM_REF*, and *ACM_REF* function blocks and the physical data points of the PSM 510/DAM 510/ACM 510 accordingly.

6.10.12 Setting the PLC Cycle Time

The minimum cycle time is 400 μ s. The servo system devices can run Ethernet POWERLINK[®] cycle times in multiples of 400 μ s and multiples of 500 μ s. The devices are automatically parameterized by the PLC on start-up, depending on the Ethernet POWERLINK[®] configuration of the physical interface.

The Ethernet POWERLINK[®] configuration can be accessed by right-clicking *PLK* → *Configuration* in the *Physical View*.

NOTICE

- Ensure that the task cycle times of the PLC program and Ethernet POWERLINK[®] are the same. Otherwise, data could be lost and performance reduced.

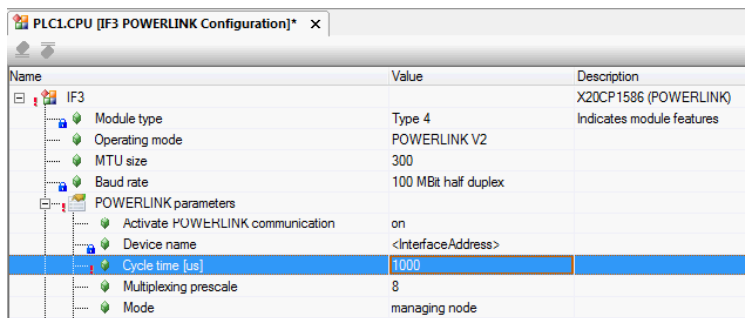

Figure 64: Ethernet POWERLINK[®] Configuration Window to Parameterize Ethernet POWERLINK[®] Cycle Time

Procedure

- Right-click *CPU* → *Configuration* → *Timing* in the *Physical View*.
- Ensure that the PLC cycle time is the same as the Ethernet POWERLINK[®] cycle time.

6.10.13 Connecting to the PLC

Information on how to connect to the PLC can be found in detail in the Automation Studio[™] Help.

Open the B&R Help Explorer and go to *Automation Software* → *Getting Started* → *Creating programs in Automation Studio* → *Example project for a target system with CompactFlash*.

6.11 Programming with TwinCAT®

6.11.1 Requirements for Programming with TwinCAT®

To integrate the ISD 520/DSD 520 servo drives and the PSM 510, DAM 510, or ACM 510 into a TwinCAT® project, the following files are required:

- Library for the ISD 520 servo system: Danfoss_VLT_ServoMotion_V_x_y_z.compiled-library
- Common ESI file (EtherCAT® Slave Information) Danfoss_Drives.xml with separate device sections for each configuration:
 - VLT® Integrated Servo Drive ISD 520
 - VLT® Integrated Servo Drive ISD 520 with VLT® FlexSafety™ option
 - VLT® Integrated Servo Drive ISD 520 with VLT® FlexSafety™ option and Safe I/O option board
 - VLT® Integrated Servo Drive ISD 520 with VLT® FlexSafety™ option and Standard I/O option board
 - VLT® Integrated Servo Drive ISD 520 with Standard I/O option board
 - VLT® Decentral Servo Drive DSD 520
 - VLT® Decentral Servo Drive DSD 520 with VLT® FlexSafety™ option
 - VLT® Decentral Servo Drive DSD 520 with VLT® FlexSafety™ option and Safe I/O option board
 - VLT® Decentral Servo Drive DSD 520 with VLT® FlexSafety™ option and Standard I/O option board
 - VLT® Decentral Servo Drive DSD 520 with Standard I/O option board
- ESI file (EtherCAT® Slave Information) for the Power Supply Module: Danfoss_PSM510.xml
- ESI file (EtherCAT® Slave Information) for the Decentral Access Module: Danfoss_DAM510.xml
- ESI file (EtherCAT® Slave Information) for the Auxiliary Capacitor Module: Danfoss_ACM510.xml

6.11.2 Creating a TwinCAT® Project

Information on how to install TwinCAT® can be found in detail in the Beckhoff Information System (<https://infosys.beckhoff.com/>).

Open the information system and select *TwinCAT 3 → Installation*.

Information on how to create a project in TwinCAT® can be found by opening the information system and selecting *TwinCAT 3 → TE1000 XAE → PLC*.

6.11.3 Including the TwinCAT® Library into a TwinCAT® Project

Before a library can be used in a project, it has to be first installed on the system via the *Library Repository*:

1. Right-click on the *References* in the PLC project tree and select *Library Repository*.
2. Click on *Install* and select the *Danfoss_VLT_ServoMotion_V_x_y_z* library file (according to the location on the hard drive). Now the library can be integrated into the TwinCAT project.
3. Close the *Library Repository* dialog by clicking on the *Close* button.
4. Right-click on the *References* in the PLC project tree and select *Add Library*.
5. Use the search field in the upper area of the *Add Library* dialog to filter available library references by name and select the *Danfoss_VLT_ServoMotion* library.
6. Click *OK* to complete the procedure and integrate the library reference into the TwinCAT® PLC project.

 Library references are also shown in the *Library Manager*, which offers a good overview of the installed PLC libraries and can be used to integrate and manage libraries in a project, similar to the procedure above.

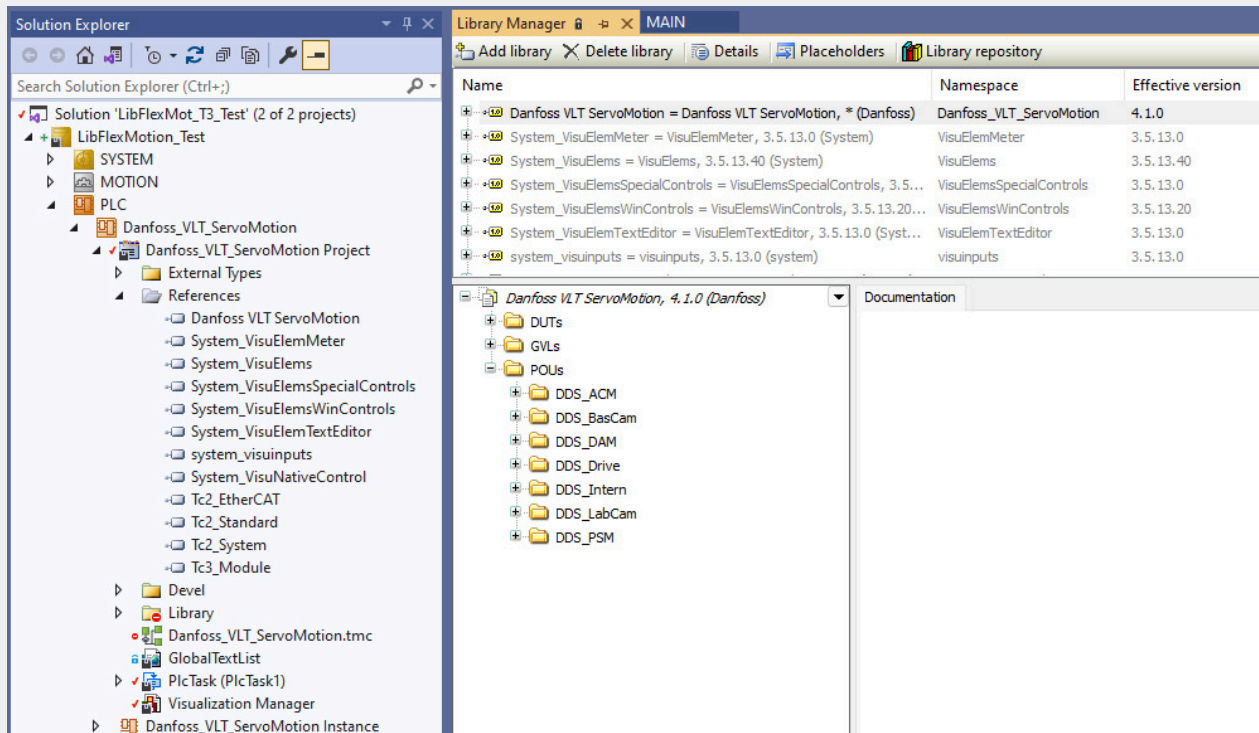

Figure 65: Library Manager after Including the ServoMotion Library

Inside the library, the POUs are organized into folders:

- DDS_Drive
 - Contains program organization units (POUs) defined by PLCopen® (name starting with MC_) and POUs defined by Danfoss (name starting with DD_). The Danfoss POUs provide additional functionality for the axis.
 - It is possible to combine POUs defined by PLCopen® with POUs defined by Danfoss.
 - The names of the POUs that target the servo drives all end with _DDS.
- DDS_PSM
 - Contains POUs defined by Danfoss (name starting with DD_) and provides the functionality for the Power Supply Module (PSM 510).
 - The names of the POUs that target the PSM 510 all end with _PSM.
- DDS_DAM
 - Contains POUs defined by Danfoss (name starting with DD_) and provides the functionality for the Decentral Access Module (DAM 510).
 - The names of the POUs that target the DAM 510 all end with _DAM.
- DDS_ACM
 - Contains POUs defined by Danfoss (name starting with DD_) and provides the functionality for the Auxiliary Capacitors Module (ACM 510).
 - The names of the POUs that target the ACM 510 all end with _ACM.
- DDS_BasCam
 - Contains POUs for the creation of basic CAMs.

- DDS_LabCam
 - Contains POU's for the creation of labeling CAMs.
- DDS_Intern
 - Contains POU's that are needed internally for the libraries.
 - Do not use these POU's in an application

When integrating the VLT® Integrated Servo Drive library, some standard libraries are integrated automatically, unless they are already part of the project.

NOTICE

- Do not remove these libraries otherwise the DDS libraries will not work.

6.11.4 Constants within the DDS_Drive Library

The constants are defined inside the DDS_Drive library (see [Table 30](#)).

Table 30: List of Constants

| Constant | Description |
|-------------------------|---|
| Danfoss_VLT_ServoMotion | <ul style="list-style-type: none"> • Contains the version information of the library. |
| DDS_AxisErrorCodes | <ul style="list-style-type: none"> • Constants for error codes of the axis. • Error codes can be read using the function block <i>MC_ReadAxisError_DDS</i> and/or <i>DD_ReadAxisWarning_DDS</i>. |
| DDS_AxisTraceSignals | <ul style="list-style-type: none"> • Constants for the trace signals of the axis. • Intended to be used with the function block <i>DD_Trace_DDS</i>. |
| DDS_BasCam | <ul style="list-style-type: none"> • Constants for the creation of basic CAMs. |
| DDS_CamParsingErrors | <ul style="list-style-type: none"> • Constants for parsing problems of a CAM. • Error reason is returned by function block <i>MC_CamTableSelect_DDS</i>. |
| DDS_FB_ErrorConstants | <ul style="list-style-type: none"> • Constants for errors inside POU's. • The reason is given in an output <i>ErrorInfo.ErrorID</i> that is available in all POU's. |
| DDS_Intern | <ul style="list-style-type: none"> • Constants which are needed internally for the library. • They are not intended to be used in an application. |
| DDS_LabCam | <ul style="list-style-type: none"> • Constants for the creation of labeling CAMs. |
| DDS_SdoAbortCodes | <ul style="list-style-type: none"> • Constants for errors concerning reading and writing of parameters. • The reason is given in an output <i>AbortCode</i> that is available in several POU's. |
| PSM_ErrorCodes | <ul style="list-style-type: none"> • Constants for error codes of the Power Supply Module (PSM 510). • Error codes can be read using the function block <i>DD_ReadPsmError_PSM</i> and/or <i>DD_ReadPsmWarning_PSM</i>. |
| PSM_TraceSignals | <ul style="list-style-type: none"> • Constants for the trace signals of the Power Supply Module (PSM 510). • Intended to be used with the function block <i>DD_Trace_PSM</i>. |
| DAM_ErrorCodes | <ul style="list-style-type: none"> • Constants for error codes of the Decentral Access Module (DAM 510). • Error codes can be read using the function block <i>DD_ReadDamError_DAM</i> and/or <i>DD_ReadDamWarning_DAM</i>. |
| DAM_TraceSignals | <ul style="list-style-type: none"> • Constants for the trace signals of the Decentral Access Module (DAM 510). • Intended to be used with the function block <i>DD_Trace_DAM</i>. |

Table 30: List of Constants - (continued)

| Constant | Description |
|------------------|---|
| ACM_ErrorCodes | <ul style="list-style-type: none"> Constants for error codes of the Auxiliary Capacitors Module (ACM 510). Error codes can be read using the function block <code>DD_ReadAcmError_ACM</code> and/or <code>DD_ReadAcmWarning_ACM</code>. |
| ACM_TraceSignals | <ul style="list-style-type: none"> Constants for the trace signals of the Auxiliary Capacitors Module (ACM 510). Intended to be used with the function block <code>DD_Trace_ACM</code>. |

6.11.5 Instantiating `AXIS_REF_DDS` in TwinCAT®

Procedure:

1. Create 1 instance of function block `AXIS_REF_DDS` (located in folder `DDS_Drive`) for the ISD 520 servo drive that has to be controlled or monitored.
2. Repeat step 1 for each additional servo drive.

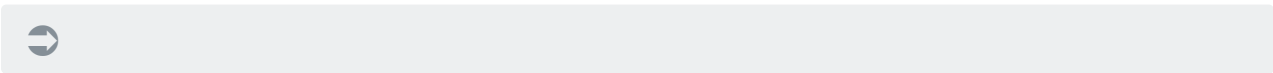

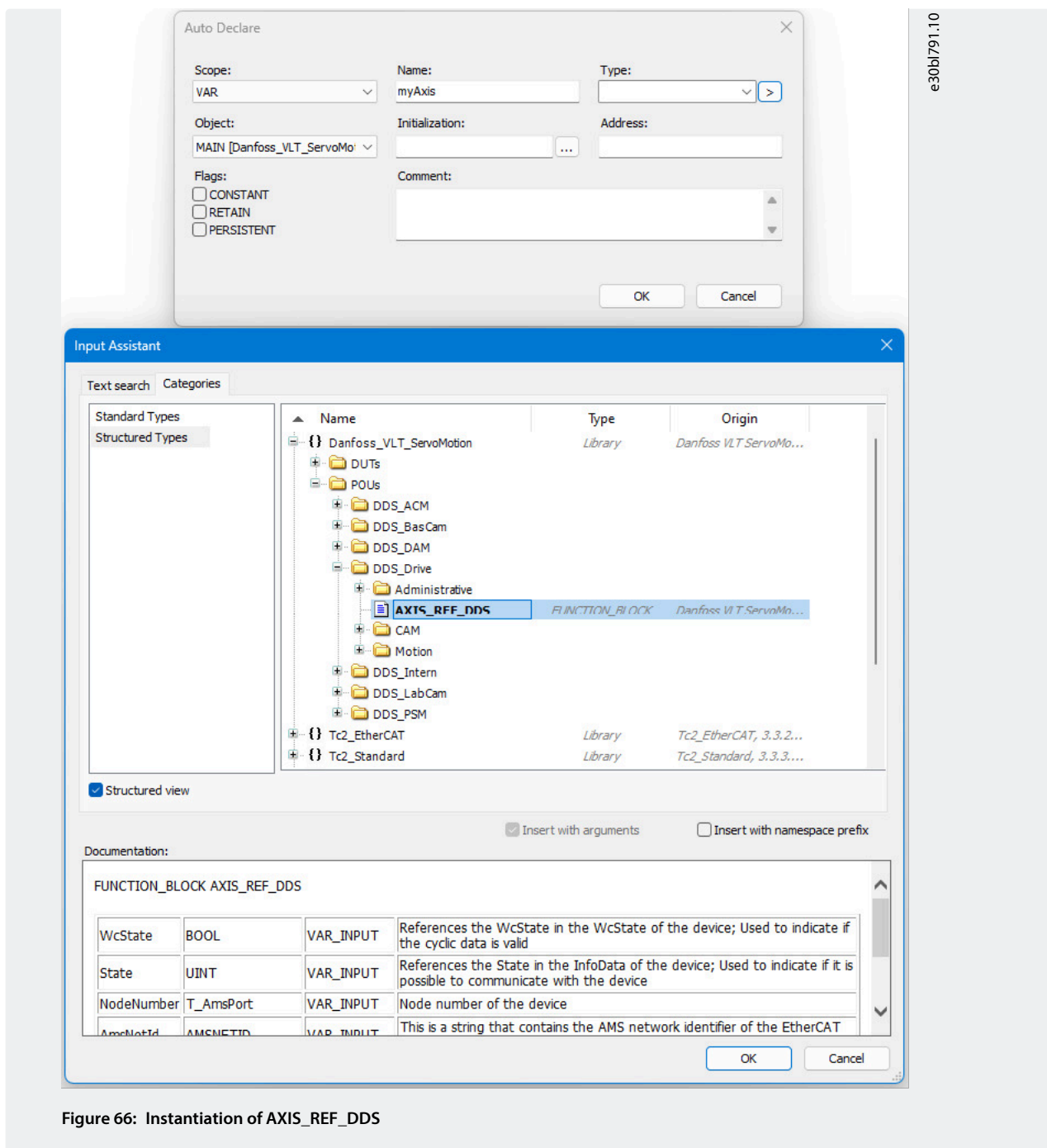

Figure 66: Instantiation of AXIS_REF_DDS

6.11.6 Instantiating PSM_REF in TwinCAT

Procedure:

1. Create 1 instance of function block *PSM_REF* (located in folder *DDS_PSM*) for each Power Supply Module that has to be controlled or monitored.
2. Repeat step 1 for each additional PSM 510.

6.11.7 Instantiating DAM_REF in TwinCAT

1. Create 1 instance of function block *DAM_REF* (located in folder *DDS_PSM*) for each Decentral Access Module that has to be controlled or monitored.
2. Repeat step 1 for each additional DAM 510.

6.11.8 Instantiating ACM_REF in TwinCAT

Procedure:

1. Create 1 instance of function block *ACM_REF* (located in folder *DDS_ACM*) for each Auxiliary Capacitors Module that has to be controlled or monitored.
2. Repeat step 1 for each additional ACM 510.

6.11.9 Adding a PLC Project to TwinCAT® System Manager

A PLC project contains the objects required to create a controller program:

- Pure programming blocks, for example, programs, function blocks, functions, GVLs.
- Objects that are also required to run the program on a PLC, for example, referenced tasks, library managers, and visualizations.

A standard PLC project can be created as follows:

1. Select the command *New* → *Project* in the menu *File*.
2. Select the template *TwinCAT Projects* → *TwinCAT XAE Project*, then enter a name (for example, *TwinCAT project*) and a storage location in the file system. Click on *OK* to confirm.
3. A new solution opens in the Solution Explorer with an empty PLC project.
4. Mark the *PLC* object in the project tree and select the command *Add New Item* in the menu *Projector* in the context menu. The dialog *Add New Item <TwinCAT project name>* opens.
5. Select the *Standard PLC Project* in the category *Plc Templates* and enter a name (for example, *PLC project*).
6. Quit the dialog with *Add*. The following structure is created in the view *Solution Explorer*.

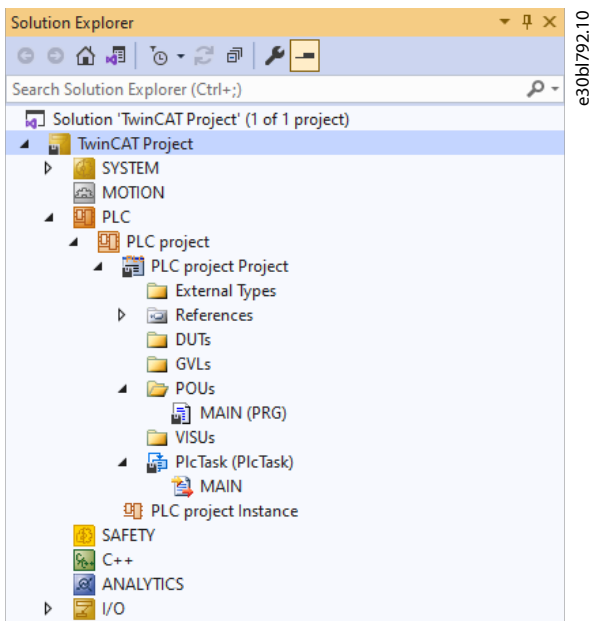

Figure 67: Structure of a Standard PLC Project

With the selected template the following basic objects appear automatically under the node *PLC Project*:

- A PLC project (*PLC project Project*) and a project instance (*PLC project Instance*).
- The PLC project contains:
 - A library manager (*References*).
 - The standard program block *MAIN* and a task reference (*PlcTask*). The task referenced there (*PlcTask*) defines the execution of the program block *MAIN*.
 - In addition, the structure folders *External Types*, *DUTs*, *GVLs*, *POUs*, and *VISUs* appear automatically.

The library manager already contains the standard libraries with basic blocks such as counters, timers, and string functions that can then be used for programming.

Filling *MAIN* with error-free code enables it to be loaded to the controller and run without the need for further programming objects.

6.11.10 Importing Devices to TwinCAT®

The TwinCAT® System Manager and the TwinCAT® EtherCAT Master require the device description files of all EtherCAT devices for configuration in online and offline mode.

The device descriptions are contained in the so-called ESI files (EtherCAT Slave Information) in XML format, and they should be made available to TwinCAT® before a device can be imported into the project. Only then can new I/O modules be imported into the TwinCAT® project.

The whole procedure can be summarized as follows.

1. Copy the *Danfoss_Drives.xml* ESI file into TwinCAT® installation directory *C:\TwinCAT\3.1\Config\Io\EtherCAT* on the hard drive*.
2. Right-click on *I/O* → *Devices* and select *Add New Item*.
3. In the following window, select *EtherCAT* → *EtherCAT Master* and click on *OK*.

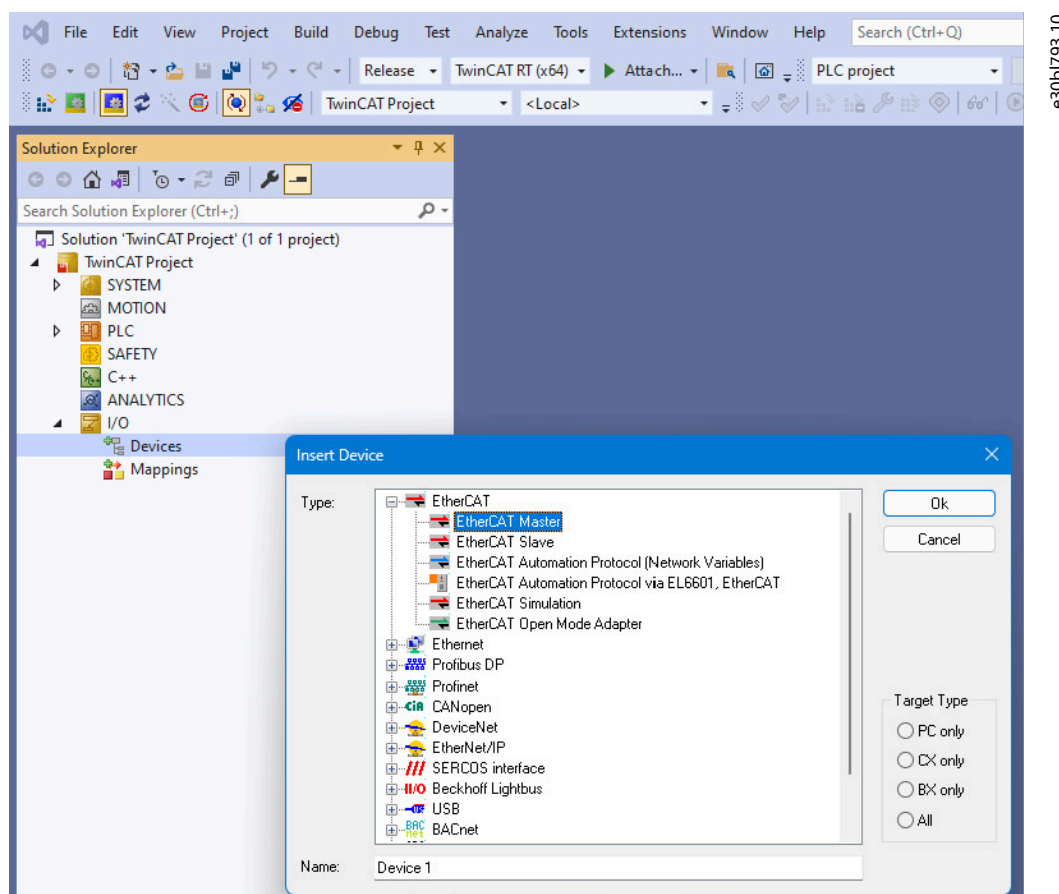

Figure 68: Add an EtherCAT Master to the Project

4. A new entry *Device 1* is now available in the tree view of the I/O configuration, with its own input and output modules (boxes) added below the device's node. Before it can be used, the correct network adapter should be selected in the *Device Found At* window.
5. Right-click on the configured I/O device *Device1 (EtherCAT)* to open the context menu for adding 1 of the supported I/O modules. Select menu item *Add New Item* to open the *Insert EtherCAT Device* window and select from the available modules.

- To add a VLT® Power Supply Module, select *Danfoss GmbH* → *VLT® FlexMotion* → *VLT® Power Supply Module PSM 510* and click on *OK* to confirm I/O device selection and close the window.

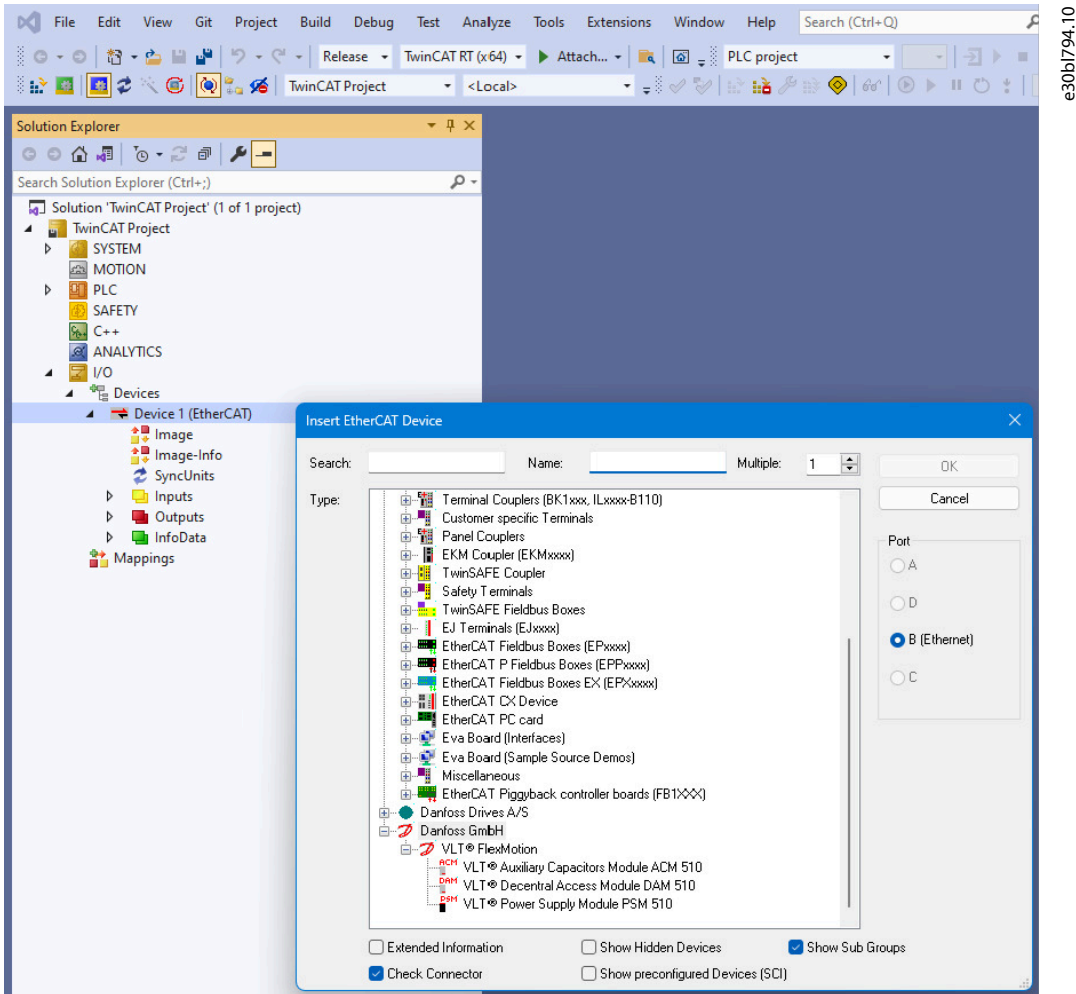

Figure 69: Add a VLT® Power Supply Module PSM 510 to the Project

- To add a VLT® Decentral Access Module, right-click on *Device1 (EtherCAT)* and select *Add New Item*.
- In the *Insert EtherCAT Device* window, select *Danfoss GmbH* → *VLT® FlexMotion* → *VLT® Decentral Access Module DAM 510* and click on *OK* to confirm I/O device selection and close the window.
- To add a VLT® Auxiliary Capacitors Module ACM 510, right-click on *Device1 (EtherCAT)* and select *Add New Item*.
- In the *Insert EtherCAT Device* window, select *Danfoss GmbH* → *VLT® FlexMotion* → *VLT® Auxiliary Capacitors Module ACM 510* and click on *OK* to confirm I/O device selection and close the window.
- To add a VLT® Servo Drive Module to the VLT® Decentral Access Module DAM 510, right-click on *Box 1 (VLT® Decentral Access Module 510)* and select *Add New Item*.
- In the *Add EtherCAT Device* window, select *Danfoss Drives A/S* → *VLT® FlexMotion* → *VLT® Integrated Servo Drive ISD® 520* and click on *OK* to confirm I/O device selection and close the window.

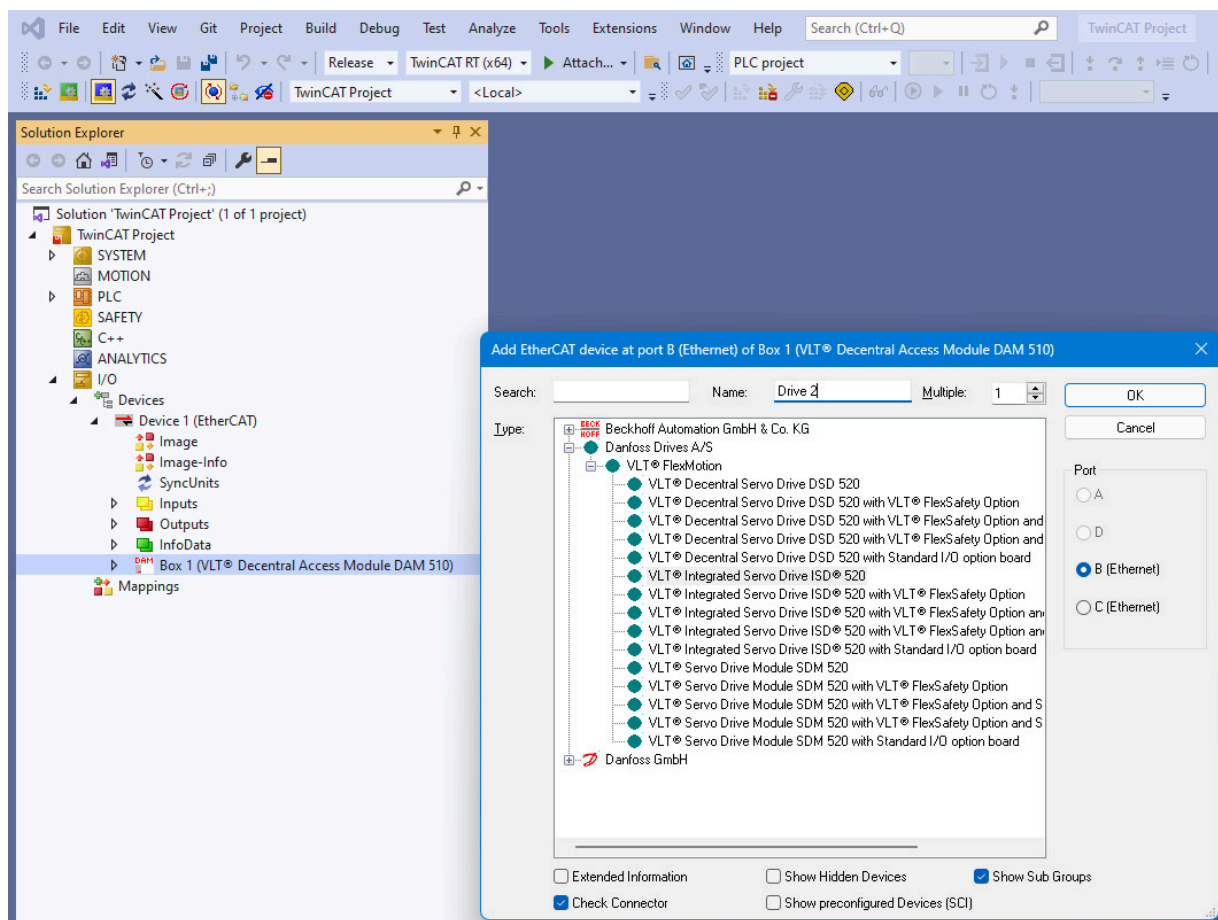

Figure 70: Add a VLT® Integrated Servo Drive ISD® 520 to the Project

13. Answer the question if the servo drive is used as an NC axis with *Cancel*. If the servo drive is to be used as an NC axis, see [6.11.14 Configuration as a TwinCAT® NC Axis](#).

➡ This is the result after appending a new PLC Project and adding some Danfoss devices:

- 1 x VLT® Decentral Access Module DAM 510
- 2 x VLT® Integrated Servo Drive ISD® 520

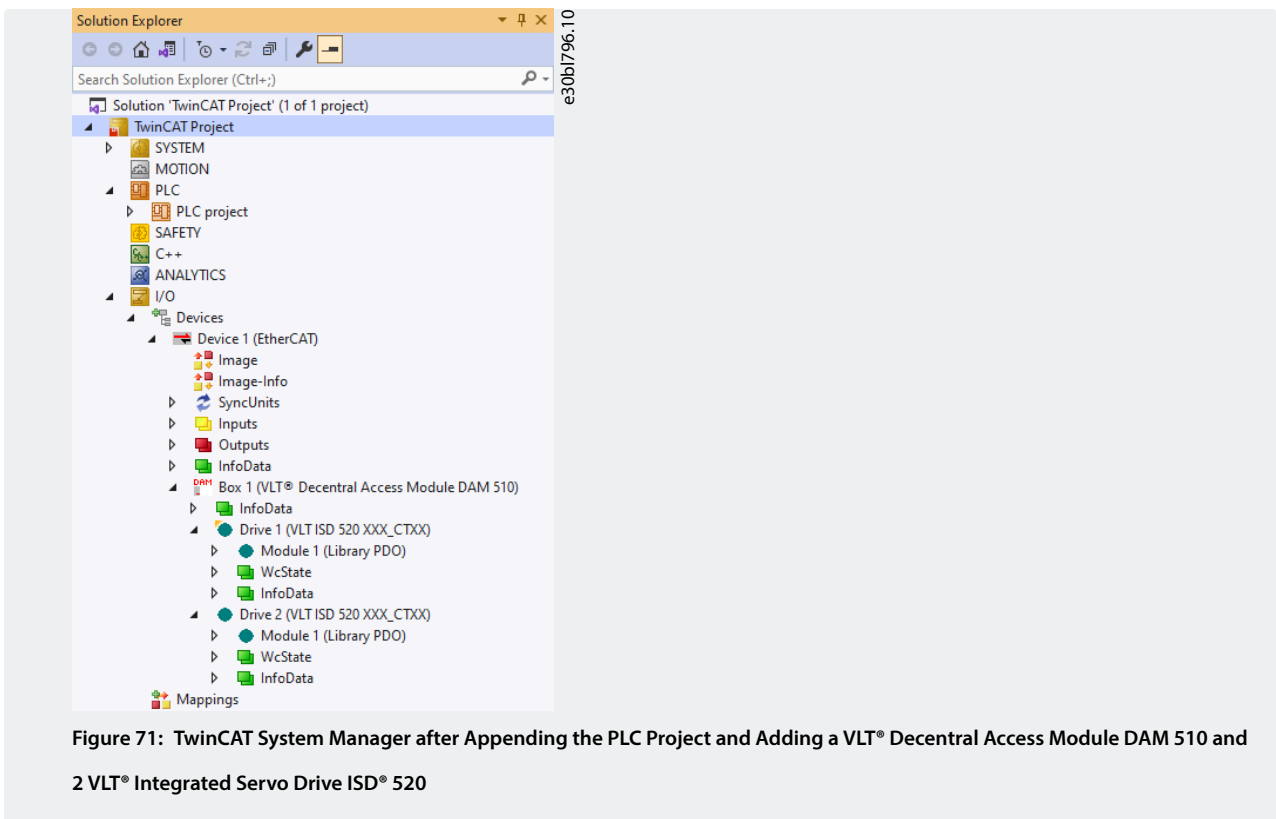

Figure 71: TwinCAT System Manager after Appending the PLC Project and Adding a VLT® Decentral Access Module DAM 510 and 2 VLT® Integrated Servo Drive ISD® 520

NOTICE

- Add 1 entry to the EtherCAT® master of the TwinCAT System Manager for each physical servo drive, PSM 510, DAM 510, and ACM 510. Add the servo drive to the correct DAM 510 line.

This step only has to be done once per project because the TwinCAT® System Manager automatically searches for ESI files at this location on the hard drive during start-up.

6.11.11 I/O Configuration and I/O Mapping

For each EtherCAT device, the TwinCAT® System Manager indicates at which *Previous Port* it is connected, that is, the name of the connected port (B to D) of the previous slave. This assignment is required to correctly map an EtherCAT network in TwinCAT® "offline" configuration.

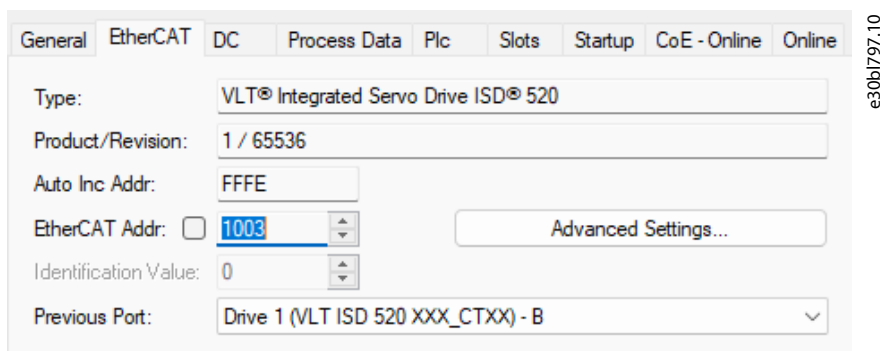

Figure 72: Setting the Previous Port of an EtherCAT Device

When connecting >1 ISD 520/DSD 520 servo drive, ensure that port B of the previous servo drive is connected to port C of the next servo drive. Port assignment is also required for VLT® Decentral Access Modules.

If the hardware setup is already present, the *Scan* command of the TwinCAT® System Manager can be used to automatically add the connected devices to the configuration in the correct order.

It is also important that the ISD 520/DSD 520 servo drive configuration is optimized so that the process data output (PDO) mapping matches the requirements of the library.

1. Click on the VLT® ISD 520 drive entry to show the general and terminal-specific dialogs.
2. Select the *Slots* tab on the right side of the window.
3. Make sure that *Library PDO* is selected as the PDO mapping module in the *Slot* box. If not, replace the current module (for example, *CSP PDO configuration*) with *Library PDO* using the available buttons.

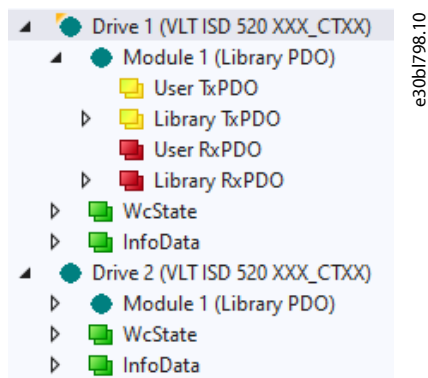

Figure 73: ISD 520 Servo Drive with Correct I/O Configuration

6.11.12 Attaching the Input and Output Variables to the Physical Data Points

Use the TwinCAT® System Manager to attach the input and output variables of the PLC program to the physical inputs and outputs of the device. This ensures that the library has access to all necessary objects.

WARNING

- Repeat steps 2–22 for Box 1 (VLT® Power Supply Module) and the instance *myPSM*.
- Repeat steps 2–22 for Box 2 (VLT® Decentral Access Module) and the instance *myDAM*.

1. In the tree view of the I/O configuration, select *Library TxPDO* via menu *I/O* → *Devices* → *Device 1 (EtherCAT)* → *Box 1 (VLT® Decentral Access Module DAM 510)* → *Drive 1 (VLT ISD 520 XXX_CTXX)* → *Module 1 (Library PDO)* → *Library TxPDO*.
2. Select entries from *Lib pdo tx 1* to *Lib pdo tx 9* that form the transmit PDO (TxPDO).
3. Right-click and select *Change Multi Link*.
4. In the *Attach Variable 36.0 Byte(s) (Input)* window, select the variable referencing the servo drive *MAIN*. → *myAxis1*. → *TPDO*. Ensure that the *Matching Size* option is selected in the *Attach Variable* window.

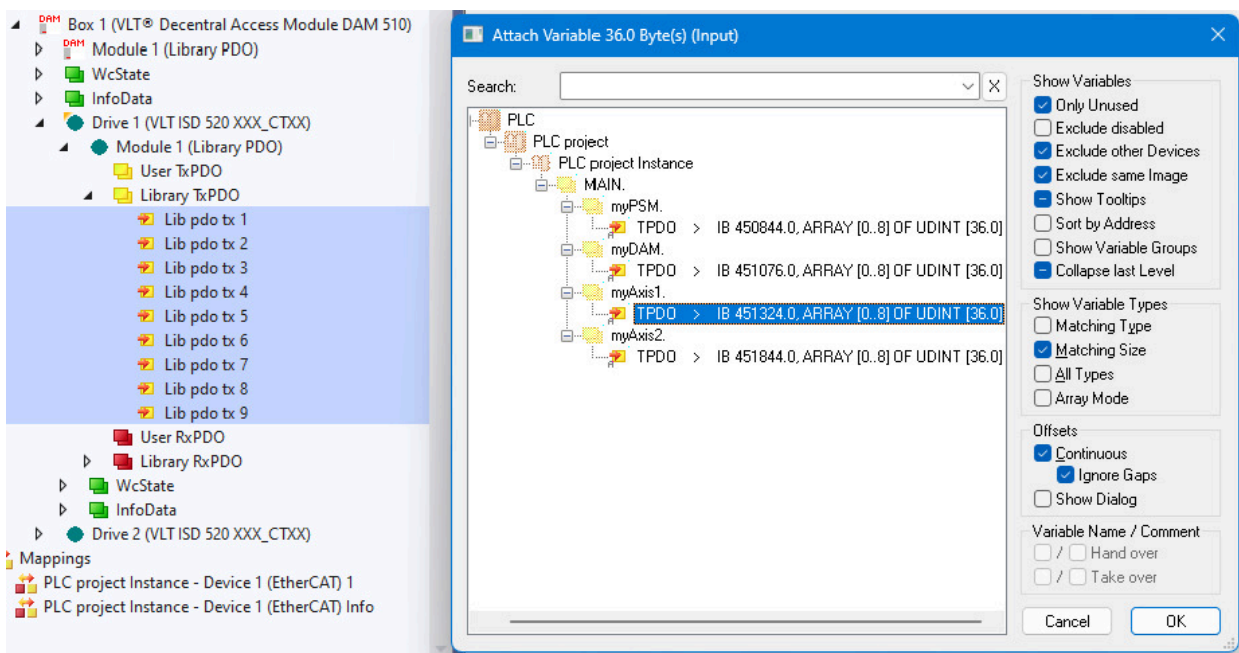

e30b1799.10

Figure 74: Attaching Inputs and Outputs to the Physical Data Points

5. Click on OK.
6. In the tree view of the I/O configuration, select *Library RxPDO* via menu *I/O → Devices → Device 1 (EtherCAT) → Box 1 (VLT® Decentral Access Module DAM 510) → Drive 1 (VLT ISD 520 XXX_CTXTX) → Module 1 (Library PDO) → Library RxPDO*.
7. Select all entries from *Lib pdo rx 1* to *Lib pdo rx 9* that form the receive PDO (RxPDO).
8. Right-click and select *Change Multi Link*.
9. In the *Attach Variable 36.0 Byte(s) (Output)* window, select the variable referencing the servo drive MAIN. → *myAxis1*. → *RPDO*. Ensure that the *Matching Size* option is selected in the *Attach Variable* window.
10. Click on OK.
11. Right-click on the *WcState* item *I/O → Devices → Device 1 (EtherCAT) → Box 1 (VLT® Decentral Access Module DAM 510) → Drive 1 (VLT ISD 520 XXX_CTXTX) → WcState → WcState* and select *Change Link*.
12. In the *Attach Variable State (Input)* window, select MAIN. → *myAxis1*. → *WcState*.
13. Click on OK.
14. Right-click on the *State* item *I/O → Devices → Device 1 (EtherCAT) → Box 1 (VLT® Decentral Access Module DAM 510) → Drive 1 (VLT ISD 520 XXX_CTXTX) → InfoData → State* and select *Change Link*.
15. In the *Attach Variable State (Input)* window, select MAIN. → *myAxis1*. → *State*.
16. Click on OK.
17. Right-click on the *netId* item *I/O → Devices → Device 1 (EtherCAT) → Box 1 (VLT® Decentral Access Module DAM 510) → Drive 1 (VLT ISD 520 XXX_CTXTX) → InfoData → AdsAddr → netId* and select *Change Link*.
18. In the *Attach Variable netId (Input)* window, select MAIN. → *myAxis1*. → *AmsNetId*.
19. Click on OK.
20. Right-click on the *port* item *I/O → Devices → Device 1 (EtherCAT) → Box 1 (VLT® Decentral Access Module DAM 510) → Drive 1 (VLT ISD 520 XXX_CTXTX) → InfoData → AdsAddr → port* and select *Change Link*.
21. In the *Attach Variable port (Input)* window, select MAIN. → *myAxis1*. → *NodeNumber*.
22. Click on OK.

6.11.13 Configuring the Real-Time

The runtime component of TwinCAT 3 (XAR) has to run under real-time conditions so that it will not be pre-empted by other tasks on the computer while executing machine control logic. The tasks it executes always get priority over normal Windows programs.

To configure the real-time behavior of TwinCAT 3, follow these steps:

1. Double-click on the *SYSTEM* → *Real-Time node* in the *Solution Explorer* to open the Real-Time configuration window.
2. Click the *Read from Target* button to make TwinCAT 3 read the actual configuration from the PC. The cores are listed in the top list box and they can be allocated between Windows (like *Shared Cores 0–2* with *RT-Core* option unchecked), the TwinCAT 3 runtime (like *Isolated Cores 4–7* with *RT-Core* option checked), or both (like *Shared Core 3*, with *RT-Core* option checked). The *Core Limit* column shows how much CPU time is reserved to the TwinCAT 3 runtime when it shares a core with Windows.

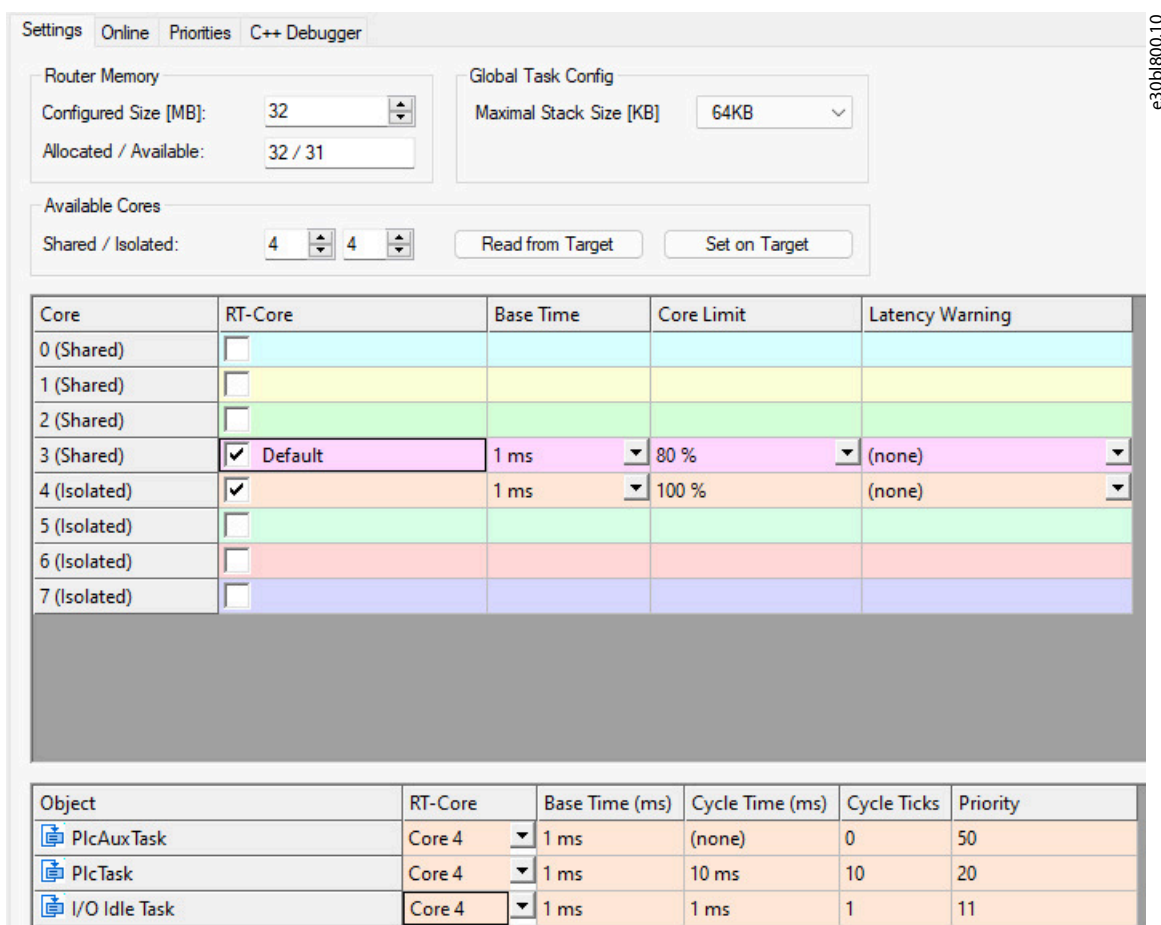

Figure 75: Real-Time Configuration

3. The lower grid allows to configure which tasks run on which core. It also shows the EtherCAT cycle time under the column *Base Time (ms)* as well as the cycle time of the task running the PLC program (*PlcTask*) under column *Cycle Time (ms)*. For optimum performance, it is essential that these 2 values are equal otherwise data may be lost and performance reduced. The *Base Time* can be set under the corresponding column in the upper grid, while the *Cycle Time* can be indirectly changed via the *Tasks* node in the *Solution Explorer* (*System* → *Tasks* → *PlcTask*), where the number of cycle ticks used by a certain task is defined:

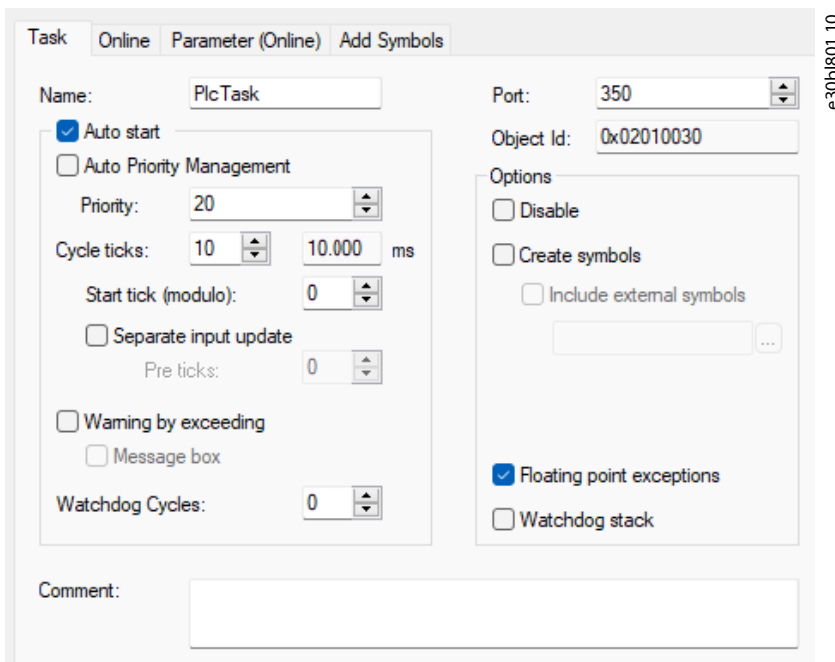

Figure 76: Task Configuration

4. ISD 520 devices can only run EtherCAT® cycle times in multiples of 400 µs or 500 µs, therefore ensure that a multiple of these base times is chosen for proper functionality.

NOTICE

- Set the task cycle time of the PLC program to be the same as the EtherCAT® cycle time. Otherwise data may be lost and performance reduced.

NOTICE

- Connect the PSM 510, DAM 510, and ACM 510 to 1 SYNC unit and the ISD 520/DSD 520 servo drives to another. This protects against interruptions in communication to the PSM 510 and DAM 510 if the U_{AUX} supply to the servo drives is switched off due to an error.

6.11.14 Configuration as a TwinCAT® NC Axis

The servo drives can be used with the built-in NC functionality of TwinCAT®.

Everything that is related to the PSM 510 and DAM 510 must be done as described in [6.11.2 Creating a TwinCAT® Project](#).

1. In addition to the *Danfoss_VLT_ServoMotion_V_x_y_z.lib* file, include the *Tc2_MC2* library.
2. Create 1 instance of *AXIS_REF* (instead of *AXIS_REF_DDS*) for each ISD 520/DSD 520 servo drive that is used as an NC axis.
3. Append the PLC project into the TwinCAT® System Manager, import the devices, and add them to TwinCAT®, however in the last step, answer the question if the servo drive is used as an NC axis with Yes. Then an NC task is created automatically.

6.11.14.1 I/O Configuration for Servo Drives used as NC Axes

In the TwinCAT® System Manager, select a different I/O Configuration for the servo drives used as NC axes.

1. Depending on the mode of operation to be used, select either the slot *CSP PDO* or *CSV PDO* (see [6.11.11 I/O Configuration and I/O Mapping](#) for process data output (PDO) mapping details). Per default, *CSV PDO* is mapped and pre-selected.
2. Map the following variables if the VLT® Integrated Servo Drive servo drive is required to work with *CSP PDO*:
 - a. In the *Settings* Tab of the NC Axis, select *MOTION* → *NC-Task 1 SAF* → *Axes* → *Axis 1*. Click on the *Link To I/O* button and select the servo drive under I/O to be linked with the NC axis.

- b. Click on the *Link To PLC* button and select the PLC instance of the axis to be linked with the NC axis.
3. In the same tab, select the preferred *Unit* for the position of the axis.
4. Depending on the selected unit, adjust the Scaling Factor for the axis encoder via menu *MOTION* → *NC-Task 1 SAF* → *Axes* → *Axis 1* → *Enc* in the *Parameter* tab.

When the unit *Degrees* is selected, the scaling factor is $360^\circ/2^{20} = 0.00034332275390625$.

5. Set the *Reference Velocity* in the *Parameter* tab via menu *MOTION* → *NC-Task 1 SAF* → *Axes* → *Axis 1*.
6. Set the *Output Scaling Factor (Velocity)* to 125.
7. Test the functionality and the configuration in the *Online* tab of the axis.

6.11.15 Loading the Program Code and Starting the PLC

Information on how to transfer the PLC project to the controller can be found in the Back-end Information System.

Open the information system and go to *TwinCAT 3* → *TE1000 XAE* → *PLC* → *Transfer PLC project to the PLC*.

6.12 Programming Guidelines for Automation Studio[™] and TwinCAT[®]

Recommendations for implementation:

- Initialize parameters that usually do not change only once at the beginning of the program. In Automation Studio[™], use the *_INIT* section.
- Call up function blocks that provide status or error information with *Enable input* at the beginning of the program.
- Use 1 instance of the function block *MC_Power_DDS* for every axis to control its power stage. Call up this function block in every PLC cycle.
- Use 1 instance of the function block *DD_Power_PSM* for every PSM 510 to control the DC-link voltage on the output. Call up this function block in every PLC cycle.
- Use 1 instance of the function block *DD_Power_DAM* for every DAM 510 to control the DC-link voltage on the output. Call up this function block in every PLC cycle.
- Use 1 instance of the function block *DD_Power_ACM* for every ACM 510 to control the connection between the DC link and the ACM 510. Call up this function block in every PLC cycle.
- Call up function blocks that execute (motion) commands at the end of the program.
- Do not use any POU's from the library (folder) *DDS_Intern*.
- Do not change the reference to the axis on a function block while it is busy.

6.13 Programming with TIA

6.13.1 Requirements for Programming with TIA

The following files are required to integrate the servo system modules into a TIA project. In the filename, 2.xx represents the version number and *yyyymmdd* represents the date.

Table 31: Required Files

| System module | File required |
|-------------------------------------|---|
| Whole servo system | Package of libraries for the ISD 520/DSD 520 servo system: <i>Danfoss_VLT_ServoMotion_V_x_y_z.zalxx</i> . |
| ISD 520/DSD 520 servo drive | Common GSDML file (General station description) <i>GSDML-V2.xx-Danfoss-DDS-yyyyymmdd.xml</i> with separate device access points for the following configurations: <ul style="list-style-type: none"> • VLT® Decentral Servo Drive DSD 520 • VLT® Decentral Servo Drive DSD 520 with VLT® FlexSafety™ option • VLT® Decentral Servo Drive DSD 520 with VLT® FlexSafety™ option and Safe I/O option board • VLT® Decentral Servo Drive DSD 520 with VLT® FlexSafety™ option and Standard I/O option board • VLT® Decentral Servo Drive DSD 520 with Standard I/O option board • VLT® Integrated Servo Drive ISD 520 • VLT® Integrated Servo Drive ISD 520 with VLT® FlexSafety™ option • VLT® Integrated Servo Drive ISD 520 with VLT® FlexSafety™ option and Safe I/O option board • VLT® Integrated Servo Drive ISD 520 with VLT® FlexSafety™ option and Standard I/O option board • VLT® Integrated Servo Drive ISD 520 with Standard I/O option board |
| Power Supply Module PSM 510 | GSDML file (General station description): <ul style="list-style-type: none"> • <i>GSDML-V2.xx-Danfoss-PSM-yyyyymmdd.xml</i> |
| Decentral Access Module DAM 510 | GSDML file (General station description): <ul style="list-style-type: none"> • <i>GSDML-V2.xx-Danfoss-DAM-2Port-IRT-yyyyymmdd.xml</i> • <i>GSDML-V2.xx-Danfoss-DAM-3Port-RT-yyyyymmdd.xml</i> |
| Auxiliary Capacitors Module ACM 510 | GSDML file (General station description): <ul style="list-style-type: none"> • <i>GSDML-V2.xx-Danfoss-ACM-yyyyymmdd.xml</i> |

6.13.2 Creating a TIA Project

NOTICE

- TIA V17 or higher must be installed to create a project.

6.13.3 Including the Servo Motion Libraries into a TIA Project

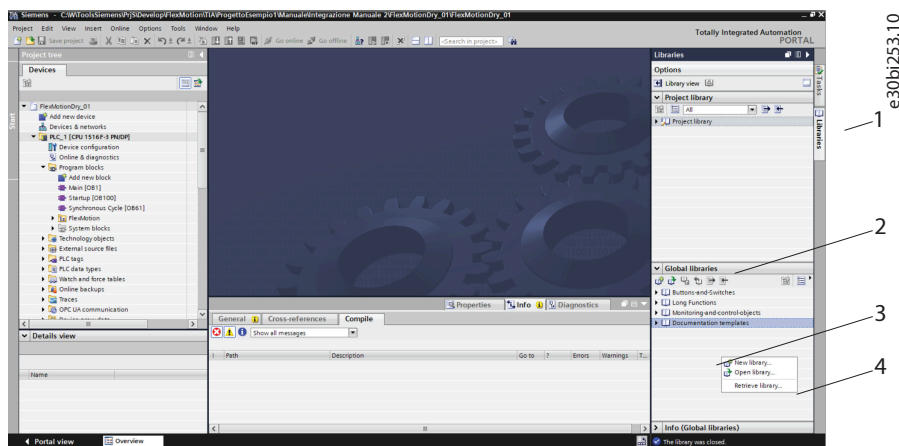

Figure 77: Including the Servo Motion Libraries

1. Expand the *Libraries* window [1], then select and expand the *Global libraries* section [2].
2. Right-click on the empty area [3] then select menu entry *Retrieve library...* [4].
3. Select the *Danfoss_VLT_ServoMotion_V_x_y_z.zal1x* file (according to the location on the hard drive).



Table 32: Servo Motion Libraries

| Library | Description |
|------------|---|
| DDS_Drive | <ul style="list-style-type: none"> • Contains program organization units (POUs) defined by PLCopen® (name starting with MC_) and POUs defined by Danfoss (name starting with DD_). The Danfoss POUs provide additional functionality for the axis. • It is possible to combine POUs defined by PLCopen® with POUs defined by Danfoss. • The names of the POUs that target the servo drive all end with _DDS. • When integrating the DDS_Drive package, some standard libraries are integrated automatically, unless they are already part of the project. |
| DDS_PSM | <ul style="list-style-type: none"> • Contains POUs defined by Danfoss (name starting with DD_) and provide the functionality for the Power Supply Module (PSM 510). • The names of the POUs that target the PSM 510 all end with _PSM. |
| DDS_DAM | <ul style="list-style-type: none"> • Contains POUs defined by Danfoss (name starting with DD_) and provide the functionality for the Decentral Access Module (DAM 510). • The names of the POUs that target the DAM 510 all end with _DAM. |
| DDS_ACM | <ul style="list-style-type: none"> • Contains POUs defined by Danfoss (name starting with DD_) and provide the functionality for the Auxiliary Capacitors Module (ACM 510). • The names of the POUs that target the ACM 510 all end with _ACM. |
| DDS_Intern | <ul style="list-style-type: none"> • Contains POUs that are needed internally for the libraries. • Do not use these POUs in an application. |

NOTICE

- Do not remove these libraries otherwise the Danfoss servo motion libraries will not work.

6.13.4 Importing Devices into TIA

NOTICE

- For each physical servo drive, PSM 510, DAM 510, or ACM 510, add 1 entry to the PROFINET® Ethernet network in the *Hardware Catalog*.

Procedure:

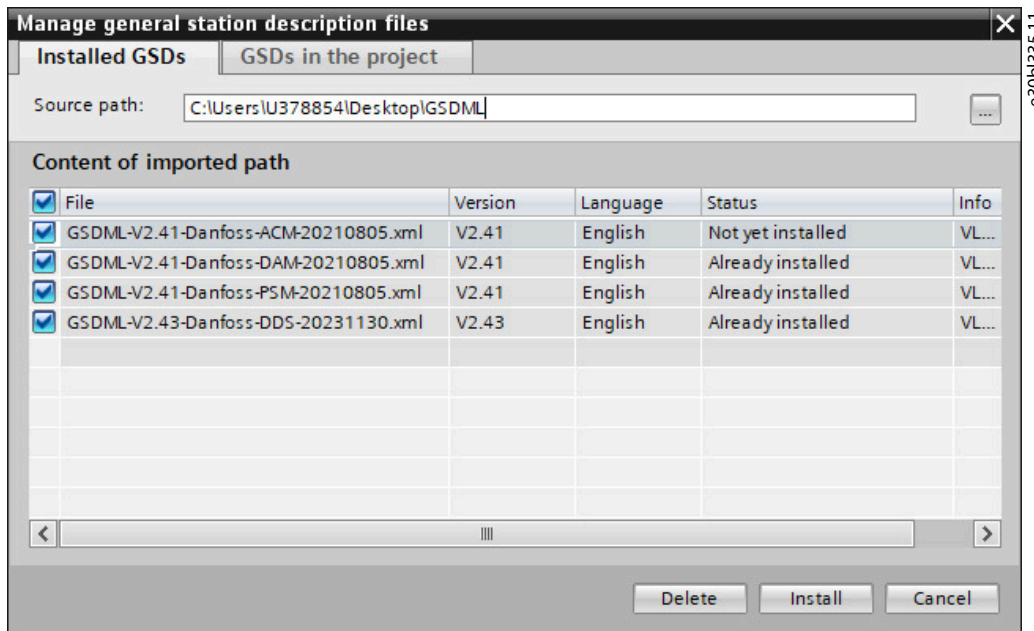

Figure 78: Importing Devices into TIA

1. Open the *Hardware Catalog*.
2. Select *Options* → *Manage general station description files*.
3. In tab *Installed GSDs* [1], select the *Source path* [2] where the files are located.
4. To add a servo drive, select 1 of the xml files [3] and click on *Install*. In the filename, 2.xx represents the version number and yyyyymmdd represents the date.

- o GSDML-V2.xx-Danfoss-DDS-yyyyymmdd.xml

5. Repeat steps 2 and 3 for:

- o Power Supply Module (PSM 510):
 - GSDML-V2.xx-Danfoss-PSM-yyyyymmdd.xml
- o Decentral Access Module (DAM 510);
 - GSDML-V2.xx-Danfoss-DAM-2Port-IRT-yyyyymmdd.xml
 - GSDML-V2.xx-Danfoss-DAM-3Port-RT-yyyyymmdd.xml
 - GSDML-V2.xx-Danfoss-DAM-yyyyymmdd.xml
- o Auxiliary Capacitors Module (ACM 510):
 - GSDML-V2.xx-Danfoss-ACM-yyyyymmdd.xml

6.13.5 Creating a Network in TIA

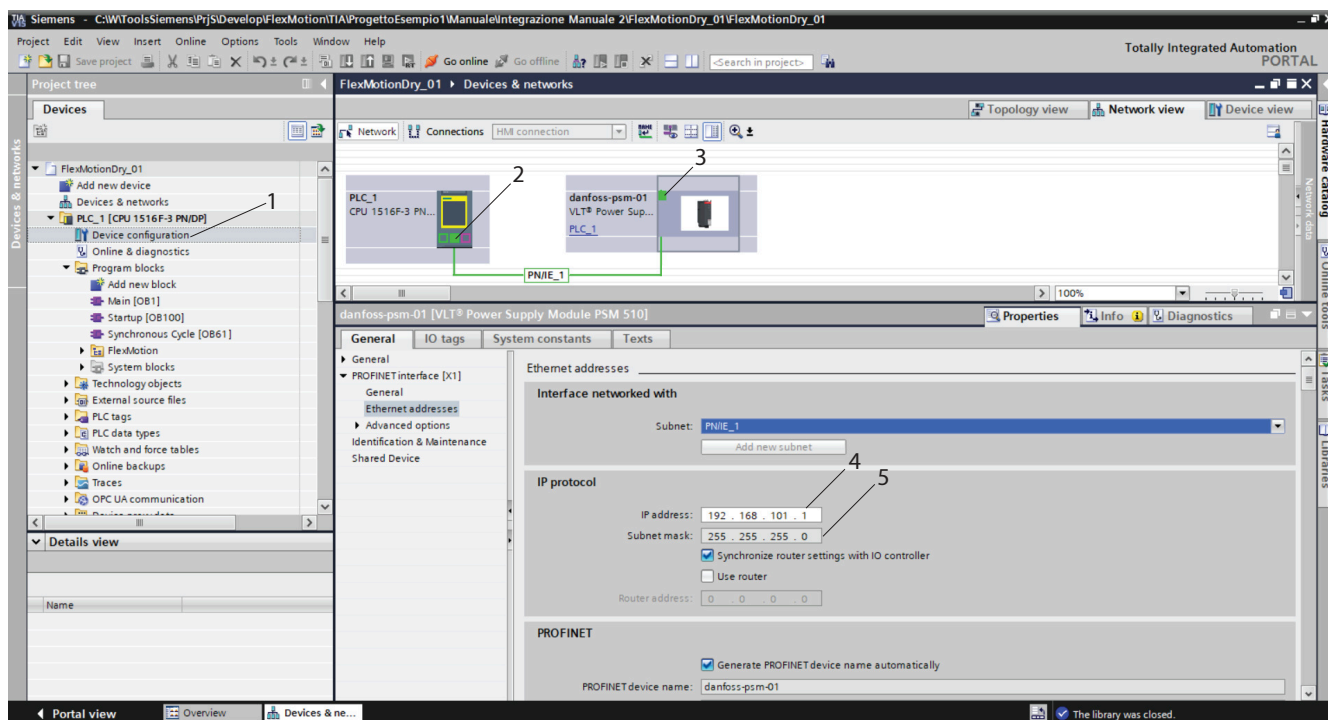

e30b255.10

Figure 79: Creating a Network

Procedure:

1. In the *Devices* window, select *Device configuration* [1] and add a PSM 510.
2. Assign the PSM 510 to the PLC_1 by dragging the middle square under the PLC icon [2] onto the square at top left of the PSM 510 icon [3]. The PN/IE_1 network is created automatically.
3. Assign the PROFINET device name, IP address, and subnet mask to the PSM 510:
 - a. Right-click on the PSM 510 icon.
 - b. Select the tab *General*.
 - c. Select *PROFINET interface [X1]* and then *Ethernet addresses*.
 - d. Enter the IP address 192.168.101.1 [4].
 - e. Enter the subnet mask 255.255.255.0 [5].
4. Repeat steps 1–3 to add a DAM 510, ACM 510, ISD 520, or DSD 520.

5. In the *Devices & networks* window, select *Topology view* [1] and connect the devices by dragging and dropping the icons.

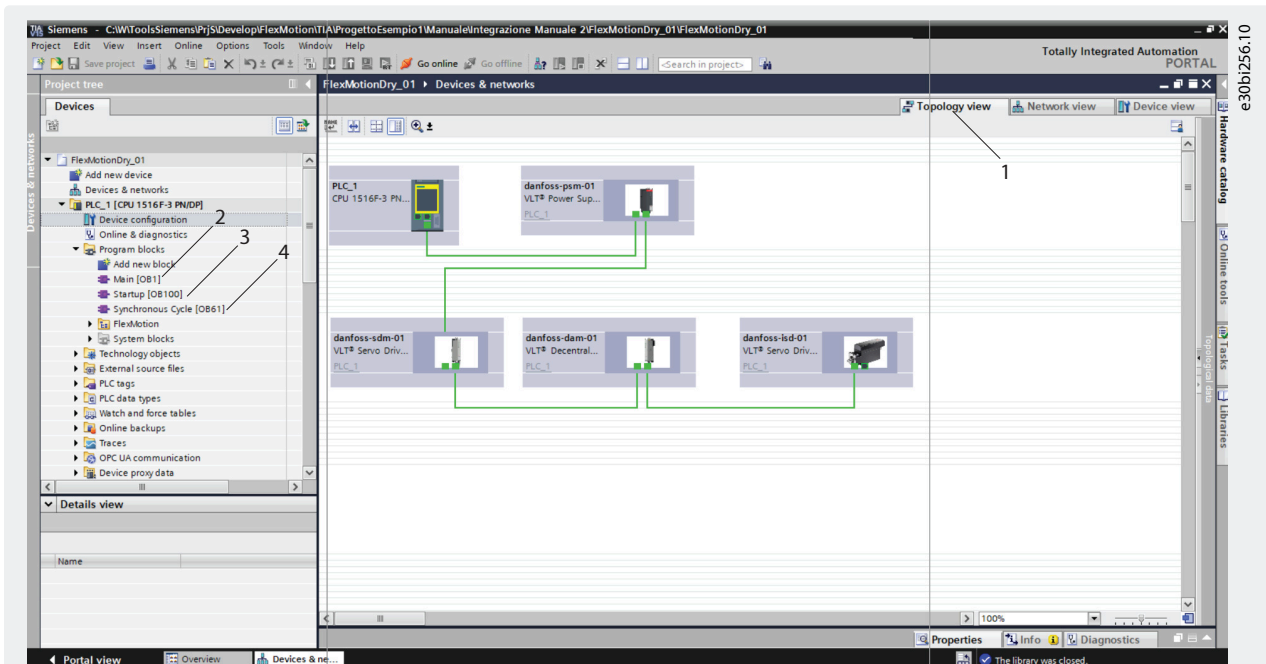

Figure 80: Devices and Networks Window

6. Remove any existing *MAIN [OB1]* operation block:
 - a. In the *Project Tree*, expand the *Program blocks* entry.
 - b. Right-click on operation block *Main [OB1]* [2] then select *Delete* in the drop-down menu.
7. Add a new *MAIN [OB1]* operation block [2] and create operation blocks for *Startup [OB100]* [3], and *Synchronous Cycle [OB61]* [4]:
 - a. In the *Project Tree*, expand the *Program blocks* entry.
 - b. Double-click on *Add new block*.
 - c. In the *Add new block* window, select *Organization block*.
 - d. Select organization block *MAIN [OB1]* from the list.
 - e. Set the language to *SCL* and activate the radio button *Automatic*.
 - f. Click on *OK*.
 - g. Repeat for *Startup [OB100]* and *Synchronous Cycle [OB61]*.
8. Verify SyncDomain:

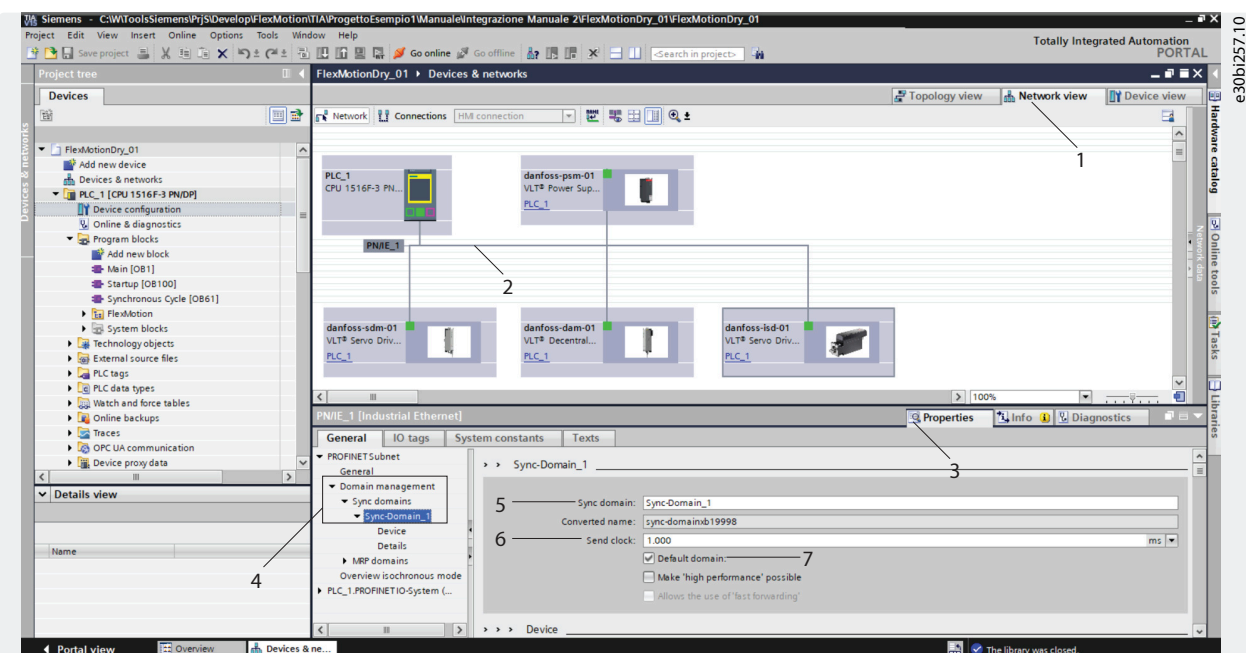

Figure 81: Verifying SyncDomain

- a. Open *Network view* [1] and select the *Ethernet subnet* [2] in which the sync domain is set up.
 - b. Open the Ethernet subnet properties.
 - c. In the local navigation [4], select entry *Domain management* → *Sync domains* → *Sync-Domain_1*.
 - d. In the field *Sync Domain* [5], change the name as desired.
 - e. In the field *Send clock* [6], select the desired value from the drop-down menu.
 - f. Activate the *Default domain* checkbox [7] to make this sync domain the default domain.
9. Verify that all system components have the *Sync slave* role:

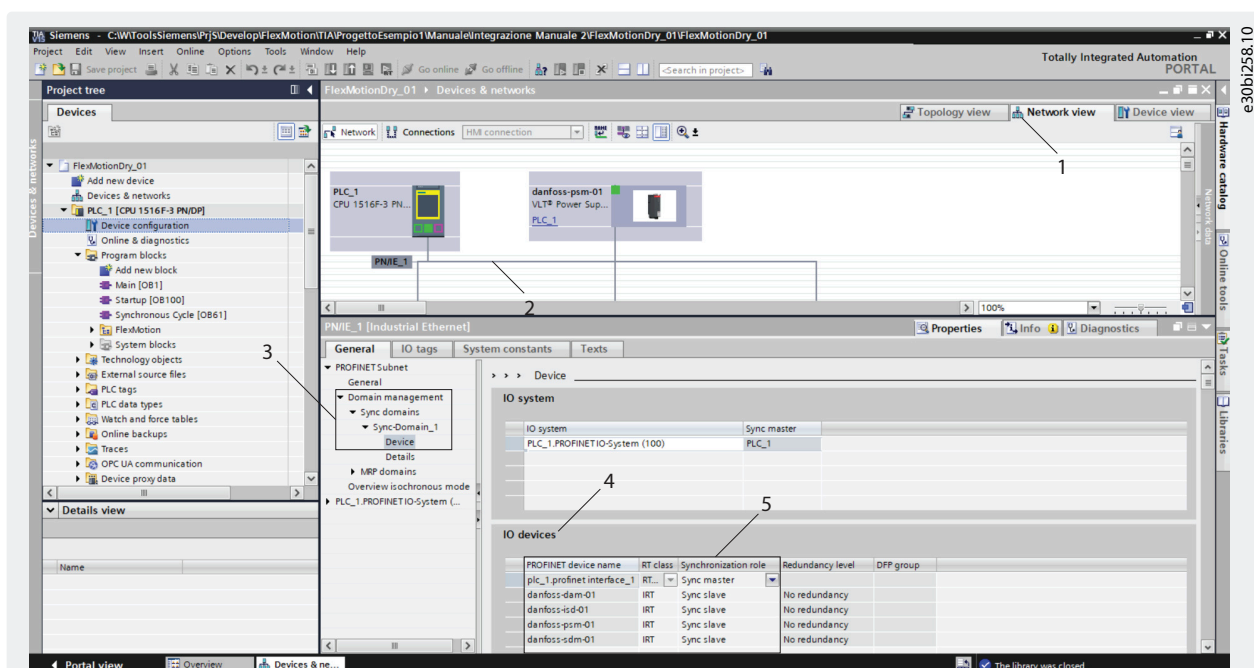

Figure 82: Sync Slave

- a. Open *Network view* [1] and select the Ethernet subnet in which the sync domain is set up.

- b. Open the Ethernet subnet [2] properties.
 - c. In the local navigation [3], select entry *Domain management* → *Sync domains* → *Sync-Domain_1* → *Device*.
 - d. Select the I/O devices.
 - e. Verify that all system components are present and set to *Sync slave*.
10. Select the telegram properties of each system component:

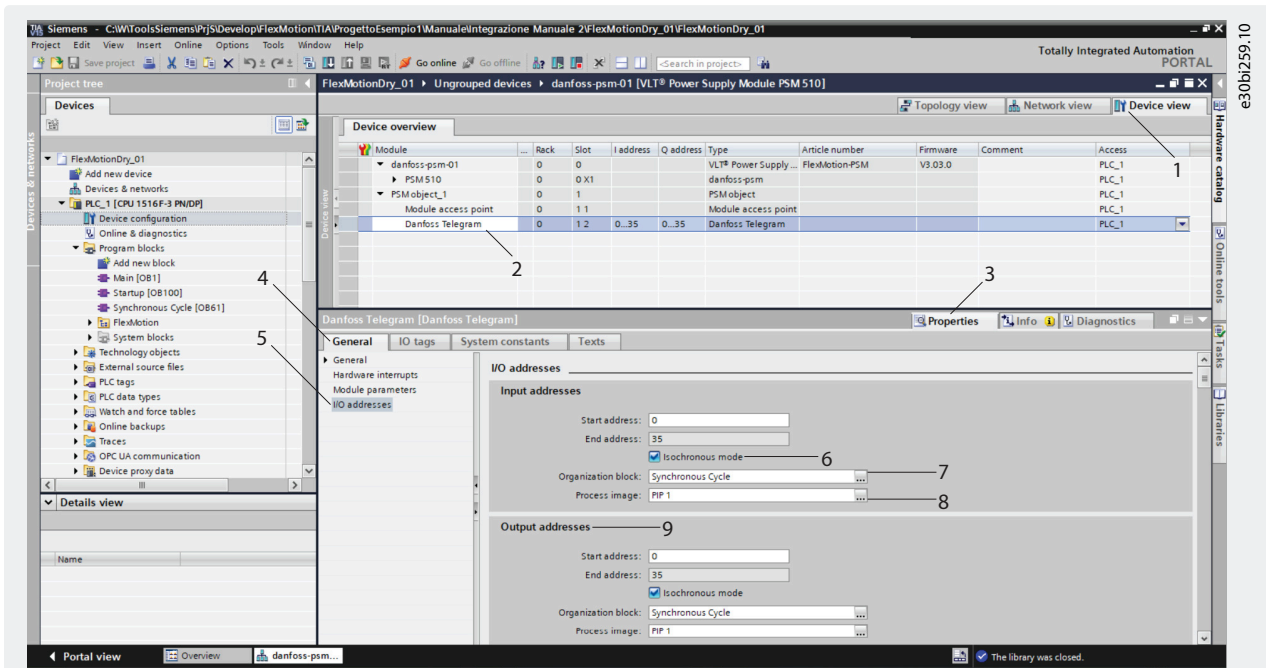

Figure 83: Telegram Properties

- a. Open *Device view* [1].
- b. Select *Danfoss Telegram* [2].
- c. In the *Properties* window [3], select the *General* tab [4] and then entry *I/O addresses* [5].
- d. In the *Input addresses* section, activate the checkbox for *Isochronous mode* [6] then set field *Organization block* [7] to *Synchronous Cycle* and field *Process image* [8] to *PIP 1*.
- e. Repeat these settings in the *Output addresses* section [9].
- f. Repeat this procedure for each system component.

11. Activate the isochronous mode for each system component:

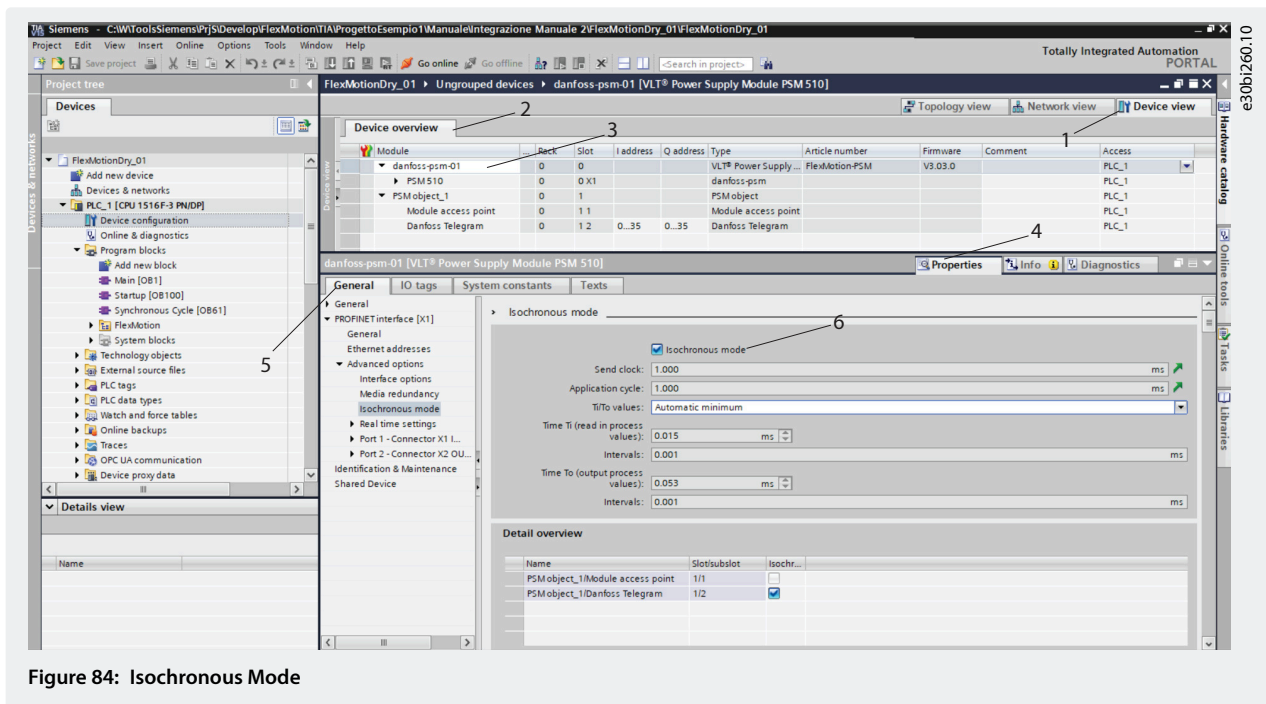

Figure 84: Isochronous Mode

- Open *Device view* [1].
- In section *Device overview* [2], click on *danfoss-psm-01* [3].
- In the *Properties* window [4], select the *General* tab [5] and then menu entries *PROFINET interface [X1]* → *Advanced options* → *Isochronous mode*.
- Activate the checkbox for *Isochronous mode* [6].
- Repeat these settings for each system component.

6.14 Programming Guidelines for TIA

Recommendations for implementation:

- Danfoss system modules do not need a structure declared in global data block *FlexMotion_Data*. Instead, they can be directly addressed in each function block via their hardware identifier:

```

56 // Drive devices
57 #DD_ReadParameter_DDS_Instance(HwId := "danfoss-isd-Device_object_1");
58
59 #DD_StoreParameters_DDS_Instance(HwId := "danfoss-isd-Device_object_1");
60
61 #DD_WriteParameter_DDS_Instance(HwId := "danfoss-isd-Device_object_1");
62
63 #DD_FeedbackAdjustment_DDS_Instance(HwId := "danfoss-isd-Device_object_1");
64

```

Figure 85: Parameter_DDS_Program

- Each Danfoss device in the project has a hardware identifier that is assigned automatically by TIA Portal during configuration and is shown in menu [PLC tags → Show all tags → System Constants]. This hardware identifier can be used to address and identify the module and must be assigned to the *HardwareId* input parameter of the appropriate function block for proper communication with the device:

| ▼ Static | | | | |
|----------|--------|----------------|--|--|
| ▀ | Psm_01 | "PSM_REF" | | |
| ▀ | Dam_01 | "DAM_REF" | | |
| ▀ | Isd_01 | "AXIS_REF_DDS" | | |
| ▀ | Dsd_01 | "AXIS_REF_DDS" | | |

```

1 // PSM
2 // =====
3 #Psm_01.HardwareId := "danfoss-psm~PSM_object_1~Danfoss_Telegram";
4
5 // DAM
6 // =====
7 #Dam_01.HardwareId := "danfoss-dam~DAM_object_1~Danfoss_Telegram";
8
9 // ISD
10 // =====
11 #Isd_01.HardwareId := "danfoss-isd~Device_object_1";
12
13 // DSD
14 // =====
15 #Dsd_01.HardwareId := "danfoss-dsd~Device_object_1";
16

```

e30bm135.10

Figure 86: HardwareId

- Power modules (PSM 510, DAM 510, ACM 510) use the hardware id (numerical value or name) of the *Danfoss Telegrams* submodule, for example *danfoss-psm~PSM_object_1~Danfoss_Telegram*.
- Drive devices (ISD 520, DSD 520) use the hardware id (numerical value or name) of the *Module Access Point* submodule, for example *danfoss-isd~Device_object_1*.

Only assign this variable in the 1st PLC cycle for initialization. The structures to be used for each type of device are:

- ISD 520 and DSD 520: *AXIS_REF_DDS*
- PSM 510: *PSM_REF*
- DAM 510: *DAM_REF*
- ACM 510: *ACM_REF*
- Initialize parameters that usually do not change only once at the beginning of the program.
- Call up function blocks that reference the drive devices (*AXIS_REF_DDS*) in a cyclic task (for example, *OB 1*) to ensure that data transfer can take place without delays or conflicts.
- Function blocks that reference the power modules (*PSM_REF*, *DAM_REF*, *ACM_REF*) can be called in a cyclic task (for example, *OB 1*), but this is not required.
- Processing of incoming and outgoing telegrams is integrated into function blocks operating on power modules, meaning that explicit update of process inputs/outputs is not required.
- Call up function blocks that provide status or error information with *Enable input* at the beginning of the program.
- Use 1 instance of function block *MC_Power_DDS* for every axis to control its power stage. Call up this function block in every PLC cycle.
- Use 1 instance of function block *DD_Power_PSM* for every PSM 510 to control the DC-link voltage on the output lines. Call up this function block in every PLC cycle.
- Use 1 instance of function block *DD_Power_DAM* for every DAM 510 to control the DC-link voltage on the output lines. Call up this function block in every PLC cycle.

- Use 1 instance of function block `DD_Power_ACM` for every ACM 510 to control the DC-link voltage on the output lines. Call up this function block in every PLC cycle.
- Call up function blocks that execute (motion) commands at the end of the program.
- Do not use any UDTs, POUs, enumerations, or constants starting with the prefix `iDD_`.
- Do not change the reference to the axis on a function block while it is busy.

6.15 VLT® Servo Toolbox Software

6.15.1 Overview

The VLT® Servo Toolbox is a standalone PC software designed by Danfoss. It is used for parameterization and diagnostics of the system modules. It is also possible to operate the devices in a non-productive environment.

NOTICE

- The VLT® Servo Toolbox software must be allowed for every firewall profile (private/public/domain).

The VLT® Servo Toolbox contains several subtools that provide various functionalities.

Table 33: Important Subtools

| Subtool | Description |
|-------------------------|--|
| Scope | For visualization of the tracing functionality of the servo drives, the Power Supply Module (PSM 510), the Decentral Access Module (DAM 510), and the Auxiliary Capacitors Module (ACM 510). |
| Parameter list | For reading/writing parameters. |
| Firmware update | For updating the firmware on the devices. |
| Drive control | For operating the servo drives for testing purposes. |
| PSM control | For operating the Power Supply Module (PSM 510) for testing purposes. |
| DAM control | For operating the Decentral Access Module (DAM 510) for testing purposes. |
| ACM control | For operating the Auxiliary Capacitors Module (ACM 510) for testing purposes. |
| CAM editor | For designing CAM profiles for the servo drives. |
| Configuration parameter | For setting up the motor and feedback parameters, and PID settings. |
| Drive commissioning | For motor feedback adjustment and inertia measurement. |
| Safety subtool | For setting up safety parameters for the servo drives with VLT®FlexSafety™ option. |

The detailed description of the VLT® Servo Toolbox functionality and the full parameter lists can be found in the *VLT® Servo Drive System ISD 520, DSD 520, MSD 520 (VLT® FlexMotion™) Programming Guide*.

6.15.2 System Requirements

To install the VLT® Servo Toolbox software, the PC must meet the following requirements:

- Supported hardware platforms: 32 bit, 64 bit
- Supported operating systems: Windows 10, Windows 11
- .NET framework version: 4.7
- Minimum hardware requirements: 512 MB RAM, Intel Pentium 4 with 2.6 GHz or equivalent, 20 MB hard disk space
- Recommended hardware requirements: Minimum 1 GB RAM, Intel Core i5/i7 or compatible

6.15.3 Installing the VLT® Servo Toolbox Software

Administrator rights are required to install the software with the Windows operating system. If necessary, contact a system administrator.

Procedure

1. Check that the system meets the system requirements specified in [6.15.2 System Requirements](#).
2. Download the VLT® Servo Toolbox installation file from the Danfoss website (<http://drives.danfoss.com>).
3. Right-click on the .exe file and select **Run as administrator**.
4. Follow the on-screen instructions to complete the installation process.

6.15.4 VLT® Servo Toolbox Communication

6.15.4.1 Overview

This section describes the Ethernet-specific network interface settings needed by the VLT® Servo Toolbox. There are 2 basic communication methods: direct communication and indirect communication. Their particular network settings are described in the respective subchapters.

Read and perform the steps with care. Incorrect network configurations can lead to loss of connectivity of a network interface.

6.15.4.2 Firewall

Depending on the firewall settings and the fieldbus used, the messages sent and received by the VLT® Servo Toolbox may be blocked by the firewall on the VLT® Servo Toolbox host system. This may lead to a loss of communication and the inability to communicate with the devices on the fieldbus. Therefore, ensure that the VLT® Servo Toolbox is allowed to communicate through the firewall on the VLT® Servo Toolbox host system. Inappropriate changes to firewall settings may lead to security issues.

NOTICE

- When using a dedicated network interface, the VLT® Servo Toolbox must be allowed to communicate specifically through this network interface.

6.15.4.3 Indirect Communication

6.15.4.3.1 Overview

Communication between ISD 520/DSD 520 devices and the VLT® Servo Toolbox through a PLC is called indirect communication.

Ethernet-based fieldbus communication (marked **A** in the graphic) takes place between the PLC and the ISD 520/DSD 520 devices.

However, there is non-fieldbus communication between the PLC and the VLT® Servo Toolbox host system.

In the scenario shown, the PLC has the master function and uses cyclic communication with the devices. Therefore, not all functionalities of the VLT® Servo Toolbox, for example, the drive control, can be used.

The restrictions when using indirect communication are detailed in the *VLT® Servo Drive System ISD 520, DSD 520, MSD 520 (VLT® FlexMotion™) Programming Guide*.

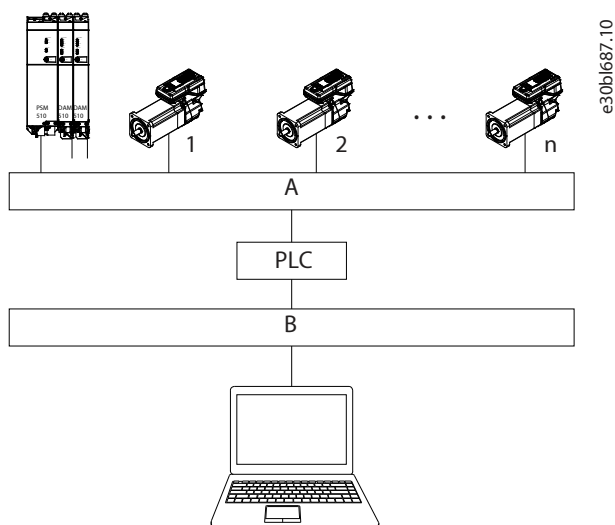

Figure 87: Logical View of Indirect Ethernet-based Fieldbus Communication (Communication via PLC)

| | | | |
|---|----------|---|--------------------------------|
| A | Fieldbus | B | VLT® Servo Toolbox host system |
|---|----------|---|--------------------------------|

NOTICE

- The logical view only shows the connectivity from a high-level software perspective and does not reflect the actual physical topology of the network.

6.15.4.3.2 Network Settings for Indirect Communication

Any network interface can be used to communicate through a PLC. A dedicated network interface is not required.

When establishing the communication through a PLC, the VLT® Servo Toolbox configures a routing table using the selected *Network Address Translation (NAT)*. Adding a route to the Windows routing table requires administrator privileges. Therefore, administrator credentials may be requested when initializing the connection.

6.15.4.3.3 Enabling Indirect Communication

Carry out the following steps to enable indirect communication.

NOTICE

When observing the network packets via Wireshark®, checksum offloading often causes confusion as the network packets to be transmitted are handed over to Wireshark® before the checksums have been calculated. Wireshark® shows these empty checksums as invalid, even though the packets contain valid checksums when they leave the network hardware later. Use 1 of these 2 methods to avoid this checksum offloading problem:

- Turn off the checksum offloading in the network driver if possible.
- Turn off the checksum validation of the specific protocol in the Wireshark® preferences.

Disable IPv6 on the network interfaces used for communication on the PC:

1. Open the *Network and Sharing Center*.
2. Select *Change adapter settings*.
3. Right-click on the network interface used for fieldbus communication and select *Properties*.
4. If the TCP/IPv6 is available for the network interface, disable it.

6.15.4.3.4 Additional Settings for Indirect Communication with EtherCAT®

Set the IP address of the EtherCAT® Master:

Procedure

1. Open the TwinCAT® System Manager.
2. Select *I/O-Configuration* → *I/O Devices* → *Device1 (EtherCAT®)* and check the IP-address in the *Adapter* tab. The IP-address of the PLC's network adapter may not be a link-local address (so not in the range of 169.254.0.1 to 169.254.255.254).
3. If necessary, change the IP-address inside the IPv4 Protocol properties according to the given operating system. This can be done on the controller locally or via *Remote Desktop*.

6.15.4.3.5 Activating the IP Routing in the EtherCAT® Master

The procedure described here may vary depending on the type of PLC and operating system installed.

Procedure

1. Open the *TwinCAT® System Manager*.
2. Click on *Advanced Settings...* via menu *I/O-Configuration* → *I/O Devices* → *Device1 (EtherCAT)* in the *EtherCAT* tab.
3. Select *EoE Support* in the *Advanced Settings* window.
4. Enable *Connect to TCP/IP Stack* in the *Windows Network* section.
5. Enable *IP Enable Router* in the *Windows IP Routing* section.
6. Reboot the PLC for the changes to take effect.

6.15.4.3.6 Setting the IP Address of the EtherCAT® Slave

The procedure for setting the IP Address of the EtherCAT® slave is valid for:

- ISD 520/DSD 520 servo drives
- Power Supply Module (PSM 510)
- Decentral Access Module (DAM 510)
- Auxiliary Capacitors Module (ACM 510)

NOTICE

- The last number of the IP address is the ID that is used in the VLT® Servo Toolbox to identify the device.

Procedure

1. Open the TwinCAT® System Manager.
2. Click on *Advanced Settings...* under *I/O-Configuration* → *I/O Devices* → *Device1 (EtherCAT)* → *Box 1 (VLT® Decentral Access Module* → *Drive 2 (VLT® Integrated Servo Drive ISD 520)* in the *EtherCAT®* tab.
3. Select *Mailbox* → *EoE* in the *Advanced Settings* window.
4. Enable *Virtual Ethernet Port* and enter a valid IP-address.
5. Each slave in the configuration requires an IP-address. This address is reassigned with every transition from *INIT* to *Pre-Operational* state of the slave state machine. The IP communication of the slaves is deactivated per default.

6.15.4.3.7 Additional Settings for Indirect Communication with PROFINET®

Overview

Each PROFINET® device needs a device name and an IP address. The IP address and the device name are assigned by the I/O controller, when the connection to the I/O device is established.

For the automatic detection of accessible nodes via a PG/PC interface with TCP/IP, connect the nodes to the same physical Ethernet subnet as the PG/PC. If a node is located in a different physical Ethernet subnet, the IP address of the sought node can be specified.

To reach further nodes, accessible nodes provide the capability of adding IP addresses and subnets to the PG/PC interface. The new IP addresses and subnets are then added to the Ethernet interface of the PG/PC.

NOTICE

- If >1 Danfoss servo drive is used in the same PROFINET® network, each servo drive must have a different name and IP address.
- The last number of the IP address is the ID that is used in the VLT® Servo Toolbox software to identify the device.

NOTICE

- IP addresses and subnets can also be added using PRONETA.

6.15.4.4 Direct Communication

6.15.4.4.1 Overview

For Ethernet-based fieldbus communication (direct communication), the VLT® Servo Toolbox must use a dedicated network interface on the VLT® Servo Toolbox host system. Do not use this network interface simultaneously for any other communication.

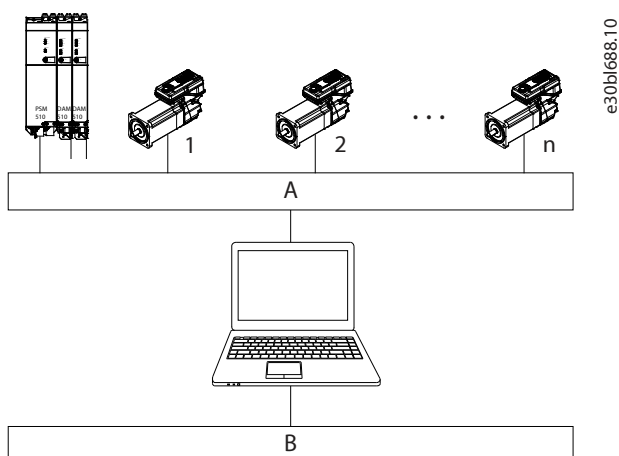

Figure 88: Logical View of Direct Ethernet-based Fieldbus Communication

| | |
|---------------------------------------|--------------------------------|
| A | B |
| Ethernet-based fieldbus communication | VLT® Servo Toolbox host system |

NOTICE

- The logical view only shows the connectivity from a high-level software perspective and does not reflect the actual physical topology of the network.

6.15.4.4.2 Network Settings for Direct Communication with Ethernet POWERLINK®

Disable all network protocols except TCP/IPv4 on the network interface used for direct Ethernet POWERLINK® communication. This prevents other PC software or the operating system using this network interface for other tasks, such as file and printer sharing and network discovery. Disabling these protocols reduces the number of non-relevant packets sent over the network interface and thus reduces the overall network load.

6.15.4.4.3 Disabling Unused Protocols on the Network Interface on the PC

Procedure

1. Open the *Network and Sharing Center*.

2. On the left, click on *Change adapter settings*.
3. Right-click on the network interface used for fieldbus communication and select *Properties*.
4. Uncheck all checkboxes except the one for *Internet Protocol Version 4 (TCP/IPv4)*.
5. Disable the *IPv4 Checksum offload* on the network interfaces as described in [6.15.4.3.3 Enabling Indirect Communication](#).

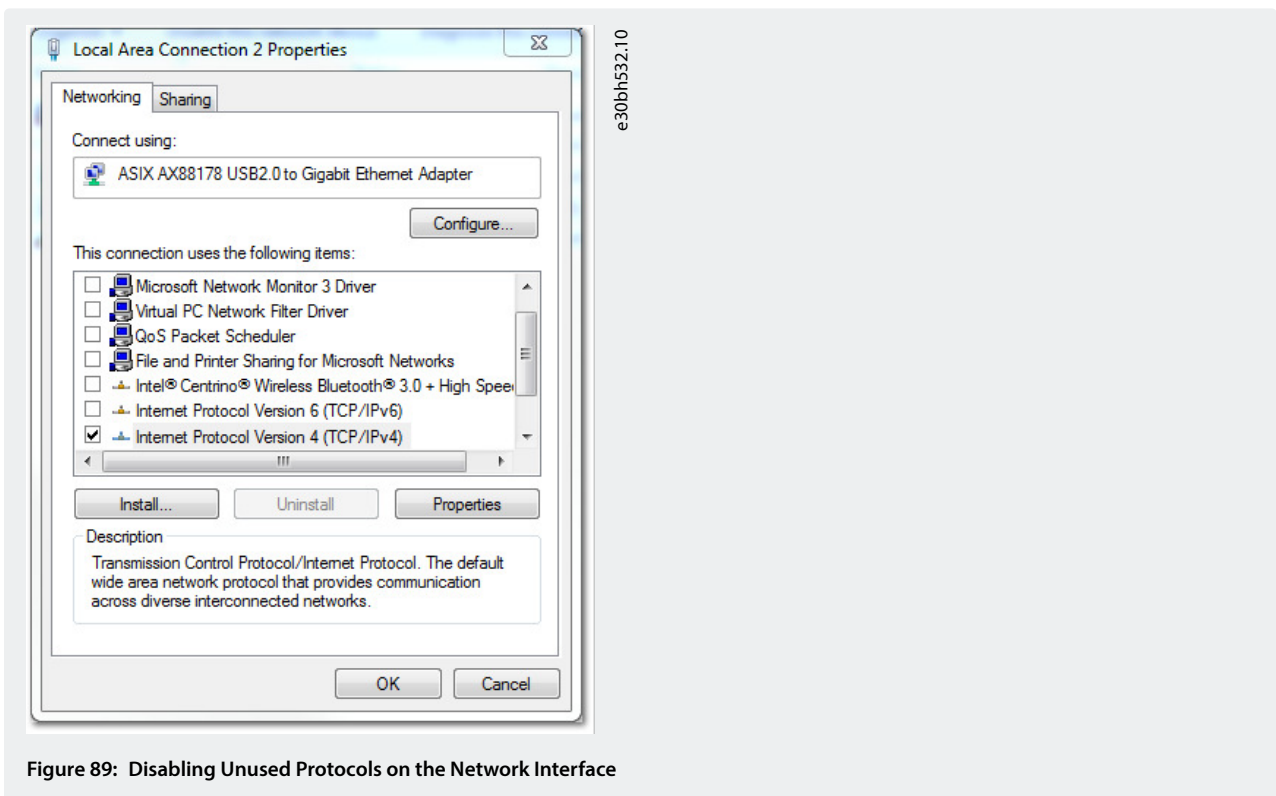

Figure 89: Disabling Unused Protocols on the Network Interface

6.15.4.4.4 Setting the Correct Ethernet POWERLINK® Master IP Address

Procedure

1. Open the *Network and Sharing Center*.
2. On the left, click on *Change adapter settings*.
3. Right-click on the network interface used for fieldbus communication and select *Properties*.
4. Click on *Internet Protocol Version 4 (TCP/IPv4)* (the checkbox must be checked) and then click on *Properties*.
5. Select *Use the following IP address* and use 192.168.100.240 as the IP address and 255.255.255.0 as the subnet mask. Leave all other fields empty.

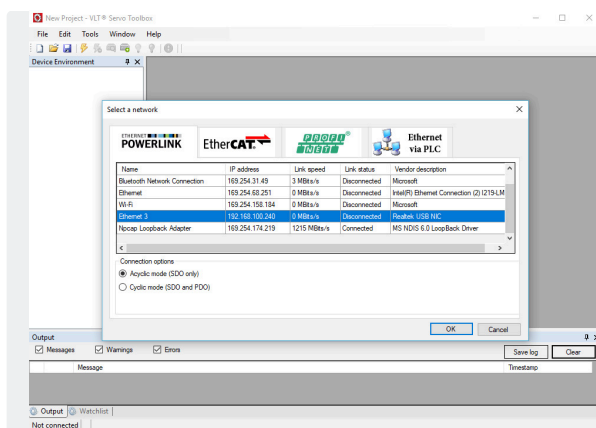

Figure 90: Internet Protocol Version 4 (TCP/IPv4) Properties

6.15.4.4.5 Network Settings for Direct Communication with EtherCAT®

Disable all network protocols except TCP/IPv4 on the network interface used for direct EtherCAT® communication. This prevents other PC software or the operating system using this network interface for other tasks, such as file and printer sharing and network discovery. Disabling these protocols reduces the number of non-relevant packets sent over the network interface and thus reduces the overall network load.

6.15.5 VLT® Servo Toolbox Commissioning

6.15.5.1 Step 1: Opening the Main Window

The *Main Window* is the basis for all VLT® Servo Toolbox functionalities. It consists of the following components:

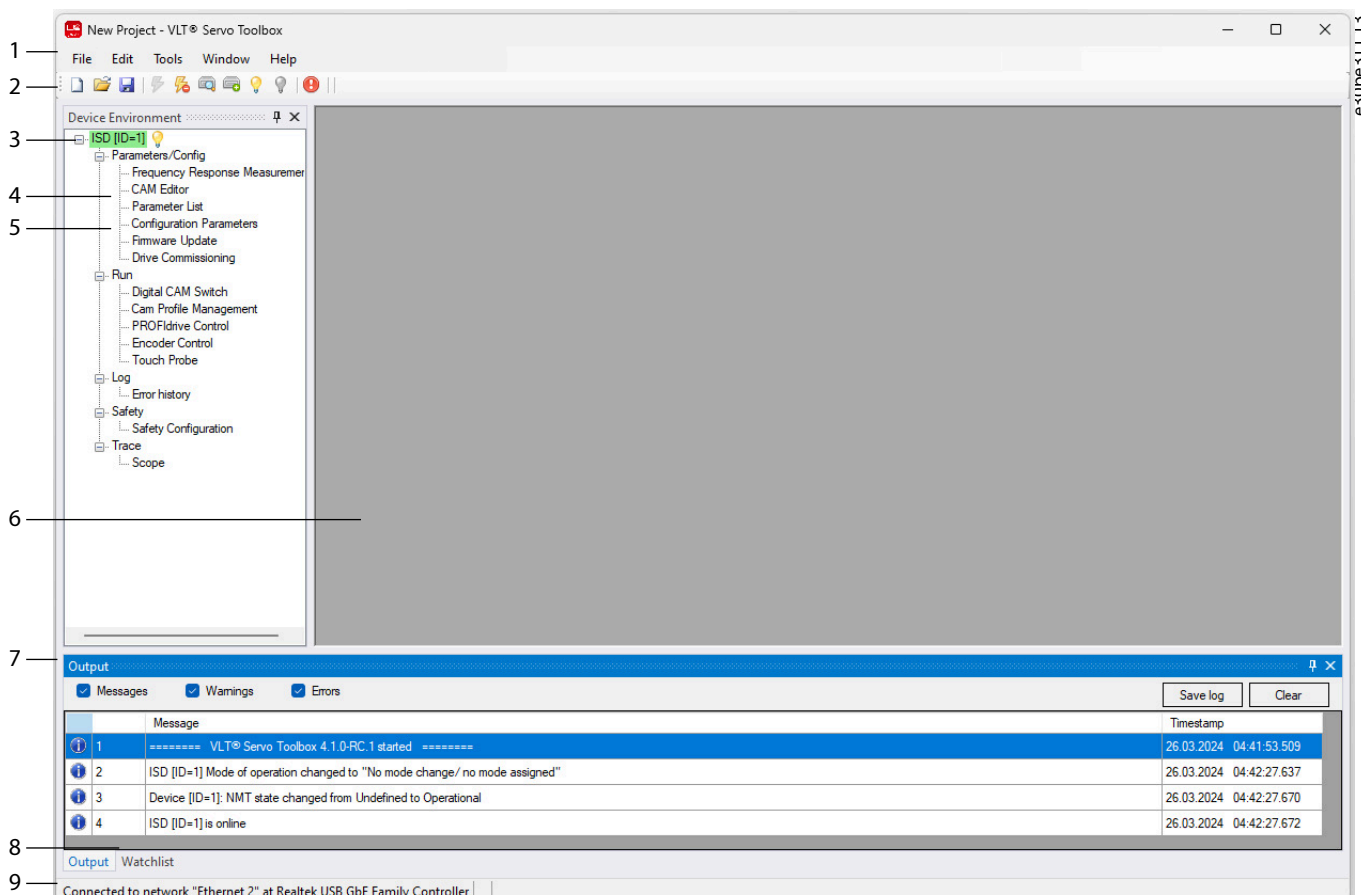

Figure 91: Main Window

Table 34: Main Window Description

| Legend number | Name | Description |
|---------------|--------------------------------------|---|
| 1 | Menu bar | Contains the general functionalities for saving and loading projects, managing connections, showing and changing settings, managing open subtools, and showing help contents. |
| 2 | Tool bar | Contains shortcuts for saving and loading projects, connecting to and disconnecting from networks, automatic searching for online devices, and manually adding devices. |
| 3 | Online status and state information | <p>Online devices are indicated by a glowing light bulb next to the device ID.</p> <ul style="list-style-type: none"> An online device is a logical device for which a physical device exists that the VLT® Servo Toolbox is connected to. The color indicates the state of the device and is device-specific. |
| | Offline status and state information | <p>Offline devices are indicated by a gray light bulb next to the device ID.</p> <ul style="list-style-type: none"> An offline device is a logical device without a corresponding physical device. An offline device can represent a saved device configuration or state, for example for offline analysis or troubleshooting. It also contains pre-configured parameter values to be written to a physical device. |
| 4 | Subtools | A subtool is opened by double-clicking its name in the <i>Device Environment</i> , or by selecting the entry and pressing the <i>Enter</i> key on the keyboard. |
| 5 | Device environment | <p>The <i>Device Environment</i> section of the <i>Main Window</i> lists all logical devices managed by the VLT® Servo Toolbox, visualizes their states, and serves as the user interface for accessing the device functionalities.</p> <p>The <i>Device Environment</i> window lists all available subtools for each added device.</p> <p>See the <i>VLT® Servo Drive System ISD 520, DSD 520, MSD 520 (VLT® FlexMotion™) Programming Guide</i> for further information on the subtools.</p> |
| 6 | Workspace | This is the space for hosting the subtools and its size depends on the <i>Main Window</i> size. The subtools can be maximized, minimized, horizontally or vertically aligned, or cascaded. |
| 7 | Watchlist window | Evaluates the parameter values of 1 or more devices by cyclically reading them from the devices. Allows parameter values to be logged and saved to a text file. It is also possible to modify/write values in the watchlist. |
| 8 | Output window | Shows operating information, warnings, and errors. Depending on the user settings, shows messages of up to 3 different logging levels (high, medium, and low). Used for showing advanced error and warning information. |
| 9 | Status strip | Shows the communication state of the VLT® Servo Toolbox. If connected to a network, it shows the used hardware interface (for example, network adapter) and the network name. |

6.15.5.2 Step 2: Connecting to Network

Pre-configure the appropriate communication settings to connect to a network (see [6.15.4.1 Overview](#)).

Procedure

1. In the *Main Window* toolbar, click on the *Connect to bus* icon to open the *Connect to Network* window.
2. Select the fieldbus type and the network interface to connect to.
3. Click on *OK* to connect.
4. Verify that the connection is successful by checking the status strip at the bottom of the *Main Window*.

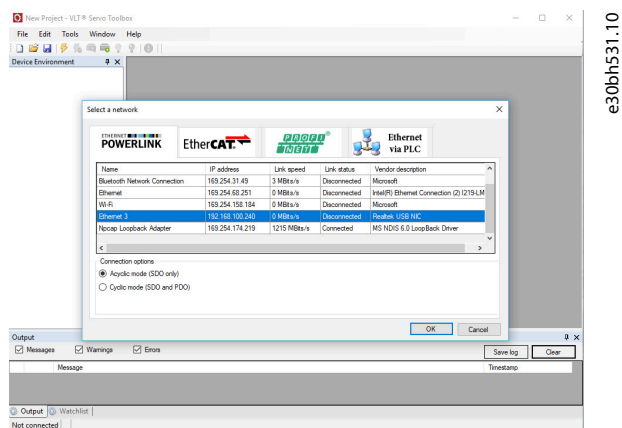

Figure 92: Connect to Network Window (Ethernet POWERLINK®)

e30bh531.10

6.15.5.3 Step 3: Scanning for Devices

Procedure

1. After verifying that the VLT® Servo Toolbox is connected to the selected network, click on the *Scan for Devices* icon in the toolbar to trigger the device scan procedure.

NOTICE

- If connected to an Ethernet POWERLINK® network in cyclic mode, select the scan range (minimum and maximum IDs) in the next window to reduce the time needed for scanning. In all other cases, the complete ID range is scanned.

2. When the scan is complete, a list of available devices is shown in the *Select Devices* window. Select the devices to be added to the *Device Environment* and click on *OK*.
3. All selected devices appear in the *Device Environment* window and automatically go online (indicated by a glowing light bulb next to each device name).

6.16 Motion Library

6.16.1 Simple Programming Template

TwinCAT®

A basic sample PLC application for starting up the servo system with 1 Power Supply Module (PSM 510), 1 Decentral Access Module (DAM 510), and 2 axes is provided. The project *DDS_ServoMotion_SampleProject* can be downloaded from the Danfoss website (<http://drives.danfoss.com>).

Automation Studio™ :

Detailed information on how to open the sample project within the ISD package in Automation Studio™ can be found in the Automation Studio™ Help. Open the B&R Help Explorer and go to *Programming* → *Examples* → *Adding sample programs* and follow the instructions for library samples.

PROFINET®

The project *DDS_ServoMotion_SampleProject* is a basic sample PLC (C240PN) application for starting up the servo system with 1 Power Supply Module (PSM 510), 1 Decentral Access Module (DAM 510), and 2 axes.

6.16.2 Function Blocks

The PLC library provides function blocks that support the functionality of the servo system and comply with this standard: *PLCopen® Technical Specification Function blocks for motion control (Formerly Part 1 and Part 2) Version 2.0 March 17, 2011*.

In addition to the PLCopen® functionality, Danfoss offers further functions for the servo system.

The following PLCopen® characteristics apply to all function blocks:

- Commanding (using the inputs)
- Signaling (behaviour of the outputs)
- General calling conventions

NOTICE

- See the *VLT® Servo Drive System ISD 520, DSD 520, MSD 520 (VLT® FlexMotion™)* Programming Guide for further information on the available function blocks and their behavior.

7 Operation

7.1 DS402 Operating Modes

The ISD 520/DSD 520 servo drives implement several modes of operation. The behavior of the servo drive depends on the activated mode of operation. It is possible to switch between the modes while the servo drive is enabled. The supported modes of operation are according to CANopen® CiA DS 402 and there are also ISD-specific modes of operation. All supported modes of operation are available for EtherCAT®, Ethernet POWERLINK®, and PROFINET®. The various modes of operation are described in detail in the *VLT® Servo Drive System ISD 520, DSD 520, MSD 520 (VLT®FlexMotion™) Programming Guide*.

Table 35: Operating Modes

| Mode | Description |
|---------------------------------------|---|
| Inertia and friction measurement mode | This mode measures the inertia of an axis. It is used to measure the inertia of the servo drive and the external load, and to optimize the control loop settings. The friction effects are identified automatically. |
| Profile velocity mode | In <i>Profile velocity mode</i> , the servo drive is operated under velocity control and executes a movement with constant speed. Additional parameters, such as acceleration and deceleration, can be parameterized. |
| Profile position mode | In <i>Profile position mode</i> , the servo drive is operated under position control and executes absolute and relative movements. Additional parameters, such as velocity, acceleration, and deceleration, can be parameterized. |
| Profile torque mode | In <i>Profile torque mode</i> , the servo drive is operated under torque control and executes a movement with constant torque. Linear ramps are used. Additional parameters, such as torque ramp and maximum velocity, can be parameterized. |
| Homing mode | In <i>Homing mode</i> , the application reference position of the servo drive can be set. Several homing methods, such as homing on actual position, homing on block, limit switch, or home switch, are available. |
| CAM mode | In <i>CAM mode</i> , the servo drive executes a synchronized movement based on a master axis. The synchronization takes place with a CAM profile that contains slave positions corresponding to master positions. CAMs can be designed graphically with the DDS Toolbox software, or can be parameterized via the PLC. The guide value can be provided by an external encoder, virtual axis, or the position of another axis. |
| Gear mode | In <i>Gear mode</i> , the servo drive executes a synchronized movement based on a master axis by using a gear ratio between the master and the slave position. The guide value can be provided by an external encoder, virtual axis, or the position of another axis. |
| Cyclic synchronous position mode | In <i>Cyclic synchronous position mode</i> , the trajectory generator of the position is located in the control device, not in the servo drive. |
| Cyclic synchronous velocity mode | In <i>Cyclic synchronous velocity mode</i> , the trajectory generator of the velocity is located in the control device, not in the servo drive. |

7.2 PROFIdrive Application Classes

For PROFINET® the only supported profile is PROFIdrive with its own specific application classes (for example, AC1, AC4, AC4-DSC) determined by the *Standard Telegram* selected via the PLC.

Table 36: PROFIdrive Application Classes

| Class | Description |
|---------|--|
| AC 1 | In application class 1 (AC1) mode a main setpoint (for example, speed setpoint) is used to control the servo drive in PROFINET® I/O. Speed control is handled entirely within the servo drive. |
| AC 4 | Application class 4 (AC4) defines an interface between the speed setpoint interface and the actual position value interface, where speed control is executed on the servo drive and position control on the controller. The motion control for multiple axes is performed centrally, for example, by numerical control (NC). The position control loop is closed by the fieldbus. Clock synchronization is required to synchronize the clocks for the position control in the controller and for the speed control in the drives (PROFINET® with IRT). |
| AC4-DSC | Extension of AC4. Dynamic Servo Control functionality can be used to increase the rigidity and dynamic response of the control loop. PROFINET® with IRT is required. |

7.3 Motion Functions

Table 37: Motion Functions

| Function | Description |
|--------------------|--|
| Digital CAM switch | This functionality controls whether the digital output is enabled or disabled, depending on the axis position. It performs a function comparable to switches on a motor shaft. Forward and backward movements of the axis position are allowed. On and off compensation and hysteresis can be parameterized. |
| Touch probe | This functionality stores the position actual value at a rising or falling edge of the configured digital input. |
| Guide value | The guide value is used in all synchronous modes of operation (<i>CAM mode</i> and <i>Gear mode</i>). It is used as the master position within the synchronous modes. |

7.4 Operating Indicator Lights (LEDs)

The operating status of the servo drives, PSM 510, DAM 510, and ACM 510 is indicated via the indicator lights (LEDs) on each device.

7.4.1 Operating Indicator Lights (LEDs) on the ISD 520/DSD 520 Servo Drives

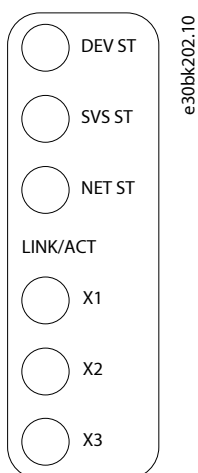

Figure 93: Operating Indicator Lights (LEDs) on ISD 520/DSD 520

Table 38: Operating Indicator Lights (LEDs) on ISD 520/DSD 520

| LED | Color | Flash status | Description |
|--|-----------|--------------------|---|
| DEV ST | Green | On | Servo drive is in state <i>Operation enabled</i> . |
| | | Flashing | Auxiliary voltage is applied. |
| | Red | On | Servo drive is in <i>Fault or Fault reaction active</i> state. |
| | | Flashing | DC-link voltage is not applied. |
| SVS ST | Green | On | 24 V safety supply is applied. |
| | | Off | 24 V safety supply is not applied. |
| NET ST | Green/red | Fieldbus dependent | Network status of the device (see the corresponding fieldbus standard). |
| LINK/ACT X1 (Link/activity status of <i>Hybrid In (X1)</i>) | Green | On | Ethernet link established. |
| | | Flashing | Ethernet link established and active. |
| | | Off | No link. |
| LINK/ACT X2 (Link/activity status of <i>Hybrid Out (X2)</i>) | Green | On | Ethernet link established. |
| | | Flashing | Ethernet link established and active. |
| | | Off | No link. |
| LINK/ACT X3 (optional) | Green | On | Ethernet link established. |
| | | Flashing | Ethernet link established and active. |
| | | Off | No link. |

7.4.2 Operating Indicator Lights (LEDs) on PSM 510

STATUS PSM

DEV

SVS ST

NET ST

e30bg576.11

LINK/ACT

X1

X2

Figure 94: Operating Indicator Lights (LEDs) on PSM 510

Table 39: Operating Indicator Lights (LEDs) on PSM 510

| LED | Color | Flash status | Description |
|--|-----------|--------------------|--|
| DEV | Green | On | Device is in state <i>Operation enabled</i> . |
| | | Flashing | Device is in state <i>Standby</i> or <i>Power-up</i> . |
| | Red | On | Device is in state <i>Fault</i> or <i>Fault reaction active</i> . |
| | | Flashing | Input mains is not applied. |
| SVS ST | Green | On | 24 V safety supply is applied. |
| | | Off | 24 V safety supply is not applied. |
| NET ST | Green/red | Fieldbus dependent | Network status of the device (see the corresponding fieldbus standard). ⁽¹⁾ |
| LINK/ACT X1 (Link/activity status of <i>In</i>) | Green | On | Ethernet link established. |
| | | Flashing | Ethernet link established and active. |
| | | Off | No link. |
| LINK/ACT X2 (Link/activity status of <i>Out</i>) | Green | On | Ethernet link established. |
| | | Flashing | Ethernet link established and active. |
| | | Off | No link. |

1) POWERLINK® and EtherCAT®: Refer to the corresponding fieldbus standard. For PROFINET®: Green = communication with master established; Orange = device is online and can be reached via the network; Blinking red = communication initialization is completed; Solid red = communication error.

7.4.3 Operating Indicator Lights (LEDs) on DAM 510

STATUS DAM

DEV

SVS ST

NET ST

AUX

e30bg577.11

LINK/ACT

X1

X2

X3

Figure 95: Operating Indicator Lights (LEDs) on DAM 510

Table 40: Operating Indicator Lights (LEDs) on DAM 510

| LED | Color | Flash status | Description |
|---|-----------|--------------------|--|
| DEV | Green | On | Device is in state <i>Operation enabled</i> . |
| | | Flashing | Device is in state <i>Standby</i> or <i>Power-up</i> . |
| | Red | On | Device is in state <i>Fault</i> or <i>Fault reaction active</i> . |
| | | Flashing | DC link is not applied at the input. |
| SVS ST | Green | On | 24 V safety supply is applied. |
| | | Off | 24 V safety supply is not applied. |
| NET ST | Green/red | Fieldbus dependent | Network status of the device (see the corresponding fieldbus standard). ⁽¹⁾ |
| AUX (State of the auxiliary voltage) | Green | On | Auxiliary voltage is applied to the output connector. |
| | | Off | Auxiliary voltage is not applied to the output connector. |
| | Red | On | Auxiliary voltage undervoltage detected in the hardware. |
| LINK/ACT X1 (Link/activity of <i>In</i>) | Green | On | Ethernet link established. |
| | | Flashing | Ethernet link established and active. |
| | | Off | No link. |
| LINK/ACT X2 (Link/activity status of <i>Hybrid Out</i>) | Green | On | Ethernet link established. |
| | | Flashing | Ethernet link established and active. |
| | | Off | No link. |
| LINK/ACT X3 (Link/activity status of <i>Out</i>) | Green | On | Ethernet link established. |
| | | Flashing | Ethernet link established and active. |
| | | Off | No link. |

1) POWERLINK® and EtherCAT®: Refer to the corresponding fieldbus standard. For PROFINET®: Green = communication with master established; Orange = device is online and can be reached via the network; Blinking red = communication initialization is completed; Solid red = communication error.

7.4.4 Operating Indicator Lights (LEDs) on ACM 510

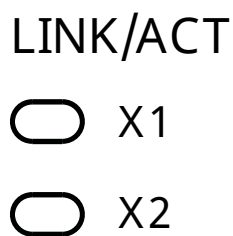
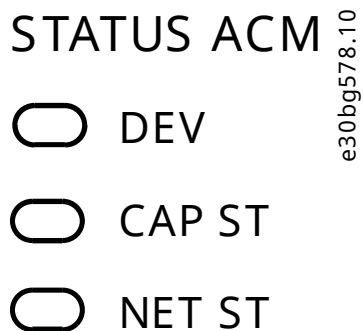

Figure 96: Operating Indicator Lights (LEDs) on ACM 510

Table 41: Operating Indicator Lights (LEDs) on ACM 510

| LED | Color | Flash status | Description |
|--|-----------|--------------------|--|
| DEV | Green | On | Device is in state <i>Operation enabled</i> . |
| | | Flashing | Device is in state <i>Standby</i> or <i>Power-up</i> . |
| | Red | On | Device is in state <i>Fault</i> or <i>Fault reaction active</i> . |
| | | Flashing | DC link is not applied at the input. |
| CAP ST | Green | On | Capacitors fully charged. |
| | | Flashing | Capacitors charging/discharging. |
| | | Off | Capacitors discharged. |
| NET ST | Green/red | Fieldbus dependent | Network status of the device (see the corresponding fieldbus standard). ⁽¹⁾ |
| LINK/ACT X1 (Link/activity of <i>ln</i>) | Green | On | Ethernet link established. |
| | | Flashing | Ethernet link established and active. |
| | | Off | No link. |

Table 41: Operating Indicator Lights (LEDs) on ACM 510 - (continued)

| LED | Color | Flash status | Description |
|--|-------|--------------|---------------------------------------|
| LINK/ACT X2 (Link/activity status of Out) | Green | On | Ethernet link established. |
| | | Flashing | Ethernet link established and active. |
| | | Off | No link. |

1) POWERLINK® and EtherCAT®: Refer to the corresponding fieldbus standard. For PROFINET®: Green = communication with master established; Orange = device is online and can be reached via the network; Blinking red = communication initialization is completed; Solid red = communication error.

8 Functional Safety Concept

8.1 Functional Description

The servo system integrates the safety function safe torque off (STO). The safety function is available in daisy-chain format, which is possible between all system modules except ACM 510 (cables are not included). The hybrid cable passes the STO signal from the Decentral Access Module (DAM 510) to all ISD 520/DSD 520 servo drives in the chain. Once STO is activated (safe state), no torque is generated on the ISD 520 servo drives, or on any motors connected to DSD 520, SDM 511 or SDM 512. Reset of the safety function and diagnostics can be carried out via the PLC.

NOTICE

- Use STO shielded wiring.
- Use the STO function when performing mechanical work on the servo system or affected area of a machine to avoid a mechanical hazard. However, the STO function does not provide electrical safety.

NOTICE

- The ISD 520/DSD 520 servo drives can also be ordered with the VLT® FlexSafety™ option, implementing advanced functional safety. See the *Advanced Functional Safety for VLT® FlexMotion™ Operating Guide* for the available safety functions and related safety capability.
- For VLT® FlexSafety™, the HMI of the device requires a password to inhibit unauthorized access.

8.2 Safety Precautions

WARNING

UNCONTROLLED MOVEMENT

External forces on the motor could cause an uncontrolled and hazardous movement that could result in death or serious injury.

- Equip the motor with additional measures for preventing uncontrolled and hazardous movement, for example, mechanical brakes.

WARNING

RISK OF ELECTRIC SHOCK

The STO function does **not** isolate mains voltage to the servo system or auxiliary circuits. Failure to isolate the mains voltage supply and wait for the specified discharge time to elapse could result in death or serious injury.

- Only perform work on electrical parts of the servo system or the ISD 520/DSD 520 servo drives after isolating the mains voltage supply and waiting for the discharge time to elapse.

WARNING

RISK OF RESIDUAL ROTATION

Due to failures in the power semiconductor of the drive, a residual rotation can result from a fault that could result in death or serious injury. The rotation can be calculated to angle = $360^\circ / (\text{number of poles})$.

- Take this residual rotation into consideration and ensure that it does not pose a safety risk.

WARNING**INDICATOR LIGHT (LED) STATUS RELIABILITY**

Status indicator lights (LEDs) are not reliable for safety functions.

- Only use status indicator lights for general diagnostics during commissioning and troubleshooting.

NOTICE

- After installing the STO function, perform a commissioning test. A passed commissioning test is mandatory after initial installation and after each change to the safety installation (see [8.8 Commissioning Test](#)).
- For advanced functional safety, perform a commissioning test to validate the safety functions and their safety properties for the whole system. See the *Advanced Functional Safety for VLT® FlexMotion™ Operating Guide*.

NOTICE

- If required, implement a manual reset function according to EN ISO 13849-1. For automatic restart without manual reset, observe the requirements detailed in paragraph 6.3.3.2.5 of EN ISO 12100:2010 or equivalent standard.

NOTICE

- Carry out a risk assessment to select the correct stop category for each stop function in accordance with EN 60204-1.
- When designing the machine application, consider the timing and distance for coast to stop (Stop Category 0 or STO). See EN 60204-1 for further information.
- All signals connected to the STO must be supplied by a PELV supply.

8.3 Qualified Personnel for Working with Functional Safety

The STO function can only be installed, programmed, commissioned, maintained, and decommissioned by qualified personnel. Qualified personnel for the functional safety concept are qualified electrical engineers, or persons who have received training from qualified electrical engineers and are suitably experienced to operate devices, systems, plant, and machinery in accordance with the general standards and guidelines for safety technology.

Furthermore, they must:

- Be familiar with the basic regulations concerning health and safety/accident prevention.
- Have read and understood the safety guidelines given in this guide.
- Have a good knowledge of the generic and specialist standards applicable to the specific application.

Users of power drive systems (safety-related) (PDS(SR)) are responsible for:

- Hazard and risk analysis of the application.
- The overall safety of the application.
- Identifying safety functions required and allocating SIL or PL to each of the functions, other subsystems, and the validity of signals and commands from them.
- Designing appropriate safety-related control systems, such as hardware, software, and parameterization.

8.4 Applied Standards and Compliance

Use of the STO function requires that all provisions for safety, including relevant laws, regulations, and guidelines, are satisfied.

The integrated STO function complies with the following standards:

- IEC 61508-1 to 2: 2010 SIL 2

- EN 61508-1 to 2: 2010 SIL 2
- IEC 61800-5-2: 2016 SIL 2
- EN 61800-5-2: 2017 SIL 2
- EN ISO 13849-1: 2015, PL d, Cat. 3
- EN ISO 13849-2: 2012, PL d, Cat. 3

The ISD 520/DSD 520 servo drives can be used in the application area of EN IEC 62061:2021 and where Stop Category 0 (uncontrolled stop), according to IEC 60204-1:2016 or EN 60204-1:2018, is needed.

8.5 Abbreviations and Conventions

Table 42: Safety-related Abbreviations and Conventions

| Abbreviation | Reference | Description |
|-------------------|------------------|---|
| Cat. | EN ISO 13849-1 | Category B, 1–4 |
| DC | – | Diagnostic coverage |
| FIT | – | Failure in time Failure rate: 1E-9/hour |
| HFT | EN IEC 61508 | Hardware fault tolerance HFT = n means that n + 1 faults may lead to a loss of the safety function. |
| MTTF _D | EN ISO 13849-1 | Mean time to failure – dangerous Unit: years |
| PFH | EN IEC 61508 | Probability of dangerous failures per hour Take this value into account if the safety device is operated in high demand mode or in continuous operating mode, where the frequency of demands for operation made on a safety-related system occurs more than once per year. |
| PL | EN ISO 13849-1 | Performance level A discrete level used to specify the capability of safety-related parts of a system to perform safety-oriented functions under foreseeable conditions. Levels: a–e. |
| SFF | EN IEC 61508 | Safe failure fraction [%] Proportion of safe failures and detected dangerous failures of a safety function or a subsystem as a percentage of all possible failures. |
| SIL | EN IEC 61508 | Safety integrity level |
| STO | EN IEC 61800-5-2 | Safe torque off |

8.6 Installation

Only Danfoss cables can be used for the installation of the servo system, however, cables from other suppliers can be used for the user connection to the STO terminal **STO DAM (Pins 3 and 4)** on the Decentral Access Module (DAM 510).

Safety relays that have a plus and minus switching output signal can be directly connected to the servo system to activate STO.

The example in [Figure 97](#) shows the basic connection to be made for the STO function. A suitable safety device to switch it off is not supplied by Danfoss. The STO is activated by opening STO+ and STO-.

Table 43: Activation of STO Function

| STO+ | STO- | STO function |
|------|------|-----------------|
| 24 V | GND | STO deactivated |
| Open | Open | STO activated |

NOTICE

- Do not exceed 30 V at the STO inputs.
- STO is activated if the plus input is between -3 V and +3 V.
- STO is deactivated if the plus input is between +21.6 V and +26.4 V.

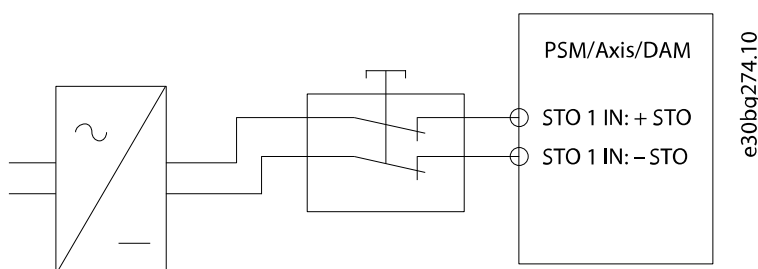

Figure 97: Safety Relay with Plus and Minus Switching Output

Signals with test pulses must not have test pulses of >1 ms. Longer pulses may lead to reduced availability of the servo system.

8.6.1 Protective Measures

- Install the system modules in an IP54 cabinet as per IEC 60529 or in an equivalent environment. A higher IP protection may be necessary for certain applications.

If external influences can affect the motor axis, for example, suspended loads, use additional measures, such as a safety holding brake, to eliminate hazards.

8.7 Application Example

An example of an application that can be put in safe torque off (STO) mode by a safety circuit is shown in [Figure 98](#).

Select the safety switch devices in accordance with the requirements of the application.

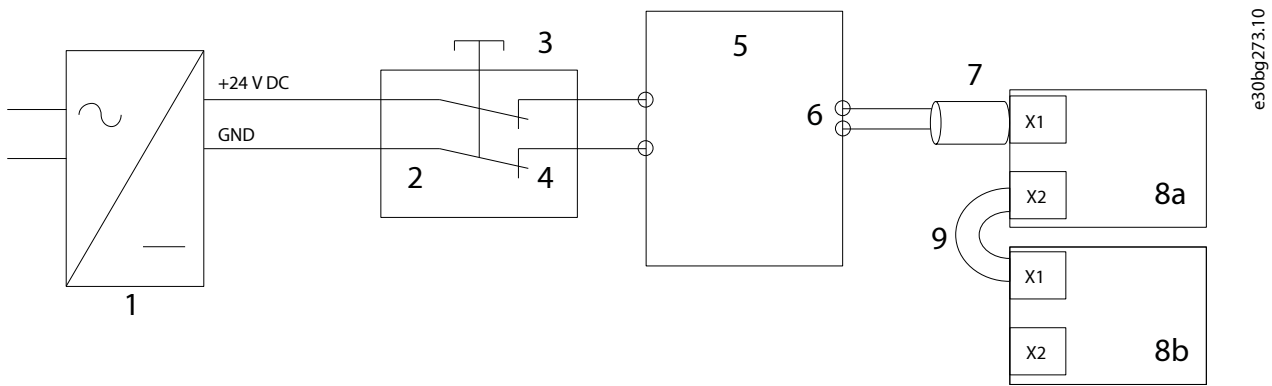

e30bg273:10

| | | | |
|----|-----------------------------------|----|------------------------|
| 1 | 24 V DC supply | 2 | Safety device |
| 3 | Emergency stop button | 4 | Safety device contacts |
| 5 | Decentral Access Module (DAM 510) | 6 | Hybrid cable |
| 7 | Feed-in cable | 8a | Servo drive |
| 8b | Servo drive | 9 | Loop cable |

Figure 98: Application Example: Safe Torque Off Function

8.8 Commissioning Test

NOTICE

- Perform a commissioning test according to standard EN/ISO 13849-1 for the whole servo system after installation of the STO function, after every change to the installed function, or after a safety fault.

There are 2 ways to implement the commissioning test depending on the method used to program the PLC, however, the steps of the test are the same:

- Using the Danfoss Library or the TwinCAT® Library.
- Bit-wise readout of the status.

8.8.1 Commissioning Test using Libraries

Depending on the application, 1 or both of the following libraries are required to program the commissioning test:

- Danfoss Library
 - MC_ReadAxisInfo_DDS
 - MC_ReadStatus_DDS
 - MC_ReadAxisError_DDS
 - MC_Reset_DDS
- TwinCAT® Library
 - MC_ReadStatus
 - MC_ReadAxisError
 - MC_Reset

Table 44: Commissioning Test using Libraries

| | Test steps | Reason for the test step | Expected result for Danfoss library | Expected result for TwinCAT® library |
|---|---|---|---|--|
| 1 | Run the application (all the servo drives are enabled). | Check that the application can run. | Application runs as expected. | Application runs as expected. |
| 2 | Stop the application. | – | All servo drives are at speed 0 RPM. | All servo drives are at speed 0 RPM. |
| 3 | Disable all the servo drives. | – | All servo drives are disabled. | All servo drives are disabled. |
| 4 | Enable STO. | Check that STO can be activated without error. | <i>MC_ReadAxisInfo_DDS</i> output <i>SafeTorqueOff</i> = True for all servo drives on the corresponding line. | – |
| 5 | Disable STO. | Check that STO can be deactivated without error. No reset is required. | <i>MC_ReadAxisInfo_DDS</i> output <i>SafeTorqueOff</i> = False for all servo drives on the corresponding line. | – |
| 6 | Run the application (all the servo drives are enabled). | – | Application runs as expected. | Application runs as expected. |
| 7 | Enable STO. | Check that errors are generated correctly when STO is activated while the servo drives are running. | Motors are torque free. Motors coast and stop after some time. <i>MC_ReadAxisInfo_DDS</i> output <i>SafeTorqueOff</i> = True and <i>MC_ReadStatus_DDS</i> output <i>ErrorStop</i> = True and <i>MC_ReadAxisError_DDS</i> output <i>AxisErrorID</i> = 0xFF80 on all enabled servo drives. | Motors are torque free. Motors coast and stop after some time. For enabled motors: <i>MC_ReadAxisInfo_DDS</i> output <i>SafeTorqueOff</i> = True and <i>MC_ReadStatus</i> output <i>ErrorStop</i> = True and <i>MC_ReadAxisError</i> output <i>AxisErrorID</i> = 0xFF80 on all enabled servo drives. |
| 8 | Try to run the application (enable 1 or more servo drives). | Checks that the STO function is working correctly. | Application does not run. | Application does not run. |
| 9 | Disable STO. | Check that the STO start is still inhibited by the error signal. | <i>MC_ReadAxisInfo_DDS</i> output <i>SafeTorqueOff</i> = False and <i>MC_ReadStatus_DDS</i> output <i>ErrorStop</i> = True | <i>MC_ReadStatus</i> output <i>ErrorStop</i> = True |

Table 44: Commissioning Test using Libraries - (continued)

| | Test steps | Reason for the test step | Expected result for Danfoss library | Expected result for TwinCAT® library |
|----|---|----------------------------------|---|--|
| 10 | Try to run the application (enable 1 or more servo drives). | Check whether reset is required. | Application does not run. | Application does not run. |
| 11 | Send a reset signal via <i>MC_Reset(_DDS)</i> . | – | <i>MC_ReadAxisInfo_DDS</i> output <i>SafeTorqueOff</i> = False and <i>MC_ReadStatus_DDS</i> output <i>ErrorStop</i> = False | <i>MC_ReadStatus</i> output <i>ErrorStop</i> = False |
| 12 | Try to run the application (all servo drives are enabled). | – | Application runs as expected. | Application runs as expected. |

8.8.2 Commissioning Test using PROFINET® Devices

Table 45: Commissioning Test using PROFINET® Devices

| | Test steps | Reason for the test step | Expected result |
|----|---|---|---|
| 1 | Run the application (all the servo drives are enabled). | Check that the application can run. | Application runs as expected. |
| 2 | Stop the application. | – | All servo drives are at speed 0 RPM. |
| 3 | Disable all the servo drives. | – | All servo drives are disabled. |
| 4 | Enable STO. | Check that STO can be activated without error. | No errors are present. The successful STO activation can be checked on the indicator lights (LEDs) on the devices. |
| 5 | Disable STO. | Check that STO can be deactivated without error. No reset is required. | No errors are present. The STO status can be checked on the indicator lights (LEDs) on the devices. |
| 6 | Run the application (all the servo drives are enabled). | – | Application runs as expected. |
| 7 | Enable STO. | Check that errors are generated correctly when STO is activated while the servo drives are running. | Motors are torque free. Motors coast and stop after some time. Error 0x11E is shown in object 0x603F on all servo drives. |
| 8 | Try to run the application (enable 1 or more servo drives). | Checks that the STO function is working correctly. | Application does not run. |
| 9 | Disable STO. | Check that the STO start is still inhibited by the error signal. | Error 0x11E is shown in object 0x603F on all servo drives. |
| 10 | Try to run the application (enable 1 or more servo drives). | Check whether a reset is required. | Application does not run. |

Table 45: Commissioning Test using PROFINET® Devices - (continued)

| | Test steps | Reason for the test step | Expected result |
|----|--|--------------------------|---|
| 11 | Send a reset signal via the PLC. | – | STO error 0x11E is cleared in all servo drives. |
| 12 | Try to run the application (all servo drives are enabled). | – | Application runs as expected. |

8.9 Operation of the STO Function

The STO function does not require any parameterization and is always enabled.

The ISD 520/DSD 520 servo drive provides STO status signals via the fieldbus.

All signals transmitted via the fieldbus are not part of the safety function and can only be used for operational purposes.

See the *VLT® Servo Drive System ISD 520, DSD 520, MSD 520 (VLT® FlexMotion™) Programming Guide* for:

- General information on how to access and map data objects.
- Information on a library provided to simplify the use of the fieldbus functions.

If the servo drive is enabled and STO is activated, an error code is issued.

If the drive is not enabled and STO is activated, it is not necessary to reset any STO error. It is sufficient to reapply the supply voltage to the STO terminals, before enabling the drive.

8.9.1 Error Codes

If bit 3 of the statusword is set, this indicates any faults that occur on the servo drive. If the fault occurred because of the STO circuit, the cause of the fault can be found in object 0x603F.

Table 46: Error Codes

| Error code | PROFINET® error code | Classification | Description | Reset |
|------------|----------------------|----------------|--|--------------------------|
| 0xFF80 | 0x11E | Fault | STO activated while the servo drive was enabled, or an attempt to enable the servo drive was made while STO was activated. | Reset via the PLC. |
| 0xFF81 | 0x11F | Safety fault | Servo drive internal diagnostic fault. | Carry out a power cycle. |
| 0xFF85 | 0x120 | Safety fault | Internal STO supply on the power card is not within limits. | Carry out a power cycle. |

Error code 0xFF80/0x11E can be a normal status of the application. In this case, the servo drive requires a reset signal from the PLC. To use the STO function in an application that requires a control guard (see ISO 12100 for details), this reset information can be given automatically by the PLC. All servo drives on the same line will show this fault at the same time. Carry out a check on the PLC to compare the fault of all servo drives on 1 line.

Error code 0xFF81/0x11F means that there is a fault on the servo drive that can only be reset by carrying out a power cycle. Complete the commissioning test after the power cycle. Operation of the servo system can only be resumed if the test is completed successfully. If error code 0xFF81/0x11F or 0xFF85/0x120 is issued again, contact Danfoss Service.

8.9.2 Fault Reset

To reset faults, change bit 7 of the controlword from 0 to 1. See the *VLT® Servo Drive System ISD 520, DSD 520, MSD 520 (VLT® FlexMotion™) Programming Guide* for further information.

8.10 Functional Safety Characteristic Data

Table 47: Functional Safety Characteristic Data

| Data | ISD 520/DSD 520 | PSM 510 | DAM 510 |
|---|--------------------------|---------|---------|
| General information | | | |
| Response time (from switching on the input until torque generation is disabled) | <100 ms | | |
| Lifetime | 20 years | | |
| Data for EN/ISO 13849-1 | | | |
| Performance level (PL) | d | – | – |
| Category | 3 | – | – |
| Mean time to dangerous failure (MTTF _D) | >100 years | – | – |
| Diagnostic coverage (DC) | Low | – | – |
| Data for IEC 61508 | | | |
| Safety integrity level (SIL) | 2 | – | – |
| Probability of failure per hour (PFH) | <4 x 10 ⁻⁹ /h | 0/h | 0/h |
| Subsystem classification | Type A | | |
| Diagnostic test interval | 1 year | | |

NOTICE

- The PSM 510, DAM 510, and ACM 510 do not contribute to the dangerous failure rate of the servo system and can therefore be excluded from safety-related calculations.
- Compliance to the claimed SIL and PL is only possible if the diagnostic test is executed once per year.

8.11 Maintenance, Security, and User Accessibility

Maintenance: Test the STO safety function at least once per year as follows:

1. Start the motor.
2. Remove the STO input voltage.
3. Verify that the motors stop running.
4. Verify that no unexpected error codes appear.

Security: If security risks exist, take suitable measures to prevent them.

User accessibility: Restrict access to the ISD 520/DSD 520 servo drives and other system components if access to them could result in safety risks.

9 Diagnostics

9.1 Faults

If faults occur during operation, check:

- The indicator lights (LEDs) on the servo drives for general problems relating to communication or device status.
- The indicator lights (LEDs) on the PSM 510 and DAM 510 for general problems with communication, auxiliary supply, or STO voltage.
- The error codes.

The error codes can be read using the VLT® Servo Toolbox software, the LCP, or the PLC. The LCP only shows faults relating to the device it is connected to.

NOTICE

- If the fault cannot be eliminated by 1 of the measures listed in the troubleshooting tables, notify Danfoss Service.

Have the following information available to enable Danfoss to provide help quickly and effectively:

- Type number
- Error code
- Firmware version
- System setup (for example, number of servo drives, system modules, and lines).
- System status when the fault occurred.
- Ambient conditions.

9.2 Troubleshooting

9.2.1 Troubleshooting for the Servo Drives (ISD 520/DSD 520)

9.2.1.1 Drive not Running/Starting Slowly

Possible cause

- Bearing wear.
- Incorrect parameter settings.
- Incorrect control loop parameters.
- Incorrect torque settings.
- Mechanical brake still engaged.

Troubleshooting

- Check the bearings and the shaft.
- Check the parameter settings.
- For ISD 520 check the mechanical brake, for DSD 520 check the mechanical brake parameters.

9.2.1.2 Drive Hums and Draws High Current

Possible cause

- ISD 520: Drive defective.
- DSD 520:
 - Incorrect motor parameter settings.
 - Feedback offset adjustment procedure not executed.

- Incorrect wiring of motor phases (U, V, W are swapped or not connected).

Troubleshooting

- ISD 520: Contact Danfoss.
- DSD 520:
 - Check the motor parameters settings.
 - Perform the commissioning procedure *Feedback offset adjustment*.

9.2.1.3 Drive Stops Suddenly and Restart is not Possible

Possible cause

- No drive communication.
- Servo drive in error mode.

Troubleshooting

- Check the fieldbus connection and the indicator lights (LEDs) on the servo drive.

9.2.1.4 Motor Rotating in Wrong Direction

Possible cause

- Mirror mode activated.

Troubleshooting

- Check the parameter settings.

9.2.1.5 Motor not Generating Expected Torque

Possible cause

- ISD 520:
 - Drive defective.
- DSD 520:
 - Incorrect motor parameter settings.
 - Feedback offset adjustment procedure not executed.
 - Partial (incorrect) opening of mechanical brake.

Troubleshooting

- ISD 520: Contact Danfoss.
- DSD 520:
 - Check the motor parameter settings.
 - Perform the commissioning procedure *Feedback offset adjustment*.

9.2.1.6 Drive Screaming

Possible cause

- Incorrect calibration.
- Faulty current measurement.
- Incorrect control loop parameters.

Troubleshooting

- Check the parameter settings.
- Contact Danfoss.

9.2.1.7 Uneven Running

Possible cause

- Defective bearing.

Troubleshooting

- Check the shaft.

9.2.1.8 Vibration

Possible cause

- Defective bearing.
- Incorrect control loop parameters.

Troubleshooting

- Check the shaft.
- Check the parameter settings.

9.2.1.9 Unusual Running Noises

Possible cause

- Defective bearing.
- Defects on connected mechanics.
- Incorrect control loop parameters.

Troubleshooting

- Check the shaft.
- Check for loose mechanical components on the connected mechanics.
- Check the parameter settings.

9.2.1.10 Drive Speed Drops Sharply under Load

Possible cause

- Drive is running at current limit.
- Drive is running with incorrect parameters.
- Speed control loop bandwidth is too low.

Troubleshooting

- Check the application.
- Check the parameter settings.
- Modify the speed control loop parameters.

9.2.1.11 Brake not Releasing

Possible cause

- Defective brake control.
- Incorrect mechanical brake parameters.

Troubleshooting

- Check the parameter settings.
- Contact Danfoss.

9.2.1.12 Holding Brake not Holding the Servo Drive

Possible cause

- Mechanical brake defective.
- Shaft load exceeds the holding torque of the brake.

Troubleshooting

- Contact Danfoss.

9.2.1.13 Delayed Brake Engagement

Possible cause

- Software error.
- Issues with auxiliary voltage.

Troubleshooting

- Contact Danfoss.
- Ensure the U_{AUX} is 48 V if the ISD 520 has the optional mechanical brake.

9.2.1.14 Noises when Power-Off Brake is Engaged

Possible cause

- Mechanical brake damaged.

Troubleshooting

- Contact Danfoss.

9.2.1.15 Indicator Lights (LEDs) not Lighting Up

Possible cause

- No power supply.

Troubleshooting

- Check the power supply.

9.2.1.16 Drive Protection Trips Immediately

Possible cause

- Short circuit.
- Incorrect control loop parameters.

Troubleshooting

- Check the parameter settings.
- Check the wiring.
- Contact Danfoss.

9.2 Troubleshooting for the Servo System

9.2.2.1 LCP Display is Dark/Not Functioning

This fault applies to the ISD 520/DSD 520 servo drives, PSM 510, DAM 510, and ACM 510.

Possible causes and troubleshooting

Table 48: Possible Causes and Troubleshooting

| Possible cause | Possible solution |
|--|--|
| Missing input power. | Check the input power source. |
| Missing or open fuses, or circuit breaker tripped. | Check the fuses and circuit breaker. |
| No power to the LCP. | <ul style="list-style-type: none"> • Check the LCP cable for proper connection or damage. • Replace any faulty LCP or connection cables. |
| Incorrect contrast setting. | Press [Status] + [▲]/[▼] to adjust the contrast. |
| Display is defective. | Replace the faulty LCP or connection cable. |

9.2.2.2 Open Power Fuses or Circuit Breaker Trip

This fault applies to the PSM 510 and DAM 510.

Possible causes

- Phase-to-phase short.
- Short on backlink.
- Short on hybrid cable.
- Short on EXM 510 connector or cable.
- Short on ISD 520/DSD 520 connector.

Troubleshooting

- Check the cabling.
- Check for loose connections.

9.2.2.3 DC-link Voltage Too Low (Error 0x3220/0x104)

This fault applies to all system modules.

Possible cause

- Incorrect mains input supply.

Troubleshooting

- Check that the supply voltage matches the allowed specification.

9.2.2.4 Current Overload Trip (Error 0x2396/0x15C)

This fault applies to the PSM 510 and the DAM 510.

Possible causes

- The sum of the servo drive current exceeds the maximum rating of the DAM 510.
- The sum of the system modules' current exceeds the maximum rating of the PSM 510.
- Short on backlink.

Troubleshooting

- Check the servo drive current consumption.
- Avoid simultaneous acceleration of all servo drives.
- Decrease the acceleration value.

9.2.2.5 High Cont. Power Overload (Error 0x2313/0x161)

This fault applies to the PSM 510.

Possible causes

- The PSM 510 was operating at over 140% of the nominal power rating for too long.

Troubleshooting

- Check the current consumption.

9.2.2.6 Continuous Power Overload (Error 0x2314/0x162)

This fault applies to the PSM 510.

Possible causes

- The PSM 510 was operating at 100–140% of the nominal power rating for too long.

Troubleshooting

- Check the current consumption.

9.2.2.7 AUX Overcurrent (Error 0x2391/0x125)

This fault applies to the DAM 510.

Possible causes

- The servo drives are consuming more power on the U_{AUX} line than allowed.

Troubleshooting

- Check the number of attached servo drives with the shell diagrams in the *VLT® Servo Drive System ISD 520, DSD 520, MSD 520 (VLT® FlexMotion™) Design Guide*.
- Avoid simultaneous lifting of the servo drive brakes.

9.2.2.8 AUX Overvoltage (Error 0x3292/0x133)

This fault applies to the DAM 510.

Possible causes

- Incorrect U_{AUX} supply.

Troubleshooting

- Check that the supply matches the auxiliary supply requirements.

9.2.2.9 AUX Undervoltage (Error 0x3294/0x135)

This fault applies to the PSM 510, DAM 510, and ACM 510.

Possible causes

- Incorrect U_{AUX} supply.
- Incorrect current dimensioning of the supply equipment.

Troubleshooting

- Check that the supply matches the auxiliary supply requirements.
- Check that the output power of the supply is sufficient.

9.2.2.10 Mains Phase Loss (Error 0x3130/0x12F)

This fault applies to the PSM 510.

Possible causes

- A phase is missing on the supply side.
- The voltage imbalance is too high.

Troubleshooting

- Check the supply voltages and supply currents to the device.

9.2.2.11 Generic Application Error (Error 0x1000/0x100)

This error is valid for PSM 510, DAM 510, ACM 510, and ISD 520/DSD 520.

Possible causes

- A generic error has occurred in the application.

Troubleshooting

- Contact Danfoss.

9.2.2.12 Grounding Fault

This fault applies to the PSM 510, DAM 510, and ACM 510.

Possible causes

- Grounding fault.
- When 2 PSM 510 modules are mounted in parallel and the maximum delay time for power-up is exceeded.

Troubleshooting

- Check for proper grounding and loose connections.
- Check the hybrid cables for short circuits or leakage currents.
- Check the EXM 510 connection and cable.

9.2.2.13 Brake Resistor Error

This fault applies to the PSM 510.

Possible causes

- Faulty brake resistor.
- Internal/external brake resistor not connected.

Troubleshooting

- Remove the power to the device, wait for the discharge time to elapse, then replace the brake resistor.

9.2.2.14 Brake Chopper Error

This fault applies to the PSM 510.

Possible causes

- Faulty brake chopper.
- Brake chopper power exceeds the power cycle limit.
- Incorrect parameterization.

Troubleshooting

- Check the parameterization of the brake chopper.
- Check the brake chopper connection.
- Measure the resistance of the brake chopper and compare it with the parameter settings.

9.2.2.15 Internal Fan Error

This fault applies to PSM 510.

Possible causes

- Fan is not mounted.
- Fan is blocked.

Troubleshooting

- Check if the fan is blocked.
- Check the fan cables for proper connection or damage.

9.3 Error Codes for ISD 520/DSD 520 Servo System

9.3.1 No error (0x0000 / 0x0)

This error code is valid for PSM 510, DAM 510, ACM 510, and ISD 520/DSD 520.

Table 49: No error (0x0000 / 0x0)

| Code | PROFINET® code | Name | Severity (warning/error/trip lock) | Description | LCP name |
|--------|----------------|----------|------------------------------------|-------------|----------|
| 0x0000 | 0x0 | No error | Error | No error. | – |

9.3.2 Generic application error (0x1000 / 0x100)

This error is valid for PSM 510, DAM 510, ACM 510, and ISD 520/DSD 520.

Table 50: Generic err (0x1000 / 0x100)

| Code | PROFINET® code | Name | Severity (warning/error/trip lock) | Description | LCP name |
|--------|----------------|---------------------------|------------------------------------|----------------------------|-------------|
| 0x1000 | 0x100 | Generic application error | Error | Generic application error. | generic err |

9.3.3 Overcurrent Trip (0x2310 / 0x101)

Table 51: Overcurr out (0x2310 / 0x101)

| Code | PROFINET® code | Name | Severity (warning/error/trip lock) | Description | LCP name |
|--------|----------------|------------------|------------------------------------|-----------------------------|---------------|
| 0x2310 | 0x101 | Overcurrent trip | Error | Overcurrent trip on output. | overcurr trip |

9.3.4 High cont. current overload (0x2311 / 0x15F)

Table 52: High cont. current overload (0x2311 / 0x15F)

| Code | PROFINET® code | Name | Severity (warning/error/trip lock) | Description | LCP name |
|--------|----------------|-----------------------------|------------------------------------|---|----------------|
| 0x2311 | 0x15F | High cont. current overload | Error | High continuous current overload error. | high curr ovld |

9.3.5 Continuous current overload (0x2312 / 0x160)

This error is valid for DAM 510 and ISD 520/DSD 520.

Table 53: Continuous current overload (0x2312 / 0x160)

| Code | PROFINET® code | Name | Severity (warning/error/trip lock) | Description | LCP name |
|--------|----------------|-----------------------------|------------------------------------|------------------------------------|----------------|
| 0x2312 | 0x160 | Continuous current overload | Error | Continuous current overload error. | cont curr ovld |

9.3.6 High cont. power overload (0x2313 / 0x161)

This error is valid for PSM 510.

Table 54: High cont. power overload (0x2313 / 0x161)

| Code | PROFINET® code | Name | Severity (warning/error/trip lock) | Description | LCP name |
|--------|----------------|---------------------------|------------------------------------|---------------------------------------|---------------|
| 0x2313 | 0x161 | High cont. power overload | Warning, error | High continuous power overload error. | high pwr ovld |

9.3.7 Continuous power overload (0x2314 / 0x162)

This error is valid for PSM 510.

Table 55: Continuous power overload (0x2314 / 0x162)

| Code | PROFINET® code | Name | Severity (warning/error/trip lock) | Description | LCP name |
|--------|----------------|---------------------------|------------------------------------|----------------------------------|---------------|
| 0x2314 | 0x162 | Continuous power overload | Warning, error | Continuous power overload error. | cont pwr ovld |

9.3.8 Overcurrent short circuit (0x2320 / 0x163)

This error is valid for PSM 510 and DAM 510.

Table 56: Overcurrent short circuit (0x2320 / 0x163)

| Code | PROFINET® code | Name | Severity (warning/error/trip lock) | Description | LCP name |
|--------|----------------|---------------------------|------------------------------------|----------------------------------|-----------------|
| 0x2320 | 0x163 | Overcurrent short circuit | Trip lock | Overcurrent short circuit error. | over curr short |

9.3.9 Ground fault (0x2330 / 0x151)

This error is valid for PSM 510, DAM 510, and ISD 520/DSD 520.

Table 57: Ground fault (0x2330 / 0x151)

| Code | PROFINET® code | Name | Severity (warning/error/trip lock) | Description | LCP name |
|--------|----------------|--------------|------------------------------------|---|--------------|
| 0x2330 | 0x151 | Ground fault | Warning, error | Discharge from output phases to ground. | ground fault |

9.3.10 AUX overcurrent (0x2391 / 0x125)

This error is valid for DAM 510.

Table 58: AUX overcurr (0x2391 / 0x125)

| Code | PROFINET® code | Name | Severity (warning/error/trip lock) | Description | LCP name |
|--------|----------------|-----------------|------------------------------------|--|--------------|
| 0x2391 | 0x125 | AUX overcurrent | Error | Current on the AUX line has reached the overcurrent limit. | AUX overcurr |

9.3.11 AUX user limit current (0x2393 / 0x127)

This error is valid for DAM 510.

Table 59: AUX user limit current (0x2393 / 0x127)

| Code | PROFINET® code | Name | Severity (warning/error/trip lock) | Description | LCP name |
|--------|----------------|------------------------|------------------------------------|---|----------------|
| 0x2393 | 0x127 | AUX user limit current | Error | Current on the AUX line has reached the user-defined limit for fault. | AUX curr limit |

9.3.12 AUX user limit current warning (0x2394 / 0x128)

This error is valid for PSM 510 and DAM 510.

Table 60: AUX user limit current warning (0x2394 / 0x128)

| Code | PROFINET® code | Name | Severity (warning/error/trip lock) | Description | LCP name |
|--------|----------------|--------------------------------|------------------------------------|---|---------------|
| 0x2394 | 0x128 | AUX user limit current warning | Warning | Current on the AUX line has reached the user-defined limit for warning. | AUX curr warn |

9.3.13 AUX supply failure (0x2395 / 0x129)

This error is valid for DAM 510.

Table 61: AUX supply failure (0x2395 / 0x129)

| Code | PROFINET® code | Name | Severity (warning/error/trip lock) | Description | LCP name |
|--------|----------------|--------------------|------------------------------------|--|-----------------|
| 0x2395 | 0x129 | AUX supply failure | Error | AUX supply failure indicated by hardware circuit | AUX supply fail |

9.3.14 Current overload trip (0x2396 / 0x15C)

This error is valid for DAM 510 and ISD 520/DSD 520.

Table 62: Current overload trip (0x2396 / 0x15C)

| Code | PROFINET® code | Name | Severity (warning/error/trip lock) | Description | LCP name |
|--------|----------------|-----------------------|------------------------------------|------------------------------|----------------|
| 0x2396 | 0x15C | Current overload trip | Error | Current overload trip error. | curr ovld trip |

9.3.15 Power overload trip (0x2397 / 0x12B)

This error is valid for PSM 510.

Table 63: Power overload trip (0x2397 / 0x12B)

| Code | PROFINET® code | Name | Severity (warning/error/trip lock) | Description | LCP name |
|--------|----------------|---------------------|------------------------------------|----------------------------|---------------|
| 0x2397 | 0x12B | Power overload trip | Error | Power overload trip error. | pwr ovld trip |

9.3.16 Thermal overload motor (0x239B / 0x102)

This error is valid for ISD 520/DSD 520.

Table 64: Thermal overload motor (0x239B / 0x102)

| Code | PROFINET® code | Name | Severity (warning/error/trip lock) | Description | LCP name |
|--------|----------------|------------------------|------------------------------------|-------------------------------|------------------|
| 0x239B | 0x102 | Thermal overload motor | Warning, error | Thermal overload motor error. | therm ovld motor |

9.3.17 DC Short Circuit (0x239C / 0x16F)

This error is valid for ISD 520/DSD 520.

Table 65: Thermal overload motor (0x239C / 0x16F)

| Code | PROFINET® code | Name | Severity (warning/error/trip lock) | Description | LCP name |
|--------|----------------|------------------|------------------------------------|---------------------------|----------|
| 0x239C | 0x16F | DC short circuit | Error | Short circuit on DC link. | DC short |

9.3.18 Overcurrent motor (0x239D / 0x170)

This error applies to ISD 520/DSD 520.

Table 66: Overcurrent motor (0x239D / 0x170)

| Code | PROFINET® code | Name | Severity (warning/error/trip lock) | Description | LCP name |
|--------|----------------|-------------------|------------------------------------|--|----------------|
| 0x239D | 0x170 | Overcurrent motor | Error | Motor overcurrent fault. The threshold value defined by object 0x2395 is exceeded. | overcurr motor |

9.3.19 Mains phase loss (0x3130 / 0x12F)

This error is valid for PSM 510.

Table 67: Mains phase loss (0x3130 / 0x12F)

| Code | PROFINET® code | Name | Severity (warning/error/trip lock) | Description | LCP name |
|--------|----------------|------------------|------------------------------------|--|------------|
| 0x3130 | 0x12F | Mains phase loss | Error | Mains phase loss detected. This occurs when a phase on mains is missing, or when the mains is imbalanced. | phase loss |

9.3.20 DC link overvoltage (0x3210 / 0x103)

This error is valid for PSM 510, DAM 510, ACM 510, and ISD 520/DSD 520.

Table 68: DC link overvoltage (0x3210 / 0x103)

| Code | PROFINET® code | Name | Severity (warning/error/trip lock) | Description | LCP name |
|--------|----------------|---------------------|------------------------------------|--------------------------------|--------------|
| 0x3210 | 0x103 | DC link overvoltage | Error | DC-link voltage exceeds limit. | UDC overvolt |

9.3.21 DC link undervoltage (0x3220 / 0x104)

This error is valid for PSM 510, DAM 510, ACM 510, and ISD 520/DSD 520.

Table 69: DC link undervoltage (0x3220 / 0x104)

| Code | PROFINET® code | Name | Severity (warning/error/trip lock) | Description | LCP name |
|--------|----------------|----------------------|------------------------------------|---|---------------|
| 0x3220 | 0x104 | DC link undervoltage | Error | DC-link voltage below limit in <i>Operation enabled</i> state | UDC undervolt |

9.3.22 DC link charging error (0x3230 / 0x152)

This error is valid for PSM 510, DAM 510, ACM 510, and ISD 520/DSD 520.

Table 70: DC link charging error (0x3230 / 0x152)

| Code | PROFINET® code | Name | Severity (warning/error/trip lock) | Description | LCP name |
|--------|----------------|------------------------|------------------------------------|---|--------------|
| 0x3230 | 0x152 | DC link charging error | Error | The maximum time limit to charge the DC link has been exceeded. | UDC charging |

9.3.23 DC Link unbalanced (0x3280 / 0x153)

Table 71: DC Link unbalanced (0x3280 / 0x153)

| Code | PROFINET® code | Name | Severity (warning/error/trip lock) | Description | LCP name |
|--------|----------------|--------------------|------------------------------------|---|---------------|
| 0x3280 | 0x153 | DC Link unbalanced | Trip lock | DC-link voltage is unbalanced. This fault indicates an internal malfunction of the DC link. | UDC unbalance |

9.3.24 UAUX high voltage (0x3291 / 0x132)

This error is valid for PSM 510, DAM 510, and ACM 510.

Table 72: UAUX high voltage (0x3291 / 0x132)

| Code | PROFINET® code | Name | Severity (warning/error/trip lock) | Description | LCP name |
|--------|----------------|-------------------------------|------------------------------------|---------------------------------------|-----------------------|
| 0x3291 | 0x132 | U _{AUX} high voltage | Warning | U _{AUX} above warning limit. | UAUX high volt limit. |

9.3.25 UAUX overvoltage (0x3292 / 0x133)

This error is valid for DAM 510.

Table 73: UAUX overvoltage (0x3292 / 0x133)

| Code | PROFINET® code | Name | Severity (warning/error/trip lock) | Description | LCP name |
|--------|----------------|------------------------------|------------------------------------|---|--------------------------|
| 0x3292 | 0x133 | U _{AUX} overvoltage | Error | U _{AUX} above overvoltage limit. | UAUX overvolt age limit. |

9.3.26 UAUX low voltage (0x3293 / 0x134)

This error is valid for PSM 510, DAM 510, and ACM 510.

Table 74: UAUX low voltage (0x3293 / 0x134)

| Code | PROFINET® code | Name | Severity (warning/error/trip lock) | Description | LCP name |
|--------|----------------|------------------------------|------------------------------------|---------------------------------------|----------------------|
| 0x3293 | 0x134 | U _{AUX} low voltage | Warning | U _{AUX} below warning limit. | UAUX low volt limit. |

9.3.27 UAUX undervoltage (0x3294 / 0x135)

This error is valid for PSM 510, DAM 510, and ACM 510.

Table 75: UAUX undervoltage (0x3294 / 0x135)

| Code | PROFINET® code | Name | Severity (warning/error/trip lock) | Description | LCP name |
|--------|----------------|-------------------------------|------------------------------------|--|----------------|
| 0x3294 | 0x135 | U _{AUX} undervoltage | Error | U _{AUX} below undervoltage limit. | UAUX undervolt |

9.3.28 DC link high voltage (0x3295 / 0x136)

This error is valid for PSM 510, DAM 510, and ACM 510.

Table 76: DC link high voltage (0x3295 / 0x136)

| Code | PROFINET® code | Name | Severity (warning/error/trip lock) | Description | LCP name |
|--------|----------------|----------------------|------------------------------------|--|---------------|
| 0x3295 | 0x136 | DC link high voltage | Warning | The DC-link voltage is higher than the high-voltage warning limit. | UDC high volt |

9.3.29 DC link low voltage (0x3296 / 0x137)

This error is valid for PSM 510, DAM 510, and ACM 510.

Table 77: DC link low voltage (0x3296 / 0x137)

| Code | PROFINET® code | Name | Severity (warning/error/trip lock) | Description | LCP name |
|--------|----------------|---------------------|------------------------------------|--|--------------|
| 0x3296 | 0x137 | DC link low voltage | Warning | The DC-link voltage is lower than the low voltage warning limit. | UDC low volt |

9.3.30 UAUX charging error (0x3297 / 0x154)

This error is valid for DAM 510.

Table 78: UAUX charging error (0x3297 / 0x154)

| Code | PROFINET® code | Name | Severity (warning/error/trip lock) | Description | LCP name |
|--------|----------------|---------------------------------|------------------------------------|--|----------------|
| 0x3297 | 0x154 | U _{AUX} charging error | Error | Load error when U _{AUX} is charging. The maximum time limit to charge the AUX line has been exceeded. | UAUX charg err |

9.3.31 DC link shutdown error (0x3298 / 0x165)

This error is valid for DAM 510.

Table 79: DC link shutdown error (0x3298 / 0x165)

| Code | PROFINET® code | Name | Severity (warning/error/trip lock) | Description | LCP name |
|--------|----------------|------------------------|------------------------------------|--------------------------------------|-----------------|
| 0x3298 | 0x165 | DC link shutdown error | Error | Error when UDC is in shutdown phase. | UDC shutdwn err |

9.3.32 UAUX shutdown error (0x3299 / 0x155)

This error is valid for DAM 510.

Table 80: UAUX shutdown error (0x3299 / 0x155)

| Code | PROFINET® code | Name | Severity (warning/error/trip lock) | Description | LCP name |
|--------|----------------|---------------------------------|------------------------------------|---|-----------------|
| 0x3299 | 0x155 | U _{AUX} shutdown error | Error | Error when U _{AUX} is in shutdown phase. | UAUX shtdwn err |

9.3.33 UAUX undervoltage hardware (0x329A / 0x156)

This error is valid for PSM 510, DAM 510, and ACM 510.

Table 81: UAUX undervoltage hardware (0x329A / 0x156)

| Code | PROFINET® code | Name | Severity (warning/error/trip lock) | Description | LCP name |
|--------|----------------|--|------------------------------------|---|-----------------|
| 0x329A | 0x156 | U _{AUX} undervoltage hardware | Error | U _{AUX} undervoltage detected by hardware circuit. | AUX undervol HW |

9.3.34 Automated fault reset failure (0x329B / 0x168)

This error is valid for PSM 510, DAM 510, and ACM 510.

Table 82: Automated fault reset failure (0x329B / 0x168)

| Code | PROFINET® code | Name | Severity (warning/error/trip lock) | Description | LCP name |
|--------|----------------|-------------------------------|------------------------------------|--|----------------|
| 0x329B | 0x168 | Automated fault reset failure | Trip lock | Too many auto fault resets have been executed in the intended time interval. | autoreset fail |

9.3.35 Device overtemperature (0x4210 / 0x157)

This error is valid for PSM 510, DAM 510, and ACM 510.

Table 83: Device overtemperature (0x4210 / 0x157)

| Code | PROFINET® code | Name | Severity (warning/error/trip lock) | Description | LCP name |
|--------|----------------|------------------------|------------------------------------|--|-----------------|
| 0x4210 | 0x157 | Device overtemperature | Warning, error | Triggered when the maximum temperature of the main device component is exceeded. PSM 510: Thyristor rectifier module. DAM 510: Maximum temperature of both high side and low side IGBTs. | overtemp device |

9.3.36 Device under temperature (0x4220 / 0x138)

This error is valid for PSM 510, DAM 510, and ACM 510.

Table 84: Device under temperature (0x4220 / 0x138)

| Code | PROFINET® code | Name | Severity (warning/error/trip lock) | Description | LCP name |
|--------|----------------|--------------------------|------------------------------------|------------------------------------|------------------|
| 0x4220 | 0x138 | Device under temperature | Error | The device is too cold to operate. | undertemp device |

9.3.37 Overtemperature: Control card (0x4291 / 0x106)

This error is valid for PSM 510, DAM 510, ACM 510, and ISD 520/DSD 520.

Table 85: Overtemperature: Control card (0x4291 / 0x106)

| Code | PROFINET® code | Name | Severity (warning/error/trip lock) | Description | LCP name |
|--------|----------------|-------------------------------|------------------------------------|---|-------------|
| 0x4291 | 0x106 | Overtemperature: Control card | Error | Maximum temperature of the control card exceeded. | overtemp CC |

9.3.38 Overtemperature: Power card (0x4292 / 0x107)

This error is valid for PSM 510, DAM 510, and ACM 510.

Table 86: Overtemperature: Power card (0x4292 / 0x107)

| Code | PROFINET® code | Name | Severity (warning/error/trip lock) | Description | LCP name |
|--------|----------------|-----------------------------|------------------------------------|---|-------------|
| 0x4292 | 0x107 | Overtemperature: Power card | Warning, error | Maximum temperature of power card exceeded. | overtemp PC |

9.3.39 Inrush overtemperature DC link (0x4293 / 013C)

This error is valid for PSM 510, DAM 510, and ACM 510.

Table 87: Inrush overtemperature DC link (0x4293 / 0x13C)

| Code | PROFINET® code | Name | Severity (warning/error/trip lock) | Description | LCP name |
|--------|----------------|---------------------------------|------------------------------------|--|------------|
| 0x4293 | 0x13C | Inrush overtemperature: DC link | Error | Inrush fault. Too many transitions into state <i>Operation enabled</i> in a short time period. | UDC inrush |

9.3.40 Inrush overtemperature AUX line (0x4294 / 0x13D)

This error is valid for DAM 510.

Table 88: Inrush overtemperature AUX line (0x4294 / 0x13D)

| Code | PROFINET® code | Name | Severity (warning/error/trip lock) | Description | LCP name |
|--------|----------------|---------------------------------|------------------------------------|---|-------------|
| 0x4294 | 0x13D | Inrush overtemperature AUX line | Error | Inrush fault. Too many power-ups of the AUX voltage have occurred within a short time period. | UAUX inrush |

9.3.41 Overtemperature: Motor (0x4310 / 0x108)

This error is valid for ISD 520/DSD 520.

Table 89: Overtemperature: Motor (0x4310 / 0x108)

| Code | PROFINET® code | Name | Severity (warning/error/trip lock) | Description | LCP name |
|--------|----------------|------------------------|------------------------------------|---------------------------|----------------|
| 0x4310 | 0x108 | Overtemperature: Motor | Error | Overtemperature on motor. | overtemp motor |

9.3.42 AUX undervoltage (0x5112 / 0x135)

This error is valid for ISD 520/DSD 520.

Table 90: AUX undervoltage (0x5112 / 0x135)

| Code | PROFINET® code | Name | Severity (warning/error/trip lock) | Description | LCP name |
|--------|----------------|------------------|------------------------------------|-------------------------------------|----------------|
| 0x5112 | 0x135 | AUX undervoltage | Error | U_{AUX} below undervoltage limit. | UAUX undervolt |

9.3.43 Charge switch failure voltage (0x5121 / 0x158)

This error is valid for PSM 510.

Table 91: Charge switch failure voltage (0x5121 / 0x158)

| Code | PROFINET® code | Name | Severity (warning/error/trip lock) | Description | LCP name |
|--------|----------------|-------------------------------|------------------------------------|---|-----------------|
| 0x5121 | 0x158 | Charge switch failure voltage | Trip lock | Indicates a malfunction of the internal charge circuit. | Chg switch fail |

9.3.44 Failure on output phase U (0x5411 / 0x123)

This error is valid for ISD 520/DSD 520

Table 92: Failure on output phase U (0x5411 / 0x123)

| Code | PROFINET® code | Name | Severity (warning/error/trip lock) | Description | LCP name |
|--------|----------------|---------------------------|------------------------------------|----------------------------|----------------|
| 0x5411 | 0x123 | Failure on output phase U | Trip lock | Failure on output phase U. | output phase U |

9.3.45 Failure on output phase V (0x5412 / 0x124)

This error is valid for ISD 520/DSD 520

Table 93: Failure on output phase V (0x5412 / 0x124)

| Code | PROFINET® code | Name | Severity (warning/error/trip lock) | Description | LCP name |
|--------|----------------|---------------------------|------------------------------------|---|----------------|
| 0x5412 | 0x124 | Failure on output phase V | Trip lock | Current offset on output phase V outside limit. | output phase V |

9.3.46 Failure on output phase W (0x5413 / 0x125)

This error is valid for ISD 520/DSD 520

Table 94: Failure on output phase W (0x5413 / 0x125)

| Code | PROFINET® code | Name | Severity (warning/error/trip lock) | Description | LCP name |
|--------|----------------|---------------------------|------------------------------------|---|----------------|
| 0x5413 | 0x125 | Failure on output phase W | Trip lock | Current offset on output phase W outside limit. | output phase W |

9.3.47 EE Checksum Error (parameter missing) (0x5530 / 0x10A)

This error is valid for ISD 520/DSD 520.

Table 95: EE Checksum Error (parameter missing) (0x5530 / 0x10A)

| Code | PROFINET® code | Name | Severity (warning/error/trip lock) | Description | LCP name |
|--------|----------------|---------------------------------------|------------------------------------|---|-----------|
| 0x5530 | 0x10A | EE Checksum Error (parameter missing) | Trip lock | EEPROM checksum error or missing device parameter. Contact Danfoss. | eprom err |

9.3.48 Parameter error (0x6320 / 0x10B)

This error is valid for PSM 510, DAM 510, ACM 510, and ISD 520/DSD 520.

Table 96: Param err (0x6320 / 0x10B)

| Code | PROFINET® code | Name | Severity (warning/error/trip lock) | Description | LCP name |
|--------|----------------|-----------------|------------------------------------|-----------------------------------|-----------|
| 0x6320 | 0x10B | Parameter error | Trip lock | A parameter has an invalid value. | param err |

9.3.49 Parameter Configuration: Previous configuration restored (0x6321 / 0x171)

This error is valid for ISD 520/DSD 520.

Table 97: Parameter Configuration: Previous configuration restored (0x6321 / 0x171)

| Code | PROFINET® code | Name | Severity (warning/error/trip lock) | Description | LCP name |
|--------|----------------|--|------------------------------------|---|----------------------|
| 0x6321 | 0x171 | Parameter Configuration: Previous configuration restored | Error | The previous stored configuration has been reloaded because something went wrong with the latest configuration. | prev config restored |

9.3.50 Parameter Configuration: Power cycle needed (0x6322 / 0x172)

This error is valid for ISD 520/DSD 520.

Table 98: Parameter Configuration: Power cycle needed (0x6322 / 0x172)

| Code | PROFINET® code | Name | Severity (warning/error/trip lock) | Description | LCP name |
|--------|----------------|---|------------------------------------|--|-------------|
| 0x6322 | 0x172 | Parameter Configuration: Power cycle needed | Warning, error | Power cycle or reset is needed to apply the new configuration. | power cycle |

9.3.51 Parameter Configuration: Wrong thermal sensor configuration (0x6323 / 0x0173)

This error is valid for ISD 520/DSD 520.

Table 99: Parameter Configuration: Wrong thermal sensor configuration (0x6323 / 0x173)

| Code | PROFINET® code | Name | Severity (warning/error/trip lock) | Description | LCP name |
|--------|----------------|---|------------------------------------|---|--------------------|
| 0x6323 | 0x173 | Parameter Configuration: Wrong thermal sensor configuration | Error | Wrong configuration of parameters 0x2350 and 0x2361. At least one of them must be set to <i>no sensor</i> . | wrong thermal sens |

9.3.52 Conf par ver (0x6382 / 0x15D)

This error is valid for PSM 510, DAM 510, ACM 510, and ISD 520/DSD 520.

Table 100: Configuration parameters version error (0x6382 / 0x15D)

| Code | PROFINET® code | Name | Severity (warning/error/trip lock) | Description | LCP name |
|--------|----------------|--|------------------------------------|--|--------------|
| 0x6382 | 0x15D | Configuration parameters version error | Trip lock | Configuration parameter set version mismatch: parameter set is not valid for this device. Check the configuration file sent to the device and replace it. If the error persists, contact Danfoss. | conf par ver |

9.3.53 Configuration parameters limits error (0x6383 / 0x164)

This error is valid for PSM 510, DAM 510, and ACM 510.

Table 101: Configuration parameters limits error (0x6383 / 0x164)

| Code | PROFINET® code | Name | Severity (warning/error/trip lock) | Description | LCP name |
|--------|----------------|---------------------------------------|------------------------------------|---|--------------|
| 0x6383 | 0x164 | Configuration parameters limits error | Trip lock | ≥1 parameter in the configuration parameter set is out of limits. | conf par lim |

9.3.54 Power EEprom configuration error (0x6384 / 0x166)

This error is valid for PSM 510, DAM 510, ACM 510, and ISD 520/DSD 520.

Table 102: Power EEprom configuration error (0x6384 / 0x166)

| Code | PROFINET® code | Name | Severity (warning/error/trip lock) | Description | LCP name |
|--------|----------------|----------------------------------|------------------------------------|--|-----------------|
| 0x6384 | 0x166 | Power EEprom configuration error | Trip lock | The power device EEprom is corrupt or incompatible with this control board. Contact Danfoss. | conf par EEPROM |

9.3.55 Brake chopper failure (0x7111 / 0x141)

This error is valid for PSM 510.

Table 103: Brake chopper failure (0x7111 / 0x141)

| Code | PROFINET® code | Name | Severity (warning/error/trip lock) | Description | LCP name |
|--------|----------------|-----------------------|------------------------------------|---|---------------|
| 0x7111 | 0x141 | Brake chopper failure | Warning, error | The brake chopper is monitored during operation. A brake failure has been detected by the brake check function. | brake ch fail |

9.3.56 Brake chopper overcurrent (0x7112 / 0x167)

This error is valid for PSM 510.

Table 104: Brake chopper overcurrent (0x7112 / 0x167)

| Code | PROFINET® code | Name | Severity (warning/error/trip lock) | Description | LCP name |
|--------|----------------|---------------------------|------------------------------------|--|-------------------|
| 0x7112 | 0x167 | Brake chopper overcurrent | Trip lock | The brake chopper current exceeds the limit. | brake ch overcurr |

9.3.57 Brake chopper module overload (0x7181 / 0x142)

This error is valid for PSM 510.

Table 105: Brake resistor maximum power limit (0x7181 / 0x142)

| Code | PROFINET® code | Name | Severity (warning/error/trip lock) | Description | LCP name |
|--------|----------------|-------------------------------|------------------------------------|--|----------|
| 0x7181 | 0x142 | Brake chopper module overload | Warning, error | The power load of the brake chopper is monitored during operation. This error appears when the maximum power limit of the brake chopper module is reached. | mod ovl |

9.3.58 External brake chopper overload (0x7182 / 0x143)

This error is valid for PSM 510.

Table 106: External brake chopper overload (0x7182 / 0x143)

| Code | PROFINET® code | Name | Severity (warning/error/trip lock) | Description | LCP name |
|--------|----------------|---------------------------------|------------------------------------|--|------------------|
| 0x7182 | 0x143 | External brake chopper overload | Warning, error | The power load of the brake chopper is monitored during operation. Depending on the configuration of <i>external brake chopper power monitoring</i> this warning or fault appears when the configured nominal external brake chopper power is reached. | ext brake ch ovl |

9.3.59 Brake mains voltage too high (0x7183 / 0x159)

This error is valid for PSM 510.

Table 107: Brake mains voltage too high (0x7183 / 0x159)

| Code | PROFINET® code | Name | Severity (warning/error/trip lock) | Description | LCP name |
|--------|----------------|------------------------------|------------------------------------|--|--------------------|
| 0x7183 | 0x159 | Brake mains voltage too high | Warning | The mains voltage is too high. Due to this, the brake chopper could be activated continuously depending on the value entered in parameter <i>brake chopper start level</i> . | brake ch high volt |

9.3.60 Internal position sensor error (0x7320 / 0x10C)

This error is valid for ISD 520/DSD 520.

Table 108: Internal position sensor error (0x7320 / 0x10C)

| Code | PROFINET® code | Name | Severity (warning/error/trip lock) | Description | LCP name |
|--------|----------------|--------------------------------|------------------------------------|---|----------------|
| 0x7320 | 0x10C | Internal position sensor error | Trip lock | Absolute position sensor error. If the error persists, contact Danfoss. | int sensor err |

9.3.61 External position sensor error (0x7380 / 0x10D)

This error is valid for DAM 510 and ISD 520/DSD 520.

Table 109: External position sensor error (0x7380 / 0x10D)

| Code | PROFINET® code | Name | Severity (warning/error/trip lock) | Description | LCP name |
|--------|----------------|--------------------------------|------------------------------------|--|----------------|
| 0x7380 | 0x10D | External position sensor error | Error | External encoder data could not be read. | ext sensor err |

9.3.62 Communication error (0x7500 / 0x169)

This error is valid for ISD 520/DSD 520.

Table 110: Communication error (0x7500 / 0x169)

| Code | PROFINET® code | Name | Severity (warning/error/trip lock) | Description | LCP name |
|--------|----------------|---------------------|------------------------------------|---------------------------------------|----------|
| 0x7500 | 0x169 | Communication error | Error | Communication error, connection lost. | comm err |

9.3.63 Following error (0x8611 / 0x10E)

This error is valid for ISD 520/DSD 520.

Table 111: Following error (0x8611 / 0x10E)

| Code | PROFINET® code | Name | Severity (warning/error/trip lock) | Description | LCP name |
|--------|----------------|-----------------|------------------------------------|--|---------------|
| 0x8611 | 0x10E | Following error | Warning, error | A following error has occurred. The error notification feature can be disabled via object 0x2055. | following err |

9.3.64 Homing error on entering homing mode (0x8693 / 0x10F)

This error is valid for ISD 520/DSD 520.

Table 112: Homing error on entering homing mode (0x8693 / 0x10F)

| Code | PROFINET® code | Name | Severity (warning/error/trip lock) | Description | LCP name |
|--------|----------------|--------------------------------------|------------------------------------|---|------------------|
| 0x8693 | 0x10F | Homing error on entering homing mode | Warning | Could not enter homing mode (for example velocity not 0). | Homing mode fail |

9.3.65 Homing error on start homing method (0x8694 / 0x110)

This error is valid for ISD 520/DSD 520.

Table 113: Homing error on start homing method (0x8694 / 0x110)

| Code | PROFINET® code | Name | Severity (warning/error/trip lock) | Description | LCP name |
|--------|----------------|-------------------------------------|------------------------------------|--|--------------------|
| 0x8694 | 0x110 | Homing error on start homing method | Warning | Could not start homing method (for example drive not in standstill). | Homing method fail |

9.3.66 Homing error distance (0x8695 / 0x111)

This error is valid for ISD 520/DSD 520.

Table 114: Homing error distance (0x8695 / 0x111)

| Code | PROFINET® code | Name | Severity (warning/error/trip lock) | Description | LCP name |
|--------|----------------|-----------------------|------------------------------------|--------------------------|-----------------|
| 0x8695 | 0x111 | Homing error distance | Warning | Homing distance reached. | Homing distance |

9.3.67 Mechanical brake failure (0xFF01 / 0x112)

This error is valid for ISD 520/DSD 520.

Table 115: Mechanical brake failure (0xFF01 / 0x112)

| Code | PROFINET® code | Name | Severity (warning/error/trip lock) | Description | LCP name |
|--------|----------------|--------------------------|------------------------------------|---------------------------|-----------------|
| 0xFF01 | 0x112 | Mechanical brake failure | Trip lock | No brake or wire failure. | brake mech fail |

9.3.68 Short circuit in mechanical brake control (0xFF02 / 0x113)

This error is valid for ISD 520/DSD 520.

Table 116: Short circuit in mechanical brake control (0xFF02 / 0x113)

| Code | PROFINET® code | Name | Severity (warning/error/trip lock) | Description | LCP name |
|--------|----------------|---|------------------------------------|---------------------------------|------------------|
| 0xFF02 | 0x113 | Short circuit in mechanical brake control | Trip lock | Short circuit in brake control. | brake mech short |

9.3.69 External interface power failure (0xFF0A / 0x114)

This error is valid for ISD 520/DSD 520.

Table 117: External interface power failure (0xFF0A / 0x114)

| Code | PROFINET® code | Name | Severity (warning/error/trip lock) | Description | LCP name |
|--------|----------------|----------------------------------|------------------------------------|--|-----------------|
| 0xFF0A | 0x114 | External interface power failure | Error | External interface power supply failure. | ext IF pwr fail |

9.3.70 Fan feedback inconsistent (0xFF21 / 0x145)

This error is valid for PSM 510.

Table 118: Fan feedback inconsistent (0xFF21 / 0x145)

| Code | PROFINET® code | Name | Severity (warning/error/trip lock) | Description | LCP name |
|--------|----------------|---------------------------|------------------------------------|--|--------------|
| 0xFF21 | 0x145 | Fan feedback inconsistent | Warning | Internal fan fault. Internal fan not running/mounted. | fan feedback |

9.3.71 Fan lifetime critical (0xFF22 / 0x15A)

This error is valid for PSM 510.

Table 119: Fan lifetime critical (0xFF22 / 0x15A)

| Code | PROFINET® code | Name | Severity (warning/error/trip lock) | Description | LCP name |
|--------|----------------|-----------------------|------------------------------------|--|--------------|
| 0xFF22 | 0x15A | Fan lifetime critical | Warning | The theoretical lifetime of the fan has been exceeded. | fan lifetime |

9.3.72 Timing violation 1 (0xFF60 / 0x115)

This error is valid for ISD 520/DSD 520.

Table 120: Timing violation 1 (0xFF60 / 0x115)

| Code | PROFINET® code | Name | Severity (warning/error/trip lock) | Description | LCP name |
|--------|----------------|--------------------|------------------------------------|------------------|--------------|
| 0xFF60 | 0x115 | Timing violation 1 | Trip lock | Contact Danfoss. | timing err 1 |

9.3.73 Timing violation 2 (0xFF61 / 0x116)

This error is valid for ISD 520/DSD 520.

Table 121: Timing violation 2 (0xFF61 / 0x116)

| Code | PROFINET® code | Name | Severity (warning/error/trip lock) | Description | LCP name |
|--------|----------------|--------------------|------------------------------------|------------------|--------------|
| 0xFF61 | 0x116 | Timing violation 2 | Trip lock | Contact Danfoss. | timing err 2 |

9.3.74 Timing violation 3 (0xFF62 / 0x117)

This error is valid for ISD 520/DSD 520.

Table 122: Timing violation 3 (0xFF62 / 0x117)

| Code | PROFINET® code | Name | Severity (warning/error/trip lock) | Description | LCP name |
|--------|----------------|--------------------|------------------------------------|------------------|--------------|
| 0xFF62 | 0x117 | Timing violation 3 | Trip lock | Contact Danfoss. | timing err 3 |

9.3.75 Timing violation 4 (0xFF63 / 0x118)

This error is valid for ISD 520/DSD 520.

Table 123: Timing violation 4 (0xFF63 / 0x118)

| Code | PROFINET® code | Name | Severity (warning/error/trip lock) | Description | LCP name |
|--------|----------------|--------------------|------------------------------------|------------------|--------------|
| 0xFF63 | 0x118 | Timing violation 4 | Trip lock | Contact Danfoss. | timing err 4 |

9.3.76 Timing violation 5 (0xFF64 / 0x119)

This error is valid for ISD 520/DSD 520.

Table 124: Timing violation 5 (0xFF64 / 0x119)

| Code | PROFINET® code | Name | Severity (warning/error/trip lock) | Description | LCP name |
|--------|----------------|--------------------|------------------------------------|------------------|--------------|
| 0xFF64 | 0x119 | Timing violation 5 | Trip lock | Contact Danfoss. | timing err 5 |

9.3.77 Timing violation 6 (0xFF65 / 0x11A)

This error is valid for ISD 520/DSD 520.

Table 125: Timing violation 6 (0xFF65 / 0x11A)

| Code | PROFINET® code | Name | Severity (warning/error/trip lock) | Description | LCP name |
|--------|----------------|--------------------|------------------------------------|------------------|--------------|
| 0xFF65 | 0x11A | Timing violation 6 | Trip lock | Contact Danfoss. | timing err 6 |

9.3.78 Timing violation 7 (0xFF66 / 0x168)

This error is valid for ISD 520/DSD 520.

Table 126: Timing violation 7 (0xFF66 / 0x168)

| Code | PROFINET® code | Name | Severity (warning/error/trip lock) | Description | LCP name |
|--------|----------------|--------------------|------------------------------------|------------------|--------------|
| 0xFF66 | 0x168 | Timing violation 7 | Trip lock | Contact Danfoss. | timing err 7 |

9.3.79 Timing violation 8 (0xFF67 / 0x16B)

This error is valid for ISD 520/DSD 520.

Table 127: Timing violation 8 (0xFF67 / 0x16B)

| Code | PROFINET® code | Name | Severity (warning/error/trip lock) | Description | LCP name |
|--------|----------------|--------------------|------------------------------------|------------------|--------------|
| 0xFF67 | 0x16B | Timing violation 8 | Trip lock | Contact Danfoss. | timing err 8 |

9.3.80 Timing violation 9 (0xFF68 / 0x16C)

This error is valid for ISD 520/DSD 520.

Table 128: Timing violation 9 (0xFF68 / 0x16C)

| Code | PROFINET® code | Name | Severity (warning/error/trip lock) | Description | LCP name |
|--------|----------------|--------------------|------------------------------------|------------------|--------------|
| 0xFF68 | 0x16C | Timing violation 9 | Trip lock | Contact Danfoss. | timing err 9 |

9.3.81 Firmware: Package description mismatch (0xFF70 / 0x11B)

This error is valid for PSM 510, DAM 510, ACM 510, and ISD 520/DSD 520.

Table 129: Firmware: Package description mismatch (0xFF70 / 0x11B)

| Code | PROFINET® code | Name | Severity (warning/error/trip lock) | Description | LCP name |
|--------|----------------|--|------------------------------------|--|-------------|
| 0xFF70 | 0x11B | Firmware: Package description mismatch | Trip lock | The firmware found does not match the package description. | FW pack err |

9.3.82 Firmware: Power cycle needed (0xFF71 / 0x11C)

This error is valid for PSM 510, DAM 510, ACM 510, and ISD 520/DSD 520.

Table 130: Firmware: Power cycle needed (0xFF71 / 0x11C)

| Code | PROFINET® code | Name | Severity (warning/error/trip lock) | Description | LCP name |
|--------|----------------|------------------------------|------------------------------------|--|-----------------|
| 0xFF71 | 0x11C | Firmware: Power cycle needed | Warning, error | The firmware update transfer is completed but a power cycle is required before the new firmware is active. | need powercycle |

9.3.83 Firmware: Update started (0xFF72 / 0x11D)

This error is valid for PSM 510, DAM 510, ACM 510, and ISD 520/DSD 520.

Table 131: Firmware: Update started (0xFF72 / 0x11D)

| Code | PROFINET® code | Name | Severity (warning/error/trip lock) | Description | LCP name |
|--------|----------------|--------------------------|------------------------------------|---|-----------|
| 0xFF72 | 0x11D | Firmware: Update started | Warning, error | Firmware update is in progress. Warning changes to error when an attempt is made to enable the device in this state. | FW update |

9.3.84 Firmware: Update invalid (0xFF73 / 0x15B)

This error is valid for PSM 510 and DAM 510.

Table 132: Firmware: Update invalid (0xFF73 / 0x15B)

| Code | PROFINET® code | Name | Severity (warning/error/trip lock) | Description | LCP name |
|--------|----------------|--------------------------|------------------------------------|---|----------------|
| 0xFF73 | 0x15B | Firmware: Update invalid | Error | Invalid or corrupted firmware package update. Last valid firmware package has been loaded. | FW upd invalid |

9.3.85 STO active while drive enabled (0xFF80 / 0x11E)

This error is valid for ISD 520/DSD 520.

Table 133: STO active while drive enabled (0xFF80 / 0x11E)

| Code | PROFINET® code | Name | Severity (warning/error/trip lock) | Description | LCP name |
|--------|----------------|--------------------------------|------------------------------------|--|------------|
| 0xFF80 | 0x11E | STO active while drive enabled | Error | STO activated while drive was enabled or tried to enable the drive while STO active. | STO active |

9.3.86 STO mismatch (0xFF81 / 0x11F)

This error is valid for ISD 520/DSD 520.

Table 134: STO mismatch (0xFF81 / 0x11F)

| Code | PROFINET® code | Name | Severity (warning/error/trip lock) | Description | LCP name |
|--------|----------------|--------------|------------------------------------|--|--------------|
| 0xFF81 | 0x11F | STO mismatch | Trip lock | Dual diagnosis of STO voltage not plausible. | STO mismatch |

9.3.87 Guide value reversed (0xFF90 / 0x121)

This error is valid for ISD 520/DSD 520.

Table 135: Guide value reversed (0xFF90 / 0x121)

| Code | PROFINET® code | Name | Severity (warning/error/trip lock) | Description | LCP name |
|--------|----------------|----------------------|------------------------------------|--|---------------|
| 0xFF90 | 0x121 | Guide value reversed | Error | Position guide value went backwards while the servo drive was in CAM mode. | guide val rev |

9.3.88 Guide value implausible (0xFF91 / 0x122)

This error is valid for ISD 520/DSD 520.

Table 136: Guide value implausible (0xFF91 / 0x122)

| Code | PROFINET® code | Name | Severity (warning/error/trip lock) | Description | LCP name |
|--------|----------------|-------------------------|------------------------------------|---|----------------|
| 0xFF91 | 0x122 | Guide value implausible | Error | Increments between succeeding values too large. | guide val impl |

9.3.89 UDU Guide Value out of range (0xFF92 / 0x126)

This error is valid for ISD 520/DSD 520.

Table 137: UDU Guide Value out of range (0xFF92 / 0x126)

| Code | PROFINET® code | Name | Severity (warning/error/trip lock) | Description | LCP name |
|--------|----------------|------------------------------|------------------------------------|--|---------------------|
| 0xFF92 | 0x126 | UDU Guide Value out of range | Error | UDU Position Guide Value is outside the allowable range $[G_{min}, G_{max}]$. | UDU GV out of range |

9.3.90 UDU Guide Value Offset out of range (0xFF93 / 0x12A)

This error is valid for ISD 520/DSD 520.

Table 138: UDU Guide Value Offset out of range (0xFF93 / 0x12A)

| Code | PROFINET® code | Name | Severity (warning/error/trip lock) | Description | LCP name |
|--------|----------------|-------------------------------------|------------------------------------|---|----------------------------|
| 0xFF93 | 0x12A | UDU Guide Value Offset out of range | Error | UDU Position Guide Value offset is outside the allowable range $[G_{min}, G_{max}]$. | UDU GV offset out of range |

9.3.91 UDU Min Blending distance out of range (0xFF94 / 0x12C)

This error is valid for ISD 520/DSD 520.

Table 139: UDU Min Blending distance out of range (0xFF94 / 0x12C)

| Code | PROFINET® code | Name | Severity (warning/error/trip lock) | Description | LCP name |
|--------|----------------|--|------------------------------------|---|--|
| 0xFF94 | 0x12C | UDU Min Blending distance out of range | Error | UDU Min Blending distance is outside the allowable range $[G_{min}, G_{max}]$. | UDU Min Blending distance out of range |

9.3.92 Sign of life error (0xFF95 / 0x14E)

This error is valid for ISD 520/DSD 520.

Table 140: Sign of life error (0xFF95 / 0x14E)

| Code | PROFINET® code | Name | Severity (warning/error/trip lock) | Description | LCP name |
|--------|----------------|--------------------|------------------------------------|-------------------------------|----------------|
| 0xFF95 | 0x14E | Sign of life error | Error | PROFINET® sign of life error. | PNIO SOL error |
| | | | | Sign of life error. | SOL error |

9.3.93 Safe Drive Internal Failure (0xFF96 / 0x150)

This error is valid for ISD 520/DSD 520.

Table 141: Safe Drive Internal Failure (0xFF96 / 0x150)

| Code | PROFINET® code | Name | Severity (warning/error/trip lock) | Description | LCP name |
|--------|----------------|-----------------------------|------------------------------------|-----------------------------|---------------|
| 0xFF96 | 0x150 | Safe Drive Internal Failure | Trip lock | Safe drive internal failure | Safe drv fail |

9.3.94 SIM Internal Failure (0xFF97 / 0x16E)

This error is valid for ISD 520/DSD 520.

Table 142: Safe Drive Internal Failure (0xFF97 / 0x16E)

| Code | PROFINET® code | Name | Severity (warning/error/trip lock) | Description | LCP name |
|--------|----------------|----------------------|------------------------------------|----------------------|----------|
| 0xFF97 | 0x16E | SIM Internal Failure | Trip lock | SIM internal failure | SIM fail |

9.3.95 SIM Internal Failure Resettable (0xFF98 / 0x174)

This error is valid for ISD 520/DSD 520.

Table 143: Safe Internal Failure Resettable (0xFF98 / 0x174)

| Code | PROFINET® code | Name | Severity (warning/error/trip lock) | Description | LCP name |
|--------|----------------|---------------------------------|------------------------------------|----------------------------------|--------------|
| 0xFF98 | 0x174 | SIM Internal Failure Resettable | Error | SIM internal failure resettable. | SIM fail res |

9.3.96 Safe Position Procedure Failed (0xFF99 / 0x175)

This error is valid for ISD 520/DSD 520.

Table 144: Safe Position Procedure Failed (0xFF99 / 0x175)

| Code | PROFINET® code | Name | Severity (warning/error/trip lock) | Description | LCP name |
|--------|----------------|--------------------------------|------------------------------------|---|----------------|
| 0xFF99 | 0x175 | Safe Position Procedure Failed | Warning, error | Procedure for the safe position referencing failed. | Safe Proc Fail |

10 Maintenance, Decommissioning, and Disposal

10.1 Warnings

WARNING

HIGH VOLTAGE

Potentially lethal voltage is present on the connectors that may lead to death or serious injury.

- Before working on the power or signal connectors (disconnecting or connecting the cable), or performing any maintenance work, disconnect the Power Supply Module (PSM 510) from the mains and wait for the discharge time to elapse.

WARNING

DISCHARGE TIME

The servo system contains DC-link capacitors that remain charged for some time after the mains supply is switched off at the Power Supply Module (PSM 510). Failure to wait the specified time after power has been removed before performing service or repair work could result in death or serious injury.

- To avoid electric shock, fully disconnect the Power Supply Module (PSM 510) from the mains and wait for the capacitors to fully discharge before carrying out any maintenance work on the servo system or replacing components.

| Minimum waiting time (minutes) |
|--------------------------------|
| 15 |

10.2 Inspection During Operation

10.2.1 ISD 520/DSD 520 Servo Drives

Carry out regular inspections during operation. Check the ISD 520/DSD 520 servo drives at regular intervals for anything unusual.

Pay particular attention to:

- Unusual noises
- Overheated surfaces (temperatures up to 100 °C can occur in normal operation)
- Uneven running
- Strong vibrations
- Loose fastenings
- Condition of electrical wiring and cables
- Poor heat dispersion

10.2.2 System Modules

Carry out regular inspections during operation.

Check:

- The cooling vents are not blocked.
- The fan is not making any unusual noises.
- The condition of electrical wiring and cables.

10.3 Maintenance Tasks

The maintenance tasks for the ISD 520/DSD 520 servo drives are detailed in [Table 145](#). Only the shaft seal on the ISD 520 (if used) is subject to wear. The maintenance tasks must be performed by qualified personnel. No other tasks are required.

Table 145: Overview of Maintenance Tasks

| Component | Maintenance task | Maintenance interval | Instruction |
|--|--|-------------------------------|---|
| All | Carry out a visual inspection. | Every 6 months | Check for any abnormalities on the surface. |
| Shaft seal on the ISD520 | Check the condition and check for leakage. | Every 6 months ⁽¹⁾ | If damaged or worn: Replace the shaft seal. |
| Mechanical holding brake (optional) | Check the brake. | Every 6 months | Ensure that the brake can achieve the holding torque. |
| Flange connection on the ISD 520 servo drive | Measure the resistance. | Every 12 months. | Measure the resistance of the flange connection on the ISD 520. |
| System modules | Check the fan. | Every 12 months | Check that the fan can turn and remove any dust or dirt. |
| Hybrid cable | Check for damage and wear. | Every 6 months | If damaged or worn: Replace the hybrid cable. |
| Functional safety | Perform a system power cycle and check the STO function. | Every 12 months | Activate STO and check the status with the PLC. |

1) A shorter interval may be necessary depending on the application. Contact Danfoss for more information.

10.4 Repair

Do not attempt to repair the products. Defective products must be returned to Danfoss. Contact the local Danfoss sales company for information about returns.

10.5 ISD 520/DSD 520 Servo Drive Replacement

10.5.1 Dismounting the ISD 520/DSD 520 Servo Drive

Procedure:

1. Disconnect the supply and wait for the discharge time to elapse.
2. Disconnect the electrical cables.
3. Dismount the servo drive.
4. Replace the servo drive with a servo drive of the same type. See the *VLT® Servo Drive System ISD 520, DSD 520, MSD 520 (VLT® FlexMotion™) Design Guide* for code numbers.

10.5.2 Fitting and Commissioning the ISD 520/DSD 520 Servo Drive

Procedure:

1. Check if preparation is required (see [4.6.1 Preparation for Installation of ISD 520/DSD 520 Servo Drive](#)).
2. Fit the servo drive (see [4.7.5.2 Clamping the ISD 520 Servo Drive](#) and [4.7.6.2 Clamping the DSD 520 Servo Drive](#)).
3. Connect the hybrid cables (see [5.10.3 Connecting Hybrid Cables](#)).
4. Connect the I/O and/or encoder cables (see [5.10.5.2 Connecting I/O Cables to Ports X3 and X4](#)).
5. Configure the servo drive parameters according to the fieldbus used (see [6.3 EtherCAT® ID Assignment](#), and POWERLINK® ID Assignment ([6.4.2 Single Device ID Assignment](#) and [6.4.3 Multiple Device ID Assignment](#))).

6. Conduct a test run.

10.6 System Module Replacement

10.6.1 Dismounting the System Modules

1. Disconnect the mains and all auxiliary supplies from the PSM 510 and wait for the discharge time to elapse.
2. Disconnect the EMC plate on the bottom of the system modules. Do not dismantle the connectors from the EMC plate.

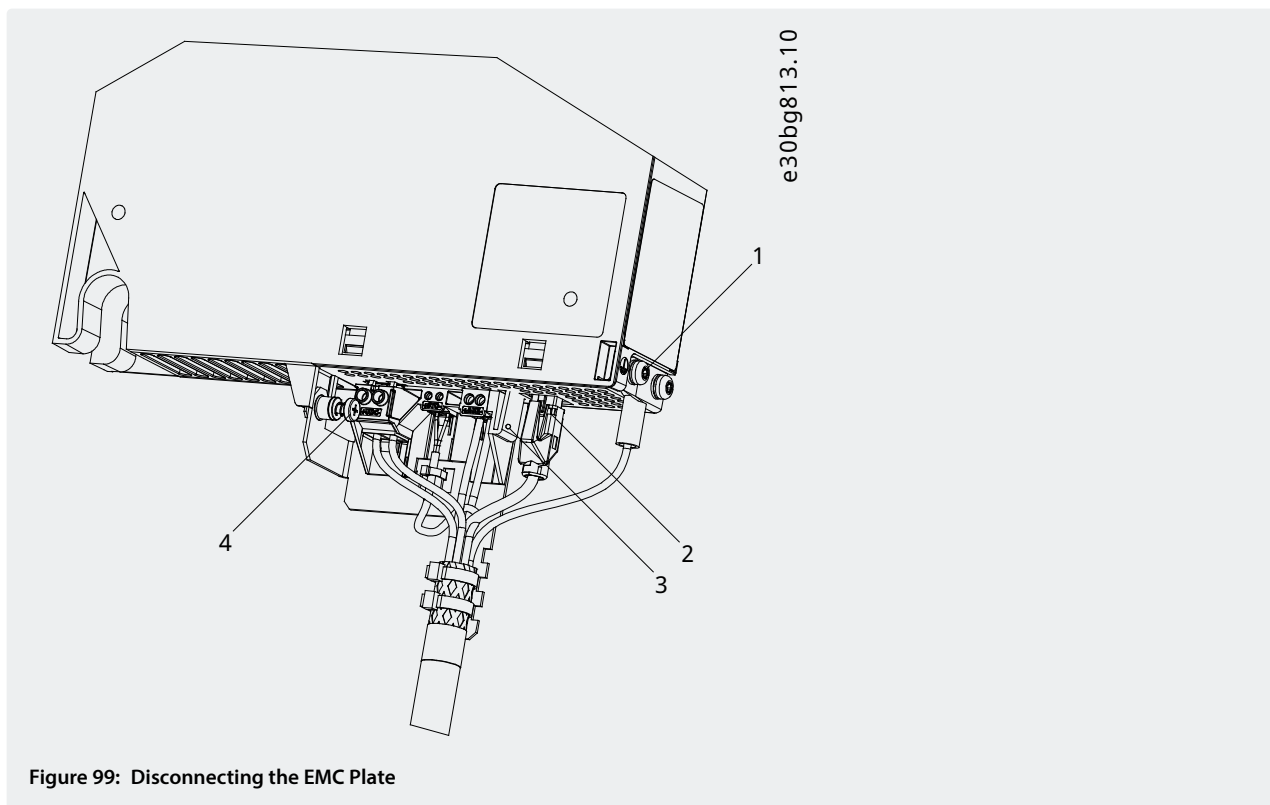

Figure 99: Disconnecting the EMC Plate

- Unplug the RJ45 connector [2] (only on DAM 510).
 - Unscrew the screw [4] on the EMC plate.
 - Press the clip [3] to release the EMC plate.
 - Unscrew the PE screw [1].
3. Disconnect the I/O shielding plate on the top of the system modules:

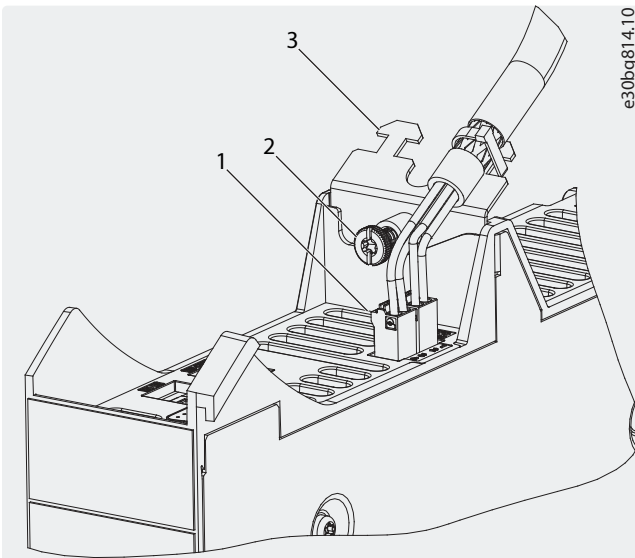

Figure 100: Disconnecting the I/O Shielding Plate

- Unplug the top connectors [1].
 - Unscrew the screw [2] on the I/O shielding plate [3].
 - Pull the I/O shielding plate upwards to remove it.
4. Release the securing clamp [1] at the top of the module.

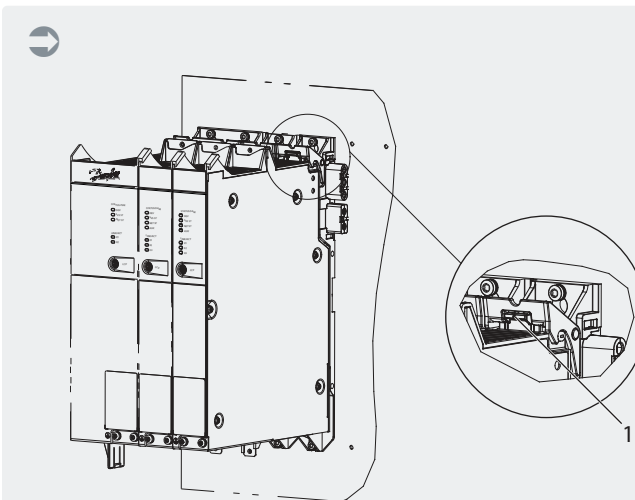
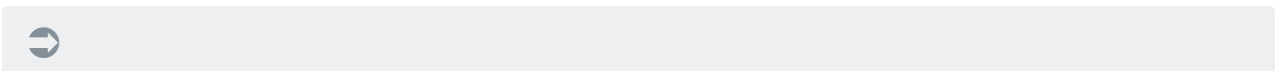

Figure 101: Releasing the Securing Clamp

5. Tilt the module forward and remove it from the backplate.



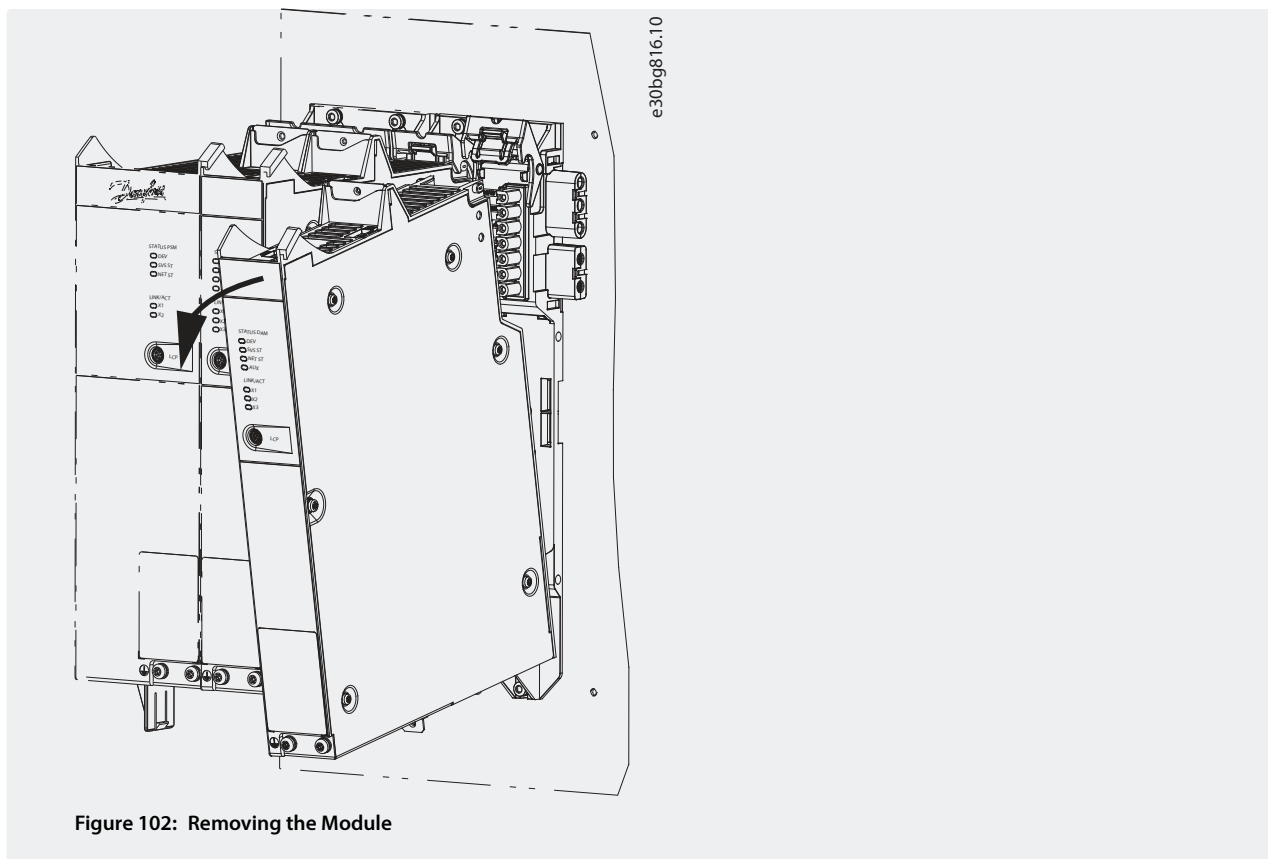

Figure 102: Removing the Module

10.6.2 Fitting and Commissioning the System Modules

1. Check if preparation is required (see [4.6.2 Preparation for Installation of System Modules](#)).
2. Fit the system modules (see [4.7.7 Fitting Instructions for System Modules](#)).
3. Connect the electrical cables (see chapter *Electrical Installation*).
4. Switch the system on (see [6.8 Switching on the ISD 520/DSD 520 System](#)).
5. Configure the parameters of the system module according to the fieldbus used (see [6.3 EtherCAT® ID Assignment](#), [6.5 PROFINET® ID Assignment](#)) and for Ethernet POWERLINK: [6.4.2 Single Device ID Assignment](#) and [6.4.3 Multiple Device ID Assignment](#).
6. Conduct a test run.

10.7 Cable Replacement

10.7.1 Overview

Replace the cables when the rated number of bending cycles has been reached or the cable is damaged.

NOTICE

- Do not forcefully connect or fit the connectors. Incorrect connection causes permanent damage to the connectors.

10.7.2 Feed-in Cable Replacement

10.7.2.1 Disconnecting the Feed-in Cable

1. Disconnect the Power Supply Module (PSM 510) from its power source (mains network and all auxiliary supplies).
2. Wait for the necessary discharge time to elapse.

3. Disconnect any cables connected to the X3, X4, or X5 ports on the ISD 520/DSD 520 servo drive for easier access to the feed-in cable.
4. Disconnect the PE wire from the PE screw on the Decentral Access Module (DAM 510).
5. Disconnect the Ethernet connector.
6. Remove the EMC plate from the DAM 510.
7. Open the cable binder holding the STO cable.
8. Open the cable binder holding the feed-in cable on the DAM 510.
9. Loosen the feed-in cable connectors on the DAM 510.
10. Disconnect the feed-in cable from the DAM 510.
11. Loosen the threaded ring of the connector on the servo drive.
12. Disconnect the feed-in cable from the servo drive.

10.7.2.2 Replacing the Feed-in Cable

Replace the feed-in cable with a cable of identical type and length. See the *VLT® Servo Drive System ISD 520, DSD 520, MSD 520 (VLT® FlexMotion™) Design Guide* for code numbers.

10.7.2.3 Connecting the Feed-in Cable

Procedure:

1. Connect the female connector of the feed-in cable to the male connector of the 1st servo drive.
2. Turn the threaded rings of the connectors hand tight.
3. Ensure that there is no mechanical tension on the cables.
4. Insert the feed-in cable wires into the correct connector on the EMC plate at the bottom of the Decentral Access Module (DAM 510).
5. Secure the feed-in cable with a cable binder.
6. Secure the STO cable with a cable binder.
7. Mount the EMC plate on the DAM 510.
8. Connect the Ethernet connector to the DAM 510.
9. Connect the PE wire to the PE screw on the DAM 510.
10. Reconnect any cables that were connected to the X3, X4, or X5 ports.

10.7.3 Loop Cable Replacement

10.7.3.1 Connecting the Loop Cable

Procedure:

1. Connect the male connector of the loop cable to the female connector on the servo drive.
2. Connect the female connector of the loop cable to the male connector on the adjacent servo drive.
3. Turn the threaded rings hand tight on both servo drives.
4. Ensure that there is no mechanical tension on the cables.
5. Tighten the threaded rings of the connectors on both servo drives.
6. Reconnect any cables that were connected to the X3, X4, or X5 ports on both servo drives.

10.7.3.2 Replacing the Loop Cable

Replace the loop cable with a cable of identical type and length. See the *VLT® Servo Drive System ISD 520, DSD 520, MSD 520 (VLT® FlexMotion™) Design Guide* for code numbers.

10.7.3.3 Disconnecting the Loop Cable

1. Disconnect the Power Supply Module (PSM 510) from its power source (mains network) and all auxiliary supplies.
2. Wait for the necessary discharge time to elapse.
3. Disconnect any cables connected to the X3, X4, or X5 ports on both ISD 520/DSD 520 servo drives for easier access to the loop cable.
4. Loosen the threaded rings of the loop cable connectors on both servo drives.
5. Disconnect the loop cable from the servo drives.

10.8 Fuse Replacement in Decentral Access Module (DAM 510)

If a single fuse blows, replace all the fuses with fuses from the same batch (fuse CAT number 5012006.25, SIBA).

Procedure

1. Remove the screws [1] and remove the cover.

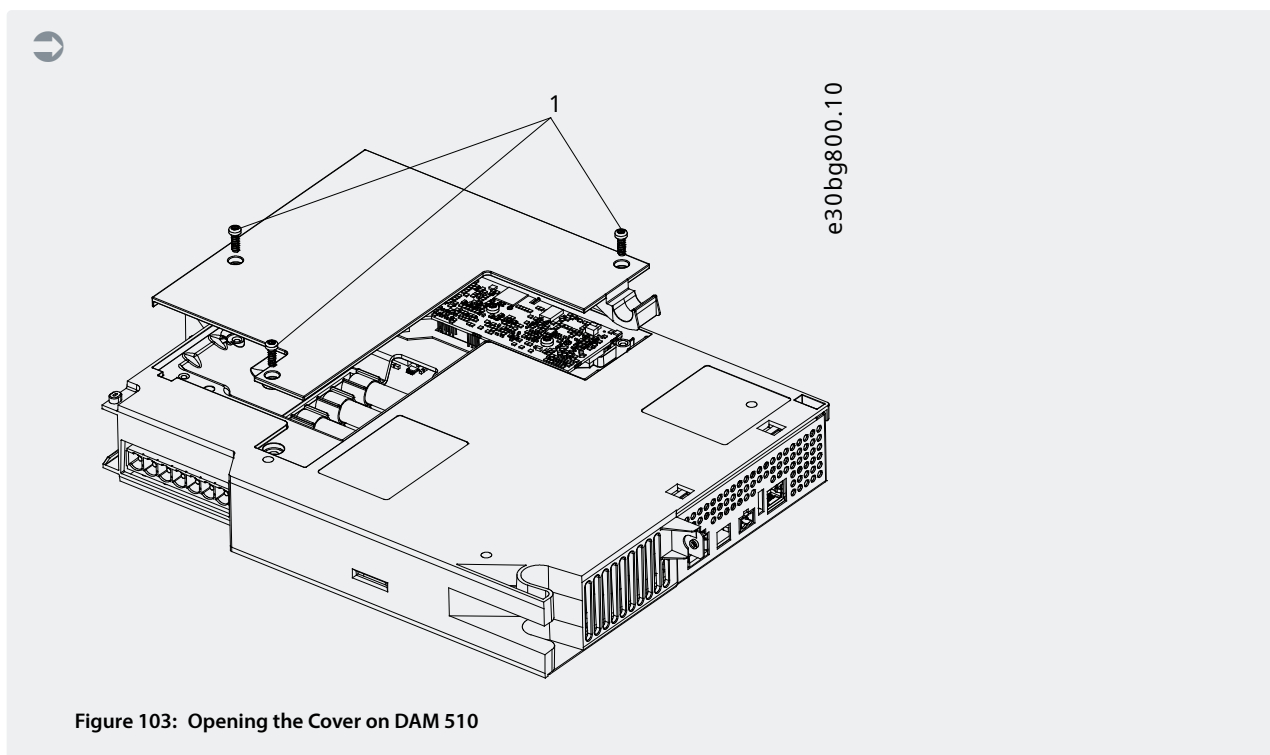

2. Use a screwdriver to remove the fuses and replace them with the same number of identical type fuses.

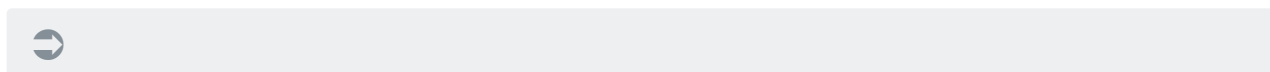

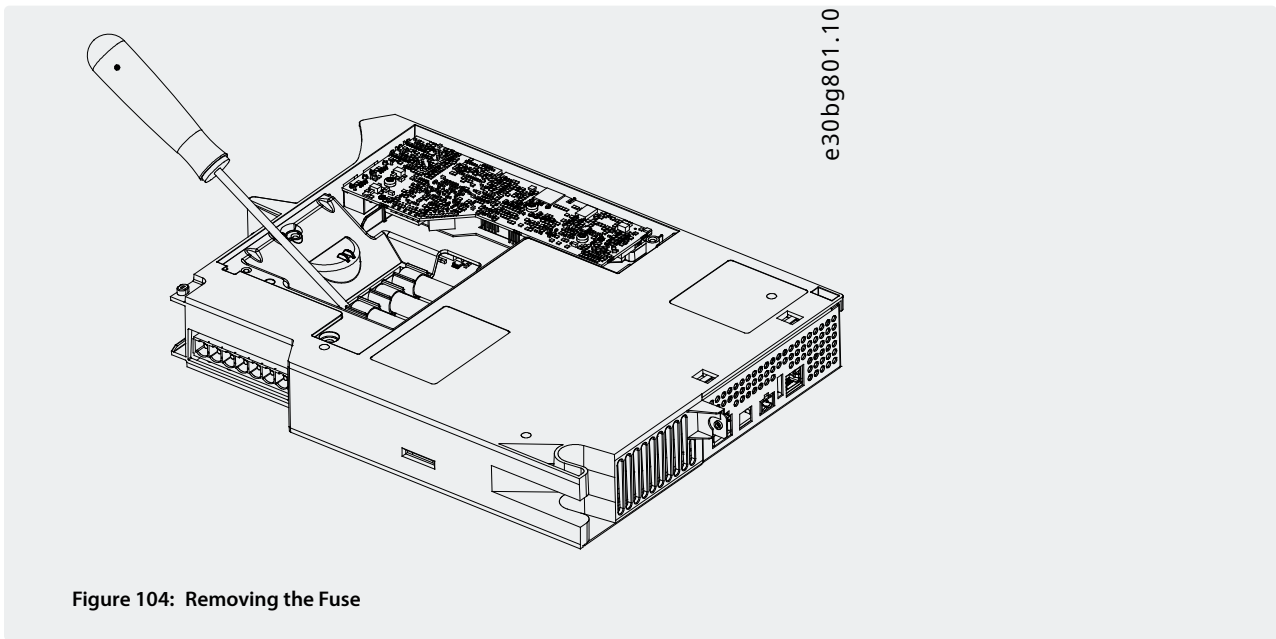

Figure 104: Removing the Fuse

3. Replace the cover and tighten the screws. The tightening torque is 2 Nm.

10.9 Fan Replacement

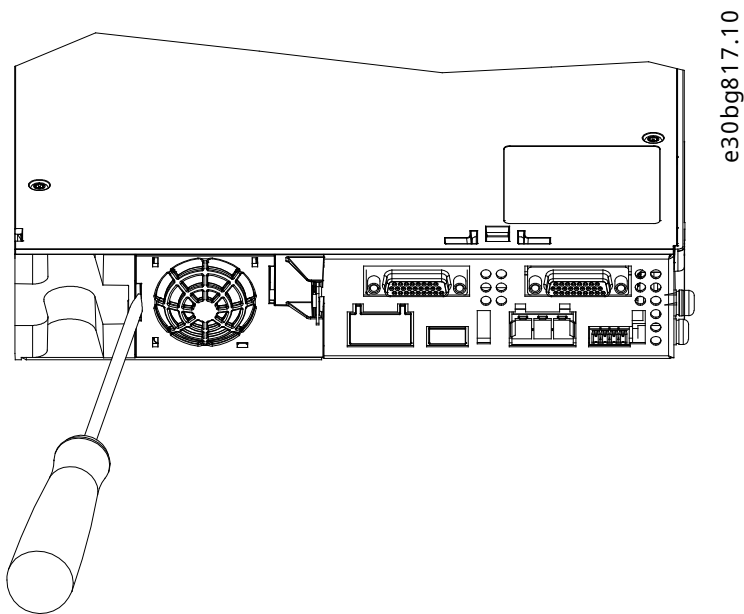

Figure 105: Fan Replacement on 50 mm Modules

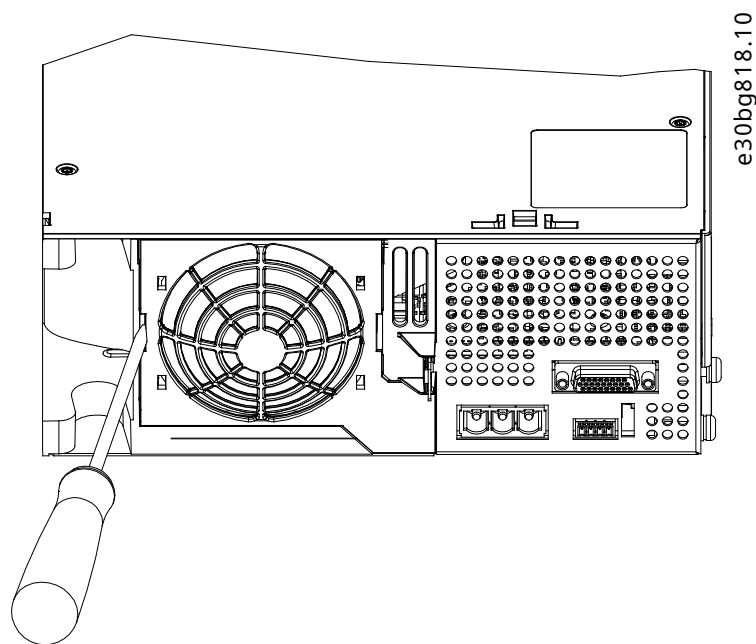

Figure 106: Fan Replacement on 100 mm Modules

NOTICE

- See the *VLT® Servo Drive System ISD 520, DSD 520, MSD 520 (VLT® FlexMotion™)* Design Guide for further information on fan types.

Procedure

1. Use a screwdriver as a lever to release the fan holder.
2. Remove the fan.
3. Replace the fan with an identical type fan.

10.10 Product Returns

Danfoss products can be returned for disposal at no charge. A prerequisite for this is that they are free of deposits, such as oil, grease, or other types of contamination that hampers disposal. Furthermore, foreign materials or third-party components cannot be included with the returned product.

Ship the products free on board to the local Danfoss sales company.

10.11 Recycling

Take metals and plastics to recycling stations.

The servo drives and system modules are classified as electronic waste, and the packaging is classified as packaging waste.

10.12 Disposal

Devices containing electronic components cannot be disposed of as normal domestic waste.

Dispose of the servo drives and system modules as hazardous waste, electrical waste, recyclable waste, and so on, in accordance with applicable local regulations.

11 Specifications

11.1 Product Labels

11.1.1 Product Labels on the ISD 520/DSD 520 Servo Drive

Check the product label and compare it with the order data. Use the part number for reference. The part number uniquely identifies the drive type.

Ensure that the nameplate is clearly legible.

The servo drives can be identified externally only by the original Danfoss product label.

The following data is shown on the servo drive product label:

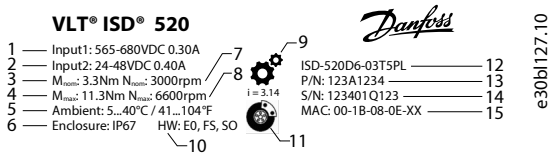

| | | | |
|----|---------------------------|----|-------------------------|
| 1 | Supply voltage | 2 | Auxiliary input voltage |
| 3 | Nominal torque | 4 | Maximum torque |
| 5 | Ambient temperature range | 6 | Protection rating |
| 7 | Rated speed | 8 | Maximum speed |
| 9 | With gear unit | 10 | Hardware configuration |
| 11 | With mechanical brake | 12 | Short model code |
| 13 | Part number | 14 | Serial number |
| 15 | MAC address | | |

Figure 107: Example of a Product Label on the ISD 520 Servo Drive

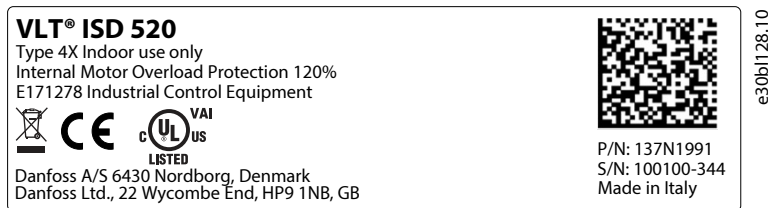
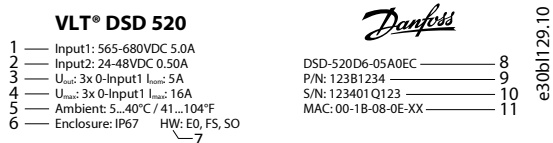

Figure 108: Example of a Tracing and Conformity Label on ISD 520



| | | | |
|----|---------------------------|----|-------------------------|
| 1 | Supply voltage | 2 | Auxiliary input voltage |
| 3 | Output voltage | 4 | Maximum voltage |
| 5 | Ambient temperature range | 6 | Protection rating |
| 7 | Hardware configuration | 8 | Type code |
| 9 | Part number | 10 | Serial number |
| 11 | MAC address | | |

Figure 109: Example of a Product Label on the DSD 520 Servo Drive

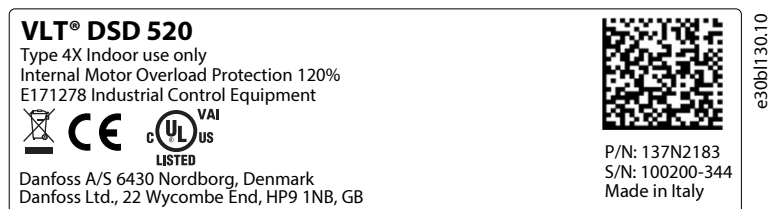
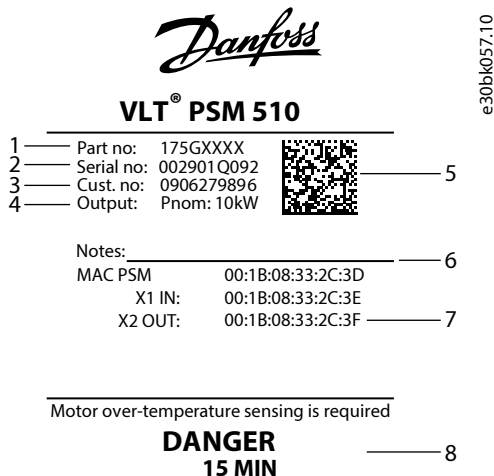

Figure 110: Example of a Tracing and Conformity Label on DSD 520

11.1.2 Product Labels on the System Modules

The following data is shown on the product label on the front of PSM 510.



| | | | |
|---|----------------------|---|---------------|
| 1 | Part number | 2 | Serial number |
| 3 | Customer part number | 4 | Output |
| 5 | Data matrix | 6 | Notes |
| 7 | MAC addresses | 8 | Warning |

Figure 111: Product Label on the Front of PSM 510

The following data is shown on the product label on the front of DAM 510.

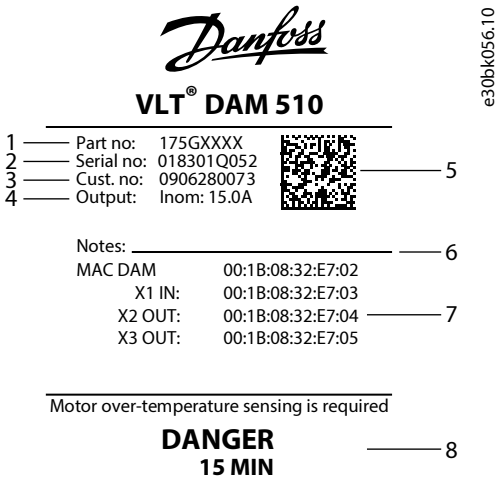

| | | | |
|---|----------------------|---|---------------|
| 1 | Part number | 2 | Serial number |
| 3 | Customer part number | 4 | Output |
| 5 | Data matrix | 6 | Notes |
| 7 | MAC addresses | 8 | Warning |

Figure 112: Product Label on the Front of DAM 510

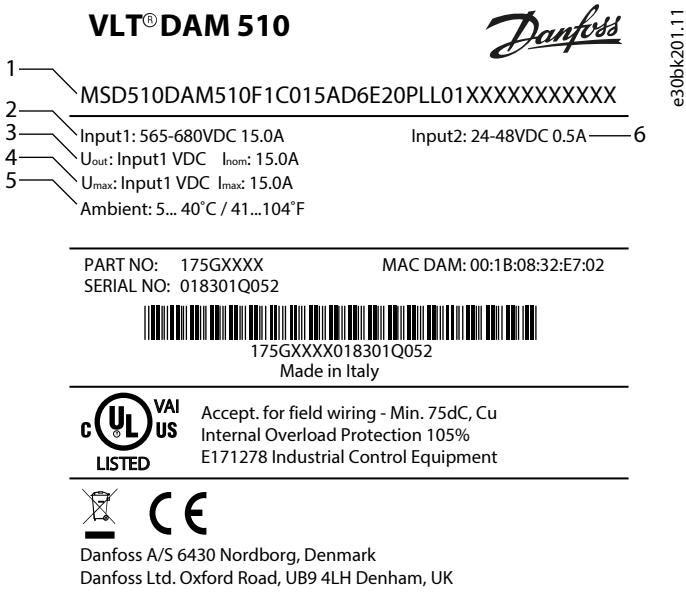

| | | | |
|---|---------------------------|---|-------------------------|
| 1 | Type code | 2 | Supply voltage |
| 3 | Output voltage | 4 | Maximum power |
| 5 | Ambient temperature range | 6 | U _{AUX} supply |

Figure 113: Example Product Label on the Side of the System Modules

11.2 Characteristic Data

11.2.1 Characteristic Data for ISD 520 Servo Drive

11.2.1.1 Common Technical Data for ISD 520 Servo Drives

Table 146: Common Technical Data for ISD 520 Servo Drives

| Specification | Value/Information |
|--------------------------------|--|
| Rated voltage | 565–680 V ±10% V DC |
| U _{AUX} rated voltage | 24/48 V ±10% V DC |
| Protective measure | Overload, short-circuit, and ground fault protection |
| Maximum output frequency | 590 Hz |
| Functional safety | STO |
| Cooling | Natural convection |
| Mounting | Via flange |

11.2.1.2 Characteristic Data for Drive Sizes 1–2 in Normal Speed Range (2000–3000 RPM)

Table 147: Characteristic Data for ISD 520 Servo Drive Sizes 1–2 in Normal Speed Range

| Data | Unit | Drive size | | | | | |
|--|------|----------------|----------------|----------------|----------------|----------------|----------------|
| | | 1 | | 2 | | | |
| – | – | 1 | | 2 | | | |
| Torque level | Nm | 1.5 (-01T5) | 2.5 (-02T5) | 2.5 (-02T5) | 3.5 (-03T5) | 4.0 (-04T0) | 4.5 (-04T5) |
| Speed category | – | +FN30 | +FN20 | +FN30 | | | |
| Flange size | mm | 70 | 87 | 91 | | | |
| Shaft size | mm | 11 | 19 | 14 | | 19 | |
| Rated speed n _{NOM} | RPM | 3000 | 2000 | 3000 | | | |
| DC-link capacitance | µF | 3.6 | 4.0 | 3.6 | | | |
| U _{AUX} power consumption (at 24 V) | W | 8.64 | 9.60 | 8.64 | | | |
| U _{AUX} power consumption (at 24 V with brake) | W | 19.76 | Not applicable | 19.76 | | 29.14 | |
| U _{AUX} current consumption (at 24 V) | A DC | 0.36 | 0.40 | 0.36 | | | |
| U _{AUX} current consumption (at 48 V) | A DC | 0.22 | 0.20 | 0.22 | | | |

Table 147: Characteristic Data for ISD 520 Servo Drive Sizes 1–2 in Normal Speed Range - (continued)

| Data | Unit | Drive size | | | | | |
|--|------|----------------|----------------|----------------|----------------|----------------|----------------|
| | | 1 | | 2 | | | |
| Torque level | Nm | 1.5 (-01T5) | 2.5 (-02T5) | 2.5 (-02T5) | 3.5 (-03T5) | 4.0 (-04T0) | 4.5 (-04T5) |
| Speed category | – | +FN30 | +FN20 | +FN30 | | | |
| Flange size | mm | 70 | 87 | 91 | | | |
| Shaft size | mm | 11 | 19 | 14 | | 19 | |
| U_{AUX} current consumption (at 24 V with brake) | A DC | 0.82 | Not applicable | 0.82 | | 1.21 | |
| U_{AUX} current consumption (at 48 V with brake) | A DC | 0.46 | Not applicable | 0.46 | | 0.65 | |
| UDC input current (at 560 V DC) | V DC | 0.8 | 0.224 | 1.6 | 2.0 | 2.4 | 2.8 |
| Drive rated torque M_{NOM} | Nm | 1.65 | 2.5 | | 3.3 | 4.1 | 4.4 |
| Drive rated current I_{NOM} | A DC | 1.1 | | 1.7 | 2.4 | 2.9 | 3.2 |
| Drive rated power P_{NOM} | kW | 0.518 | 0.65 | 0.8 | 1.2 | 1.4 | 1.5 |
| Drive stall torque M_0 | Nm | 1.8 | 2.6 | | 3.5 | 4.5 | 5.0 |
| Drive stall current I_0 | A DC | 1.2 | 1.1 | 1.8 | 2.5 | 3.2 | 3.6 |
| Drive peak torque M_{MAX} | Nm | 6.3 | 11.0 | 7.5 | 11.3 | 14.3 | 15.5 |
| Drive peak current I_{MAX} | A DC | 6.2 | 6.0 | 7.6 | 11.1 | 12.5 | |
| Pole pairs | – | 4 | 5 | | | | |

11.2.1.3 Characteristic Data for Drive Sizes 3–5 in Normal Speed Range (2000–3000 RPM)

Table 148: Characteristic Data for ISD 520 Servo Drive Sizes 3–5 in Normal Speed Range

| Data | Unit | Drive size | | |
|--|---------|----------------|----------------|-----------------|
| | | 3 | 4 | 5 |
| – | – | 3 | 4 | 5 |
| Torque level | Nm | 5.0 (-05T0) | 9.0 (-09T0) | 14.0 (-14T0) |
| Speed category | – | +FN30 | | +FN22 |
| Flange size | mm | 100 | 116 | 142 |
| Shaft size | mm | 19 | 24 | |
| Rated speed n_{NOM} | RPM | 3000 | | 2200 |
| DC-link capacitance | μ F | 3.6 | 13.2 | |
| U_{AUX} power consumption (at 24 V) | W | 8.64 | 9.36 | |
| U_{AUX} power consumption (at 24 V with brake) | W | 29.14 | 28.62 | 34.08 |
| U_{AUX} current consumption (at 24 V) | A DC | 0.36 | 0.39 | |
| U_{AUX} current consumption (at 48 V) | A DC | 0.22 | 0.23 | |
| U_{AUX} current consumption (at 24 V with brake) | A DC | 1.21 | 1.19 | 1.42 |
| U_{AUX} current consumption (at 48 V with brake) | A DC | 0.65 | 0.64 | 0.76 |
| UDC input current (at 560 V DC) | V DC | 3.0 | 5.2 | 5.9 |
| Drive rated torque M_{NOM} | Nm | 5.2 | 8.2 | 13.8 |
| Drive rated current I_{NOM} | A DC | 3.3 | 5.2 | 6.6 |
| Drive rated power P_{NOM} | kW | 1.7 | 2.7 | 3.3 |
| Drive stall torque M_0 | Nm | 6.4 | 11.2 | 16.0 |
| Drive stall current I_0 | A DC | 3.9 | 7.0 | 7.0 |
| Drive peak torque M_{MAX} | Nm | 16.0 | 29.0 | 39.0 |
| Drive peak current I_{MAX} | A DC | 12.5 | 22.0 | 22.0 |
| Pole pairs | – | 5 | | |

11.2.1.4 Characteristic Data for Drive Sizes 1–2 in High Speed Range (4500–6000 RPM)

Table 149: Characteristic Data for ISD 520 Servo Drive Sizes 1–2 in High Speed Range

| Data | Unit | Drive size | | | |
|---|---------------|----------------|----------------|------------------|------------------|
| | | 1 | 2 | | |
| Torque level | Nm | 1.5 (-01T5) | 2.0 (-02T0) | 2.5 (-02T5) | 3.0 (-03T0) |
| Speed category | – | +FN60 | | | |
| Flange size | mm | 70 | 91 | | |
| Shaft size | mm | 11 | 19 | 14 | |
| Rated speed n_{NOM} | RPM | 6000 | | | |
| DC-link capacitance | μF | 3.6 | | | |
| U_{AUX} power consumption (at 24 V) | W | 8.64 | | | |
| U_{AUX} power consumption (at 24 V with brake) | W | 19.76 | | | |
| U_{AUX} current consumption (at 24 V) | A DC | 0.36 | | | |
| U_{AUX} current consumption (at 48 V) | A DC | 0.22 | | | |
| U_{AUX} current consumption (at 24 V with brake) | A DC | 0.82 | | | 1.21 |
| U_{AUX} current consumption (at 48 V with brake) | A DC | 0.46 | | | 0.65 |
| UDC input current (at 560 V DC) | V DC | 1.37 | 2.5 | – ⁽¹⁾ | – ⁽¹⁾ |
| Drive rated torque M_{NOM} | Nm | 1.5 | 2.1 | – ⁽¹⁾ | – ⁽¹⁾ |
| Drive rated current I_{NOM} | A DC | 2.1 | 2.9 | – ⁽¹⁾ | – ⁽¹⁾ |
| Drive rated power P_{NOM} | kW | 0.94 | 1.3 | – ⁽¹⁾ | – ⁽¹⁾ |
| Drive stall torque M_0 | Nm | 1.8 | 2.6 | – ⁽¹⁾ | – ⁽¹⁾ |
| Drive stall current I_0 | A DC | 2.5 | 3.6 | – ⁽¹⁾ | – ⁽¹⁾ |
| Drive peak torque M_{MAX} | Nm | 6.3 | 7.0 | – ⁽¹⁾ | – ⁽¹⁾ |
| Drive peak current I_{MAX} | A DC | 12.5 | | – ⁽¹⁾ | – ⁽¹⁾ |
| Pole pairs | – | 5 | | 5 | 5 |

1) Available on request.

11.2.1.5 Characteristic Data for Drive Sizes 3–5 in High Speed Range (4500–6000 RPM)

Table 150: Characteristic Data for ISD 520 Servo Drive Sizes 3–5 in High Speed Range

| Data | Unit | Drive size | | | | | |
|--|---------|------------------|------------------|------------------|------------------|------------------|------------------|
| | | 3 | 4 | | 5 | 4 | 5 |
| – | – | 3 | 4 | | 5 | 4 | 5 |
| Torque level | Nm | 4.0 (-04T0) | 5.0 (-05T0) | 6.5 (-06T5) | 8.0 (-08T0) | 8.5 (-08T5) | 12.0 (-12T0) |
| Speed category | – | +FN60 | +FN45 | | | | |
| Flange size | mm | 100 | 116 | | 142 | 116 | 142 |
| Shaft size | mm | 19 | 24 | | | | |
| Rated speed n_{NOM} | RPM | 6000 | 4500 | | | | |
| DC-link capacitance | μ F | 13.2 | | | | | |
| U_{AUX} power consumption (at 24 V) | W | 8.64 | 9.36 | | | | |
| U_{AUX} power consumption (at 24 V with brake) | W | 29.14 | 28.62 | | 34.08 | | |
| U_{AUX} current consumption (at 24 V) | A DC | 0.36 | 0.39 | | | | |
| U_{AUX} current consumption (at 48 V) | A DC | 0.22 | 0.23 | | | | |
| U_{AUX} current consumption (at 24 V with brake) | A DC | 1.21 | 1.19 | | 1.42 | | |
| U_{AUX} current consumption (at 48 V with brake) | A DC | 0.65 | 0.64 | | 0.76 | | |
| UDC input current (at 560 V DC) | V DC | – ⁽¹⁾ | – ⁽¹⁾ | – ⁽¹⁾ | – ⁽¹⁾ | – ⁽¹⁾ | – ⁽¹⁾ |
| Drive rated torque M_{NOM} | Nm | – ⁽¹⁾ | – ⁽¹⁾ | – ⁽¹⁾ | – ⁽¹⁾ | – ⁽¹⁾ | – ⁽¹⁾ |
| Drive rated current I_{NOM} | A DC | – ⁽¹⁾ | – ⁽¹⁾ | – ⁽¹⁾ | – ⁽¹⁾ | – ⁽¹⁾ | – ⁽¹⁾ |
| Drive rated power P_{NOM} | kW | – ⁽¹⁾ | – ⁽¹⁾ | – ⁽¹⁾ | – ⁽¹⁾ | – ⁽¹⁾ | – ⁽¹⁾ |
| Drive stall torque M_0 | Nm | – ⁽¹⁾ | – ⁽¹⁾ | – ⁽¹⁾ | – ⁽¹⁾ | – ⁽¹⁾ | – ⁽¹⁾ |
| Drive stall current I_0 | A DC | – ⁽¹⁾ | – ⁽¹⁾ | – ⁽¹⁾ | – ⁽¹⁾ | – ⁽¹⁾ | – ⁽¹⁾ |
| Drive peak torque M_{MAX} | Nm | – ⁽¹⁾ | – ⁽¹⁾ | – ⁽¹⁾ | – ⁽¹⁾ | – ⁽¹⁾ | – ⁽¹⁾ |
| Drive peak current I_{MAX} | A DC | – ⁽¹⁾ | – ⁽¹⁾ | – ⁽¹⁾ | – ⁽¹⁾ | – ⁽¹⁾ | – ⁽¹⁾ |
| Pole pairs | – | 5 | | | | | |

1) Available on request.

11.2.1.6 Mechanical Data for Drive Sizes 1–2 in Normal Speed Range (2000–3000 RPM)

Table 151: Mechanical Data for ISD 520 Servo Drive Sizes 1–2 in Normal Speed Range

| Data | Unit | Drive size | | | | | |
|--------------------------|-----------------------------------|----------------|----------------|----------------|----------------|----------------|----------------|
| | | 1 | | 2 | | | |
| – | – | | | | | | |
| Torque level | Nm | 1.5 (-01T5) | 2.5 (-02T5) | 2.5 (-02T5) | 3.5 (-03T5) | 4.0 (-04T0) | 4.5 (-04T5) |
| Speed category | – | +FN30 | +FN20 | +FN30 | | | |
| Flange size | mm | 70 | 87 | 91 | | | |
| Shaft size | mm | 11 | 19 | 14 | | 19 | |
| Rated speed n_{NOM} | RPM | 3000 | 2000 | 3000 | | | |
| Brake inertia | kgcm ² | 0.4 | Not applicable | 0.4 | | 0.7 | |
| Brake weight | kg | 0.35 | Not applicable | 0.6 | | 1.1 | |
| Brake power | W | 10.8 | Not applicable | 10.8 | | 19.9 | |
| Brake holding torque | Nm | 3.2 | Not applicable | 3.2 | | 8.0 | |
| Flange thickness | mm | 9 | 42.5 | 11 | | | |
| Bolt circle | Ø mm | 75 | 95 | 100 | | | |
| Mounting hole | Ø mm | 5.8 | 6.0 | 6.5 | | | |
| Centering ring | Ø mm | 60 j6 | 80 j6 | | | | |
| Shaft length | mm | 23 | 40 | 30 | | 40 | |
| Inertia J | 10 ⁻⁴ Kgm ² | 0.63 | 1.6 | 0.80 | 1.10 | 1.50 | 1.80 |
| Weight (without brake) | kg | 3.9 | 4.1 | 3.8 | 4.5 | 5.2 | 5.7 |
| Key dimensions | mm | 4 x 4 x 15 | 6 x 6 x 32 | 5 x 5 x 22 | | 6 x 6 x 32 | |
| Shaft hole | – | M4 | M6 | M5 | | M6 | |
| Axial forces | N | 17 | 45 | 22 | 24 | 58 | 66 |
| Radial forces | N | 168 | 450 | 220 | 235 | 580 | 660 |

11.2.1.7 Mechanical Data Drive Sizes 3–5 in Normal Speed Range (2000–3000 RPM)

Table 152: Mechanical Data for ISD 520 Servo Drive Sizes 3–5 in Normal Speed Range

| Data | Unit | Drive size | | |
|------------------------|-----------------------------------|----------------|----------------|-----------------|
| | | 3 | 4 | 5 |
| – | – | | | |
| Torque level | Nm | 5.0 (-05T0) | 9.0 (-09T0) | 14.0 (-14T0) |
| Speed category | – | +FN30 | | +FN22 |
| Flange size | mm | 100 | 116 | 142 |
| Shaft size | mm | 19 | 24 | |
| Rated speed n_{NOM} | RPM | 3000 | | 2200 |
| Brake inertia | kgcm ² | 0.7 | 3.6 | 1.7 |
| Brake weight | kg | 1.1 | 1.5 | 1.4 |
| Brake power | W | 19.9 | 18.7 | 24.0 |
| Brake holding torque | Nm | 8.0 | 17.0 | 15.0 |
| Flange thickness | mm | 10 | 12 | |
| Bolt circle | Ø mm | 115 | 130 | 165 |
| Mounting hole | Ø mm | 9.0 | | 12.5 |
| Centering ring | Ø mm | 95 j6 | 110 j6 | 130 j6 |
| Shaft length | mm | 40 | 50 | |
| Inertia J | 10 ⁻⁴ Kgm ² | 2.6 | 5.10 | 9.8 |
| Weight (without brake) | kg | 6.6 | 9.2 | 11.9 |
| Key dimensions | mm | 6 x 6 x 32 | 8 x 7 x 40 | |
| Shaft hole | – | M6 | M8 | |
| Axial forces | N | 58 | 64 | 70 |
| Radial forces | N | 580 | 640 | 695 |

11.2.1.8 Mechanical Data for Drive Sizes 1–2 in High Speed Range (4500–6000 RPM)

Table 153: Mechanical Data for ISD 520 Servo Drive Sizes 1–2 in High Speed Range

| Data | Unit | Drive size | | | |
|-----------------------|-------------------|-------------------|-------------------|-------------------|-------------------|
| | | 1 | 2 | | |
| – | – | | | | |
| Torque level | Nm | 1.5 Nm (-01T5) | 2.0 Nm (-02T0) | 2.5 Nm (-02T5) | 3.0 Nm (-03T0) |
| Speed category | – | +FN60 | | | |
| Flange size | mm | 70 | 91 | | |
| Shaft size | mm | 11 | 19 | 14 | |
| Rated speed n_{NOM} | RPM | 6000 | | | |
| Brake inertia | kgcm ² | 0.4 | | | 0.7 |
| Brake weight | kg | 0.35 | 0.6 | | 1.1 |
| Brake power | W | 10.8 | | | 19.9 |

Table 153: Mechanical Data for ISD 520 Servo Drive Sizes 1–2 in High Speed Range - (continued)

| Data | Unit | Drive size | | | |
|------------------------|------------------------------------|-------------------|-------------------|-------------------|-------------------|
| | | 1 | 2 | | |
| – | – | | | | |
| Torque level | Nm | 1.5 Nm (-01T5) | 2.0 Nm (-02T0) | 2.5 Nm (-02T5) | 3.0 Nm (-03T0) |
| Speed category | – | +FN60 | | | |
| Flange size | mm | 70 | 91 | | |
| Shaft size | mm | 11 | 19 | 14 | |
| Brake holding torque | Nm | 3.2 | | | 8.0 |
| Flange thickness | mm | 9 | 11 | | |
| Bolt circle | ∅ mm | 75 | 100 | | |
| Mounting hole | ∅ mm | 5.8 | 6.5 | | |
| Centering ring | ∅ mm | 60 j6 | 80 j6 | | |
| Shaft length | mm | 23 | 30 | | 40 |
| Inertia J | 10 ⁻⁴ Kg·m ² | 0.63 | 0.80 | 1.10 | 1.50 |
| Weight (without brake) | kg | 3.9 | 3.8 | 4.5 | 5.2 |
| Key dimensions | mm | 4 x 4 x 15 | 5 x 5 x 22 | | 6 x 6 x 32 |
| Shaft hole | – | M4 | M5 | | M6 |
| Axial forces | N | 17 | 13 | 14 | 31 |
| Radial forces | N | 168 | 130 | 140 | 310 |

11.2.1.9 Mechanical Data for Drive Sizes 3–5 in High Speed Range (4500–6000 RPM)

Table 154: Mechanical Data for ISD 520 Servo Drive Sizes 3–5 in High Speed Range

| Data | Unit | Drive size | | | | | |
|---------------------------------|--------------------|-------------------|-------------------|-------------------|-------------------|-------------------|--------------------|
| | | 3 | 4 | | 5 | 4 | 5 |
| – | – | | | | | | |
| Torque level | Nm | 4.0 Nm (-04T0) | 5.0 Nm (-05T0) | 6.5 Nm (-06T5) | 8.0 Nm (-08T0) | 8.5 Nm (-08T5) | 12.0 Nm (-12T0) |
| Speed category | – | +FN60 | +FN45 | | | | |
| Flange size | mm | 100 | 116 | | 142 | 116 | 142 |
| Shaft size | mm | 19 | 24 | | | | |
| Rated speed n _{NOM} | RPM | 6000 | 4500 | | | | |
| Brake inertia | kg·cm ² | 0.7 | 3.6 | | 1.7 | 3.6 | 1.7 |
| Brake weight | kg | 1.1 | 1.5 | | 1.4 | 1.5 | 1.4 |
| Brake power | W | 19.9 | 18.7 | | 24.0 | 18.7 | 24.0 |
| Brake holding torque | Nm | 8.0 | 17.0 | | 15.0 | 17.0 | 15.0 |

Table 154: Mechanical Data for ISD 520 Servo Drive Sizes 3–5 in High Speed Range - (continued)

| Data | Unit | Drive size | | | | | |
|------------------------|-----------------------------------|-------------------|-------------------|-------------------|-------------------|-------------------|--------------------|
| | | 3 | 4 | | 5 | 4 | 5 |
| Torque level | Nm | 4.0 Nm (-04T0) | 5.0 Nm (-05T0) | 6.5 Nm (-06T5) | 8.0 Nm (-08T0) | 8.5 Nm (-08T5) | 12.0 Nm (-12T0) |
| Speed category | – | +FN60 | +FN45 | | | | |
| Flange size | mm | 100 | 116 | | 142 | 116 | 142 |
| Shaft size | mm | 19 | 24 | | | | |
| Flange thickness | mm | 10 | 12 | | | | |
| Bolt circle | Ø mm | 115 | 130 | | | | 165 |
| Mounting hole | Ø mm | 9.0 | | | | | 12.5 |
| Centering ring | Ø mm | 95 j6 | 110 j6 | | | | 130 j6 |
| Shaft length | mm | 40 | 50 | | | | |
| Inertia J | 10 ⁻⁴ Kgm ² | 2.6 | 2.8 | 5.1 | | 7.3 | 9.8 |
| Weight (without brake) | kg | 7.3 | 7.3 | 9.2 | | 10.1 | 11.1 |
| Key dimensions | mm | 6 x 6 x 32 | 8 x 7 x 40 | | | | |
| Shaft hole | – | M6 | M8 | | | | |
| Axial forces | N | 40 | 49 | 51 | 57 | 53 | 59 |
| Radial forces | N | 395 | 490 | 510 | 565 | 530 | 590 |

11.2.2 Characteristic Data for DSD 520 Servo Drive

Table 155: Characteristic Data for DSD 520

| Specifications | Unit | DSD 520, E1, 5 A |
|--|-------|---------------------|
| Input | | |
| UDC rated voltage | V DC | 565–680 ±10% |
| UDC input current (at 560 V DC) | A DC | 5.0 |
| DC-link capacitance | µF | 3.6 |
| U _{AUX} rated voltage | V DC | 24/48 ±10% |
| U _{AUX} power consumption (at 24 V) | W | 12.0 |
| U _{AUX} current consumption (at 24 V) | A DC | 0.5 |
| U _{AUX} current consumption (at 48 V) | A DC | 0.25 |
| Output | | |
| Output number of phases | – | 3 |
| Output voltage | V AC | V _{IN} PSM |
| Drive rated current I _{NOM} | A rms | 4.5 |
| Drive rated power P _{NOM} | kW | 2.3 |

Table 155: Characteristic Data for DSD 520 - (continued)

| Specifications | Unit | DSD 520, E1, 5 A |
|---------------------------------------|-------|---|
| Drive peak current I_{MAXmax} | A rms | 12.5 |
| Nominal switching frequency f_{sw} | kHz | 8/10 |
| Possible switching frequency f_{sw} | kHz | 4/5 |
| Protective measures | – | Overload, short-circuit, and ground fault protection. |
| Maximum output frequency | Hz | 590 |
| Functional safety | – | STO (standard)/VLT® FlexSafety™ (optional) |
| Cooling | – | Natural convection |
| Mounting | – | Screw-mounted via base and side |
| Number of motor connectors | – | 1 |
| Weight | kg | 1.7 |
| Dimensions (W x H x D) | mm | 95.1 x 153.5 x 150 |

11.2.3 Characteristic Data for Power Supply Module (PSM 510)

Table 156: Characteristic Data for PSM 510

| Definition | Unit | Power size 1 | Power size 2 | Power size 3 |
|--|------|--|--------------|--------------|
| Input | | | | |
| Mains input voltage | V AC | 400–480 ±10%, 3-phase (see 5.2 Electrical Environmental Conditions) | | |
| Input current @ U_{MIN} | A | 20 | 34 | 50 |
| Input power | kVA | 12.5 | 22 | 32 |
| U_{AUX} input voltage | V DC | 24/48 ±10% | | |
| U_{AUX} current consumption at 24 V DC | A DC | 2.0 | | |
| U_{AUX} current consumption at 48 V DC | A DC | 1.0 | | |
| Output | | | | |
| DC-link voltage | V DC | 565–680 ±10% | | |
| DC-link capacitance | μF | 1800 | | |
| Rated current I_N | A | 20 | 40 | 60 |
| Rated power P_N | kW | 10 | 20 | 30 |
| Peak power P_{max} $t < 3.0$ s) | kW | 20 | 40 | 60 |
| Internal brake resistor⁽¹⁾ | | | | |
| Peak power P_{max} | kW | 8 | | |
| Rated power P_N | W | 150 | | |
| Nominal resistance | Ω | 15 | | |
| External brake resistor | | | | |

Table 156: Characteristic Data for PSM 510 - (continued)

| Definition | Unit | Power size 1 | Power size 2 | Power size 3 |
|---|----------|--|--------------|--------------|
| Peak power P_{max} | kW | | 60 | |
| Rated power P_N | kW | | 7.5 | |
| Minimum resistance | Ω | | 10 | |
| General | | | | |
| Protective measures | – | Overload, short-circuit, and ground fault protection | | |
| Line filter in accordance with EN 61800-3 | – | Category C3 | | |
| Cooling | – | Integrated fan | | |
| Mounting | – | Wall-mounted on backplate using backlink connector | | |
| Weight | kg | 6 | | |
| Dimensions (W x H x D) | mm | 137.3 x 406.3 x 270 | | |

1) An external brake resistor can be connected.

11.2.4 Characteristic Data for Decentral Access Module (DAM 510)

Table 157: Characteristic Data for DAM 510

| Definition | Unit | Power size 1 | Power size 2 |
|--|-----------|--|----------------|
| Input | | | |
| DC link | V DC | 565–680 \pm 10% | |
| DC-link capacitance | μ F | 660 | |
| Maximum input current | A DC | 15 | 25 |
| U_{AUX} | V DC | 24/48 \pm 10% | |
| U_{AUX} current consumption at 24 V DC | A DC | 0.5 | |
| U_{AUX} current consumption at 48 V DC | A DC | 0.3 | |
| Output | | | |
| Output voltage | V DC | $V_{OUT PSM}$ | |
| Output current DC link | A DC | 15 | 25 |
| Peak current DC link (rms value) $t < 1.0$ s | A_{rms} | 30 for < 1 s | 48 for < 1 s |
| Output current U_{AUX} | A DC | 15 | |
| General | | | |
| Protective measures | – | Overload, short-circuit, and ground fault protection | |
| Cooling | – | Natural convection | |
| Mounting | – | Wall-mounted on backplate using backlink connector | |
| Weight | kg | 3.05 | |
| Dimensions (W x H x D) | mm | 84.3 x 471 x 270 | |

11.2.5 Characteristic Data for Auxiliary Capacitors Module (ACM 510)

Table 158: Characteristic Data for ACM 510

| Definition | Unit | Value |
|---|------|--|
| DC link | V DC | 565–680 ±10% |
| DC-link capacitance | µF | 2750 |
| U _{AUX} | V DC | 24/48 ±10% |
| U _{AUX} current consumption at 24 V DC | A DC | 0.5 |
| U _{AUX} current consumption at 48 V DC | A DC | 0.3 |
| Cooling | – | Natural convection |
| Mounting | – | Wall-mounted on backplate using backlink connector |
| Weight | kg | 3.54 |
| Dimensions (W x H x D) | mm | 84 x 371 x 270 |

11.2.6 Characteristic Data for Expansion Module (EXM 510)

Table 159: Characteristic Data for Expansion Module (EXM 510)

| Definition | Unit | Value |
|------------------------|------|--|
| DC link | V DC | 565–680 ±10% |
| Maximum current | A DC | 62 |
| Mounting | – | Wall-mounted on backplate using backlink connector |
| Weight | kg | 0.6 |
| Dimensions (W x H x D) | mm | 87 x 380 x 145 |

11.3 Dimensions

11.3.1 Dimensions of ISD 520 Servo Drive

All dimensions are in mm [in].

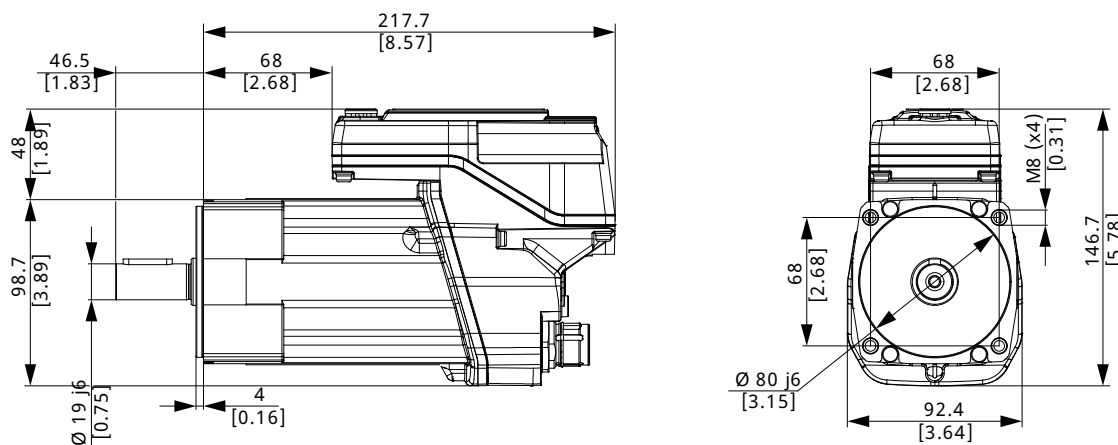
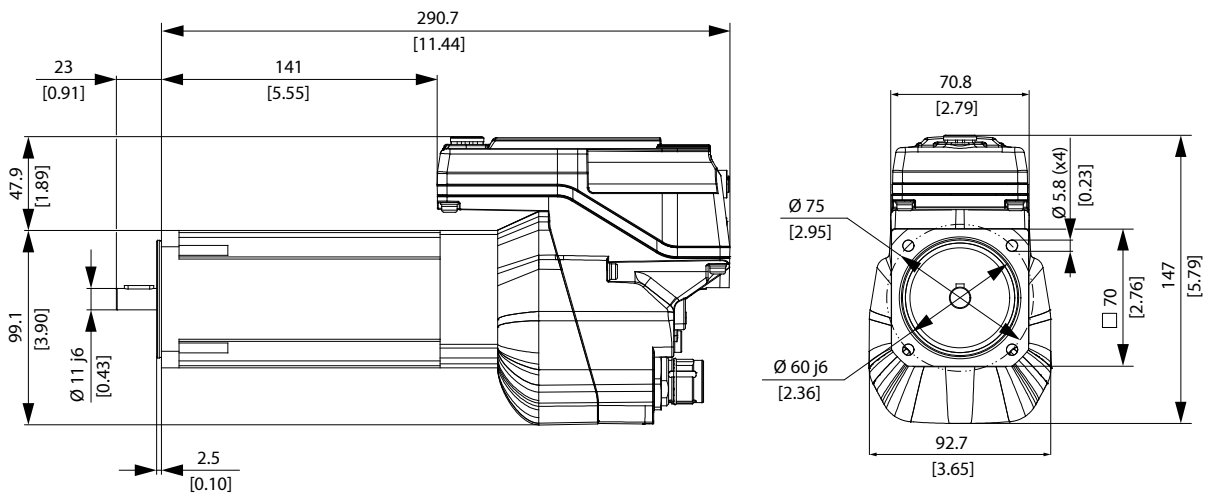
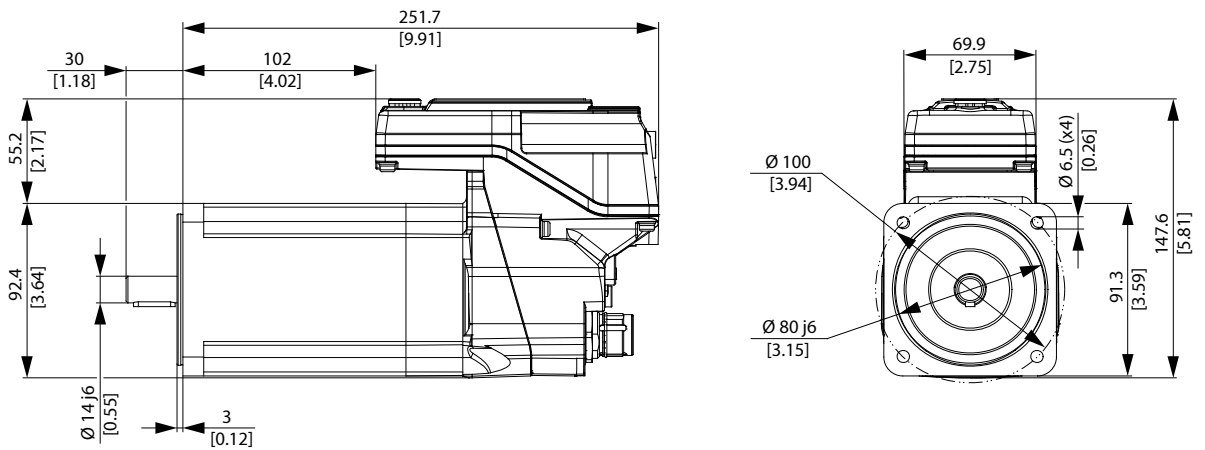

Figure 114: Dimensions of ISD 520, Size 1, E0



e30b1123.10

Figure 115: Dimensions of ISD 520, Size 1, E1



e30b1110.10

Figure 116: Dimensions of ISD 520, Size 2

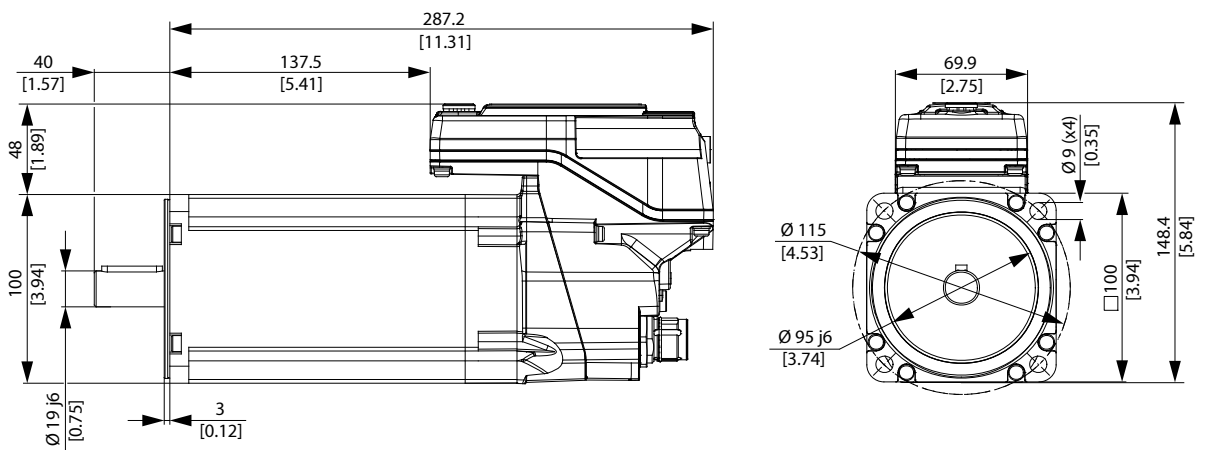

e30b1111.10

Figure 117: Dimensions of ISD 520, Size 3

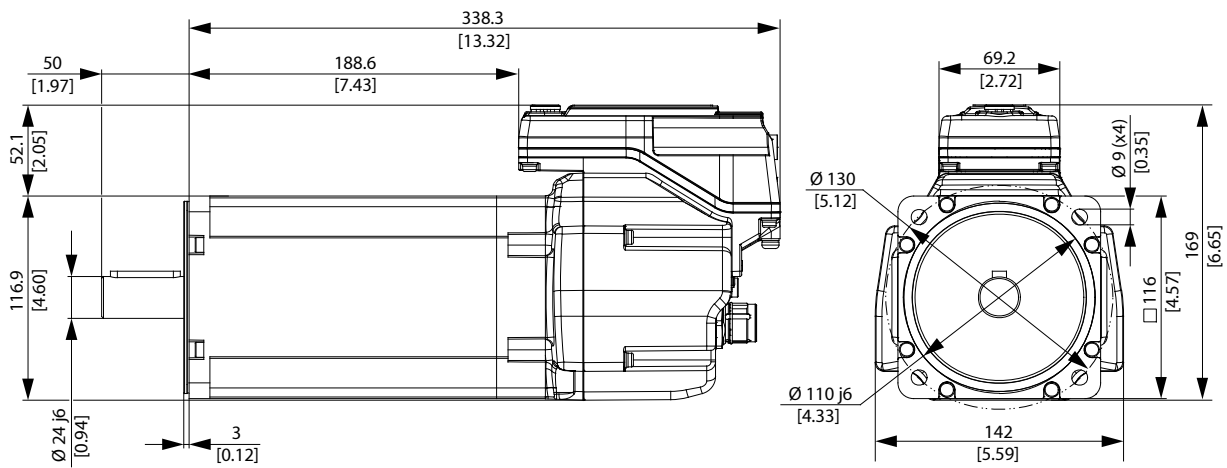

e30b112.10

Figure 118: Dimensions of ISD 520, Size 4

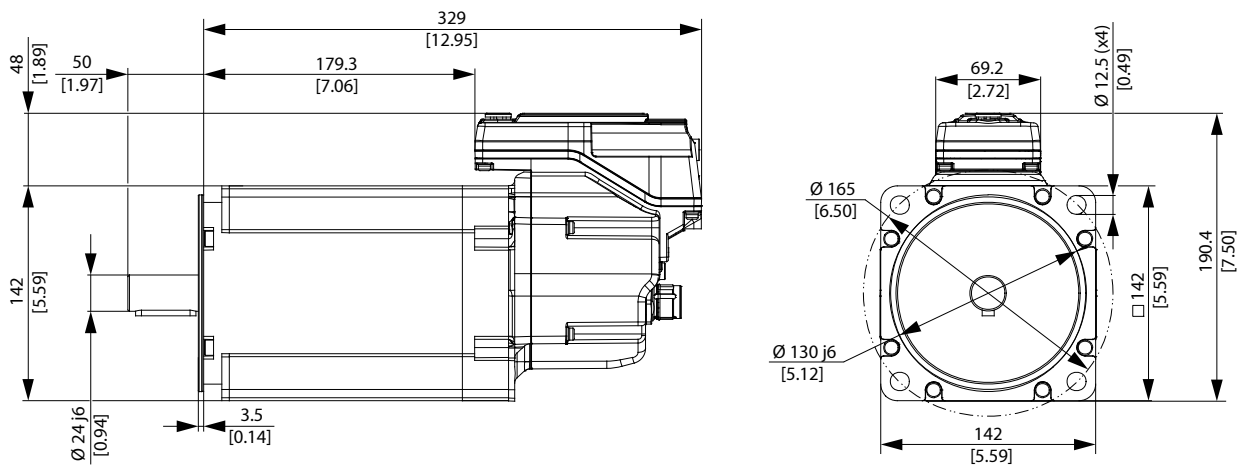

e30b113.10

Figure 119: Dimensions of ISD 520, Size 5

11.3.2 Dimensions of DSD 520 Servo Drive

All dimensions are in mm [in].

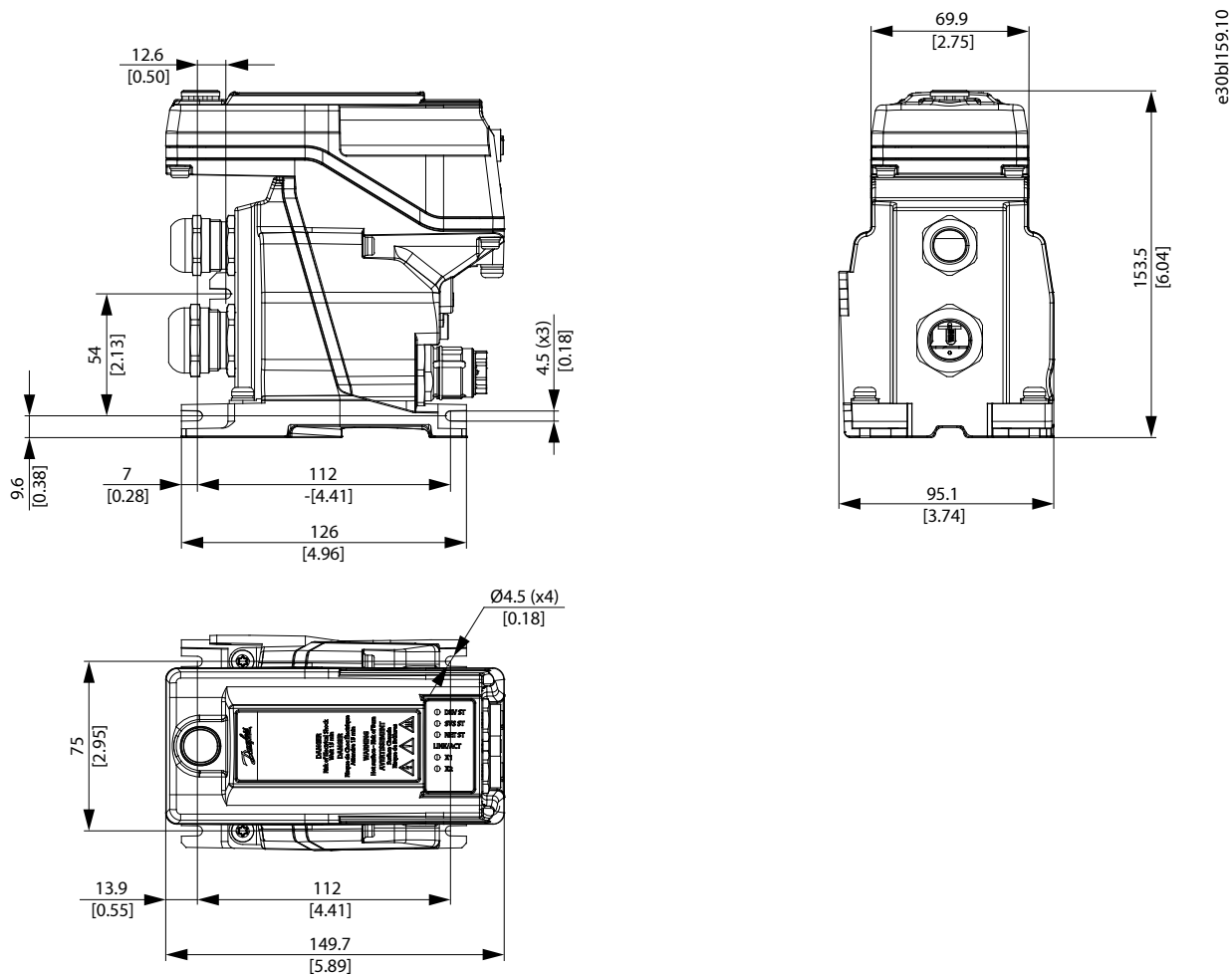

e30bl159.10

Figure 120: Dimensions of DSD 520

11.3.3 Dimensions of Power Supply Module (PSM 510)

All dimensions are in mm [in].

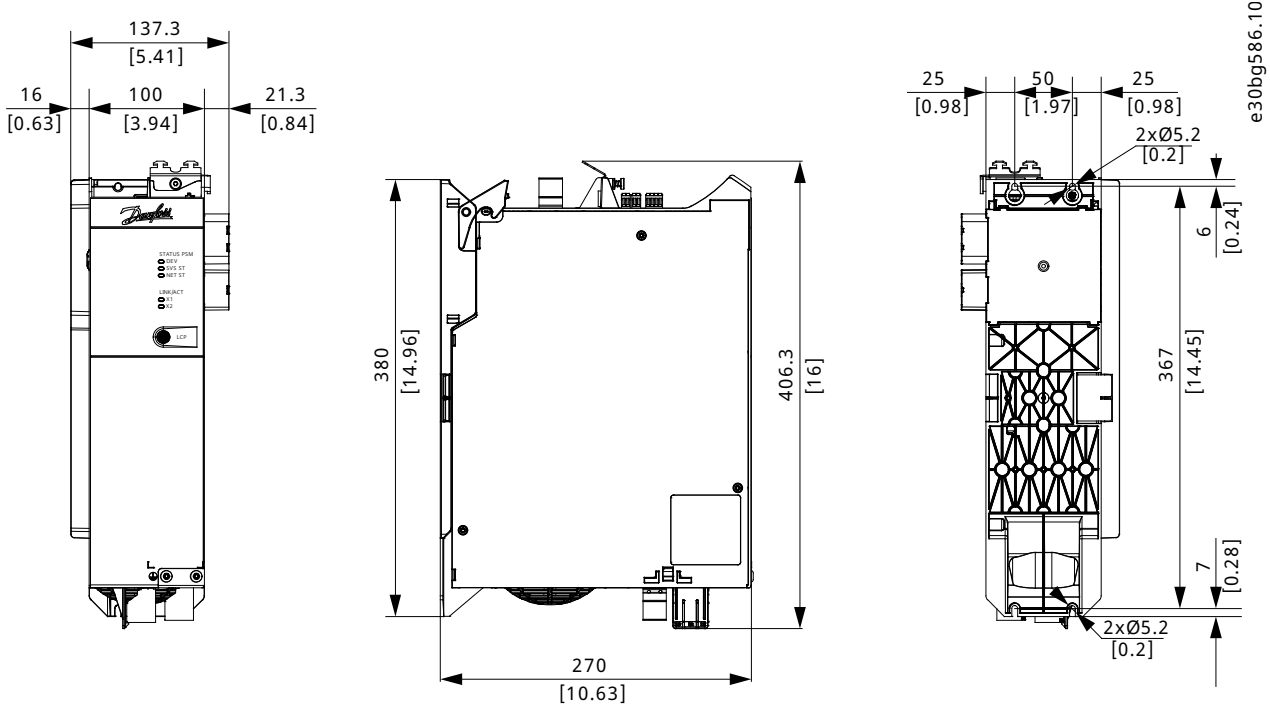

Figure 121: Dimensions of PSM 510

11.3.4 Dimensions of Decentral Access Module (DAM 510)

All dimensions are in mm [in].

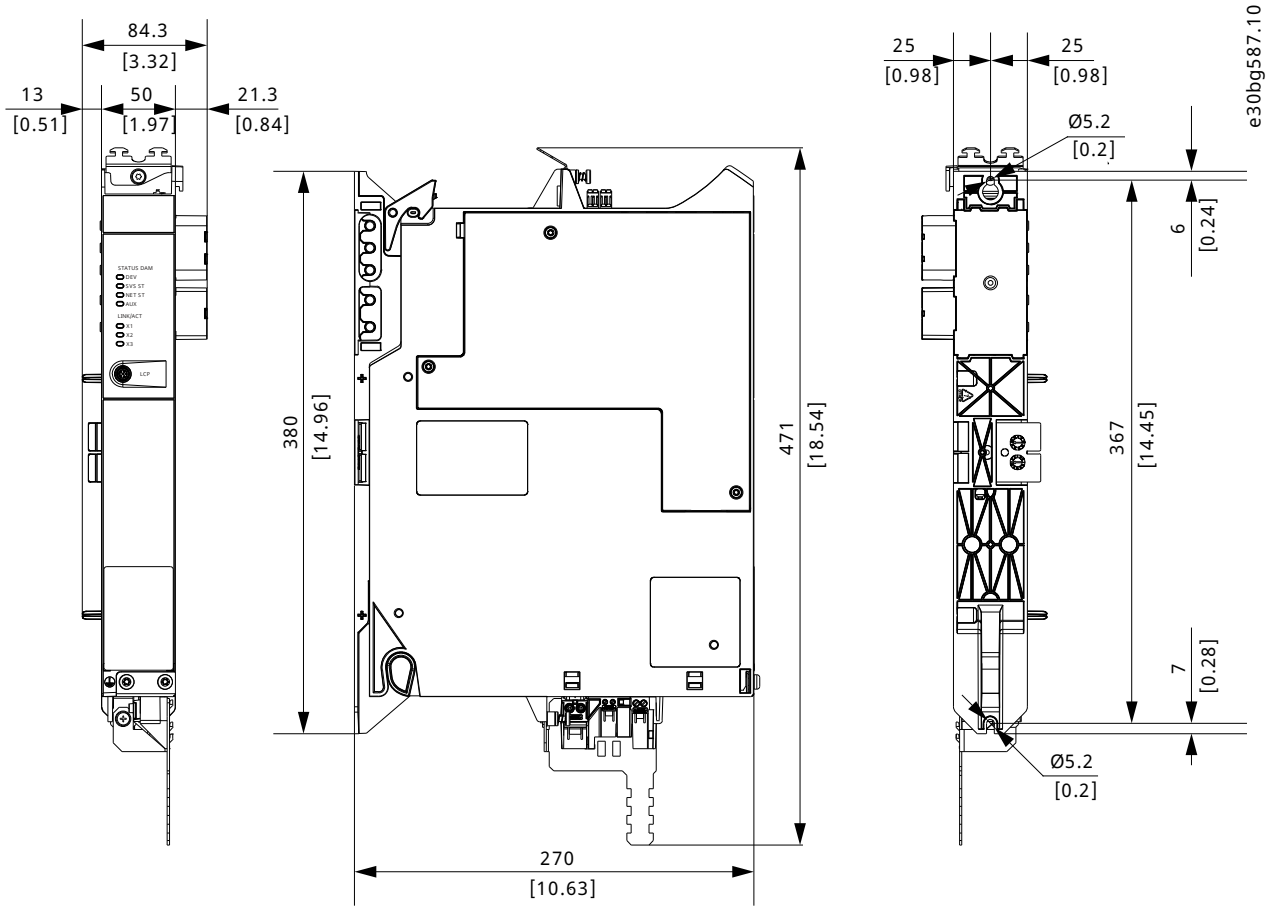

Figure 122: Dimensions of DAM 510

11.3.5 Dimensions of Auxiliary Capacitors Module (ACM 510)

All dimensions are in mm [in].

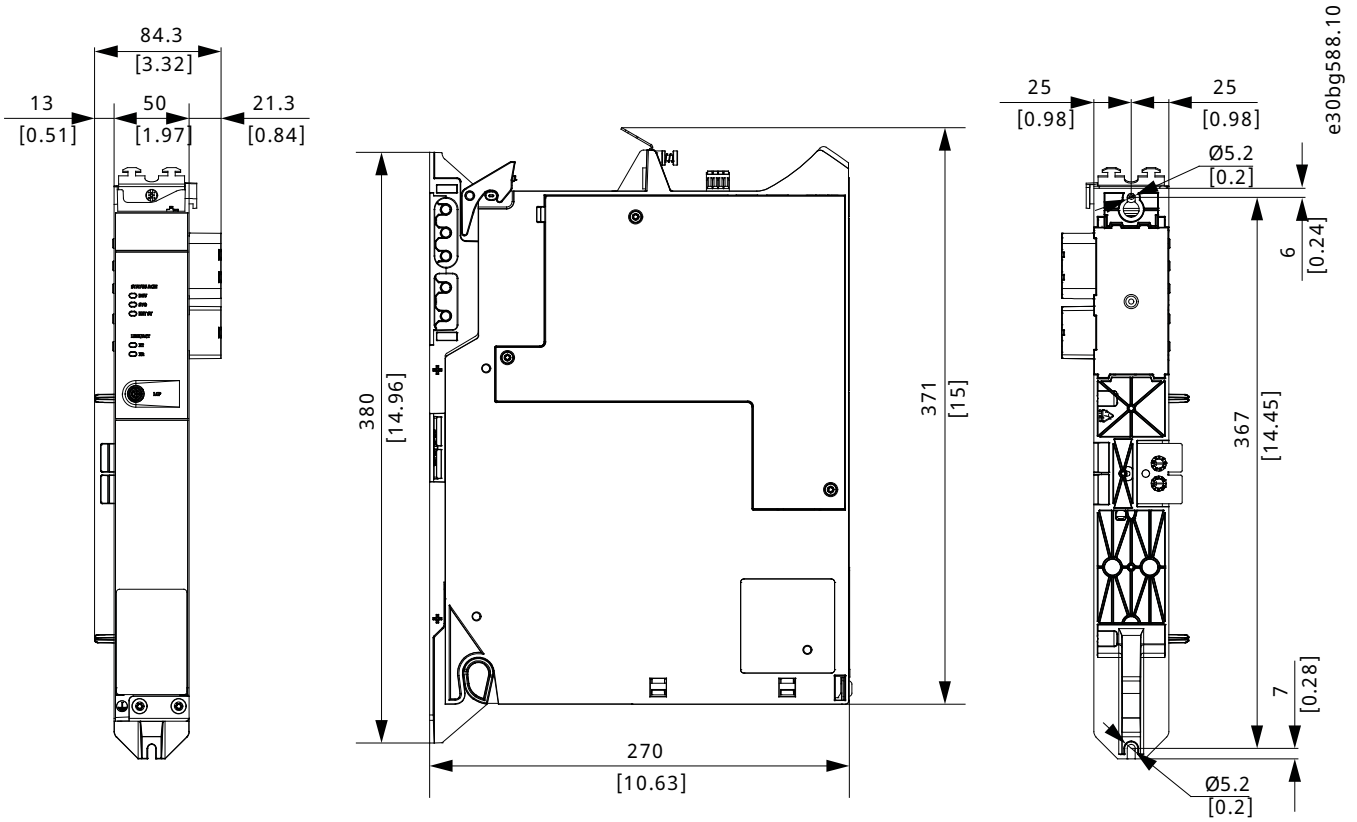

Figure 123: Dimensions of ACM 510

11.3.6 Dimensions of Expansion Module (EXM 510)

All dimensions are in mm [in].

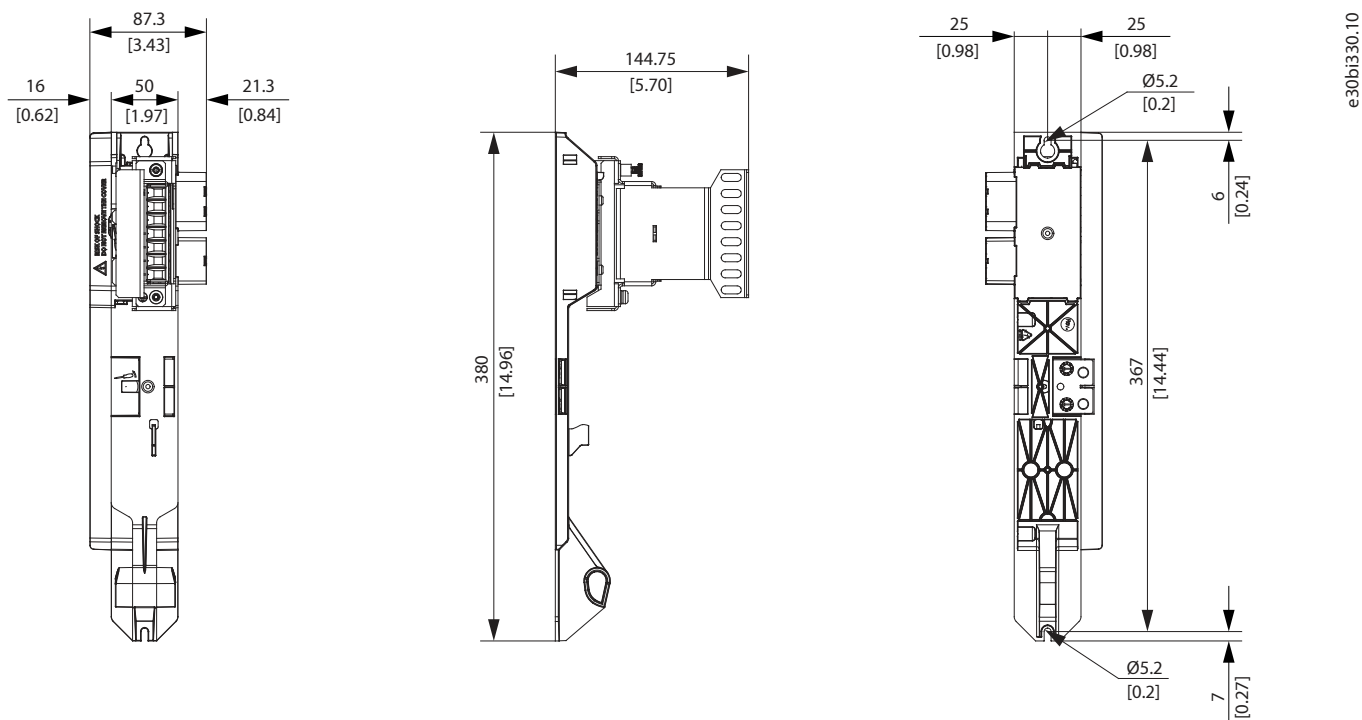

Figure 124: Dimensions of EXM 510

11.4 Motor Overload Protection

| NOTICE | |
|---|--|
| <ul style="list-style-type: none"> Internal motor overload protection operates at 120% of the motor full load current. Instruct DSD 520 with nominal motor current (full load current according to the motor technical label) to use the protection properly. | |

ISD 520/DSD 520 servo drives incorporate internal overload protection in the following multiples of current setting:

Table 160: Multiples of Current Setting

| Multiple of current setting | Maximum trip time |
|-----------------------------|-------------------|
| 7.2 | 20 seconds |
| 1.5 | 8 minutes |
| 1.2 | 2 hours |

11.5 Motor Overtemperature Protection

The internal motor overload protection implemented does not have thermal memory retention or speed sensitivity.

| NOTICE | |
|--|--|
| <ul style="list-style-type: none"> A temperature sensor is integrated in ISD 520. Internal motor overtemperature protection is not incorporated in DSD 520, so motor overtemperature sensing is required. DSD 520 has an input for motor temperature sensor. | |

11.6 Allowed Forces on the ISD 520 Servo Drive Shaft

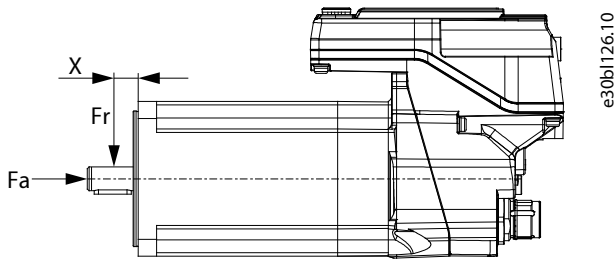

Figure 125: Allowed Forces

The maximum axial and radial load, while assembling the motor and for any mechanical device connected to the shaft, must not exceed the values specified (see [11.2.1 Characteristic Data for ISD 520 Servo Drive](#)). The shaft must be loaded slowly and in a constant manner: Avoid pulsating loads.

NOTICE

- The bearing could be permanently damaged if the maximum allowed forces are exceeded.
- Avoid axial loads on the motor shaft. Axial loading significantly shortens the life of the motor.

11.7 Connectors on the ISD 520/DSD 520 Servo Drives

11.7.1 X1 and X2 Hybrid Connectors

The hybrid cable provides the supply (mains and auxiliary), the communication lines, and the safety supply for each line of servo drives. Input and output connectors are connected inside the servo drive.

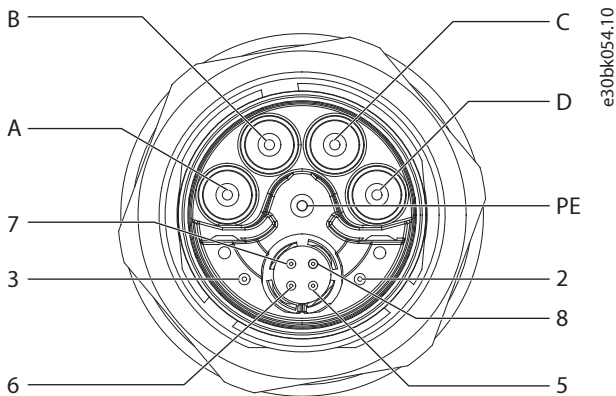

Figure 126: Pin Assignment of X1 Male Hybrid Connector (M23)

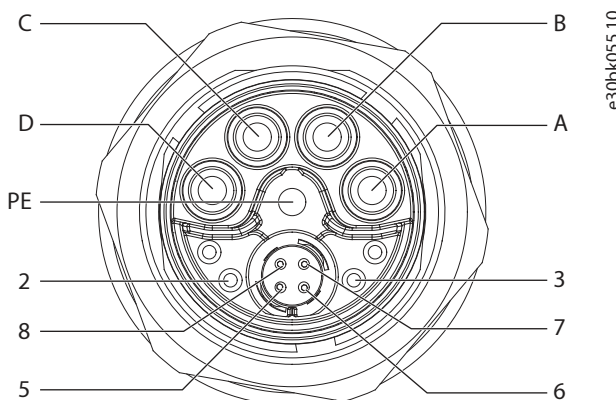

Figure 127: Pin Assignment of X2 Female Hybrid Connector (M23)

Table 161: Pin Assignment of X1 and X2 Hybrid Connectors (M23)

| Pin | Description | Notes | Rating/parameter |
|-----|-------------|----------------------------|---|
| A | UDC- | Negative DC supply | Operating voltage: 565–680 V DC, maximum 778 V Negative DC supply (maximum –15 A/25 A) |
| B | UDC+ | Positive DC supply | Operating voltage: 565–680 V DC, maximum 778 V Positive DC supply (maximum 15 A/25 A) |
| C | AUX+ | Auxiliary supply | 24–48 V DC ±10%, 15 A |
| D | AUX- | Auxiliary supply ground | Absolute maximum 55 V DC |
| PE | PE | PE connector | 15 A |
| 2 | STO+ | Safety supply | 24 V DC ±10%, 1 A |
| 3 | STO- | Safety supply ground | |
| 5 | TD+ | Positive Ethernet transmit | According to standard 100BASE-T |
| 6 | RD- | Positive Ethernet receive | |
| 7 | TD- | Negative Ethernet transmit | |
| 8 | RD+ | Negative Ethernet receive | |

11.7.2 X3: I/O Connector (M12, 8 pole)

The X3 connector is available on the ISD 520/DSD 520 servo drives, when equipped with an option board. Depending on the type of option board it can be configured as:

- Digital output
- Digital input
- 24 V supply
- Additional fieldbus port (X3)

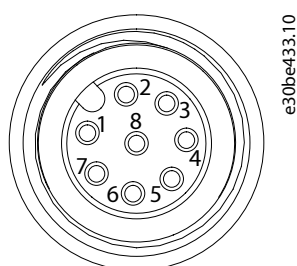

Figure 128: X3 I/O Connector for Channel A

Table 162: Pin Assignment of X3 Safe I/O Connector for Channel A

| Pin | Description | Notes | Rating/parameter |
|-----|-------------|---------------------|---|
| 1 | IN 1A | Input 1, channel A | See 11.10 Safe Digital Inputs and Outputs . |
| 2 | GND 1 | GND for input 1 | |
| 3 | IN 1B | Input 1, channel B | |
| 4 | 24 V | 24 V output | |
| 5 | GND | GND | |
| 6 | OUT 1A | Output 1, channel A | |
| 7 | OUT 1B | Output 1, channel B | |
| 8 | GND | GND | |

Table 163: Pin Assignment of X3 Standard I/O Connector

| Pin | Description | Notes | Rating/parameter |
|-----|-------------|---|---|
| 1 | DO 2 | Switched 24 V as digital output or supply (24 V/150 mA) | Nominal voltage: 24 V \pm 15% Maximum current: 150 mA Maximum switching frequency: 100 Hz |
| 2 | GND | Ground | – |
| 3 | DI 1 | Digital input 1 | Nominal voltage: 0–24 V Bandwidth: \leq 100 kHz |
| 4 | TD– | Negative Ethernet transmit | According to standard 100BASE-T |
| 5 | RD+ | Positive Ethernet receive | According to standard 100BASE-T |
| 6 | TD+ | Positive Ethernet transmit | According to standard 100BASE-T |
| 7 | DI 2 | Digital input 2 | Nominal voltage: 0–24 V Bandwidth: \leq 100 kHz |
| 8 | RD– | Negative Ethernet transmit | According to standard 100BASE-T |

11.7.3 X4: I/O Connector (M12, 8 pole)

The X4 connector is available on the ISD 520/DSD 520 servo drives when equipped with an option board. Depending on the type of option board it can be configured as:

- Digital output
- Digital input
- 24 V supply
- Analog input
- External encoder interface (SSI or BiSS)

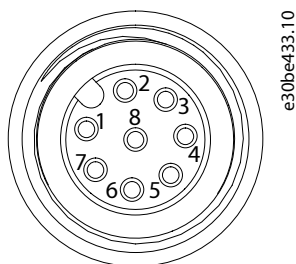

Figure 129: X4 I/O Connector for Channel B

Table 164: Pin Assignment of X4 Safe I/O Connector for Channel B

| Pin | Description | Notes | Rating/parameter |
|-----|-------------|---------------------|---|
| 1 | IN 2 A | Input 2, Channel A | See 11.10 Safe Digital Inputs and Outputs . |
| 2 | GND2 | GND for input 1 | |
| 3 | IN 2 B | Input 2, Channel B | |
| 4 | 24 V | 24 V output | |
| 5 | GND | GND | |
| 6 | OUT 2 A | Output 2, Channel A | |
| 7 | OUT 2 B | Output 2, Channel B | |
| 8 | GND | GND | |

Table 165: Pin Assignment of X4 Standard I/O Connector

| Pin | Description | Notes | Rating/parameter |
|-----|-------------|---|---|
| 1 | DO 1 | Switched 24 V as digital output or supply (24 V/150 mA) | Nominal voltage: 24 V \pm 15% Maximum current: 150 mA Maximum switching frequency: 100 Hz |
| 2 | GND | Ground | – |
| 3 | AI 1 | Analog input 1 (voltage) | Nominal voltage: 0–24 V Bandwidth: \leq 25 kHz |
| 4 | CLK– | External encoder negative clock signal | Protocol: BiSS, SSI |
| 5 | DATA+ | External encoder positive data signal | Protocol: BiSS, SSI |
| 6 | CLK+ | External encoder positive clock signal | Protocol: BiSS, SSI |
| 7 | AI 2 | Analog input 2 (current) | Nominal current: 0–20 mA Bandwidth: \leq 25 kHz |
| 8 | DATA– | External encoder negative data signal | Protocol: BiSS, SSI |

11.7.4 X5: LCP Connector (M8, 6 pole)

The X5 connector is used to connect the LCP directly to the ISD 520/DSD 520 servo drives via a cable.

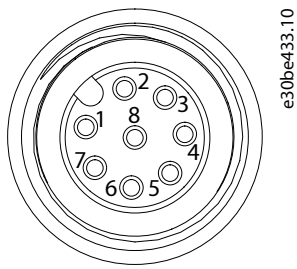

e30be433.10

Figure 130: Pin Assignment of X5 LCP Connector (M8, 6 Pole)

Table 166: Pin Assignment of X5 LCP Connector

| Pin | Description | Notes | Rating/parameter |
|-----|---------------|-----------------------|---|
| 1 | Not connected | – | – |
| 2 | /LCP RST | Reset | Active at $\leq 0.5\text{ V}$ |
| 3 | LCP RS485 | Positive RS485 signal | Speed: 38.4 kBd The levels fulfill the RS485 specification. |
| 4 | /LCP RS485 | Negative RS485 signal | |
| 5 | GND | GND | – |
| 6 | VCC | 5 V supply for LCP | 5 V $\pm 10\%$ at 120 mA maximum load |

11.8 Connectors on the DSD 520 Servo Drives

11.8.1 Digital Motor Feedback Connector

Table 167: Pin Assignment for Digital Motor Feedback Connector

| Pin | Description | Rating/parameter |
|-------|-------------------------------|---------------------------|
| VCC | Encoder supply | +5 V/+11 V ⁽¹⁾ |
| GND | Ground | – |
| DATA+ | Encoder positive data signal | – |
| DATA– | Encoder negative data signal | – |
| CLK+ | Encoder positive clock signal | – |
| CLK– | Encoder negative clock signal | – |

1) The supply switches automatically between 5 V and 11 V depending on which feedback type is selected.

The conductor cross-section range is 0.2–1.5 mm², solid or flexible (AWG 24–AWG 16).

NOTICE

- Only PELV potential can be connected to the digital motor feedback connector.

11.8.2 Analog Motor Feedback Connector

Table 168: Pin Assignment for Analog Motor Feedback Connector

| Pin | Description | Rating/parameter |
|-----|----------------------------------|------------------|
| EX+ | Resolver positive exciter output | – |
| EX– | Resolver negative exciter output | – |

Table 168: Pin Assignment for Analog Motor Feedback Connector - (continued)

| Pin | Description | Rating/parameter |
|------|--------------------------------|------------------|
| SIN+ | Resolver positive sine input | – |
| SIN– | Resolver negative sine input | – |
| COS+ | Resolver positive cosine input | – |
| COS– | Resolver negative cosine input | – |

The conductor cross-section range is 0.2–1.5 mm², solid or flexible (AWG 24–AWG 16).

| NOTICE | |
|--|--|
| <ul style="list-style-type: none"> Only PELV potential can be connected to the analog motor feedback connector. | |

11.8.3 Thermistor, Mechanical Brake, and HIPERFACE® DSL Connector

Table 169: Pin Assignment for Thermistor, Mechanical Brake, and HIPERFACE® DSL Connector

| Pin | Description | Notes | Rating/parameter |
|-------|------------------------------------|--|--|
| DSL+ | HIPERFACE® DSL positive line | – | – |
| DSL– | HIPERFACE® DSL negative line | – | – |
| TEMP+ | Temperature sensor, positive input | Used to connect the motor's temperature sensor (if present). | KTY83–110 KTY84–130 PT1000 |
| TEMP– | Temperature sensor, negative input | | |
| BRK+ | Mechanical brake, positive | Used to connect the motor's mechanical brake (if present). | Nominal voltage: 24 V Maximum (peak) voltage: 48 V ±10% Maximum brake current: 2.5 A |
| BRK– | Mechanical brake, negative | | |

The conductor cross-section range is 0.2–1.5 mm², solid or flexible (AWG 24–AWG 16).

| NOTICE | |
|---|--|
| <ul style="list-style-type: none"> Only PELV potential can be connected to the thermistor, mechanical brake, and HIPERFACE® DSL connector. | |

11.8.4 Motor Phase Connector

Table 170: Pin Assignment for Motor Phase Connector

| Pin | Description | Rating/parameter |
|-----|---------------|---|
| U | Motor phase U | Nominal voltage: 400–480 V ±10% (see 11.2.2 Characteristic Data for DSD 520 Servo Drive) |
| V | Motor phase V | |
| W | Motor phase W | |

The conductor cross-section range is 0.2–4 mm², solid or flexible (AWG 24–AWG 12).

11.8.4.1 Cable Cross-sections for the Motor Phases

Table 171: Cable Cross-sections for the Motor Phases

| Description | Value |
|--|---------------------|
| Minimum cable cross-section for CE (minimum 70 °C, Cu) | 1.5 mm ² |
| Minimum cable cross-section for UL (minimum 60 °C, Cu) | 14 AWG |

11.9 Connectors on the System Modules

11.9.1 Backlink Connector

The backlink connector is at the top of the backside of all the system modules.

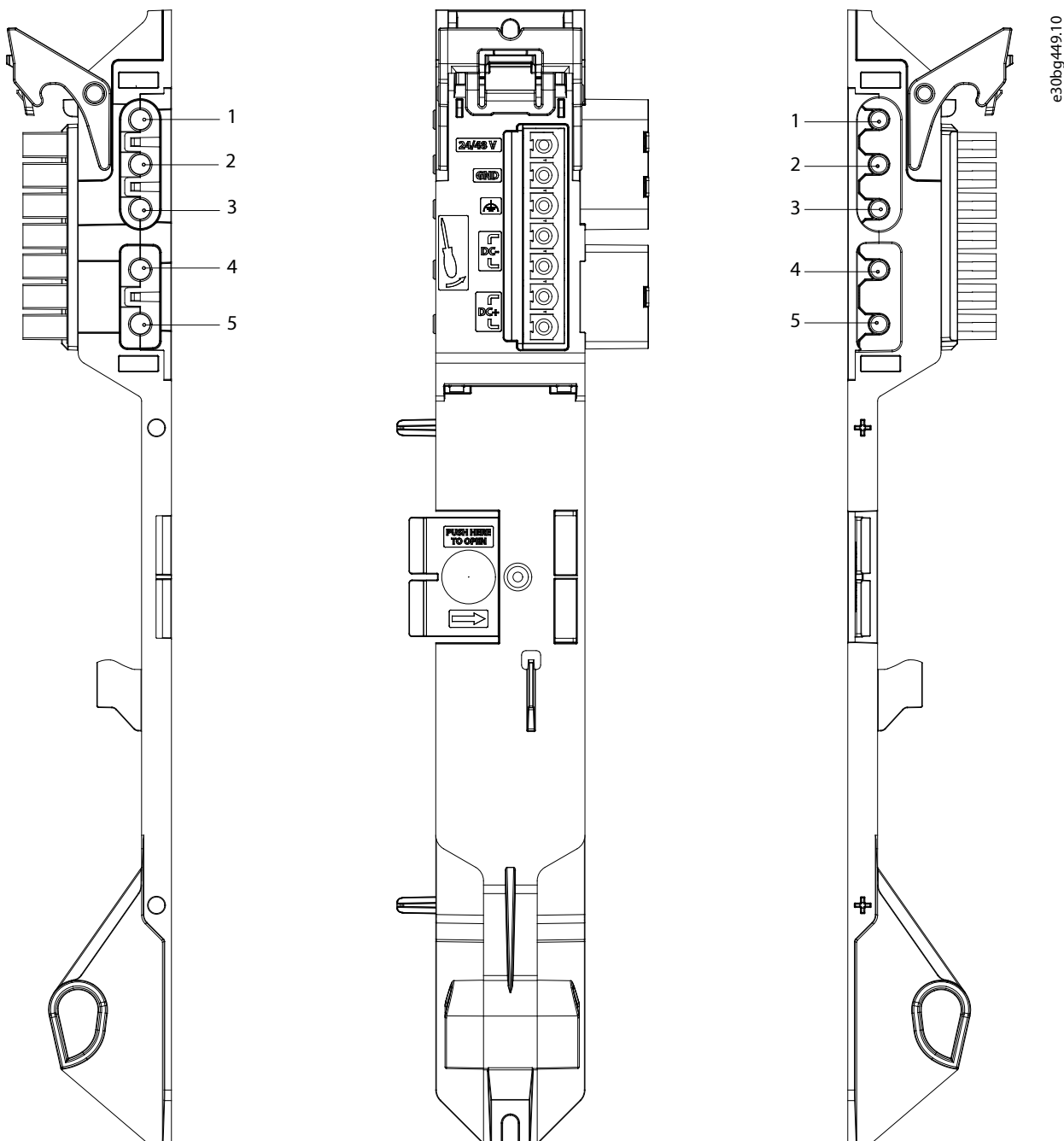

Figure 131: Pin Assignment of Backlink Connector

Table 172: Pin Assignment of Backlink Connector

| Pin | Description |
|-----|----------------------|
| 1 | 24/48 V |
| 2 | GND |
| 3 | FE: Functional earth |
| 4 | DC- |
| 5 | DC+ |

11.9.2 Brake Connectors

There are brake connectors on the Power Supply Module (PSM 510).

11.9.2.1 Brake Resistor Connector on PSM 510

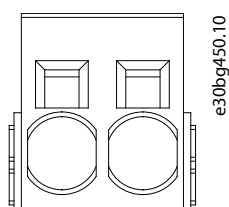

Figure 132: Brake Connector on PSM 510

Table 173: Pin Assignment of Brake Connector on PSM 510

| Pins (left to right) | Pins (left to right) | Notes | Ratings |
|----------------------|----------------------|---------------------------------------|---|
| 1 | DC+/R+ | Used for connecting a brake resistor. | Nominal voltage: 565–800 V DC Maximum brake current: 80 A Conductor cross-section range: 0.75–16 mm ² (AWG 18–AWG 4) |
| 2 | R- | | |

NOTICE

- The maximum length of the brake cable is 30 m (shielded).

11.9.3 Ethernet Connectors

There are Ethernet connectors on all the system modules.

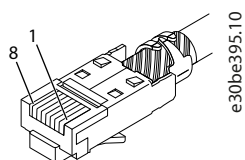

Figure 133: Ethernet Connector

NOTICE

- Only PELV potential can be connected to the digital inputs and outputs.

11.9.3.1 Ethernet Connectors on PSM 510 and ACM 510

Table 174: Ethernet Connectors on PSM 510 and ACM 510

| Connector name | Description | Pins | Ratings |
|----------------|---------------|--------|----------------------------------|
| X1 IN | Ethernet IN | 1: TX+ | According to standard 100BASE-T. |
| X2 OUT | Ethernet OUT1 | 2: TX- | |
| | | 3: RX+ | |
| | | 4: - | |
| | | 5: - | |
| | | 6: RX- | |
| | | 7: - | |
| | | 8: - | |

11.9.3.2 Ethernet Connectors on DAM 510

Table 175: Ethernet Connectors on DAM 510

| Connector name | Description | Pins | Ratings |
|----------------|--|--------|----------------------------------|
| X1 IN | Ethernet IN | 1: TX+ | According to standard 100BASE-T. |
| X2 OUT | Ethernet OUT1 (connection to hybrid cable) | 2: TX- | |
| | | 3: RX+ | |
| X3 OUT | Ethernet OUT2 | 4: - | |
| | | 5: - | |
| | | 6: RX- | |
| | | 7: - | |
| | | 8: - | |

11.9.4 I/O Connectors

11.9.4.1 I/O Connector on PSM 510/ACM 510

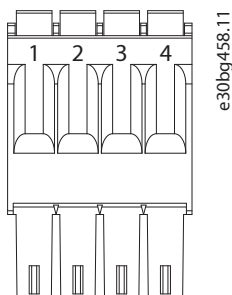

Figure 134: I/O Connector on PSM 510 (I/O PSM) and ACM 510 (I/O ACM)

Table 176: Pin Assignment of I/O Connector on PSM 510/ACM 510

| Pins | Description | Notes | Rating/parameter |
|------|-------------|----------------|--|
| 1 | DIN1- | Digital input | Galvanic isolated Input voltage: 0–30 V DC High (logic "1") voltage: 15–30 V DC Low (logic "0") voltage: <5 V DC Maximum input signal frequency: 50 Hz Maximum input current at 48 V: 11 mA Maximum input resistance: 4.5 KΩ |
| 2 | DIN1+ | | |
| 3 | DIG_OUT- | Digital output | Galvanic isolated Maximum voltage between terminals: 24 V DC or AC Maximum current: 1 A Maximum output switching frequency: 50 Hz |
| 4 | DIG_OUT+ | | |

The conductor cross-section range is 0.2–1.5 mm² (AWG 24–AWG 16).

NOTICE

- Only PELV potential can be connected to the digital inputs and outputs.

11.9.5 UAUX Connector

The U_{AUX} connector is on the Power Supply Module (PSM 510).

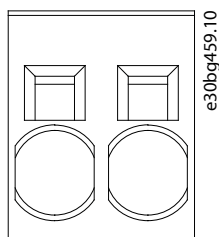

Figure 135: U_{AUX} Connector

Table 177: Pin Assignment of U_{AUX} Connector

| Pins (left to right) | Description | Notes | Rating/parameter |
|-------------------------|-------------|---|---|
| 1 | 24 V AUX | Used for 24–48 V DC input to the Power Supply Module (PSM 510). | Nominal input voltage: 24 V/48 V DC ±10% Maximum current: 50 A Maximum cross-section: 16 mm ² Maximum cable length: 3 m Conductor cross-section range 0.75–16 mm ² , solid or flexible (AWG 18–AWG 4) |
| 2 | GND | | |

NOTICE

- Only PELV potential can be connected to the U_{AUX} input.

⚠ CAUTION

POSSIBLE LOSS OF FUNCTIONAL SAFETY PROTECTION

The functional safety feature may be affected if the U_{AUX} input exceeds 60 V.

- Ensure that the U_{AUX} input remains below 60 V.

11.9.5.1 24/48 V Cable Cross-sections for PSM 510

Table 178: 24/48 V Cable Cross-sections for PSM 510

| Description | Value |
|--|--------------------|
| Minimum cable cross-section for CE (minimum 70 °C, Cu) | 16 mm ² |
| Minimum cable cross-section for UL (minimum 60 °C, Cu) | 4 AWG |

11.9.6 LCP Connector (M8, 6 Pole)

There is an LCP connector on the front of all the system modules. It is used to connect the LCP directly via a cable.

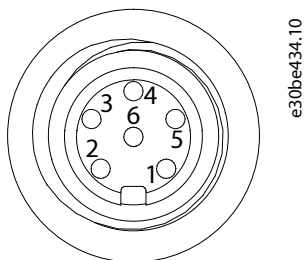

Figure 136: LCP Connector (M8, 6 Pole)

Table 179: Pin Assignment of LCP Connector

| Pins | Description | Notes | Rating/parameter |
|------|---------------|-------|------------------|
| 1 | Not connected | – | – |
| 2 | /LCP RST | Reset | Active at ≤0.5 V |

Table 179: Pin Assignment of LCP Connector - (continued)

| Pins | Description | Notes | Rating/parameter |
|------|-------------|-----------------------|---|
| 3 | LCP RS485 | Positive RS485 signal | Speed: 38.4 kBd The levels fulfill the RS485 specification. |
| 4 | /LCP RS485 | Negative RS485 signal | |
| 5 | GND | GND | – |
| 6 | VCC | 5 V supply for LCP | 5 V \pm 10% at 120 mA maximum load |

NOTICE

- Only PELV potential can be connected to the LCP input.

11.9.7 AC Mains Connector

The AC mains connector is on the bottom of the Power Supply Module (PSM 510).

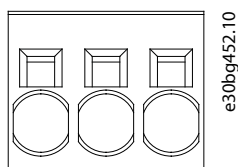

Figure 137: AC Mains Connector

Table 180: Pin Assignment of AC Mains Connector

| Pins (left to right) | Description | Notes | Rating/parameter |
|-------------------------|-------------|--------------------------|--|
| 1 | L3 | Used to connect L1/L2/L3 | Nominal voltage: 400–480 V AC \pm 10% Nominal power: 30 kW Maximum cross-section: 16 mm ² (AWG 4) Conductor cross-section range 0.75–16 mm ² , solid or flexible (AWG 18–AWG 4) |
| 2 | L2 | | |
| 3 | L1 | | |

11.9.7.1 Mains Cable Cross-sections for PSM 510

Table 181: Mains Cable Cross-sections for PSM 510

| | PSM 510 (10 kW) | PSM 510 (20 kW) | PSM 510 (30 kW) |
|------------------------------------|--|---|---|
| Minimum cable cross-section for CE | 4 mm ² (minimum 70 °C, Cu) | 16 mm ² (minimum 70 °C, Cu) | 16 mm ² (minimum 90 °C, Cu) |
| Minimum cable cross-section for UL | AWG 10 (minimum 60 °C, Cu) | AWG 6 (minimum 60 °C, Cu) | AWG 4 (minimum 75 °C, Cu) |

11.9.8 Relay Connector

NOTICE

- Only PELV potential can be connected to the relay outputs.

11.9.8.1 Relay Connector on PSM 510/ACM 510

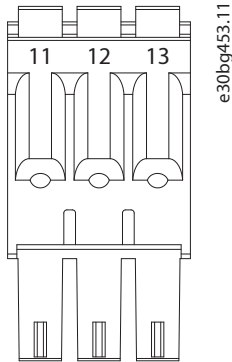

Figure 138: Relay Connector on PSM 510/ACM 510

Table 182: Pin Assignment of Relay Connector on PSM 510 (REL PSM) and ACM 510 (REL ACM)

| Pins | Description | Notes | Rating/parameter |
|------|-------------|--------------------------|---|
| 11 | NC | Normally closed, 24 V DC | Nominal current: 2 A Conductor cross-section range: 0.2–1.5 mm ² (AWG 24–AWG 16) |
| 12 | NO | Normally open, 24 V DC | |
| 13 | COM | Common | |

11.9.9 STO Connectors

11.9.9.1 STO Connectors on PSM 510

There is 1 input and 1 output STO connector on the Power Supply Module (PSM 510).

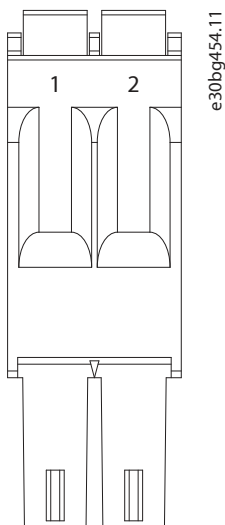

Figure 139: STO Output Connector on PSM 510

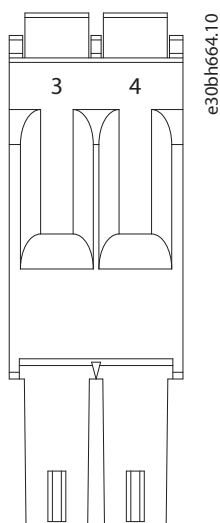

Figure 140: STO Input Connector on PSM 510

Table 183: Pin Assignment of STO Connectors on PSM 510

| Connector name | Pins | Description | Notes | Rating/parameter |
|----------------|------|-------------|---|---|
| STO PSM | 1 | STO- | Used for STO output voltage to the input of the other system modules. | Nominal voltage: 24 V DC $\pm 10\%$ Nominal current: Depends on the number of servo drives in the application. Maximum current: 1 A Conductor cross-section range: 0.2–1.5 mm ² (AWG 24–AWG 16) |
| | 2 | STO+ | | |
| | 3 | STO- | Used for STO input voltage. | |
| | 4 | STO+ | | |

NOTICE

- Only PELV potential can be connected to the STO inputs.

11.9.9.2 STO Connectors on DAM 510

11.9.9.2.1 STO Connectors on the Top of DAM 510

There is 1 input and 1 output STO connector on the top of the Decentral Access Module (DAM 510).

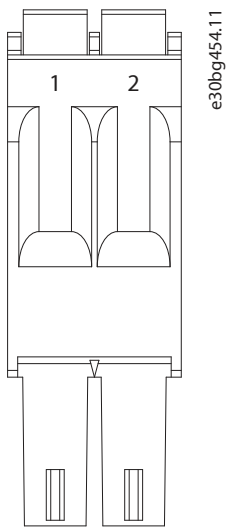

Figure 141: STO Output Connector on the Top of DAM 510

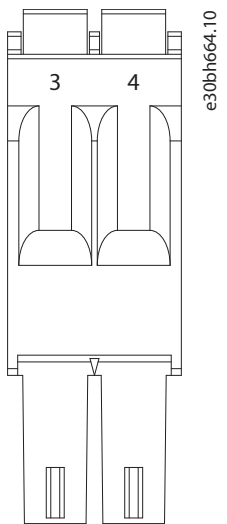

Figure 142: STO Input Connector on the Top of DAM 510

Table 184: Pin Assignment of STO Connectors on the Top of DAM 510

| Connector name | Pins | Description | Notes | Rating/parameter |
|----------------|------|-------------|---|---|
| STO DAM | 1 | STO- | Used for STO output voltage to the input of the other system modules. | Nominal voltage: 24 V DC $\pm 10\%$ Nominal current: Depends on the number of servo drives in the application. Maximum current: 1 A Conductor cross-section range: 0.2–1.5 mm ² (AWG 24–AWG 16) |
| | 2 | STO+ | | |
| | 3 | STO- | Used for STO input voltage. | |
| | 4 | STO+ | | |

NOTICE

- Only PELV potential can be connected to the STO inputs.

11.9.9.2.2 STO Connector on the Bottom of DAM 510

There is 1 output STO connector on the bottom of the Decentral Access Module (DAM 510). The output is for the hybrid cable.

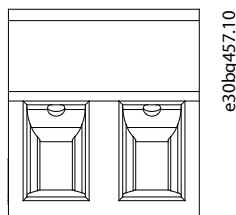

Figure 143: STO Connector on the Bottom of DAM 510

Table 185: Pin Assignment of STO Connector on the Bottom of DAM 510

| Connector name | Pins (left to right) | Description | Notes | Rating/parameter |
|----------------|----------------------|-------------|---|---|
| STO DAM | 1 | STO+ | Used for the STO output from the DAM to the hybrid cable. | Nominal voltage: 24 V DC \pm 10% Nominal current: Depends on the number of servo drives in the application. Maximum current: 1 A Conductor cross-section range: 0.2–1.5 mm ² (AWG 24–AWG 16) Plug terminal tightening torque: 0.22–0.25 Nm (1.95–2.21 in-lb) |
| | 2 | STO– | | |

11.9.10 UDC Connector

The UDC connector is on the bottom of the Decentral Access Module (DAM 510).

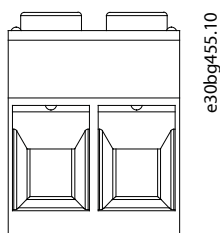

Figure 144: UDC Connector

Table 186: Pin Assignment of UDC Connector

| Pins (left to right) | Description | Notes | Rating/parameter |
|-------------------------|-------------|--|---|
| 1 | UDC+ | Used to connect the DC-link voltage from the Decentral access Module (DAM 510) to the hybrid cable for the ISD line. | Nominal voltage: 565–800 V DC Nominal current: Depends on the number of servo drives in the application. Maximum current: 25 A Conductor cross-section range: 0.2–6 mm ² (AWG 24–AWG 10) Plug terminal tightening torque: 0.5–0.8 Nm (4.43–7.08 in-lb) |
| 2 | UDC– | | |

11.9.11 AUX Connector

The AUX connector is on the bottom of the Decentral Access Module (DAM 510).

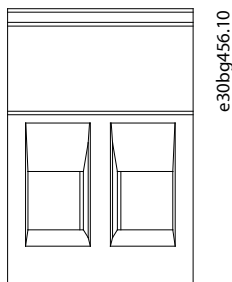

Figure 145: AUX Connector

Table 187: Pin Assignment of AUX Connector

| Pins (left to right) | Description | Notes | Rating/parameter |
|-------------------------|----------------|---|--|
| 1 | AUX+ (24/48 V) | Used to connect the AUX output from the Decentral access Module (DAM 510) to the hybrid cable for the line of drives. | Nominal voltage: 24/48 V DC ±10% Nominal current: Depends on the number of servo drives in the application. Maximum current: 15 A Conductor cross-section range: 0.2–2.5 mm ² (AWG 24–AWG 12) Plug terminal tightening torque: 0.5–0.6 Nm (4.43–5.31 in-lb) |
| 2 | AUX– (GND) | | |

NOTICE

- Only PELV potential can be connected to the AUX output.

11.9.12 External Encoder Connectors

This connector is used to connect an external encoder to DAM 510. It provides a guide value for CAM mode and Gear mode. The external encoder connector is located on the Decentral Access Module (DAM 510) as follows:

- DAM 510: E DAM

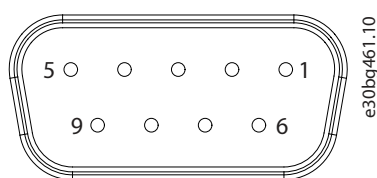

Figure 146: External Encoder Connector

Table 188: External Encoder Connectors

| Connector name | Description | Pins | Ratings/Notes |
|----------------|--|---------------------------------|---|
| E DAM | Used to connect the external encoder to DAM 510. | See Table 189 . | Nominal voltage: 24 V DC, isolated (see Table 189) Nominal current: Depends on the number of servo drives in the application. Maximum current: 150 mA (see Table 189) Fulfill the following specifications: <ul style="list-style-type: none"> BISS/SSI |

Table 189: Pin Assignment of External Encoder Connectors (X1/X2)

| Pins | Description | Notes SSI/BISS | Notes |
|------|-------------|--|---|
| 1 | 24 V | 24 V DC $\pm 10\%$ (used for powering the encoder) | Maximum current: 150 mA |
| 2 | – | – | – |
| 3 | – | – | – |
| 4 | RS422 RXD | Positive data | Bus speed: SSI: Up to 10 Mhz clock frequency with 30 m cable. BiSS: Fulfills the RS485 specification. |
| 5 | RS422 TXD | Positive data | |
| 6 | GX | Isolated ground. If encoders are powered externally, the ground of the external supply must be connected to GX. | – |
| 7 | – | – | – |
| 8 | /RS422 RXD | Negative data | Bus speed: SSI: 0.5 Mbit with 25 m cable. BiSS: Fulfills the RS485 specification. |
| 9 | /RS422 TXD | Negative data | |

NOTICE

- Only PELV potential can be connected to the external encoder.

11.9.13 Expansion Module Connector

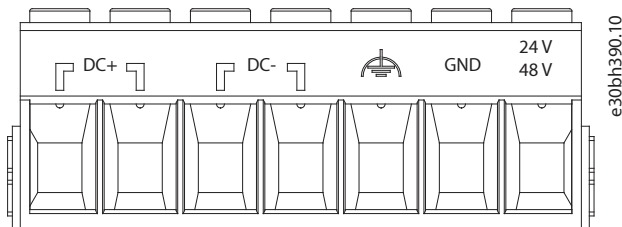

Figure 147: Expansion Module Connector

Table 190: Pin Assignment of Expansion Module Connector

| Pins (left to right) | Description | Note | Rating/parameter |
|----------------------|-----------------------|--|---|
| 1 | DC+ | Shield the DC cables using the cable tie on the EXM 510 EMC plate. | Nominal voltage: 565–800 V DC Nominal current: Depends on the number of servo drives in the application. Maximum current: 62 A ⁽¹⁾ |
| 2 | | | |
| 3 | DC– | | |
| 4 | | | |
| 5 | FE (functional earth) | – | Conductor cross-section range: 0.75–16 mm ² , solid or flexible (AWG 18–AWG 4) Only use with ferrule without plastic sleeve with CRIMPFOX 16 S. Use shielded conductors for UDC (DC+, DC–). Plug terminal tightening torque: 1.7–1.8 Nm (15.05–15.93 in-lb) |
| 6 | GND | – | |
| 7 | 24/48 V | – | |

1) The maximum current rating for 1 pair of EXM is 62 A. In systems with 2 PSM 510 modules, 2 pairs of EXM 510 modules can be used to achieve a maximum current rating of 124 A.

11.9.13.1 Cable Cross-sections for EXM 510

Table 191: Minimum Cable Cross-sections for EXM 510 Cables

| Cable | CE | UL |
|---------------------|--|--|
| DC+/DC– | 16 mm ² (minimum 70 °C, Cu) | 6 AWG (minimum 75 °C, Cu) |
| 24 V, functional PE | 16 mm ² (minimum 70 °C, Cu) | 6 AWG (minimum 90 °C, Cu) ⁽¹⁾ |

1) Minimum 75 °C is allowed if less than 45 A is measured on the cable.

11.10 Safe Digital Inputs and Outputs

These safe digital inputs and outputs apply to connectors X3 and X4 when using the Safe I/O option.

Table 192: Digital Input Characteristics Supported by the Safe I/O Board

| Type | Value |
|--|-------------------------|
| Number of safe digital inputs | 4 (2 x dual channel) |
| Nominal input voltage range | 0–24 V DC |
| Input voltage range, logic 0 | 0–5 V DC |
| Input voltage range, logic 1 | >10 V DC |
| Input voltage maximum | 30 V |
| Maximum input current at low level | 5 mA |
| Minimum input current at high level | 1.5 mA |
| Maximum input current at high level | 15 mA |
| Typical input current at high level (24 V) | 3.5 mA |
| Galvanic isolation | Yes |
| Minimum recognition test pulse time | 300 μ s |
| Discrepancy time | Configurable 1–200 ms |
| Filter time | Configurable 2–60 ms |
| Cable length | Maximum 30 m (shielded) |

Table 193: Digital Output Characteristics Supported by the Safe I/O Board

| Characteristic | Value |
|--------------------------------------|-------------------------------------|
| Number of safe digital outputs | 4 (2 x dual channel) ⁽¹⁾ |
| Nominal output voltage high | 24 V DC \pm 15% |
| Nominal output voltage low | <5 V DC |
| Maximum output current at low level | 100 μ A |
| Maximum output current at high level | 100 mA |
| Galvanic isolation | No |
| Short circuit protected | Yes |
| Diagnostic test pulse time | 1 ms |
| Diagnostic test pulse frequency | 1 Hz |
| Cable length | Maximum 30 m (shielded) |

1) The time and frequency of the diagnostic test pulses are not configurable.

11.11 General Specifications and Environmental Data

11.11.1 ISD 520/DSD 520 Servo Drive

Table 194: General Specifications and Environmental Conditions for ISD 520/DSD 520

| Specification | Value |
|--------------------|---|
| Protection ratings | IP65/IP67 according to EN 60529 Type 4X indoor use only See 11.12.1 Protection Ratings for ISD 520 Servo Drive and 11.12.2 Protection Ratings for DSD 520 Servo Drive . |
| Vibration test | Class 3M7 according to IEC 60721-3-3 |

Table 194: General Specifications and Environmental Conditions for ISD 520/DSD 520 - (continued)

| Specification | Value |
|--|--|
| Maximum relative humidity | Storage/transport: 5–95% (non-condensing) |
| | Stationary use: 5–95% (non-condensing) |
| Ambient temperature | Operating: 5–40 °C |
| | Transport: –25 to +55 °C |
| | Storage: –25 to +55 °C |
| Installation altitude | Nominal current up to 1000 m above sea level. Derating of output current (1%/100 m) at 1000–3000 m. Operation above 3000 m is not allowed. |
| EMC standard for emission and immunity | EN 61800-3 (second environment) |
| EMC immunity functional safety | EN 61800-5-2 Annex E |
| Pollution degree | 2 |
| Overvoltage category | III |

11.11.2 System Modules

Table 195: General Specifications and Environmental Conditions for System Modules

| Specification | Value |
|--|---|
| Protection rating | IP20 according to IEC/EN 60529 (except connectors, which are IP00). <div style="border: 1px solid black; padding: 5px; background-color: #fff9c4;"> <p style="text-align: center;"> WARNING</p> <p>RISK OF ELECTRIC SHOCK</p> <p>The IP20 rating of the PSM 510, DAM 510, and ACM 510 modules is not fulfilled if the modules are not connected to the backplate. This may result in death or serious injury.</p> <ul style="list-style-type: none"> Do not touch the backplate when a module is removed from the backplate. </div> |
| Vibration test | Random vibration: 1.14 g (2h/axis according to EN 60068-2-64) |
| | Sinusoidal vibration: 1.0 g (2h/axis according to EN 60068-2-6) |
| Maximum relative humidity | Storage/transport: 5–95% (non-condensing) |
| | Stationary use: 5–93% (non-condensing) |
| Ambient temperature range | Operating: 5–40 °C nominal, up to 55 °C with derating (see Figure 148) |
| | Transport: –25 to +55 °C |
| | Storage: –25 to +55 °C |
| Installation altitude | Nominal current up to 1000 m above sea level. Derating of output current (1% / 100 m at 1000–3000 m). Operation above 3000 m is not allowed. |
| EMC standard for emission and immunity | EN 61800-3 (second environment) |

Table 195: General Specifications and Environmental Conditions for System Modules - (continued)

| Specification | Value |
|--|----------------------|
| EMC immunity for functional safety | EN 61800-5-2 Annex E |
| Degree of pollution according to EN 60664-1 | 2 |
| Overvoltage category according to EN/IEC 61800-5-1 | III |

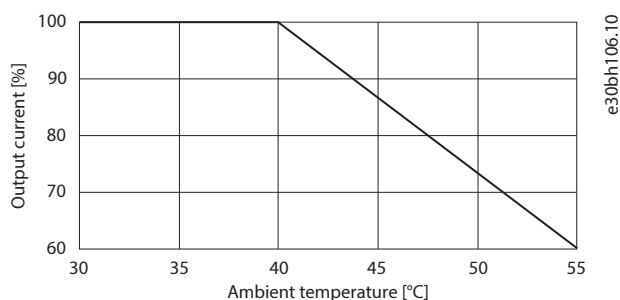

Figure 148: Derating

11.12 Protection Ratings

11.12.1 Protection Ratings for ISD 520 Servo Drive

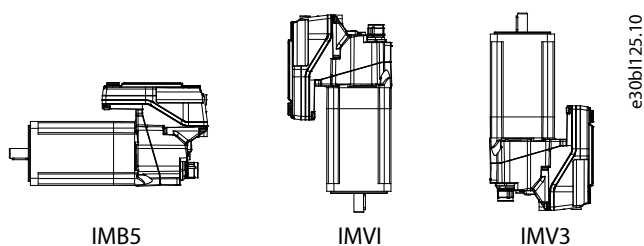

Figure 149: Mounting Positions for ISD 520

Table 196: Protection ratings for ISD 520 Servo Drive

| | Mounting position of servo drive (according to DIN 42 950) | Protection rating (according to EN 60529) |
|---------------------------|--|---|
| Housing (excluding shaft) | All positions | IP67 |
| Shaft with shaft seal | IM B5 & IM V1 | IP65 |
| | IM V3 | IP65 |

NOTICE

- Install and connect the ISD 520 servo drives as described in this guide to achieve the ratings detailed in [Table 196](#) in the final application.

11.12.2 Protection Ratings for DSD 520 Servo Drive

All DSD 520 variants have a protection rating of IP67.

NOTICE

- Install and connect the DSD 520 servo drives as described in this guide to achieve the IP67 rating in the final application.

11.13 Cables

NOTICE

- See the *VLT® Servo Drive System ISD 520, DSD 520, MSD 520 (VLT® FlexMotion™) Design Guide* for cable dimensions and drawings.

11.13.1 Hybrid Cable PE

Table 197: Hybrid Cable PE

| Item | Description | Cross-section |
|-----------------|---|--|
| Hybrid cable PE | Used to connect the PE wire from the hybrid cable to the PE screw on the Decentral Access Module (DAM 510). | Maximum cross-section: 2.5 mm ² /4.0 mm ² |

11.14 Storage

Store the servo system components in a dry, dust-free location with low vibration ($v_{\text{eff}} \leq 0.2$ mm/s).

The storage location must be free from corrosive gases.

Avoid sudden temperature changes.

Long-term storage

To recondition the electrolytic capacitors, servo drives and system components that are not in service must be connected to a supply source once per year to allow the capacitors to charge and discharge. Otherwise the capacitors could suffer permanent damage.

Danfoss A/S
Nordborgvej 81
DK-6430 Nordborg
drives.danfoss.com

.....
Any information, including, but not limited to information on selection of product, its application or use, product design, weight, dimensions, capacity or any other technical data in product manuals, catalog descriptions, advertisements, etc. and whether made available in writing, orally, electronically, online or via download, shall be considered informative, and is only binding if and to the extent, explicit reference is made in a quotation or order confirmation. Danfoss cannot accept any responsibility for possible errors in catalogs, brochures, videos and other material. Danfoss reserves the right to alter its products without notice. This also applies to products ordered but not delivered provided that such alterations can be made without changes to form, fit or function of the product. All trademarks in this material are property of Danfoss A/S or Danfoss group companies. Danfoss and the Danfoss logo are trademarks of Danfoss A/S. All rights reserved.
.....

M00412

