

Installation Instructions

RA2000 Thermostatic Radiator Valve For 2-Pipe Hot Water Applications



Within box:

- RA2000 valve body w/ protective grey cap
- 2pcs. Female solder tailpiece
- 2pcs. Union threaded nut

Note: Thermostatic operator is ordered separately to form a complete assembly. Refer to Thermostatic Operator Selection to determine the correct operator for the installation. As a complete assembly the non-electric regulation of flow is controlled based upon the set ambient air temperature on the operator. Low voltage electronic actuators are available if an electronic option is required.



RA2000 Double Solder Union Valve w/o grey protective cap

Prior to Installation:

The recommended installation location of the valve body is on the supply side of the baseboard or radiator. With the valve on the supply, hot water is controlled from entering into the baseboard or emitter when the set temperature is met. However, if space concern or inaccessibility is an issue the valve body can be installed on the return side.

The orientation of the valve is critical during installation. Stamped onto the body of the valve is an arrow, which indicates the proper flow direction through the valve. If the flow through the valve is incorrect, the result will lead to noise that will be heard during the valve's operation.

Thermostatic Operator Selection (Sold separately):

(013G8250) (013G240) Standard or tamper resistant valve mounted dial and sensor. Must be installed horizontally.	(013G8252) (013G2922) Valve mounted dial and operator with 6ft remote sensor.
(013G8562, 013G8565, 013G8568) Wall mounted dial/sensor and remote operator. Available lengths of 6ft, 16ft, and 26ft.	(013G8564) Wall mounted dial, remote operator and remote sensor. (Two 6ft capillary tubes)

Installation Instructions (baseboard heating shown):

- 1) Measure and cut a section of copper tubing from the existing baseboard to accommodate the valve body assembly (approximately 3" for the 013G8042 and approximately 3-3/8" for the 013G8044).
- 2) Slide the union nuts onto the copper piping (internal threads facing towards the valve body) followed by the solder tailpiece. Solder the tailpieces to the pipe. Note: Do not assemble the valve body when soldering the tailpieces.

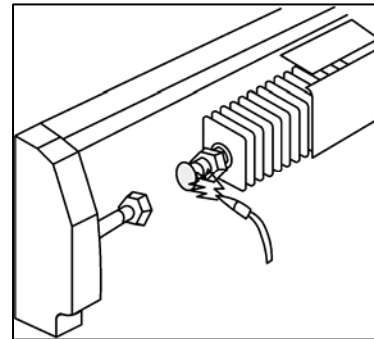
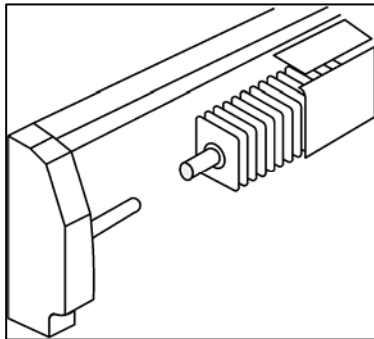

Installation Instructions

RA2000 Thermostatic Radiator Valve For 2-Pipe Hot Water Applications



- 3) Prior to assembling the valve body, orient the valve in the flow direction as seen by the stamped arrow on the valve. Additionally position the gray protective cap either horizontally into the room or vertically toward the ceiling dependent on the selected thermostatic operator. Note: If valve mounted dial and sensor is selected (013G8250) the operator should not be pointing vertically.

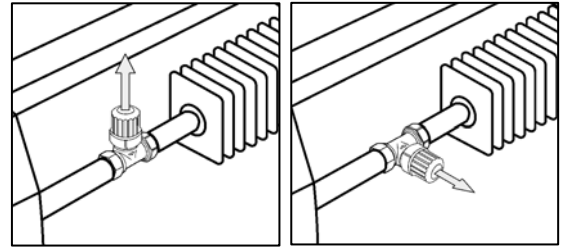

- 4) Remove the grey protective cap from the valve and install the thermostatic operator as per operator's instructions.
- 5) If a valve mounted dial is to be exposed through the panel of the baseboard, locate the exact position of the control dial and drill or punch a 2-3/8" diameter hole.

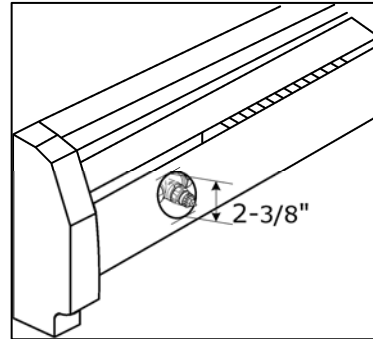
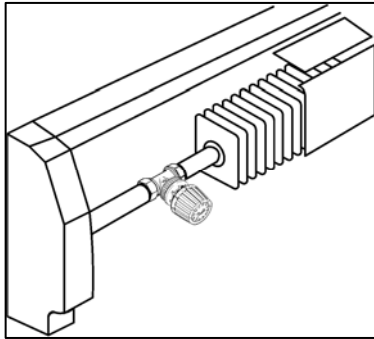

Series to Parallel Piping (3/4" baseboard heating installation example):

The installation of the RA2000 valve body in a series piping (i.e. one baseboard feeds the next baseboard and etc.) can be done to provide individual zoning and control. Additional piping is installed within the baseboard unit to ensure flow downstream is maintained. The following is one method to install the RA2000 valve assembly to create individual control on

a series piped baseboard. The following items are required for the installation:

- 1/2" Copper pipe, length of baseboard
- 2pcs, 1/2" 90° elbows
- 1pc, 1/2" isolation valve
- 2pcs, 3/4" x 3/4" x 1/2" tee

- 1) On the supply side of the radiator, measure and cut a section of baseboard to accommodate the assembly of 3/4" x 3/4" x 1/2" copper tee and RA2000 valve body. In a similar manner on the return side, measure and cut the baseboard to accommodate a 3/4" x 3/4" x 1/2" copper tee.



Supply Side



Return Side

- 2) Preassemble the 1/2" bypass piping to include the 90 elbows and isolation valve within the baseboard enclosure. Tip: If the enclosure is tight, the bypass assembly could be rotated towards the wall to reduce the space required.
- 3) Solder all of the connections together. Note: Do not assemble the valve body when soldering the tailpieces.
- 4) Follow steps 3 & 4 from the Installation Instructions
- 5) If necessary adjust the isolation valve to accommodate for additional resistance through the bypass.



By-pass orientation

Danfoss can accept no responsibility for possible errors in printed materials and reserves the right to alter its products without notice. All trademarks in this material are property of the respective companies. Danfoss and Danfoss logotype are trademarks of Danfoss A/S. All rights reserved.



Head Office:
Danfoss LLC
Mississauga, ON, CANADA L5N 2W3
Tel: 905.285.2050 Fax: 905.285.2055

USA Office:
Danfoss LLC
Baltimore, MD, USA, 21220
Tel: 800.375.4822 Fax: 443.512.0270