

Data sheet

2 - way valve (NC), pressure relieved (PN 25)

VGU - external thread

VGUF- flange

Description



VGU and VGUF are pressure relieved 2-way normally closed (NC) valves, designed to be combined with:

- AVT Temperature actuators
- AMV(E) 20 / AMV(E) 30 electrical actuators
- AMV(E) 23 / AMV(E) 33 electrical actuators with spring return function

In combination with AVT temperature actuators and AMV(E) electrical actuators, valves can be used primarily in cooling systems

Main data:

- DN 15-50
- k_{vs} 4.0 -25 m³/h
- PN 25
- Temperature:
 - Circulation water / glycolic water up to 30%: 2 ...150 °C
- Connections:
 - Ext. thread (weld-on, thread and flange tailpieces)
 - Flange
- Flow and return mounting

Ordering

Example:
Valve NC; DN 15; k_{vs} 4.0; PN 25;
 T_{max} 150 °C; ext. thread

- 1x VGU DN 15 valve
Code No: **065B0791**

Option:
- 1x Weld-on tailpieces
Code No: **003H6908**

VGU, VGUF valve

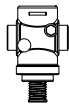
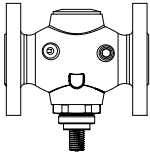
| Picture | DN (mm) | k_{vs} (m ³ /h) | Connection | Code No. |
|---|---------|------------------------------|---|------------------------|
|  | 15 | 4.0 | Cylindrical external thread acc. to ISO 228/1 | G ¾ A 065B0791 |
| | 20 | 6.3 | | G 1 A 065B0792 |
| | 25 | 8.0 | | G 1¼ A 065B0793 |
| | 32 | 12.5 | | G 1¾ A 065B0794 |
| | 40 | 16 | | G 2 A 065B0795 |
| | 50 | 20 | | G 2½ A 065B0796 |
|  | 32 | 12.5 | Flanges PN 25, acc. to EN 1092-2 | 065B0797 |
| | 40 | 20 | | 065B0798 |
| | 50 | 25 | | 065B0799 |

Ordering (continuous)

Accessories

| Picture | Type designation | DN | Connection | Code No. |
|---------|----------------------------|----|--|-------------------|
| | Weld-on tailpieces | 15 | - | 003H6908 |
| | | 20 | | 003H6909 |
| | | 25 | | 003H6910 |
| | | 32 | | 003H6911 |
| | | 40 | | 003H6912 |
| | | 50 | | 003H6913 |
| | External thread tailpieces | 15 | Conical ext. thread acc. to EN 10226-1 | R 1/2 003H6902 |
| | | 20 | | R 3/4 003H6903 |
| | | 25 | | R 1 003H6904 |
| | | 32 | | R 1 1/4 003H6905 |
| | | 40 | | R 1 1/2 065B2004 |
| | | 50 | | R 2 065B2005 |
| | | | | Flange tailpieces |
| 20 | 003H6916 | | | |
| 25 | 003H6917 | | | |
| | Adapter ¹⁾ | | M45 x 1.5 mm / M30 x 1.5 mm | 003H6928 |

¹⁾ Adapter for VGU(F) combinations with electrical actuators type AMV(E) 20, 23, 30, 33.

Technical data

Valves

| Nominal diameter | DN | 15 | 20 | 25 | 32 | 40 | 50 |
|----------------------------------|----------------------|--|-----|--------|--|-------|----|
| k _{vs} value | m ³ /h | 4.0 | 6.3 | 8.0 | 12.5 | 20 | 25 |
| Stroke | mm | 5 | | | | | |
| Control ratio | | >1:50 | | | | | |
| Control characteristic | | linear | | | | | |
| Cavitation factor z | | ≥ 0.6 | | ≥ 0.55 | | ≥ 0.5 | |
| Leakage acc. to standard IEC 534 | % of k _{vs} | ≤ 0.02 | | | ≤ 0.05 | | |
| Nominal pressure | PN | 25 | | | | | |
| Max. differential pressure | bar | 20 | | | 16 | | |
| Media | | Circulation water / glycolic water up to 30% | | | | | |
| Media pH | | Min. 7, max. 10 | | | | | |
| Media temperature | °C | 2 ... 150 | | | | | |
| Connections | valve | External thread | | | External thread and flange | | |
| | tailpieces | Weld-on and external thread | | | | | |
| | | Flange | | | - | | |
| Materials | | | | | | | |
| Valve body | | Red bronze CuSn5ZnPb (Rg5) | | | Ductile iron EN-GJS-400-18-LT (GGG 40.3) | | |
| Valve seat | | Stainless steel, mat. No. 1.4571 | | | | | |
| Valve cone | | Dezincing free brass CuZn36Pb2As | | | | | |
| Sealing | | EPDM | | | | | |
| Pressure relieve system | | Piston | | | | | |

Application principles

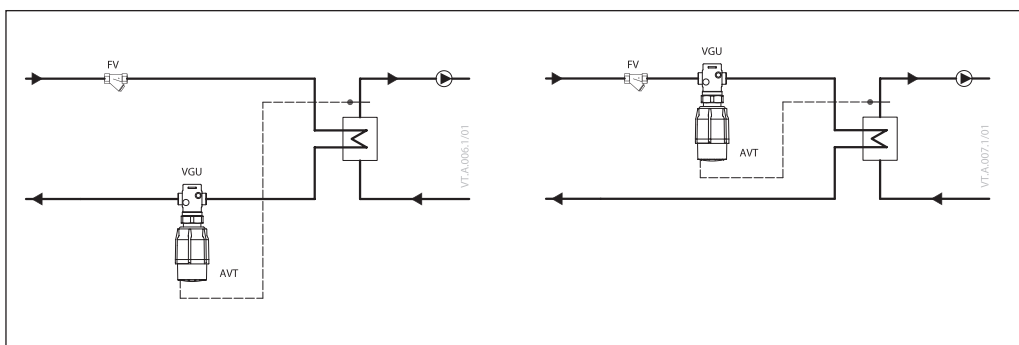

Installation positions

Valves can be installed in any position.

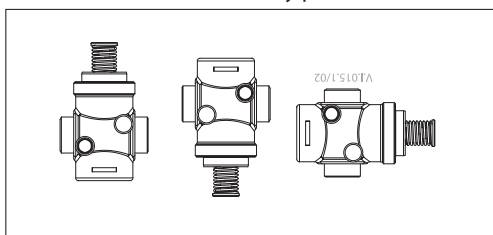

Note!

Installation positions for AVT thermostatic actuator and electrical actuators AMV(E) have to be observed as well. Please see relevant Data sheet

Pressure temperature diagram

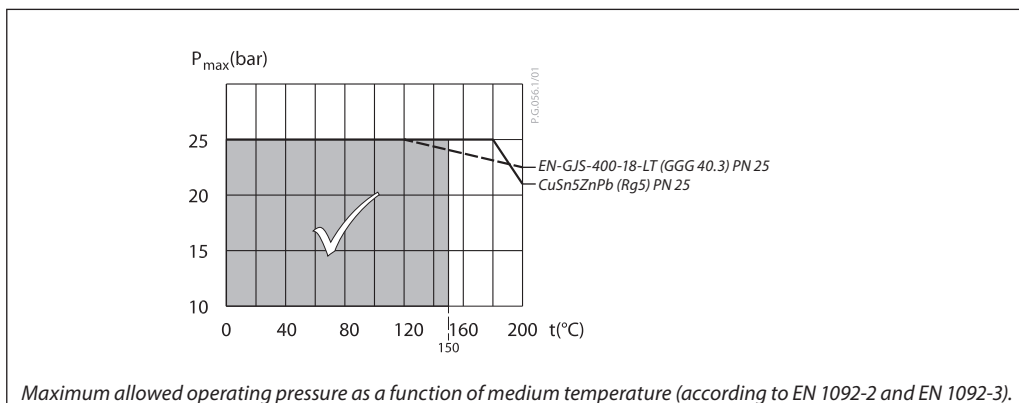

Valve sizing

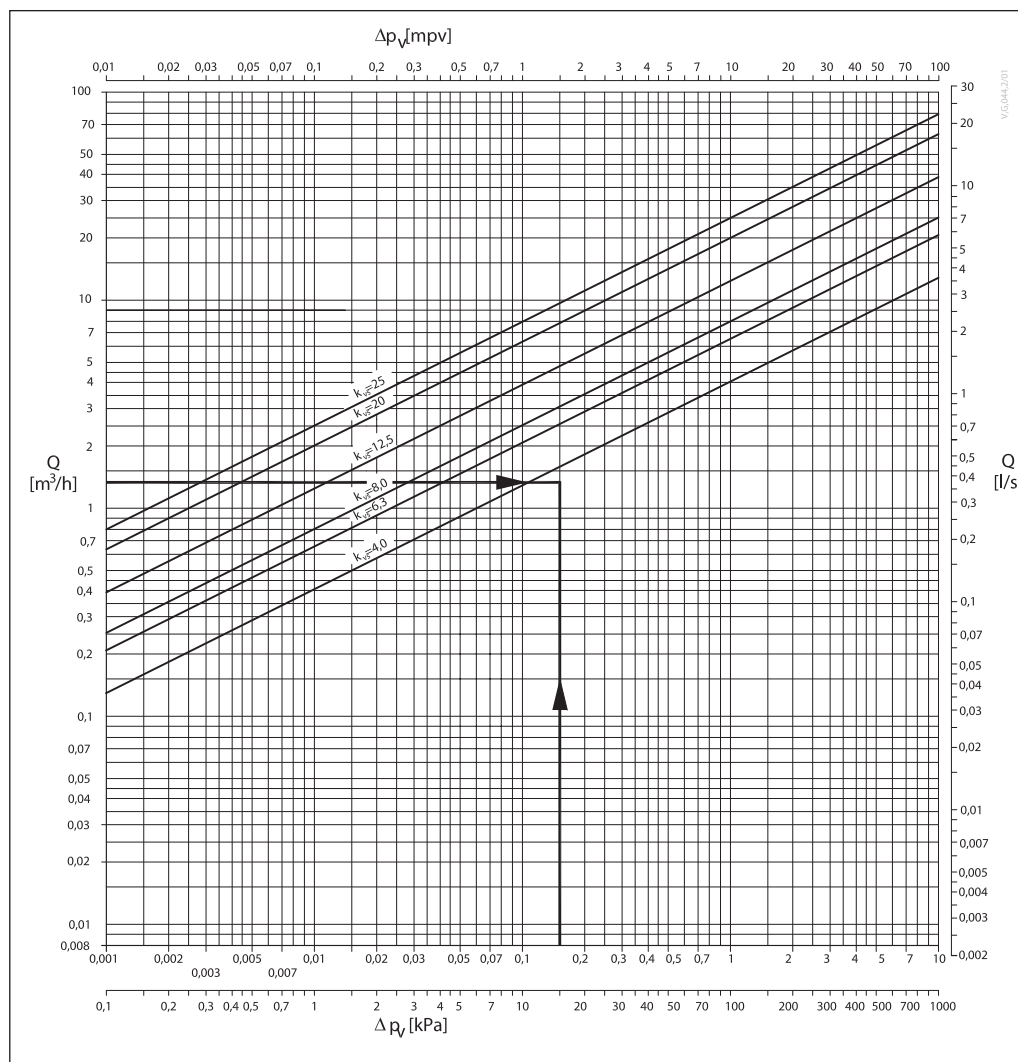

Given data:

$P_{max} = 10 \text{ kW}$
 $\Delta t = 6 \text{ K}$
 $\Delta p_v = 0.15 \text{ bar}$

P_{max} - cooling power (kW)
 Δt - temperature difference (K)
 Δp_v - differential pressure across the valve

Maximum flow Q_{max} (m³/h) through the valve is calculated according to formula:

$$Q_{max} = \frac{P_{max} \times 0.86}{\Delta t} = \frac{10 \times 0.86}{6}$$

$$Q_{max} = 1.43 \text{ m}^3/\text{h}$$

k_v value is calculated according to formula:

$$k_v = \frac{Q_{max}}{\sqrt{\Delta p_v}} = \frac{1.43}{\sqrt{0.15}}$$

$$k_v = 3.7 \text{ m}^3/\text{h}$$

Chosen $k_{vS} = 4.0 \text{ m}^3/\text{h}$

or

read from the sizing diagram by taking a line through Q scale (1.43 m³/h) and Δp_v scale (0.15 bar) to intersect k_v -scale at 3.7 m³/h

Chosen $k_{vS} = 4.0 \text{ m}^3/\text{h}$

Solution:

The example selects ext. thread valve VGU DN 15, k_{vS} value 4.0 .

Design

- 1. Valve body
- 2. Valve insert
- 3. Pressure relieved valve cone
- 4. Valve stem

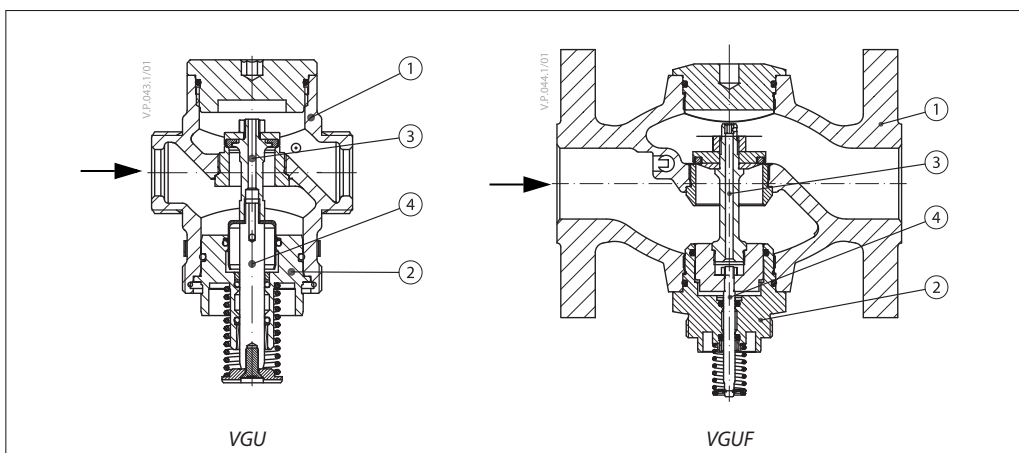

Dimensions

VGU DN 15-25

VGU DN 32-50

VGUF DN 32-50

| DN | L | H | H ₁ | H ₂ | Weight (kg) |
|----|-----|-----|----------------|----------------|-------------|
| | mm | | | | |
| 15 | 65 | 80 | 34 | 46 | 0.7 |
| 20 | 70 | 80 | 34 | 46 | 0.8 |
| 25 | 75 | 83 | 37 | 46 | 0.9 |
| 32 | 100 | 154 | 63 | 91 | 3.2 |
| 40 | 110 | 154 | 63 | 91 | 3.3 |
| 50 | 130 | 154 | 63 | 91 | 4.1 |

| DN | L | H | H ₁ | H ₂ | Weight (kg) |
|----|-----|-----|----------------|----------------|-------------|
| | mm | | | | |
| 32 | 180 | 158 | 70 | 88 | 7.5 |
| 40 | 200 | 163 | 75 | 88 | 9.0 |
| 50 | 230 | 171 | 83 | 88 | 11.1 |

Note: other flange dimensions - see table for tailpieces

VGU L₃, d

VGU L₂, R

VGUF L₁

VGUF n, d₂, k, 45°

| DN | R ¹⁾ | SW | d | L ₁ ²⁾ | L ₂ | L ₃ | k | d ₂ | n |
|----|-----------------|------------|----|------------------------------|----------------|----------------|-----|----------------|---|
| | | mm | | | | | | | |
| 15 | ½ | 32 (G ¾A) | 21 | 130 | 131 | 139 | 65 | 14 | 4 |
| 20 | ¾ | 41 (G 1A) | 26 | 150 | 144 | 154 | 75 | 14 | 4 |
| 25 | 1 | 50 (G 1¼A) | 33 | 160 | 160 | 159 | 85 | 14 | 4 |
| 32 | 1¼ | 63 (G 1¾A) | 42 | - | 177 | 184 | 100 | 18 | 4 |
| 40 | 1½ | 70 (G 2A) | 47 | - | 195 | 204 | 110 | 18 | 4 |
| 50 | 2 | 82 (G 2½A) | 60 | - | 252 | 234 | 125 | 18 | 4 |

Adapter VGU/AMV(E)
M30, 55, M45

¹⁾ Conical ext. thread acc. to EN 10226-1

²⁾ Flanges PN 25, acc. to EN 1092-2



Danfoss A/S

Climate Solutions • danfoss.com • +45 7488 2222

Any information, including, but not limited to information on selection of product, its application or use, product design, weight, dimensions, capacity or any other technical data in product manuals, catalogues descriptions, advertisements, etc. and whether made available in writing, orally, electronically, online or via download, shall be considered informative, and is only binding if and to the extent, explicit reference is made in a quotation or order confirmation. Danfoss cannot accept any responsibility for possible errors in catalogues, brochures, videos and other material. Danfoss reserves the right to alter its products without notice. This also applies to products ordered but not delivered provided that such alterations can be made without changes to form, fit or function of the product.

All trademarks in this material are property of Danfoss A/S or Danfoss group companies. Danfoss and the Danfoss logo are trademarks of Danfoss A/S. All rights reserved.