

Technical Information

Speed and Temperature Sensor

Hydrostatic Propel Products



Revision history*Table of revisions*

Date	Changed	Rev
March 2025	Updated 7-32V table, cleaned up wording	0703
October 2023	Updated 7-32V information, speed ring info, added H1F image	0702
January 2021	Changed document number from 'BC00000047' to 'BC152886482203' and added new speed sensor	0701
January 2020	Added MP1P and MP1M target ring information	0508
November 2019	Corrected speed sensor pinout information.	0507
June 2019	Formula for temperature calculation corrected.	0506
May 2019	Minor update.	0505
February 2018	Minor update.	0504
November 2017	Minor layout changes.	0503
December 2015	Data for size 210 of H1B motor.	0502
2011-2014	Various changes.	BA-FB
Sep 2009	First edition	AA

Contents**General Information**

Description.....	4
Theory of Operation.....	4
Speed Rings.....	4
Temperature Range.....	5
Protection Characteristics.....	5
Mating connectors.....	5
Available Sensors.....	5
Dimensions.....	6
Sensor Installation.....	6

Speed sensor 4.5 – 8 V

Duty Cycles.....	7
Wire Fault Detection.....	8
Output Signals.....	9
Temperature Signal.....	9

Speed Sensor 7 - 32 V

Duty Cycles.....	11
Wire Fault Detection.....	12
Output Signals.....	13
Temperature Signal.....	13

Appendix

MTTFd Values.....	15
-------------------	----

General Information

Description

Function of the speed sensor is to detect the shaft speed. Typically the sensor is mounted to the housing of a Danfoss pump or motor and senses the speed from a target ring that is rotating inside the pump or motor.

Because of the digital output signals for speed the sensor is ideal for high and low speed measurements.

The speed sensor is designed for rugged outdoor, mobile or heavy industrial speed sensing applications.

The detection of the speed is contactless. It is custom-designed for Danfoss. It is a *Plug and Perform* device that does not need any calibration or adjustments.

For diagnostics and other purposes, the sensor also has the capability to detect the driving direction and the case oil temperature.

Theory of Operation

The speed sensor is externally powered and, in response to the speed of the target ring, outputs a digital pulse signal. A magnet inside the sensor provides the magnetic field that changes with the position of the target teeth.

The target ring is attached to the cylinder block or the shaft. Hall-effect sensors change from high/low state as the target teeth pass by the sensor's face. The digital (on-off-on-off) pulse train is fed to a controller, which interprets its rate of change as a speed.

The speed sensor uses two Hall-effect sensors with specific distance and orientation resulting in a pulse train output shift of 90° between the two sensors. A logic circuit decodes the two signals to provide an additional direction indication (high or low depending on direction).

Due to the design of the sensor, the duty cycle (ratio between on and off time at constant speed) of both speed signals at any working condition is close to 50 % and can be used for better resolution at low speeds.

Speed Rings

Speed (target) rings vary according to the diameter of the cylinder block or shaft on which they are installed. The number of teeth is shown in the table below.

The number of speed (target) ring teeth

H1P size	045/053	060/068	069/078	089/100	115/130	147/165/180	210/250/280
Teeth	79	86	86	92	102	108	90

The number of speed (target) ring teeth

H1B and H1F size	060	080	110	160	210	250
Teeth	71	78	86	95	104	108

The number of speed (target) ring teeth

MP1P size	028/032	038/045
Teeth	9	11

The number of speed (target) ring teeth

MP1M size	020/024
Teeth	9

General Information

Target ring for integrated drives

Integrated drive size	IDMV 044	IDMV 053
Number of teeth	75	79

If a product is not seen in the tables, refer to technical information of the specific product.

Temperature Range

Parameter	Minimum	Maximum
Operation temperature range	-40 °C	104 °C

115°C intermittent = short term; t < 1min per incident and not exceeding 2 % of duty cycle based load-life.

Protection Characteristics

Parameter	Data
Protection Code (IP class) according IEC 60529 and DIN 40050	IP 67 (without connector installed) IP 69k (with connector installed)
EMC Emission	EN 61000-6-3
EMC Immunity (EMI)	100 V/m incl. 1 kHz AM 80 %; ISO 11452-5 and -2
ESD	EN 61000-4-2 Air discharge: 15 kV Contact discharge: 8 kV
Vibration	30 G (294 m/s ²)
Shock	50 G (490 m/s ²)
Case maximum pressure	5 bar [72.5 psi]

Mating connectors

There are available two types of mating connectors Assembly Bag DEUTSCH DTM06-6S, Black and Grey.

Ordering number	
11033865	11033863
Assembly Bag, DEUTSCH DTM06-6S-E004; black, (24-20 AWG) 0.21 -0.52 mm ²	Assembly Bag, DEUTSCH DTM06-6S, gray, (24-20 AWG) 0.21 -0.52 mm ²

Available Sensors

There are two speed sensors available according to different supply voltage range: 4.5 to 8 V_{DC} and 7 to 32 V_{DC}.

Description	Order number	
	149055	11232698
Supply voltage	4.5 – 8 V	7 – 32 V
Speed signals	Two, 90° Phase shift	Two, 90° Phase shift
Direction signal	One	One
Temperature signal	One	One

For more information, see below.

General Information

Dimensions

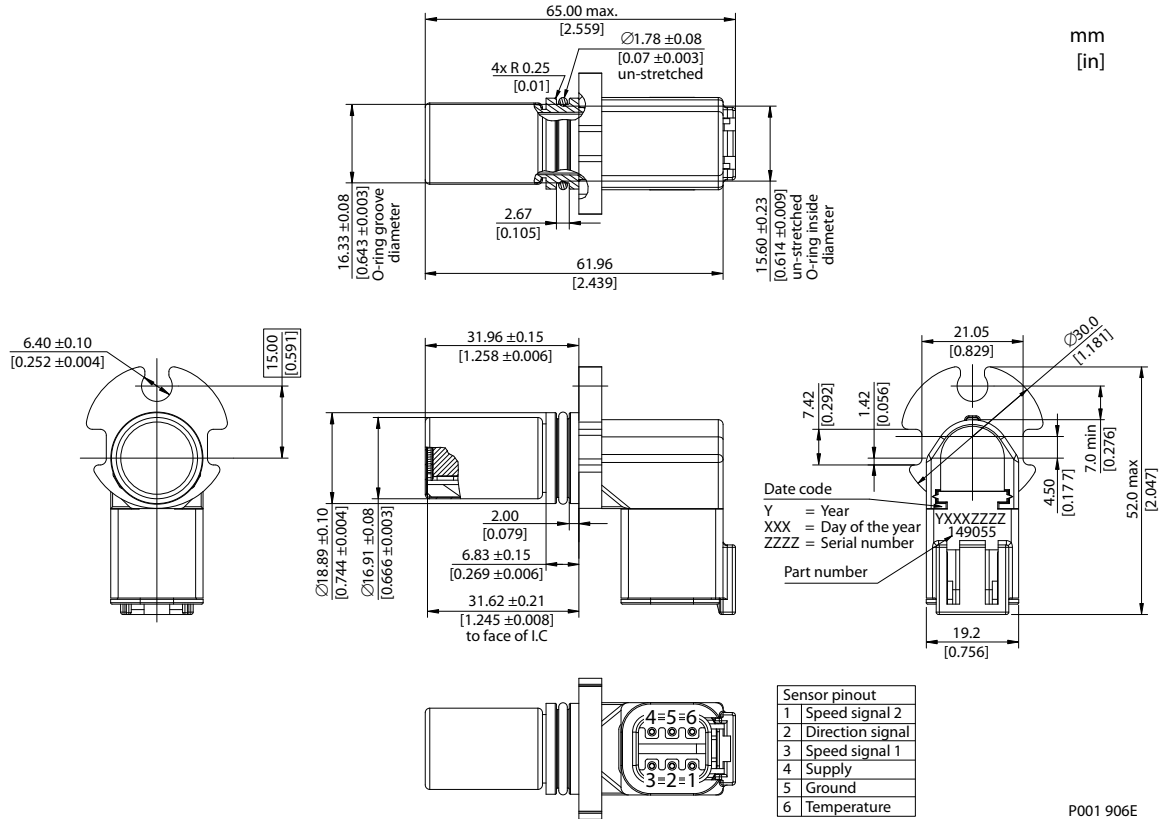

For more details about Mating connector, see the chapters #unique_10 and #unique_11

Sensor Installation

The sensor is positioned in the housing and fastened by one screw.

The gap between the sensor and the target does not need to be adjusted, nor it does need to be rotated for direction sensing.

Example:

H1B Motor housing
SAE & DIN

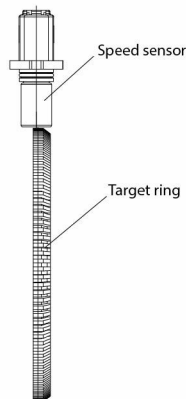

H1B Motor housing
Cartridge

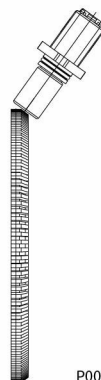

H1F Motor housing
SAE, DIN & Cartridge

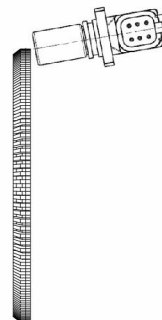

P003 523E

Speed sensor 4.5 – 8 V

Speed sensor connector, 6-pin

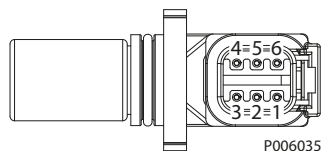

1. Speed signal 2
2. Direction signal
3. Speed signal 1
4. Supply
5. Ground
6. Temperature

Technical data

Parameter	Min.	Nom.	Max.	Note
Supply voltage	4.5 V _{DC}	5 V _{DC}	8 V _{DC}	Regulated supply voltage. Reverse polarity protected.
Supply protection	–	–	30 V _{DC}	Shuts off above 9 V.
Max. required supply current	–	–	25 mA	At supply voltage
Max. output current	–	–	50 mA	
Operation mode	NPN & PNP			Push-Pull amplifier
Temperature signal	-40°C = 2.318V	–	100°C = 0.675V	
Output low	5 %	8.5 %	12 %	Ratiometric output voltage Low state > 0 V to provide wire fault detection
Output high	88 %	91.5 %	95 %	
Detectable frequency range	1 Hz	–	10 000 Hz	
Ordering number	149055			
Color of connector	Black			

Duty Cycles

Output speed signal technical data and duty cycles graphs (clockwise and counterclockwise rotation).

Duty cycle clockwise rotation

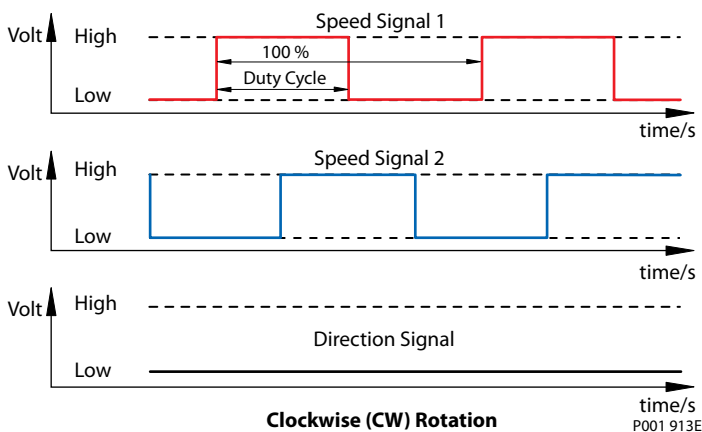

Speed sensor 4.5 – 8 V

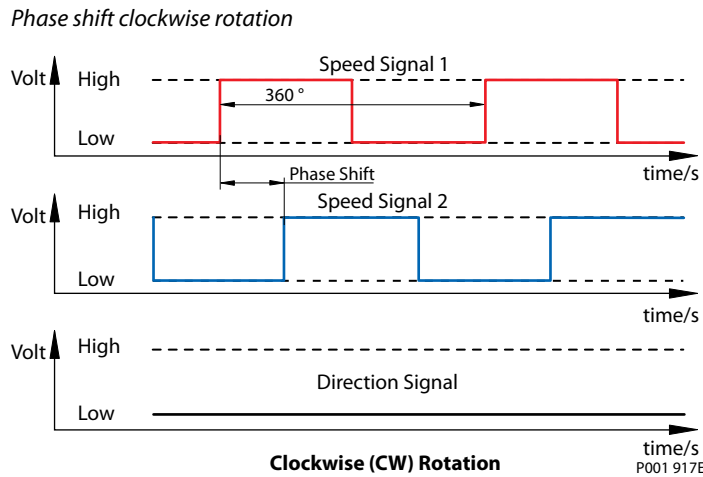
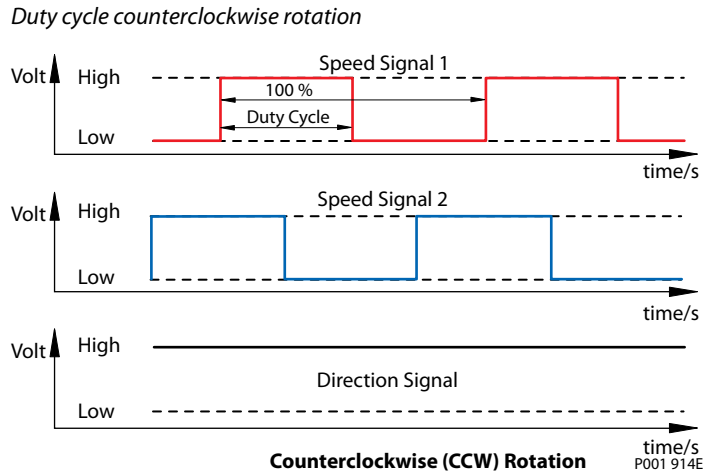

Wire Fault Detection

The output voltage levels are defined for a direct connection of the sensor to supply. The outputs are directly connected to a load which is 15k Ohm to ground and 15k Ohm to Supply.

The signal outputs are protected by an 1100 ohm (1k1) resistor. Speed signal 1 (pin 3) offers an advanced error detection by providing different signal levels in case of an error.

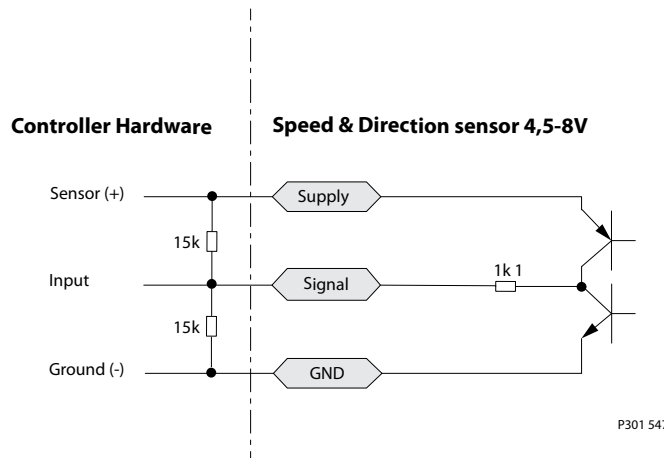

Speed sensor 4.5 – 8 V

Output Signals

Speed signals 1, 2 and direction signal

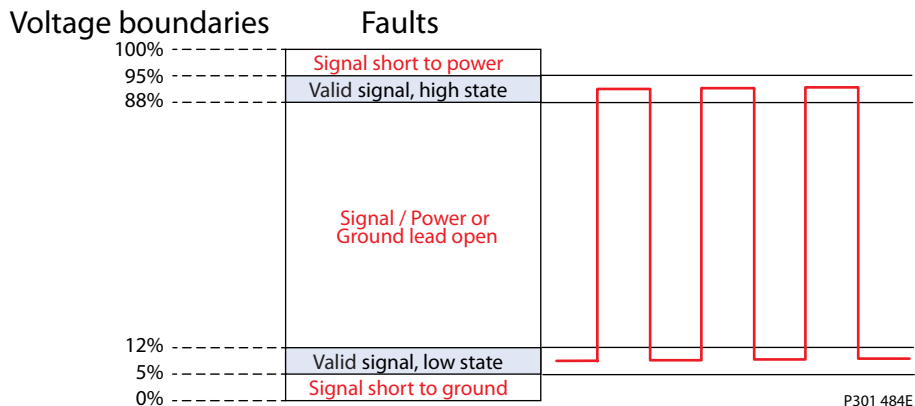

Temperature Signal

For calculation of the case fluid temperature and the output signal voltage, see the formulas below:

V_o – Measured output voltage (V)

$$V_o = (-3.88 \cdot 10^{-6} \cdot T^2) + (-1.15 \cdot 10^{-2} \cdot T) + 1.8639$$

T – Temperature (°C)

$$T = -1481.96 + \sqrt{2.1962 \cdot 10^6 + \frac{(1.8639 - V_o)}{3.88 \cdot 10^{-6}}}$$

Output signal voltage vs. Temperature

Temperature range							
-55 °C**	-40 °C	-30 °C	0 °C	+30 °C*	+80 °C	+100 °C	+130 °C**
2.485 V	2.318 V	2.205 V	1.864 V	1.515 V	0.919 V	0.675 V	0.303 V

* Accuracy: ±1.5 to ±4 °C

** Accuracy: ±2.5 to ±5 °C

Speed sensor 4.5 – 8 V

Response time in fluid

T₉₀ definition

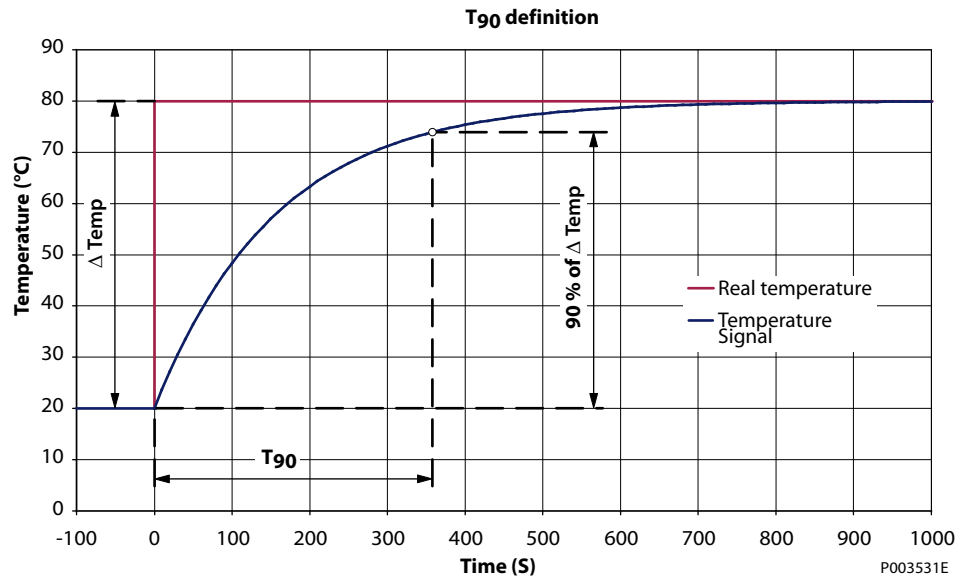

Response time in fluid (T₉₀) = 360 s

Speed Sensor 7 - 32 V

Speed Sensor 7 – 32 V_{DC} technical data and information about connector.

Speed sensor connector, 6-pin

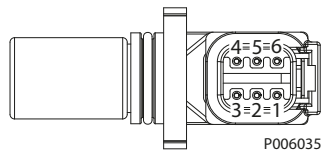

Pinout:

- 1. Speed signal 2
- 2. Direction signal
- 3. Speed signal 1
- 4. Supply
- 5. Ground
- 6. Temperature signal

Technical data

Parameter	Min.	Max.	Note
Supply voltage range	7 V _{DC}	32 V _{DC}	
Supply protection	–	36 V _{DC}	36 V _{DC} over voltage protection -36 V _{DC} permanent reverse polarity protection
Max. required supply current	–	30 mA	
Max. output current	–	50 mA	
Operation mode	NPN open collector		Internal 2k7 pull-up resistor to supply
Temperature signal	-40°C = 2.318V-		100°C = 0.675V
Output low signal range	2 %	8%	Max. output voltage 24 V _{DC}
Output high signal range	55 %	85 %	
Detectable frequency range	1 Hz	10 000 Hz	
Speed sensor order number	11232698		
Color of connector	Yellow		

Duty Cycles

Output speed signal technical data and duty cycles graphs (clockwise and counterclockwise rotation).

Duty cycle clockwise rotation

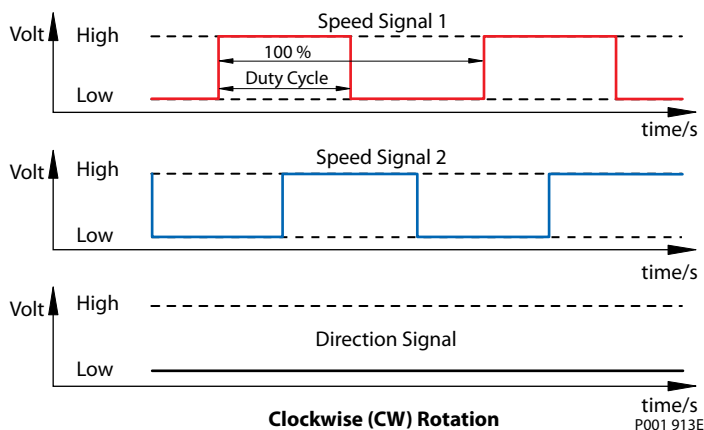

Speed Sensor 7 - 32 V

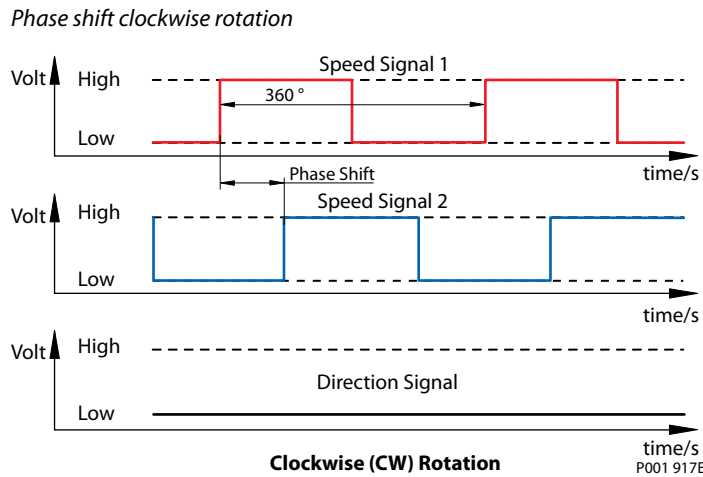
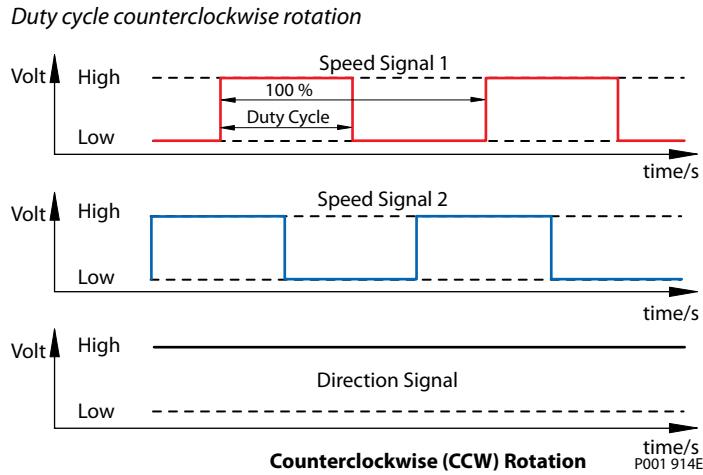

Wire Fault Detection

The output voltage levels are defined for a direct connection of the sensor to supply. The outputs are directly connected to a load which is 15k Ohm to ground and 15k Ohm to Supply.

The internal voltage regulator will limit the output signal to max. 24V in high state. The output is protected by 680 Ohm resistor. The pull-up resistor to supply is 2k7 Ohm.

This circuitry will generate voltage levels per condition as follows (typical outputs shown for reference only):

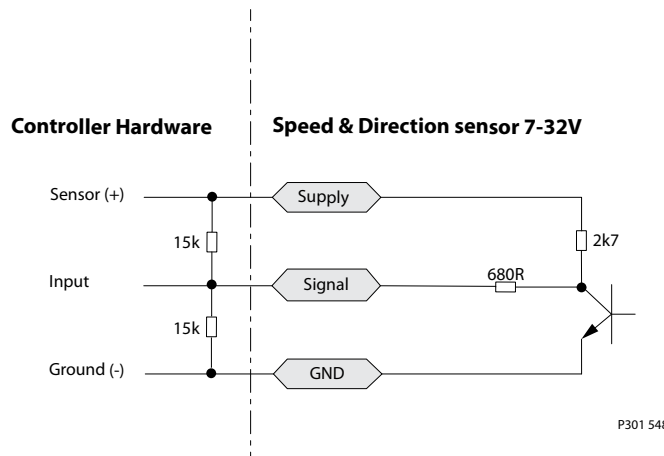

Speed Sensor 7 - 32 V

Output Signals

Speed Signals 1, 2 and direction signal

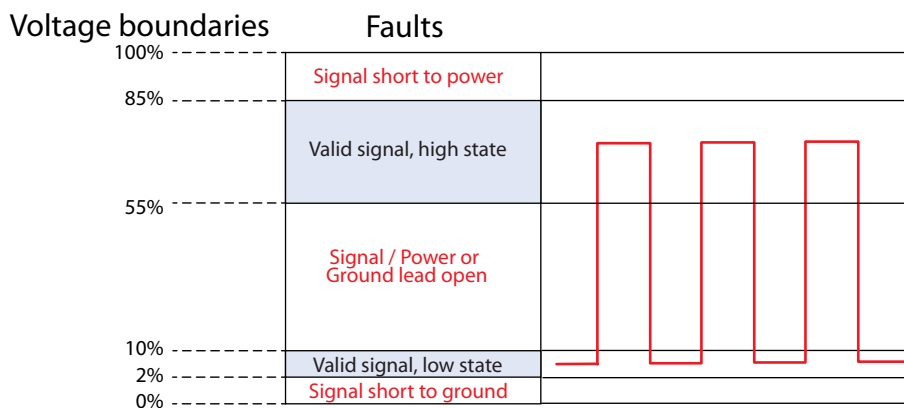

Temperature Signal

For calculation of the case fluid temperature and the output signal voltage, see the formulas below.

V_0 – Measured output voltage (V)

$$V_0 = (-3.88 \cdot 10^{-6} \cdot T^2) + (-1.15 \cdot 10^{-2} \cdot T) + 1.8639$$

T – Temperature (°C)

$$T = -1481.96 + \sqrt{2.1962 \cdot 10^6 + \frac{(1.8639 - V_0)}{3.88 \cdot 10^{-6}}}$$

Output signal voltage vs. Temperature

Temperature range							
-55 °C**	-40 °C	-30 °C	0 °C	+30 °C*	+80 °C	+100 °C	+130 °C**
2.485 V	2.318 V	2.205 V	1.864 V	1.515 V	0.919 V	0.675 V	0.303 V

* Accuracy: 30 ± 2.5 °C (max)

** Nonlinearity ± 0.4 °C

Speed Sensor 7 - 32 V

Response time in fluid

Temperature sensor response time

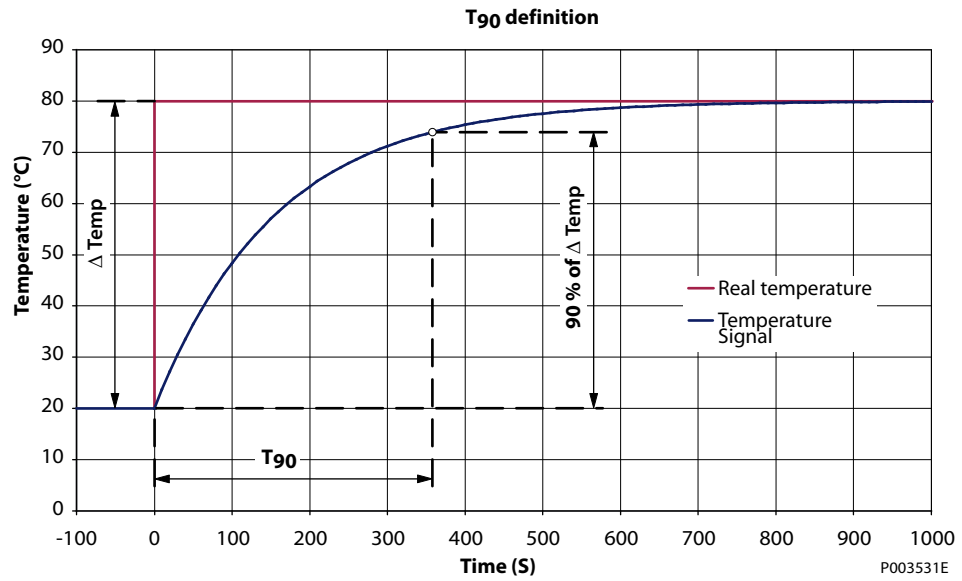

Response time in fluid (T₉₀) = 360 s

Appendix**MTTFd Values**

MTTFd values are calculated per ISO 13849, assuming 50 % of all failures are dangerous.

Duty cycle is 67% and main operating temperature assumption is 80 °C. According to the internal Danfoss standard 504H0078, the daily working time is calculated with 8 hours/day and 200 working days per year.

Sensor	Order Number	
	149055	11232698
Supply voltage	4,5-8V	7-32V
Speed Signals	two	two
MTTFd values	2098 years	301 years

Products we offer:

- Cylinders
- Electric converters, machines, and systems
- Electronic controls, HMI, and IoT
- Hoses and fittings
- Hydraulic power units and packaged systems
- Hydraulic valves
- Industrial clutches and brakes
- Motors
- PLUS+1® software
- Pumps
- Steering
- Transmissions

Danfoss Power Solutions designs and manufactures a complete range of engineered components and systems. From hydraulics and electrification to fluid conveyance, electronic controls, and software, our solutions are engineered with an uncompromising focus on quality, reliability, and safety.

Our innovative products makes increased productivity and reduced emissions a possibility, but it's our people who turn those possibilities into reality. Leveraging our unsurpassed application know-how, we partner with customers around the world to solve their greatest machine challenges. Our aspiration is to help our customers achieve their vision — and to earn our place as their preferred and trusted partner.

Go to www.danfoss.com or scan the QR code for further product information.

**Hydro-Gear**

www.hydro-gear.com

Daikin-Sauer-Danfoss

www.daikin-sauer-danfoss.com

**Danfoss
Power Solutions (US) Company**
2800 East 13th Street
Ames, IA 50010, USA
Phone: +1 515 239 6000

**Danfoss
Power Solutions GmbH & Co. OHG**
Krokamp 35
D-24539 Neumünster, Germany
Phone: +49 4321 871 0

**Danfoss
Power Solutions ApS**
Nordborgvej 81
DK-6430 Nordborg, Denmark
Phone: +45 7488 2222

**Danfoss
Power Solutions Trading
(Shanghai) Co., Ltd.**
Building #22, No. 1000 Jin Hai Rd
Jin Qiao, Pudong New District
Shanghai, China 201206
Phone: +86 21 2080 6201

Danfoss can accept no responsibility for possible errors in catalogues, brochures and other printed material. Danfoss reserves the right to alter its products without notice. This also applies to products already on order provided that such alterations can be made without subsequent changes being necessary in specifications already agreed. All trademarks in this material are property of the respective companies. Danfoss and the Danfoss logotype are trademarks of Danfoss A/S. All rights reserved.