

ENGINEERING  
TOMORROW



# Endless application possibilities Orbital Motors

**3 unique**

motor series options  
offer the right  
motor for each work  
function on your  
machine



# Count on efficient power delivery

Choose a Danfoss orbital motor, and experience the distinctive performance of a world technology leader.

## **Orbital motors that match your requirements**

For all your medium to heavy-duty tasks, we have the motor to match. Each of our motors provides a smooth, efficient and reliable performance. Comprising three series – the T-Series, O-Series and V-Series – and many additional options, our broad range is made to satisfy the requirements of your hydraulic system.

## **Higher productivity, lower emissions**

The best-in-class efficiency of our orbital motors reduces energy consumption and helps compensate for the lower power levels of emissions-compliant engines. Used in open or closed loop hydraulic systems, the motors minimize pressure drop and deliver a constant operating torque over the entire speed range of your application.

## **Support for optimized systems**

Our global service and technical support network is your professional partner – delivering experienced technical support for optimal solutions.

Our three motor series provide maximum flexibility, supporting the performance optimization of your entire hydraulic system.

## **Quality across the board**

Whether using orbital motors from our T-Series, O-Series or V-Series, you can expect the same high quality. Our global quality standards apply to all our international production sites, eliminating faults and ensuring reliable motor operation. Your vehicle benefits are high uptime, low maintenance and reduced total cost of ownership.



- **Reliable quality for medium- to heavy-duty tasks**
- **Best-in-class efficiency for reduced heat load and lower fuel costs**
- **Compact design with optional extras for high system performance**
- **Robust drivetrain for longer service life and improved productivity**



# The broadest range – the safest bet

The Danfoss orbital motor range is the broadest on the market – and your safest bet for quality, durability, efficiency and reliability.

In the face of today's environmental legislation and increasing international price competition, mobile vehicles are ever more dependent on hydraulic solutions optimized for their duty cycle.

Our orbital motors keep emissions and energy consumption down, productivity up and overall cost-of-ownership to a competitive minimum.

To help you identify the right motor for a specific task, we have divided our range into three series.

## Our three series tailored for medium- to heavy-duty tasks

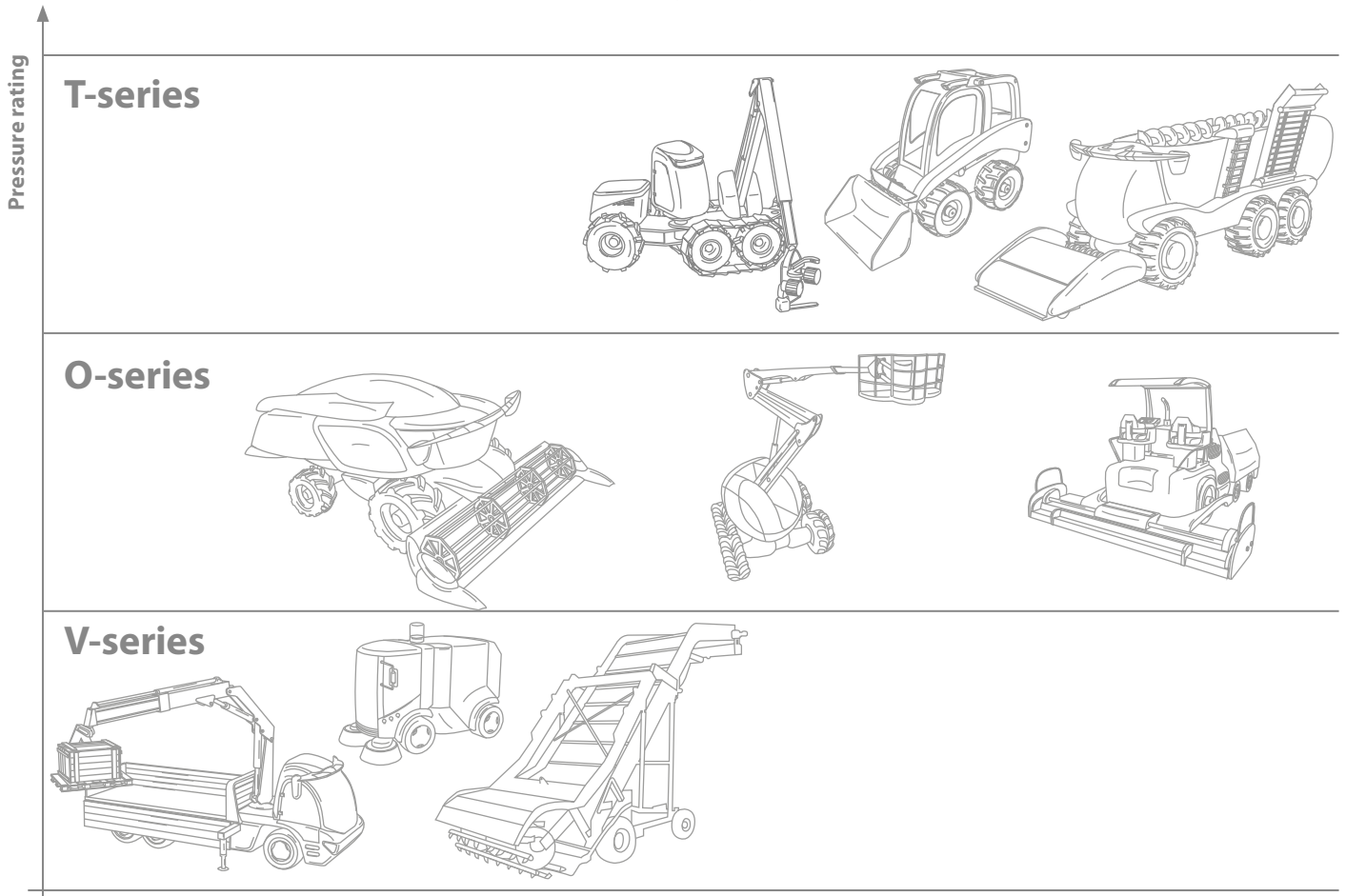



#### **T-series – the highest torque**

Leading performance with a long lifespan makes light work of the heaviest duties. Offering a intermittent pressure up to 350 bar [5075 psi] and a high starting torque, the T-Series is your energy-efficient choice for the toughest working environments. Ideal for road rollers, beet harvesters and forestry machines.



#### **O-series – the flexible choice**

The O-Series is flexible beyond compare. Delivering premium power across the board, these motors cover small to large, heavy-duty needs with intermittent pressures up to 275 bar [3990 psi]. Robust, reliable and designed to fulfill the latest emissions standards, the O-Series offers you the motors of choice for turf care and agricultural equipment, forklifts and industrial sweepers.



#### **V-series – the core solution**

The V-Series is your quality benchmark for the medium duty range. Based on proven technology, these reliable motors will reduce your overall system costs while adding value to your machine. Suitable applications include seasonal machines, such as harvesters, and medium-duty tasks, such as driving agricultural conveyors and sweeper brushes.



# Optional extras for your system

## Examples from our portfolio

- Wheel motors with recessed mounting flange for optimal utilization of bearing capacity
- Motors optimized for enhanced low-speed performance
- Short and ultra short motors for optimal system integration
- Special dust seal ring for additional shaft seal protection
- Motors with integrated flushing valve for continuous renewal and cooling of oil in a closed circuit
- Corrosion-resistant parts for applications used in harsh environments
- Motor with tacho connection for speed monitoring
- EMD speed sensor for speed monitoring and regulation

## PLUS+1® Compliant EMD speed sensor

Our EMD speed sensor is designed for precision machine performance. Equipped with a magnetic sensing mechanism, it has the exclusive capability to measure both speed and direction, giving optimal motor control even at low revolution.

Free of contact with the hydraulic oil, the speed sensor is robust and easily exchangeable in the field. Flexible configuration with CAN bus and pulse output modes reduces system installation costs overall.

Choose the versatile EMD speed sensor for many of your application needs.

Full compliance with our PLUS+1 electronic control platform delivers key performance benefits:

- Configurable sensor setup enables customized motor control
- Easy and efficient system integration
- Single software platform for electrohydraulic system configuration
- Faster time to market

**Our orbital motors come with a multitude of features and additional options that bring maximum flexibility to your hydraulic system designs.**



Endless application possibilities

8 cm<sup>3</sup> [0.49 in<sup>3</sup>]

Salt & grit spreaders

Forklift trucks – 3 wheel

Mini excavator

Sweepers (street & industrial)

Consumer mowers

Commercial vehicles

Combine harvester

Municipal vehicles (<1,5t)

Bale wrapper

Aerial lifts (boom)

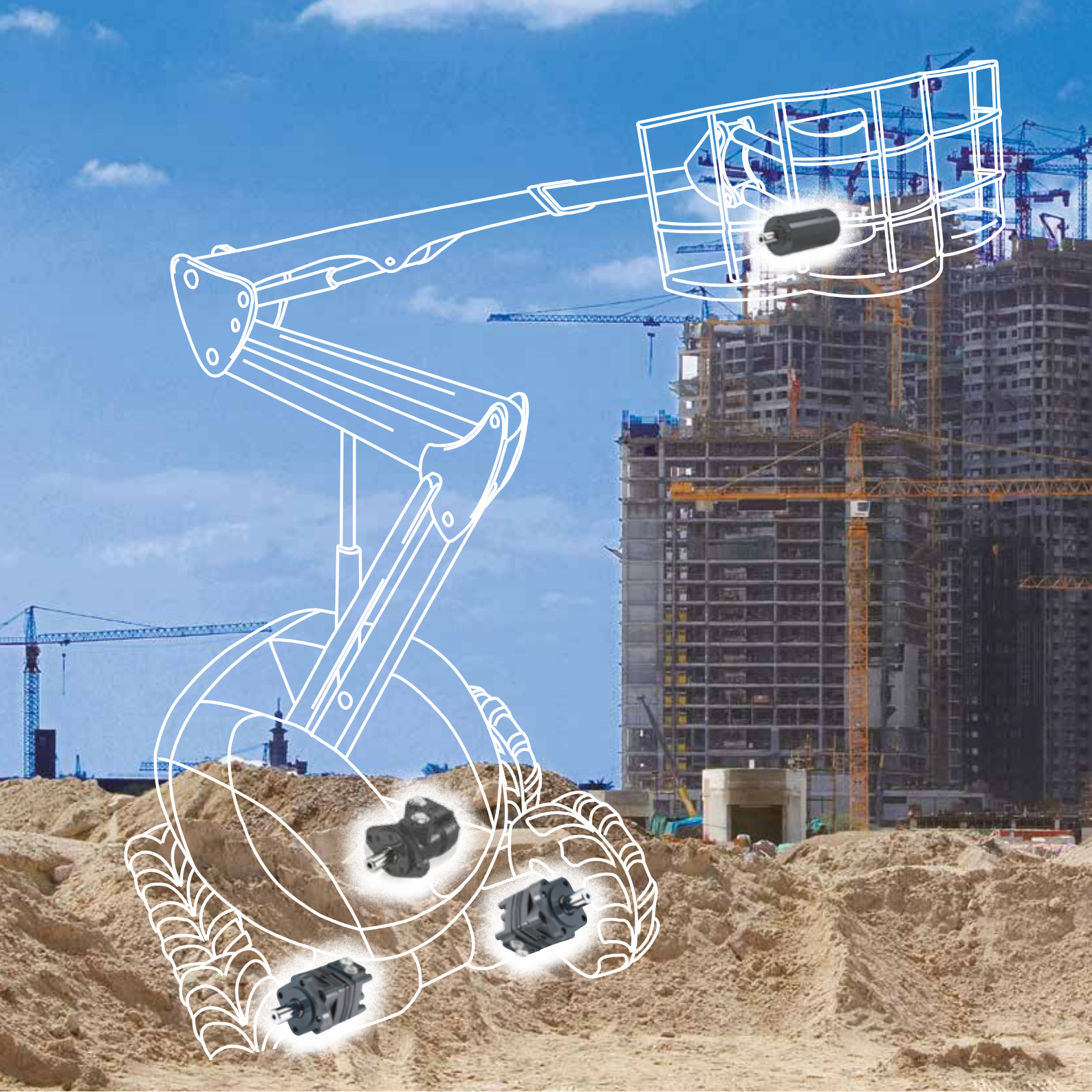

800 cm<sup>3</sup> [48.8 in<sup>3</sup>]

tractors (< 2t)	Skid steer loader	Forestry harvester head
lawn mowers & golf equipment	Screening & crushing machines	
	Construction attachments	
Municipal vehicles (>1,5t)	Road rollers (<2t)	Trench compactor
	Asphalt pavers	
excavators & scissor)		Harvester (beet & potato)



## About Danfoss Power Solutions

**Danfoss Power Solutions** is a global manufacturer and supplier of high-quality hydraulic and electronic components. We specialize in providing state-of-the-art technology and solutions that excel in the harsh operating conditions of the mobile off-highway market. Building on our extensive applications expertise, we work closely with you to ensure exceptional performance for a broad range of off-highway vehicles. We help OEMs around the world speed up system development, reduce costs and bring vehicles to market faster.

Danfoss Power Solutions – your strongest partner in mobile hydraulics.

### Products we offer:

- Bent Axis Motors
- Closed Circuit Axial Piston Pumps and Motors
- Displays
- Electrohydraulic Power Steering
- Electrohydraulics
- Hydraulic Power Steering
- Integrated Systems
- Joysticks and Control Handles
- Microcontrollers and Software
- Open Circuit Axial Piston Pumps
- Orbital Motors
- PLUS+1® GUIDE
- Proportional Valves
- Sensors
- Steering
- Transit Mixer Drives

Wherever off-highway vehicles are at work, so is Danfoss Power Solutions. We offer you expert worldwide support for ensuring the best possible solutions for outstanding performance. And with an extensive network of Global Service Partners, we also provide you with comprehensive global service for all of our components.

Go to [www.powersolutions.danfoss.com](http://www.powersolutions.danfoss.com) for further product information.

### Danfoss Power Solutions (US) Company

2800 East 13th Street  
Ames, IA 50010, USA  
Phone: +1 515 239 6000

### Danfoss Power Solutions ApS

Nordborgvej 81  
DK-6430 Nordborg, Denmark  
Phone: +45 7488 2222

### Danfoss Power Solutions GmbH & Co. OHG

Krokamp 35  
D-24539 Neumünster, Germany  
Phone: +49 4321 871 0

### Danfoss Power Solutions Trading (Shanghai) Co. Ltd.

Building #22, No. 1000 Jin Hai Rd  
Jin Qiao, Pudong New District  
Shanghai, China 201206  
Phone: +86 21 3418 5200