

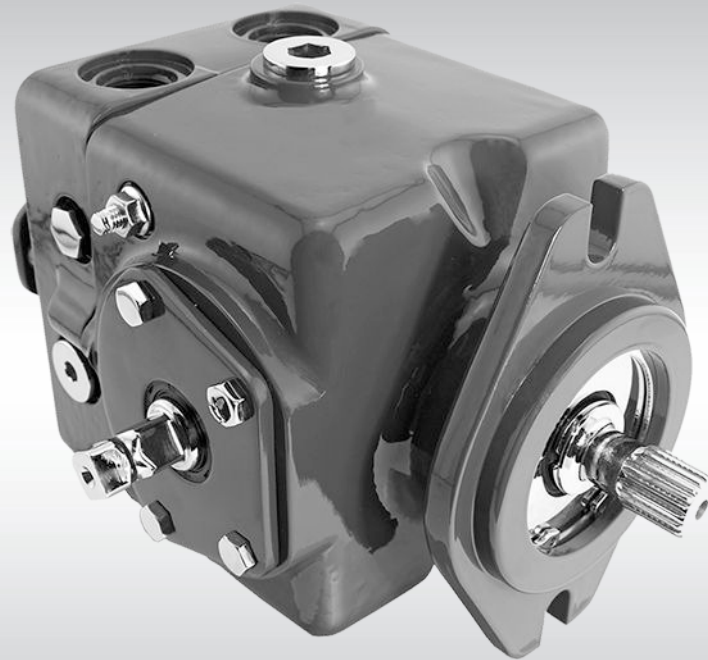

Service Manual  
Closed Circuit Axial Piston Pumps  
**LPV**



**Revision history***Table of revisions*

<b>Date</b>	<b>Changed</b>	<b>Rev</b>
July 2015	Danfoss layout	0100
November 2006	First printing	A

**Contents**
**Introduction**

Overview.....	4
Warranty.....	4
General instructions.....	4
Safety Precautions.....	5
Symbols used in Danfoss literature.....	6
Design.....	6
Direct displacement drive system.....	8
LPV Pump schematic diagram.....	8

**Operation**

HPRV (High pressure relief valve).....	9
Bypass function.....	9
CPRV (Charge pressure relief valve).....	10
Loop flushing valve.....	10
Neutral return mechanism.....	11

**Technical specifications**

Specifications.....	12
---------------------	----

**Fluid and filter recommendations**

Fluid and filter recommendations.....	15
---------------------------------------	----

**Startup procedures**

General .....	16
Start-up procedure.....	16

**Pressure measurements**

Required tools.....	17
Port locations and gauge installation.....	17

**Troubleshooting**

Overview.....	18
System operating hot.....	18
Transmission operates normally in one direction only.....	18
System will not operate in either direction.....	18
System noise or vibration.....	19
Sluggish system response.....	19

**Adjustments**

Pump adjustment.....	20
Standard procedures, inspections, and adjustments.....	20
Charge pressure relief valve adjustments.....	20
System check and HPRV.....	22
Checking for proper HPRV valve operation.....	22
Loop flushing valve.....	22
Neutral return mechanism.....	23
Leveling swashplate with pump installed on machine.....	24

**Minor repair**

Input shaft and seal.....	25
Trunion seal.....	29
High Pressure Relief Valves.....	30
Charge pressure relief valve.....	31
Loop flushing valve.....	32
Bypass valve.....	33
Coupling.....	34

**Torque chart**

Fasteners and plugs.....	35
Fastener size and torque chart.....	35
Plug size and torque chart.....	35

## Introduction

### Overview

This manual includes information for the installation, maintenance, and minor repair of the LPV pump. It includes a description of the unit and its individual components, troubleshooting information, and minor repair procedures.

Performing minor repairs requires the unit to be removed from the vehicle/machine. Thoroughly clean the unit before beginning maintenance, or repair activities. Since dirt and contamination are the greatest enemies of any type of hydraulic equipment, follow cleanliness requirements strictly. This is especially important when changing the system filter and when removing hoses or plumbing.

A worldwide network of Danfoss Global Service Partners is available for major repairs. Danfoss Global Service Partners are trained by the factory and certified on a regular basis. You can locate your nearest Global Service Partner using the distributor locator at [www.sauer-danfoss.com](http://www.sauer-danfoss.com). Click on the *Sales and Service* link.

### Warranty

Performing installation, maintenance, and minor repairs according to the procedures in this manual will not affect your warranty. Major repairs requiring the removal of a unit's rear cover or front flange voids the warranty unless done by a Danfoss Global Service Partner.

### General instructions

Follow these general procedures when repairing Series LPV variable displacement closed circuit pumps.

#### Remove the unit



Prior to performing major repairs, remove the unit from the vehicle/machine. Chock the wheels on the vehicle or lock the mechanism to inhibit movement. Be aware that hydraulic fluid may be under high pressure and / or hot. Inspect the outside of the pump and fittings for damage. Cap hoses after removal to prevent contamination.

#### Keep it clean



Cleanliness is a primary means of assuring satisfactory pump life, on either new or repaired units. Clean the outside of the pump thoroughly before disassembly. Take care to avoid contamination of the system ports. Cleaning parts by using a clean solvent wash and air drying is usually adequate.

As with any precision equipment, all parts must be kept free of foreign materials and chemicals. Protect all exposed sealing surfaces and open cavities from damage and foreign material. If left unattended, cover the pump with a protective layer of plastic.

#### Lubricate moving parts



During assembly, coat all moving parts with a film of clean hydraulic oil. This assures that these parts will be lubricated during start-up.

#### Replace all O-rings and gaskets



## Introduction

It is recommended that all O-rings be replaced. Lightly lubricate all O-rings with clean petroleum jelly prior to assembly.

### Secure the unit



For major repair, place the unit in a stable position with the shaft pointing downward. It will be necessary to secure the pump while removing and torquing the endcap bolts.

## Safety Precautions

Always consider safety precautions before beginning a service procedure. Protect yourself and others from injury. Take the following general precautions whenever servicing a hydraulic system.

### Unintended Machine Movement

#### **Warning**

---

Unintended movement of the machine or mechanism may cause injury to the technician or bystanders. To protect against unintended movement, secure the machine or disable/disconnect the mechanism while servicing.

---

### Flammable Cleaning Solvents

#### **Warning**

---

Some cleaning solvents are flammable. To avoid possible fire, do not use cleaning solvents in an area where a source of ignition may be present.

---

### Fluid Under Pressure

#### **Warning**

---

Escaping hydraulic fluid under pressure can have sufficient force to penetrate your skin causing serious injury and/or infection. This fluid may also be hot enough to cause burns. Use caution when dealing with hydraulic fluid under pressure. Relieve pressure in the system before removing hoses, fittings, gauges, or components. Never use your hand or any other body part to check for leaks in a pressurized line. Seek medical attention immediately if you are cut by hydraulic fluid.

---

### Personal Safety

#### **Warning**

---

Protect yourself from injury. Use proper safety equipment, including safety glasses, at all times.

---

### Hazardous Material

#### **Warning**





























---

Hydraulic fluid contains hazardous material. Avoid prolonged contact with hydraulic fluid. Always dispose of used hydraulic fluid according to state, and federal environmental regulations.

---

## Introduction

### Symbols used in Danfoss literature

 WARNING may result in injury	 Tip, helpful suggestion
 CAUTION may result in damage to product or property	 Lubricate with hydraulic fluid
 Reusable part	 Apply grease / petroleum jelly
 Non-reusable part, use a new part	 Apply locking compound
 Non-removable item	 Inspect for wear or damage
 Option - either part may exist	 Clean area or part
 Superseded - parts are not interchangeable	 Be careful not to scratch or damage
 Measurement required	 Note correct orientation
 Flatness specification	 Mark orientation for reinstallation
 Parallelism specification	 Torque specification
 External hex head	 Press in - press fit
 Internal hex head	 Pull out with tool – press fit
 Torx head	 Cover splines with installation sleeve
 O-ring boss port	 Pressure measurement/gauge location or specification

The symbols above appear in the illustrations and text of this manual. They are intended to communicate helpful information at the point where it is most useful to the reader. In most instances, the appearance of the symbol itself denotes its meaning. The legend above defines each symbol and explains its purpose.

## Design

LPV represents a family of hydrostatic pumps for low to medium power applications with maximum pressures up to 345 bar [5000 psi]. These pumps can be applied with other products in a system to transfer and control hydraulic power.

LPV pumps provide an infinitely variable speed range between zero and maximum in both forward and reverse modes of operation. LPV pumps come in three displacements (25 cm<sup>3</sup> [1.53 in<sup>3</sup>], 30 cm<sup>3</sup> [1.83 in<sup>3</sup>], and 35 cm<sup>3</sup> [2.32 in<sup>3</sup>]).

LPV pumps are compact, high power density units. All models use the parallel axial piston / slipper concept in conjunction with a tiltable swashplate to vary the pump's displacement. Reversing the angle of the swashplate reverses the flow of fluid from the pump, reversing the direction of rotation of the motor output.

LPV pumps are provided with an internal neutral return mechanism for ease of installation, and are available with optional loop flushing for circuit flexibility. LPV pumps are designed to receive charge flow from an auxiliary circuit or from a gear pump mounted on the auxiliary mounting pad. LPV pumps feature an SAE A auxiliary mounting pad to accept auxiliary hydraulic pumps for use in complementary hydraulic systems.

LPV pumps include a trunnion style direct displacement control.

Introduction

LPV cross section

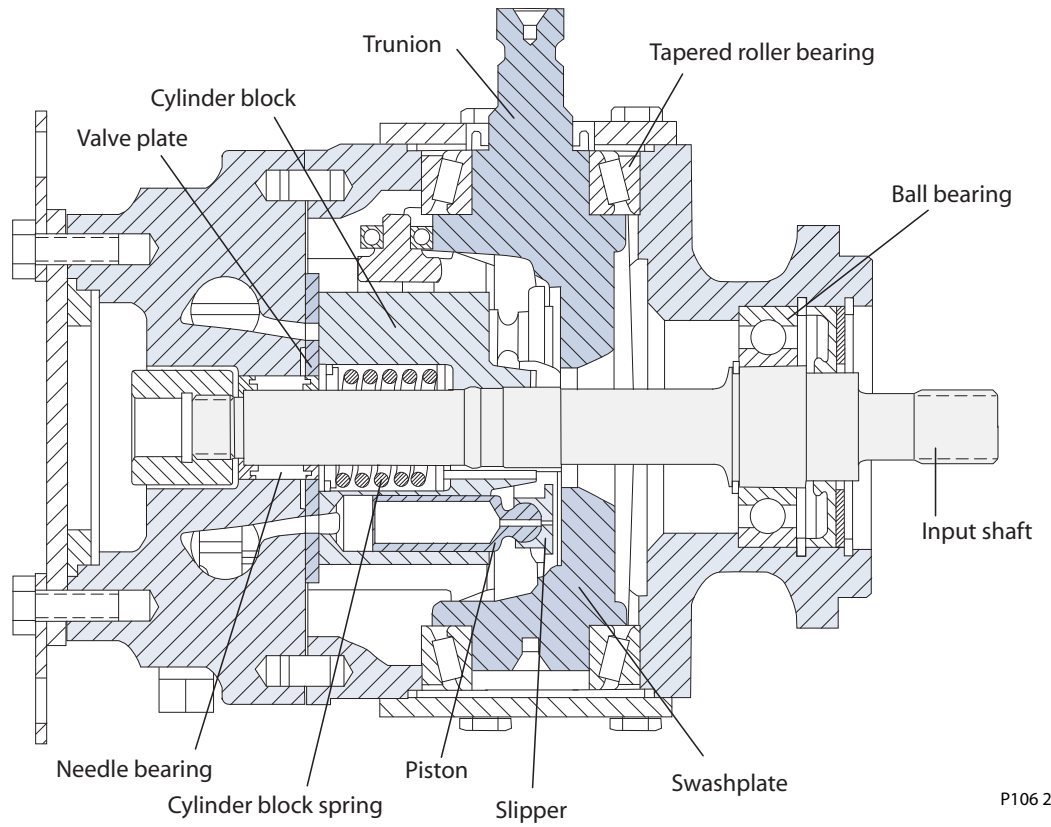

Introduction

Direct displacement drive system

The direct displacement control varies the swashplate angle. Swashplate angle determines pump flow and motor speed.

Pictorial circuit diagram

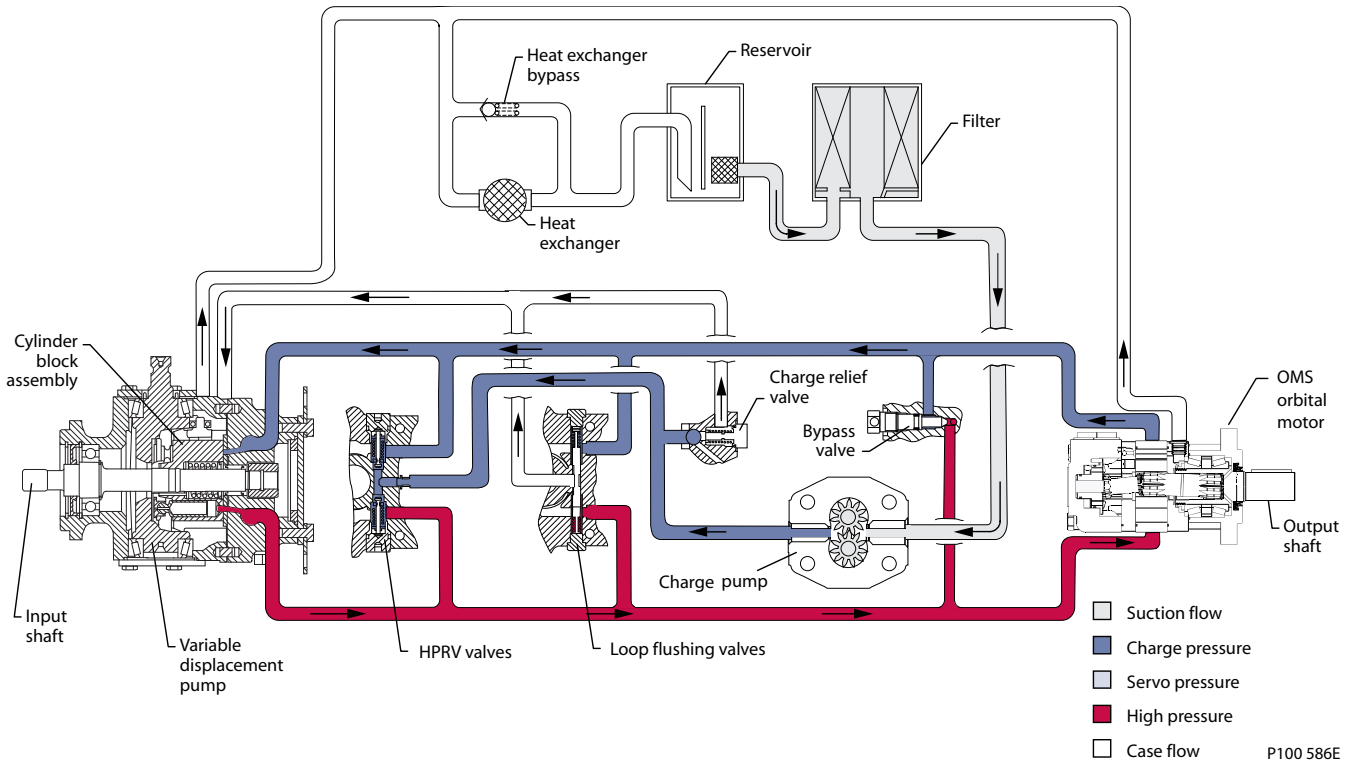

The diagram shows an LPV pump driving an OMR motor. The system shown uses an external charge pump and external filter. Charge pressure relief valves, high pressure relief valves, and loop flushing valves are shown separated from the pump to provide clarity to the hydraulic system.

LPV Pump schematic diagram

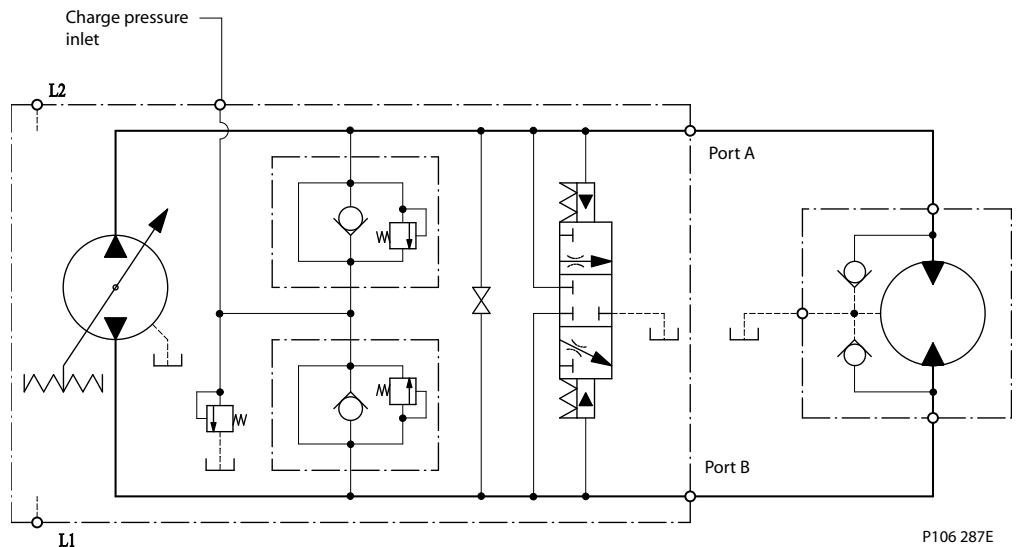



Operation

**HPRV (High pressure relief valve)**

LPV pumps are equipped with a combination high pressure relief and charge check valve. The high-pressure relief function is a dissipative (with heat generation) pressure control valve for the purpose of limiting excessive system pressures. The charge check function acts to replenish the low-pressure side of the working loop with charge oil. Each side of the transmission loop has a dedicated HPRV valve that is non-adjustable with a factory set pressure. When system pressure exceeds the factory setting of the valve, oil is passed from the high pressure system loop, into the charge gallery, and into the low pressure system loop via the charge check.

*HPRV valve*

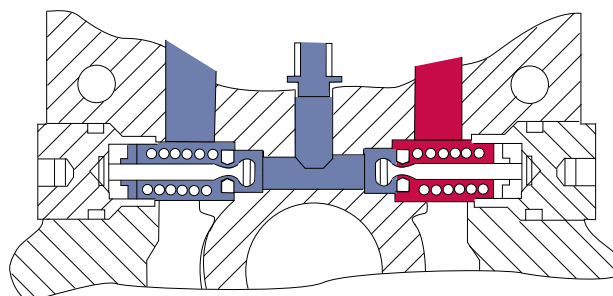

P106 273E

**Bypass function**

The LPV contains a dedicated bypass valve. The bypass function is activated when the bypass valve is mechanically backed out 3 full turns (maximum). The bypass function allows a machine or load to be moved without rotating the pump shaft or prime mover.

*Bypass valve*

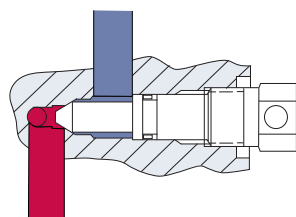

P106 286E

**⚠ Caution**

Excessive speeds and extended load/vehicle movement must be avoided. The load or vehicle should be moved not more than 20% of maximum speed and for a duration not exceeding 3 minutes. Damage to drive motor(s) is possible. When the bypass function is no longer needed care should be taken to reseat the bypass valves to the normal operating position.

Operation

**CPRV (Charge pressure relief valve)**

An internal charge relief valve regulates charge pressure. Charge pressure is supplied to maintain a minimum pressure in the low side of the transmission loop.

*CPRV valve*

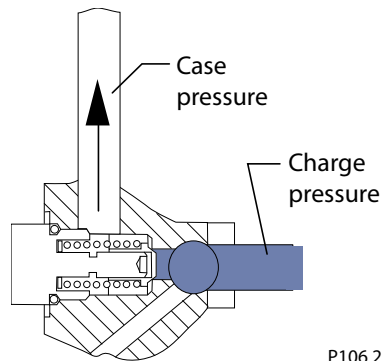

P106 274E

Minimum charge pressure is the lowest pressure allowed to maintain a safe working condition in the low side of the loop.

Maximum charge pressure is the highest charge pressure allowed by the charge relief adjustment, and which provides normal component life. The charge pressure setting listed in the order code is the set pressure of the charge relief valve with the pump in neutral, operating with 5 gpm of charge flow. The charge pressure setting is referenced to case pressure. Charge pressure is the differential pressure above case pressure.

**Loop flushing valve**

LPV pumps incorporate an optional integral loop flushing valve, which removes heat and contaminants from the main loop at an increased rate.

*Loop flushing valve*

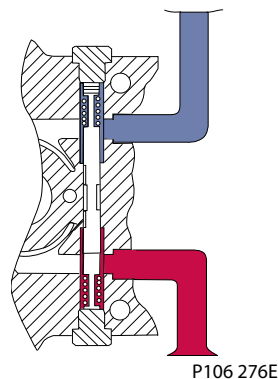

P106 276E

Operation

Neutral return mechanism

The neutral return mechanism is designed to mechanically return the pump to zero displacement. A cam allows precise zero displacement adjustment.

*Neutral return adjusting cam*

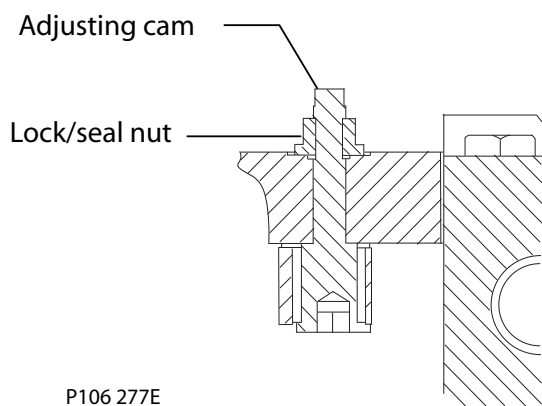

*Neutral return mechanism*

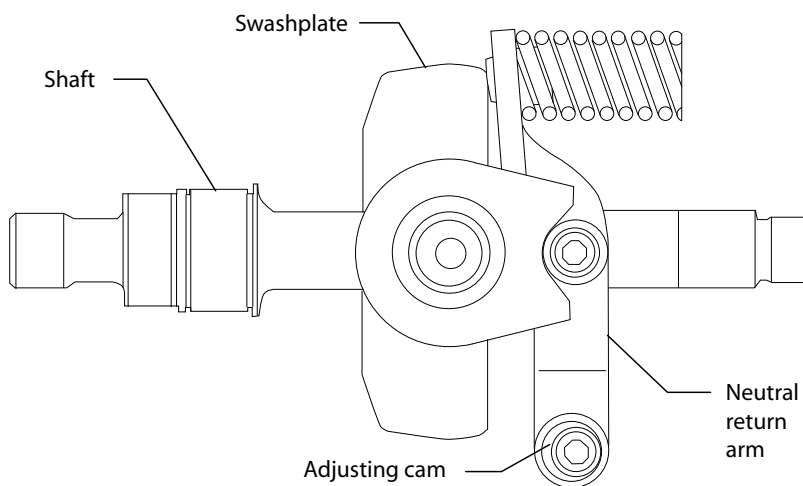

**Technical specifications**
**Specifications**
*General specifications*

Design	Axial piston pump of trunion swashplate design with variable displacement
Direction of rotation	Clockwise, counterclockwise
pipe connections	Main pressure ports: SAE straight thread O-ring boss
Recommended installation position	Pump installation recommended with control position on the top or side. Consult Danfoss for non conformance to these guidelines. The housing must always be filled with hydraulic fluid.

*Physical properties*

		<b>Displacement</b>		
<b>Feature</b>	<b>Unit</b>	<b>25</b>	<b>30</b>	<b>35</b>
Maximum Displacement	cm <sup>3</sup> [in <sup>3</sup> ]	25 [1.53]	30 [1.83]	35 [2.14]
Flow at rated speed (theoretical)	l/min [US gal/min]	85.2 [22.5]	104.9 [27.7]	137.0 [36.2]
Input torque at maximum displacement (theoretical)	N·m/ bar [lbf·in/1000 psi]	0.4 [244]	0.5 [291]	0.6 [340]
Mass moment of inertia of internal rotating components	kg·m <sup>2</sup> [slug·ft <sup>2</sup> ]	0.001670 [0.0012]	0.001580 [0.00120]	0.001530 [0.00113]
Weight	kg [lb]	23 [51]		
Rotation	Clockwise, Counterclockwise			
Mounting	SAE B 2 bolt			
Auxiliary mounting	SAE J744 A 9T, SPCL 11T			
System ports (type)	1 1/16-12 UNF-2B ORB			
System ports (location)	Twin radial			
Control types	Direct displacement control			
Shafts	Splined	Splined SAE13 tooth, 15 tooth		
Case drain ports	1 1/16-12 SAE ORB			

*Operating parameters*

			<b>Displacement</b>		
Rating		Units	25	30	35
Input speed	minimum	min <sup>-1</sup> (rpm)	500	500	500
	continuous		3400	3500	3600
	maximum		3950	4150	4300
Working pressure	continuous	bar [psi]	210 [3045]	175 [2540]	140 [2030]
	maximum		345 [5000]		
External shaft loads	External moment (Me)	N·m [lbf·in]	7.7 [68]		
	Thrust in (Tin), out (Tout)	N [lbf]	750 [169]		
Bearing life (max. swashplate angle and max. continuous speed)	at 210 bar [3045 psi]	B10 hours	120,000	63,000	37,000
Charge pressure	minimum	bar [psi]	6 [87]		
	maximum		20 [300]		

**Technical specifications**
*Operating parameters (continued)*

Case pressure	rated	bar [psi]	2 [29]
	maximum		6 [87]

*Sound levels<sup>1</sup>*

dB(A)	100 bar [1450 psi]	200 bar [2900 psi]	300 bar [3451 psi]
Displ. cm <sup>3</sup> [in <sup>3</sup> ]	1000 min <sup>-1</sup> (rpm)	1000 min <sup>-1</sup> (rpm)	1000 min <sup>-1</sup> (rpm)
25 [1.53]	62	66	68
35 [2.14]	61	66	69

*Sound levels*

dB(A)	100 bar [1450 psi]	200 bar [2900 psi]	300 bar [3451 psi]
Displ. cm <sup>3</sup> [in <sup>3</sup> ]	3000 min <sup>-1</sup> (rpm)	3000 min <sup>-1</sup> (rpm)	3000 min <sup>-1</sup> (rpm)
25 [1.53]	70	74	76
35 [2.14]	71	75	80

<sup>1</sup> Sound data was collected in a semi-anechoic chamber. Values have been adjusted (-3 dB) to reflect anechoic levels.

*Fluid specifications*

Feature		Unit	Displacement cm <sup>3</sup> [in <sup>3</sup> ] 25 [1.53], 30 [1.83], 35 [2.14]
Viscosity	Minimum	mm <sup>2</sup> /s [SUS]	7 [47]
	Recommended range		12-60 [66-278]
	Maximum		1600 [7500]
Temperature Range <sup>2</sup>	Minimum	C° [F°]	-40 [-40]
	Rated		82 [180]
	Maximum intermittent		100 [212]
Filtration	Cleanliness per ISO 4406		22/18/13
	Efficiency (charge pressure filtration)	β-ratio	β <sub>15-20</sub> = 75 (β <sub>10</sub> ≥ 10)
	Efficiency (suction filtration)		β <sub>35-45</sub> = 75 (β <sub>10</sub> ≥ 2)
	Recommended inlet screen mesh size	μ m	100 - 125

<sup>2</sup>At the hottest point, normally case drain port.

*Mounting flange allowable overhung parameters*

Continuous load moment (M <sub>c</sub> )		Shock load moment (M <sub>s</sub> )	
N·m	[lbf·in]	N·m	[lbf·in]
361	[3200]	617	[5470]

**Technical specifications**

*Mounting flange G-factors for sample applications*

<b>Application</b>	<b>Continuous (vibratory) acceleration (G<sub>c</sub>)</b>	<b>Maximum (shock) acceleration (G<sub>s</sub>)</b>
Skid steer loader	6	10
Trencher (rubber tires)	6	8
Asphalt paver	6	6
Windrower	6	5
Aerial lift	6	4
Turf care vehicle	6	4
Vibratory roller	6	10

Applications experiencing extreme resonant vibrations may require additional pump support. Refer to [LPV Technical Information 520L0954](#) for information concerning mounting flange loads.

---

Fluid and filter recommendations

**Fluid and filter recommendations**

To ensure optimum life, perform regular maintenance of the fluid and filter. Contaminated fluid is the main cause of unit failure. Take care to maintain fluid cleanliness when servicing.

Check the reservoir daily for proper fluid level, the presence of water, and rancid fluid odor. Fluid contaminated by water may appear cloudy or milky or free water may settle in the bottom of the reservoir. Rancid odor indicates the fluid has been exposed to excessive heat. Change the fluid immediately if these conditions occur. Correct the problem immediately.

Inspect vehicle for leaks daily.

*Fluid and filter change interval*

Reservoir type	Max oil change interval
Sealed	2000 hours
Breather	500 hours

Change the fluid and filter per the vehicle/machine manufacturer's recommendations or at these intervals:

First fluid change recommended at 500 hours.

 **Caution**

High temperatures and pressures will result in accelerated fluid aging. More frequent fluid changes may be required.

Change the fluid more frequently if it becomes contaminated with foreign matter (dirt, water, grease, etc.) or if the fluid is subjected to temperature levels greater than the recommended maximum.

Dispose of used hydraulic fluid properly. Never reuse hydraulic fluid.

Change filters whenever the fluid is changed or when the filter indicator shows that it is necessary to change the filter. Replace all fluid lost during filter change.

 **Warning**

**Hazardous material**

Hydraulic fluid contains hazardous material. Avoid contact with hydraulic fluid. Always dispose of used hydraulic fluid according to state, and federal environmental regulations.

**Hazardous material**

 **Warning**

**W Warning**

Hydraulic fluid contains hazardous material. Avoid contact with hydraulic fluid. Always dispose of used hydraulic fluid according to state, and federal environmental regulations.

## Startup procedures

### General

Follow this procedure when starting-up a new pump installation or when restarting an installation in which the pump has been removed and re-installed on a machine. Ensure pump has been thoroughly tested on a test stand before installing on a machine.

**⚠ Warning**

Unintended movement of the machine or mechanism may cause injury to the technician or bystanders. To protect against unintended movement, secure the machine or disable/disconnect the mechanism while servicing.

Prior to installing the pump, inspect for damage that may have occurred during shipping.

### Start-up procedure

1. Ensure that the machine hydraulic oil and system components (reservoir, hoses, valves, fittings, and heat exchanger) are clean and free of any foreign material.
2. Install new system filter element(s) if necessary. Check that inlet line fittings are properly tightened and there are no air leaks.
3. Install the pump. Install a 50 bar [1000 psi] gauge in the charge pressure gauge port M3.
4. Fill the housing by adding filtered oil in the upper case drain port.
5. Fill the reservoir with hydraulic fluid of the recommended type and viscosity. Use a 10-micron reservoir filler filter. Ensure inlet line from reservoir to pump is filled.
6. Disconnect the pump from control.

After start-up the oil level in the reservoir may drop due to filling of the system components. Check the level in the reservoir to maintain a full oil level throughout the start-up.

**⚠ Warning**

Damage to hydraulic components may occur if the oil supply is not maintained.

7. Use a common method to disable the engine to prevent the engine from starting. Crank the starter for several seconds. Do not to exceed the engine manufacturer's recommendation. Wait 30 seconds and then crank the engine a second time as stated above. This operation helps remove air from the system lines. Refill the reservoir to recommended full oil level.
8. When charge pressure begins to appear, enable and start engine. Let the engine run for a minimum of 30 seconds at low idle to allow the air to work itself out of the system. Check for leaks at all line connections and listen for cavitation. Check for proper fluid level in reservoir.

**⚠ Caution**

Air entrapment in oil under high pressure may damage hydraulic components.

**⚠ Caution**

Do not run at maximum pressure until system is free of air and fluid has been thoroughly filtered.

9. When adequate charge pressure is established, increase engine speed to normal operating rpm to further purge residual air from the system.
10. Shut off engine. Connect pump control. Start engine, checking to be certain pump remains in neutral. Run engine at normal operating speed and carefully check for forward and reverse control operation.
11. Continue to cycle between forward and reverse for at least five minutes to bleed all air and flush system contaminants out of loop.

Normal charge pressure fluctuation may occur during forward and reverse operation.

12. Check that the reservoir is full. Remove charge pressure gauge. The pump is now ready for operation.



Pressure measurements

Required tools

The service procedures described in this manual can be performed using common mechanic's hand tools. Special tools, if required, are shown. When testing system pressures, calibrate pressure gauges frequently to ensure accuracy. Use snubbers to protect gauges.

Port locations and gauge installation

The following table and drawing show the port locations and gauge sizes needed.

Port information

Port identifier	Port size	Wrench size	Pressure obtained	Gauge size, bar [psi]
Case drain	1 1/16-12 UNF 2B	15 mm internal hex	Case drain	10 [100]
Port A, Port B	1 1/16-12 UNF 2B	N/A	System pressure	600 [10,000]
Charge inlet	7/8-14 UNF 2B	N/A	Charge pressure	50 [1000]

Port locations

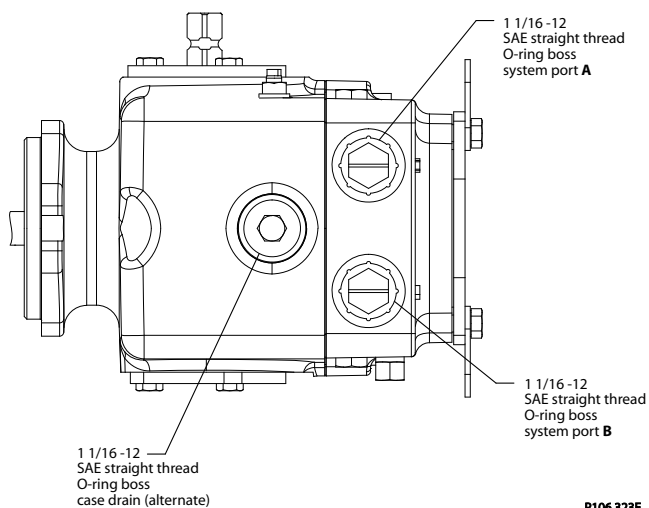
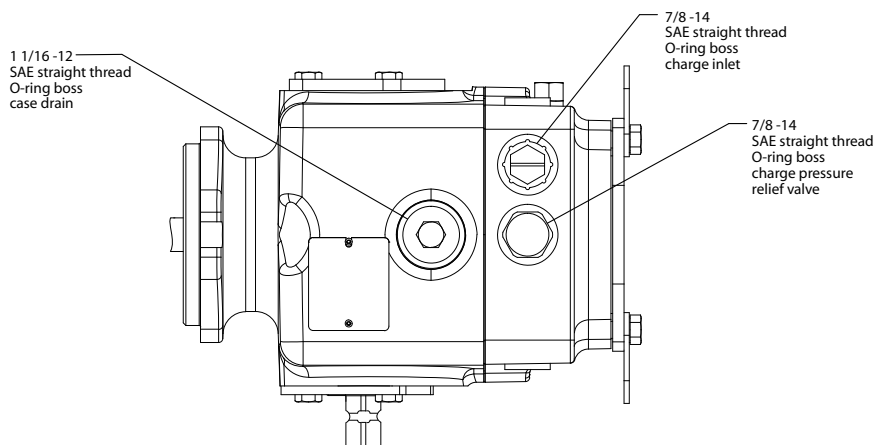

P106 323E

## Troubleshooting

### Overview

This section provides general steps to follow if undesirable system conditions are observed. Follow the steps listed until the problem is solved. Some of the items will be system specific. For areas covered in this manual, a section is referenced. Always observe the safety precautions listed in [Safety precautions](#), and related to your specific equipment.

**⚠ Warning**

Unintended movement of the machine or mechanism may cause injury to the technician or bystanders. To protect against unintended movement, secure the machine or disable/disconnect the mechanism while servicing.

### System operating hot

Item	Description	Action
Oil level in reservoir.	Insufficient hydraulic fluid will not meet cooling demands of system.	Fill reservoir to proper level.
Heat exchanger.	Heat exchanger not sufficiently cooling the system.	Check air flow and input air temperature for heat exchanger. Clean, repair or replace heat exchanger.
Charge pressure.	Low charge pressure will overwork system.	Measure charge pressure. Inspect and adjust or replace charge relief valve. Inspect charge pump. Repair or replace charge pump.
Charge pump inlet vacuum.	High inlet vacuum will overwork system. A dirty filter will increase the inlet vacuum. Inadequate line size will restrict flow.	Check charge inlet vacuum. If high, inspect inlet filter and replace as necessary. Check for adequate line size, length or other restrictions
System relief pressure settings.	If the system relief valves are worn, contaminated or, valve settings are too low, the relief valves will be overworked.	Verify settings of high pressure relief valves and replace valves as necessary.
System pressure.	Frequent or long term operation over system relief setting will create heat in system	Measure system pressure. If pressure is too high, reduce loads.

### Transmission operates normally in one direction only

Item	Description	Action
Control linkage	Control linkage operating improperly	Repair/replace control linkage
Interchange high pressure relief valves	Interchanging the high pressure relief valves will show if the problem is related to the valve function.	If the problem changes direction, replace the valve that does not operate correctly.
Ensure bypass valve is closed.	Open bypass will cause both directions to be inoperative.	Close/repair bypass function.

### System will not operate in either direction

Item	Description	Action
Ensure bypass valve is closed.	If bypass valve is open, the system loop will be depressurized.	Close bypass valve.
Charge pressure with pump in neutral	Low charge pressure insufficient to recharge system loop	Measure charge pressure with the pump in neutral. If pressure is low, go to Pump charge relief valve

**Troubleshooting**

Item	Description	Action
Charge pressure with pump in stroke	Low charge pressure resulting from elevated loop leakage.	Isolate pump from motor by blocking system ports. With pump in partial stroke and engaged for only a few seconds, check pump charge pressure. Low charge pressure indicates a malfunctioning pump. Continue to next step. Good charge pressure indicates a malfunctioning motor or other system component. Check motor charge relief operation (if present).
Pump charge relief valve.	A pump charge relief valve that is leaky, or contaminated, or set too low will depressurize the system.	Adjust or replace pump charge relief valve as necessary
Charge pump inlet filter.	A clogged filter will under supply system loop.	Inspect filter and replace if necessary.
Charge pump.	A malfunctioning charge pump will provide insufficient charge flow.	Repair or replace the charge pump.
System pressure	Low system pressure does not provide enough power to move load	Measure system pressure. Continue to next step.
System relief valves	Defective high pressure relief valves cause system pressure to be low	Repair or replace high pressure relief valves.

**System noise or vibration**

Item	Description	Action
Reservoir oil level	Low oil level leads to cavitation.	Fill reservoir.
Aeration of the oil/pump inlet vacuum	Air in system decreases efficiency of units and controls. Air in system is indicated by excessive noise in pump, foaming in oil, and hot oil.	Find location where air is entering into the system and fix. Check that inlet line is not restricted and is proper size.
Cold oil	If oil is under cold conditions, it may be too viscous for proper function and pump cavitates	Allow the oil to warm up to its normal operating temperature with engine at idle speed.
Pump inlet vacuum	High inlet vacuum causes noise/cavitation.	Check that inlet line is not restricted and is proper size. Check filter and bypass valves (if present).
Shaft couplings	A loose shaft coupling will cause excessive noise.	Replace loose shaft coupling. Replace pump or motor.
Shaft alignment	Misaligned shafts creates noise	Align shafts.
Charge/system relief valves	Unusual noise may indicate sticking valves. Possible contamination.	Clean/replace valves and test pump. May be a normal condition.

**Sluggish system response**

Item	Description	Action
Oil level in reservoir	Low oil level will cause sluggish response	Fill reservoir
High pressure relief valves	Incorrect pressure settings will affect system reaction time	Adjust or replace high pressure relief valves
Low prime mover speed	Low engine speed will reduce system performance	Adjust engine speed
Air in system	Air in system will produce sluggish system response	Fill tank to proper level. Cycle system slowly for several minutes to remove air from system
Pump inlet vacuum	Inlet vacuum is too high resulting in reduced system pressure.	Measure charge inlet vacuum. Inspect line for proper sizing. Replace filter. Confirm proper bypass operation.

## Adjustments

### Pump adjustment

This section offers instruction on inspection and adjustment of pump components. Read through the entire topic before beginning a service activity. Refer to [Pressure measurements](#) on page 17, for location of gauge ports and suggested gauge size.

### Standard procedures, inspections, and adjustments

 **Caution**

---

Contamination can damage internal components and void the manufacturer's warranty. Take precautions to ensure system cleanliness when removing and reinstalling system lines

---

1. With the prime mover off, thoroughly clean all dirt and grime from the outside of the pump.
2. If removing the pump, tag each hydraulic line connected to the pump. If hydraulic lines are disconnected, plug each open port, to ensure that dirt and contamination do not get into the pump.
3. Ensure the surrounding areas are clean and free of contaminants such as dirt and grime.
4. Inspect the system for contamination.
5. Look at the hydraulic fluid for signs of system contamination, oil discoloration, foam in the oil, sludge, or small metal particles.
6. If there are signs of contamination in the hydraulic fluid, all filters must be replaced and the hydraulic system must be drained and filled with the correct hydraulic fluid.
7. Flush the lines before replacing the hydraulic fluid.
8. Before re-installing the pump, perform a leakage test per Sauer-Danfoss leakage test HPP 112.

### Charge pressure relief valve adjustments

The following procedure explains how to check proper operation of the charge pressure relief valve.

---

Correct charge pressure is the measured pressure minus case drain pressure.

---

Adjustments

1. Validate that external charge pump is operating properly.
2. Install a 50 bar [1000 psi] pressure gauge (tee) in charge pressure inlet port. Install a 10 bar [100 psi] gauge at one of the case pressure ports. Operate the system with the pump in neutral (zero displacement) when measuring charge pressure.
3. Verify correct charge pressure per model code. Pressure measurements assume 5 Gal(US)/Min. charge flow, a reservoir temperature of 50°C (120°F), and are referenced to case pressure.

*Charge pressure relief valve*

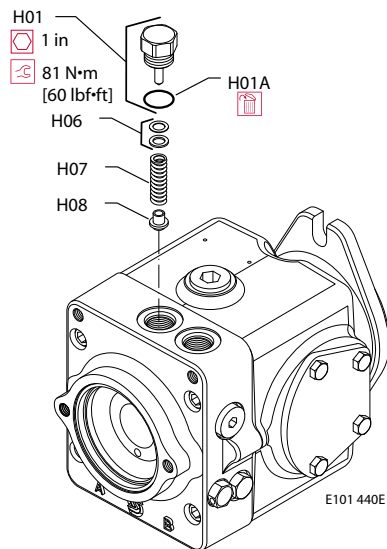

Pressure listed in model code assumes a charge flow of 19 l/min [5 Gal(US)/Min]. At higher charge flows, the charge pressure will rise over the rated setting.

4. If measured pressure is not correct, disassemble valve and look for signs of wear or contamination. Refer to [Charge pressure relief valve](#) on page 31, for wrench sizes and torque settings.
5. If valve is worn, replace entire valve.
6. Valve may be adjusted using available shim kit.
7. When the desired charge pressure setting is achieved, remove the gauges.

## Adjustments

### System check and HPRV

Whenever an HPRV valve has been replaced or opened, the pump should be operated in its full range of functions to ensure proper machine operation. The HPRV valves are pre-set at the factory, no adjustment is possible.

#### Checking for proper HPRV valve operation

For suspected HPRV valve malfunction, replace valve with identical relief setting and test operation of pump.

*HPRV valves*

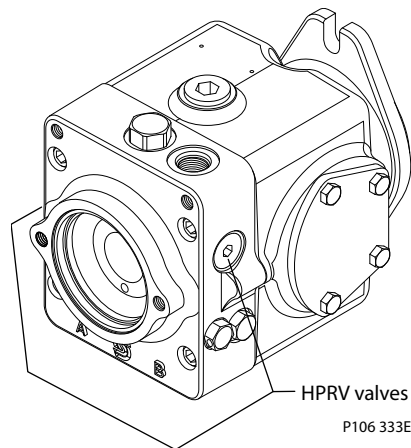

### Loop flushing valve

The loop flushing valve is not adjustable. If loop flushing malfunction is suspected, disassemble valve and check for worn, damaged or scored components. Replace parts if necessary. Refer to [Loop flushing valve](#) on page 32 for disassembly procedures.

*Loop flushing valve*

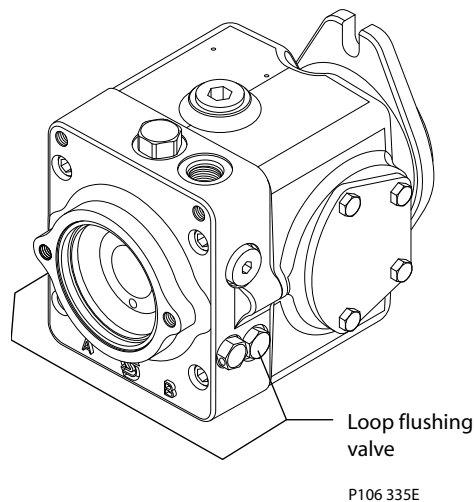

Adjustments

Neutral return mechanism

The neutral return mechanism is designed to mechanically return the pump to zero displacement. A cam allows precise zero displacement adjustment. If pump does not return to neutral, loosen locknut and turn adjusting screw until creep is eliminated. Torque locknut to 22 Nm [16 lbf·ft]. If neutral adjustment is not possible, pump teardown is necessary. See your nearest Danfoss Global Service Provider.

Neutral return adjustment

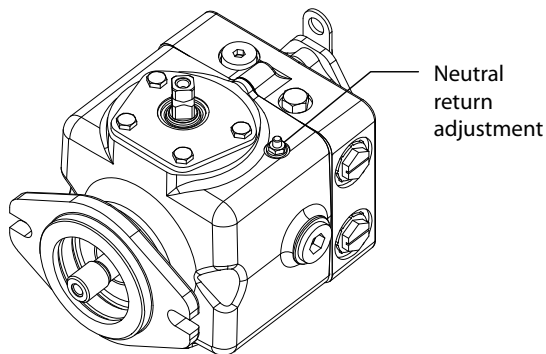

P106 336E

Neutral return adjusting screw

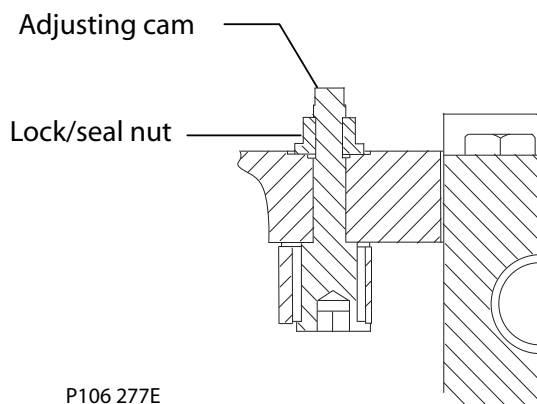

P106 277E

Neutral return mechanism

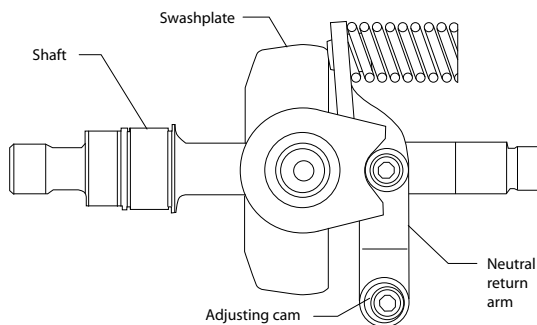

P106 278E

## Adjustments

### Neutral return adjustment

1. For propel applications, raise the wheels off the ground and secure the vehicle so you can operate it safely. Other applications: take necessary steps to ensure you can operate the machine safely during this procedure.
2. Remove the control linkage and check for creep. If the wheels/ mechanism move while the control linkage is disconnected, loosen the locknut and turn the adjusting screw clockwise or counterclockwise. You will achieve maximum adjustment with only 1/4 turn in either direction.
3. If creep is eliminated by adjustment, torque the locknut to 22 N•m [16 lbf•ft] while holding the adjustment screw secure. If creep cannot be eliminated, then the pump requires major repair. Remove the unit and refer to Sauer-Danfoss Global Service Partner for repairs.

### Leveling swashplate with pump installed on machine

Leveling the swashplate (adjusting neutral return mechanism) with the pump installed on the machine is the same procedure as adjusting on the test stand. A cam allows precise zero displacement adjustment. Block wheels off the ground. Disconnect control linkage from pump trunion. If machine creeps, loosen locknut and turn adjusting screw until creep is eliminated. If neutral adjustment is not possible, pump teardown is necessary. See your nearest Danfoss Global Service Provider.

---

[It may be necessary to disconnect the control linkage to eliminate possible linkage drag.](#)

---



Minor repair

Input shaft and seal

**Shaft seal removal**

1. Orient pump with the shaft pointing up.
2. Remove retaining ring (D03) using retaining ring pliers to release the shaft seal components. Discard retaining ring.

**! Caution**

Do not damage the housing bore, shaft or bearing when removing the shaft and shaft seal.

3. Remove the seal support washer (D02). Use a small hook if necessary.
4. Install a special fitting with air chuck into a case drain port.
5. Use air pressure to push out shaft seal (D01). Discard seal.
6. Remove special fitting and replace with original plug.

*Remove shaft /seal/bearing*

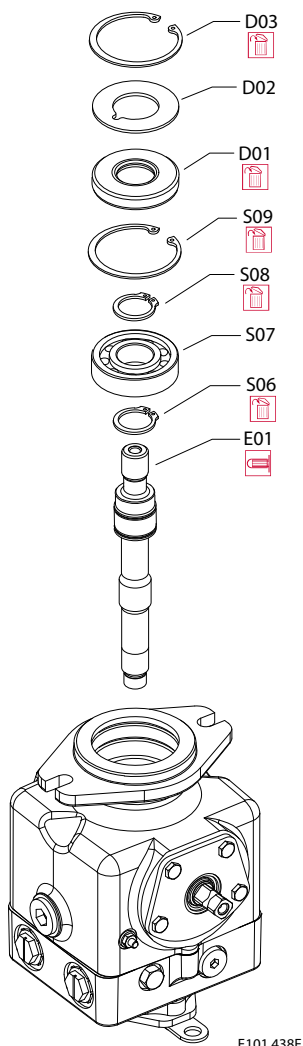

E101 438E

## Minor repair

**Input shaft removal**

1. Remove retaining ring (S09) using retaining ring pliers.
2. Pull shaft (E01) with bearing (S07) out of the pump. If necessary, tap on the shaft to dislodge it from the internal pump components.

**⚠ Caution**

If the shaft is to be replaced without complete pump disassembly, do not move or rotate the pump once the shaft is removed. This may dislodge internal components, making reassembly impossible.

3. Remove retaining ring (S08) using retaining ring pliers.
4. Press bearing off the shaft using the inner race.
5. Remove retaining ring (S06) from the shaft using retaining ring pliers.

**Shaft inspection**

Check to see that the shaft (E01) and its splines are straight and free of damage or heavy wear. Inspect the shaft surface where it meets the shaft seal. Replace the shaft if a groove exists at the sealing land surface that may let dirt into or hydraulic fluid out of the unit. Clean the sealing area with a nonabrasive material if necessary. Lubricate the shaft with a light coat of hydraulic fluid before re-assembly.

*Inspect shaft*

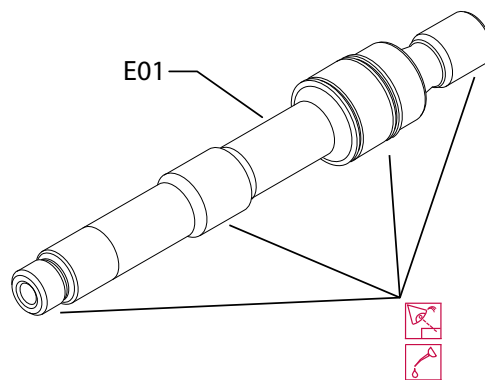

P106 291E

## Minor repair

**Shaft bearing inspection**

Clean bearing with a solvent and lubricate with hydraulic fluid. Inspect for wear, or pitting.

---

Replace bearing if cleaning exposes wear or damage to bearing.

---

*Inspect shaft bearing*

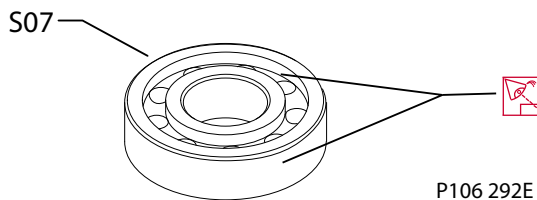
**Shaft and seal reassembly**

1. Orient pump with the shaft end pointing up.
2. Install first bearing retaining ring (S06) using retaining ring pliers.
3. Lubricate bearing (S07) with hydraulic fluid. Press bearing onto shaft by applying force to inner race.
4. Install second bearing retaining ring (S09) using retaining ring pliers.
5. For protection, cover end of shaft with installation sleeve or packaging tape.
6. Install shaft (S01) with bearing into housing. It may be necessary to tap the shaft to seat the bearing.

**! Caution**

---

Do not damage the housing bore, shaft or bearing when installing the shaft and shaft seal.

---

7. Using retaining ring pliers, install first seal retaining ring (S09).

Minor repair

- 8. Lubricate the seal (D01) using hydraulic fluid. Press seal into housing until it bottoms out. Press evenly to avoid binding and damaging the seal.
- 9. Install the seal support washer (D02).
- 10. Install the second seal retaining ring (D03) using retaining ring pliers.

*Install shaft /seal/bearing*

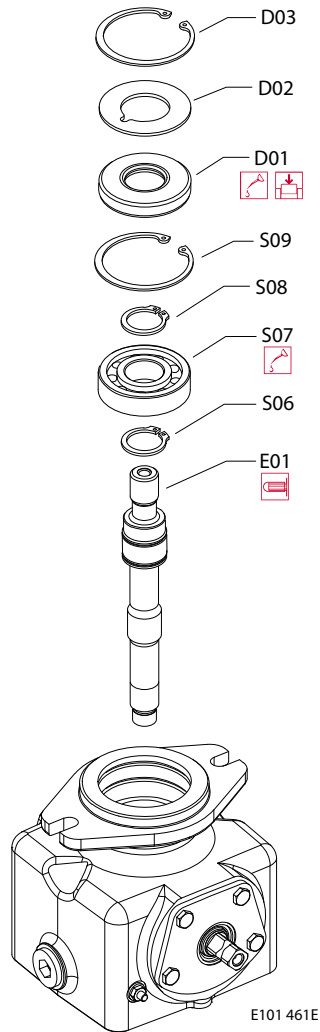

Minor repair

Trunion seal

**Removal**

1. Remove four trunion cover bolts (N03) using a 13 mm hex wrench.
2. Remove trunion cover (N01). Remove and discard O-ring (N04).
3. Press the lip seal (N02) out of the trunion cover (N01); discard.

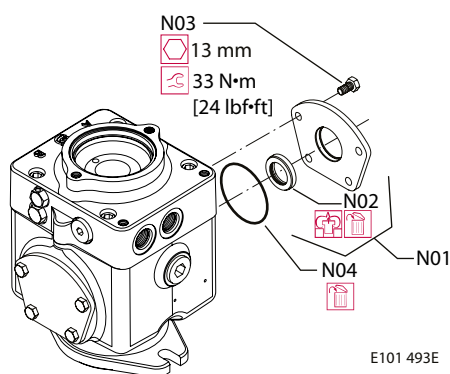

**Inspection**

Inspect seal land on trunion shaft and trunion cover for rust, wear, or contamination. Polish seal land on trunion shaft if necessary.

**Reassembly**

1. Press new trunion seal (N02) into cover (N03).
2. Install new O-ring (N04). Retain with petroleum jelly.
3. Cover the trunion shaft with an installation sleeve or wrap with packaging tape to prevent damage to seal.
4. Install trunion cover and seal assembly (N01) to housing.
5. Install four trunion cover bolts using a 13mm hex wrench. Torque to 33 N·m [24 lbf·ft].

Minor repair

High Pressure Relief Valves

**Removal**

1. Mark the location of each system check relief valve for proper reassembly.
2. Using a 5/16 internal hex wrench, remove system check relief valves (M10) and (M20).
3. Remove and discard O-rings (M022) and (M023).

*Disassemble system check relief valves*

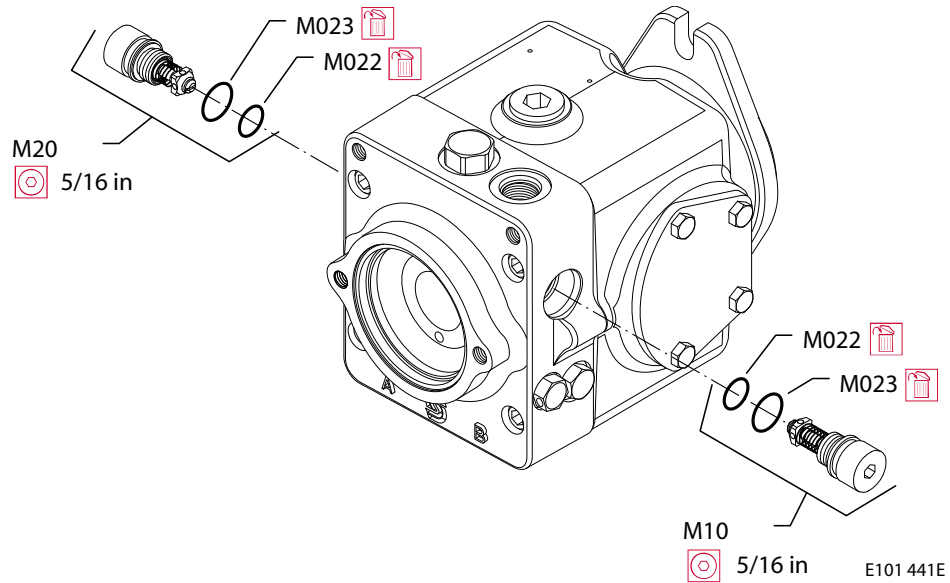

**Inspection**

1. Inspect plug and cartridge. Replace O-rings before reassembly
2. Inspect internal parts of cartridge. If internal parts are worn or damaged, replace entire cartridge.

**Reassembly**

1. Lubricate and install new O-rings (M022) and (M023) onto each system check relief valve (M10) and (M20).
2. Install the system check relief valves in their original location as noted during disassembly.
3. Use a 5/16 in internal hex wrench to torque valves to 81 N·m [60 lbf·ft].

Minor repair

Charge pressure relief valve

**Removal**

1. Using a 1 in hex wrench, remove the charge pressure relief valve plug (H01). Discard O-ring (H01A).
2. Charge relief valve shim kit (H06) remains in plug (H01). Remove shims by tapping the plug on the workbench.
3. Use a magnet to remove the spring (H07).
4. Use a magnet to remove the charge relief poppet (H08).

*Charge pressure relief valve*

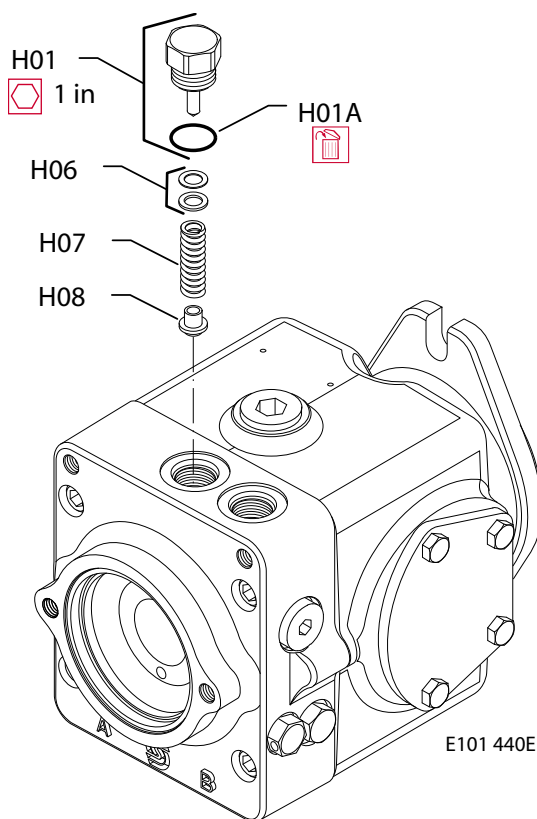

**Inspection**

1. Inspect charge relief valve plug for wear or damage. Replace O-ring before reassembly
2. Inspect shim kit.
3. Inspect the spring. Replace spring if it is warped or bent.
4. Inspect charge relief valve poppet.

**Reassembly**

1. Insert charge relief valve poppet (H08) and spring (H07) into endcap.
2. Install shims (H06) into charge relief valve plug (H01).
3. Lubricate and install a new O-ring (H01A) onto the charge relief valve plug.
4. Install charge relief valve plug using a 1 in hex wrench. Torque to 81-203 N•m [60-150 lbf•ft].

Minor repair

Loop flushing valve

**Removal**

1. Using a 11/16 in hex wrench, remove the loop flushing valve plugs (J06). Discard Oring (J06A).
2. Use a magnet to remove springs (J07).
3. Use a magnet to remove loop flush spool (J08).

*Disassemble loop flushing valve*

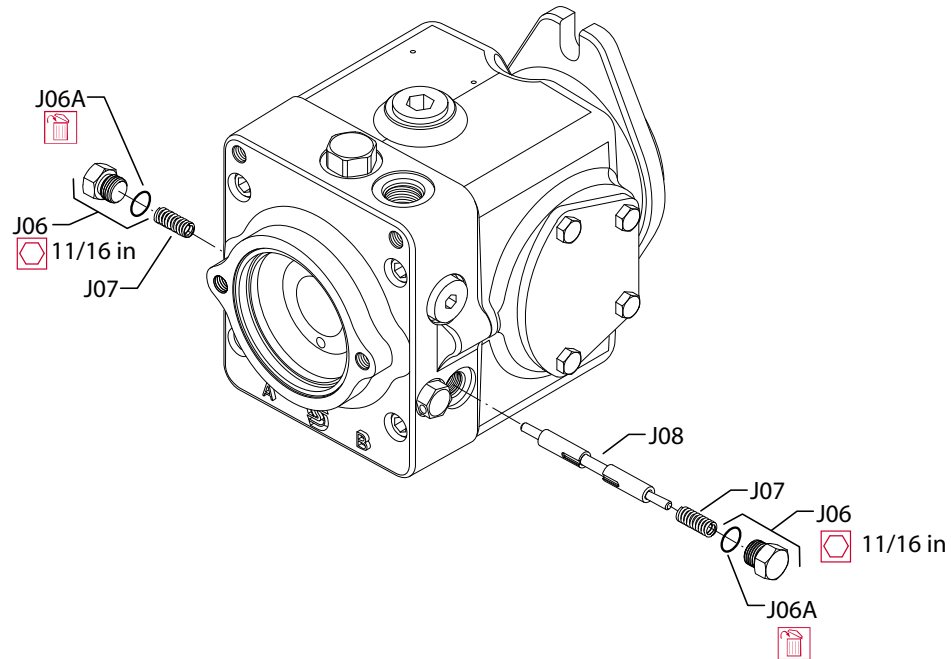

E101 442E

**Inspection**

1. Inspect loop flushing valve plugs for damage or wear. Replace O-rings before reassembly.
2. Inspect the springs. Replace if warped or bent.
3. Inspect loop flush spool. If worn or damaged, replace the loop flush spool.

**Reassembly**

1. Insert loop flush spool (J08) and springs (J07) into endcap.
2. Lubricate and install new O-rings (J06A) onto loop flushing valve plug (J06).
3. Thread the loop flushing valve plugs into the housing.
4. Torque to 45 N·m [33 lbf·ft] using a 11/16 in hex wrench.



Minor repair

Bypass valve

**Removal**

Using a 5/8 in hex wrench, remove the bypass valve cartridge (L01). Discard Oring (1003) and backup ring (1002).

*Bypass valve*

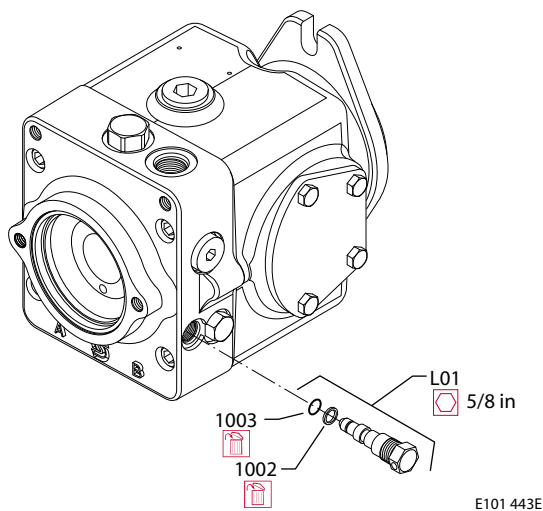

**Inspection**

1. Inspect plug and cartridge. Replace O-rings before reassembly
2. Inspect internal parts of cartridge. If internal parts are worn or damaged, replace entire cartridge.

**Reassembly**

1. Install new O-ring (1003) and backup ring (1002).
2. Install the bypass valve cartridge (L01) using a 5/8 in hex wrench.
3. Torque to 20 N·m [15 lbf·ft].

Minor repair

Coupling

**Removal**

1. Position pump so endcap is on top.
2. Remove coupling (T03). Use a small hook if necessary.

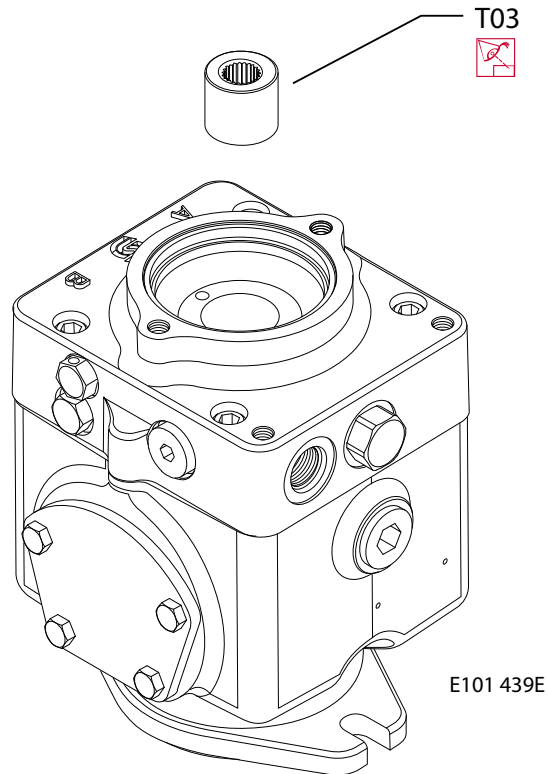

**Inspection**

Check coupling for abnormal or excessive wear. Look for cracks that indicate coupling fatigue. If wear or damage is found, replace coupling.

**Reassembly**

Lubricate and install coupling (T03).

Torque chart

Fasteners and plugs

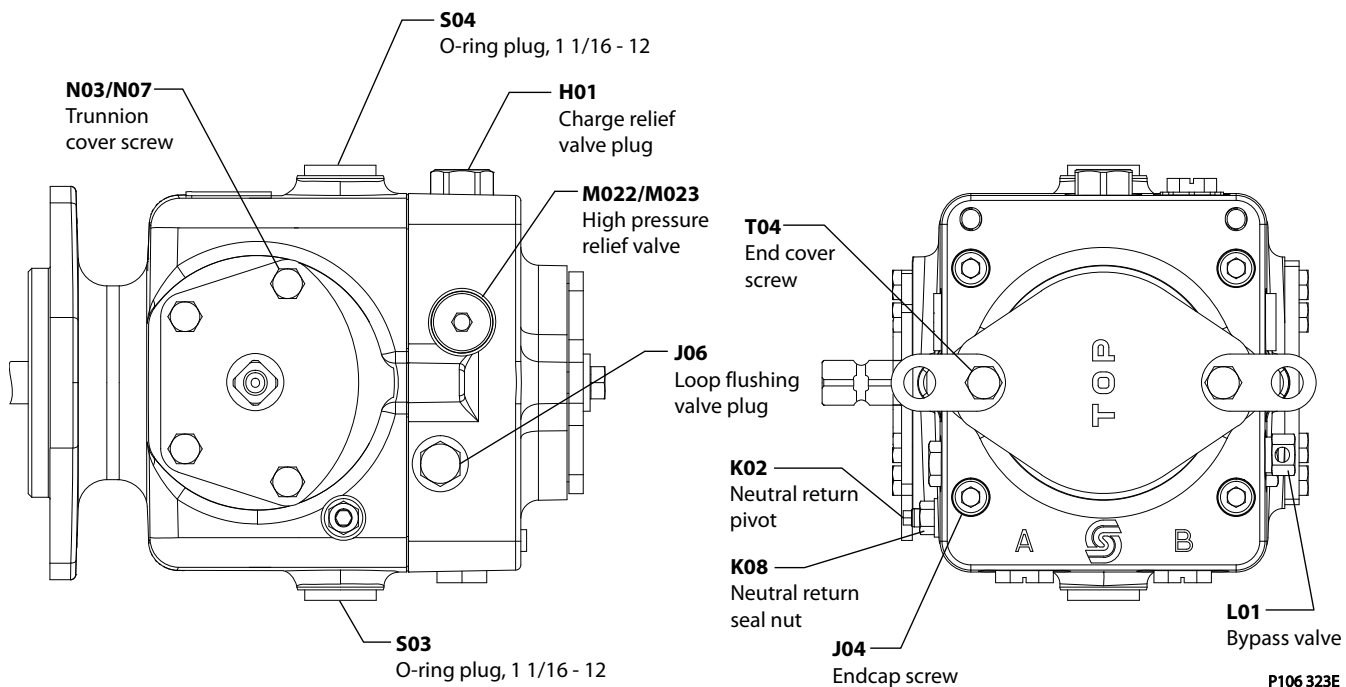

P106 323E

Fastener size and torque chart

Item	Fastener	Wrench size	Torque
H01	Charge relief valve plug	1 in	81-203 N•m [60-150 lbf•ft]
J04	Endcap screw	8 mm internal hex	54 N•m [40 lbf•ft]
J06	Loop flushing valve plug	11/16 in	45 N•m [33 lbf•ft]
K02	Neutral return pivot	1/4 in	N/A
K08	Neutral return seal nut	13 mm	22 N•m [16 lbf•ft]
L01	Bypass valve	11/16 in	20 N•m [15 lbf•ft]
M022/M023	High pressure relief valve	5/16 in internal hex	81 N•m [60 lbf•ft]
N03/N07	Trunnion cover screw	13 mm	33 N•m [24 lbf•ft]
T04	End cover screw	9/16 in	44 N•m [32 lbf•ft]

Plug size and torque chart

Item	O-ring plug	Wrench size	Torque
S03, S04	1 1/16 - 12	15 mm internal hex	69 N•m [51 lbf•ft]



**Products we offer:**

- Bent Axis Motors
- Closed Circuit Axial Piston Pumps and Motors
- Displays
- Electrohydraulic Power Steering
- Electrohydraulics
- Hydraulic Power Steering
- Integrated Systems
- Joysticks and Control Handles
- Microcontrollers and Software
- Open Circuit Axial Piston Pumps
- Orbital Motors
- PLUS+1® GUIDE
- Proportional Valves
- Sensors
- Steering
- Transit Mixer Drives

**Danfoss Power Solutions** is a global manufacturer and supplier of high-quality hydraulic and electronic components. We specialize in providing state-of-the-art technology and solutions that excel in the harsh operating conditions of the mobile off-highway market. Building on our extensive applications expertise, we work closely with our customers to ensure exceptional performance for a broad range of off-highway vehicles.

We help OEMs around the world speed up system development, reduce costs and bring vehicles to market faster.

Danfoss – Your Strongest Partner in Mobile Hydraulics.

**Go to [www.powersolutions.danfoss.com](http://www.powersolutions.danfoss.com) for further product information.**

Wherever off-highway vehicles are at work, so is Danfoss. We offer expert worldwide support for our customers, ensuring the best possible solutions for outstanding performance. And with an extensive network of Global Service Partners, we also provide comprehensive global service for all of our components.

Please contact the Danfoss Power Solution representative nearest you.

**Comatrol**

[www.comatrol.com](http://www.comatrol.com)

**Schwarzmueller-Inverter**

[www.schwarzmueller-inverter.com](http://www.schwarzmueller-inverter.com)

**Turolla**

[www.turollaocg.com](http://www.turollaocg.com)

**Hydro-Gear**

[www.hydro-gear.com](http://www.hydro-gear.com)

**Daikin-Sauer-Danfoss**

[www.daikin-sauer-danfoss.com](http://www.daikin-sauer-danfoss.com)

Local address:

**Danfoss Power Solutions (US) Company**  
2800 East 13th Street  
Ames, IA 50010, USA  
Phone: +1 515 239 6000

**Danfoss Power Solutions GmbH & Co. OHG**  
Krokamp 35  
D-24539 Neumünster, Germany  
Phone: +49 4321 871 0

**Danfoss Power Solutions ApS**  
Nordborgvej 81  
DK-6430 Nordborg, Denmark  
Phone: +45 7488 2222

**Danfoss Power Solutions Trading (Shanghai) Co., Ltd.**  
Building #22, No. 1000 Jin Hai Rd  
Jin Qiao, Pudong New District  
Shanghai, China 201206  
Phone: +86 21 3418 5200

Danfoss can accept no responsibility for possible errors in catalogues, brochures and other printed material. Danfoss reserves the right to alter its products without notice. This also applies to products already on order provided that such alterations can be made without changes being necessary in specifications already agreed. All trademarks in this material are property of the respective companies. Danfoss and the Danfoss logotype are trademarks of Danfoss A/S. All rights reserved.