

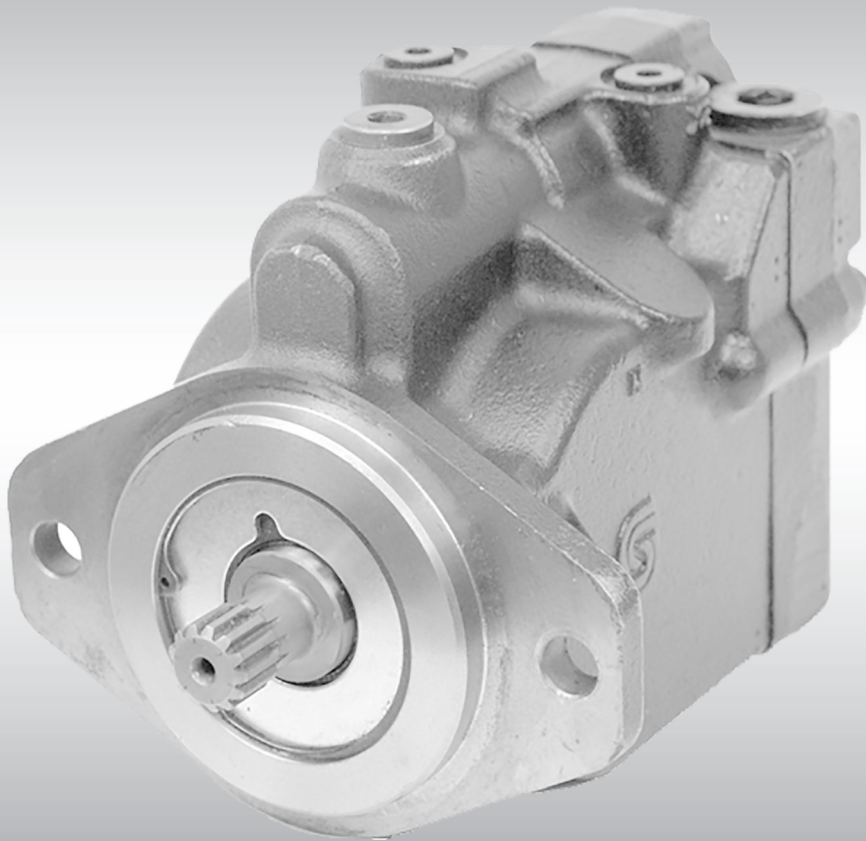

Service Manual

Closed Circuit Axial Piston K and L Frame Variable Motors, SAE Mount



Revision history*Table of revisions*

Date	Changed	Rev
November 2014	Danfoss layout	DA
May 2013	Add Anti-Cavitation Valve	CB
October 2010	Minor edits, new back page	CA
November 2006	Added loop flushing valve	B
July 2004	First edition	A

Contents

Introduction

Overview.....4
 Safety precautions.....4
 Unintended machine movement.....4
 Flammable cleaning solvents.....4
 Fluid under pressure.....4
 Personal safety.....4
 Symbols used in Danfoss literature.....5
 Design.....5
 The System circuit.....6

Technical specifications

Overview.....7
 Features and options.....7
 Specifications.....7
 Operating parameters.....7
 Fluid specifications.....7

Features

Displacement limiter.....9
 Output shafts.....9
 Controls.....9
 Control orificing.....9

Pressure measurements

Required tools.....10
 Port locations and gauge installation.....10

Initial start-up procedures

General12
 Start-up procedure.....12

Fluid and filter maintenance

Recommendations.....13

Troubleshooting

Excessive noise and / or vibration.....14
 System operating hot.....14
 Won't shift or slow to shift.....14

Minor repair

Shaft seal replacement.....15
 Remove the shaft seal.....15
 Inspect the components.....15
 Install the new shaft seal.....15
 Speed sensor replacement.....15
 Remove the speed sensor.....15
 Install the new speed sensor.....16
 Speed sensor adjustment.....17
 Adjustment and troubleshooting.....17
 Loop flushing valve.....17
 Remove the loop flushing valve.....17
 Inspect the components.....18
 Install the loop flushing valve.....18
 Anti-Cavitation Valve.....19
 Remove the anti-cavitation valve.....19
 Inspect the components.....19
 Install the anti-cavitation valve.....19

Introduction

Overview

This manual includes information for the installation, maintenance, and minor repair of the K and L Frame SAE Mount Variable Motors. The manual includes a description of the units and their individual components, troubleshooting information, and minor repair procedures. Performing installation, maintenance, and minor repair of K and L Frame Variable Motors according to the procedures in this manual will not affect your warranty.

Performing minor repairs requires the unit to be removed from the vehicle/machine. Thoroughly clean the unit before beginning maintenance, or repair activities. Since dirt and contamination are the greatest enemies of any type of hydraulic equipment, follow cleanliness requirements strictly. This is especially important when changing the system filter and when removing hoses or plumbing.

A worldwide network of Danfoss Authorized Service Centers (ASCs) is available for major repairs. Major repairs require the removal of the unit's endcap, which voids the warranty unless done by an ASC. Danfoss ASCs are trained by the factory and certified on a regular basis. You can locate your nearest ASC using the distributor locator at www.danfoss.com.

Safety precautions

Always consider safety precautions before beginning a service procedure. Protect yourself and others from injury. Take the following general precautions whenever servicing a hydraulic system.

Unintended machine movement

 **Warning**

Unintended movement of the machine or mechanism may cause injury to the technician or bystanders. To protect against unintended movement, secure the machine or disable / disconnect the mechanism while servicing.

Flammable cleaning solvents

 **Warning**

Some cleaning solvents are flammable. To avoid possible fire, do not use cleaning solvents in an area where a source of ignition may be present.

Fluid under pressure

 **Warning**

Escaping hydraulic fluid under pressure can have sufficient force to penetrate your skin causing serious injury and/or infection. This fluid may also be hot enough to cause burns. Use caution when dealing with hydraulic fluid under pressure. Relieve pressure in the system before removing hoses, fittings, gauges, or components. Never use your hand or any other body part to check for leaks in a pressurized line. Seek medical attention immediately if you are cut by hydraulic fluid.

Personal safety

 **Warning**

Protect yourself from injury. Use proper safety equipment, including safety glasses, at all times.

Introduction

Symbols used in Danfoss literature

 WARNING may result in injury	 Tip, helpful suggestion
 CAUTION may result in damage to product or property	 Lubricate with hydraulic fluid
 Reusable part	 Apply grease / petroleum jelly
 Non-reusable part, use a new part	 Apply locking compound
 Non-removable item	 Inspect for wear or damage
 Option - either part may exist	 Clean area or part
 Superseded - parts are not interchangeable	 Be careful not to scratch or damage
 Measurement required	 Note correct orientation
 Flatness specification	 Mark orientation for reinstallation
 Parallelism specification	 Torque specification
 External hex head	 Press in - press fit
 Internal hex head	 Pull out with tool – press fit
 Torx head	 Cover splines with installation sleeve
 O-ring boss port	 Pressure measurement/gauge location or specification

The symbols above appear in the illustrations and text of this manual. They are intended to communicate helpful information at the point where it is most useful to the reader. In most instances, the appearance of the symbol itself denotes its meaning. The legend above defines each symbol and explains its purpose.

Design

K and L Frame Variable Motors (KV/LV) are low to medium power, two-position axial piston motors incorporating an integral servo piston. They are designed for operation in both open and closed circuit applications. KV/LV motors have an SAE-B, two bolt mounting configuration. The standard control is a direct acting single line hydraulic control. The integral servo piston controls motor displacement.

The motors are spring biased to maximum displacement and hydraulically shifted to minimum displacement. Minimum and maximum displacement can be set with fixed internal stops. The large diameter servo piston allows smooth acceleration and deceleration with relatively large circuit orificing.

The motors are ideally configured for installations requiring compact packaging and optimized plumbing, such as wheel ends. One face of the motor contains all hydraulic porting. Two standard porting configurations are available: twin radial (side) or axial (end) O-ring boss main ports.

Introduction

Cross section view

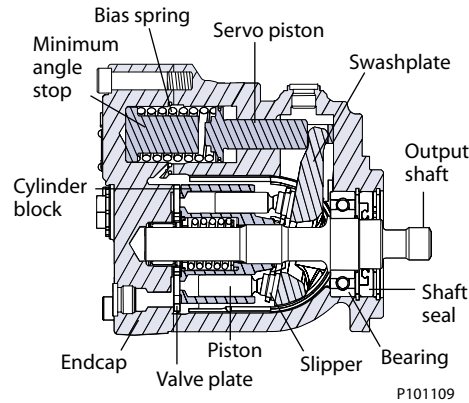

The System circuit

The circuit below shows the KV/LV motor in a simple closed-loop hydrostatic propel application. The motor is driven by a Series 42 medium power axial piston pump with manual displacement control. The motor shown uses a single line hydraulic displacement control. Control pressure applied through an external control valve shifts the motor to minimum displacement; spring force returns the motor to maximum displacement in the absence of control input.

System circuit diagram

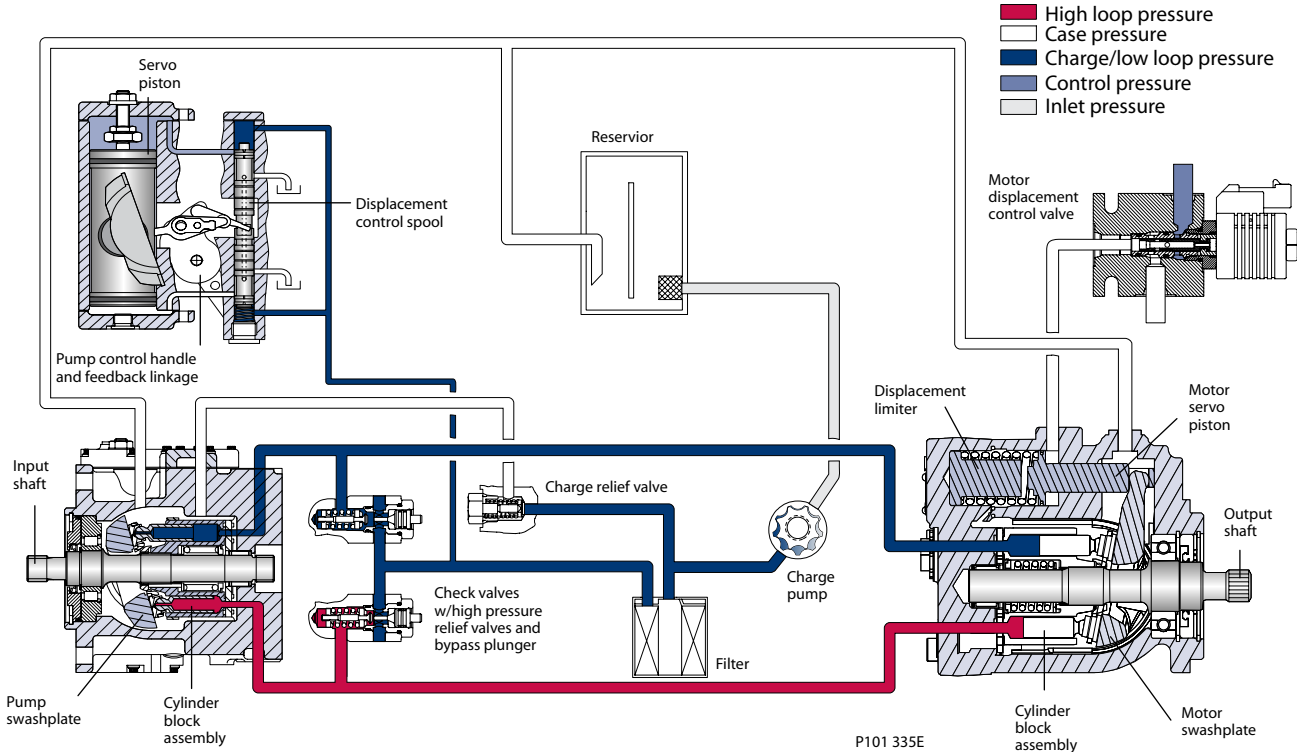

Technical specifications
Overview

Specifications and operating parameters for KV/LV motors are given here for reference.

Features and options

Mount	SAE-B (LV/KV)	Cartridge (LC/KC)
Motor type	Inline, axial piston, positive displacement, two-speed variable motors	
Displacement	L: 25, 30, or 35 cm ³ [1.50, 1.83, or 2.14 in ³] K: 38 or 45 cm ³ [2.32 or 2.75 in ³]	
Rotation	Bidirectional	
Installation position	Discretionary: Housing must always be filled with hydraulic fluid	
Porting	SAE O-ring boss, axial or twin radial	SAE O-ring boss, twin radial
Output shafts	Splined 13 or 15 tooth 16/32 pitch, 0.875 in. straight keyed, and 1:8 taper	Splined 13 or 15 tooth 16/32 pitch
Control options	Single or dual line hydraulic control	Single line hydraulic control
Displacement limiter	Fixed maximum and minimum displacement limiters available	
Speed sensor	Available on L Frame SAE-B motors, in development* on K frame and cartridge motors	
Loop Flushing Valve	Available	

Specifications

Parameter	Unit	L25	L30	L35	K38	K45
Displacement (maximum)	cm ³ [in ³]	25 [1.50]	30 [1.83]	35 [2.14]	38 [2.32]	45 [2.75]
Weight (cartridge and SAE-B)	kg [lb]	15.4 [34]				
Mass moment of inertia of rotating components	kg·m ² [slug·ft ²]	0.001666 [0.001229]	0.001582 [0.001167]	0.001530 [0.001128]	0.002326 [0.001716]	0.002286 [0.001687]
Theoretical torque	N·m/bar [lbf·in/1000psi]	0.40 [244]	0.48 [293]	0.56 [347]	0.60 [366]	0.72 [439]

Operating parameters

Parameter	Unit	L25	L30	L35	K38	K45
System pressure	continuous	210 [3045]	175 [2540]	140 [2030]	210 [3045]	175 [2540]
	maximum	415 [6020]	350 [5075]	300 [4350]	415 [6020]	350 [5075]
Speed limit (at max. disp)	continuous	3400	3500	3600	3600	3500
	maximum	3950	4150	4300	4000	3900
Speed limit (at min. disp)	continuous	4400	4450	4500	4650	4500
	maximum	5000	5150	5300	5200	5050
Case pressure	continuous	2 [29]				
	maximum	6 [87]				

Fluid specifications

Ratings and data are based on operation with premium petroleum-based hydraulic fluids containing oxidation, rust, and foam inhibitors.

Technical specifications

Parameter	Unit	Minimum	Continuous	Maximum
Viscosity	mm ² /sec (cSt) [SUS]	7 [47]	12-60 [70-278]	1600 [7500]
Temperature	°C [°F]	-40 [-40]	82 [180]	104 [220]
Cleanliness		ISO 4406 Class 18/13 or better		
Filtration efficiency	suction filtration	$\beta_{35-44}=75$ ($\beta_{10} \geq 1.5$)		
	charge filtration	$\beta_{15-20}=75$ ($\beta_{10} \geq 10$)		

Features

Displacement limiter

KV/LV motors are available with a minimum angle stop. This displacement limiter is not adjustable.

Displacement limiter

Minimum angle stop

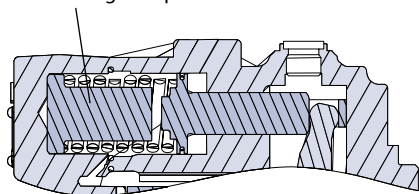

P104 242E

Output shafts

KV/LV motors have one of the following shafts. For dimensions, refer to L and K Frame Variable Motors Technical Information, 520L0627.

- 13 tooth spline
16/32 pitch
ANSI B92.1 1970-Class 5
- Ø 22.225 mm [.875 in]
Straight keyed
- Ø 22.225 mm [.875 in]
1:5 Taper
- 15 tooth spline
16/32 pitch
ANSI B92.1 1970-Class 5

Controls

KV/LV motors are designed to operate in two positions: maximum and minimum displacement. The motors are spring biased to maximum displacement and hydraulically shifted to minimum displacement. KV/LV motors can operate with a single line or dual line control.

Control input pressure limits

Single line control	14 to 69 bar [200 to 1000 psi]
Dual line control	14 to 35 bar [200 to 500 psi]

Pressure applied at port X1 shifts the motor to minimum displacement. Pressure at X2 can assist the shift to maximum displacement. Refer to the table above for control input pressure range.

Control orificing

Motors with single line controls can have optional, internal supply and drain orifices installed to regulate control response times.

Motors with dual line controls rely on external valving and orificing to regulate shift speeds.

Pressure measurements

Required tools

The service procedures described in this manual can be performed using common mechanic's hand tools. Special tools, if required are shown. Calibrate pressure gauges frequently to ensure accuracy. Use snubbers to protect gauges.

Port locations and gauge installation

For economical reasons, the KV/LV motors do not contain any designated gauge installation ports. All pressure measurements can be obtained by installing tee fittings to the connections at the locations listed in the table / drawing below. Recommended gauge sizes are also listed.

Port information

Port identifier	Size	Pressure obtained	Gauge size, bar [psi]
X1	[0.5625]-18 UNF-2B	Control signal	600 [10 000]
X2	[0.5625]-18 UNF-2B	Control signal	600 [10 000]
L1	[0.750]-16 UNF-2B	Case drain	10 [100]
L2	[0.750]-16 UNF-2B	Case drain	10 [100]
A	[1.0625]-12 UNF-2B	System pressure	600 [10 000]
B	[1.0625]-12 UNF-2B	System pressure	600 [10 000]

Twin radial port locations

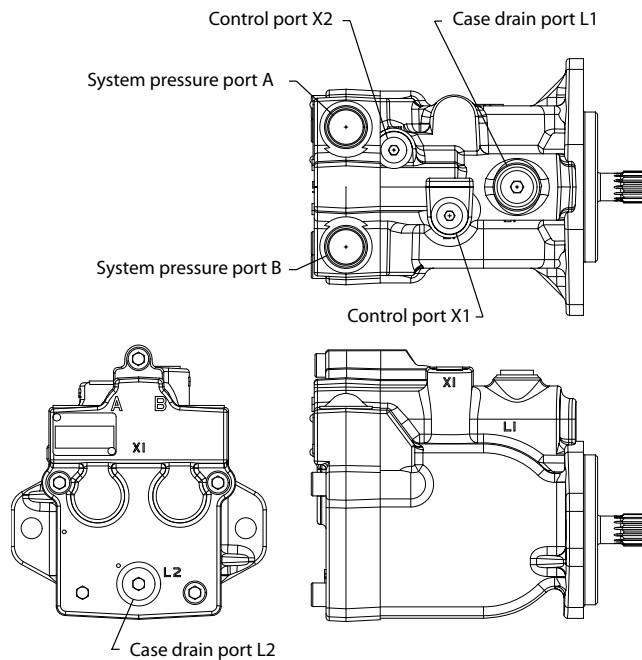

P104 240E

Pressure measurements

Axial port locations

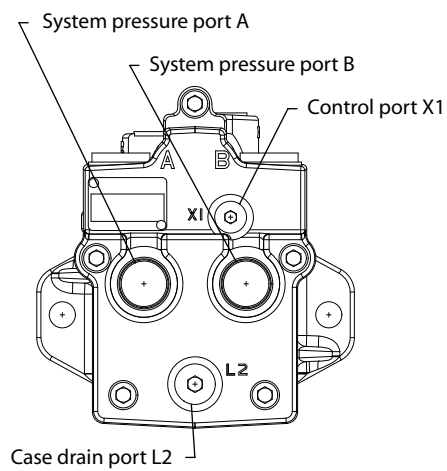

P104 242E

Initial start-up procedures

General

Follow this procedure when starting-up a new motor installation or when restarting an installation in which the motor has been removed.

 **Warning**

Unintended movement of the machine or mechanism may cause injury to the technician or bystanders. To protect against unintended movement, secure the machine or disable ~~it~~ disconnect the mechanism while servicing.

Prior to installing the motor, inspect for damage incurred during shipping. Make certain all system components (reservoir, hoses, valves, fittings, heat exchanger, etc.) are clean prior to filling with fluid.

Start-up procedure

1. Fill the reservoir with recommended hydraulic fluid. Always filter fluid through a 10 micron filter when pouring into the reservoir. Never reuse hydraulic fluid.
2. Fill the inlet line leading from the pump to the reservoir. Check the inlet line for properly tightened fittings and be certain it is free of restrictions and air leaks.
3. Fill the pump and motor housing with clean hydraulic fluid. Pour filtered oil directly into the upper most case drain port.
4. To ensure the pump and motor stay filled with oil, install case drain lines into the upper most case drain ports.
5. Install a 0 to 35 bar [0 to 500 psi] gauge in the charge pressure gauge port of the pump to monitor system pressure during start up.

[Follow recommendations in the vehicle / machine operator's manual for prime mover start up procedures.](#)

6. While watching the pressure gauge, jog the prime mover or run at the lowest possible speed until system pressure builds to normal levels (minimum 11 bar [160 psi]). Once system pressure is established, increase to full operating speed. If system pressure is not maintained, shut down the prime mover, determine cause, and take corrective action. Refer to *Troubleshooting*, page 13.
 7. Operate the hydraulic system for at least fifteen minutes under light load conditions.
 8. Check and adjust control settings as necessary after installation.
 9. Shut down the prime mover and remove the pressure gauge. Replace plug at the charge pressure gauge port.
 10. Check the fluid level in the reservoir; add clean filtered fluid if necessary.
- The motor is now ready for operation.

Fluid and filter maintenance

Recommendations

To ensure optimum life of KV/LV products, perform regular maintenance of the fluid and filter. Contaminated fluid is the main cause of unit failure. Take care to maintain fluid cleanliness when servicing.

Check the reservoir daily for proper fluid level, the presence of water, and rancid fluid odor. Fluid contaminated by water may appear cloudy or milky or free water may settle in the bottom of the reservoir. Rancid odor indicates the fluid has been exposed to excessive heat. Change the fluid immediately if these conditions occur. Correct the problem immediately.

Change the fluid and filter per the vehicle / machine manufacturer's recommendations or at these intervals:

Fluid and filter change interval

Reservoir type	Max oil change interval
Sealed	2000 hours
Breather	500 hours

Change the fluid more frequently if it becomes contaminated with foreign matter (dirt, water, grease, etc.) or if the fluid is subjected to temperature levels greater than the recommended maximum.

[Dispose of used hydraulic fluid properly. Never reuse hydraulic fluid.](#)

Change filters whenever the fluid is changed or when the filter indicator shows that it is necessary to change the filter. Replace all fluid lost during filter change.

Troubleshooting
Excessive noise and / or vibration

Item	Description	Action
Check oil level in reservoir and oil supply to the motor.	Insufficient hydraulic fluid could lead to cavitation that would cause system noise.	Fill the reservoir to the proper level and ensure that oil supply to the motor is adequate and the lines are unobstructed.
Check for air in the system.	Air trapped within the system lines, or the motor itself, could result in cavitation that would cause system noise.	Ensure that all of the system lines and components are purged of air.
Inspect the output shaft couplings.	A loose or incorrect shaft coupling will produce vibrations that could result in system noise.	Ensure that the correct coupling is used and that it fits properly onto the shaft.
Inspect the output shaft alignment.	Misaligned shafts create excessive frictional vibration that could result in system noise.	Ensure that the shafts are properly aligned.
Hydraulic oil viscosity above limits.	Viscosity above acceptable limits will result in cavitation that would lead to system noise.	Replace hydraulic oil with appropriate fluid for operating conditions. Refer to publication 5200L0463 for information on fluid selection.

System operating hot

Item	Description	Action
Check oil level in reservoir and oil supply to the pump.	Insufficient amount of hydraulic fluid will not meet the cooling demands of the system.	Fill the reservoir to the proper level.
Inspect the heat exchanger, (if so equipped).	If the heat exchanger fails, or becomes obstructed, it may not meet the cooling demands of the system.	Ensure that heat exchanger is receiving adequate air flow and that the heat exchanger is in good operating condition. Repair or replace as necessary.
Check the system relief valves.	If a system relief valve becomes unseated for an extended period of time or fails for any other reason, the system could become overheated.	Repair or replace any malfunctioning relief valves as applicable and verify that the loads on the machine are not excessive.

Won't shift or slow to shift

Item	Description	Action
Check the signal line to the servo control port.	Obstructed or restricted flow through the servo control signal lines could result in <i>slow shift</i> or <i>no shift</i> conditions within the motor.	Ensure that the signal lines are not obstructed or restricted and that signal pressure is adequate to shift the motor.
Check that the correct supply and drain orifices are properly installed, and are not obstructed.	Supply and drain orifices determine the shift rate of the motor. The smaller the orifice, the longer the time it takes to shift the motor. Obstruction will also increase shift times.	Ensure that the proper control orifices are installed in the motor and verify that they are not obstructed. Clean or replace as necessary.

Minor repair

Shaft seal replacement

Remove the shaft seal

1. Remove the snap ring (B005) retaining the shaft seal and support washer.
2. Remove the support washer (M004).
3. Carefully pry out the shaft seal (M003).

To avoid damaging the shaft during removal, install a large sheet metal screw into the chuck of a slide hammer. Drive the screw into the seal surface and use the slide hammer to pull the seal.

4. Discard the seal.

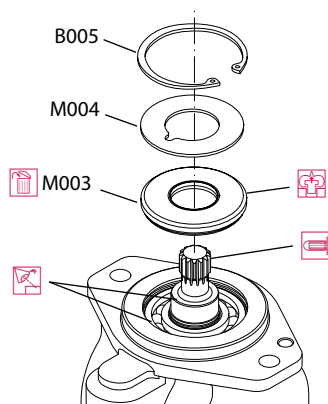
Replacing the shaft seal

E101 061

Inspect the components

Inspect the new seal, the motor housing seal bore, and the sealing area on the shaft for rust, wear, and contamination. Polish the shaft and clean the housing if necessary.

Install the new shaft seal

1. Cover the shaft splines with an installation sleeve to protect the shaft seal during installation.
2. Install a new shaft seal with the cupped side facing the motor. Press seal into housing until it bottoms out. Press evenly to avoid binding and damaging the seal.
3. Install seal support washer.
4. Install snap ring.
5. Remove the installation sleeve.

Speed sensor replacement

Remove the speed sensor

1. Disconnect the speed sensor electrical connector.
2. Using an 11/16 wrench, loosen the locknut.
3. Using a 1/2 inch wrench, remove the speed sensor and o-ring from the motor.

Minor repair

Replacing the speed sensor

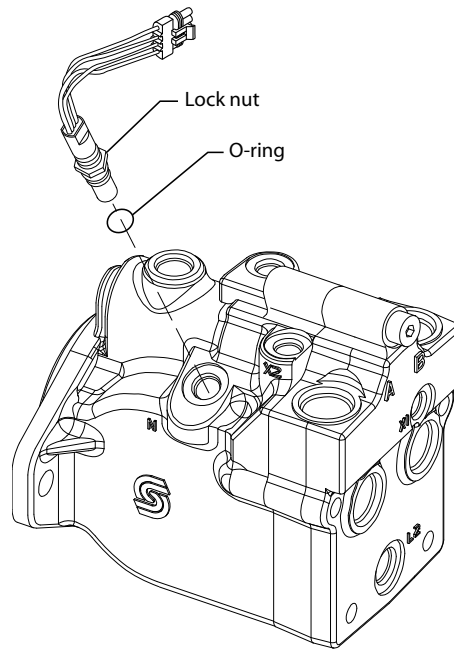

P104 359E

Install the new speed sensor

1. Turn speed sensor with o-ring in (CW) by hand until bottom end gently touches the speed ring.
2. Back out speed sensor (CCW) 1/4 turn. Continue backing out until the flats are 22° either side of the motor shaft center line (20° to 30° is acceptable). Do not back out more than 3/4 turn from touching bottom.
3. Using a 1/2 inch wrench to hold the speed sensor, torque the lock nut to 13 N•m [10 lbf•ft] with an 11/16 inch wrench.
4. Plug in electrical connection and start machine to test for proper operation.

Minor repair

Installing the speed sensor

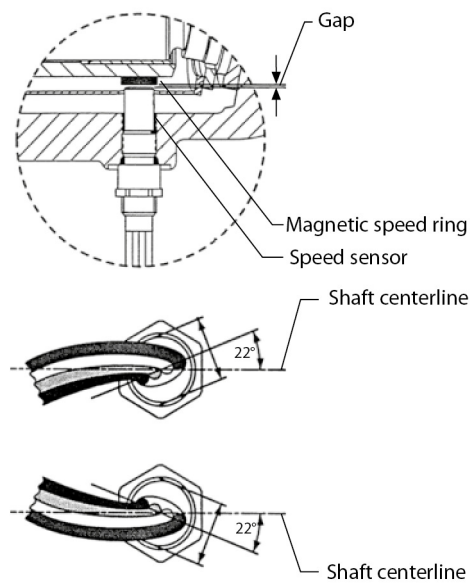

P104358

Speed sensor adjustment

Adjustment and troubleshooting

1. Wire configuration

- Red=Power
- White=Speed signal
- Black=Ground (common)
- Green=Direction

2. Speed signal

Check for speed output using a Volt Ohm Meter (VOM). Place VOM across the ground and speed pins or terminals, (Black=Ground, White=Speed Signal) and set VOM to the DC Volt scale and low range. To check for an output, turn pump or motor very slowly by hand or check output just as the prime mover is coming to a stop. Note a voltage pulse at meter. It will likely be difficult to read exact, simply note a pulse (approximately 60 pulses per rev). If there is no indication of a pulse, repeat installation steps and recheck.

3. Directional signal

Check for a direction signal change using a VOM. Use the same VOM setup as in the above speed signal check. Turn the motor slowly and note a polarity change (\pm) on the VOM display as you change the motor direction.

Loop flushing valve

Remove the loop flushing valve

1. Using a 11/16 in internal hex wrench remove plug (E020) and (E010).
2. Using a 1/4 in hex wrench remove plug (E042).
3. Remove O-rings (E020B, E042A, and E010B).

Minor repair

4. Using pliers, remove centering springs (E041, E020C, and E010C).
5. Remove spring retaining washers (E020D and E010D).
6. Remove shift spool (E030).
7. Remove orifice poppet (E040).

Loop flushing valve

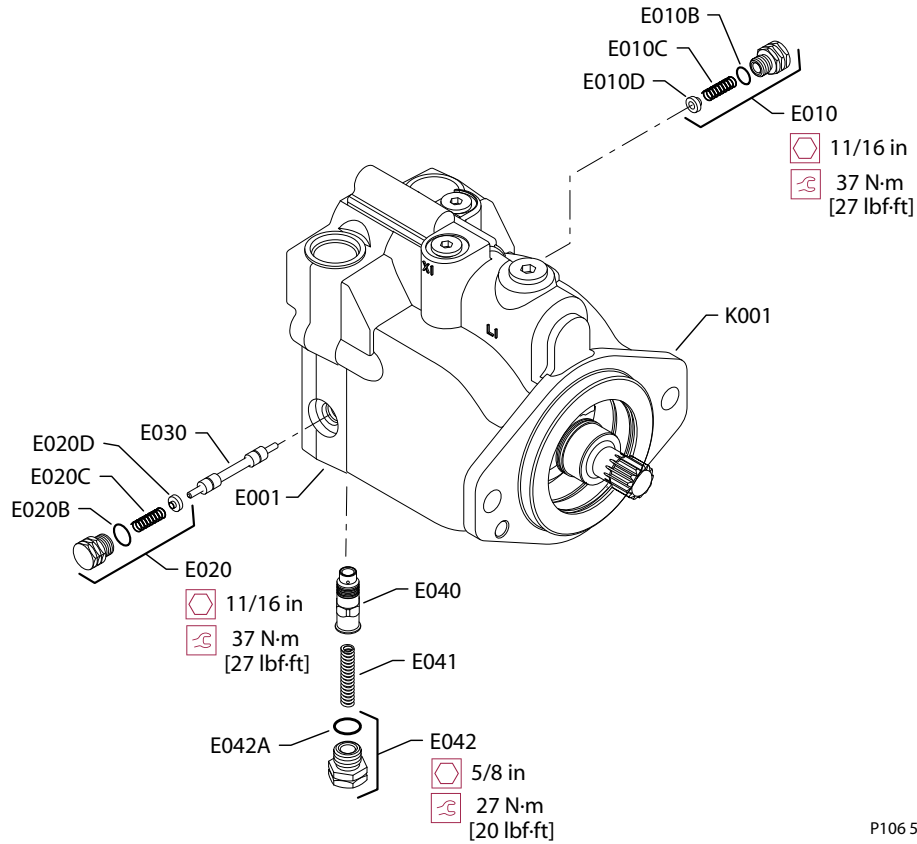

P106 512E

Inspect the components

Inspect new O-rings and the sealing area for rust, wear, or contamination. Also check springs and poppet for wear.

Install the loop flushing valve

1. Install orifice poppet (E040).
2. Install shift spool (E030).
3. Install spring retaining washers onto springs (E020D and E010D).
4. Carefully install centering springs (E041, E020C, and E010C).
5. Install new O-rings (E010B, E020B, and E042A).
6. Using a 1/4 in hex wrench torque plug (E042) to X N·m [X ft·lbs].
7. Using a 11/16 in internal hex, torque plugs (E010 and E020) to X N·m [X lbf·ft].

Minor repair

Anti-Cavitation Valve

Remove the anti-cavitation valve

The anti-cavitation valve is installed into the high pressure port. The high pressure port depends on motor rotation. If rotation is counterclockwise, the high pressure port is A. If rotation is clockwise, the high pressure port is B.

1. Using a 5/16 in internal hex wrench remove valve plug (E061). Remove and discard O-ring (E063).
2. Remove spring (E012) and relief valve (E011) from end cap.
3. Using a 5/16 in internal hex wrench remove plug (E020). Remove and discard O-ring (E020A).

Anti-cavitation valve

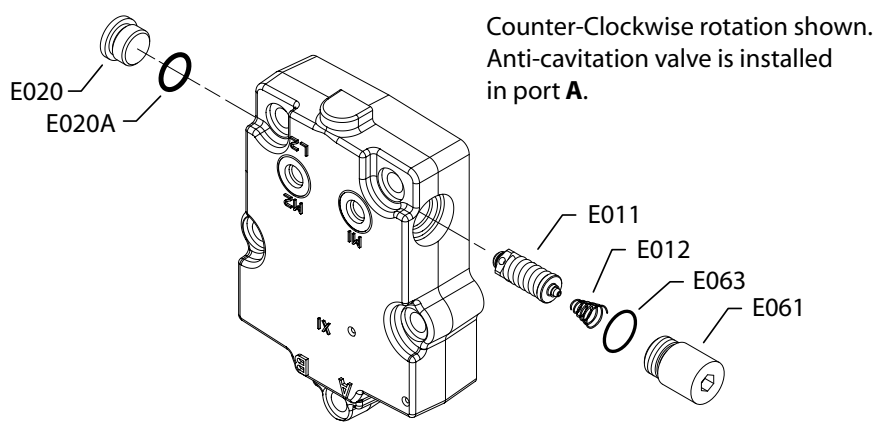

P108 714E

Inspect the components

Inspect sealing area for rust, wear, or contamination. Check spring (E012) and relief valve (E011) for wear and damage. Relief valve (E011) is non-serviceable, replace as complete unit if damaged.

Install the anti-cavitation valve

1. Lubricate and insert relief valve (E011) and spring (E012) in original location.
2. Lubricate and install new O-ring (E063) on valve plug (E061).
3. If needed lubricate and install new O-ring (E020A) on plug (E020).
4. Using a 5/16 inch internal hex wrench to install valve plug (E061) into port with relief valve (E011). Torque to 80 N•m [59 lbf•ft].
5. If needed using a 5/16 inch internal hex wrench to install plug (E020) into port without relief valve (E011). Torque to 80 N•m [59 lbf•ft].



Products we offer:

- Bent Axis Motors
- Closed Circuit Axial Piston Pumps and Motors
- Displays
- Electrohydraulic Power Steering
- Electrohydraulics
- Hydraulic Power Steering
- Integrated Systems
- Joysticks and Control Handles
- Microcontrollers and Software
- Open Circuit Axial Piston Pumps
- Orbital Motors
- PLUS+1® GUIDE
- Proportional Valves
- Sensors
- Steering
- Transit Mixer Drives

Danfoss Power Solutions is a global manufacturer and supplier of high-quality hydraulic and electronic components. We specialize in providing state-of-the-art technology and solutions that excel in the harsh operating conditions of the mobile off-highway market. Building on our extensive applications expertise, we work closely with our customers to ensure exceptional performance for a broad range of off-highway vehicles.

We help OEMs around the world speed up system development, reduce costs and bring vehicles to market faster.

Danfoss – Your Strongest Partner in Mobile Hydraulics.

Go to www.powersolutions.danfoss.com for further product information.

Wherever off-highway vehicles are at work, so is Danfoss. We offer expert worldwide support for our customers, ensuring the best possible solutions for outstanding performance. And with an extensive network of Global Service Partners, we also provide comprehensive global service for all of our components.

Please contact the Danfoss Power Solution representative nearest you.

Comatrol

www.comatrol.com

Schwarzmueller-Inverter

www.schwarzmueller-inverter.com

Turolla

www.turollaocg.com

Valmova

www.valmova.com

Hydro-Gear

www.hydro-gear.com

Daikin-Sauer-Danfoss

www.daikin-sauer-danfoss.com

Local address:

Danfoss Power Solutions (US) Company
2800 East 13th Street
Ames, IA 50010, USA
Phone: +1 515 239 6000

Danfoss Power Solutions GmbH & Co. OHG
Krokamp 35
D-24539 Neumünster, Germany
Phone: +49 4321 871 0

Danfoss Power Solutions ApS
Nordborgvej 81
DK-6430 Nordborg, Denmark
Phone: +45 7488 2222

Danfoss Power Solutions (Shanghai) Co., Ltd.
Building #22, No. 1000 Jin Hai Rd
Jin Qiao, Pudong New District
Shanghai, China 201206
Phone: +86 21 3418 5200

Danfoss can accept no responsibility for possible errors in catalogues, brochures and other printed material. Danfoss reserves the right to alter its products without notice. This also applies to products already on order provided that such alterations can be made without changes being necessary in specifications already agreed. All trademarks in this material are property of the respective companies. Danfoss and the Danfoss logotype are trademarks of Danfoss A/S. All rights reserved.