

ENGINEERING
TOMORROW

Danfoss

Service Manual

D1 High Power Open Circuit Pumps

Size 65/130/145/193/260

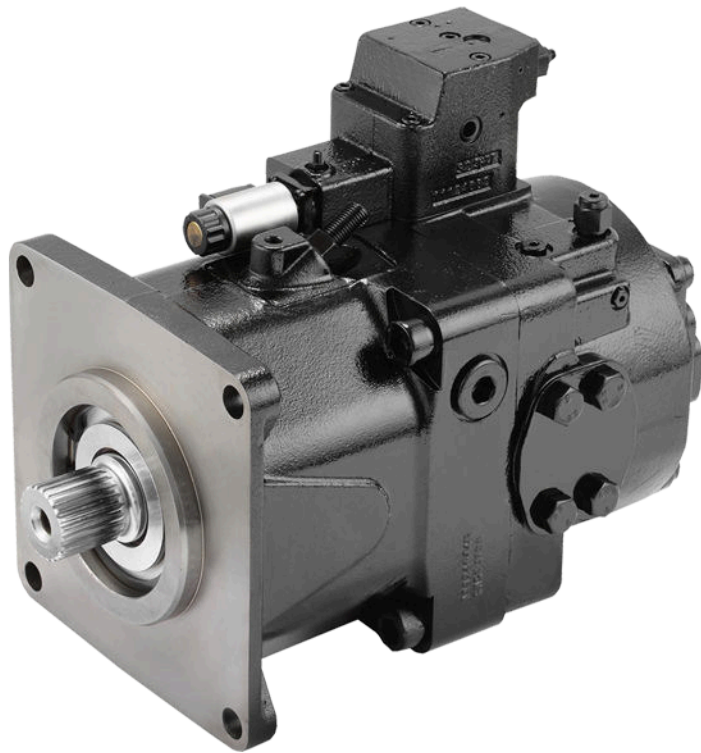

Revision history*Table of revisions*

Date	Changed	Rev
July 2019	Added 65cc size	0201
October 2018	Added Shaft Replacement	0106
July 2018	Fixed layout	0105
June 2018	Major Update	0104
October 2017	Added Size 130	0103
June 2016	Added Size 260	0102
April 2016	Converted to Danfoss layout - DITA CMS	0101
July 2015	Added 145 cc information	AB
January 2014	First edition	AA

Contents

Introduction

Overview.....	5
General instructions.....	5
Remove the unit.....	5
Keep it clean.....	5
Replace all O-rings and gaskets.....	5
Secure the unit.....	5
Safety precautions.....	5
Unintended Machine Movement.....	5
Flammable Cleaning Solvents.....	6
Fluid Under Pressure.....	6
Personal Safety.....	6
Symbols used in Danfoss literature.....	6
Design.....	6
Cross-section view.....	8

Operation

NPNN (Pressure Compensated Control).....	9
NPSN (Pressure Compensated Control + Load Sensing Control).....	11
NPNR (Pressure Compensated Control + Remote Pressure Compensated Control).....	13
TPSN (Power Control + Pressure Compensated Control + Load Sensing Control).....	15
NNES (Electric Displacement Control + Load Sensing Control).....	17
Solenoid Specification.....	19
Standard EDC Valve.....	20
NNES Priority.....	20
TPE2/TPE5 (Power Control + Pressure Compensated Control + Electric Displacement Control).....	21
TPE2/TPE5 Priority.....	21
NPE2/NPE0 (Pressure Compensated Control + Electric Displacement Control).....	22

Operating parameters

Pressure.....	23
Speed.....	23
Fluid.....	23
Viscosity.....	24
Temperature.....	24
Fluid velocity.....	24

Technical specifications

D1 pump specifications.....	25
D1P fluid specifications.....	26

Fluid and filter maintenance

Recommendations of fluid and filter maintenance.....	27
--	----

Pressure measurements

Port Locations and Gauge Installation (65).....	28
Port Locations and Gauge Installation (130/145).....	29
Port Locations and Gauge Installation (193/260).....	30

Initial start-up procedures

General.....	31
Start-up Procedure.....	31

Troubleshooting

Excessive Noise and /or Vibration.....	32
Low Pump Output Flow.....	32
No or Low System Pressure.....	32
Actuator Response is Sluggish.....	33
Pressure or Flow Instability.....	33
System Operating Hot.....	34
High Inlet Vacuum.....	34

Adjustments

Contents

Calculate Power Control Start Point Pressure and Corresponding Flow in Advance..... 35
 Electric Displacement Control Adjustment 36
 Pressure Compensated Control Adjustment..... 38
 Power Control Adjustment..... 38
 Load Sensing Control Adjustment..... 38
 Displacement Limiters Adjustment..... 42
 Adjust Displacement Limiters..... 42

Minor repairs

Shaft replacement..... 43
 Shaft removal..... 43
 Shaft installation..... 44
 Shaft Seal Replacement..... 45
 Removal..... 45
 Installation..... 45
 Auxiliary Flange and Charge Pump Replacement..... 46
 Auxiliary flange removal..... 46
 Auxiliary flange installation..... 46
 130/145..... 47
 193/260..... 48
 Control (193/260)..... 49
 Removal..... 49
 Installation..... 49
 Control (130/145)..... 51
 Shuttle Valve or Plug..... 52
 Shuttle valve or plug removal..... 52
 Shuttle valve or plug installation..... 52
 Edge Filter (260)..... 52
 Edge filter removal..... 52
 Edge filter installation..... 52
 Displacement Limiters..... 54
 Displacement limiter screw removals..... 54
 Displacement limiter screws installation..... 54
 Plug and fitting installation..... 56
 193 TPE2 control..... 56
 260 TPE2 control..... 57
 130/145 TPSN control..... 58
 Plugs and fasteners..... 59
 Fastener and torque chart..... 59
 Plug size and torque chart..... 60

Introduction

Pump service overview

This manual includes information on maintenance, troubleshooting, and minor repair of D1P pumps.

Performing minor repairs may require removal from the vehicle/machine. Thoroughly clean the unit before beginning maintenance or repair activities. Since dirt and contamination are the greatest enemies of any type of hydraulic equipment, follow cleanliness requirements strictly. This is especially important when changing the system filter and when removing hoses or plumbing.

A worldwide Global Service Partner Network is available for major repairs. Major repairs require the removal of the unit's endcap, which voids the warranty unless done by a Global Service Partner. Danfoss Global Service Partners are trained by the factory and certified on a regular basis. You can locate your nearest Global Service Partner using the distributor locator at www.danfoss.com.

For detailed technical information, refer to the [Technical Information manual](#).

General instructions

Remove the unit



If necessary, remove the unit from the vehicle/machine. Chock the wheels on the vehicle or lock the mechanism to inhibit movement. Be aware that hydraulic fluid may be under high pressure and/or hot. Inspect the outside of the pump and fittings for damage. Cap hoses after removal to prevent contamination.

Keep it clean



Cleanliness is a primary means of assuring satisfactory pump life on either new or repaired units. Clean the outside of the pump thoroughly before disassembly. Take care to avoid contamination of the system ports. Cleaning parts by using a clean solvent wash and air drying is usually adequate.

As with any precision equipment, you must keep all parts free of foreign material and chemicals. Protect all exposed sealing surfaces and open cavities from damage and foreign material. If left unattended, cover the pump with a protective layer of plastic.

Replace all O-rings and gaskets



Danfoss recommends that you replace all O-rings, seals and gaskets. Lightly lubricate all O-rings with clean petroleum jelly prior to assembly.

Secure the unit



If removed from machine, place the unit in a stable position with the shaft pointing downward. It will be necessary to secure the pump while removing and torquing fasteners and components.

Safety precautions

Unintended Machine Movement

Unintended movement of the machine or mechanism may cause injury to the technician or bystanders. Secure the machine or disable/disconnect the mechanism while servicing to protect against unintended movement.

Introduction

Flammable Cleaning Solvents

Some cleaning solvents are flammable.

Do not use cleaning solvents in an area where a source of ignition may be present to avoid possible fire.

Fluid Under Pressure

Escaping hydraulic fluid under pressure can have sufficient force to penetrate your skin causing serious injury and/or infection. This fluid may also be hot enough to cause burns.





























Relieve pressure in the system before removing hoses, fittings, gauges, or components. Never use your hand or any other body part to check for leaks in a pressurized line. Use caution when dealing with hydraulic fluid under pressure. Seek medical attention immediately if you are cut by hydraulic fluid.

Personal Safety

Protect yourself from injury whenever servicing a hydraulic system.

Use proper safety equipment, including safety glasses, at all times.

Symbols used in Danfoss literature

	WARNING may result in injury		Tip, helpful suggestion
	CAUTION may result in damage to product or property		Lubricate with hydraulic fluid
	Reusable part		Apply grease / petroleum jelly
	Non-reusable part, use a new part		Apply locking compound
	Non-removable item		Inspect for wear or damage
	Option - either part may exist		Clean area or part
	Superseded - parts are not interchangeable		Be careful not to scratch or damage
	Measurement required		Note correct orientation
	Flatness specification		Mark orientation for reinstallation
	Parallelism specification		Torque specification
	External hex head		Press in - press fit
	Internal hex head		Pull out with tool – press fit
	Torx head		Cover splines with installation sleeve
	O-ring boss port		Pressure measurement/gauge location or specification

The symbols above appear in the illustrations and text of this manual. They are intended to communicate helpful information at the point where it is most useful to the reader. In most instances, the appearance of the symbol itself denotes its meaning. The legend above defines each symbol and explains its purpose.

D1 pumps design

Danfoss D1 high power open circuit piston pumps convert input torque into hydraulic power. Rotational force is transmitted through the input shaft to the cylinder block. The input shaft is supported by roller

Introduction

bearings at the front and rear of the pump and is splined into the cylinder block . A lip-seal at the front end of the pump prevents leakage where the shaft exits the pump housing. The spinning cylinder block contains nine reciprocating pistons. Each piston has a brass slipper connected at one end by a ball joint. The slippers are held to the swashplate by the retainer. The block spring holds the cylinder block to the valve plate. The reciprocating movement of the pistons occurs as the slippers slide against the inclined swashplate during rotation. Via the valve plate, one half of the cylinder block is connected to pump inlet and the other half to pump outlet. As each piston cycles in and out of its bore, fluid is drawn from the inlet and displaced to the outlet thereby imparting power into the system circuit. A small amount of fluid is allowed to "leak" from the cylinder block / valve plate and slipper / swashplate interfaces for lubrication and cooling. Case drain ports are provided to return this fluid to the reservoir.

The volume of fluid displaced into the system circuit is controlled by the angle of the swashplate. The swashplate is forced into an inclined position (into stroke) by the bias piston and spring. The servo piston opposes the action of the bias piston and spring forcing the swashplate out of stroke.

The pump control, by varying the pressure at the servo piston, controls the displacement of fluid in the system circuit.

Introduction

D1 pump cross-section view

D1 pump

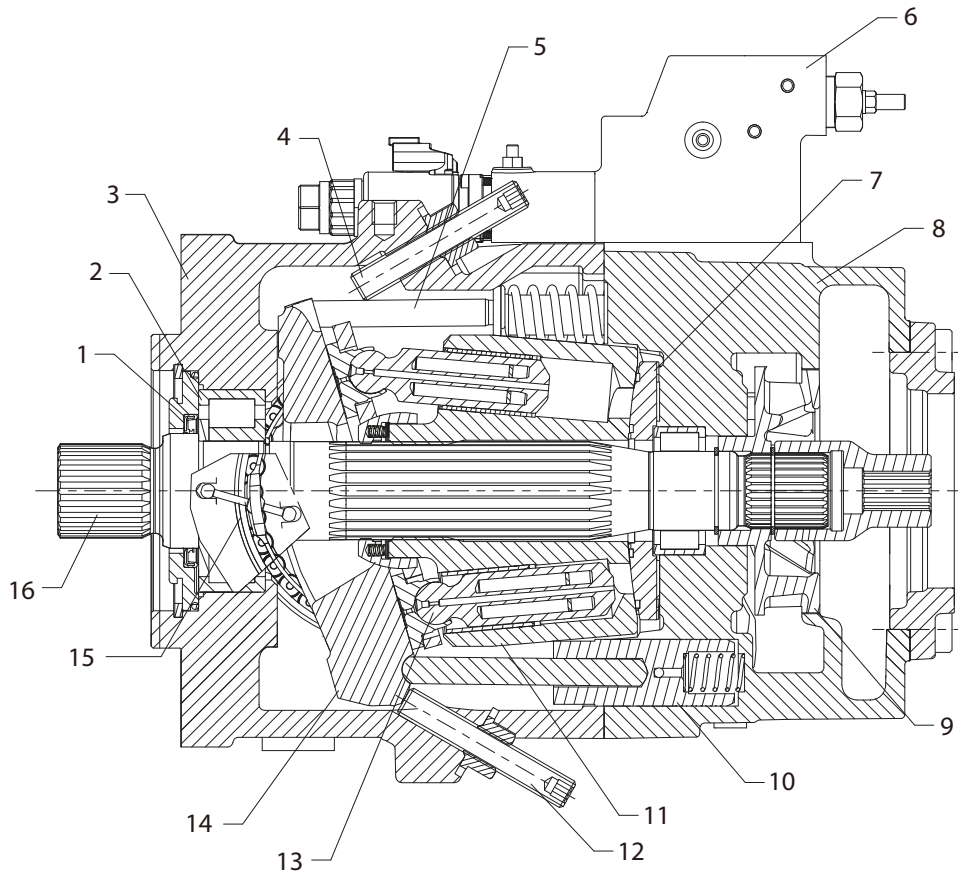

- 1. Shaft seal
- 2. Roller bearing
- 3. Housing
- 4. Minimum displacement limiter
- 5. Bias piston
- 6. Control
- 7. Valve plate
- 8. Endcap
- 9. Charge pump
- 10. Servo piston
- 11. Cylinder block
- 12. Maximum displacement limiter
- 13. Piston
- 14. Swashplate
- 15. Swashplate Bearing
- 16. Input shaft

Some internal parts may be different depending on the pump size.

Operation

NPNN (Pressure Compensated Control)

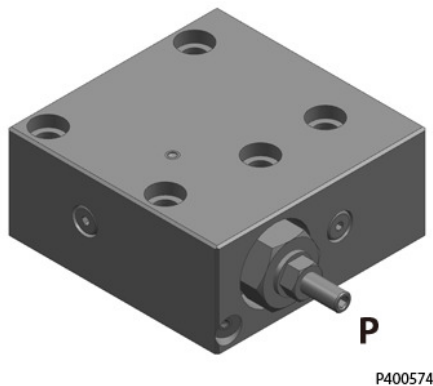

D1P 130/145/193/260+NPNN

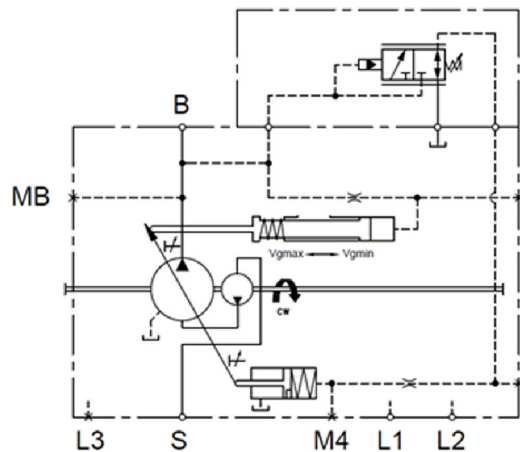

P400575

Pressure Compensated Control (P) Principle

The P control design maintains a constant pressure in the hydraulic circuit as flow varies. The P control modulates pump flow accordingly to maintain system pressure at the P setting as the P adjusting screw and spring defines.

Pressure Compensated Control (P) Operation

When system pressure, acting on the non-spring end of the P spool, overcomes the force of the P spring, the spool shifts porting system pressure to the servo piston and the swashplate angle decreases. When system pressure drops below the P setting, the P spring shifts the spool in the opposite direction connecting the servo piston to pump case and the swashplate angle increases. The swashplate is maintained at whatever angle is required to keep system pressure at the P setting.

P characteristic

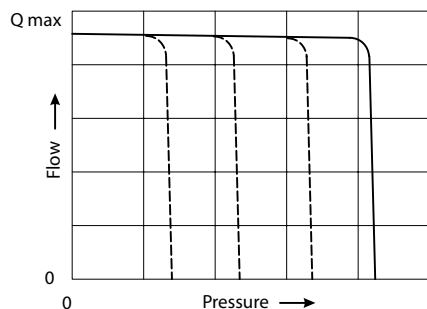

It is recommended that a relief valve be installed in the pump outlet for additional system protection.

Operation**Response/Recovery**

Pressure Compensated (PC) Control Response/Recovery Times* @80°C, 350 bar, 1500rpm		
Frame Size	Response (msec)	Recovery (msec)
130cc	150	270
145cc	150	270
193cc ¹	280	500
260cc	154	327

¹ Tested at 1800rpm

Values may vary depending on application conditions. For more information, please contact Danfoss Power Solutions.

Operation

NPSN (Pressure Compensated Control + Load Sensing Control)

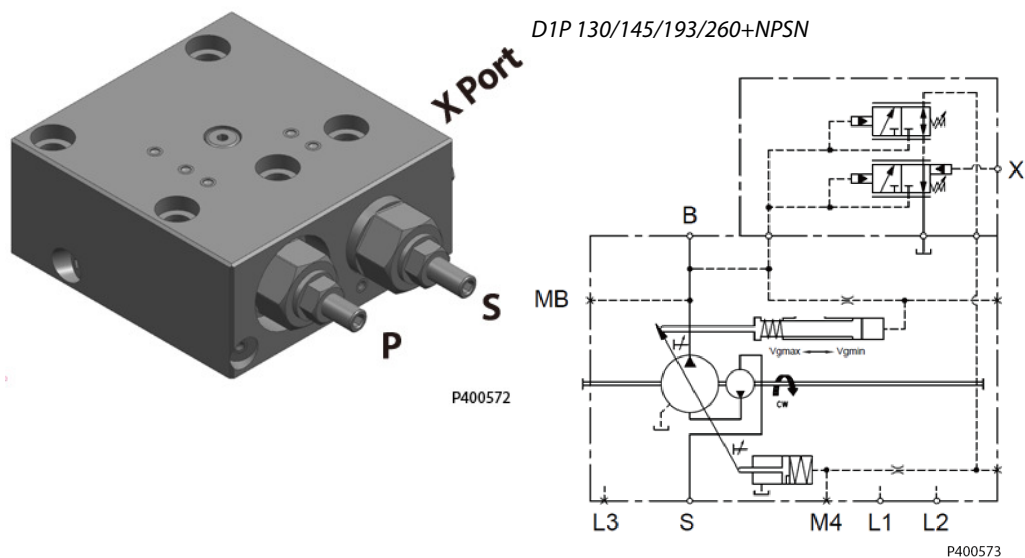

Pressure Compensated Control (P) Principle and Operation

Please refer to [NPNN \(Pressure Compensated Control\)](#) on page 9

Load Sensing Control (S) Principle

The S control design matches pump flow with system demand. The S control senses the flow demand of the system as a pressure drop across the external control valve (1).

As (1) opens and closes, the pressure difference (delta) across the valve changes. When opening, the delta decreases. When closing, the delta increases. The S control then increases or decreases pump flow to the system until the pressure delta becomes equal to the S setting as defined by the S adjusting screw and spring.

Load Sensing Control (S) Operation

Through internal porting, system pressure [upstream of (1)] is applied to the non-spring end of the S spool, and through hydraulic line connected at port X, load pressure [downstream of (1)] is applied to the spring end. This arrangement allows the S spool to act on the delta between system pressure and load pressure. The S spring sets the threshold of operation (S setting).

Because the swashplate is biased to maximum angle, the pump attempts to deliver full flow to the hydraulic system. When the flow being delivered exceeds demand, the pressure delta across the (1) is great enough to overcome spring force and shift the S spool porting system pressure to the servo piston. The pump de-strokes reducing flow until the delta across the (1) becomes equal to the S setting.

When flow being delivered is less than demand, the delta across the (1) drops below the S setting and the S spring shifts the spool connecting the servo piston to pump case. The pump strokes increasing flow until the delta across the (1) becomes equal to the S setting.

When the external control valve (1) is placed in neutral, it connects the LS signal line to drain. With no LS pressure acting on the non-spring end of the LS spool, the pump adjusts stroke to whatever position necessary to maintain system pressure at the LS setting. The pump is now in low pressure standby mode.

(1) is not in the scope of supply.

Operation

S characteristic

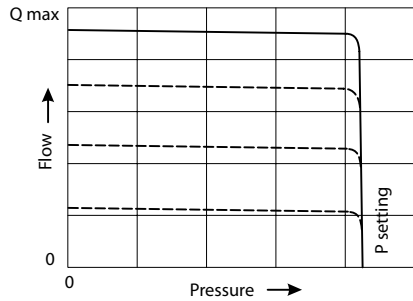

For additional system protection, install a relief valve in the pump outlet line.

NPSN Priority

The Pressure Compensated Control (P) has priority over the Load Sensing Control (S).

Response/Recovery

Load Sensing (LS) Response/Recovery Times @80°C, 1500rpm, LS Setting at 25 bar		
Frame Size	Response (msec)	Recovery (msec)
130cc	260	360
145cc	260	360
193cc ¹	233	264
260cc	309	327

¹ Tested with a LS setting of 20bar

Values may vary depending on application conditions. For more information, please contact Danfoss Power Solutions

Operation

NPNR (Pressure Compensated Control + Remote Pressure Compensated Control)

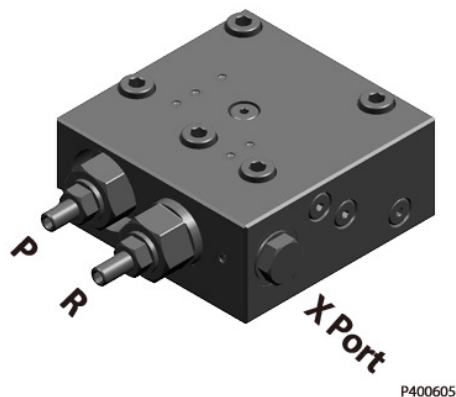

D1P 130/145/193/260+NPNR

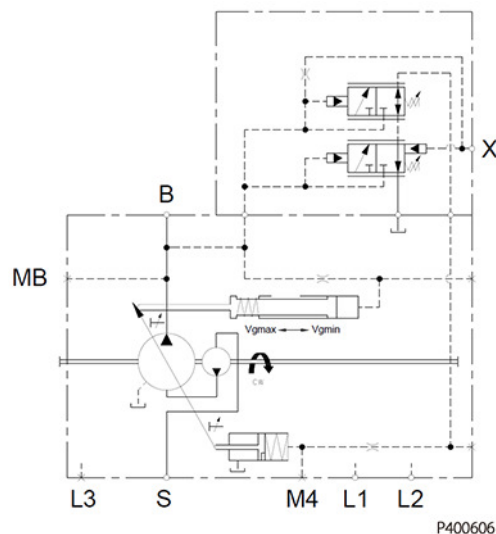

Pressure Compensated Control (P) Principle and Operation

Please refer to [NPNR \(Pressure Compensated Control\)](#) on page 9.

Remote Pressure Compensated Control (R) Principle

The remote PC control is a two-stage control that allows multiple PC settings. Remote PC controls are commonly used in applications requiring low and high pressure PC operation.

For this control, Danfoss recommends a load sense setting of 20bar.

Remote Pressure Compensated Control (R) Operation

The remote PC control uses a pilot line connected to an external hydraulic valve. The external valve changes pressure in the pilot line, causing the PC control to operate at a lower pressure. When the pilot line is vented to reservoir, the pump maintains pressure at the load sense setting. When pilot flow is blocked, the pump maintains pressure at the PC setting. An on-off solenoid valve can be used in the pilot line to create a low-pressure standby mode. A proportional solenoid valve, coupled with a microprocessor control, can produce an infinite range of operating pressures between the low pressure standby setting and the PC setting.

R characteristic

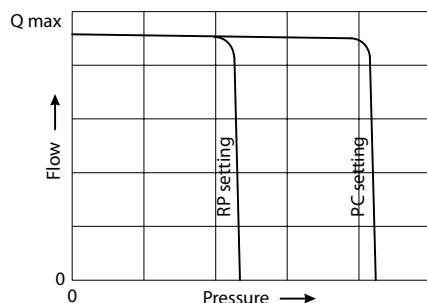

For additional system protection, install a relief valve in the pump outlet line.

Operation**NPNR Priority**

When the pump's X-port is vented to tank, or limited to some pressure setting via a remote valve, the remote pressure compensator function will control the maximum outlet pressure of the pump. If the pump's outlet pressure reaches the pressure setting of the pressure compensator (PC) function, the PC function will take priority and limit the pump's maximum pressure.

Operation

TPSN (Power Control + Pressure Compensated Control + Load Sensing Control)

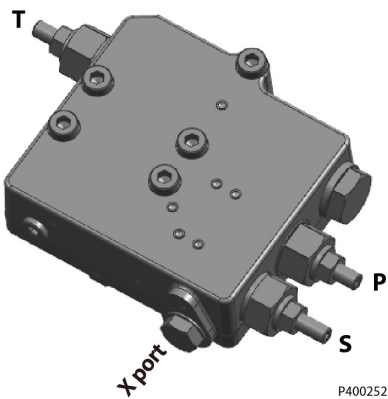

D1P 130/145+TPSN

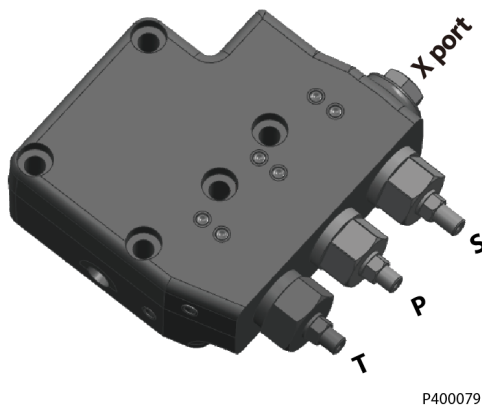
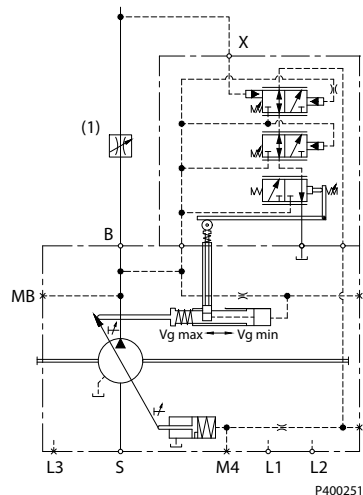

D1P 193/260+TPSN

*Control oil filter is optional

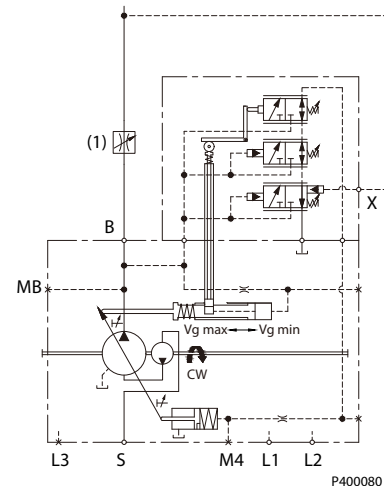

Power Control (T) Principle

The power control regulates the displacement of the pump depending on the working pressure so that a given drive power is not exceeded at constant drive speed, this function can prevent engine stall or protect electric generator.

$$P_B \cdot V_g = C$$

P_B = working pressure
 V_g = displacement
 C = constant

The precise control with a hyperbolic control characteristic, provides an optimum utilization of available power.

Operation

Power Control (T) Operation

The working pressure acts on a rack-pivot via a roller jack which produces a rotating torque, an externally adjustable spring force counteracts this which determines the power setting.

If the moment generated by working pressure exceeds the moment generated by spring force, the control valve is actuated by the rack-pivot, and pump reduces displacement. The lever length at the rack-pivot is shortened and the working pressure can increase at the same rate as the displacement decreases without the drive powers being exceeded.

$$(P_B \cdot V_g = C).$$

The hydraulic output power (characteristic T) is influenced by the efficiency of the pump.

T characteristic

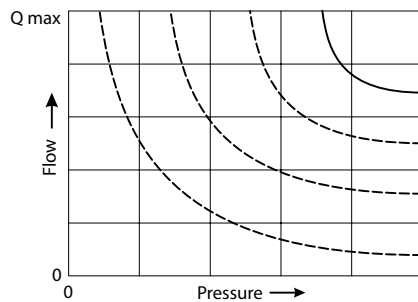

Pressure Compensated Control (P) Principle and Operation

Please refer to [NPNN \(Pressure Compensated Control\)](#) on page 9

Load Sensing Control (S) Principle and Operation

Please refer to [NPSN \(Pressure Compensated Control + Load Sensing Control\)](#) on page 11

TPSN Priority

The Pressure Compensated Control (P) has priority over the Power Control (T), Power Control has priority over Load Sensing Control (S).

Operation

NNES (Electric Displacement Control + Load Sensing Control)

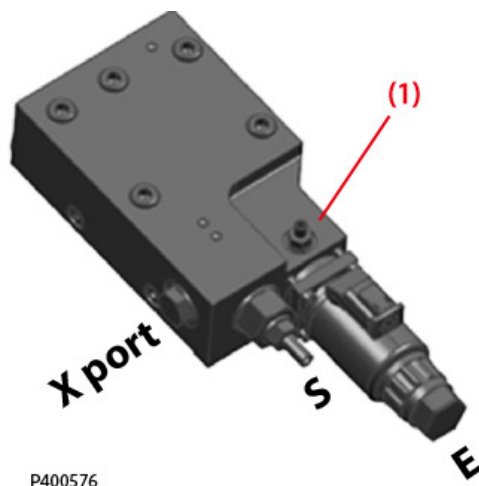

D1P 130/145/193/260 NNES

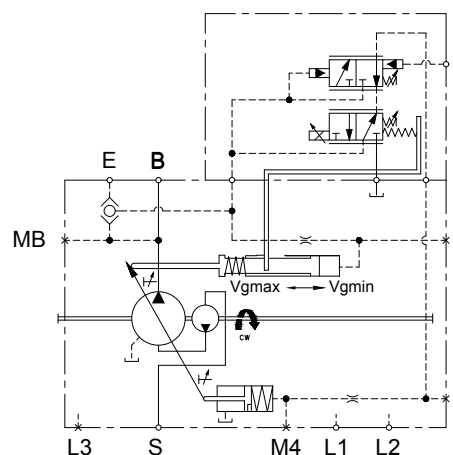

Warning

(1) Adjustment is not permissible

Electric Displacement Control (E) Principle

The electric displacement control uses an electric proportional solenoid valve to vary the pump's displacement from minimum displacement to maximum displacement or from maximum displacement to minimum displacement. The swashplate angle (pump displacement) is proportional to the electrical input signal (control current).

Electric Displacement Control (E) Operation

This control is current driven, requiring a Pulse Width Modulated (PWM) signal. Pulse width modulation allows more precise control of current to the solenoid. The PWM signal causes the solenoid pin to push against the E spool, which depressurizes the end of servo piston, the swashplate angle increases under the force of the bias piston

A washplate feedback link provides swashplate position force to the solenoid through the E spool's linear spring. The control reaches equilibrium when the position of the swashplate spring feedback force exactly balances the input command solenoid force from the operator. As working pressure changes with load, the control and servo/swashplate system work constantly to maintain the commanded position of the swashplate.

Electric Displacement Control (E) Operating Instruction

To make sure the electric displacement control works properly, a minimum control pressure of 30 bar [435 psi] is required. The required control pressure is taken either from the working pressure, or from the externally applied control pressure at the E port.

If you can't make sure that the working pressure is above 30 bar all the time, then a minimum of 30bar [435 psi] pressure supply at the E port is mandatory in order to control the displacement of the pump at all times. This pressure supply can be provided from different sources, such as an additional small gear or piston pump and a relief valve, or an accumulator.

If E port is not connected, remove the shuttle valve

Operation

Typical operating curve

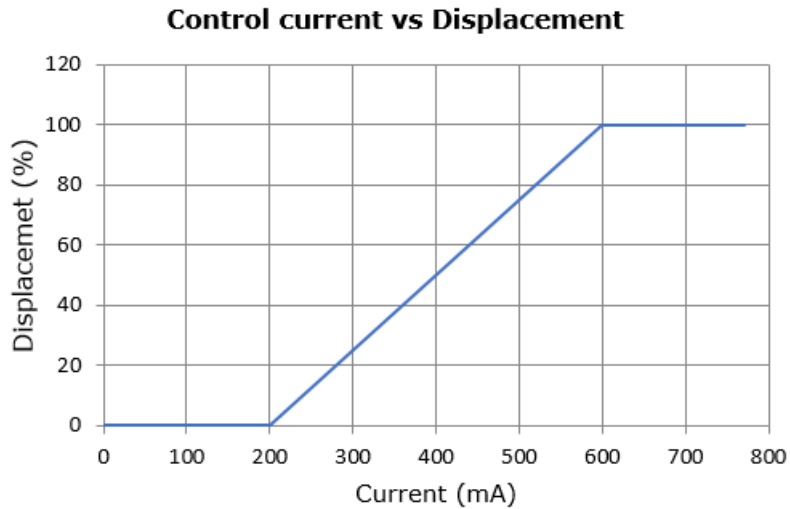

Hysteresis

EDC Hysteresis¹	
Input hysteresis	<4.5%
Output hysteresis @50% displacement	<4.0%

¹ Values may vary depending on application conditions. For more information, please contact Danfoss Power Solutions

Response/Recovery

Response/Recovery Times @ 1500rpm (50°C)¹		
Response 0%-100%	130cc (263 bar)	260 msec
	145cc (263 bar)	260 msec
	193cc (160 bar)	272 msec
	260cc (200 bar)	370 msec
Response 100%-0%	130cc (263 bar)	390 msec
	145cc (263 bar)	390 msec
	193cc (160 bar)	186 msec
	260cc (200 bar)	390 msec

MOR

Each Electric Displacement Control (EDC) is equipped with a Manual Over Ride (MOR) function for temporary actuation of the control to aid in diagnostics, even if insufficient or no current is supplied to the solenoid actuator. Initial activation of the MOR function will require a higher force to overcome the sticking effect between the pin and O-ring seal. Repeated activation of this functionality should provide better controllability.

Operation

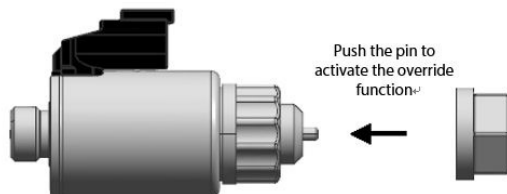

Warning

Do not actuate the MOR unless the machine is in a "SAFE" mode. Unintended MOR operation will cause the pump to go into stroke, use only for diagnosis purposes.

Solenoid Specification

Technical data - Solenoid

Voltage	24V (±20%)
Start current at Vg min.	200 mA
End Current at Vg max.	600 mA
Maximum current	770 mA
Coil Resistance @ 20 °C [70 °F]	22.7 Ω
PWM Range	70~200 Hz
PWM Frequency (preferred)*	100 Hz
IP Rating (IEC 60 529) + DIN 40 050, part 9	IP 67
IP Rating (IEC 60 529) + DIN 40 050, part 9 with mating connector	IP 69K

* PWM signal required for optimum control performance

Mating connector for Solenoid

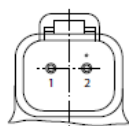

Description	Ordering Number	Quantity
Mating Connector	DEUTSCH DT06-2S	1
Wedge Lock	DEUTSCH W2S	1
Socket contact (16 and 18 AWG)	DEUTSCH 0462-201-16141	2
Danfoss mating connector kit	K29657	1

The mating connector is not included in the delivery contents, this can be delivered by Danfoss on request.

Compatible PLUS+1® controllers(see below):

MC012	L1301095
MC024	L1315302
MC038	11051653
MC050	L1301752
MC088	11006645

For further information: please visit: <http://www.danfoss.com/Products/MobileElectronics/index.htm>

Operation

Standard EDC Valve

The position of the connector can be changed by turning the solenoid body. Proceed as follows:

1. Loosen protection cap (1).
2. Loosen lock nut (2).
3. Turn the solenoid body (3) to the desired position.
4. Tighten the lock nut (2).
5. Tighten the protection cap (1).

Tightening Torque of lock nut: $5 \pm 1 \text{ N}\cdot\text{m}$ [44.25 \pm 8.85 lbf·in]

Standard EDC Valve

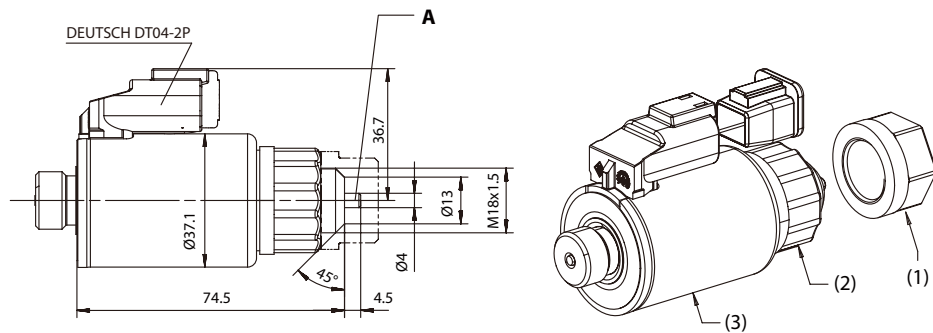

A - Actuation Forces	
Breakaway Force (First actuation)	45 N [10.12 lbf] max.
Repeat of Actuation	25 N [5.62 lbf] max.

NNES Priority

Both the Electric Displacement Control (EDC) and the Load Sensing Control (LS) are used to control the pump's displacement. The pump will output the smallest displacement when both control functions are given control instruct.

Operation

TPE2/TPE5 (Power Control + Pressure Compensated Control + Electric Displacement Control)

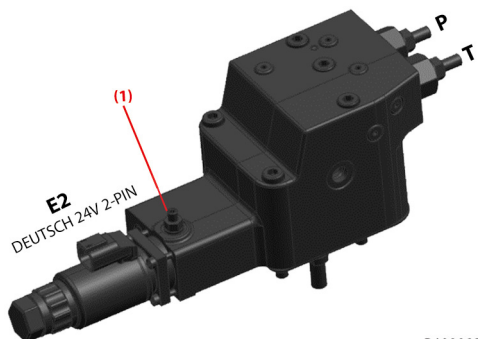

P400082

Warning

(1) Adjustment is not permissible

D1P 130/145+TPE5

D1P 193/260+TPE2

*Control oil filter is optional

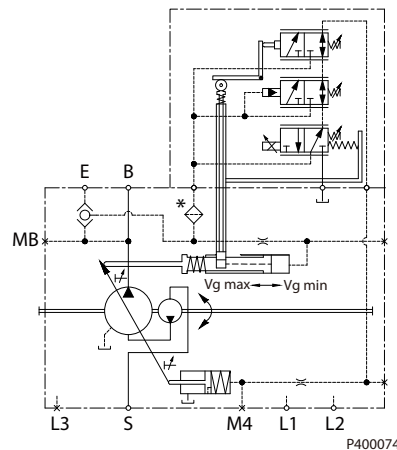

Power Control (T) Principle and Operation

Please refer to [TPSN \(Power Control + Pressure Compensated Control + Load Sensing Control\)](#) on page 15

Pressure Compensated Control (P) Principle and Operation

Please refer to [NPNN \(Pressure Compensated Control\)](#) on page 9

Electric Displacement Control (E2/E5) Principle and Operation

Please refer to [NNES \(Electric Displacement Control + Load Sensing Control\)](#) on page 17

TPE2/TPE5 Priority

The Pressure Compensated Control (P) has priority over the Power Control (T), and the Power Control (T) has priority over Electric Displacement Control (EDC).

Operation

NPE2/NPE0 (Pressure Compensated Control + Electric Displacement Control)

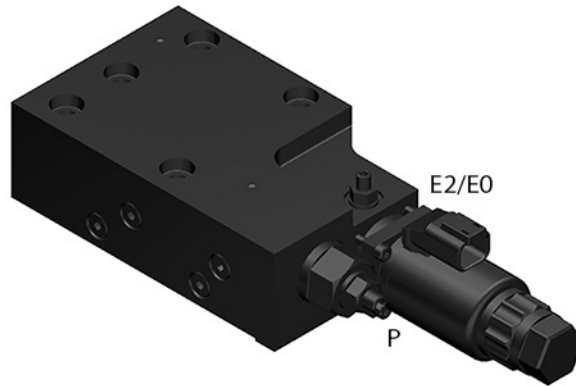

D1P 260 with NPE2 (left); D1P 260 with NPE0 (right)

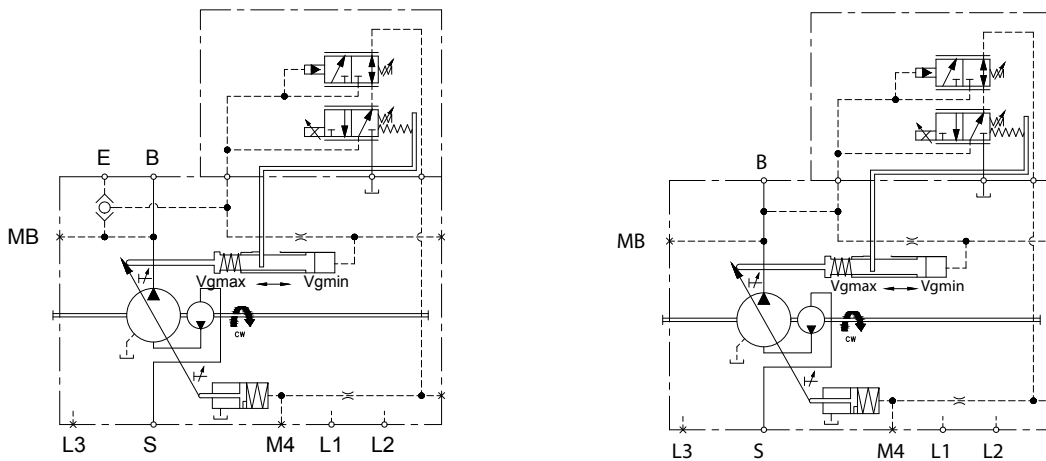

Pressure Compensated Control (P) Principle and Operation

Please refer to [NPNN \(Pressure Compensated Control\)](#) on page 9.

Electric Displacement Control (E2/E0) Principle and Operation

Please refer to [NNES \(Electric Displacement Control + Load Sensing Control\)](#) on page 17.

Shuttle Valve/Pilot Supply

Please refer to Electric Displacement Control (E) Operating Instruction section at [NNES \(Electric Displacement Control + Load Sensing Control\)](#) on page 17.

To determine if an external control pilot supply is needed, please consult your Danfoss Power Solutions representative.

D1P pumps configured with an NPE2 control will come with a shuttle valve installed at the E port. D1P pumps with an NPE0 control will not include the shuttle valve.

Operating parameters

D1P pressure overview

Maximum working pressure	The highest recommended outlet (application). Operating at or below this pressure should yield satisfactory product life. For all applications, the load should move below this pressure. This corresponds to the maximum allowable pressure compensated control setting.
Maximum (peak) pressure	The highest intermittent ($t < 1s$) outlet pressure allowed. Maximum machine load should never exceed this pressure, and pressure overshoots should not exceed this pressure.
Inlet pressure	The absolute pressure in the pump suction port, it is related to pump speed. Make sure it is in the allowable range, see D1 pump specifications on page 25.
Case pressure	The case pressure at the ports L1 and L2 may be a maximum of 1.2 bar [17.4 psi] higher than the inlet pressure at the port S but not higher than 2 bar. Size drain plumbing accordingly and connect it to tank directly. The housing must always be filled with hydraulic fluid.

D1P speed overview

Rated speed	The fastest recommended operating speed at full displacement and at least 0.6 bar [8.7 psi] abs with charge pump (0.8 bar [11.6 psi] abs without charge pump) inlet pressure. Operating at or below this speed should yield satisfactory product life.
Maximum speed	The highest recommended operating speed at full power conditions. Operating at or beyond maximum speed requires positive inlet pressure and/or a reduction of pump outlet flow. Refer to Inlet pressure vs. speed on page 23, chart below.

Inlet pressure vs. speed

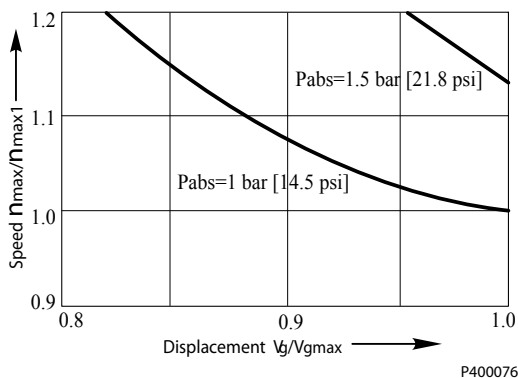

Minimum speed	The lowest operating speed allowed. Operating below this speed will not yield satisfactory performance.
----------------------	---

Caution! Threat to pump life!

Working outside of the pump's operating parameters may result in shortened life expectancy of the pump.

Always work within the operating conditions of the pump application.

With accurate duty cycle information, your Danfoss Power Solutions representative can assist you in calculating expected pump life.

D1P fluid overview

Ratings and performance data for D1 pumps are based on operating with premium hydraulic fluids containing oxidation, rust, and foam inhibitors. These include premium turbine oils, API CD engine oils

Operating parameters

per SAE J183, M2C33F or G automatic transmission fluids (ATF), Dexron II (ATF) meeting Allison C-3 or Caterpillar TO-2 requirements, and certain specialty agricultural tractor fluids. For more information on hydraulic fluid selection, see Danfoss Power Solutions publications **520L0463** *Hydraulic Fluids and Lubricants*, Technical Information, and **520L0465** *Experience with Biodegradable Hydraulic Fluids*, Technical Information.

D1P viscosity

Minimum Viscosity This should only occur during brief occasions of maximum ambient temperature and severe duty cycle operation.

Maximum Viscosity This should only occur at cold start. Pump performance will be reduced. Limit speeds until the system warms up.

Maintain fluid viscosity within the recommended range for maximum efficiency and pump life.

D1P temperature overview

Minimum Temperature Relates to the physical properties of the component materials. Cold oil will not affect the durability of the pump components. However, it may affect the ability of the pump to provide flow and transmit power

Maximum Temperature Relates to material properties. Don't exceed it. Measure maximum temperature at the hottest point in the system. This is usually the case drain.

D1P fluid velocity

Choose piping sizes and configurations sufficient to maintain optimum fluid velocity, and minimize pressure drops. This reduces noise, pressure drops, overheating and maximizes system life and performance.

Recommended fluid velocities

System lines	6 to 9 m/sec
Suction line	1 to 2 m/sec
Case drain	3 to 5 m/sec

Typical guidelines; obey all pressure ratings.

Velocity equations

SI units

Q = flow (l/min)

A = area (mm²)

Velocity = (16.67•Q)/A (m/sec)

Technical specifications

D1 pump specifications

(Theoretical values, without efficiency and tolerances; values rounded)

Features		Unit	65	130		145		193	260
			W/O Charge Pump	W/O Charge Pump	W/ Charge Pump	W/O Charge Pump	W/ Charge Pump	W/Charge Pump	W/Charge Pump
Displacement	Maximum	cm ³ [in ³]	65 [3.84]	130 [7.93]	130 [7.93]	145 [8.85]	145 [8.85]	193 [11.78]	260 [15.87]
	Minimum		0	0	0	0	0	0	0
Available Rotation		CCW [L]	●	●	●	●	●	●	●
		CW [R]		●	●	●	●	●	●
Input Speed	Min.	rpm	500	500	500	500	500	500	500
	Rated at max. displacement (Vg max.)		2550	2200 ¹	2500 ²	2200 ²	2500 ³	2500 ³	2300 ³
	Maximum at Vg < Vg max. ³		3000	2500	2500	2200	2500	2500	2300
Flow at max. speed & displacement (n max. & Vg max.)		l/min [US gal/min]	165 [44]	286 [76]	325 [86]	319 [84]	363 [96]	483 [128]	598 [158]
System (Working) Pressure ⁴	Max. Working Pressure	bar [psi]	350 [5076]						
	Max. Pressure		400 [5802]						
Inlet Pressure (Absolute)	Minimum	bar [psi]	0.8 [11.6]	0.8 [11.6]	0.6 [8.7]	0.8 [11.6]	0.6 [8.7]	0.6 [8.7]	0.6 [8.7]
	Maximum		30 [435]	30 [435] ⁵	2 [29]	30 [435]	2 [29]	2 [29]	2 [29]
Case Pressure (Absolute)	Maximum above inlet	bar [psi]	1.2 [17.4]						
	Maximum		2 [29]						
Filling Capacity		L [US gal]	2.1 [0.55]	2.9 [0.77]		2.9 [0.77]		3.8 [1]	4.6 [1.3]
Torque at Vg max. & Δp = 350 bar		N•m [lbf•in]	362 [3204]	724 [6408]		808 [7151]		1075 [9515]	1448 [12816]
Power at Q max. (max. flow) & Δp = 350 bar		kW [hp]	97 [130]	159 [213]	190 [255]	186 [249]	211 [283]	281 [377]	349 [468]
Mass Moment of Inertia of internal rotating components		kg•m ² [slug•ft ²]	0.0151 [0.0111]	0.0299 [0.0221]	0.0306 [0.0226]	0.0299 [0.0221]	0.0306 [0.0226]	0.0576 [0.0426]	0.2080 [0.1537]
Mass		kg [lb]	47 [104]	68 [150]	74 [163]	68 [150]	74 [163]	106 [234]	141 [311]
External Shaft Loads	External Moment M _e	N•m [lbf•in]	250 [2216]	476 [4213]		476 [4213]		822 [7275]	1081 [9568]
Mounting Flange Load Moments	Vibratory (continuous)	N•m [lbf•in]	2360 [20888]	4553 [40297]		4553 [40297]		6286 [55636]	8477 [75027]
	Shock (maximum)		4506 [39881]	8692 [76930]		8692 [76930]		13782 [121980]	16338 [144603]

¹ The values apply at absolute pressure (Pabs) of at least 0.8 bar [11.6psi] at the suction port S and mineral hydraulic fluid.

² The values apply at absolute pressure (Pabs) of at least 0.6 bar [8.7psi] at the suction port S and mineral hydraulic fluid.

³ The values apply at Vg ≤ Vg max or in case of an increase in the inlet pressure (Pabs) at the suction port S. Please refer to *Inlet Pressure vs Speed* Graph at [D1P speed overview](#) on page 23

⁴ Applied pressures above maximum working pressure requires Danfoss application approval. Maximum (peak) pressure is the highest intermittent (τ<1s) outlet pressure allowed.

⁵ If the application requires the higher inlet pressure than 5 bar [72.5psi] (up to 30 bar [435psi]), please contact.Danfoss Power Solutions.

Counterclockwise (CCW) & Clockwise (CW) directions as viewed from the shaft end of the pump.

Technical specifications

Exceeding the permissible values could cause a loss of function, reduced life or the destruction of the pump.
Do not exceed the values shown in the table above.

D1P fluid specifications

Features		Units	Value
Viscosity	Intermittent ¹⁾	mm ² /sec [SUS]	5 [42]
	Minimum		7 [49]
	Recommended range		16 - 36 [81 - 168]
	Maximum (cold start) ²⁾		1600 [xxxxx]
Temperature range	Minimum (cold start) ²⁾	°C [°F]	-40 [-40 °F]
	Maximum intermittent ¹⁾		115 [239 °F] ³⁾
Filtration (minimum) Cleanliness per ISO 4406	Temperature Range: -40 - 90 °C [-40 - 194°F]		20/18/15
	Temperature Range: 90 - 115 °C [194 - 239°F]		19/17/14

¹⁾ Intermittent = Short term t < 3min per incident.

²⁾ Cold start = Short term t < 3min, p ≤ 30 bar [435 psi], n ≤ 1000 min⁻¹(rpm) , please contact Danfoss Power Solutions especially when the temperature is below -25 °C [-13 °F].

³⁾ Must not be exceeded locally either (e.g. in the bearing area) . The temperature in the bearing area is (depending on pressure and speed) up to 5 °C [41 °F] higher than the average case drain temperature.

Fluid and filter maintenance

Recommendations of fluid and filter maintenance

To ensure optimum life of D1 pumps, perform regular maintenance of the fluid and filter. Contaminated fluid is the main cause of unit failure. Take care to maintain fluid cleanliness when servicing.

Check the reservoir daily for proper fluid level, the presence of water, and rancid fluid odor. Water in the fluid may be noted by a cloudy or milky appearance or free water in the bottom of the reservoir. Rancid odor indicates the fluid has been exposed to excessive heat. Change the fluid immediately if these conditions occur. Correct the problem immediately.

Change the fluid and filter per the vehicle / machine manufacturer's recommendations or at these intervals: Change the fluid more frequently if it becomes contaminated with foreign matter (dirt, water, grease, etc.) or if the fluid is subjected to temperature levels greater than the recommended maximum.

Fluid and filter change interval

Reservoir type	Maximum change interval
Sealed	2000 hours
Breather	500 hours

[Dispose of used hydraulic fluid properly. Never reuse hydraulic fluid.](#)

Change filters whenever the fluid is changed or when the filter indicator shows that it is necessary to change the filter. Replace all fluid lost during filter change.

Pressure measurements

Port Locations and Gauge Installation (65)

The following table and drawing show the port locations and gauge sizes needed. When testing system pressures, calibrate pressure gauges frequently to ensure accuracy. Use snubbers to protect gauges.

Port	Purpose	Port size	Wrench size	Range of gauge
L1, L2, L3	Case drain	M18x1.5	8mm	0-60 bar [0-870.23 psi]
M _B	Outlet pressure gauge port	M12x1.5	6mm	0-600 bar [0-8702.26 psi]
M ₄	Servo piston chamber pressure gauge port	M12x1.5	6mm	0-600 bar [0-8702.26 psi]
M ₅	Suction pressure gauge port	M12x1.5	6mm	0-600 bar [0-8702.26 psi]

D1P 65 port locations with TPSN control

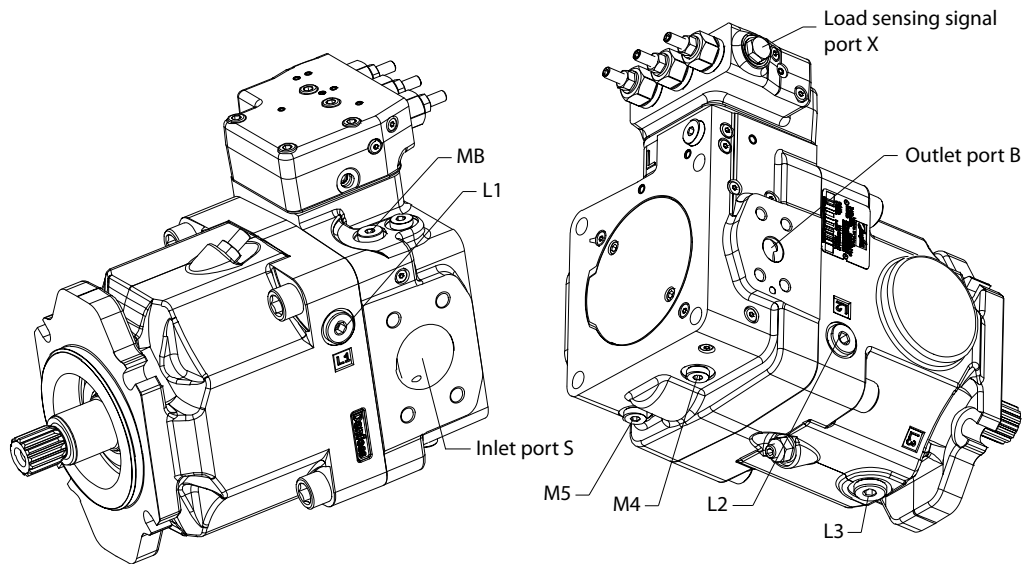

Pressure measurements

Port Locations and Gauge Installation (130/145)

The following table and drawing show the port locations and gauge sizes needed. When testing system pressures, calibrate pressure gauges frequently to ensure accuracy. Use snubbers to protect gauges.

Port	Purpose	Port size	Wrench size	Range of gauge
L1, L2, L3	Case drain	M26x1.5	12 mm	0-60 bar [0-870.23 psi]
M_B	Outlet	M12x1.5	6 mm	0-600 bar [0-8702.26 psi]
M₄	Servo piston chamber	M12x1.5	6 mm	0-600 bar [0-8702.26 psi]

130/145 Port locations, Control type: TPSN

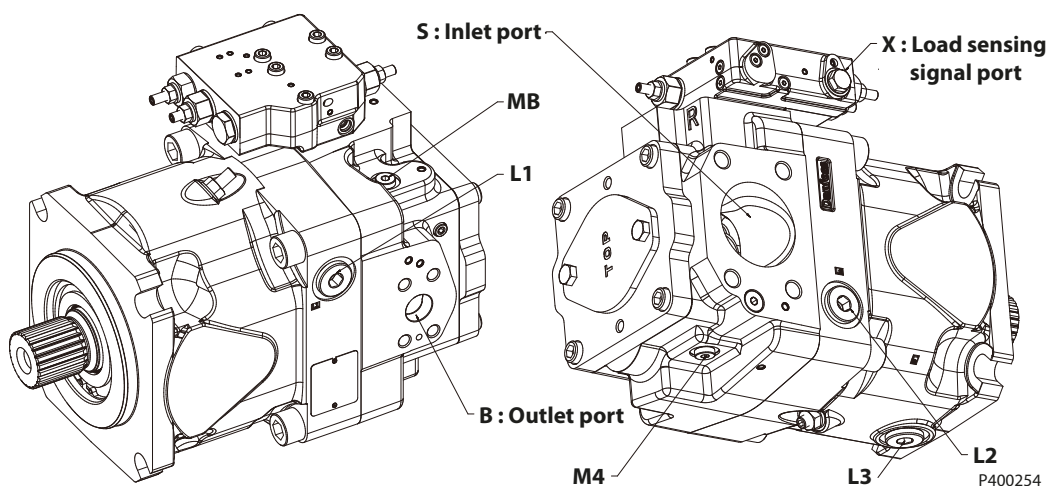

Pressure measurements

Port Locations and Gauge Instalation (193/260)

Port	Purpose	Port size	Wrench size	Range of gauge
L1, L2, L3	Case drain	M33x2	17 mm	0-60 bar [0-870.23 psi]
M_B	Outlet	M12x1.5	6 mm	0-600 bar [0-870.23 psi]
M₄	Servo piston chamber	M12x1.5	6 mm	0-600 bar [0-870.23 psi]

193/260 Port location, Control type: TPE2

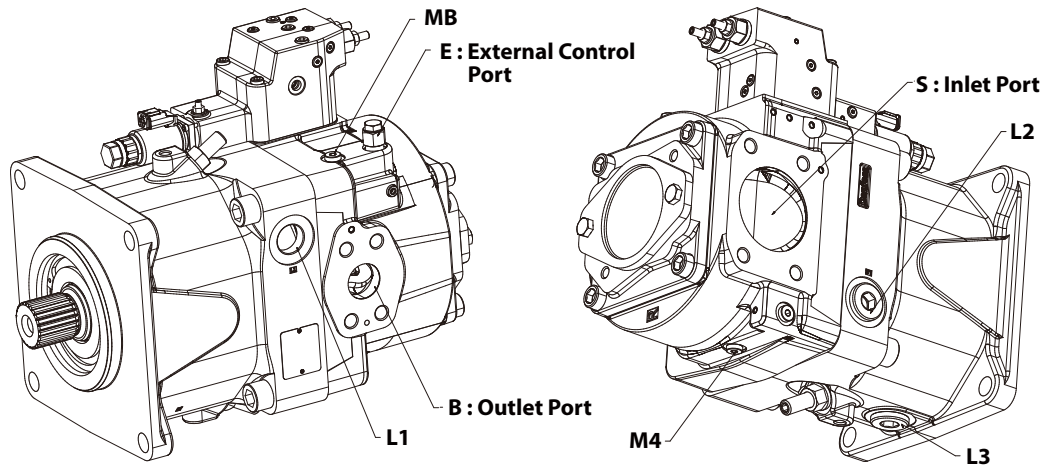

193/260 Port location, Control type: TPSN

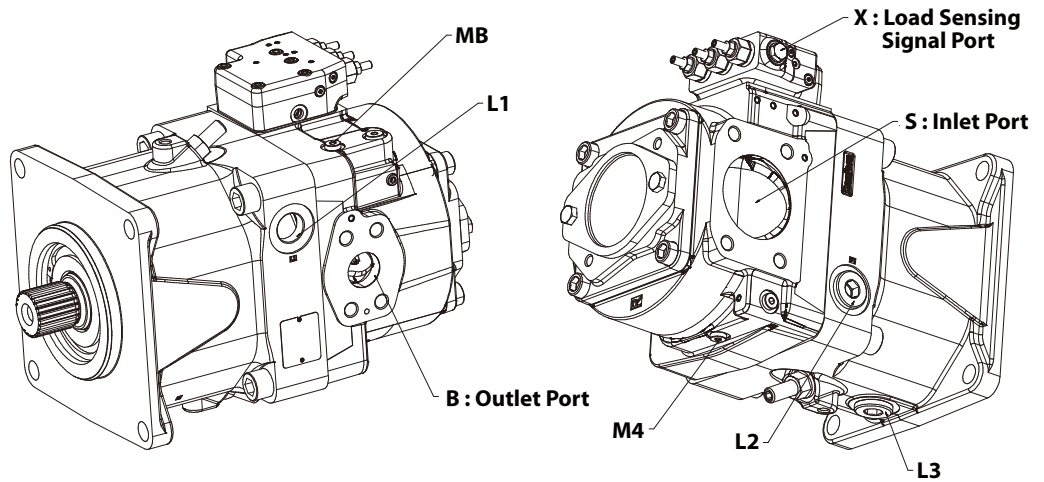

P400092

Initial start-up procedures

General

Follow this procedure when starting-up a new D1 installation or when restarting an installation in which the pump has been removed.

Prior to installing the pump, inspect for damage incurred during shipping. Make sure all system components (reservoir, hoses, valves, fittings, heat exchanger, etc.) are clean prior to filling with fluid.

Start-up Procedure

1. Connect the pump to the prime mover.

Ensure that the pump shaft is properly aligned with the shaft of the prime mover. Alignment should be within 0.25 mm and the angle must not exceed 0.2°.

 **Caution**

Incorrect shaft alignment may result in damage to drive shaft, bearings, or seal which can cause external oil leakage.

2. Fill the reservoir with a recommended hydraulic fluid.
Always filter fluid through a 10 micron filter while pouring into the reservoir. Never reuse hydraulic fluid.
3. Fill the main pump housing with clean hydraulic fluid. Pour filtered oil directly into the upper most case drain port.
4. Fill the inlet line leading from the pump to the reservoir. Check the inlet line for properly tightened fittings and be certain it is free of restrictions and air leaks.
5. To ensure the pump stays filled with oil, install the case drain line in the upper most case drain port.
6. Install a gauge at port **MB** to monitor system pressure during start up.

[Follow recommendations in the vehicle / machine operator's manual for prime mover start up procedures.](#)

7. Switch system to free circulation or to lowest pressure, jog the prime mover or run at the lowest possible speed until pump and all pipes are filled and free from air bubbles. Raise pressure setting only when all air is removed.
Let the pump work at reduced pressure for 5 - 10 min, check if all pipes and connections are leak-free and tight.
8. Check the suction pressure at port **S** of the axial piston pump at nominal speed and maximum flow, make sure it is in allowable range.
9. Check the case drain pressure at the connected port **L1** or **L2** at maximum pressure, make sure it is in allowable range.
10. Shut down the prime mover and remove the pressure gauge. Replace plug at port **MB**.
11. Check the fluid level in the reservoir; add clean filtered fluid if necessary.

The pump is now ready for operation.

Troubleshooting

Excessive Noise and /or Vibration

Item	Description	Action
Check fluid level in reservoir.	Insufficient hydraulic fluid causes cavitation.	Fill the reservoir to proper level.
Check for air in system.	Air in system causes noisy, erratic control.	Purge air and tighten fittings. Check inlet for leaks.
Check pump inlet pressure / vacuum.	Improper inlet conditions cause erratic behavior and low output flow.	Correct pump inlet pressure / vacuum conditions.
Inspect shaft couplings.	A loose or incorrect shaft coupling causes excessive noise and / or vibration.	Repair or replace coupling and ensure that correct coupling is used.
Check shaft alignment.	Misaligned shafts create excessive noise and / or vibration.	Correct shaft misalignment.
Hydraulic fluid viscosity above acceptable limits.	Hydraulic fluid viscosity above acceptable limits or low fluid temperature will not allow the pump to fill or control to operate properly.	Allow system to warm up before operating, or use fluid with the appropriate viscosity grade for expected operating temperatures.

Low Pump Output Flow

Item	Description	Action
Check fluid level in reservoir.	Insufficient hydraulic fluid will limit output flow and cause internal damage to pump.	Fill the reservoir to proper level.
Hydraulic fluid viscosity above acceptable limits.	Fluid viscosity above acceptable limits or low fluid temperature will not allow the pump to fill or control to operate properly.	Allow system to warm up before operating, or use fluid with the appropriate viscosity grade for expected operating temperatures.
Check external system relief valve setting.	External relief valve set below PC setting causes low output flow.	Adjust external relief valve following manufacturer's recommendation. External relief valve setting must be above PC setting to operate properly.
Check pressure compensate (PC), load sensing (LS) and power (T) control setting.	Low PC setting prevents the pump from achieving full stroke. Low LS setting limits output flow. Low T setting limits output flow.	Contact Danfoss Service.
Check LS control signal pressures.	Incorrect LS signal will not allow pump to operate correctly.	Inspect system to ensure that proper LS signal transmit to pump.
Check Pilot pressure for hydraulics displacement control and input current for electric displacement control.	Incorrect input signal causes low output flow.	Adjust input hydraulic or electric signal to right value.
Check pump inlet pressure / vacuum.	High inlet vacuum causes low output flow.	Correct inlet pressure conditions.
Check input speed.	Low input speeds decrease flow.	Adjust input speed.
Check pump rotation.	Incorrect rotational configuration causes low flow.	Use pump with appropriate rotational configuration.

No or Low System Pressure

Item	Description	Action
Check pressure compensate (PC) and power (T) control setting.	Low PC and T setting leads to low system pressure.	Contact Danfoss Service.
Check external relief valve.	External relief valve setting below PC setting.	Adjust external relief valve according to manufacturer's recommendations. External relief valve must be set above PC setting to operate properly.

Troubleshooting

Item	Description	Action
Check pilot pressure or control pressure.	Insufficient pilot pressure or control pressure.	Increase them to appropriate value.
Internal system leaks.	Worn internal parts don't allow the pump to operate properly.	Refer to Authorized Service Center for required repair.

Actuator Response is Sluggish

Item	Description	Action
Check external system relief valve setting.	Low external relief valve setting slows down system.	Adjust external relief valve setting following manufacturer's recommendations. External relief setting must be above PC setting to operate properly.
Check pressure compensate (PC), load sensing (LS) and power (T) control setting.	Low PC setting prevents the pump from achieving full stroke. Low LS setting limits output flow. Low T setting limits output Torque.	Contact Danfoss Service.
Check LS control signal pressures.	Incorrect LS signal will not allow pump to operate correctly.	Inspect system to ensure that proper LS signal transmit to pump.
Check Pilot pressure for hydraulics displacement control and input current for electric displacement control.	Incorrect input signal causes low output flow.	Adjust input hydraulic or electric signal to right value.
Internal system leaks.	Worn internal parts don't allow the pump to operate properly.	Refer to Authorized Service Center for required repair.
Hydraulic fluid viscosity above acceptable limits.	Hydraulic fluid viscosity above acceptable limits or low fluid temperature will not allow the pump to fill or control to operate properly.	Allow system to warm up before operation or sue fluid with the appropriate viscosity grade for expected operating temperatures.
Check external system valving.	Malfunctioning valving may not allow system to respond properly.	Repair or replace system valving as required.
Check pump case pressure.	High case pressure causes the system to be sluggish.	Correct case drain line restrictions.
Check pump inlet pressure / vacuum.	High inlet vacuum causes low output flow.	Correct inlet pressure conditions.

Pressure or Flow Instability

Item	Description	Action
Check for air in system.	Air in system causes erratic operation.	Activate PC allowing system to bleed air. Check inlet line for leaks and eliminate source of air ingress.
Check LS setting.	Low LS setting may cause instability.	Contact Danfoss Service.
Check LS signal line.	Blocked LS signal line interferes with proper LS operation.	Remove blockage.
Check external relief valve and PC setting.	Insufficient pressure differential between PC setting and external relief valve.	Adjust external relief valve or PC control settings to appropriate level. Relief valve setting must be above PC setting to operate properly.
Check external relief valve.	Chattering external relief valve may cause unstable feedback to pump control.	Adjust or replace relief valve.

Troubleshooting

System Operating Hot

Item	Description	Action
Check fluid level in reservoir.	Insufficient volume of hydraulic fluid will not meet cooling demands of system.	Fill reservoir to proper level. Verify proper size of reservoir.
Inspect heat exchanger. Check air flow and input air temperature for the heat exchanger.	Insufficient air flow, high input air temperature, or undersized heat exchanger will not meet cooling demands of the system.	Clean, repair, or replace heat exchanger as required. Verify proper size of heat exchanger.
Check external system relief valve setting.	Fluid passing through relief valve adds heat to system.	Adjust external system relief valve setting following manufacturer's recommendations. External relief valve setting must be above PC setting for proper operation.
Check pump inlet pressure / vacuum.	High inlet vacuum adds heat to system.	Correct inlet pressure / vacuum conditions.

High Inlet Vacuum

Item	Description	Action
Check fluid temperature.	Low temperature increases viscosity. High fluid viscosity causes high inlet vacuum.	Allow system to warm up before operating.
Inspect inlet screen.	Blocked or restricted inlet screen causes high inlet vacuum.	Clean screen / remove blockage.
Check inlet piping.	Too many fittings, bends, or long piping causes high inlet vacuum.	Eliminate fittings to make path more direct.
Hydraulic fluid viscosity above acceptable limits.	High fluid viscosity causes high inlet vacuum.	Select fluid with appropriate viscosity for expected operating temperature.

 **Caution**

High inlet vacuum causes cavitation which can damage internal pump components.

Adjustments

Calculate Power Control Start Point Pressure and Corresponding Flow in Advance

If Power/Torque control is used:

1. Calculate the power control start point pressure according to the formula:

$$\text{Power} = P \cdot n \cdot V_g \cdot \frac{10^{-3}}{600 \cdot \eta}$$

P Power control start point pressure [bar]

n Pump input speed [rpm]

V_g Pump theoretical displacement [cc]

η Total efficiency, set at 91.2%

The start point pressure is the point in the Pressure vs Flow performance curve in which the Torque control becomes active. The PC setting must be higher than this value, otherwise the PC function will take priority before the MTC function becomes active. If the desired power setting is 90kW, the pump input speed is 1500 rpm and the pump's theoretical displacement is 193cc, then solve for start point Pressure:

$$90 = P \cdot 1500 \cdot 193 \cdot \frac{10^{-3}}{600 \cdot (.912)}$$

Start point Pressure is calculated to be 170bar.

2. Use the average value between the start point Pressure and the Pressure Compensated Control setting as a reference value; this value must be inside the "TC active" region. For example: Power control start point Pressure is 170 bar, and the Pressure compensated control setting desired is 320 bar. Use the average value $(170+320)/2=245$ bar.

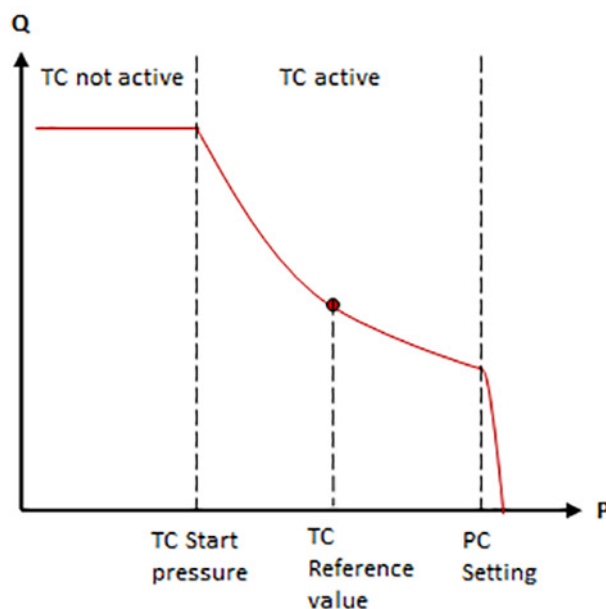

3. Calculate corresponding flow by using the following formula:

$$\text{Power [kW]} = \frac{P \cdot Q}{600 \cdot \eta}$$

$$90 = \frac{245 \cdot Q}{600 \cdot (.912)}$$

$$Q=201 \text{ l/min}$$

Adjustments

Adjustments

Control		65	130/145	193	260
NPNN	If the desired power setting is 90kW, the pump input speed PC [bar per turn]	N/A	163.2	163.2	163.2
NPSN & NPNR	PC [bar per turn]	N/A	163.2	163.2	163.2
	LS [bar per turn]	N/A	26.4	26.4	26.4
TPSN	PC [bar per turn]	163.2	271	163.2	163.2
	LS [bar per turn]	26.4	50	26.4	26.4
	MTC [kW per turn]@1500rpm	31	39	73.5	99
NNES	LS [bar per turn]	N/A	26.4	26.4	26.4
	EDC [mA offset per turn]	N/A	263	263	263
TPE5	PC [bar per turn]	N/A	163.2	N/A	N/A
	MTC [kW per turn]@1500rpm	N/A	50.8	N/A	N/A
	EDC [mA offset per turn]	N/A	263	N/A	N/A
TPE2	PC [bar per turn]	N/A	N/A	163.2	163.2
	MTC [kW per turn]@1500rpm	N/A	N/A	73.5	99
	EDC [mA offset per turn]	N/A	N/A	263	263

Electric Displacement Control Adjustment

1. Install a pressure gauge in port **MB** to measure outlet pressure. Install a flow meter in outlet line to measure pump flow.

⚠ Warning

Escaping hydraulic fluid under pressure can have sufficient force to penetrate your skin causing serious injury and/or infection. Relieve pressure in the system before removing hoses, fittings, gauges, or components.

Unintended movement of the machine or mechanism may cause injury to the technician or bystanders. To protect against unintended movement, secure the machine or disable / disconnect the mechanism while servicing.

⚠ Caution

Contamination can damage internal components and void the manufacturer's warranty. Take precautions to ensure system cleanliness when removing and reinstalling system lines.

2. Start the prime mover and input 700 mA to electric displacement control solenoid valve, then allow fluid to reach normal operating temperature. The pump must be at full displacement at this point. Danfoss recommends a prime mover speed of 1500rpm (unless specified otherwise).

The testing setup must be plumbed in a way so the EDC function works properly. Please refer to [Electric Displacement Control \(E\) Operating Instruction](#).

3. Totally lock the LS control (if used) to avoid interference with EDC adjustment.
 - a) Loosen the LS control lock nut and turn the LS control adjusting screw clockwise all the way to the end, while holding the LS control adjusting screw.
 - b) Torque the control lock nut to 21.6~24.6 N·m [191-218 lbf·in].

Adjustments

4. Load the pump's outlet pressure to 50 bar and input 400mA to electric displacement control, then loosen the electric displacement control lock nut and turn its adjusting screw until the pump displacement achieves (see [Displacement](#) table below), which can be calculated by monitoring pump outlet flow and pump speed. Clockwise turning adjusting screw decrease pump displacement, counterclockwise turning increase pump displacement. The displacement - current curve will offset (see [Adjustments](#) table) per turn.
5. While holding the position of the electric displacement control adjusting screw, torque the lock nut to 9.5 N•m [84 lbf•in].
6. Test another current value. Input 500 mA to electric displacement control, check if the displacement is within the range specified in the below table at this moment. If it is, the electric displacement control adjustment is complete, if it is not, please re-adjust.
7. Stop the prime mover, remove the pressure gauge and flow meter, and return the system to its normal operating configuration.

Displacement

Input Current	Size 130	Size 145	Size 193	Size 260
400mA±8 mA	67.5cc±5cc	67.5cc±5cc	92.5 cc±5cc	140.5 cc±5cc
500mA±8 mA	101cc±5cc	101cc±5cc	115.5 cc±5cc	172.5 cc±5cc

Adjustments

Pressure Compensated Control Adjustment

1. Install a pressure gauge in port **MB** to measure outlet pressure.
2. Ensure the pump is operating at maximum displacement. If the control has Electric Displacement Control, input 700mA to obtain maximum displacement.
3. Load the pump outlet pressure to at least 30 bar higher than the expected pressure compensated control setting. This may be achieved by operating a hydraulic function to its full extension, putting the pump in a dead-head condition.
4. Loosen the Pressure compensated control lock nut and turn the Pressure compensated control adjusting screw until the desired setting is indicated on the pressure gauge at port **MB**. Clockwise rotation increases pressure, counterclockwise rotation decreases; approximate gain per turn (see [Adjustments](#) table). Once the PC adjustment is complete, hold the position of the adjustment screw and torque the PC control lock nut to 21.6-24.6 N·m [lbf·in].
5. Stop the prime mover, remove the pressure gauge, and return the system to its normal operating configuration.

If the pressure does not increase, an external system relief valve may require adjustment. External system relief valve must be set above the Pressure compensated control setting for proper operation.

Power Control Adjustment

1. Install a pressure gauge in port **MB** to measure outlet pressure. Install a flow meter in outlet line to measure pump flow.
2. Start the prime mover and make sure the pump is operating at maximum displacement. If the control has Electric Displacement Control, input 700mA to obtain maximum displacement. By doing this, the functions will not interfere with each other, if maximum displacement is commanded by the EDC at all times, the MTC function will take priority once the start point pressure is reached.
3. Load the pump outlet pressure to the reference pressure value previously obtained in the calculation, loosen the power control lock nut and turn the power control adjusting screw and monitor the flow meter, when the flow meter shows the flow corresponding to the previous calculation, stop turning, while holding the position of power control adjusting screw, torque the power control lock nut to 21.6~24.6 N·m [191-218 lbf·in]. Clockwise rotation increases power, counterclockwise rotation decreases, approximate gain per turn (See [Adjustments](#) table.)
4. Stop the prime mover, remove the pressure gauge and flow meter, and return the system to its normal operating configuration.

Load Sensing Control Adjustment

1. Install a pressure gauge in port **MB** to measure outlet pressure, Tee-in a pressure gauge to the LS signal line (port **X**) to measure LS signal pressure. Install a flow meter in outlet line to measure pump flow.
2. Start Prime mover and allow fluid to reach normal operating temperature.
3. Totally lock the LS control; to do this first loosen the LS control lock nut and turn the LS control adjusting screw clockwise all the way to the end, while holding the LS control adjusting screw, torque the control lock nut to 21.6~24.6 N·m [191-218 lbf·in].
4. Adjust Power control and pressure compensated control (if used).

Adjustments

- After Step 4, slowly operate a hydraulic function that will demand approximately half flow from the pump, but keep outlet pressure below the power control pressure starting point (if Power control is used). Danfoss recommends loading the outlet pressure to 50bar.

Warning

Escaping hydraulic fluid under pressure can have sufficient force to penetrate your skin causing serious injury and/or infection. Relieve pressure in the system before removing hoses, fittings, gauges, or components.

Unintended movement of the machine or mechanism may cause injury to the technician or bystanders. To protect against unintended movement, secure the machine or disable / disconnect the mechanism while servicing.

Caution

Contamination can damage internal components and void the manufacturer's warranty. Take precautions to ensure system cleanliness when removing and reinstalling system lines.

- Loosen the LS control lock nut. While watching the pressure gauges, turn the LS control adjusting screw counterclockwise until the desired pressure differential between port **MB** and port **X** is achieved (LS setting). Clockwise rotation increases the setting, counterclockwise rotation will decrease it; approximate gain (see Table 1) per turn. While holding the position of the LS adjusting screw, torque the LS lock nut to 21.6~24.6 N·m [191-218 lbf·in].
- Stop the prime mover, remove the pressure gauge and flow meter, and return the system to its normal operating configuration.

TPES/TPE2 (130/145/193/260)

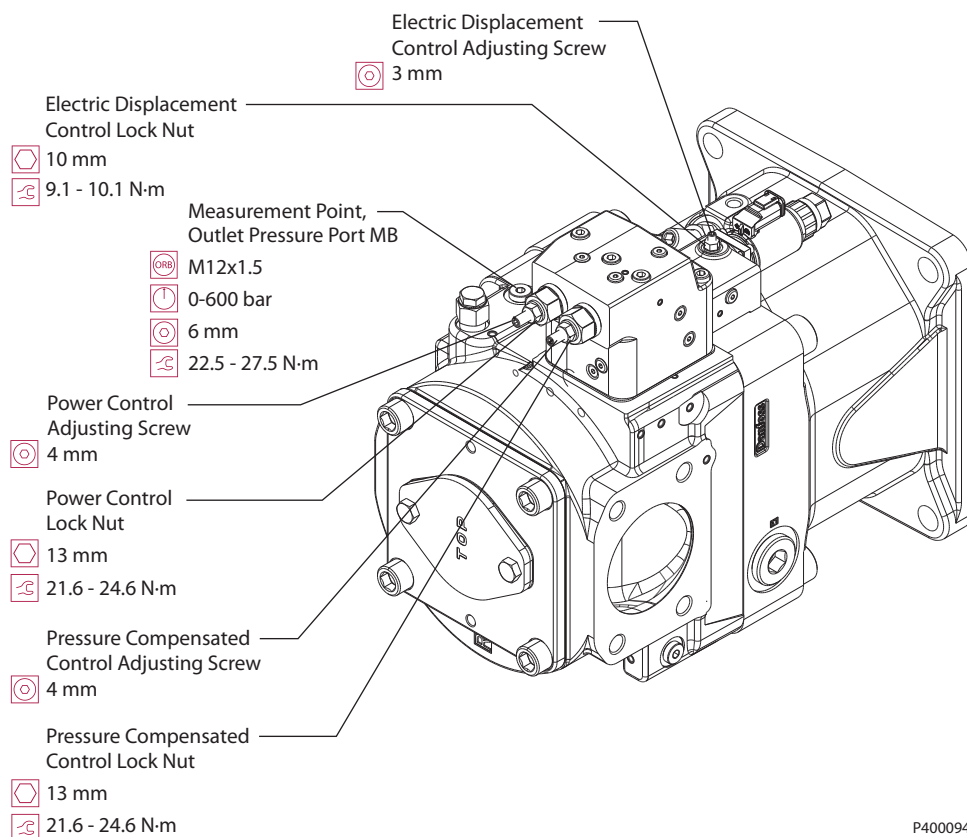

P400094

Adjustments

TPSN (65)

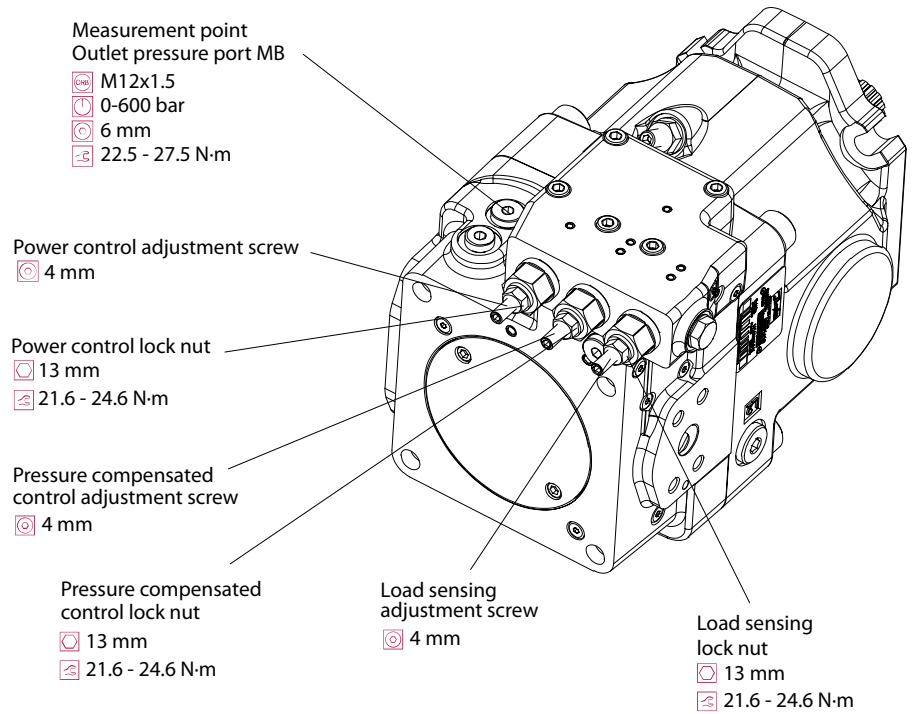

Adjustments

TPSN (130/145)

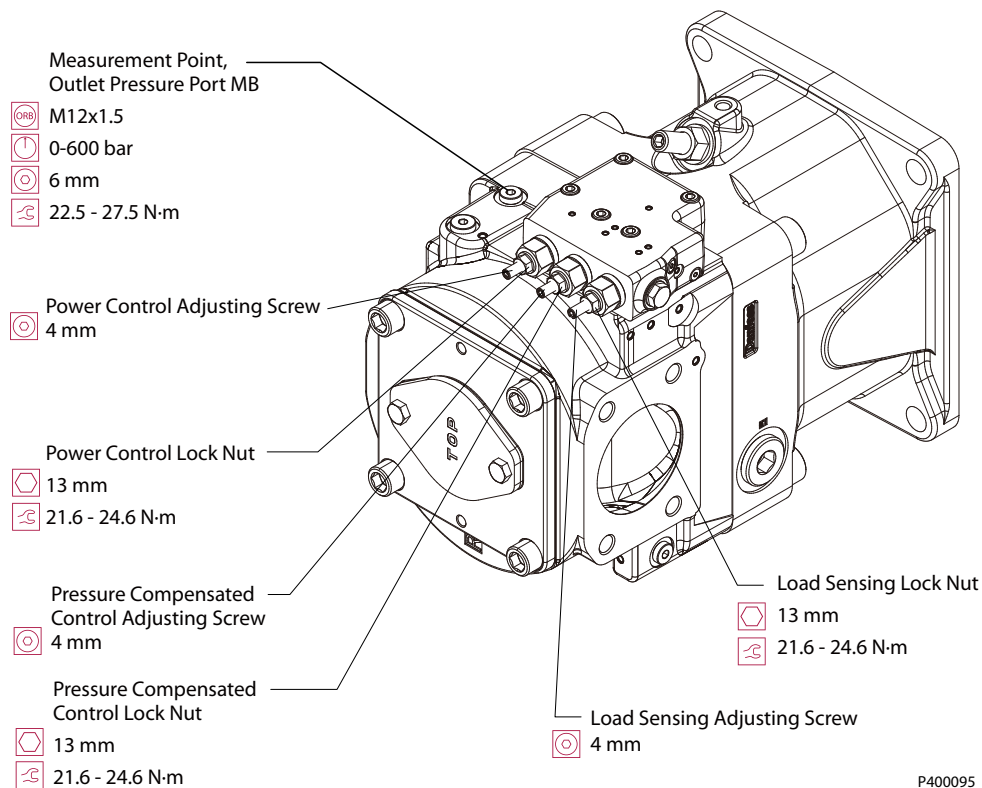

TPSN (193/260)

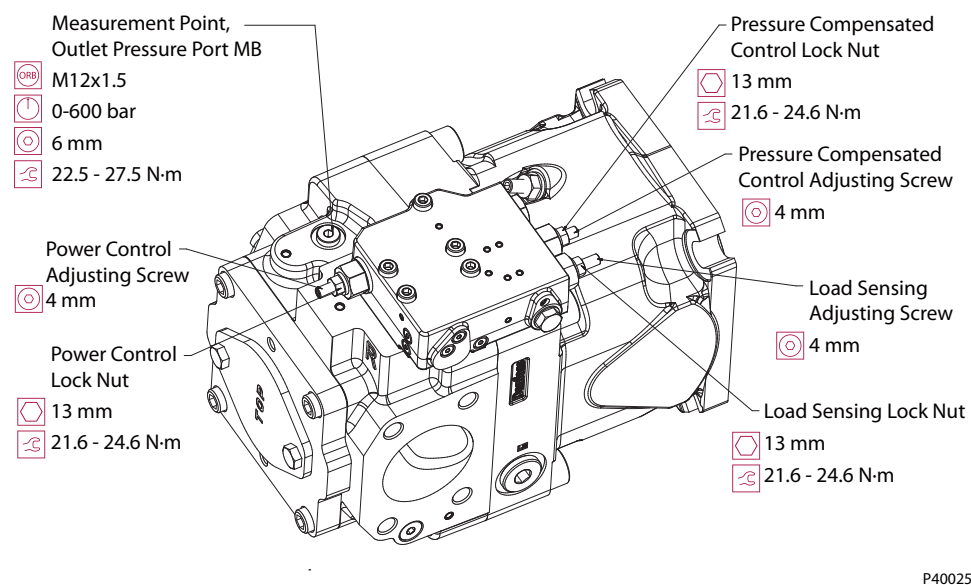

Please refer to [Operation](#) for information about the other control options.

Adjustments

Displacement Limiters Adjustment

Adjust Displacement Limiters

⚠ Warning

Escaping hydraulic fluid under pressure can have sufficient force to penetrate your skin causing serious injury and/or infection. Relieve pressure in the system before removing hoses, fittings, gauges, or components.

Unintended movement of the machine or mechanism may cause injury to the technician or bystanders. To protect against unintended movement, secure the machine or disable / disconnect the mechanism while servicing.

⚠ Caution

Contamination can damage internal components and void the manufacturer's warranty. Take precautions to ensure system cleanliness when removing and reinstalling system lines.

1. Install a flow meter in outlet line to measure pump flow.
2. Start the prime mover and allow fluid to reach normal operating temperature.
3. Adjust the control properly to make sure the pump at maximum displacement.
4. Loosen the maximum or minimum displacement limiter lock nut with an external hex wrench and turn the adjusting screw with an internal hex wrench until the desired flow is achieved.

Option	Description
Maximum displacement	<ul style="list-style-type: none"> • Clockwise turn decreases displacement • Counter-clockwise turn increases displacement
Minimum displacement	<ul style="list-style-type: none"> • Clockwise turn increases displacement • Counter-clockwise turn decreases displacement

Displacement change per turn

Displacement	65	130/145	193	260
Max. displacement change per turn	4.7cm ³ /rev	11 cm ³ /rev	15 cm ³ /rev	19 cm ³ /rev
Min. displacement change per turn	6cm ³ /rev	9 cm ³ /rev	14 cm ³ /rev	18 cm ³ /rev

5. While holding the position of the adjusting screw, torque the lock nut to required torque.

Wrench sizes and Torque

	65	130/145	193	260
Screws	5 mm	5 mm	8 mm	8 mm
Nuts	17 mm	17 mm	24 mm	24 mm
	43~48 N·m [380.58~424.84 lbf·in]	43~48 N·m [380.58~424.84 lbf·in]	180~206 N·m [1593.13~1823.25 lbf·in]	180~206 N·m [1593.13~1823.25 lbf·in]

Minor repairs

D1P shaft replacement

Replacing the shaft requires removing the pump from the machine. If a second pump is used, you must first remove it before working on the D1 pump. The shaft assembly is serviceable without disassembling the pump.

D1P shaft removal

Remove any auxiliary pad or running cover and the impeller (if used) using the following steps:

1. Set the pump on a working surface with the shaft facing down.
2. Remove the snap ring (G610) with snap-ring pliers, remove the impeller (G600) and another snap ring (G620) with snap-ring pliers.

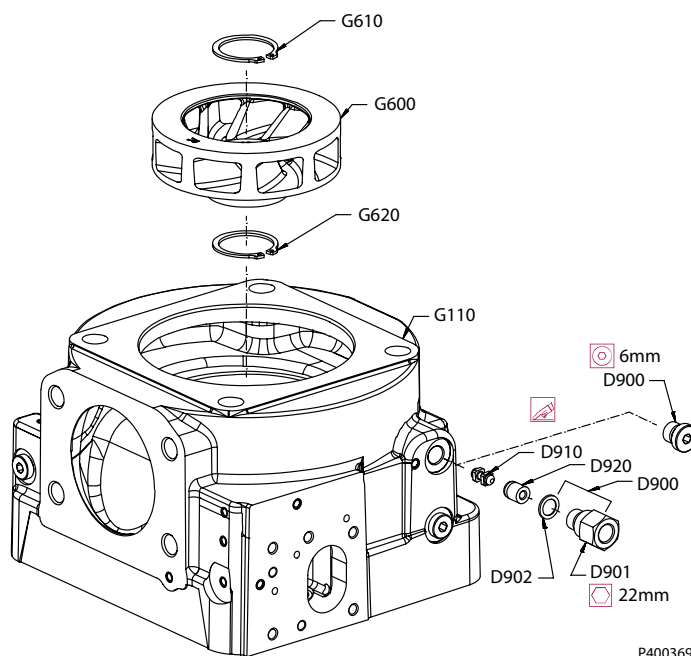

3. Turn the housing 180 degrees, mounting flange side up, remove the snap ring (F210) using snap-ring pliers.
4. Remove the shaft seal seal group (F220), remove and discard the O-ring (F230).

Shaft seal (F222) and carrier (F221) are set as one group. remove and discard group.

5. Danfoss recommends screwing in the max displacement limiter enough so to prevent internal component movement during the shaft removal. Remove shaft and front bearing assembly (E000T) after shaft seal group has been removed.

The shaft and front bearing sub-assembly are light pressed to the housing. For ease of removal, use a lift ring and a lifting device.

6. If front bearing removal is required, press it out of the shaft toward the rear end of the shaft.

Minor repairs

D1P shaft installation

1. Before reinstalling the shaft, press the shaft bearing onto shaft (if bearing was removed), using external snap ring pliers to install retainer ring (not shown, see Repair Instructions manual) in shaft.

! Caution

The washer from the bearing must be on the shaft shoulder side and the retainer ring must be facing the bearing with the small corner side.

2. With the pump's mounting flange side up, coat bearing hole with hydraulic fluid, install shaft and front bearing group to housing, knocking the bearing cup side lightly with a copper hammer if there is considerable resistance until the shaft and bearing assembly is properly set in place.

! Caution

Do not hit the shaft, using a protective sleeve is recommended. Be careful with contaminants during the process.

3. Coat with assembly grease to hold the O-ring (F230) in bearing hole.

! Caution

Be careful when touching shaft splines; The retainer ring must be facing the bearing with small corner side.

4. Lubricate the lip of the shaft seal (F222) with clean hydraulic grease. Install the carrier and seal assembly (F220) and make sure it is set properly by applying uniform force around the carrier. Once the seal carrier is properly set, use internal snap ring pliers to install retainer ring (F210) in housing.
5. If the pump has an impeller, reinstall it after the shaft installation is complete.

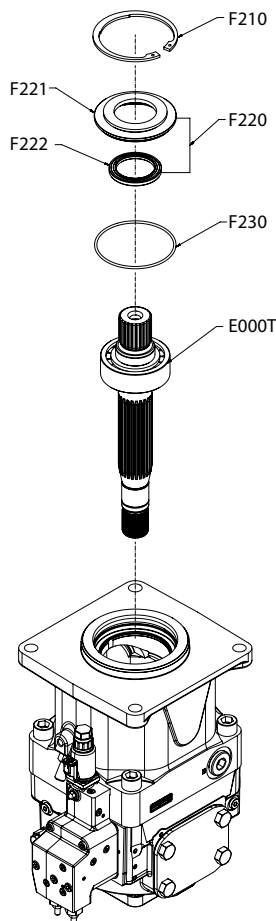

P400617

Minor repairs

Shaft Seal Replacement

D1 pump uses a lip-type shaft seal. You can replace this seal without major disassembly of the unit. Replacing the shaft seal requires removing the pump from the machine.

Removal

1. Using the appropriate snap-ring pliers, remove the retaining ring (F210) from the housing.
2. Remove the shaft seal and its carrier (F220) with appropriate tool (such as a flat-head screwdriver) from the bore in the pump housing and discard.
3. Remove the O-ring (F230) and discard.

Installation

1. Inspect the pump housing and new seals for damage. Inspect the sealing area on the shaft for rust, wear, or contamination. Polish the sealing area on the shaft if necessary.
2. Lubricate new O-ring (F230) with petroleum jelly and fit in the housing groove.
3. Lubricate the lip of the new shaft seal with clean hydraulic fluid. Place a protective sleeve over the shaft end to prevent damage to the seal during installation.
4. Keeping the new seal and its carrier perpendicular to the shaft, press them into the housing just far enough to clear the retaining ring groove. Install seal with the cupped side toward the shaft bearing. Do not damage the seal during installation.
5. Using the appropriate snap ring pliers, install the seal retaining ring.
6. Remove the installation sleeve.

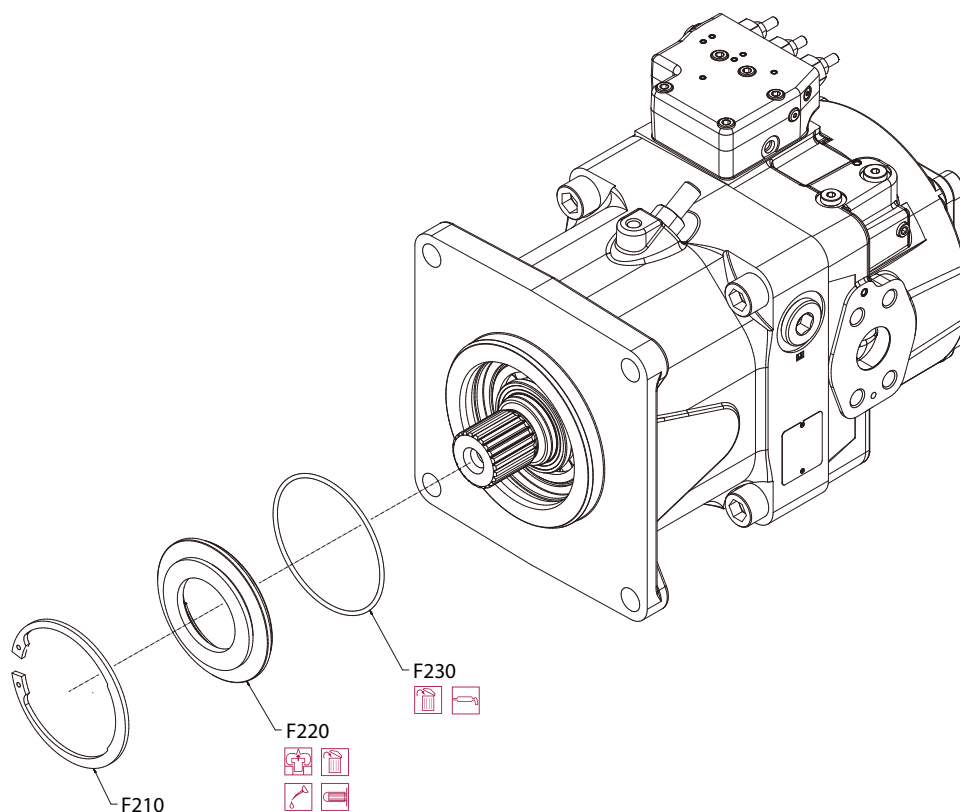

P400096

Minor repairs**Auxiliary Flange and Charge Pump Replacement**

Follow these steps to either remove, replace, or exchange auxiliary mounting pads and charge pump (impeller).

D1P auxiliary flange removal

1. Remove the screws (H140), retaining the cover plate (H150). Remove the seal (H130).
2. Remove the drive coupling (H200) if present.
3. Remove the 4 screws (H120), retaining the pad adapter (H100) to the end cap. Discard the pad adapter O-ring (H110).
4. Use the appropriate snap-ring pliers, remove the retaining ring (G610) from the shaft.
5. Pull out the charge pump, discard it if it is damaged.

D1P auxiliary flange installation

1. Push in the new charge pump far enough to clear the retaining ring groove (if impeller was replaced).
2. Use the appropriate snap-ring pliers to install retaining ring (G610) onto the shaft.
3. Lubricate new O-ring (H110) with petroleum jelly. Install the pad adapter to the end cap.
4. Install the 4 screws (H120) and torque to required torques.
5. Install the drive coupling (H200) if present.
6. Install the cover (H150) with seal (H130), lubricate the seal with petroleum jelly.
7. Install the screws (H140) and torque to required torques.

Minor repairs

130/145

All torques tolerance $\pm 10\%$

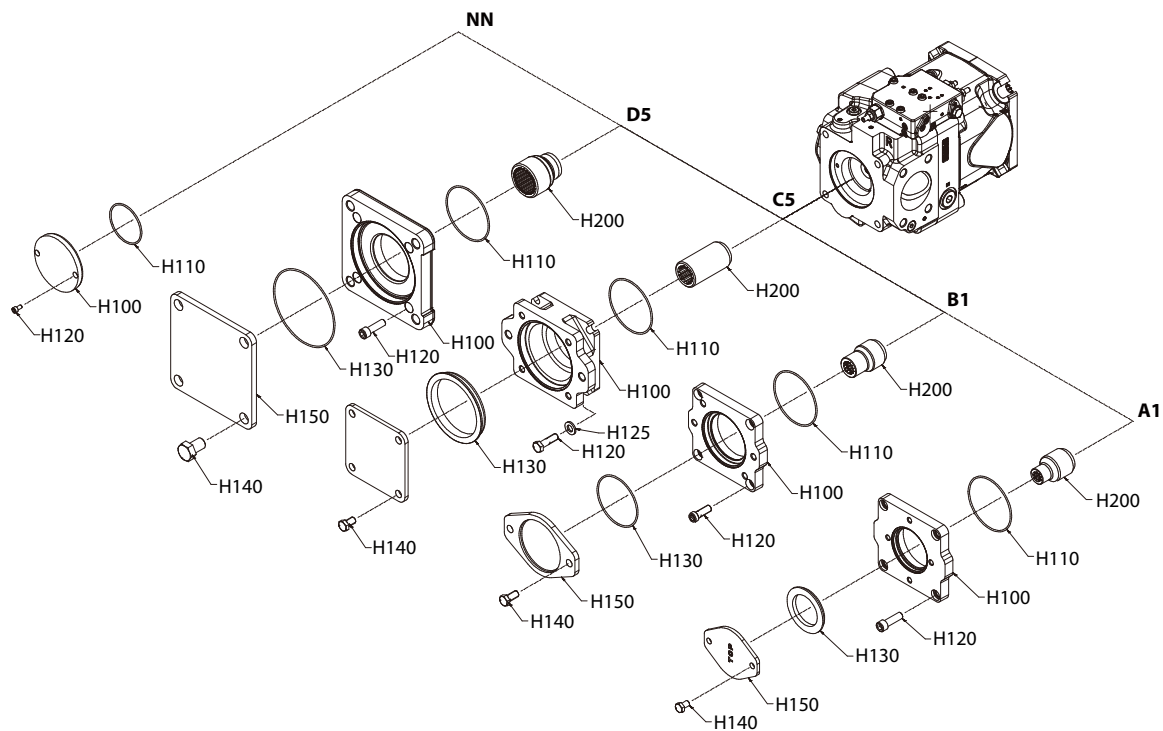

Minor repairs

Control (193/260)

Removal

1. Remove the control from the endcap by removing the mounting bolts (See *Control seal type and mounting bolts*). If the control has the TC/DC feedback link (D640), ensure that it does not stay in the hole of the bias piston in the endcap, remove it and place it with the control.
2. Remove and discard the seals (See *Control seal type and mounting bolts*).

Installation

1. Install new seals (See table *Control seal type and mounting bolts*). Proper gasket alignment is dictated by alignment pins in the control housing. For O-rings, lightly lubricate them prior to assembly.
2. If the control uses a TC/DC feedback link, make sure that it is set in the bias piston hole, then install the control housing assembly onto the endcap using the mounting bolts.

Control seal type and mounting bolts

Control	Seal type	Mounting bolts	TC/DC feedback link
NPNN (130-260)	Gasket (D145)	5 short bolts (D175)	No
NPSN (130-260)	Gasket (D145)	5 short bolts (D175)	No
TPSN (193/260)	Gasket (D145)	5 short bolts (D175)	Yes
TPSN (130/145)	1 O-ring (D140) & 3 O-rings (D150)	5 short bolts (D175)	Yes
NNES (130-260)	Gasket (D145)	5 short bolts (D175)	Yes
TPE2/TPE5 (130-260)	Gasket (D145)	3 long bolts (D170) & 2 short bolts (D180)	Yes
NPNR (130-260)	Gasket (D145)	5 short bolts (D175)	No

Torque requirements

Bolt	Torque
D175	22.5-27.5 N·m [199-243 lbf·in]
D170	22.5-27.5 N·m [199-243 lbf·in]
D180	22.5-27.5 N·m [199-243 lbf·in]

Minor repairs

193/260 TPE2 Control

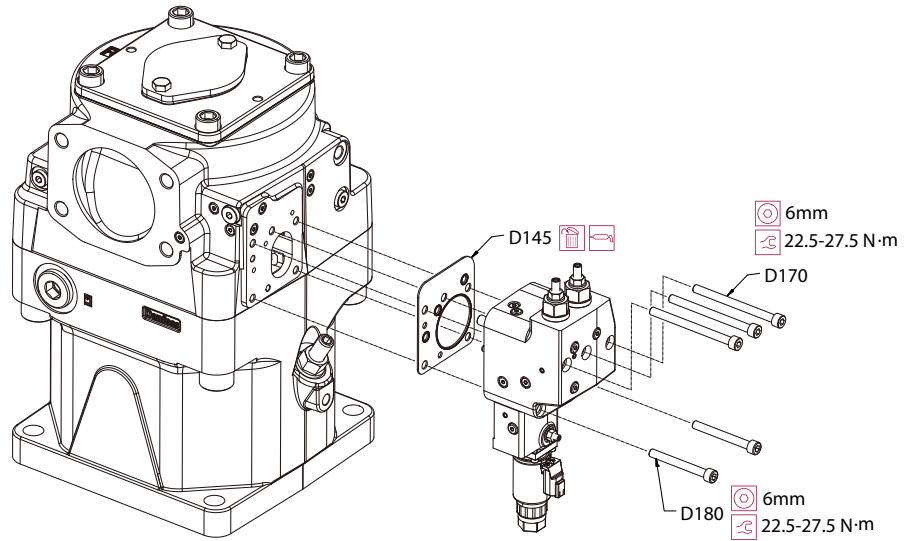

P400293

193/260 TPSN Control

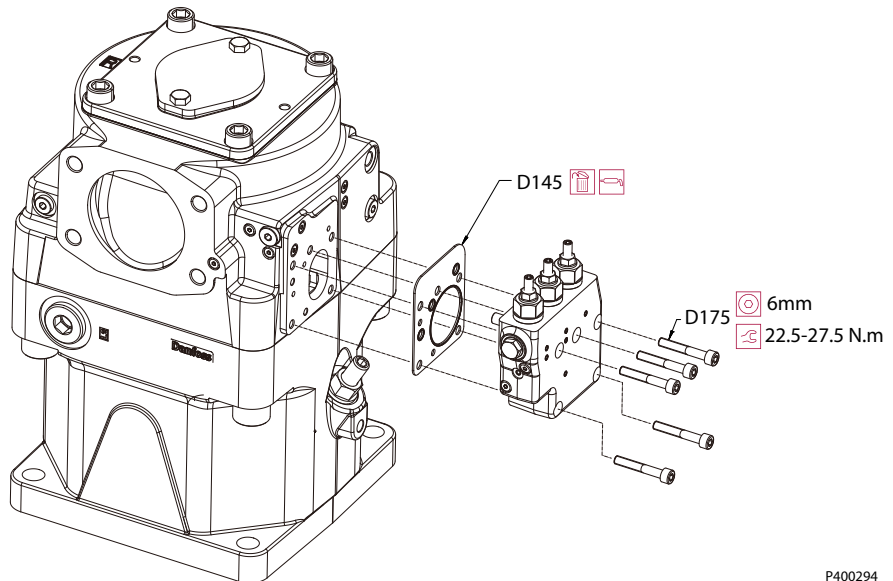

P400294

Minor repairs

Control (130/145)

130/145 TPSN Control

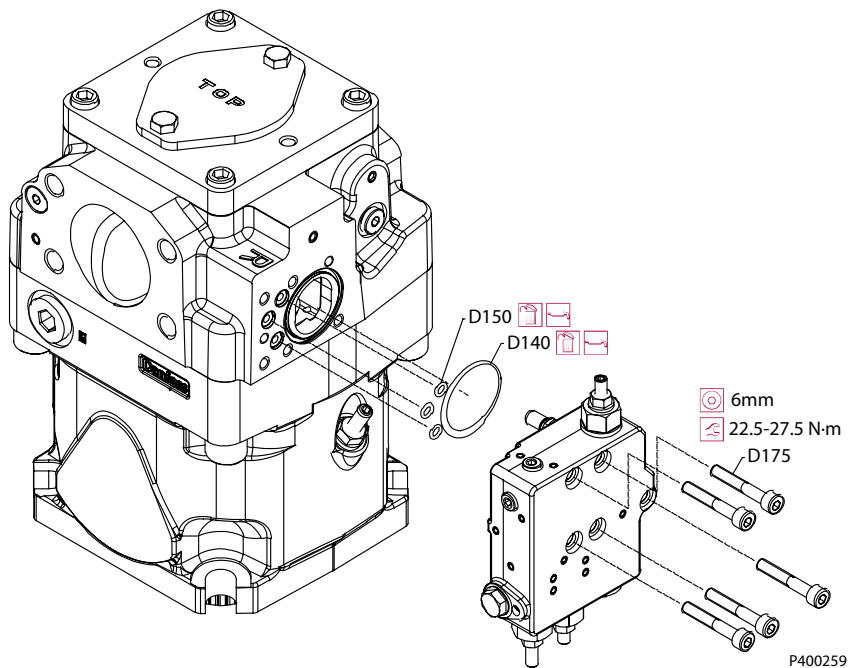

Minor repairs

Shuttle Valve or Plug

D1P shuttle valve or plug removal

Follow the steps below to remove the shuttle valve (if an EDC control is used) or plug.

1. For Electronic Displacement Control (EDC) function, first remove the plug assembly-HEX(D900).
2. Pull out shuttle valve seat (D920) with a M6 screw.
3. Remove the spool (D910) with an appropriate tool.
4. For controls without EDC function, there is only a plug which normally does not need to be removed.

D1P shuttle valve or plug installation

1. For controls with EDC, coat the shuttle valve spool (D910) with cleaning hydraulic oil and install to E port in the endcap.
2. Install shuttle valve seat (D920) according to the direction showing in the picture.
3. Install E port plug assembly (D900).
4. If the shuttle valve is not used, replace it with the plug (D900).

The shuttle valve must also be installed in NNES and TPE2/TPE5 controls if the application requires this feature. To determine if a shuttle valve is needed, please consult with your Danfoss representative.

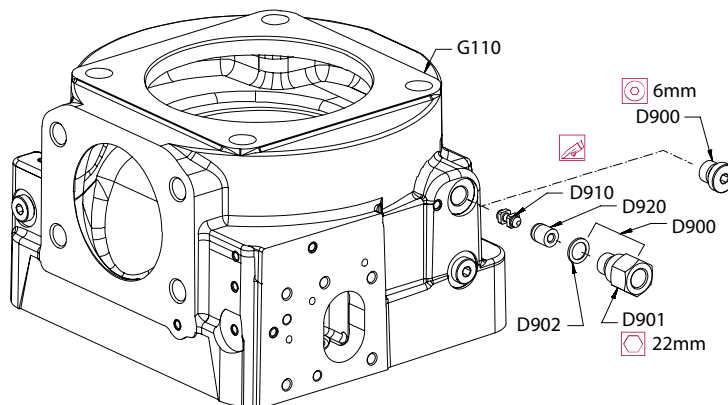

Edge Filter (260)

D1P edge filter removal

1. Remove the plug G255.
2. Remove the filter G254.

D1P edge filter installation

1. Install the filter G254 and torque to the required specification.

Minor repairs

2. Install the plug G255 and torque to the required specification.

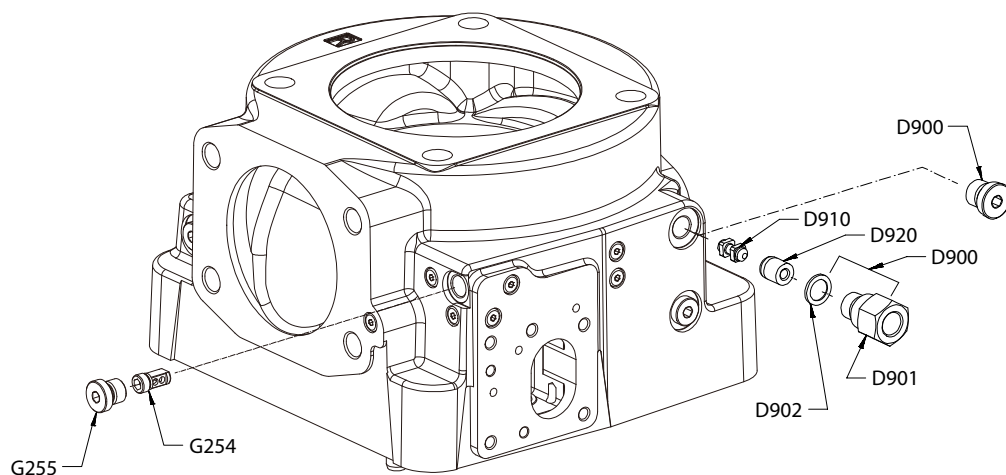

Wrench size and torque

Item	Wrench size	Torque
G254	6mm hex	9.9-12.1 Nm
G255	6mm hex	30.6-37.4 Nm
D900	6mm hex	30.6-37.4 Nm
D901	22mm hex	30.6-37.4 Nm

Minor repairs

Displacement Limiters

D1P displacement limiter screws removal

The removal steps of the maximum (bottom of the pump) and minimum (top of the pump, control side) are the same.

1. Loosen the lock nut (F120) with an external hex wrench.
2. Counter clockwise turn the adjusting screw (F110) with an 8mm internal hex wrench until it completely out.
3. Inspect the lock nut seal and adjusting screw, if they are damaged , discard them.

D1P displacement limiter screws installation

The installation steps of the maximum (bottom of the pump) and minimum (top of the pump) are the same.

1. Clockwise turn the adjusting screw (F110) with the appropriate internal hex wrench until you feel it start against the swashplate.
2. Install the lock nut (F120), while holding the adjusting screw position, torque the lock nut to required torque.

Wrench size and torque

Frame size	Wrench size	Torque
65cc	5 mm (screws), 17 mm (nuts)	43~48 N·m [380.58~424.84 lbf·in]
130/145cc	5 mm (screws) 17 mm (nuts)	43~48 N·m [380.58~424.84 lbf·in]
193cc	8 mm (screws), 24 mm (nuts)	180~206 N·m [1593.13~1823.25 lbf·in]
260cc	8 mm (screws), 24 mm (nuts)	180~206 N·m [1593.13~1823.25 lbf·in]

Minor repairs

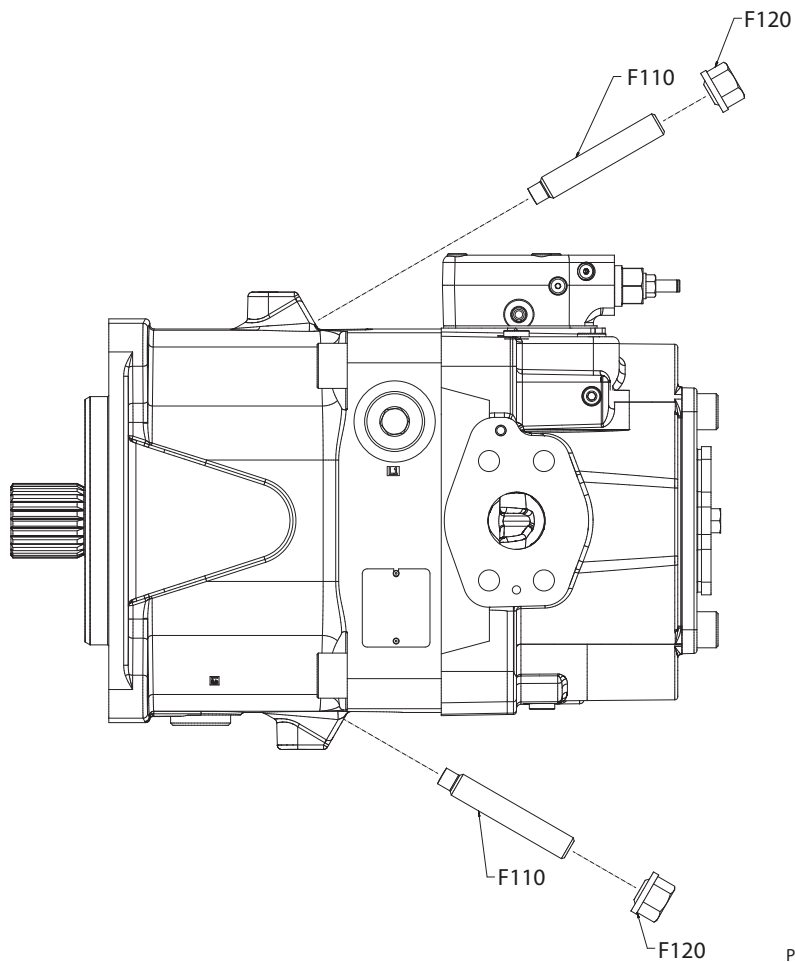

P400265

Minor repairs

Plug and fitting installation

If any plugs or fittings are removed from the unit during service, install and torque as indicated. The following drawings are in generic configurations to show item number for wrench size and torque reference.

D1P 193 TPE2 control plug fittings

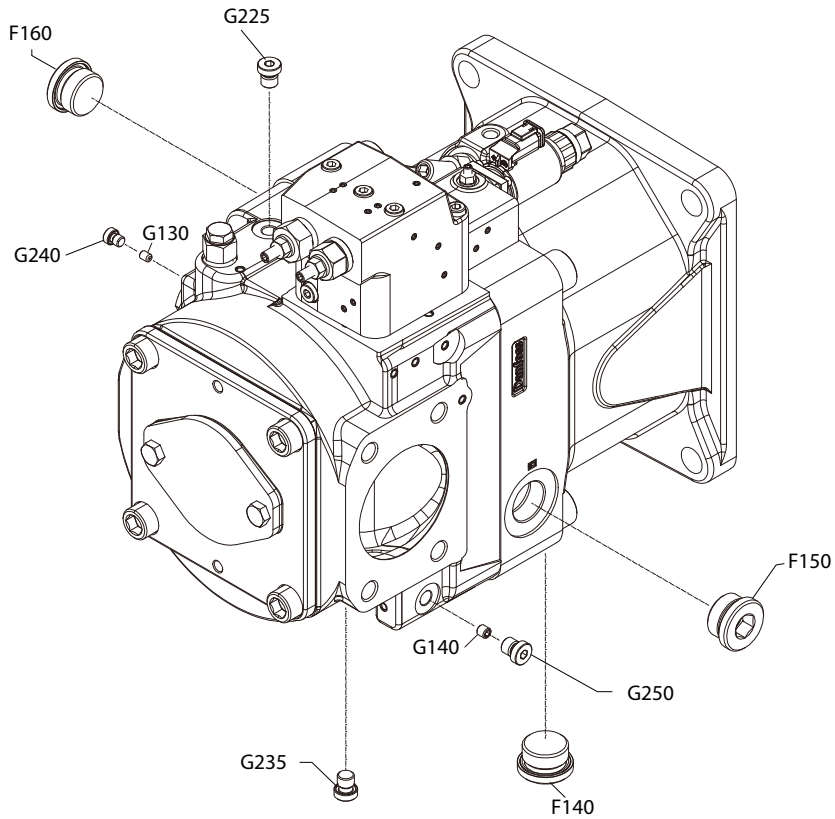

Plug fitting reference

Item	Description	Wrench size	Torque
F160	Drain port L1 (M33 x 2)	17 mm hex	68.4-83.6 Nm
G225	Outlet pressure test port MB (M12 x 1.5)	6 mm hex	22.5-27.5 Nm
G230	Bias orifice	3 mm hex	3.6-4.4 Nm
G240	Bias orifice plug (M8 x 1)	4 mm hex	9.9-12.1 Nm
G235	Servo pressure test port M4 (M12 x 1.5)	6 mm hex	22.5-27.5 Nm
G140	Servo orifice	4 mm	3.6-4.4 Nm
F140	Drain port L3 (M33 x 2)	17 mm hex	68.4-83.6 Nm
F150	Drain port L2 (M33 x 2)	17 mm hex	68.4-83.6 Nm
G250	Servo orifice plug (M12 x 1.5)	6 mm hex	22.5-27.5 Nm

Minor repairs

D1P 260 TPE2 control plug fittings

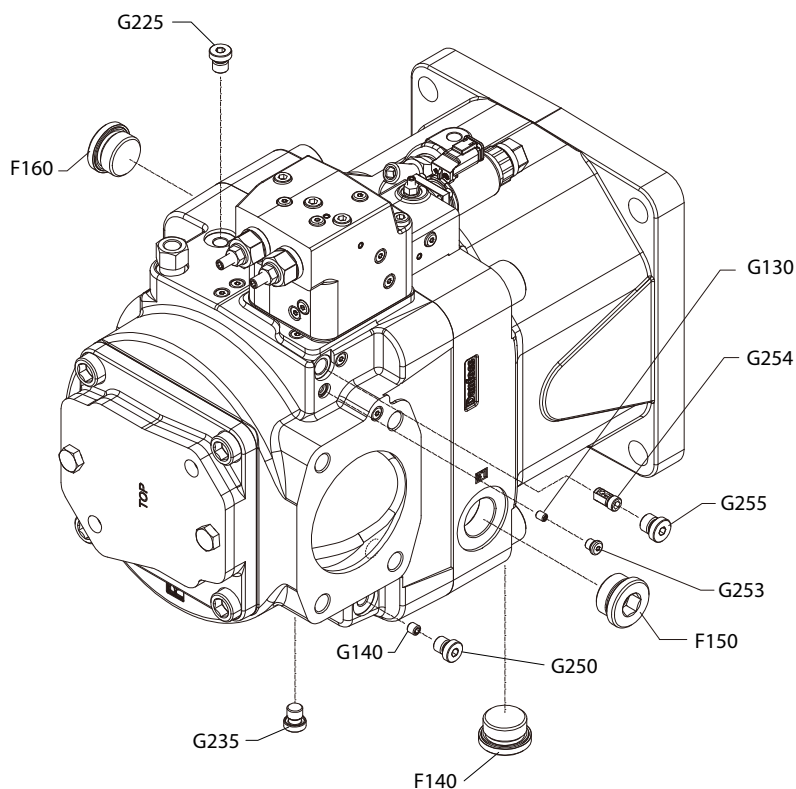

Plug fitting reference

Item	Description	Wrench size	Torque
G130	Bias orifice	3 mm hex	3.6-4.4 Nm
G140	Servo orifice	4 mm	3.6-4.4 Nm
G225	Outlet pressure test port MB (M12 x 1.5)	6 mm hex	22.5-27.5 Nm
G235	Servo pressure test port M4 (M12 x 1.5)	6 mm hex	22.5-27.5 Nm
G250	Servo orifice plug (M12 x 1.5)	6 mm hex	22.5-27.5 Nm
G253	Bias orifice plug (5/16 - 24 UNF-2A)	1/8 in	9.9-12.1 Nm
G254	Edge filter	6 mm hex	9.9-12.1 Nm
G255	Edge filter plug (M14 x 1.5)	6 mm hex	30.6-37.4 Nm
F140	Drain port L3 (M33 x 2)	17 mm hex	68.4-83.6 Nm
F150	Drain port L2 (M33 x 2)	17 mm hex	68.4-83.6 Nm
F160	Drain port L1 (M33 x 2)	17 mm hex	68.4-83.6 Nm

Minor repairs

D1P 130/145 TPSN control plug fittings

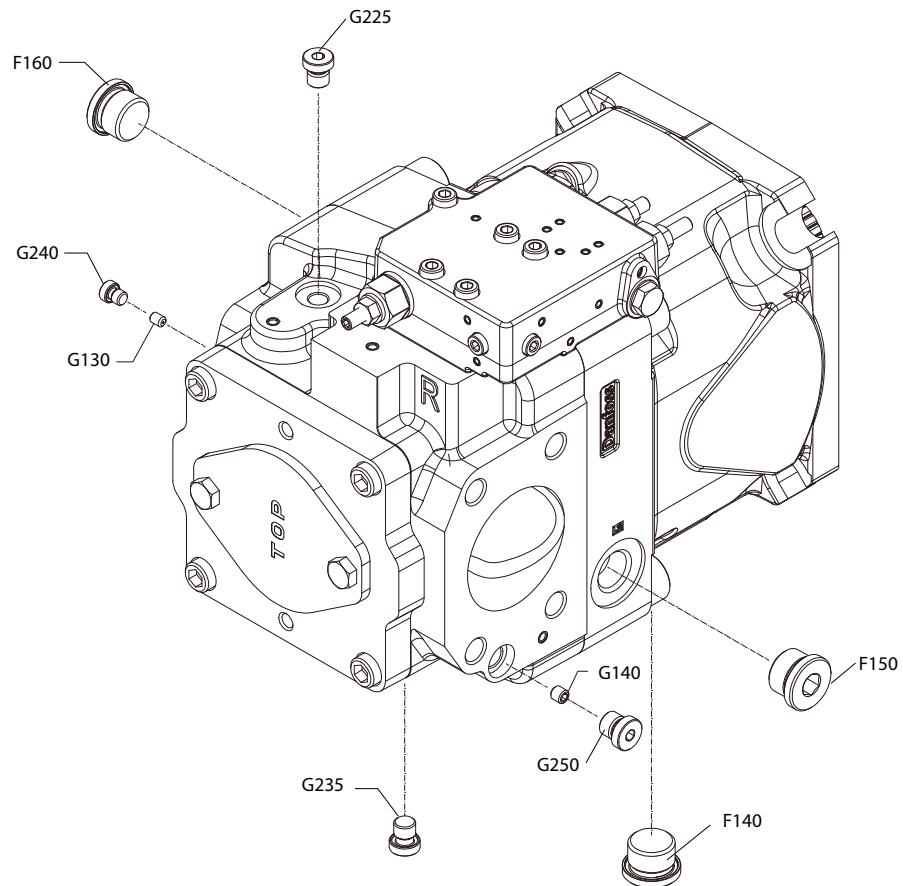

Plug fitting reference

Item	Description	Wrench size	Torque
G130	Bias orifice	3 mm hex	3.6-4.4 Nm
G140	Servo orifice	4 mm	3.6-4.4 Nm
G225	Outlet pressure test port MB (M12 x 1.5)	6 mm hex	22.5-27.5 Nm
G235	Servo pressure test port M4 (M12 x 1.5)	6 mm hex	22.5-27.5 Nm
G250	Servo orifice plug (M14 x 1.5)	6 mm hex	30.6-37.4 Nm
F140	Drain port L3 (M26 x 1.5)	12 mm hex	68.4-83.6 Nm
F150	Drain port L2 (M26 x 1.5)	12 mm hex	68.4-83.6 Nm
F160	Drain port L1 (M26 x 1.5)	12 mm hex	68.4-83.6 Nm

Minor repairs

D1P plugs and fasteners

Size 193/260

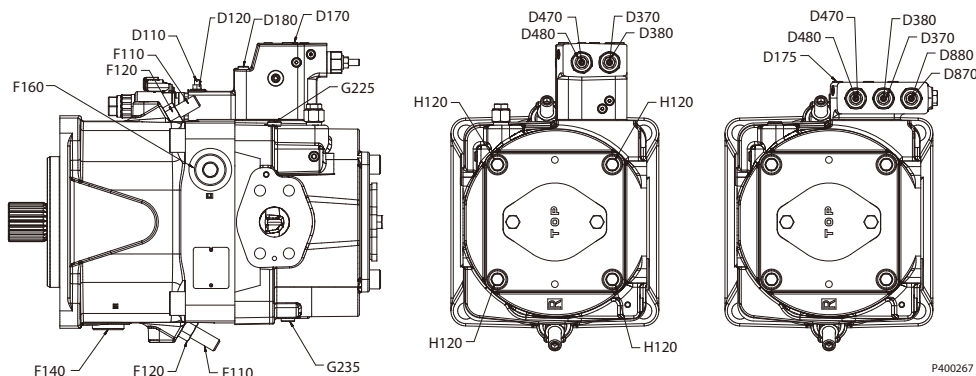

Size 130/145

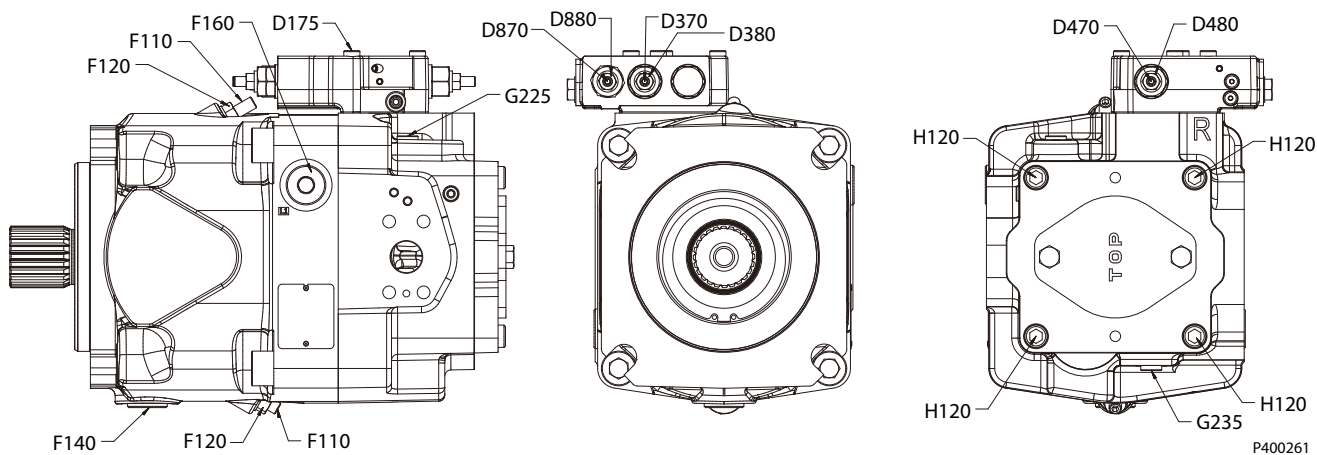

D1P fastener size and torque chart

All torques tolerance (except already given range) : ±10%

Item	Fastener	65		130/145		193		260	
		Wrench size	Torque	Wrench size	Torque	Wrench size	Torque	Wrench size	Torque
D170 D180	Control assembly screws	N/A	N/A	6 mm internal hex	25 N·m [221.27 lbf·in]	6 mm internal hex	25 N·m [221.27 lbf·in]	6 mm internal hex	25 N·m [221.27 lbf·in]
D175	Control assembly screws	6 mm internal hex	25 N·m [221.27 lbf·in]	6 mm internal hex	25 N·m [221.27 lbf·in]	6 mm internal hex	25 N·m [221.27 lbf·in]	6 mm internal hex	25 N·m [221.27 lbf·in]
H120	Adapter screws		N/A	10 mm internal hex	130 N·m [1150.6 lbf·in]	14 mm internal hex	215 N·m [1902.91 lbf·in]	14 mm internal hex	215 N·m [1902.91 lbf·in]
F110	Displacement limiter screws	5 mm internal hex	N/A	5 mm internal hex	N/A	8 mm internal hex	N/A	8 mm internal hex	N/A
D370	P adjusting screw	4 mm internal hex	N/A	4 mm internal hex	N/A	4 mm internal hex	N/A	4 mm internal hex	N/A
D470	T adjusting screw	4 mm internal hex	N/A	4 mm internal hex	N/A	4 mm internal hex	N/A	4 mm internal hex	N/A

Minor repairs
All torques tolerance (except already given range) : ±10% (continued)

Item	Fastener	65		130/145		193		260	
		Wrench size	Torque	Wrench size	Torque	Wrench size	Torque	Wrench size	Torque
D870	S adjusting screw	4 mm internal hex	N/A	4 mm internal hex	N/A	4 mm internal hex	N/A	4 mm internal hex	N/A
D110	E2 adjusting screw		N/A	N/A	N/A	3 mm internal hex	N/A	3 mm internal hex	N/A
F120	Displacement limiter lock nuts	17 mm external hex	43 -48 N·m [380.58-424.8 4 lbf·in]	17 mm external hex	43 -48 N·m [380.58-424.8 4 lbf·in]	24 mm external hex	180 - 206 N·m [1593.13-182 3.25 lbf·in]	24 mm external hex	180 - 206 N·m [1593.13-182 3.25 lbf·in]
D380	P locknut	13 mm external hex	21.6-24.6 N·m [191.18-217.7 3 lbf·in]	13 mm external hex	21.6-24.6 N·m [191.18-217.7 3 lbf·in]	13 mm external hex	21.6-24.6 N·m [191.18-217.7 3 lbf·in]	13 mm external hex	21.6-24.6 N·m [191.18-217.7 3 lbf·in]
D480	T locknut	13 mm external hex	21.6-24.6 N·m [191.18-217.7 3 lbf·in]	13 mm external hex	21.6-24.6 N·m [191.18-217.7 3 lbf·in]	13 mm external hex	21.6-24.6 N·m [191.18-217.7 3 lbf·in]	13 mm external hex	21.6-24.6 N·m [191.18-217.7 3 lbf·in]
D880	S locknut	13 mm external hex	21.6-24.6 N·m [191.18-217.7 3 lbf·in]	13 mm external hex	21.6-24.6 N·m [191.18-217.7 3 lbf·in]	13mm external hex	21.6-24.6 N·m [191.18-217.7 3 lbf·in]	13mm external hex	21.6-24.6 N·m [191.18-217.7 3 lbf·in]
D120	E2/E5 locknut	N/A	N/A	10 mm external hex	9.1-10.1 N·m [80.54-89.39 lbf·in]	10 mm external hex	9.1-10.1 N·m [80.54-89.39 lbf·in]	10 mm external hex	9.1-10.1 N·m [80.54-89.39 lbf·in]

D1P plug size and torque chart
All torques tolerance (except already given range) : ±10%

Item	65			130/145			193			260		
	ED-ring plug	Wrench size	Torque	ED-ring plug	Wrench size	Torque	ED-ring plug	Wrench size	Torque	ED-ring plug	Wrench size	Torque
F140 F150	N/A	N/A	N/A	M26X1.5	12 mm internal hex	76 N·m [672.66 lbf·in]	M33X2	17 mm internal hex	225 N·m [1991.42 lbf·in]	M33X2	17 mm internal hex	225 N·m [1991.42 lbf·in]
G225 G235	M12X1.5	6 mm internal hex	25 N·m [221.27 lbf·in]	M12X1.5	6 mm internal hex	25 N·m [221.27 lbf·in]	M12X1.5	6 mm internal hex	25 N·m [221.27 lbf·in]	M12X1.5	6 mm internal hex	25 N·m [221.27 lbf·in]

Products we offer:

- DCV directional control valves
- Electric converters
- Electric machines
- Electric motors
- Hydrostatic motors
- Hydrostatic pumps
- Orbital motors
- PLUS+1® controllers
- PLUS+1® displays
- PLUS+1® joysticks and pedals
- PLUS+1® operator interfaces
- PLUS+1® sensors
- PLUS+1® software
- PLUS+1® software services, support and training
- Position controls and sensors
- PVG proportional valves
- Steering components and systems
- Telematics

Danfoss Power Solutions is a global manufacturer and supplier of high-quality hydraulic and electric components. We specialize in providing state-of-the-art technology and solutions that excel in the harsh operating conditions of the mobile off-highway market as well as the marine sector. Building on our extensive applications expertise, we work closely with you to ensure exceptional performance for a broad range of applications. We help you and other customers around the world speed up system development, reduce costs and bring vehicles and vessels to market faster.

Danfoss Power Solutions – your strongest partner in mobile hydraulics and mobile electrification.

Go to www.danfoss.com for further product information.

We offer you expert worldwide support for ensuring the best possible solutions for outstanding performance. And with an extensive network of Global Service Partners, we also provide you with comprehensive global service for all of our components.

Hydro-Gear

www.hydro-gear.com

Daikin-Sauer-Danfoss

www.daikin-sauer-danfoss.com

Local address:

**Danfoss
Power Solutions (US) Company**
2800 East 13th Street
Ames, IA 50010, USA
Phone: +1 515 239 6000

**Danfoss
Power Solutions GmbH & Co. OHG**
Krokamp 35
D-24539 Neumünster, Germany
Phone: +49 4321 871 0

**Danfoss
Power Solutions ApS**
Nordborgvej 81
DK-6430 Nordborg, Denmark
Phone: +45 7488 2222

**Danfoss
Power Solutions Trading
(Shanghai) Co., Ltd.**
Building #22, No. 1000 Jin Hai Rd
Jin Qiao, Pudong New District
Shanghai, China 201206
Phone: +86 21 3418 5200

Danfoss can accept no responsibility for possible errors in catalogues, brochures and other printed material. Danfoss reserves the right to alter its products without notice. This also applies to products already on order provided that such alterations can be made without subsequent changes being necessary in specifications already agreed. All trademarks in this material are property of the respective companies. Danfoss and the Danfoss logotype are trademarks of Danfoss A/S. All rights reserved.