

Contents

	Page
Function	53
Filter drier selection.....	53
Location in refrigeration system.....	54
Installation	55
Soldering.....	56
Operation	56
Replace the filter drier when	56
DCR	57
Using gaskets.....	57
Mounting gaskets.....	57
Disposal.....	57
Filter drier replacement	57
Special filters from Danfoss	58
Combidriers type DCC and DMC.....	58
Burn-out filter, type 48-DA	58
Special application	58
DCL/DML filter driers.....	58
Dimensioning	59
EPD (Equilibrium Point Dryness).....	59
Drying capacity (water capacity).....	59
Liquid capacity (ARI 710*)	59
Recommended system capacity	60
Filter driers from Danfoss	60

Notes

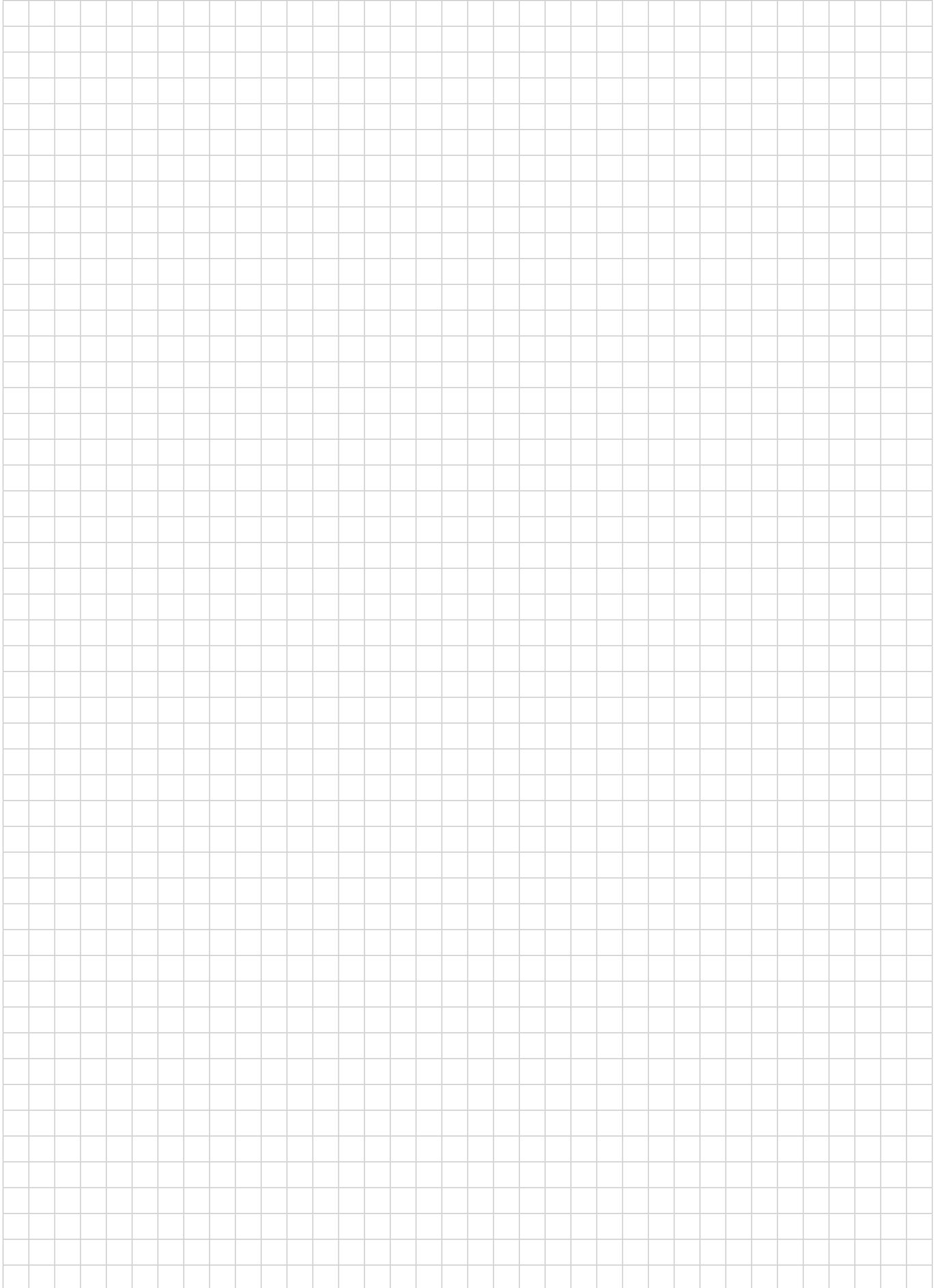

Function

To ensure optimum function the refrigeration system must be internally clean and dry.

Before starting the system, moisture must be removed by evacuation at a max. pressure of 0.05 mbar abs.

During operation, dirt and moisture must be collected and removed. This is performed by a filter drier containing a solid core consisting of:

- Molecular Sieves
- Silica gel (low effectiveness - not used in Danfoss driers)
- Activated aluminium oxide and a polyester mesh A inserted in the filter outlet.

DML: 100% Molecular Sieves

DCL: 80% Molecular Sieves
20% Activated aluminium

The solid core can be compared to a sponge's ability to soak up water and retain it.

Molecular Sieves retain water, whereas activated aluminium oxide retains water and acids.

The solid core B together with the polyester mat A also acts as a dirt filter.

The solid core retains large dirt particles and the polyester mat small ones.

The filter drier is thus able to collect all dirt particles larger than 25 micron.

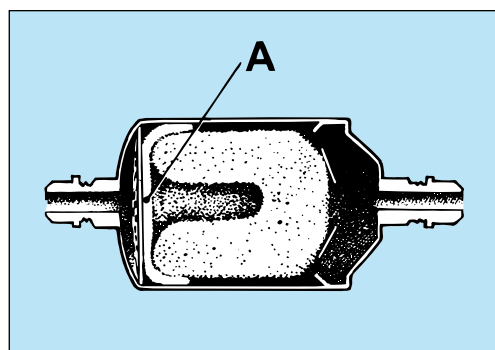

Ah0_0001

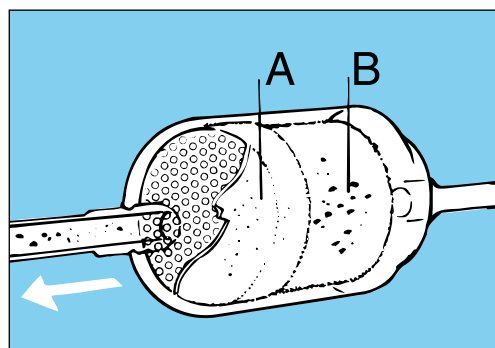

Ah0_0011

Filter drier selection

The filter drier must be selected to suit the connections and the capacity of the refrigeration system.

If a filter drier with solder connections is required, a Danfoss type DCL/DML filter drier can be used to advantage. It has an extra-high drying capacity which prolongs the interval between replacements.

A collar on the connector A indicates that the connection is a mm size. If the connector A is plain, i.e. no collar, the connector is an inch size. Type DCL can be used for CFC/HCFC refrigerants. Type DML can be used for HFC refrigerants. See page 60 for more details.

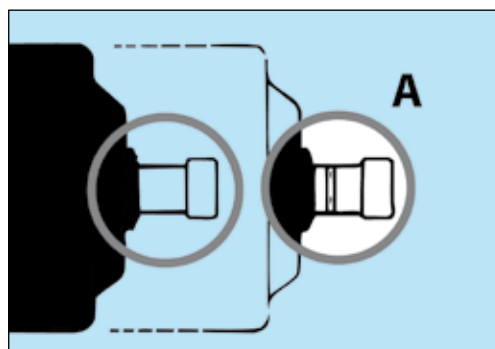

Ah0_0018

Location in refrigeration system

The filter drier is normally installed in the liquid line where its primary function is to protect the expansion valve.

The velocity of the refrigerant in the liquid line is low and therefore contact between the refrigerant and the solid core in the filter drier is good. At the same time, the pressure drop across the filter drier is low.

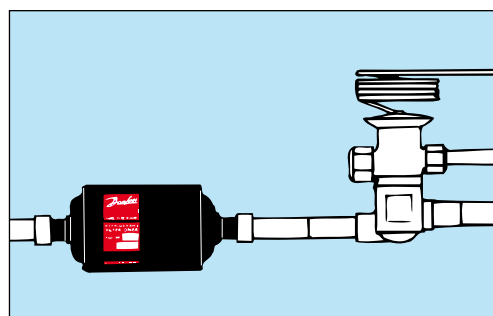

Ah0_0019

A filter drier can also be installed in the suction line where its task is to protect the compressor against dirt and dry the refrigerant.

Suction filters, so-called "burn-out" filters, are used to remove acids after motor damage. To ensure low pressure drop, a suction filter must normally be larger than a liquid line filter.

A suction filter must be replaced before the pressure drop exceeds the following values:

- A/C systems: 0.50 bar
- Refrigeration systems: 0.25 bar
- Freezing systems: 0.15 bar

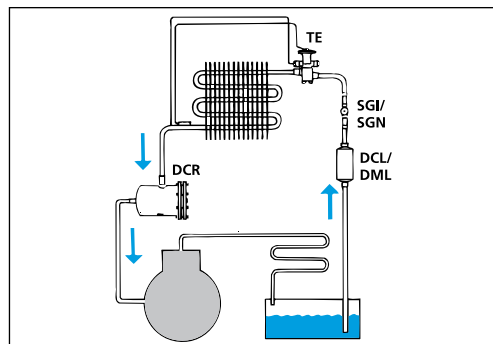

Ah0_0020

A sight glass with moisture indicator is normally installed after the filter drier, where the sight glass indication means:

Green: No dangerous moisture in the refrigerant.
 Yellow: Moisture content too high in the refrigerant ahead of the expansion valve.

Bubbles:

- 1) Pressure drop across the filter drier too high.
- 2) No subcooling.
- 3) Insufficient refrigerant in whole system.

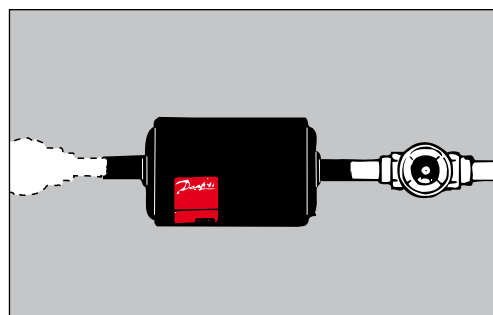

Ah0_0032

If the sight glass is installed ahead of the filter drier the indication is:

Green: No dangerous moisture in the refrigerant.
 Yellow: Moisture content in the whole refrigeration system too high.

The changeover point from green to yellow in the sight glass indicator is determined by the water solubility of the refrigerant.

Note:

The changeover points in Danfoss sight glasses are very small. This ensures that a switch to green in the indicator only occurs when the refrigerant is dry.

Bubbles:

- 1) No subcooling.
- 2) Insufficient refrigerant in whole system.

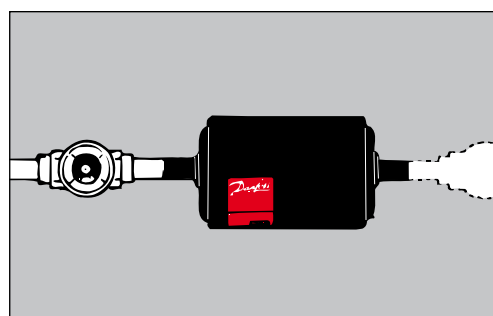

Ah0_0031

Note!

Do not replenish refrigerant solely because of bubbles in the sight glass.
 First find out the cause of the bubbles!



Ah0_0006

Installation

The filter drier must be installed with flow in the direction of the arrow on the filter drier label.

The filter drier can have any orientation, but the following must be remembered:

Vertical mounting with downward flow means rapid evacuation/emptying of the refrigeration system.

With vertical mounting and upward flow, evacuation/emptying takes longer because refrigerant must be evaporated out of the filter drier.

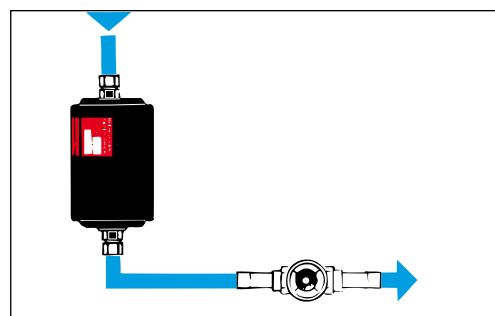

Ah0_0022

The filter core is firmly fixed in the filter housing. Danfoss filter driers are therefore able to resist vibration up to 10 g*).

Find out whether the tubing will support the filter drier and resist vibration. If not, the filter drier must be installed using a clamping band or similar secured to a rigid part of the system.

*) 10 g = Ten times the gravitational force of the earth.

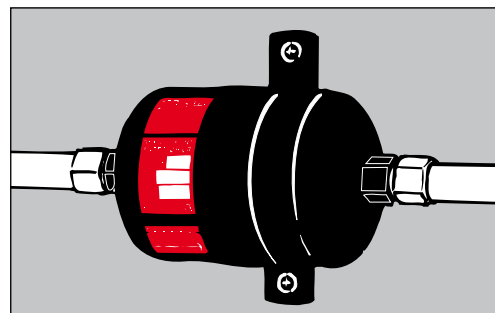

Ah0_0028

For DCR: Install with the inlet connector upwards or horizontal.

This avoids collected dirt running out into the tubing when the core is replaced.

When installing a new DCR, remember that there must always be sufficient space for core replacement.

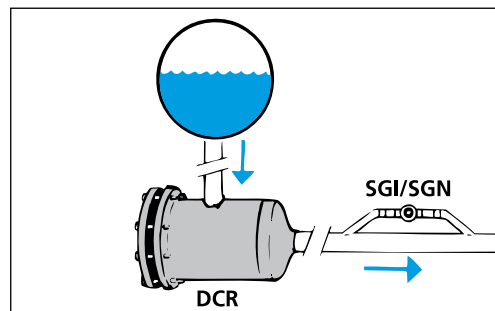

Ah0_0002

Do not unpack filter driers or cores until immediately before installation. This will safe-guard the items in the best possible way.

There is neither vacuum nor overpressure in filters or cans.

Plastic union nuts, capsolutes and the hermetically sealed can guarantee completely "fresh" desiccants.

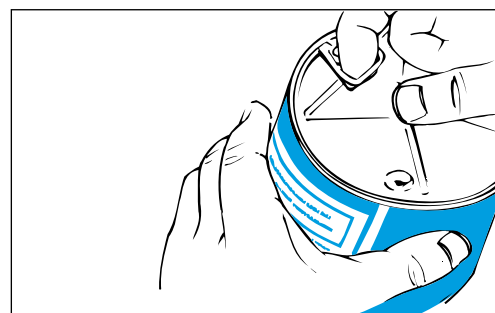

Ah0_0003

Soldering

Protective gas, e.g. N₂, should be used when soldering the filter drier.
 Ensure that the protective gas flows in the direction of filter flow. This avoids heat from soldering being damaging the polyester mesh.

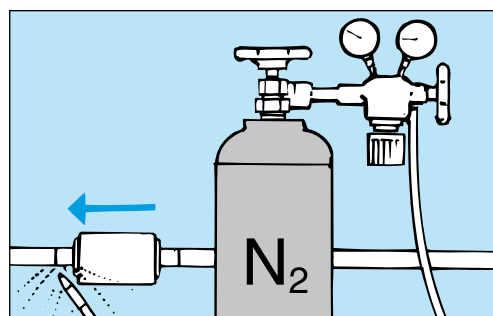

Ah0_0004



Soldering alloys and flux give off fumes that can be hazardous. Read supplier instructions and observe their safety stipulations. Keep your head away from the fumes during soldering.

Use strong ventilation and/or extraction at the flame so that you do not inhale fumes and gases. Use protective goggles. Use wet cloth around filter driers with pure copper connectors.

Operation

- Moisture enters the system:
- 1) When the refrigeration system is being built up.
 - 2) When the refrigeration system is opened for servicing.
 - 3) If leakage occurs on the suction side, if it is under vacuum.
 - 4) When the system is filled with oil or refrigerant containing moisture.
 - 5) If leakage occurs in a water-cooled condenser.

- Moisture in the refrigeration system can cause:
- a) Blockage of the expansion device because of ice formation.
 - b) Corrosion of metal parts.
 - c) Chemical damage to the insulation in hermetic and semihermetic compressors.
 - d) Oil breakdown (acid formation).

The filter drier removes moisture that remains after evacuation or that subsequently enters the refrigeration system.



Ah0_0005



Warning!
 Never use "antifreeze liquids" like methyl alcohol together with a filter drier. Such liquid can damage the filter so that it is unable to absorb water and acid.

Replace the filter drier when

1. The sight glass indicates that the moisture content is too high (yellow).
2. Pressure drop across the filter is too high (bubbles in sight glass during normal operation).
3. A main component in the refrigerant system has been replaced, e.g. the compressor.
4. Each time the refrigeration system is otherwise opened, e.g. if the orifice assembly in an expansion valve is replaced.

Never re-use a used filter drier. It will give off moisture if it is used in a refrigeration system with low moisture content, or if it becomes heated.

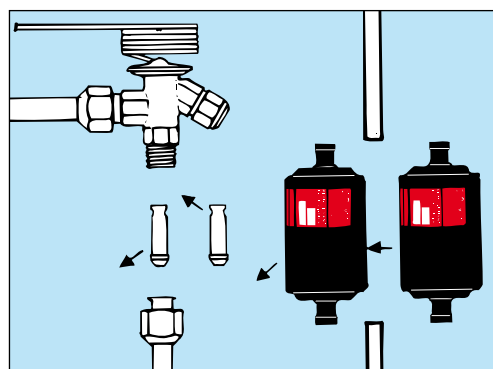

Ah0_0008

Fitters notes
Filter driers & sight glasses

DCR

Note, there can be overpressure in the filter. Therefore be careful when opening the filter.
 Never re-use the flange gasket in the DCR filter.
 Fit a new gasket and smear it with a little refrigeration machine oil before tightening.



Ah0_0009

Using gaskets

- Only use undamaged gaskets.
- Flange surfaces that are to form the seal must be faultless, clean and dry before mounting.
- Do not use adhesive filler, rust remover or similar chemicals when mounting or dismantling.
- Use sufficient oil for lubricating bolts and screws during mounting.
- Do not use bolts which are dry, corroded or defective in any other way (defective bolts can give incorrect tightening which may result in leaking flange joints).

Mounting gaskets

1. Moisten gasket surfaces with a drop of refrigerant oil.
 2. Put gasket in place.
 3. Mount bolts and tighten slightly until all bolts have made good contact.
 4. Cross-tighten bolts.
- Tighten bolts in at least 3-4 steps, e.g. as follows:
 Step 1: to approx. 10% of required torque.
 Step 2: to approx. 30% of required torque.
 Step 3: to approx. 60% of required torque.
 Step 4: to 100% of required torque.
- Finally, check that the torque is correct in the same order as used when tightening.

Disposal

Always seal used filter driers. They contain small amounts of refrigerant and oil residue.
 Observe authority requirements when scrapping used filter driers.

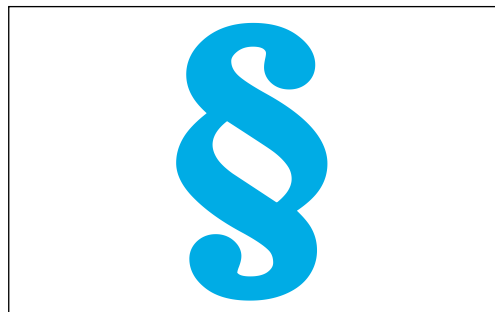

Ah0_0023

Filter drier replacement

- Close valve no. 1.
 - Suck the filter empty.
 - Close valve no. 4.
 - Close valve no. 2.
- The system will now operate, bypassing the filter.
- Replace filter or filter core.
 - Evacuate the filter drier via a schrader valve (no. 3).
 - Restart the system by opening/closing the valves in the reverse order.
 - Remove any levers/handwheels from the valves.

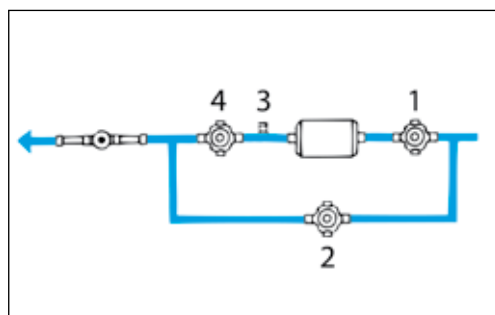

Ah0_0014

Special filters from Danfoss
Combidriers type DCC and DMC

Combidriers type DCC and DMC are used in smaller systems with expansion valve where the condenser cannot contain the entire quantity of refrigerant.

The receiver in the combidrier increases liquid subcooling and creates the possibility of automatic defrost on pumpdown. The receiver takes up varying refrigerant volume (from varying condensing temperature) and must be able to contain the whole refrigerant quantity during service and repair.

In the interests of safety, the volume of the receiver must be at least 15% greater than the refrigerant volume.

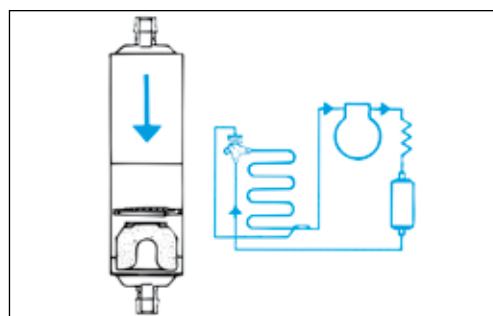

Ah0_0012

Burn-out filter, type 48-DA

Burn-out filter, type 48-DA, is for use after a hermetic or semihermetic compressor has suffered damage.

Compressor damage that gives rise to acid formation will be revealed by oil odour and perhaps discolouration. Damage can occur because of:

- moisture, dirt or air
- defective starter
- refrigerant failure because of too small a refrigerant charge,
- hot gas temperature higher than 175°C

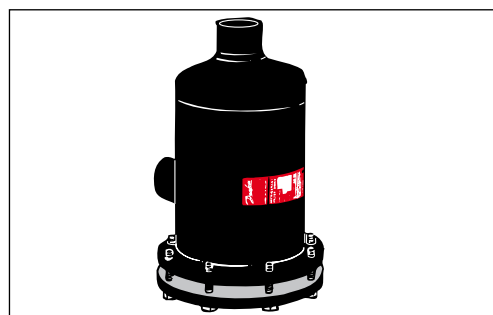

Ah0_0013

After replacing the compressor and cleaning the remainder of the system, two burn-out filters are installed; one in the liquid line and one in the suction line.

The acid content is then checked regularly and the filters replaced as necessary.

When an oil check shows that the system no longer contains acid, the burn-out filter in the liquid line can be replaced by an ordinary filter drier. The burn-out filter core in the suction line can be removed.

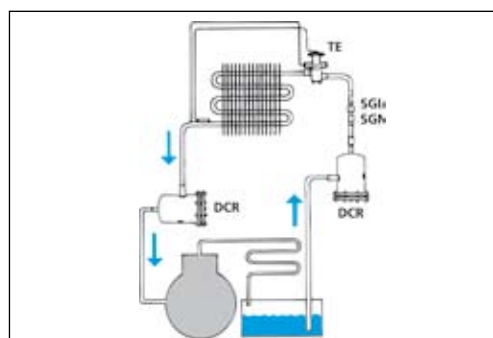

Ah0_0010

Special application
DCL/DML filter driers

Type DCL/DML 032s, DCL/DML 032.5s and DCL/DML 033s are manufactured specially for capillary tube systems and are therefore used in refrigeration systems where expansion is through a capillary tube.

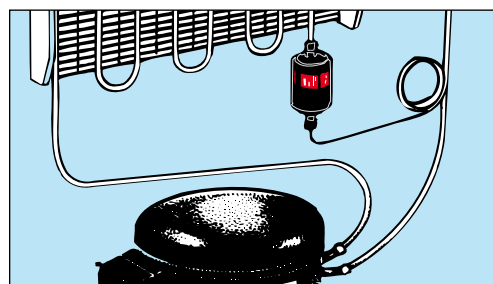

Ah0_0017

DCL/DML filter driers can also be used when repairing refrigerators and freezers, etc. Both time and money can be saved by installing a DCL/DML filter drier in the suction line.

The advantage of doing so can best be illustrated by comparing the normal repair procedure for a defective compressor with a method that exploits the good characteristics of the DCL/DML filter in retaining moisture, acid and dirt.

NOTE: The „DCL/DML method“ can only be used when the oil is not discoloured and when the pencil filter is not clogged.

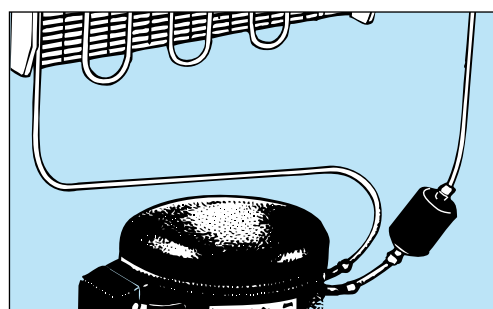

Ah0_0015

Fitters notes
Filter driers & sight glasses
Special application
DCL/DML filter driers (cont.)

The advantages gained by installing a DCL/DML filter in the suction line are:

1. Faster repair.
2. Increased drying and acid capacity.
3. Protection of the compressor against impurities of every kind.
4. Better quality of repair.
5. Cleaner working environment.

The acid and moisture bound in the old oil will be absorbed by the DCL/DML filter.

Therefore it is not necessary to remove remaining oil from the refrigeration system.

Procedure with pencil filter	Procedure with DCL/DML filter
Recover refrigerant and evaluate for re-use	Recover refrigerant and evaluate for re-use
Remove compressor + pencil filter	Remove compressor
Remove oil residue in system	Nothing
Dry system with nitrogen	Nothing
Connect new compressor and fit new pencil filter	Connect new compressor and fit DCL/DML filter in suction line
Evaluate and change refrigerant	Evaluate and change refrigerant

A DCL/DML in the suction line retains impurities from condenser, evaporator, tubing, etc. and thereby prolongs the life of the new compressor.

DCL/DML filters having the same connections as the compressor can be used. The Danfoss range of hermetic compressors can also be recommended.

Example:

Compressor type	Suction tube [mm]	Filter type
TL	Ø6.2	DCL/DML 032s
NL 6-7	Ø6.2	DCL/DML 032s

Dimensioning

When choosing filter driers from catalogues there are several expressions each of which can form the basis of selection.

EPD (Equilibrium Point Dryness)

Defines the least possible water content in a refrigerant in its liquid phase, after it has been in contact with a filter drier.

- EPD for R22 = 60 ppmW *)
- EPD for R410A = 50 ppmW *)
- EPD for R134a = 50 ppmW *)
- EPD for R404A / R507 / R407C = 50 ppmW *)

As stipulated by ARI 710, in ppmW
 $(\text{mg}_{\text{water}} / \text{kg}_{\text{refrigerant}})$

*) ARI: Air-conditioning and Refrigeration Institute, Virginia, USA



Ah0_0025

Drying capacity (water capacity)

The quantity of water the filter drier is able to absorb at 24°C and 52°C liquid temperature, as stipulated by the ARI 710* standard.

The drying capacity is given in grams of water, drops of water or kg refrigerant on drying out.

- R22: 1050 ppmW to 60 ppmW
- R410A: 1050 ppmW to 50 ppmW
- R134a: 1050 ppmW to 50 ppmW
- R404A / R507 / R407C: 1020 ppmW to 50 ppmW
- 1000 ppmW = 1 g water in 1 kg refrigerant 1 g water = 20 drops.

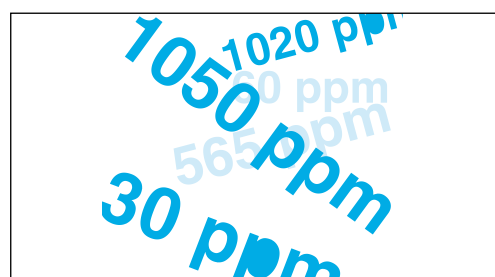

Ah0_0016

Liquid capacity (ARI 710)*

Gives the quantity of liquid able to flow through a filter with a pressure drop of 0.07 bar at $t_c = +30^\circ\text{C}$, $t_e = -15^\circ\text{C}$.

The liquid capacity is stated in l/min or in kW.

Conversion from kW to litres/minute:

- R22 / R410A 1kW = 0.32 l/min
- R134a 1kW = 0.35 l/min
- R404A / R507 / R407C 1kW = 0.52 l/min

*) ARI: Air-conditioning and Refrigeration Institute, Virginia, USA



Ah0_0024

Fitters notes
Filter driers & sight glasses
Recommended system capacity

Stated in kW for different types of refrigeration systems on the basis of a liquid capacity of $\Delta p = 0.14$ bar and typical operating conditions.

Operating conditions:

Refrigeration and freezing systems	$t_e = -15^\circ\text{C}$, $t_c = +30^\circ\text{C}$
A/C systems	$t_e = -5^\circ\text{C}$, $t_c = +45^\circ\text{C}$
A/C units	$t_e = +5^\circ\text{C}$, $t_c = +45^\circ\text{C}$

t_e = evaporating temperature

t_c = condensing temperature

Warning:

With the same system capacity in kW for A/C units and for refrigeration/freezing systems, smaller filter driers can be installed in A/C units because of higher evaporating temperature (t_e) and the assumption that factory produced units contain less moisture than systems built up „on site“.

Filter driers from Danfoss

Product type	Function	Refrigerant	Core	Oil type
DML	Standard filter drier	HFC, compatible with R22	100% molecular sieves	Polyolester (POE) Polyalkyl (PAG)
DCL	Standard filter drier	CFC/HCFC	80% molecular sieves 20% activated alumina	Mineral oil (MO) Alkyl benzene (BE)
DMB	Bi-flow filter drier	HFC, compatible with R22	100% molecular sieves	Polyolester (POE) Polyalkyl (PAG)
DCB	Bi-flow filter drier	CFC/HCFC	80% molecular sieves 20% activated alumina	Mineral oil (MO) Alkyl benzene (BE)
DMC	Combi filter drier	HFC, compatible with R22	100% molecular sieves	Polyolester (POE) Polyalkyl (PAG)
DCC	Combi filter drier	CFC/HCFC	80% molecular sieves 20% activated alumina	Mineral oil (MO) Alkyl benzene (BE)
DAS	Burn-out filter drier	R22, R134a, R404A, R507	30% molecular sieves 70% activated alumina	
DCR	Filter drier with exchangeable core	See core description below	48-DU/DM, 48-DN DC, 48-DA, 48-F	-
48-DU/DM for DCR	Exchangeable core for DCR: std. filter drier	HFC, compatible with R22	100% molecular sieves	Polyolester (POE) Polyalkyl (PAG)
48-DN/DC for DCR	Exchangeable core for DCR: std. filter drier	CFC/HCFC	80% molecular sieves 20% activated alumina	Mineral oil (MO) Alkyl benzene (BE)
48-DA for DCR	Exchangeable core for DCR: std. filter drier	R22, R134a, R404A, R507		
48-F for DCR	Exchangeable core for DCR with exchangeable filter insert	All	-	All