

Data Sheet

Strainer
Type **SFIA**

Easy to install, and ensures quick strainer inspection and cleaning



SFIA strainers are a range of angleway and straightway strainers, which are carefully designed to give favourable flow conditions. The design makes the strainer easy to install, and ensures quick strainer inspection and cleaning.

SFIA strainers are used ahead of automatic controls, pumps, compressors etc., for initial plant start-up and where permanent filtration of the refrigerant is required. The strainer reduces the risk of undesirable system breakdowns and reduces wear and tear on plant components.

SFIA strainers are equipped with a screen of stainless steel, available in sizes 100, 150, 250 and 500 μ (microns).

Features

- Filter net of stainless steel mounted direct without extra gaskets means easy servicing.
- Two types of strainer inserts are available:
 - A plain insert of stainless steel
 - A pleated insert with extra large surface, which ensures long intervals between cleaning and low pressure drop
- SFIA 15-40 (½ – 1 ½ in.): A special insert (50µ) can be used in combination with a standard version when cleaning a plant during commissioning
- SFIA 50-100 (2 - 4 in.): A large capacity filter bag (50µ) can be inserted for cleaning plant during commissioning
- SFIA 80-100 (3 - 4 in.) can be equipped with a magnetic insert for detention of iron particles and other magnetic particles
- Each strainer clearly marked with type, size and performance range

Media

Refrigerants

Applicable to HCFC, HFC and R717 (Ammonia). Flammable hydrocarbons are not recommended. The valve is only recommended for use in closed circuits. For further information please contact Danfoss.

New refrigerants

Danfoss products are continually evaluated for use with new refrigerants depending on market requirements.

When a refrigerant is approved for use by Danfoss, it is added to the relevant portfolio, and the R number of the refrigerant (e.g. R513A) will be added to the technical data of the code number. Therefore, products for specific refrigerants are best checked at store.danfoss.com/en/, or by contacting your local Danfoss representative.

Product specification

Pressure and temperature data

Table 1: Pressure and temperature data

Features	Description
Temperature range	-50 °C/+150 °C (-58 °F/+302 °F)
Max. working pressure	40 bar(g) (580 psig)

Design

Figure 1: Example of marking ring, SFIA

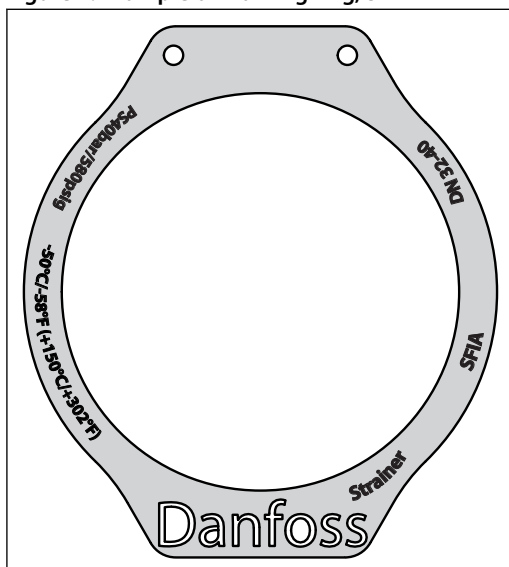

Figure 2: Example of label, SFIA



Strainer Insert

A filter grid and filter net of stainless steel ensure long element life. The filter net offers a very high degree of cleanability.

Installation/Maintenance

The strainer is designed to resist high internal pressures. However, the piping system in general should be designed to avoid liquid traps and reduce the risk of hydraulic pressure caused by thermal expansion. Install the strainer with the cover in downward position.

Danfoss recommends replacement/cleaning of the strainer when the differential pressure loss >0.5 bar (7.3 psi) in the liquid line and >0.05 bar (0.7 psi) in the suction line. The max. permissible differential pressure is 1 bar (15 psi). For further information refer to installation instruction for SFIA.

Selection of strainer size

Definition

Micron specification (μ) of the strainer must satisfy the requirements stated by the suppliers of the equipment to be protected. The following recommendations of aperture size apply in general to refrigeration installations:

All lines

First start up : Plain 50 μ (Use strainer element with removable insert for SFIA DN15-40 or separate filter bag for SFIA DN

50-100. 50 μ inserts should normally be removed after the first 24 hours of operation).

Liquid Lines

Ahead of pumps: 500 μ

After pumps: 150 μ / 250 μ

In front of AKVA valves: 100 μ

Strainer, type SFIA

Protection of automatic regulation equipment

Generally : 150 μ / 250 μ Sensitive equipment
e.g. suction regulators with low temperature : 250 μ

Suction Lines

Ahead of screw compressor : 250 μ

Ahead of piston compressor : 150 μ

Table 2: Flow coefficient (DIN/ANSI)

Connection size (DN)	μ	wire		free space	screen area			
		mm	in.	%	Plain elements		Pleated elements	
					cm ²	in ²	cm ²	in ²
15 - 20 (1/2"-3/4")	50	0.25	0.01	35	25	3.9		
	100	0.068	0.003	35	25	3.9	45	7
	150	0.1	0.004	36	25	3.9	45	7
	250	0.1	0.004	51	25	3.9	45	7
	500	0.16	0.006	57.6	25	3.9	45	7
25 - 40 (1" - 1 1/2")	50	0.16	0.006	38	71	11		
	100	0.068	0.003	35	71	11	160	25
	150	0.1	0.004	36	71	11	160	25
	250	0.1	0.004	51	71	11	160	25
	500	0.16	0.006	57.6	71	11	160	25
50 (2")	50	0.25	0.001	35	87	13.5		
	100	0.068	0.003	35	71	11	200	31.2
	150	0.1	0.004	36	87	13.5	200	31.2
	250	0.1	0.004	51	87	13.5	200	31.2
	500	0.16	0.006	57.6	87	13.5	200	31.2
65 (2 1/2")	50	0.25	0.001	35	127	19.7		
	150	0.1	0.004	36	127	19.7	305	47.6
	250	0.1	0.004	51	127	19.7	305	47.6
	500	0.16	0.006	57.6	127	19.7	305	47.6
80 (3")	50	0.25	0.001	35	205	31.8		
	150	0.1	0.004	36	205	31.8	450	70.2
	250	0.1	0.004	51	205	31.8	450	70.2
	500	0.16	0.006	57.6	205	31.8	450	70.2
100 (4")	50	0.25	0.001	35	370	57.4		
	150	0.1	0.004	36	370	57.4	790	123.2
	250	0.1	0.004	51	370	57.4	790	123.2
	500	0.16	0.006	57.6	370	57.4	790	123.2

Table 3: K_v Values

DN		Plain filter net				Pleated filter net		
		100 μ	150 μ	250 μ	500 μ	150 μ	250 μ	500 μ
DN 15	ANG	3.5	3.5	3.5	5.1	4.6	4.7	
	STR	3.2	3.2	3.4	4.4	4.1	4.1	
DN 20	ANG	7.3	7.5	7.8	7.6	7.0	7.1	
	STR	5.7	6.1	6.1	6.3	6.0	6.1	
DN 25	ANG	8	8.1	8.9	8.3	7.6	7.8	
	STR	5.7	6.1	6.3	6.8	6.4	6.7	
DN 32	ANG	14	15.5	21.9	20	20.4	18.7	
	STR	11.9	11.4	14.0	12.8	13.4	15.8	
DN 40	ANG	18.9	19.9	21.9	25.3	20.1	24.7	
	STR	13.5	15.8	16.3	19.2	15.8	18.8	
DN 50	ANG	38.8	43.3	46.5	50.2	56.7	50.1	62
	STR	28.4	33.4	35.6	38.4	45.9	39.1	50.2
DN 65	ANG		44.4	55.1	60.4	92.2	106	110.4
	STR		53.1	63.1	46.2	85.4	104.2	112.6

Strainer, type SFIA

DN		Plain filter net				Pleated filter net		
		100 μ	150 μ	250 μ	500 μ	150 μ	250 μ	500 μ
DN 80	ANG		104.2	108	113.1	129.2	133.4	139.7
	STR		80	82.6	86.5	107.6	108	113
DN 100	ANG		181.6	194.7	203	187.6	194.2	202.7
	STR		176.1	194.7	195.2	170.6	190.2	194.1

Material specification

Figure 3: SFIA 15-40 (½ in.-1½ in.)

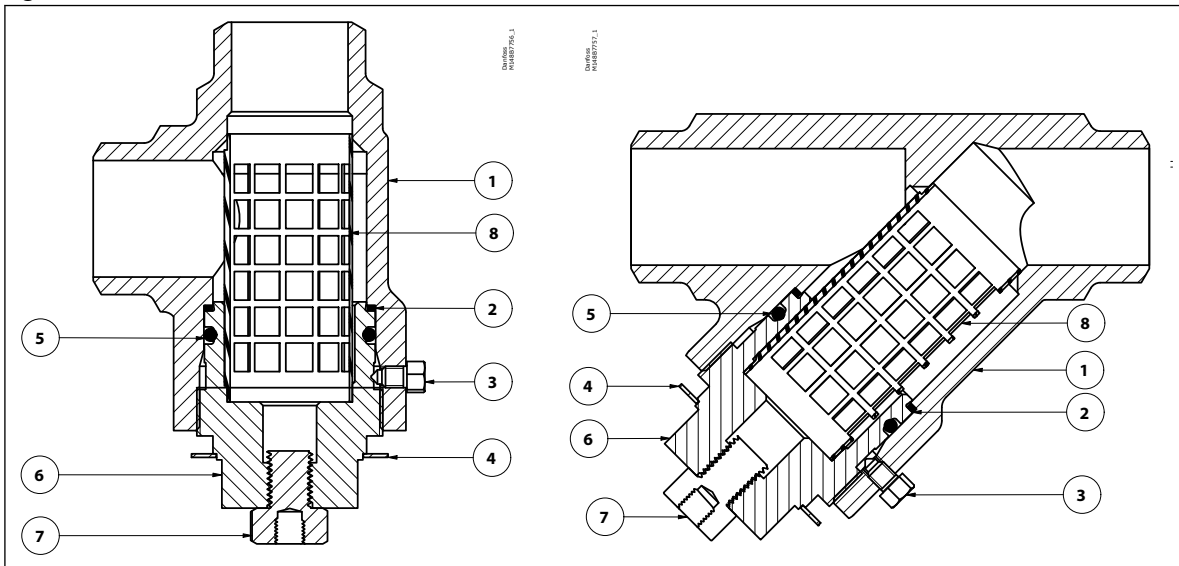
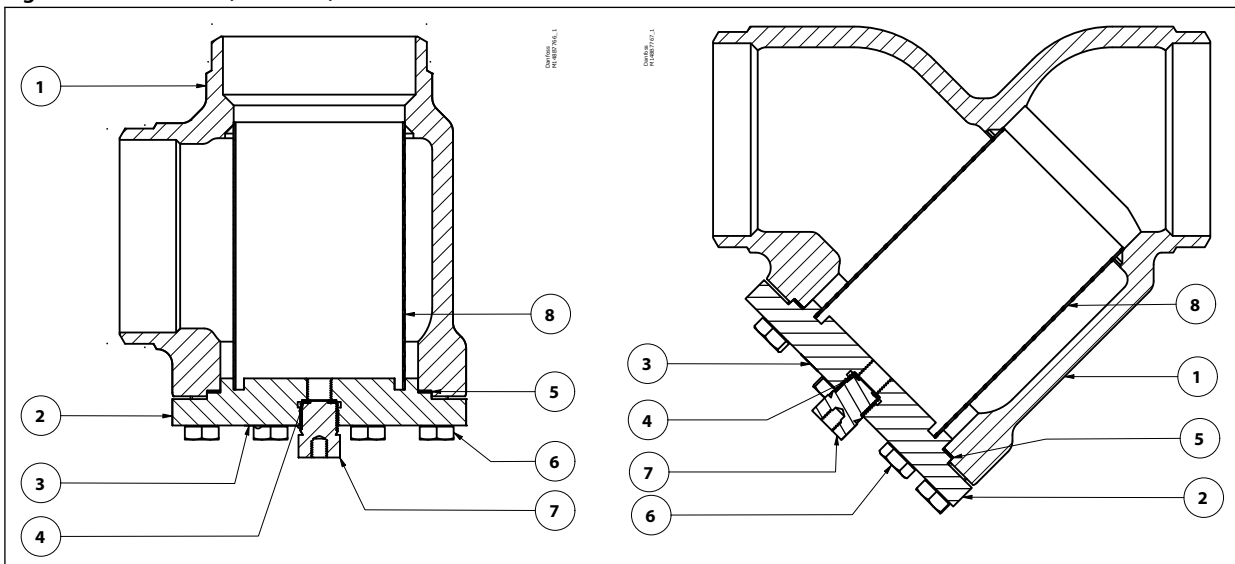

Table 4: SFIA 15-40 (½ in.-1½ in.)

No	Part	Material	DIN	ISO	ASTM
1	Housing	Steel	G20Mn5QT, 10213-3 P285QH+QT, 10222-4		LCC, A352 LF2, A350
2	Gasket	Aluminium			
3	Screw	Stainless steel	A2-70	A2-70	Type 308
4	ID Ring	Aluminium			
5	Gasket	Fiber non asbestos			
6	Bonnet	Steel	QT400-15 GB/T1348	EN-GJS-400-15	
7	Screw G1/2"	Stainless steel			
8	Strainer	Steel			

Figure 4: SFIA 50-100 (2 in.-4 in.)



Strainer, type SFIA

Table 5: SFIA 50-100 (2 in.-4 in.)

No	Part	Material	DIN	ISO	ASTM
1	Housing	Steel	G20Mn5QT, 10213-3 P285QH+QT, 10222-4		LCC, A352 LF2, A350
2	Cover	Steel	P285QH EN10222-4 P275NL1 or EN10028-3		LF2, A350 A, A662
3	ID plate	Aluminium			
4	Gasket	Aluminium			
5	Gasket	Fiber non asbestos			
6	Bolt	Stainless steel	A2-70	A2-70	Type 308
7	Screw G1/2"	Stainless steel			
8	Strainer	Steel			

Connections

Available with the following connections:

- Butt-weld ANSI (B 36.10 Schedule 80):
 - DN 15 - 40 (½ - 1½ in.)
- Butt-weld ANSI (B 36.10 Schedule 40):
 - DN 50 - 100 (2 - 4 in.)

Figure 5: ANSI

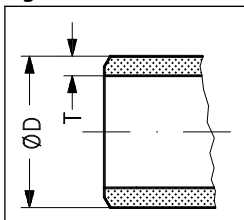

Table 6: Butt-weld ANSI (B 36.10 Schedule 80)

Size		øD	T	øD	T
mm	in.	mm	mm	in.	in.
15	½	21.3	3.7	0.839	0.146
20	¾	26.9	4.0	1.059	0.158
25	1	33.7	4.6	1.327	0.181
32	1¼	42.4	4.9	1.669	0.193
40	1½	48.3	5.1	1.902	0.201

Table 7: Butt-weld ANSI (B 36.10 Schedule 40)

Size		øD	T	øD	T
mm	in.	mm	mm	in.	in.
50	2	60.3	3.9	2.37	0.15
65	2½	73.0	5.2	2.87	0.20
80	3	88.9	5.5	3.50	0.22
100	4	114.3	6.0	4.50	0.24

Dimensions and weights

Table 8: SFIA 15 - 40

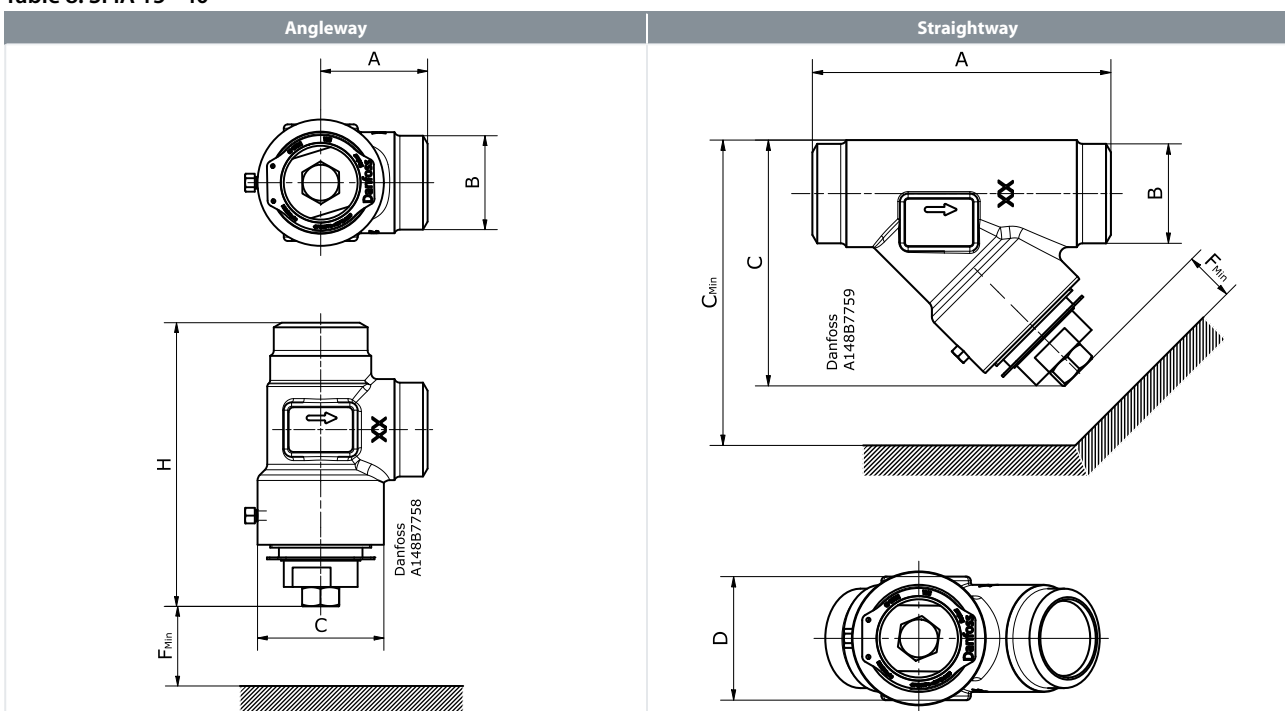

Strainer, type SFIA

Table 9: Angleway

Strainer size		A	B	C	H	F _{Min}	Weight
SFIA 15-25	mm	45	27	49	119	68	0.9 kg
SFIA 1/2" - 3/4"	inch	1.77	1.06	1.92	4.68	2.68	2 lbs
SFIA 32-40	mm	55	48	65	146	95	1.8 kg
SFIA 1 1/4" - 1 1/2"	inch	2.16	1.88	2.55	5.74	3.74	4 lbs

Table 10: Straightway

Strainer size		A	B	C	C _{Min}	D	F _{Min}	Weight
SFIA 15-25	mm	120	27	90	133	44	68	1.2 kg
SFIA 1/2" - 3/4"	inch	4.72	1.06	3.54	5.24	1.73	2.68	2.6 lbs
SFIA 32-40	mm	145	48	119	177	60	95	2.3 kg
SFIA 1 1/4" - 1 1/2"	inch	5.7	1.88	4.68	6.97	2.36	3.74	5.1 lbs

Table 11: SFIA 50 - 100

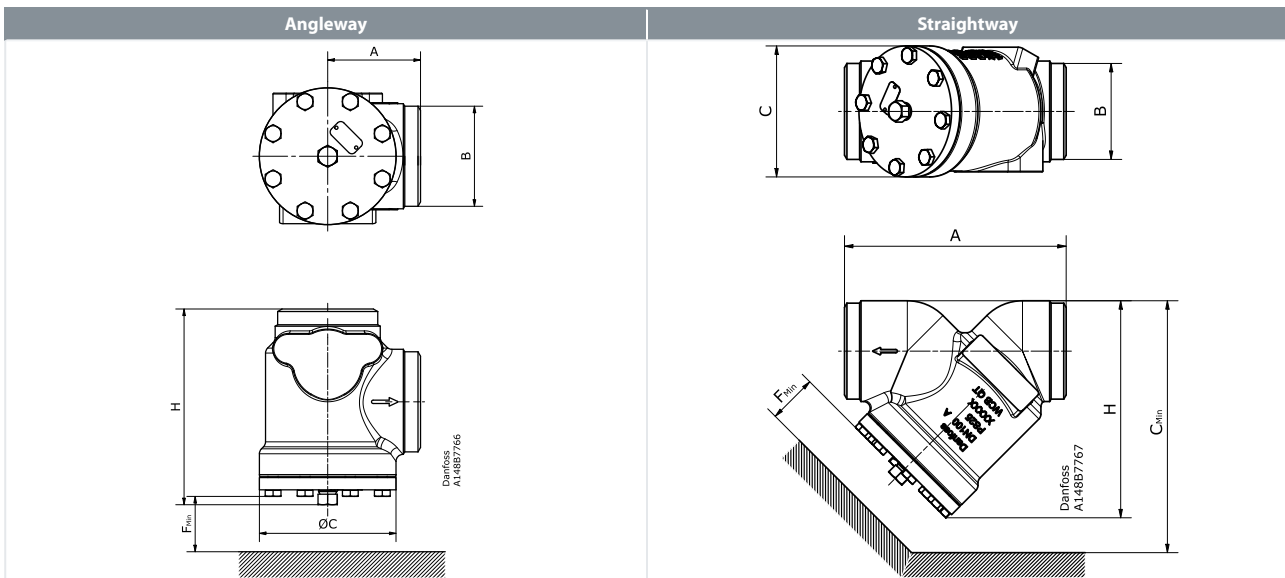

Table 12: Angleway

Strainer size		A	B	C	H	F _{Min}	Weight
SFIA 50	mm	60	60	81	134	92	2.3 kg
SFIA 2"	inch	2.36	2.36	3.18	5.27	3.62	5.1 lbs
SFIA 65	mm	70	73	94	154	107	3.6 kg
SFIA 2 1/2"	inch	2.75	2.87	3.7	6.06	4.21	7.9 lbs
SFIA 80	mm	90	89	129	189	133	7.3 kg
SFIA 3"	inch	3.54	3.5	5.07	7.44	5.34	16.1 lbs
SFIA 100	mm	106	114	156	224	163	12.5 kg
SFIA 4"	inch	4.17	4.48	6.14	8.81	6.42	27.5 lbs

Table 13: Straightway

Strainer size		A	B	C	C _{Min}	H	F _{Min}	Weight
SFIA 50	mm	148	72	80	184	136	92	3 kg
SFIA 2"	inch	5.82	2.83	3.14	7.24	5.35	3.62	6.6 lbs
SFIA 65	mm	176	73	95	219	162	107	5 kg
SFIA 2 1/2"	inch	6.92	2.87	3.74	8.62	6.37	4.21	11 lbs
SFIA 80	mm	216	89	129	271	203	133	9 kg
SFIA 3"	inch	8.5	3.5	5.07	10.67	7.99	5.24	19.8 lbs
SFIA 100	mm	264	114	156	337	259	163	16 kg
SFIA 4"	inch	10.39	4.48	6.14	13.27	10.19	6.42	35.2 lbs

NOTE:

Weight shown in tables 9, 10, 12 and 13 is approximated.

Ordering

The table below is used to identify the strainer required. Please note that you have to order **SFIA strainer without insert, a strainer insert and accessories**.

Example:

SFIA 50 A ANG + SFIA 50 150µ Strainer insert + Filter Bag = **148B7760 + 148H3130 + 148H3150**

- **A** = Butt-weld ANSI
- **ANG** = Angleway
- **STR** = Straightway

Table 14: Butt-weld ANSI(B 36.10 Schedule 80) - Angleway

Size		Type	SFIA with-out strainer insert	Filter insert-plain				Filter insert-pleated		
mm	in.			100µ	150µ	250µ	500µ	150µ	250µ	500µ
15	½	SFIA 15 A ANG	148B7750	148H3122	148H3124	148H3126	148H3128	148H3303	148H3363	-
20	¾	SFIA 20 A ANG	148B7752	148H3122	148H3124	148H3126	148H3128	148H3303	148H3363	-
25	1	SFIA 25 A ANG	148B7754	148H3122	148H3124	148H3126	148H3128	148H3303	148H3363	-
32	1¼	SFIA 32 A ANG	148B7756	148H3123	148H3125	148H3127	148H3129	148H3304	148H3269	-
40	1½	SFIA 40 A ANG	148B7758	148H3123	148H3125	148H3127	148H3129	148H3304	148H3269	-

Table 15: Butt-weld ANSI(B 36.10 Schedule 80) - Straightway

Size		Type	SFIA with-out strainer insert	Filter insert-plain				Filter insert-pleated		
mm	in.			100µ	150µ	250µ	500µ	150µ	250µ	500µ
15	½	SFIA 15 A STR	148B7751	148H3122	148H3124	148H3126	148H3128	148H3303	148H3363	-
20	¾	SFIA 20 A STR	148B7753	148H3122	148H3124	148H3126	148H3128	148H3303	148H3363	-
25	1	SFIA 25 A STR	148B7755	148H3122	148H3124	148H3126	148H3128	148H3303	148H3363	-
32	1¼	SFIA 32 A STR	148B7757	148H3123	148H3125	148H3127	148H3129	148H3304	148H3269	-
40	1½	SFIA 40 A STR	148B7759	148H3123	148H3125	148H3127	148H3129	148H3304	148H3269	-

Table 16: Butt-weld ANSI(B 36.10 Schedule 40) - Angleway

Size		Type	SFIA with-out strainer insert	Filter insert-plain				Filter insert-pleated		
mm	in.			100µ	150µ	250µ	500µ	150µ	250µ	500µ
50	2	SFIA 50 A ANG	148B7760	148H3157	148H3130	148H3138	148H3144	148H3179	148H3184	148H3189
65	2½	SFIA 65 A ANG	148B7762	-	148H3131	148H3139	148H3145	148H3180	148H3185	148H3190
80	3	SFIA 80 A ANG	148B7764	-	148H3119	148H3120	148H3121	148H3181	148H3186	148H3191
100	4	SFIA 100 A ANG	148B7766	-	148H3132	148H3140	148H3146	148H3182	148H3187	148H3192

Table 17: Butt-weld ANSI(B 36.10 Schedule 40) - Straightway

Size		Type	SFIA with-out strainer insert	Filter insert-plain				Filter insert-pleated		
mm	in.			100µ	150µ	250µ	500µ	150µ	250µ	500µ
50	2	SFIA 50 A STR	148B7761	148H3157	148H3130	148H3138	148H3144	148H3179	148H3184	148H3189
65	2½	SFIA 65 A STR	148B7763	-	148H3131	148H3139	148H3145	148H3180	148H3185	148H3190
80	3	SFIA 80 A STR	148B7765	-	148H3119	148H3120	148H3121	148H3181	148H3186	148H3191
100	4	SFIA 100 A STR	148B7767	-	148H3132	148H3140	148H3146	148H3182	148H3187	148H3192

Accessories

Table 18: Accessories

Part	Accessory for	Code number
Magnet insert	SFIA 80-100	148H3447
Strainer insert µ150 with removable insert µ50 for the first start up	SFIA 15-20	148H3301
	SFIA 25-40	148H3302

Strainer, type SFIA

Part	Accessory for	Code number
Filter bag	SFIA 50	148H3150
	SFIA 65	148H3151
	SFIA 80	148H3152
	SFIA 100	148H3153
Purge valve complete	SFIA 50 - 100	148B3745
Blind nut with gasket		148H3450

i NOTE:

Please note that the 50 μ strainer element can be filled up quite fast, so it is recommended to inspect and clean the strainer element at regular intervals based on experience at the installation site.

Certificates, declarations and approvals

The list contains all certificates, declarations, and approvals for this product type. Individual code number may have some or all of these approvals, and certain local approvals may not appear on the list.

Some approvals may change over time. You can check the most current status at danfoss.com or contact your local Danfoss representative if you have any questions.

Table 19: Certificates, declarations and approvals

File name	Document type	Document topic	Approval Authority
MD 033F0691	Manufacturers Declaration	RoHS	Danfoss

Online support

Danfoss offers a wide range of support along with our products, including digital product information, software, mobile apps, and expert guidance. See the possibilities below.

The Danfoss Product Store



The Danfoss Product Store is your one-stop shop for everything product related—no matter where you are in the world or what area of the cooling industry you work in. Get quick access to essential information like product specs, code numbers, technical documentation, certifications, accessories, and more.

Start browsing at store.danfoss.com.

Find technical documentation



Find the technical documentation you need to get your project up and running. Get direct access to our official collection of data sheets, certificates and declarations, manuals and guides, 3D models and drawings, case stories, brochures, and much more.

Start searching now at www.danfoss.com/en/service-and-support/documentation.

Get local information and support



Local Danfoss websites are the main sources for help and information about our company and products. Find product availability, get the latest regional news, or connect with a nearby expert—all in your own language.

Find your local Danfoss website here: www.danfoss.com/en/choose-region.

Danfoss Learning



Danfoss Learning is a free online learning platform. It features courses and materials specifically designed to help engineers, installers, service technicians, and wholesalers better understand the products, applications, industry topics, and trends that will help you do your job better.

Create your Danfoss Learning account for free at www.danfoss.com/en/service-and-support/learning.

Spare Parts



Get access to the Danfoss spare parts and service kit catalog right from your smartphone. The app contains a wide range of components for air conditioning and refrigeration applications, such as valves, strainers, pressure switches, and sensors.

Download the Spare Parts app for free at www.danfoss.com/en/service-and-support/downloads.

Coolselector®2 - find the best components for you HVAC/R system



Coolselector®2 makes it easy for engineers, consultants, and designers to find and order the best components for refrigeration and air conditioning systems. Run calculations based on your operating conditions and then choose the best setup for your system design.

Download Coolselector®2 for free at coolselector.danfoss.com.

Danfoss A/S

Climate Solutions • danfoss.com • +45 7488 2222

Any information, including, but not limited to information on selection of product, its application or use, product design, weight, dimensions, capacity or any other technical data in product manuals, catalogues descriptions, advertisements, etc. and whether made available in writing, orally, electronically, online or via download, shall be considered informative, and is only binding if and to the extent, explicit reference is made in a quotation or order confirmation. Danfoss cannot accept any responsibility for possible errors in catalogues, brochures, videos and other material. Danfoss reserves the right to alter its products without notice. This also applies to products ordered but not delivered provided that such alterations can be made without changes to form, fit or function of the product.

All trademarks in this material are property of Danfoss A/S or Danfoss group companies. Danfoss and the Danfoss logo are trademarks of Danfoss A/S. All rights reserved.