

ENGINEERING
TOMORROW

Danfoss

Design Guide

Controller for evaporator control

AK-CC 750 - 080Z0130 & 080Z0139

ADAP-KOOL® Refrigeration control systems

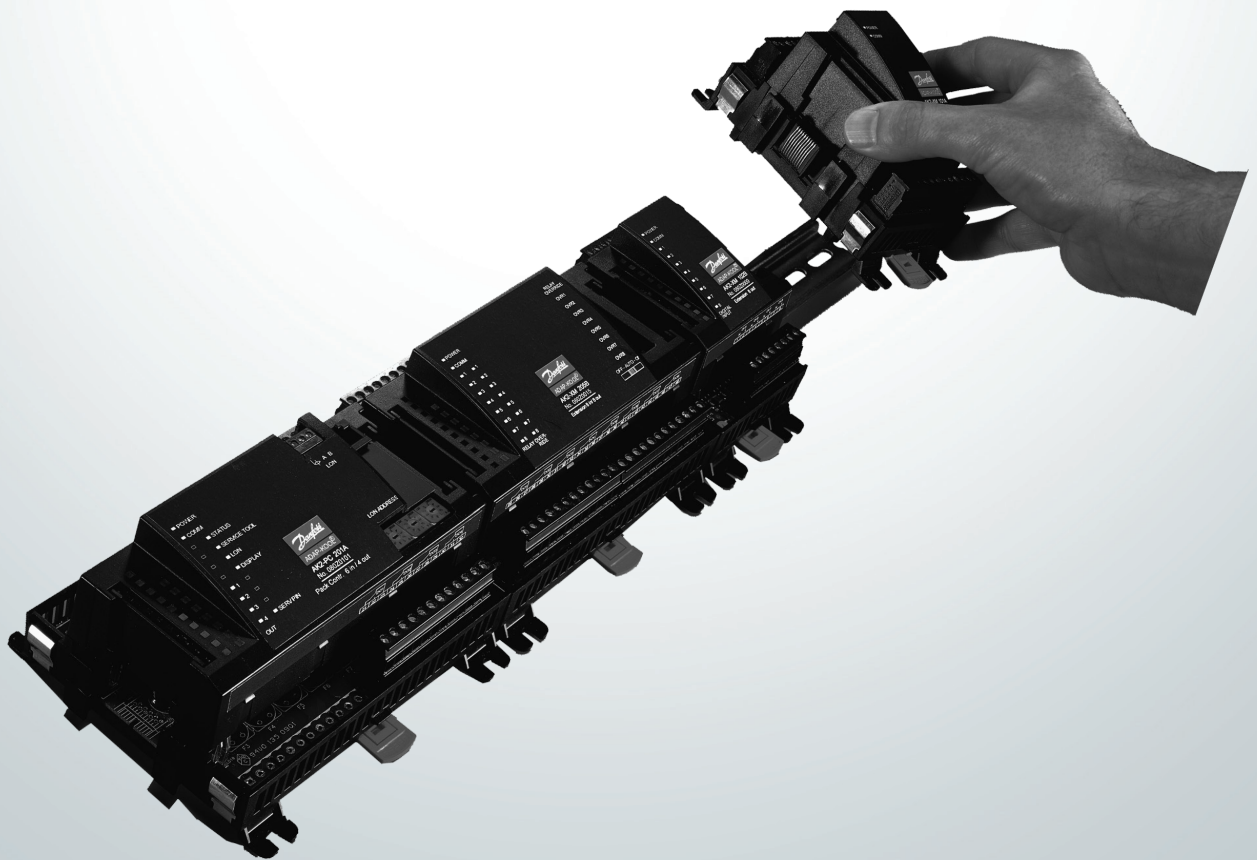

Contents

1. Introduction	3	4. Configuration and operation	41
Application.....	3	Configuration.....	43
Principles.....	4	Connect PC.....	43
2. Design of a controller	7	Authorization.....	44
Module survey.....	8	Unlock the configuration of the controllers.....	45
Common data for modules.....	10	System setup.....	46
Controller.....	12	Set plant type.....	47
Extension module AK-XM 101A.....	14	Definition of thermostat.....	48
Extension module AK-XM 102A / AK-XM 102B.....	16	Definition of sections.....	49
Extension module AK-XM 204A / AK-XM 204B.....	18	Definition of defrost functions.....	50
Extension module AK-XM 205A / AK-XM 205B.....	20	Definition of common functions.....	51
Extension module AK-OB 101A.....	22	Configuration of inputs and outputs.....	53
Display module EKA 163B / EKA 164B.....	23	Set alarm priorities.....	55
Transformer module AK-PS 075 / 150.....	24	Lock configuration.....	57
Case Power module.....	25	Check configuration.....	58
Preface to design.....	26	Check of connections.....	59
Functions.....	26	Check of settings.....	60
Connections.....	27	Installation in network.....	63
Limitations.....	27	First start of control.....	64
Design of a evaporator control.....	28	Start the control.....	65
Procedure:.....	28	Setup logs.....	66
Sketch.....	28	Manual defrost.....	67
Evaporator and refrigerator appliance functions.....	28	5. Regulating functions	69
Connections.....	30	Introduction.....	70
Planning table.....	31	Thermostat function.....	71
Length.....	32	Temperature alarms.....	75
Linking of modules.....	32	Common functions.....	76
Determine the connection points.....	33	Liquid injection.....	78
Connection diagram.....	34	Defrost.....	79
Supply voltage.....	35	Miscellaneous.....	84
Ordering.....	36	Information.....	86
3. Mounting and wiring	37	Alarm texts.....	88
Mounting.....	38	Appendix - Recommended connection.....	90
Mounting of extension module on the basic module.....	38		
Wiring.....	39		

Info

AK-CC 750 - 080Z0130 and 080Z0139 are US-versions of the standard AK-CC 750 controller.

Main changes:

- Temperature in °F
- Pressure in PSI
- Other quick setup
- Separate controls are removed
- No stepper valve connections
- 080Z0130 = LON TP 78
- 080Z0139 = LON RS 485

Software:

080Z0130: 6.0x

084Z0139: 6.1x

1. Introduction

Application

AK-CC 750 controllers are complete regulating units which together with valves and sensors constitute complete evaporator controls for refrigeration appliances and freezing rooms within commercial refrigeration.

Generally speaking they replace all other automatic controls containing, inter alia, day and night thermostats, defrost, fan control, rail heat control, alarm functions, light control, thermo valve control, solenoid valve, etc.

The controller is equipped with data communication and is operated via a PC.

In addition to evaporator control the controller can give signals to other controllers about the operating condition, e.g. forced closing of expansion valves, alarm signals and alarm messages.

Advantages

- Control of 1 to 4 evaporator sections
- Adaptive superheat control ensures optimum evaporator usage in all operational circumstances.
- Electronic injection with AKV valve
- Traditional temperature regulation using on/off or modulating control of solenoid valve for both DX and indirect brine system.
- Weighted thermostat and alarm thermostat
- Defrost on demand based on evaporator capacity
- Appliance cleaning function
- Light control using door switch or network signal depending on day/night operation
- Rail heat pulsing depending on day/night operation or dew point
- Monitoring of door alarm and control of light/refrigeration depending on location of door switch.
- Log function for registration of historical parameter values and alarm modes.

Control

The controller's main function is to control the evaporator so that the system constantly operates with the most energy-friendly refrigeration.

A specific function for registration of the need for defrost will adapt the number of defrosts so that no energy is wasted on unnecessary defrosts and subsequent cooling-down cycles.

Adaptive defrosting

The AK-CC 750 includes an adaptive defrosting function. By using the AKV valve as mass flow sensor for the supply of refrigerant, the controller can monitor ice formation on the evaporator. If the load is too large for the standard defrost programme, the controller initiates additional automatic defrost cycles to eliminate the need for expensive service calls due to iced-up evaporators.

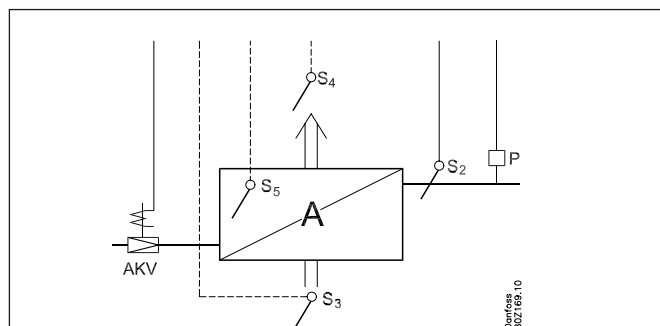
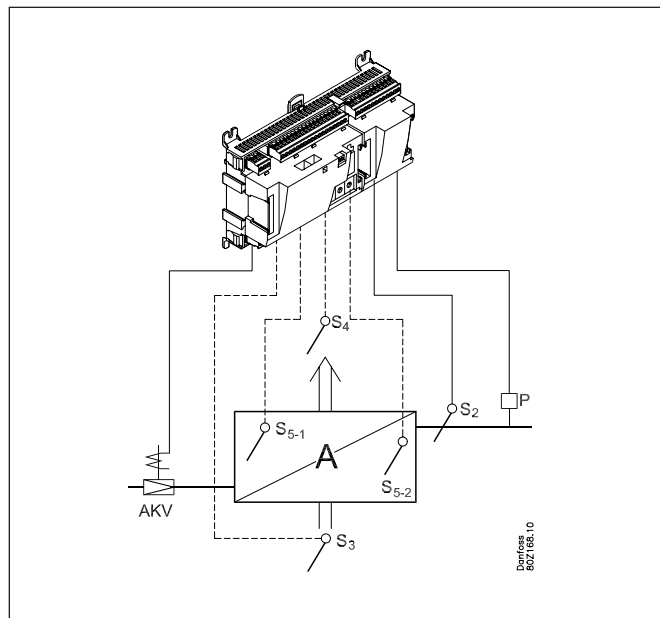

Evaporator control of one, two, three or four evaporators

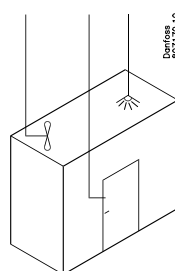

Control of cool or frost room

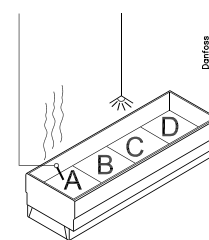

Control of cool or frost appliance

Principles

The great advantage of this series of controllers is that it can be extended as the size of the plant is increased. It has been developed for refrigeration control systems, but not for any specific application – variation is created through the read-in software and the way you choose to define the connections. It is the same modules that are used for each regulation and the composition can be changed, as required. With these modules (building blocks) it is possible to create a multitude of various kinds of regulations. But it is you who must help adjusting the regulation to the actual needs – these instructions will assist you to find your way through all the open questions so that the regulation can be defined and the connections made.

Advantages

- The controller's size can "grow" as systems grow
- The software can be set for one or more regulations
- Several regulations with the same components
- Extension-friendly when systems requirements are changed
- Flexible concept:
 - Controller series with common construction
 - One principle – many regulation uses
 - Modules are selected for the actual connection requirements
 - The same modules are used from regulation to regulation

Controller

Danfoss
80Z92.1.1

Top part

Bottom part

Extension modules

Danfoss
AB0Z93.1.0

The controller is the cornerstone of the regulation. The module has inputs and outputs capable of handling small systems.

- The bottom part – and hence the terminals – are the same for all controller types.
- The top part is the intelligence with software. This unit will vary according to controller type. But it will always be supplied together with the bottom part.
- In addition to the software the top part is provided with connection for data communication and address setting.

If the system grows and more functions have to be controlled, the regulation can be extended. With extra modules more signals can be received and more relays cut in and out – how many of them – and which – is determined by the relevant application.

Examples

Danfoss
AB0Z93.1.0

A regulation with few connections can be performed with the controller module alone

Danfoss
AB0Z94-1.0

If there are many connections one or more extension modules have to be mounted

Direct connection

Setup and operation of an AK controller must be accomplished via the "AK-Service Tool" software program.

The programme is installed on a PC, and setup and operation of the various functions are carried out via the controller's menu displays.

Displays

The menu displays are dynamic, so that different settings in one menu will result in different setting possibilities in other menus.

A simple application with few connections will give a setup with few settings.

A corresponding application with many connections will give a setup with many settings.

From the overview display there is access to further displays for the regulation.

At the bottom of the display there is access to a number of general functions, such as "time table", "manual operation", "log function", "alarms", and "service" (configuration).

Network linking

The controller can be linked up into a network together with other controllers in an ADAP-KOOL® refrigeration control system. AK-SC 255, 355 or SM850 can be used as a system unit. After initial setup, operation can be performed from control system.

080Z0130 is equipped with LON TP 78

080Z0139 is equipped with LON RS 485.

Users

The controller comes supplied with several languages, one of which can be selected and employed by the user. If there are several users, they may each have their choice of language. All users must be assigned a user profile which either gives access to full operation or gradually limits the operation to the lowest level that only allows you "to see".

External display

An external display can be fitted in order for P0 (Suction) and Pc (Condensing) readings to be displayed.

In AK-CC 750 up to 4 displays can be mounted.

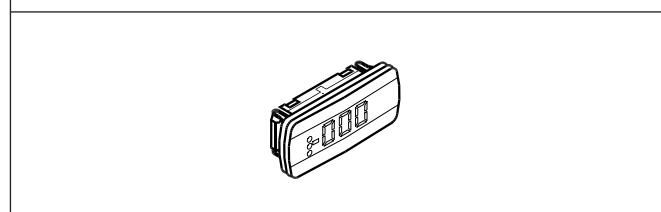
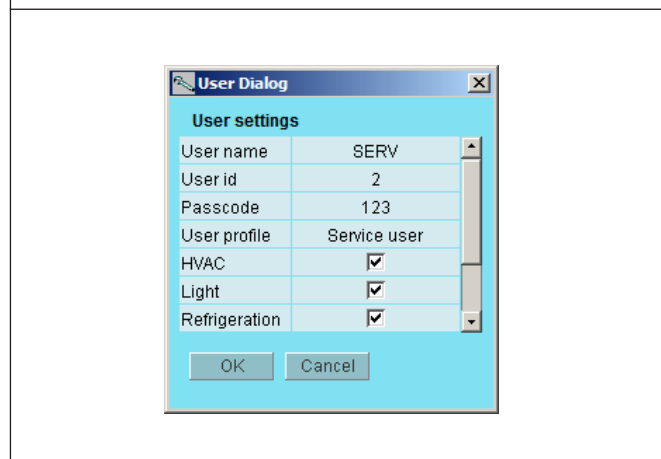
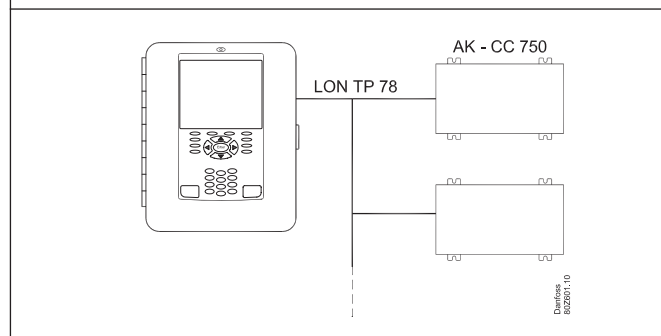
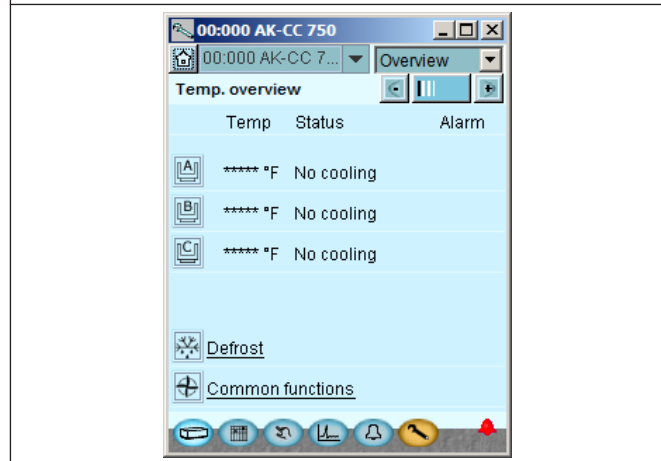
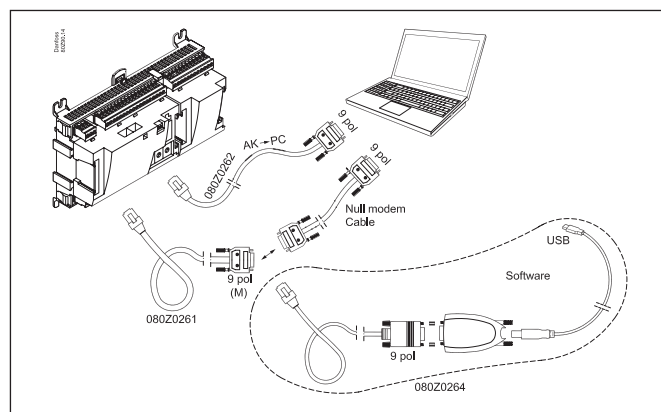

Light-emitting diodes

A number of light-emitting diodes makes it possible to follow the signals that are received and transmitted by the controller.

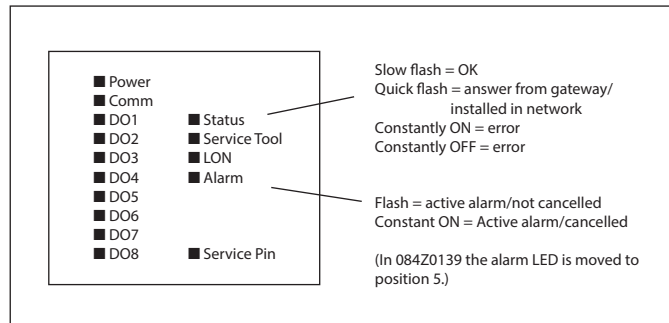

Log

From the log function you can define the measurements you wish to be shown.

The collected values can be printed, or you may export them to a file. You can open the file in Excel or import in AKM.

(The Log function is only available via AK-ST 500.)

If you are in a service situation you can show measurements in a trend function. The measurements are then made real-time and displayed instantly.

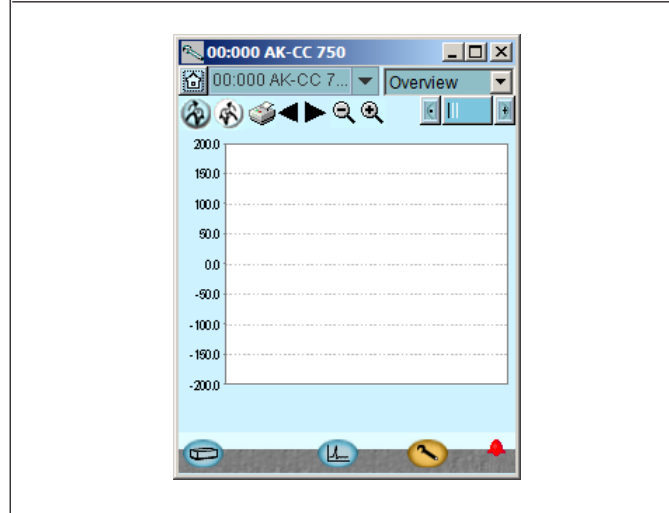

Alarm

The display gives you an overview of all active alarms. If you wish to confirm that you have seen the alarm you can cross it off in the acknowledge field.

If you want to know more about a current alarm you can click on it and obtain an information display on the screen.

A corresponding display exists for all earlier alarms. Here you can upload information if you need further details about the alarm history.

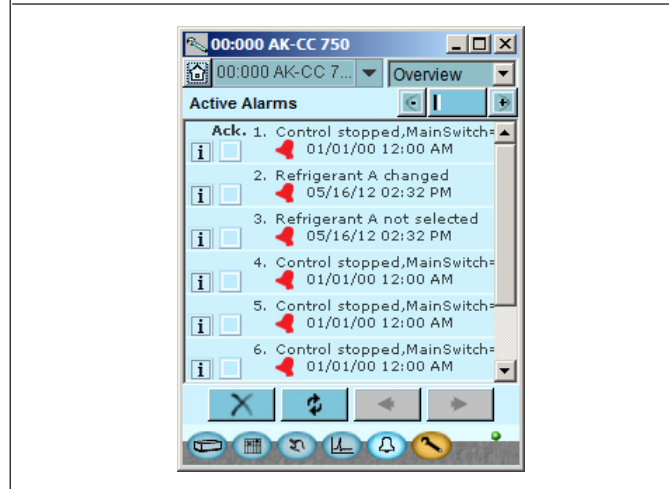

Adaptive defrost

AK-CC 750 is equipped with an adaptive defrost function. By using an AKV valve as mass flow sensor for the supply of refrigerant the control can monitor ice formation on the evaporator.

Function can cancel planned defrosts which are not necessary, and on its own initiative start a defrost if the evaporator is about to be blocked by rime and ice.

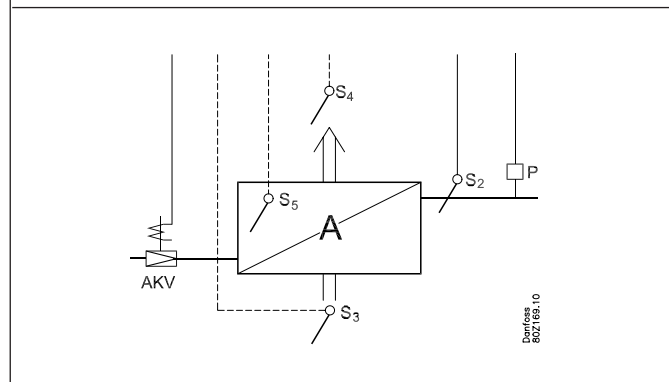

2. Design of a controller

This section describes how the controller is designed.

The controller in the system is based on a uniform connection platform where any deviations from regulation to regulation is determined by the used top part with a specific software and by which input and output signals the relevant application will require. If it is an application with few connections, the controller module (top part with belonging bottom part) may be sufficient. If it is an application with many connections it will be necessary to use the controller module plus one or more extension modules.

This section will give you a survey of possible connections plus assistance in selecting the modules required by your actual application.

Module survey

- Controller module – capable of handling minor plant requirements.
- Extension modules. When the numbers of evaporators becomes greater and additional inputs or outputs are required, modules can be attached to the controller. A plug on the side of the module will transmit the supply voltage and data communication between the modules.
- Top part
The upper part of the controller module contains the intelligence. This is the unit where the regulation is defined and where data communication is connected to other controllers in a bigger network.
- Connection types
There are various types of inputs and outputs. One type may, for example, receive signals from sensors and switches, another may receive a voltage signal, and a third type may be outputs with relays etc. The individual types are shown in the table below.
- Optional connection
When a regulation is planned (set up) it will generate a need for a number of connections distributed on the mentioned types. This connection must then be made on either the controller module or an extension module. The only thing to be observed is that the types must not be mixed (an analog input signal must for instance not be connected to a digital input).
- Programming of connections
The controller must know where you connect the individual input and output signals. This takes place in a later configuration where each individual connection is defined based on the following principle:
 - to which module
 - at which point ("terminals")
 - what is connected (e.g. pressure transmitter/type/pressure range)

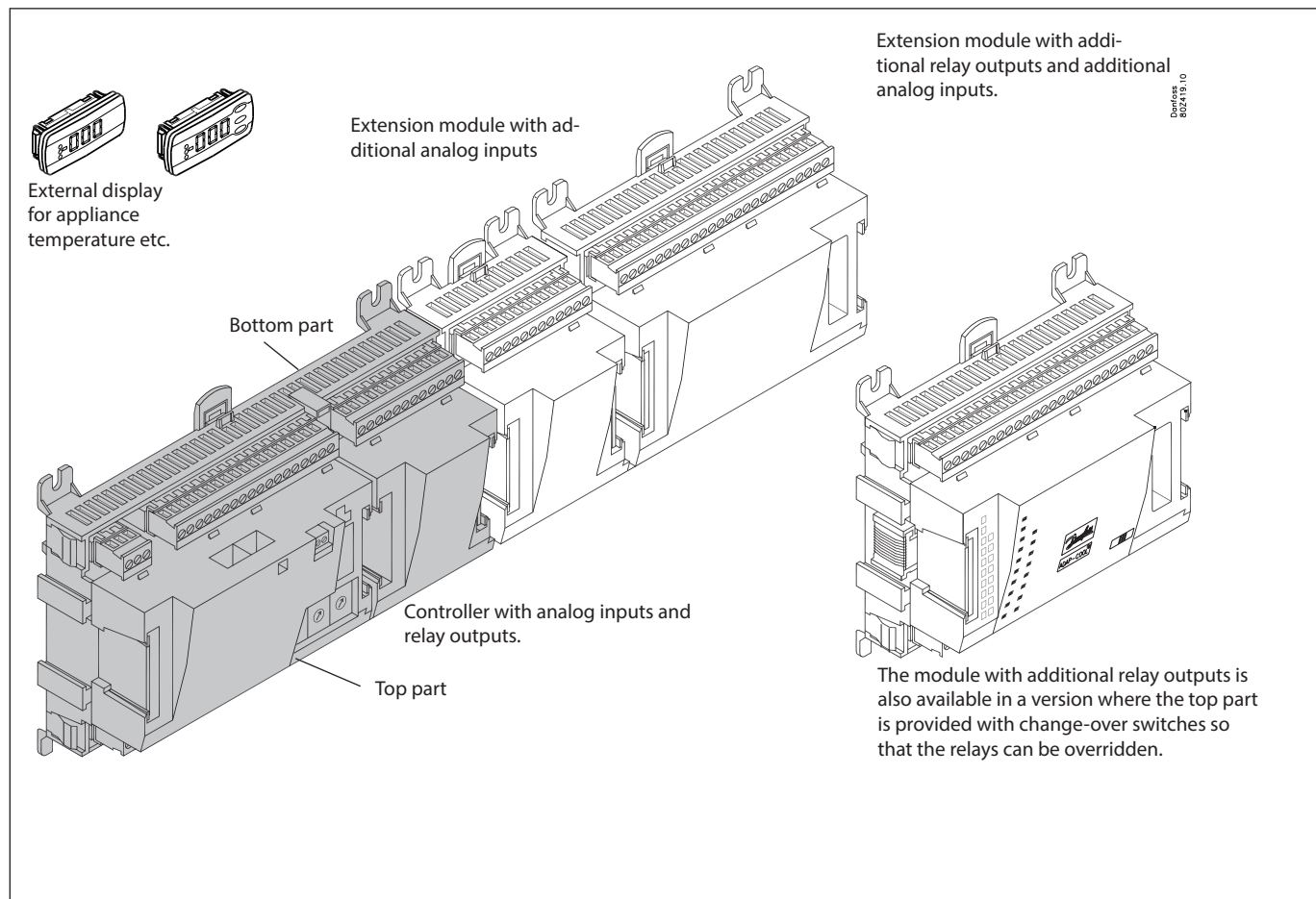

1. Controller

Type	Function	Application
AK-CC 750	Controller for evaporator control	Refrigeration appliances control

2. Extension modules and survey of inputs and outputs

Type	Analog inputs	On/Off outputs		On/off supply voltage (DI signal)		Module with switches
	For sensors, pressure transmitters etc.	Relay (SPDT)	Solid state	Low voltage (max. 80 V)	High voltage (max. 260 V)	For override of relay outputs
Controller	11	4	4	-	-	-
Extension modules						
AK-XM 101A	8					
AK-XM 102A				8		
AK-XM 102B					8	
AK-XM 204A		8				
AK-XM 204B		8				x
AK-XM 205A	8	8				
AK-XM 205B	8	8				x

3. AK operation and accessories

Type	Function	Application
Operation		
AK-ST 500	Software for operation of AK controllers	AK-operation
-	Cable between PC and AK controller	AK - Com port
-	Cable between zero modem cable and AK controller / Cable between PDA cable and AK controller	AK - RS 232
-	Cable between PC and AK controller	AK - USB
Accessories		
Transformer module 230 V / 115 V to 24 V		
AK-PS 075	18 VA, 24 V d.c.	Supply for controller
AK-PS 150	36 VA, 24 V d.c.	
Accessories		
External display that can be connected to the controller module. For showing, say, the refrigeration appliances		
EKA 163B	Display	
EKA 164B	Display with operation buttons	
-	Cable between display and controller	Length = 6.5 ft Length = 19.5 ft
Accessories		
Real time clock for use in controllers that require a clock function, but are not wired with data communication.		
AK-OB 101A	Real time clock with battery backup.	To be mounted in an AK controller

On the following pages there is data specific to each module.

Common data for modules

Supply voltage	24 V d.c. / a.c. +/- 20%	
Power consumption	AK-__ (controller)	8 VA
	AK-XM 101, 102, 103	2 VA
	AK-XM 204, 205	5 VA
Analog inputs	Pt 1000 ohm /0°C	Resolution: 0.1°C Accuracy: +/- 0.5°C (between -58°F and +122°F)
	PTC 1000 ohm /0°C	
	Pressure transmitter type AKS 32R / AKS 2050 / AKS 32 (1-5 V)	Resolution: 1 mV Accuracy +/- 10 mV Max. connection of 5 pressure transmitters on one module
	Voltage signal 0-10 V	
	Contact function (On/Off)	On at R < 20 ohm Off at R > 2K ohm (Gold -plated contacts not necessary)
On/off supply voltage inputs	Low voltage 0 / 80 V a.c./d.c.	Off: U < 2 V On: U > 10 V
	High voltage 0 / 260 V a.c.	Off: U < 24 V On: U > 80 V
Relay outputs SPDT	AC-1 (ohmic)	4 A
	AC-15 (inductive)	3 A
	U	Min. 24 V Max. 230 V Low and high voltage must not be connected to the same output group
Solid state outputs	Can be used for loads that are cut in and out frequently, e.g. : rail heat, fans and AKV valve	Max. 240 V a.c. , Min. 48 V a.c. Max. 0.5 A, Leak < 1 mA Max. 1 AKV
Ambient temperature	During transport	-40 to 158°F
	During operation	-4 to 131°F , 0 to 95% RH (non condensing) No shock influences / vibrations
Enclosure	Material	PC / ABS
	Density	IP10 , VBG 4
	Mounting	For mounting on panel wall or DIN rail
Weight with screw terminals	modules in 100- / 200- / controller-series	Ca. 7 oz / 17 oz / 21 oz
Approvals	EU low voltage directive and EMC requirements are complied with	LVD tested according to EN 60730 EMC tested Immunity according to EN 61000-6-2 Emission according to EN 61000-6-3
	UL 873,  us	UL file number: E166834

The mentioned data applies to all modules.
If data is specific, this is mentioned together with the module in question.

Dimensions

The module dimension is 72 mm (2.83 in).

Modules in the 100-series consist of one module

Modules in the 200-series consist of two modules

Controllers consist of three modules

The length of an aggregate unit = $n \times 72 + 8 \text{ mm}$ ($n \times 2.83 + 0.32 \text{ in}$).

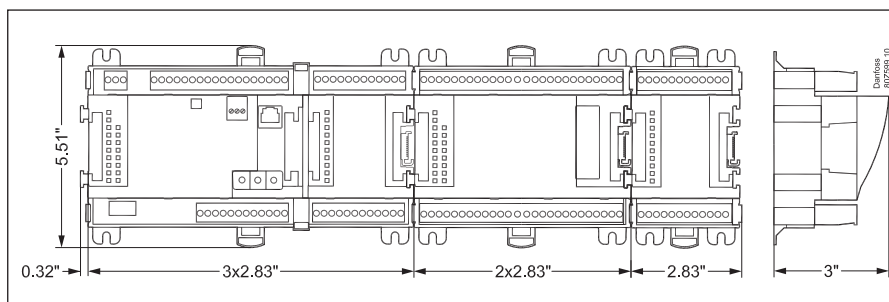

Controller

Function

There are several controllers in the series. The function is determined by the programmed software, but outwardly the controllers are identical – they all have the same connection possibilities: 11 analog inputs for sensors, pressure transmitters, voltage signals and contact signals.
8 digital outputs, with 4 Solid state outputs and 4 relay outputs

Supply voltage

24 V a.c. or d.c. to be connected to the controller.
The 24 V must **not** be retransmitted and used by other controllers as it is not galvanically separated from inputs and outputs. In other words, you **must** use a transformer for each controller. Class II is required. The terminals must **not** be earthed.
The supply voltage to any extension modules is transmitted via the plug on the right-hand side.
The size of the transformer is determined by the power requirement of the total number of modules.

The supply voltage to a pressure transmitter can be taken either from the 5 V output or from the 12 V output depending on transmitter type.

Data communication

If the controller is to be included in a system, communication must take place via the LON connection.
The installation has to be made as mentioned in the separate instructions for LON communication.

Address setting

When the controller is connected to a system unit, the controller's address must be set between 1 and 200.

Scan function

When the controller is connected to the data communication cable the system unit must have knowledge of the new controller. This is obtained by the scan function in the system unit. The LED "Status" will flash fast when the system unit sends an acceptance message.

Operation

The configuration operation of the controller must take place from the software programme "Service Tool". The program must be installed on a PC, and the PC must be connected to the controller via the network plug on the front of the unit.

Light-emitting diodes

There are two rows with LED's. They mean:

Left row:

- Voltage supply to the controller
- Communication active with the bottom PC board (red = error)
- Status of outputs DO1 to DO8

Right row:

- Software status (slow flash = OK)
- Communication with Service Tool
- Communication on LON
- Alarm when LED flashes
- 3 LED's that are not used
- "Service Pin" switch has been activated

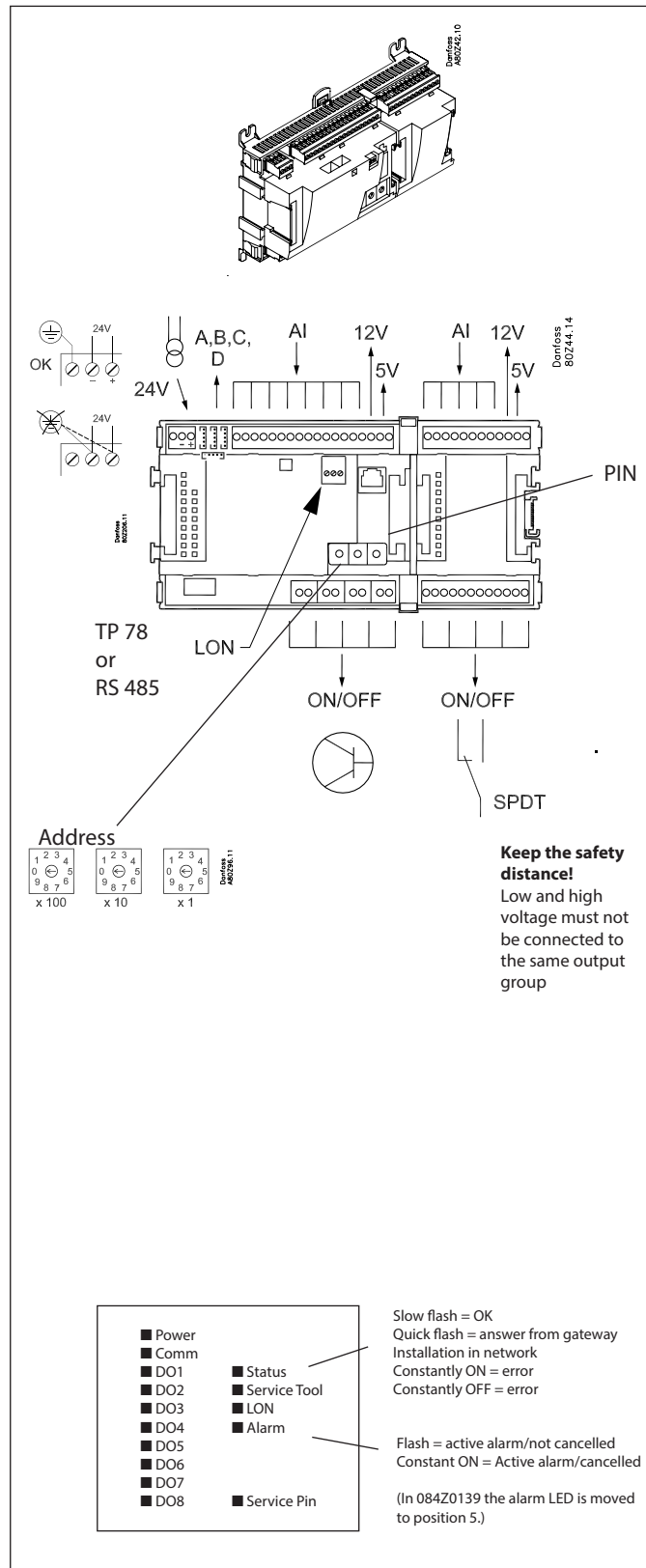

Point

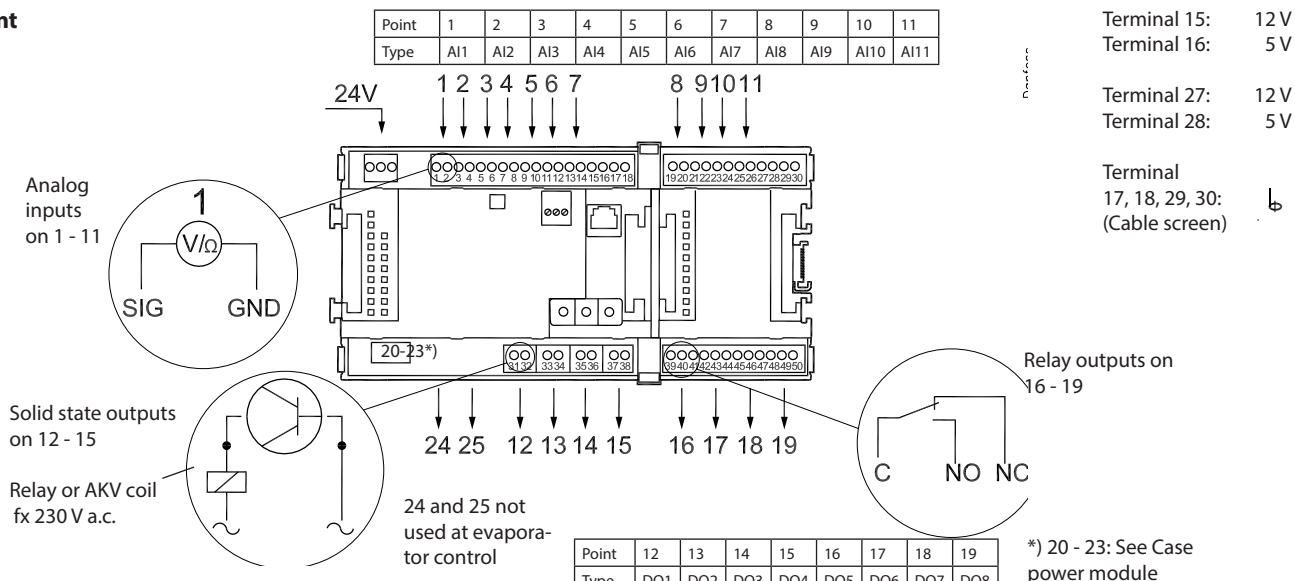

	Signal	Signal type
S Pt 1000 ohm/0°C	SIG GND	S2, S3, S4, S5 Pt 1000 Saux
P AKS 32R AKS 2050 AKS 32	3: Brown SIG 2: Blue GND 1: Black 5V 3: Brown SIG 2: Black GND 1: Red 12V	P0 Pc Paux AKS 32R AKS 2050 -1 - xx bar AKS 32 -1 - zz bar
U	+ SIG - GND	0 - 5V 0 - 10V
On/Off	SIG GND	Ext. Main switch Day/Night Door Defrost Active at: Closed / Open
DO	AKV C NO NC	AKV Fan Alarm Light Rail heat Defrost Night blind Valves Compressor Active at: On / Off

Signal	Module	Point	Terminal	Signal type / Active at
	1	1 (AI 1)	1 - 2	
		2 (AI 2)	3 - 4	
		3 (AI 3)	5 - 6	
		4 (AI 4)	7 - 8	
		5 (AI 5)	9 - 10	
		6 (AI 6)	11 - 12	
		7 (AI 7)	13 - 14	
		8 (AI 8)	19 - 20	
		9 (AI 9)	21 - 22	
		10 (AI 10)	23 - 24	
		11 (AI 11)	25 - 26	
		12 (DO 1)	31 - 32	
		13 (DO 2)	33 - 34	
		14 (DO 3)	35 - 36	
		15 (DO 4)	37 - 38	
		16 (DO 5)	39 - 40 - 41	
		17 (DO 6)	42 - 43 - 44	
		18 (DO 7)	45 - 46 - 47	
		19 (DO 8)	48 - 49 - 50	

Extension module AK-XM 101A

Function

The module contains 8 analog inputs for sensors, pressure transmitters, voltage signals and contact signals.

Supply voltage

The supply voltage to the module comes from the previous module in the row.

Supply voltage to a pressure transmitter can be taken from either the 5 V output or the 12 V output depending on transmitter type.

Light-emitting diodes

Only the two top LED's are used. They indicate the following:

- Voltage supply to the module
- Communication with the controller is active (red = error)

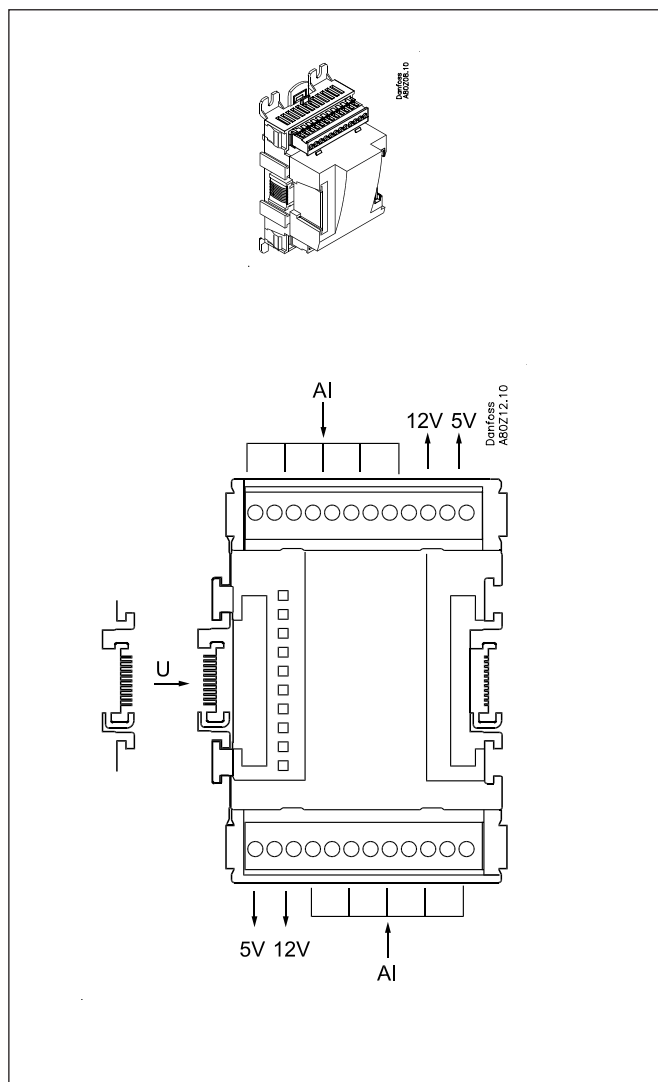

Point

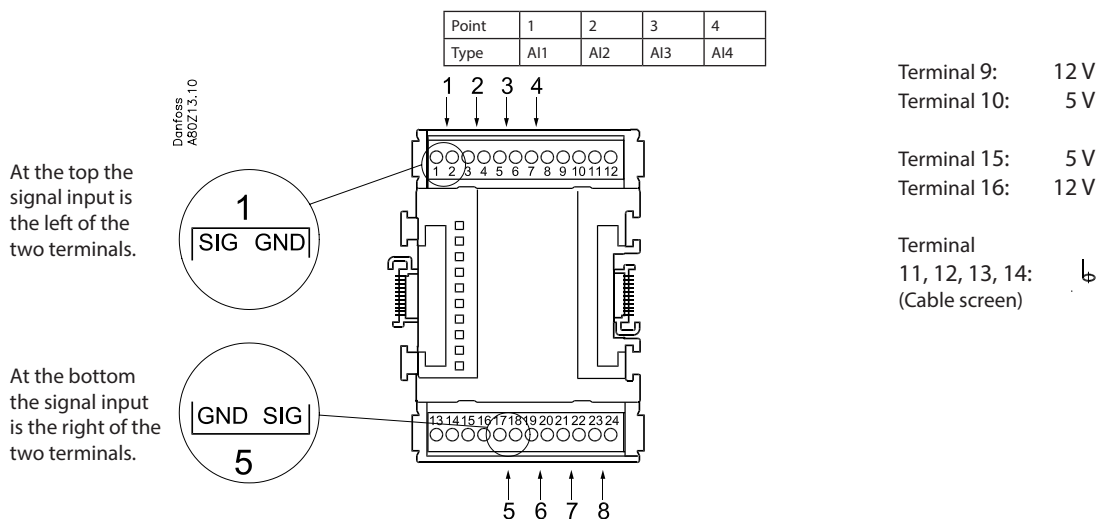

	Signal	Signal type
S Pt 1000 ohm/0°C 	S2 S3 S4 S5 Saux	Pt 1000
P AKS 32R AKS 2050 AKS 32 	P0 Pc Paux	AKS 32R AKS 2050 -1 - xx bar AKS 32 -1 - zz bar
U 	...	0 - 5 V 0 - 10 V
On/Off 	Ext. Main switch Day/ Night Door Defrost	Active at: Closed / Open

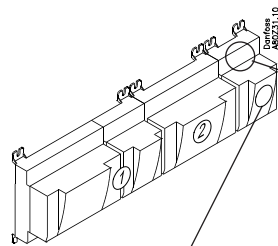

Signal	Module	Point	Terminal	Signal type / Active at
		1 (AI 1)	1 - 2	
		2 (AI 2)	3 - 4	
		3 (AI 3)	5 - 6	
		4 (AI 4)	7 - 8	
		5 (AI 5)	17 - 18	
		6 (AI 6)	19 - 20	
		7 (AI 7)	21 - 22	
		8 (AI 8)	23 - 24	

Extension module AK-XM 102A / AK-XM 102B

Function

The module contains 8 inputs for on/off voltage signals.

Signal

AK-XM 102A is for low voltage signals.

AK-XM 102B is for high voltage signals.

Supply voltage

The supply voltage to the module comes from the previous module in the row.

Light-emitting diodes

They indicate:

- Voltage supply to the module
- Communication with the controller is active (red = error)
- Status of the individual inputs 1 to 8 (when lit = voltage)

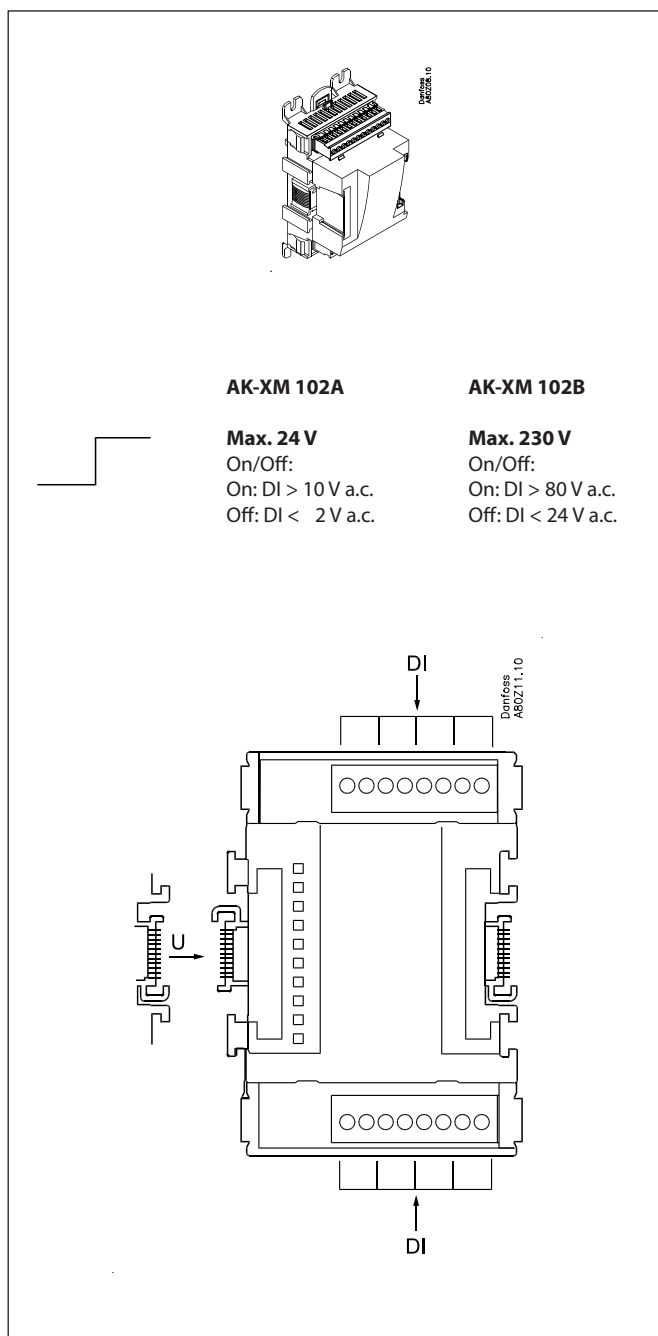

Point

Point	1	2	3	4
Type	DI1	DI2	DI3	DI4

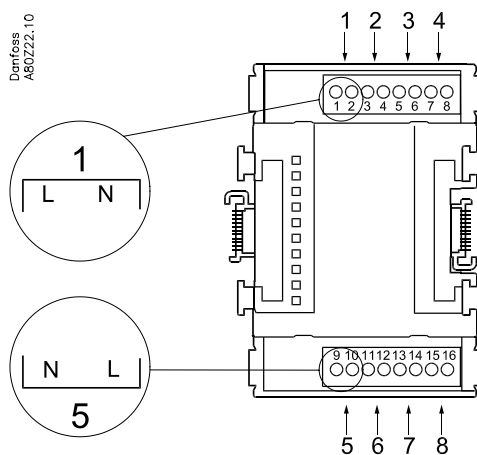

Point	5	6	7	8
Type	DI5	DI6	DI7	DI8

	Signal	Active at
DI AK-XM 102A: Max. 24 V AK-XM 102B: Max. 230 V 	Ext. Main switch Day/ Night Door Defrost	Closed (voltage on) / Open (voltage off)

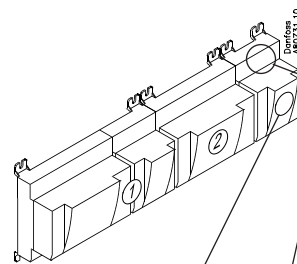

Signal	Module	Point	Terminal	Active at
		1 (DI 1)	1 - 2	
		2 (DI 2)	3 - 4	
		3 (DI 3)	5 - 6	
		4 (DI 4)	7 - 8	
		5 (DI 5)	9 - 10	
		6 (DI 6)	11 - 12	
		7 (DI 7)	13 - 14	
		8 (DI 8)	15 - 16	

Extension module AK-XM 204A / AK-XM 204B

Function

The module contains 8 relay outputs.

Supply voltage

The supply voltage to the module comes from the previous module in the row.

AK-XM 204B only

Override of relay

Eight change-over switches at the front make it possible to override the relay's function.

Either to position OFF or ON.

In position Auto the controller carries out the control.

Light-emitting diodes

There are two rows with LED's. They indicate the following:

Left row:

- Voltage supply to the controller
- Communication active with the bottom PC board (red = error)
- Status of outputs DO1 to DO8

Right row: (AK-XM 204B only):

- Override of relays
- ON = override
- OFF = no override

Fuses

Behind the upper part there is a fuse for each output.

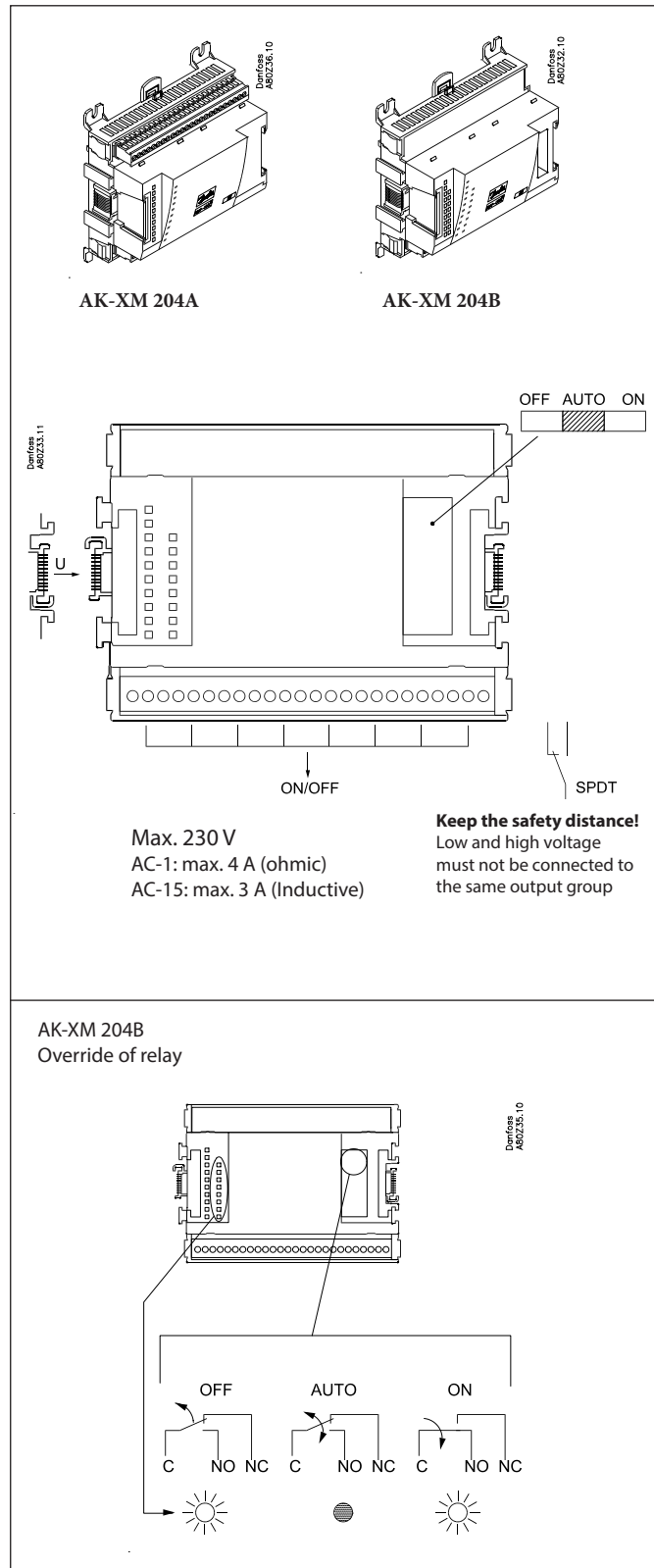

Point

Danfoss
A80Z34.10

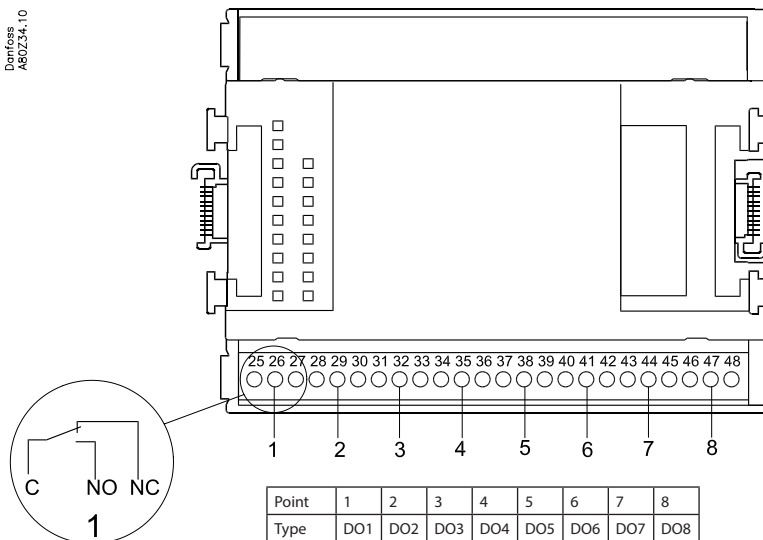

	Signal	Active at
DO	Fan Alarm Light Railheat Defrost Night blind Valve Compressor	On / Off

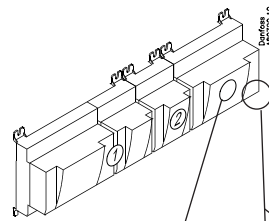

Signal	Module	Point	Terminal	Active at
		1 (DO 1)	25 - 27	
		2 (DO 2)	28 - 30	
		3 (DO 3)	31 - 33	
		4 (DO 4)	34 - 36	
		5 (DO 5)	37 - 39	
		6 (DO 6)	40 - 41 - 42	
		7 (DO 7)	43 - 44 - 45	
		8 (DO 8)	46 - 47 - 48	

Extension module AK-XM 205A / AK-XM 205B

Function

The module contains:
 8 analog inputs for sensors, pressure transmitters, voltage signals and contact signals.
 8 relay outputs.

Supply voltage

The supply voltage to the module comes from the previous module in the row.

AK-XM 205B only

Override of relay

Eight change-over switches at the front make it possible to override the relay's function.

Either to position OFF or ON.

In position Auto the controller carries out the control.

Light-emitting diodes

There are two rows with LED's. They mean:

Left row:

- Voltage supply to the controller
- Communication active with the bottom PC board (red = error)
- Status of outputs DO1 to DO8

Right row: (AK-XM 205B only):

- Override of relays
 ON = override
 OFF = no override

Fuses

Behind the upper part there is a fuse for each output.

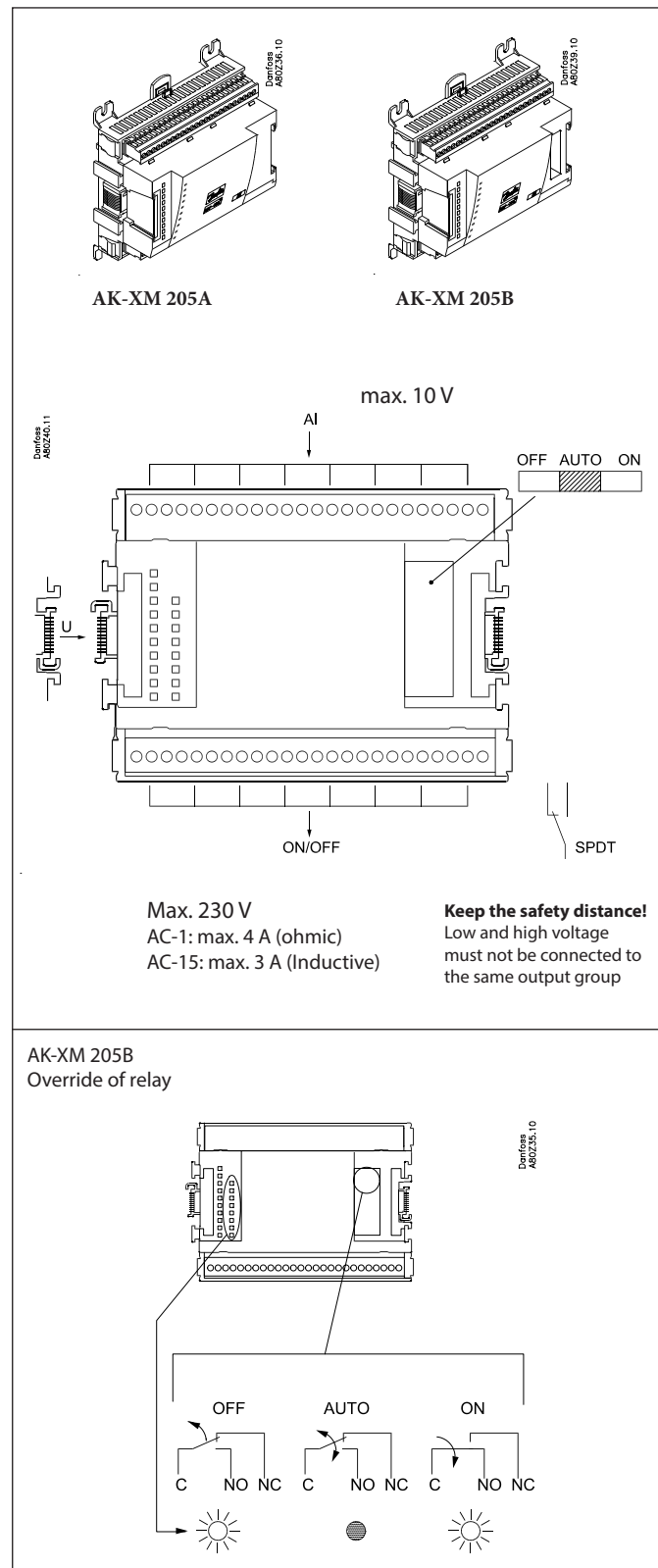

Point

Point	1	2	3	4	5	6	7	8
Type	AI1	AI2	AI3	AI4	AI5	AI6	AI7	AI8

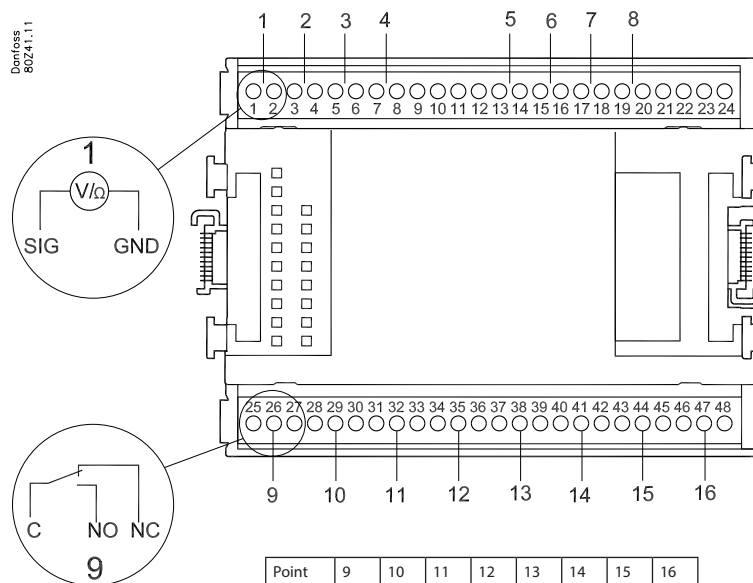

Terminal 9: 12V
Terminal 10: 5V

Terminal 21: 12V
Terminal 22: 5V

Terminal 11, 12, 23, 24: 6 (Cable screen)

Point	9	10	11	12	13	14	15	16
Type	DO1	DO2	DO3	DO4	DO5	DO6	DO7	DO8

	Signal	Signal type
S Pt 1000 ohm/0°C 	S2, S3, S4, S5 Saux	Pt 1000
P AKS 32R AKS 2050 AKS 32 	P0 Pc Paux	AKS 32R AKS 2050 -1 - xx bar AKS 32 -1 - zz bar
U 	...	0 - 5 V 0 - 10 V
On/Off 	Ext. Main switch Day/ Night Door Defrost	Active at: Closed / Open
DO 	Fan Alarm Light Antisweat Defrost Night blind Valve Compr.	Active at: on / Off

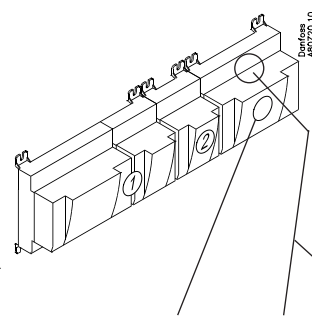

Signal	Module	Point	Terminal	Signal type / Active at
		1 (AI 1)	1 - 2	
		2 (AI 2)	3 - 4	
		3 (AI 3)	5 - 6	
		4 (AI 4)	7 - 8	
		5 (AI 5)	13 - 14	
		6 (AI 6)	15 - 16	
		7 (AI 7)	17 - 18	
		8 (AI 8)	19 - 20	
		9 (DO 1)	25 - 26 - 27	
		10 (DO 2)	28 - 29 - 30	
		11 (DO 3)	31 - 30 - 33	
		12 (DO 4)	34 - 35 - 36	
		13 (DO 5)	37 - 36 - 39	
		14 (DO6)	40 - 41 - 42	
		15 (DO7)	43 - 44 - 45	
		16 (DO8)	46 - 47 - 48	

Extension module AK-OB 101A

Function

The module is a real time clock module with battery backup.

The module can be used in controllers that are not linked up in a data communication unit together with other controllers. The module is used here if the controller needs battery backup for the following functions

- Clock function
- Fixed times for day/night change-over
- Fixed defrost times
- Saving of alarm log in case of power failure
- Saving of temperature log in case of power failure

Connection

The module is provided with plug connection.

Placing

The module is placed on the PC board inside the top part.

Point

No point for a clock module to be defined – just connect it.

Working life of the battery

The working life of the battery is several years – even if there are frequent power failures.

An alarm is generated when the battery has to be replaced.

After the alarm there are still several months of operating hours left in the battery.

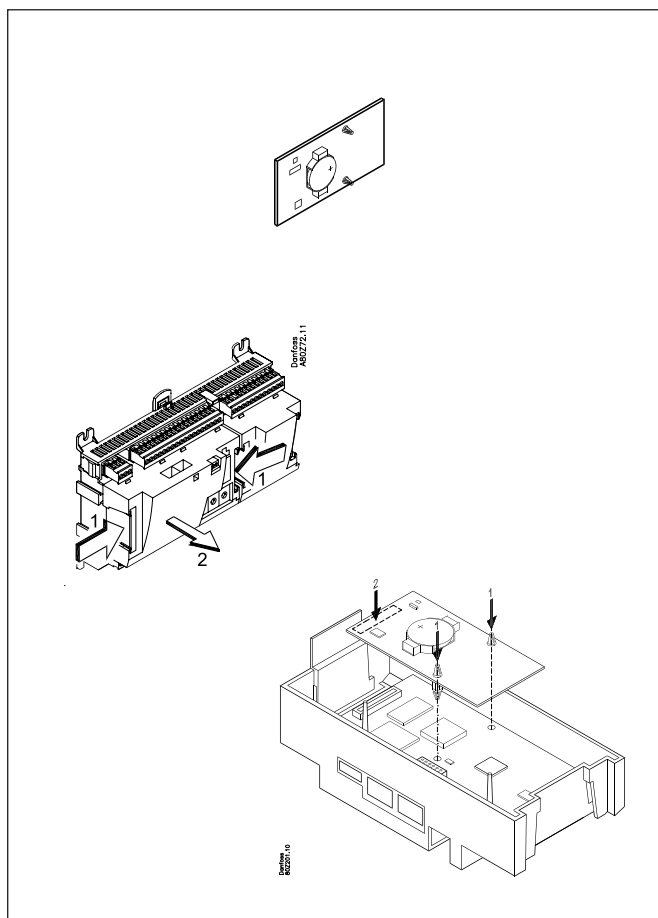

Display module EKA 163B / EKA 164B

Function

Display of important measurements from the controller, e.g. appliance temperature.
 Setting of the individual functions can be performed by using the display with control buttons.
 It is the controller used that determines the measurements and settings that can occur.

Connection

The extension module is connected to the controller module via a cable with plug connections. You have to use one cable per module. The cable is supplied in various lengths.

Both types of display (with or without control buttons) can be connected to either display output A, B, C and D.
 When the controller starts up, the display will show the output that is connected.

- 1 = output A
- 2 = output B
- etc.

Placing

The extension module can be placed at a distance of up to 15 m from the controller module.

Point

No point has to be defined for a display module – you simply connect it.

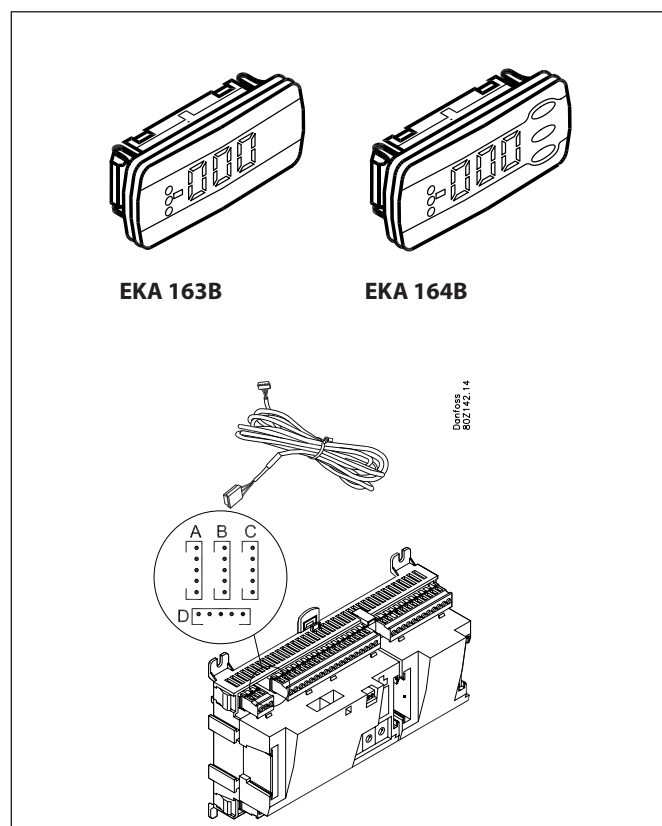

Transformer module AK-PS 075 / 150

Function

24 V supply for controller.

Supply voltage

230 V a.c. or 115 V a.c. (from 100 V a.c. to 240 V a.c.)

Placing

On DIN-rail

Effect

Type	Output tension	Output current	Power
AK-PS 075	24 V d.c.	0.75 A	18 VA
AK-PS 150	24 V d.c. (adjustable)	1.5 A	36 VA

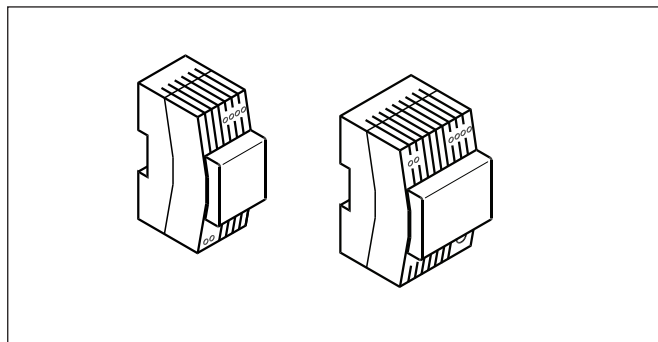

Dimension

Type	High	Width
AK-PS 075	90 mm	36 mm
AK-PS 150	90 mm	54 mm

Supply to a controller

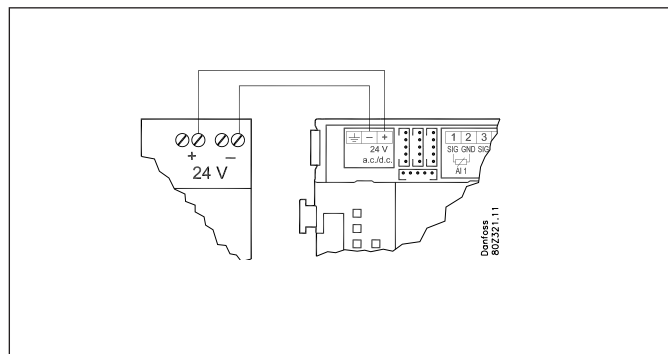

Connections

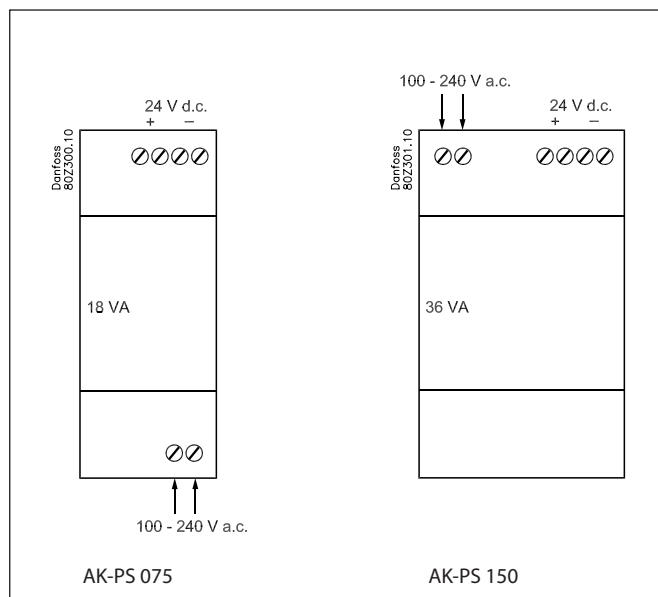

Case Power module

If the AK-CC 750 must be connected to an existing Case Power Module, it must be done as follows:
Connect the Case Power module via the 8-pin Molex connector.

AK-CC 750 are using the following points:

Point	20	21	22	23
Type	ASH	Light	Def	Fan

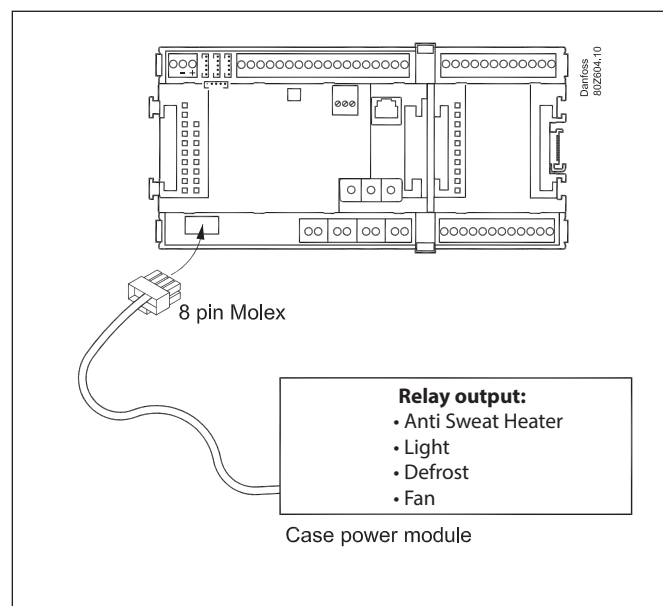

Preface to design

Be aware of the following when the number of extension modules is being planned. A signal may have to be changed, so that an additional module may be avoided.

- An ON/OFF signal can be received in two ways. Either as a contact signal on an analog input or as voltage on a low or high-voltage module.
- An ON/OFF output signal can be given in two ways. Either with a relay switch or with solid state. The primary difference is the permitted load and that the relay switch contains a cutout switch.

Mentioned below is a number of functions and connections that may have to be considered when a regulation has to be planned. There are more functions in the controller than the ones mentioned here, but those mentioned have been included in order that the need for connections can be established.

Functions

Clock function

Clock function and change-over between summer time and winter time are contained in the controller.

The clock is zeroset when there is power failure.

The clock's setting is maintained if the controller is linked up in a network with a gateway, a system manager or a clock module can be mounted in the controller.

Start/stop of regulation

Regulation can be started and stopped via the software. External start/stop can also be connected.

Alarm function

If the alarm is to be sent to a signal transmitter, a relay output will have to be used.

Extra temperature sensors and pressure sensors

If additional measurements have to be carried out beyond the regulation, sensors can be connected to the analog inputs.

Forced control

The software contains a forced control option. If an extension module with relay outputs is used, the module's top part can be with change-over switches – switches that can override the individual relays into either OFF or ON position.

Data communication

The controller module has terminals for LON data communication. The requirements to the installation are described in a separate document. Literature number RC8AC.

Connections

In principle there are the following types of connections:

Analog inputs "AI"

This signal must be connected to two terminals.

Signals can be received from the following sources:

- Temperature signal from Pt 1000 ohm temperature sensor
- Contact signal where the input is short-circuited or "opened", respectively
- Voltage signal from 0 to 10 V
- Signal from pressure transmitter AKS 32, AKS 32R or AKS 2050.

The supply voltage is supplied from the module's terminal board where there is both a 5 V supply and a 12 V supply.

When programming the pressure transmitter's pressure range must be set.

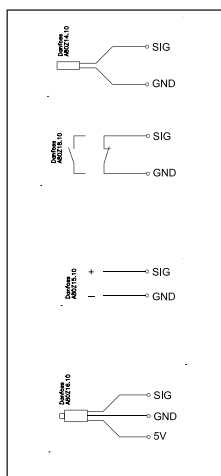

ON/OFF voltage inputs "DI"

This signal must be connected to two terminals.

- The signal must have two levels, either 0 V or "voltage" on the input.

There are two different extension modules for this signal type:

- low-voltage signals, e.g. 24 V
- high-voltage signals, e.g. 115 V

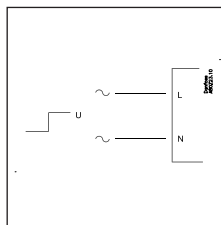

When programming the function must be set:

- Active when the input is without voltage
- Active when voltage is applied to the input.

ON/OFF output signals "DO"

There are two types, as follows:

- Relay outputs
All relay outputs are with change-over relay so that the required function can be obtained when the controller is without voltage.
- Solid state outputs
Primarily for AKV valves which connect quickly. But output can cut an external relay in and out, as with a relay output. The output is only found on the controller module.

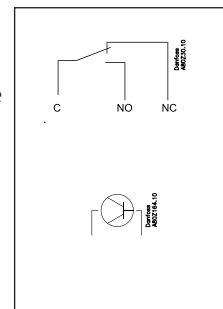

When programming the function must be set:

- Active when the output is activated
- Active when the output is not activated.

Limitations

As the system is very flexible regarding the number of connected units you must check whether your selection complies with the few limitations there are.

The complexity of the controller is determined by the software, the size of the processor, and the size of the memory. It provides the controller with a certain number of connections from which data can be downloaded, and others where coupling with relays can be performed.

The controller **is not** made for use on plate heat exchanger.

- ✓ The sum of connections cannot exceed **80**.
- ✓ The number of extension modules must be limited so that the total power will not exceed **32 VA** (including controller).
- ✓ No more than **5** pressure transmitters may be connected to one controller module.
- ✓ No more than **5** pressure transmitters may be connected to one extension module.

Design of a evaporator control

Procedure:

1. Make a sketch of the system in question
2. Check that the controller's functions cover the required application
3. Consider the connections to be made
4. Use the planning table. / Note down the number of connections
./ add up
5. Are there enough connections on the controller module? – If not, can they be obtained by changing an ON/OFF input signal from voltage signal to contact signal, or will an extension module be required?
6. Decide which extension modules are to be used
7. Check that the limitations are observed
8. Calculate the total length of modules
9. The modules are linked together
10. The connection sites are established
11. Draw a connection diagram or a key diagram
12. Size of supply voltage/transformer

← Follow these 12 steps

1

Sketch

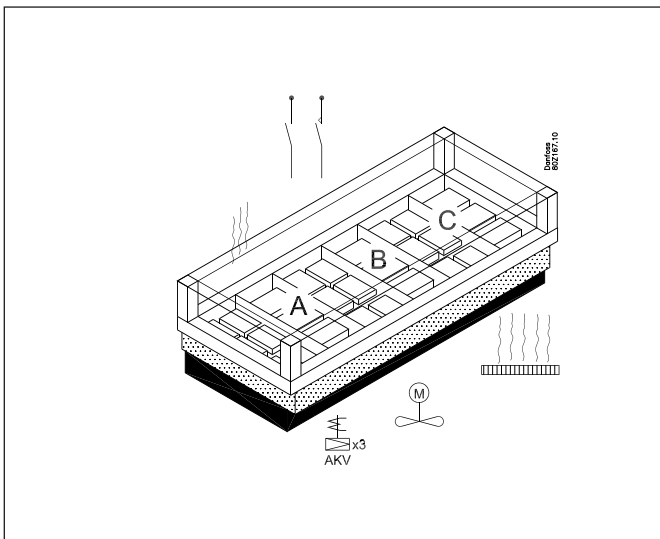

Make a sketch of the system in question.

2 Evaporator and refrigerator appliance functions

	AK-CC 750
Application	
Control of cold room or freezing room	x
Control of refrigeration or freezing appliances	x
Regulation of evaporators	1 - 4
Thermostat function	
Common thermostat function for all sections	x
Thermostat function for each section	x
On/off thermostat with AKV or solenoid valve	x
Modulating thermostat with AKV valve	x
Change between two thermostat references (thermostat band)	x
Day/night switch	x
Displacement of reference via analog input signal	x
Thermostat sensor before or after evaporator	x
Thermostat sensor both before and after the evaporator (weighted thermostat)	x
Alarm thermostat (weighted)	x
Common functions	
Fan control (pulsation)	x
Rail heat control (pulsation)	x
Compressor control. Relay active when refrigeration is demanded	x
Appliance cleaning function	x
Appliance shut down	x
Door contact function	x
Light function	x
Night blind	X
Forced closing	x
Alarm output	x
Start / stop of regulation	x
Product sensor with alarm function	4

Liquid injection	
Control of AKV valves	4
Control of solenoid valves	4
Superheat regulation with P0 and S2 measurement	x
MOP control	x
Refrigerant choice	x
Defrost function	
Electrical defrost	4
Warm Brine defrost, Hot gas defrost	x
Smelt function	x
Drip tray heat	X
Adaptive defrost	x
Defrost stop on temperature or time	x
Coordinated defrost via network	x
Miscellaneous	
Alarm priorities	x
Sensor correction	x
Option for connection of separate display	4
System signals via data communication	
Signal for P0-optimisation	x
Night setback	x
Inject ON-signal (forced closing)	x
Light control	x
Coordinated defrost	x
Forced cooling	x

A bit more about the functions

Common thermostat

The thermostat temperature can be either a weighting of the S3 and S4 sensors in section A. Alternatively, the thermostat temperature can be a minimum value, a maximum value or an average value of all S3 or S4 sensors for the refrigeration sections used.

Modulating thermostat

AKV:

The function can only be used on central plant.

The opening degree of the valve is adjusted so that an accurate, constant temperature is maintained. .

Solenoid valve:

This function can be used on both central systems and on indirect refrigeration appliances. The valve's duty cycle is adapted so that optimum temperature regulation is achieved on the basis of a specific time period. The valve's duty cycle is desynchronised so that an even load is achieved across the entire system

Changeover between two thermostat references

The function is used for appliances where contents are frequently changed and where a different thermostat reference is required. Changeover between the two references can take place by means of a switch function.

Day/night signal for raising the reference

The built-in week diagram can be used for raising the thermostat reference, but it is also possible to use an external ON/OFF signal or a signal via the network.

Product sensors

Each appliance section has a separate product sensor which can be used for monitoring/registering the temperature.

Appliance cleaning function

A switch function with pulse pressure will activate the function whereupon refrigeration will be stopped. The fans continue operating.

"Later": Next push on the switch will stop the fans.

"Still later": Next push on the switch will restart refrigeration.

When a display is mounted at the appliance the various situations may be followed by the readout:

Normal operation: Appliance temperature

1st push: Fan

2nd push: OFF

3rd push: Appliance temperature

Appliance shut down

Signal about shutdown can be received via data communication or from a contact on a On/Off input.

Door switch function

In freezing and coldrooms the door switch is used for switching the light on and off, for starting and stopping the refrigeration, and for sounding the alarm if the door has been open for a long time

Light function

The light function can be activated by the door switch, the internal time diagram or a signal via the network.

Defrost sensor S5

On long evaporators it may be necessary to mount two sensors in order to ensure the correct defrost of the evaporator. The sensors are for example named S5A-1 and S5A-2.

"Inject ON" override function

The function closes expansion valves on the evaporator control when all compressors are stopped.

The function can take place via the data communication, or it may be wired via a relay output.

Adaptive defrost

The function requires signals from S3 and S4 as well as from condensing pressure P_c. The expansion valve must furthermore be type AKV.

The function cannot be used in combination with pulsation of fans.

If you want to know more about the functions, go to chapter 5.

3

Connections

Here is a survey of the possible connections. The texts can be read in context with the planning table in point 4.

Analog inputs

Temperature sensors each section

- S3 air sensor at evaporator inlet
- S4 air sensor at evaporator outlet (one of the S3/S4 sensors may be omitted)
- S5 defrost sensor. Two may be used for long sections
- Product sensor. Extra sensor that only checks the product temperature
- S2 gas sensor at evaporator outlet (control of AKV valve).

Pressure transmitters

- P0 For registration of the evaporating pressure (control of AKV valve).
- Pc For registration of the condensing pressure. Can be used in connection with adaptive defrost, or the signal can be received via data communication.

A pressure transmitter type AKS 32R can supply signals to five controllers

Voltage signal

Ext. Ref. is used if the thermostat reference is to be displaced with a signal from another control.

On/Off-inputs

Contact function (on an analog input) or voltage signal (on an extension module)

- External start/stop of regulation
- Pulse pressure used for the "appliance cleaning" function
- Switch for changeover between two temperature reference
- Inject ON. Signal from a compressor control
- Pulse pressure for start of defrost
- Pulse pressure for opening/closing Night blind
- Door switch in coldroom
- External day/night signal (raises the temperature reference when Night blind is used)

On/off-output

Relay outputs

- Defrost (one each section)
- Rail heat
- Fan motor
- Light
- Compressor (demand on cooling)
- Alarm relay
- Solenoid valve (EVR)
- Drain valve, Suction line valve
- Night blind
- Drip tray heat recovery

AKV Solid state outputs

The solid state outputs on the controller module are primarily used for AKV valves, but may also be used for the functions mentioned under "relay outputs".
(The output will always be "OFF" when the controller is hit by power failure).

Example

- Freezing appliance with three sections
- AKV is used for injections (S2 and P0)
- Electric defrost with stop based on temperature (S5)
- Two thermostat sensors per section (S3 and S4)
- Control of fans and rail heat
- External start/stop (Main switch)
- Switch signal for appliance cleaning
- 3 display for monitoring of appliance temperature

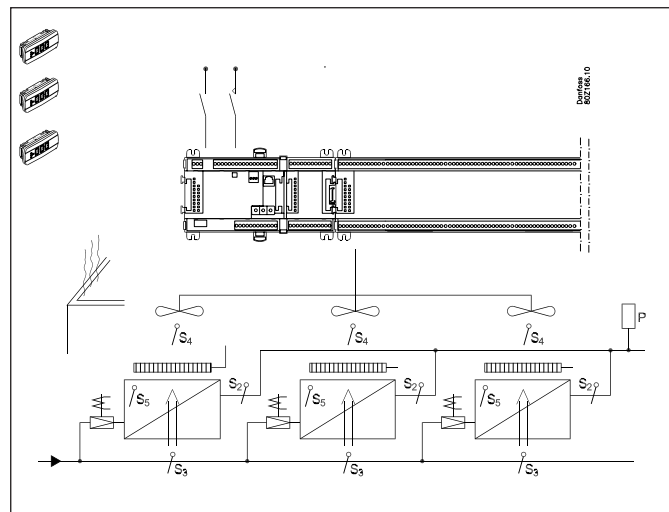

Data from this example is used in the planning table on the next page.

The result is that the following modules should be used:

- AK-CC 750 controller
- AK-XM 101A
- 3 pcs. EKA 163B

If the result had demonstrated that an additional output was needed, AK-XM 205A or B would have been the required extension.

4	Planning table The table helps you establish whether there are enough inputs and outputs on the basic controller. If there are not enough of them, the controllers must be extended by one or more of the mentioned extension modules. Note down the connections you will require and add them up	Analog input signal		On/off voltage signal		On/off voltage signal		On/Off output signal		7 Limitations
		Example		Example		Example		Example		
	Analog inputs									P = Max. 5 / module The example: None of the 3 limitations are exceeded => OK
	Temperature sensors, S3, S4		6							
	Defrost sensors, S5		3							
	Product temperature sensor									
	Gas temperature sensor S2		3							
	Pressure transmitter P0		1							
	Pressure transmitter Pc									
	Displacement of reference with analog signal									
	On/off inputs	contact		24 V		230 V				
	External start/stop (Main switch)		1							
	Case cleaning (pulse pressure). Shutdown		1							
	Switch between two temperature references									
	Inject ON									
	Start of defrost (pulse pressure)									
	Door contact									
	Night setback									
	Open/ close Night blind (pulse pressure)									
	On/off outputs									
	AKV valves							3		
	Solenoid valves (when TEV valves is used))									
	Fans							1		
	Defrost (electric or hot gas valves)							3		
	Drain valve, suction line valve									
	Antisweat heat							1		
	Light									
	Night blind									
	Drip tray heat									
	Compressor									
	Alarm									
	Sum of connections for the regulation		15					8	Sum = max. 80	
	Number of connections on a controller module	11	11	0	0	0	0	8	8	
5	Missing connections, if applicable		3		-		-		0	
6	The missing connections to be updated from one or more extension modules:								Sum of power	
	AK-XM 101A (8 analog inputs)		+1						___ pcs. á 2 VA = ___	
	AK-XM 102A (8 digital low voltage inputs)								___ pcs. á 2 VA = ___	
	AK-XM 102B (8 digital high voltage outputs)								___ pcs. á 2 VA = ___	
	AK-XM 204A / B (8 relay outputs)								___ pcs. á 5 VA = ___	
	AK-XM 205A / B (8 analog inputs + 8 relay outputs)								___ pcs. á 5 VA = ___	
	Case Power module (4 relay outputs. 12/24 A)								___ pcs. á 3 VA = ___	
									1 pcs. á 8 VA = 8	
									Sum =	
									Sum = max. 32 VA	

8 Length

If you use many extension modules the controller's length will grow accordingly. The row of modules is a complete unit which cannot be broken.

The module dimension is 72 mm (2.83").

Modules in the 100-series consist of one module

Modules in the 200-series consist of two modules

The controller consist of three modules

The length of an aggregate unit = $n \times 2.83" + 0.32"$

or in an other way:

Module	Type	Number	at	Length
Controller module		1	x	8.82" = 8.82"
Extension module	200-series	–	x	5.67" = "
Extension module	100-series	–	x	2.83" = "
Total length				= "

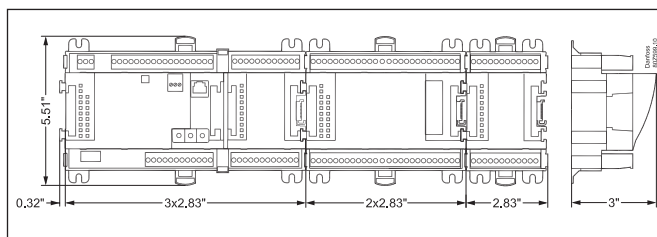

Example continued:

Controller module + 1 extension module in 100-series = $8.82 + 2.83 = 11.65"$

9 Linking of modules

Start with the controller module and then mount the selected extension modules. The sequence is of no importance.

However, you must **not** change the sequence, i.e. rearrange the modules, after you have made the setup where the controller is told which connections are found on which modules and on which terminals.

The modules are attached to one another and kept together by a connection which at the same time transmits the supply voltage and the internal data communication to the next module.

Mounting and removal must always be performed when there is no voltage.

The protective cap mounted on the controller's plug connection must be moved to the last vacant plug connection so that the plug will be protected against short-circuit and dirt.

When the regulation has started the controller will all the time check whether there is connection to the connected modules. This status can be followed by the light-emitting diode.

When the two catches for the DIN rail mounting are in open position the module can be pushed into place on the DIN rail – no matter where in the row the module is found. Removal is likewise carried out with the two catches in the open position.

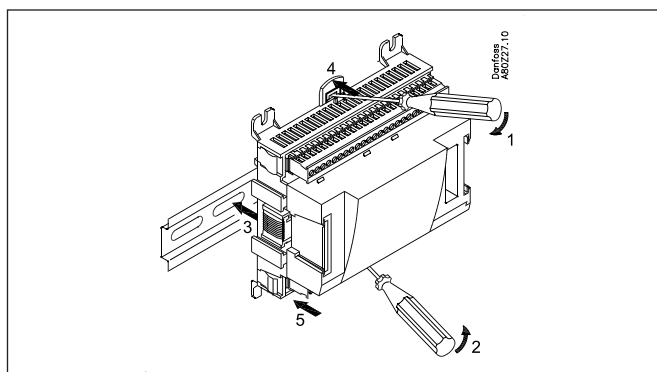
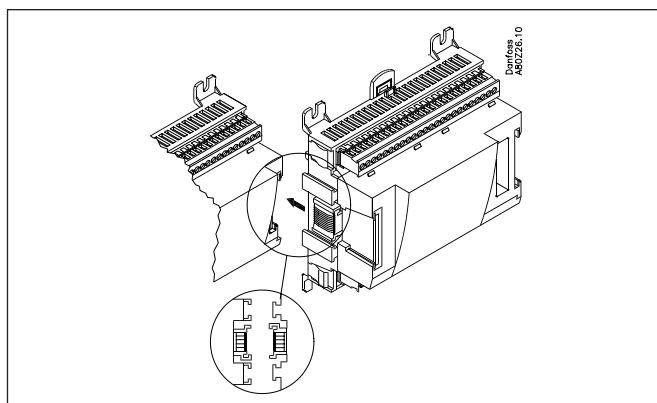
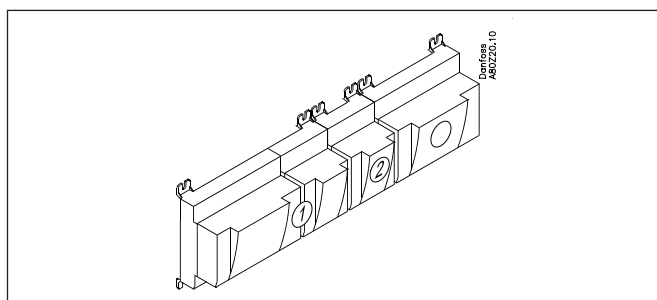

10 Determine the connection points

All connections must be programmed with module and point, so in principle it does not matter where the connections are made, as long as it takes place on a correct type of input or output.

- The controller is the first module, the next one is 2, etc.
- A point is the two or three terminals belonging to an input or output (e.g. two terminals for a sensor and three terminals for a relay).

The preparation of the connection diagram and the subsequent programming (configuration) should take place at the present time. It is most easily accomplished by filling in the connection survey for the relevant modules.

Principle:

Name	On module	On Point	Function
fx Compressor 1	x	x	ON
fx Compressor 2	x	x	ON
fx Alarm relay	x	x	OFF
fx Main switch	x	x	Close
fx P0	x	x	AKS 32R 1-6 bar

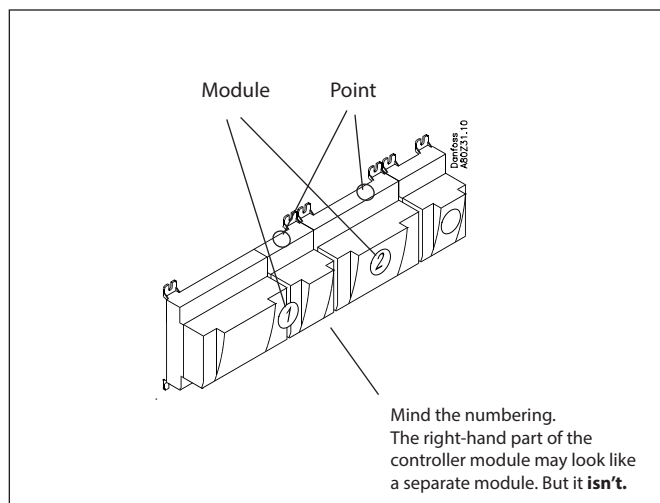

The connection survey from the controller and any extension modules are uploaded from the paragraph "Module survey. E.g. controller module:

Signal	Module	Point	Terminal	Signal type / Active at
/		1 (AI 1)	1 - 2	
/		2 (AI 2)	3 - 4	
/		3 (AI 3)	5 - 6	
/		4 (AI 4)	7 - 8	

- Columns 1, 2, 3 and 5 are used for the programming.
- Columns 2 and 4 are used for the connection diagram.

Tip
The Appendix shows 80 general installation types. If your plant closely resembles one of those shown, you can use the connection points indicated for it.

Example continued:

Signal	Module	Point	Terminal	Signal type / Active at	
Air temperature - S3A	1	1 (AI 1)	1 - 2	Pt 1000	
Air temperature- S3B		2 (AI 2)	3 - 4	Pt 1000	
Air temperature- S3C		3 (AI 3)	5 - 6	Pt 1000	
Air temperature - S4A		4 (AI 4)	7 - 8	Pt 1000	
Air temperature - S4B		5 (AI 5)	9 - 10	Pt 1000	
Air temperature - S4C		6 (AI 6)	11 - 12	Pt 1000	
Defrost sensor - S5A		7 (AI 7)	13 - 14	Pt 1000	
Defrost sensor - S5B		8 (AI 8)	19 - 20	Pt 1000	
Defrost sensor - S5C		9 (AI 9)	21 - 22	Pt 1000	
Gas temperature - S2A		10 (AI 10)	23 - 24	Pt 1000	
Evaporator pressure - P0		11 (AI 11)	25 - 26	AKS32R-12	
AKV A		12 (DO 1)	31 - 32	-	
AKV B		13 (DO 2)	33 - 34	-	
AKV C		14 (DO 3)	35 - 36	-	
Fans		15 (DO 4)	37 - 38	ON	
Defrost A		16 (DO 5)	39-40-41	ON	
Defrost B		17 (DO6)	42-43-44	ON	
Defrost C		18 (DO7)	45-46-47	ON	
Rail heat		19 (DO8)	48-49-50	ON	
			24	-	
			25	-	

Signal	Module	Point	Terminal	Signal type / Active at
Gas temperature - S2B	2	1 (AI 1)	1 - 2	Pt 1000
Gas temperature - S2C		2 (AI 2)	3 - 4	Pt 1000
External Start/stop		3 (AI 3)	5 - 6	Closed
Case cleaning (pulse pressure)		4 (AI 4)	7 - 8	Closed
		5 (AI 5)	17 - 18	
		6 (AI 6)	19 - 20	
		7 (AI 7)	21 - 22	
		8 (AI 8)	23 - 24	

11 Connection diagram

Drawings of the individual modules may be ordered from Danfoss.
Format = dwg and dxf.

You may then yourself write the module number in the circle and draw the individual connections.

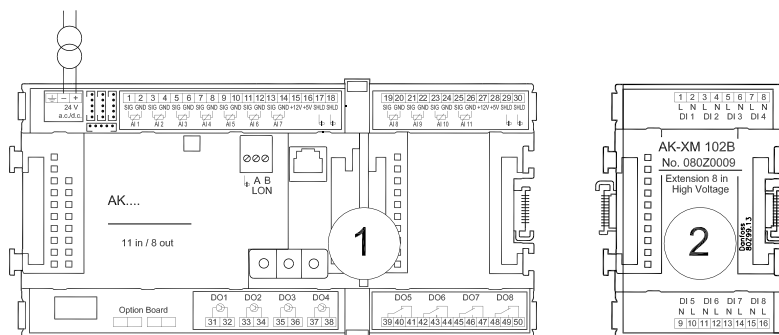

Example continued:

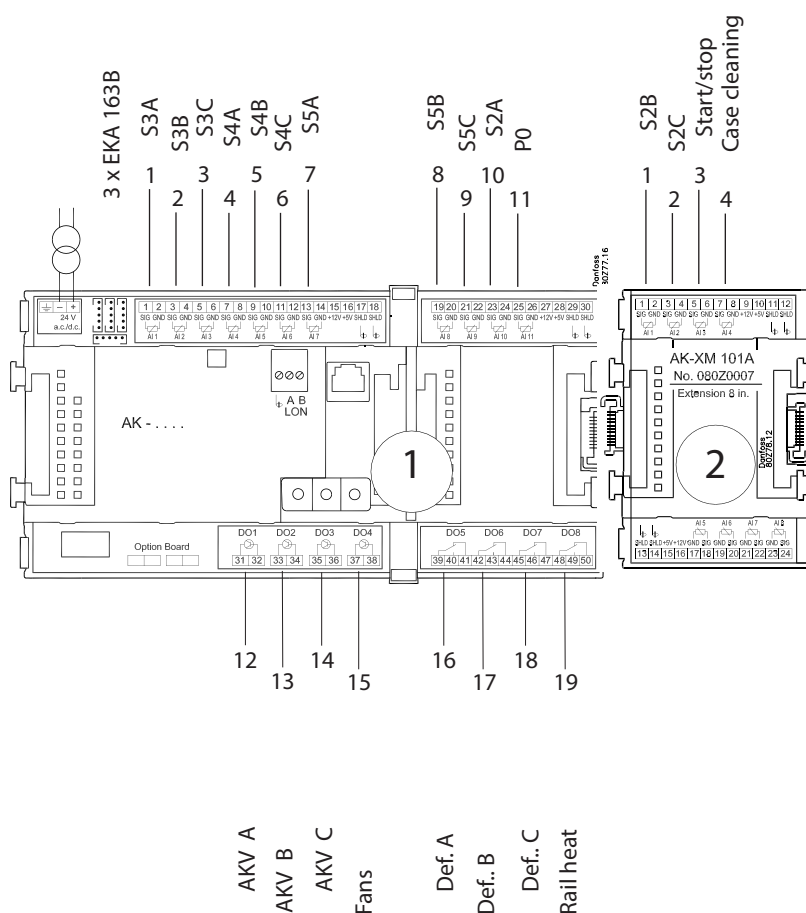

12 Supply voltage

Supply voltage is only connected to the controller module. The supply to the other modules is transmitted via the plug between the modules. The supply must be 24 V +/-20%. One transformer must be used for each controller. The transformer must be a class II. The 24 V must not be shared by other controllers or units. The analog inputs and outputs are not galvanically separated from the supply.

Transformer size

The power consumption grows with the number of modules used:

Module	Type	Number	á	Effect
Controller		1	x 8 =	8 VA
Extension module	200-series	—	x 5 =	— VA
Extension module	100-series	—	x 2 =	— VA
Total				— VA

The + and – 24V input must not be earthed.

Example continued:

Controller module	8 VA
+ 1 extension module in 100-series	2 VA

Transformer size (least)	10 VA

Ordering

1. Controller

Type	Function	Application	Language	Code no.	Example continued
AK-CC 750	Controller for evaporator control With LON TP 78 communication	1, 2, 3 or 4 sections	English (US), English (UK)	080Z0130	x
	Controller for evaporator control With LON RS 485 communication			080Z0139	

2. Extension modules and survey for inputs and outputs

Type	Analog inputs	On/Off outputs		On/off supply voltage (DI signal)		Module with switches	Code no.	Example continued
	For sensors, pressure transmitters etc.	Relay (SPDT)	Solid state	Low voltage (max. 80 V)	High voltage (max. 260 V)	For override of relay outputs		
Controller	11	4	4	-	-	-	-	
Extension modules								
AK-XM 101A	8						080Z0007	x
AK-XM 102A				8			080Z0008	
AK-XM 102B					8		080Z0013	
AK-XM 204A		8					080Z0011	
AK-XM 204B		8				x	080Z0018	
AK-XM 205A	8	8					080Z0010	
AK-XM 205B	8	8				x	080Z0017	

3. AK operation and accessories

Type	Function	Application	Code no.	Example continued
Operation				
AK-ST 500	Software for operation of AK controllers	AK-operation	080Z0161	x
-	Cable between PC and AK controller	AK - Com port	080Z0262	x
-	Cable between zero modem cable and AK controller / Cable between PDA cable and AK controller	AK - RS 232	080Z0261	
-	Cable between PC and AK controller	AK - USB	080Z0264	
Accessories	Transformer module 230 V / 115 V to 24 V			
AK-PS 075	18 VA	Supply for controller	080Z0053	x
AK-PS 150	36 VA		080Z0054	
Accessories	External display that can be connected to the controller module. For showing, say, the appliance temperature			
EKA 163B	Display		084B8574	xxx
EKA 164B	Display with operation buttons		084B8575	
-	Cable between display and controller	Length = 6.5 ft	084B7298	xxx
		Length = 19.5 ft	084B7299	
Accessories	Real time clock for use in controllers that require a clock function, but are not wired with data communication.			
AK-OB 101A	Real time clock with battery backup.	To be mounted in an AK controller	080Z0252	

3. Mounting and wiring

This section describes how the controller:

- Is fitted
- Is connected

We have decided to work on the basis of the example we went through previously, i.e. the following modules:

- AK-CC 750 controller module (TP 78 version)
- AK-XM 101A analog output module
- 3 pcs. EKA 163B display

Mounting

Mounting of extension module on the basic module

1. Move the protective cap

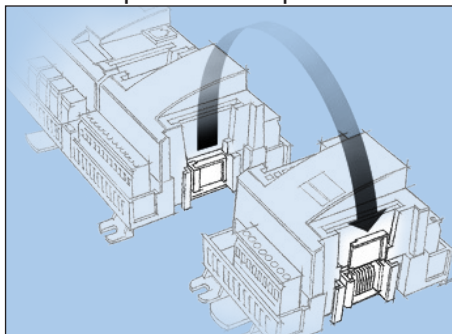

Remove the protective cap from the connection plug on the right-hand side of the basic module.
Place the cap on the connection plug to the right of the extension module that is to be mounted on the extreme right-hand side of the AK assembly.

2. Assemble the extension module and the basic module

The basic module must not be connected to voltage.

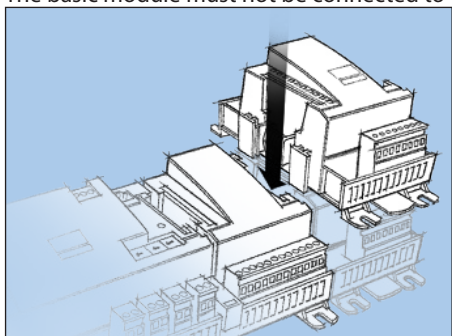

In our example one extension module is to be fitted to the basic module. The sequence is thus:

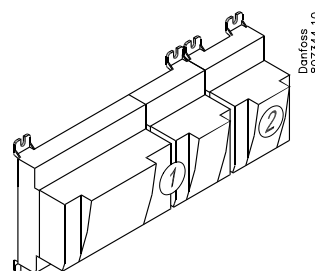

All the subsequent settings that affect the two extension modules are determined by this sequence.

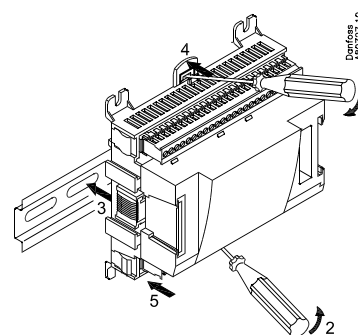
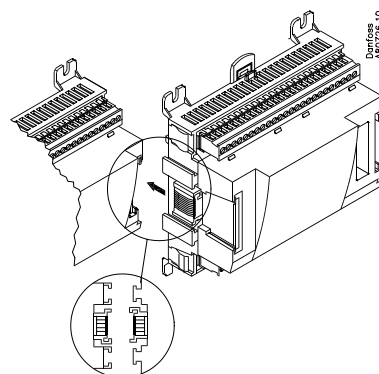

When the two snap catches for the DIN rail mounting are in the open position, the module can be pushed into place on the DIN rail – regardless of where the module is on the row.
Disassembly is thus done with the two snap catches in the open position.

Wiring

Decide during planning which function is to be connected and where this will be.

1. Connect inputs and outputs

Here are the tables for the example:

Signal	Module	Point	Terminal	Signal type / Active at	
Air temperature - S3A	1	1 (AI 1)	1 - 2	Pt 1000	
Air temperature- S3B		2 (AI 2)	3 - 4	Pt 1000	
Air temperature- S3C		3 (AI 3)	5 - 6	Pt 1000	
Air temperature - S4A		4 (AI 4)	7 - 8	Pt 1000	
Air temperature - S4B		5 (AI 5)	9 - 10	Pt 1000	
Air temperature - S4C		6 (AI 6)	11 - 12	Pt 1000	
Defrost sensor - S5A		7 (AI 7)	13 - 14	Pt 1000	
Defrost sensor - S5B		8 (AI 8)	19 - 20	Pt 1000	
Defrost sensor - S5C		9 (AI 9)	21 - 22	Pt 1000	
Gas temperature - S2A		10 (AI 10)	23 - 24	Pt 1000	
Evaporator pressure - P0		11 (AI 11)	25 - 26	AKS32R-12	
AKV A		12 (DO 1)	31 - 32	-	
AKV B		13 (DO 2)	33 - 34	-	
AKV C		14 (DO 3)	35 - 36	-	
Fans		15 (DO 4)	37 - 38	ON	
Defrost A		16 (DO 5)	39-40-41	ON	
Defrost B		17 (DO6)	42-43-44	ON	
Defrost C		18 (DO7)	45-46-47	ON	
Rail heat		19 (DO8)	48-49-50	ON	
			24	-	
			25	-	

Signal	Module	Point	Terminal	Signal type / Active at
Gas temperature - S2B	2	1 (AI 1)	1 - 2	Pt 1000
Gas temperature - S2C		2 (AI 2)	3 - 4	Pt 1000
External Start/stop		3 (AI 3)	5 - 6	Closed
Case cleaning (pulse pressure)		4 (AI 4)	7 - 8	Closed
		5 (AI 5)	17 - 18	
		6 (AI 6)	19 - 20	
		7 (AI 7)	21 - 22	
		8 (AI 8)	23 - 24	

The function of the switch functions can be seen in the last column.

The connections for the example can be seen here.

Warning
Keep signal cables separate from cables with high voltage.

The screen on the pressure transmitter cables must only be connected at the end of the controller.

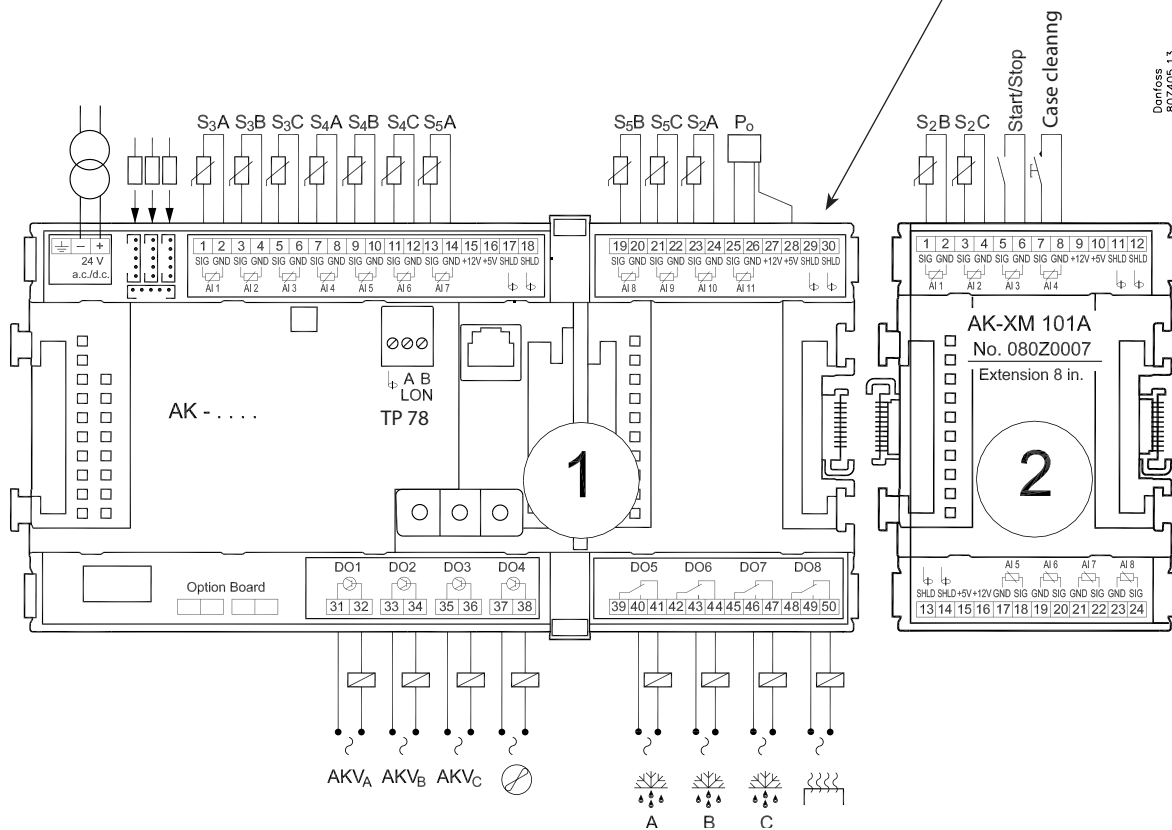

2. Connect LON TP 78 communication network

The installation of the data communication must comply with the requirements set out in document RC8AC.

3. Connect supply voltage

Is 24 V, and the supply must not be used by other controllers or devices. The terminals must not be earthed.

4. Follow light-emitting diodes

When the supply voltage is connected the controller will go through an internal check. The controller will be ready in just under one minute when the light-emitting diode "Status" starts flashing slowly.

5. When there is a network

Set the address and activate the Service Pin.

When the controller is set correct on the network the LED "status" will flash quickly for 10 minutes.

6. The controller is now ready to be configured.

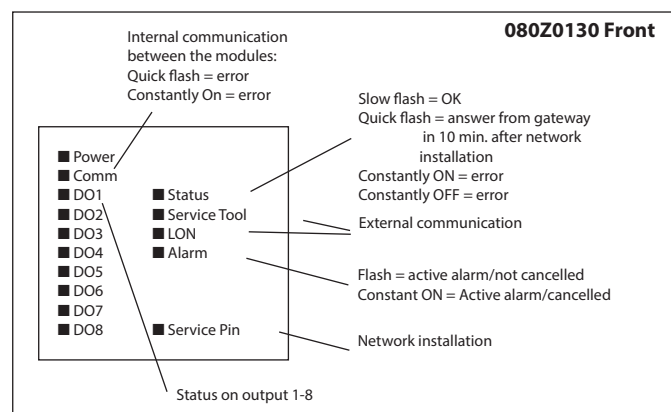

4. Configuration and operation

This section describes how the controller:

- Is configured
- Is operated

We have decided to work on the basis of the example we went through previously, i.e. a frost appliance with 3 evaporators. The example is shown overleaf.

Refrigerating plant example

We have decided to describe the setup by means of an example comprising a freezing appliance with 3 evaporators. The example is the same as the one given in the "Design" section, i.e. the controller is an AK-CC 750 + extension modules.

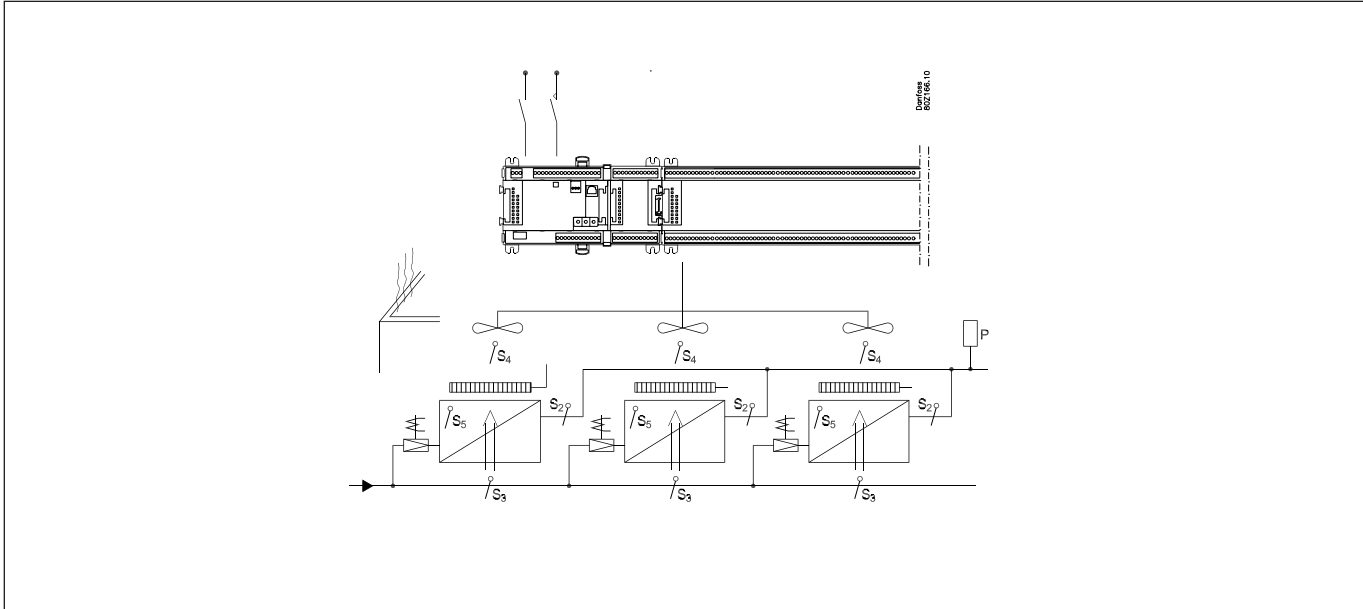

Freezing appliance

- Refrigerant R134a
- 3 evaporators
- Electric defrost on each section
- Fans
- Rail heat
- 3 displays for monitoring of temperature in the sections

Refrigeration:

- 3 AKV valves
- Superheat measured with P0 and 3 S2-sensors
- S3 is alarm sensor
- S4 is thermostat sensor
- Night setback on 5°F

Defrost:

- The defrost is stopped individually based on temperature (S5)
- Refrigeration starts when both defrosts have been accomplished

Fans:

- Operates during defrost

Cleaning:

- Pulse pressure for start and later stop of cleaning

Other:

- External start/stop used (Main switch)

For the example shown we use the following modules:

- AK-CC 750 controller
- AK-XM 101A analog output module

There is also an internal main switch as a setting. Both must be "ON" before any adjustment is made.

The modules used are selected in the design phase.

Configuration

Connect PC

PC with the program "Service Tool" is connected to the controller.

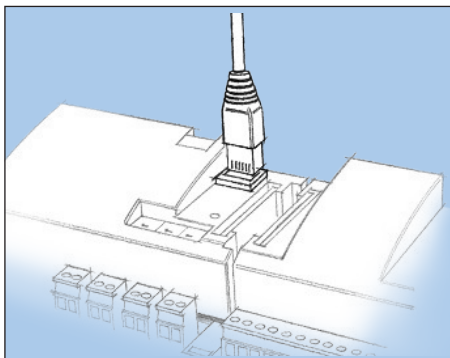

The controller must be switched on first and the LED "Status" must flash before the Service Tool programme is started.

Start Service Tool programme

Login with user name SUPV

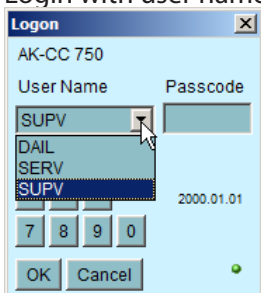

Select the name **SUPV** and key in the access code.

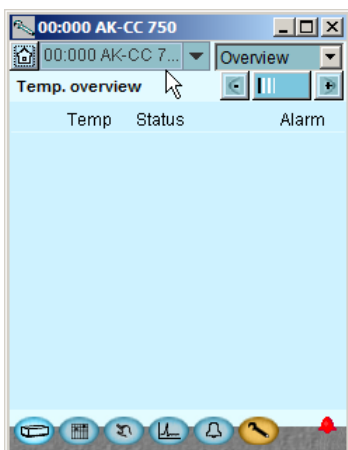

For connecting and operating the "AK service tool" software, please see the manual for the software.

The first time the Service Tool is connected to a new version of a controller the start-up of the Service Tool will take longer than usual while information is retrieved from the controller. Time can be followed on the bar at the bottom of the display.

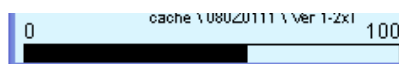

When the controller is supplied the SUPV access code is 123. When you are logged into the controller an overview of it will always appear.

In this case the overview is empty. This is because the controller has not yet been set up. The red alarm bell at the bottom right tells you that there is an active alarm in the controller. In our case the alarm is due to the fact that the time in the controller has not yet been set.

Authorization

1. Go to Configuration menu

Press the orange setup button with the spanner at the bottom of the display.



2. Select Authorization

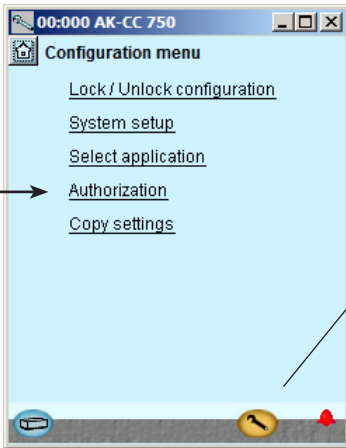

3. Change setting for the user 'SUPV'

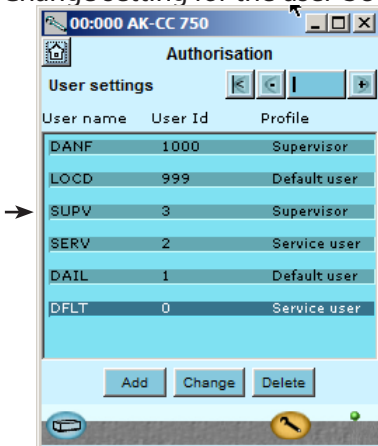

4. Select user name and access code

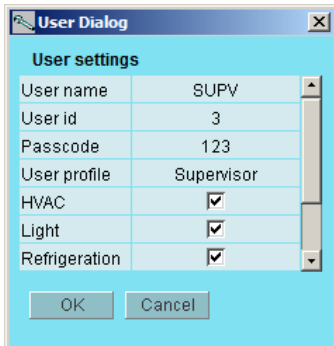

5. Carry out a new login with the user name and the new access code

When the controller is supplied it has been set with standard authorization for different user interfaces. This setting should be changed and adapted to the plant. The changes can be made now or later.

You will use this button again and again whenever you want to get to this display.

On the left-hand side are all the functions not shown yet. There will be more here the further into the setup we go.

Press the line **Authorization** to get to the user setup display.

Mark the line with the user name **SUPV**.

Press the button **Change**

This is where you can select the supervisor for the specific system and a corresponding access code for this person.

The controller will utilize the same language that is selected in the service tool but only if the controller contains this language. If the language is not contained in the controller, the settings and readings will be shown in English.

To activate the new settings you must carry out a new login to the controller with the new user name and the relevant access code.

You will access the login display by pressing the "Home" at the top left corner of the display.



Unlock the configuration of the controllers

1. Go to Configuration menu



If you want to know more about the different configuration options, they are listed below. The number refers to the number and picture in the column on the left.

2. Select Lock/Unlock configuration

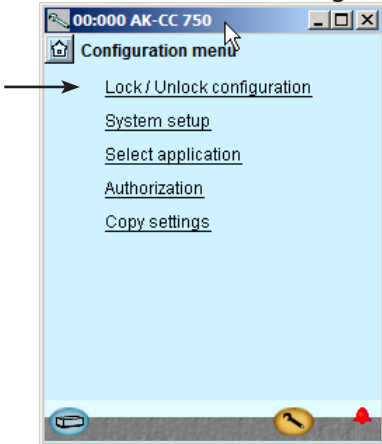

The controller can only be configured when it is unlocked.
It can only be adjusted when it is locked.

Changes to the input and output settings are only enabled when the controller is "Locked"

The values can be changed when it is locked, but only for those settings that do not affect the configuration.

In general
Many settings are dependent on previous settings. This is shown by the fact that a function can only be seen (and thus set) if an earlier parent function allows access to this subordinate function

For example, the "Configuration lock" line will not be shown if the main switch is set to On. Only when the main switch is set to Off, and regulation has therefore been stopped, is it possible to set the configuration lock.

3-

Main Switch

Used to start and stop regulation. When the main switch is set to Off, all outputs are in standby mode and all alarms are cancelled. The main switch must be set to Off before the Configuration lock can be Unlocked.

Configuration lock

The controller can only be fully configured when the configuration lock is set to Unlocked. The settings are only applied when it is set to Locked again. At this point, the controller checks the functions set and compares them with the input and output settings. Important settings can then no longer be changed unless the configuration is unlocked again.

3. Select Configuration lock

Press the blue field with the text **Locked**

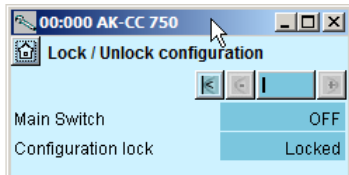

4. Select Unlocked



System setup

1. Go to Configuration menu



2. Select System setup

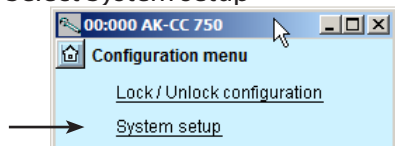

3. Set system settings

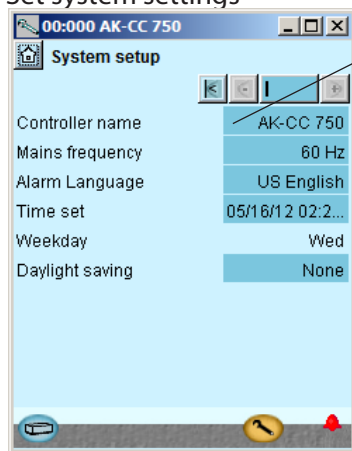

General

All system settings can be changed by pressing in the blue field with the setting and then indicating the value of the required setting.

3-

Controller name

In the first field you enter a name for what the controller will be controlling.

Main frequency

Set frequency.

Alarm language

Select the language that alarm text should be displayed in here. Alarm text can be in a different language to the operating language.

Clock

When the time is set the PC's time can be transferred to the controller. When the controller is connected to a network, date and time will automatically be set by the system unit in the network. This also applies to change-over Daylight saving.

Set plant type

1. Go to Configuration menu

2. Select plant type

Press the line **Select plant type**.

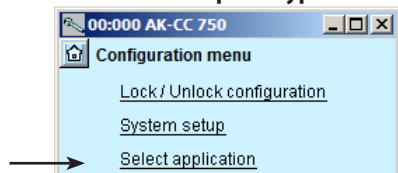

3. Set plant type

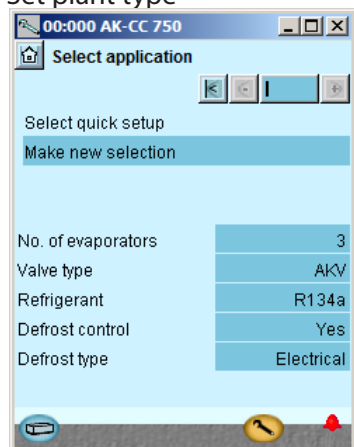

When the installation type is to be configured, it can be done in two ways:
Either one of these two

In the example, we have decided to use the second method. Here we select:

- 3 evaporators
- AKV valve
- Refrigerant = R134a
- Defrost
- Defrost = electric

3-

Select pre-configured application

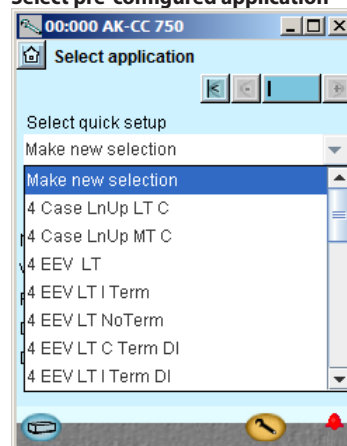

This setting give a choice between a number of predefined combinations, which at the same time determine the connection points.

At the end of the manual there is an overview of the options and connection points.

After configuration of this function, the controller will shut down and restart. After the restart, a large number of settings will have been made. These include the connection points. Continue with the settings and check the values.

If you change some of the settings, the new values will come into force.

Number of evaporators

Select the number of evaporators that you want the controller to regulate.

Valve type

Select the relevant type of valve here.
Either AKV valve or solenoid valve (at thermostatic expansion valve).

Refrigerant

Here you can select from a range of pre-defined refrigerants. If you cannot find the refrigerant you want in the list, select "User-defined". You can then set 3 constants which represent the refrigerant. You can obtain these 3 constants from Danfoss.

Defrost control

Select whether you want the evaporators to regulate with defrost.

Defrost type

You can select either natural defrost or electrical defrost, hotgas defrost or warm brine defrost.

4. Other settings

After the selection of application we will go through the other setup displays to check whether changes will have to be made on some of the predefined settings.

In our example we have to select a refrigerant, (which is done on the screen shown above) and we must add external start/stop settings (which is done in the subsequent "Common functions" screen).

- **Check the settings opposite the individual functions**

Definition of thermostat

1. Go to Configuration menu
2. Select Common control

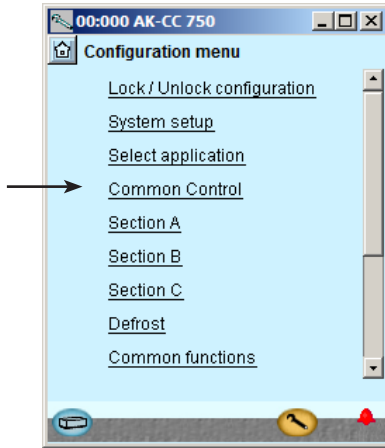

The setup menu has now changed. It now shows more settings all of which are based on the selected plant type. For example, earlier we selected 3 evaporators. This means that 3 sections are now displayed.

3. Select functions for thermostat

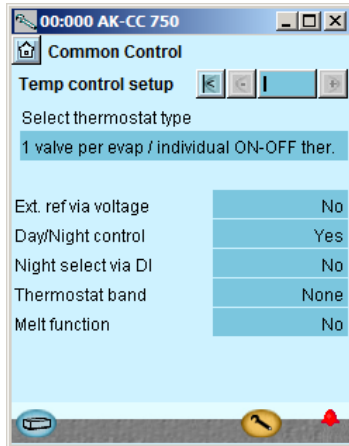

- In our example we select:
- On/off thermostat
 - Individual thermostat on each section
 - Night setback
 - No melt function, as this is a frost appliance

The settings are shown here in the display.

Depending on your settings, further settings may then be available for the selected functions.

This list in the right-hand column contains all the possible functions that may be made available in one way or another.

If you want to know more about the individual functions than the brief description below, you will find additional information in Chapter 5 of the manual.

3 - Thermostat type

Choose from the following thermostat functions:

- 1 valve for all /common ON-OFF thermostat
Here, only one valve is used for all evaporators. The temperature is controlled by an ON/OFF thermostat on the basis of the settings in the A section.
- 1 valve per evap/ common ON/OFF thermostat
Here, one valve per evaporator is used. The temperature is controlled in all evaporator sections by an ON/OFF thermostat on the basis of the settings in the A section.
- 1 valve per evaporator / individual ON/OFF thermostat
Here, one valve per evaporator is used. The temperature is controlled individual by ON/OFF in each evaporator section.
- 1 valve per evaporator /individual modulating thermostat
Here, one valve per evaporator is used. The temperature is controlled individually in each evaporator section according to a modulating principle

External reference via voltage

Select whether to use an external voltage signal for displacement of the thermostat reference.

Offset at max. signal

Offset value at max. signal (5 or 10V).

Offset at min. signal

Offset value at min. signal (0,1 or 2V).

Day/ night control

Select whether the thermostat temperature is raised for night operation (Night offset values must be set in the individual sections and in Kelvin)

Night displacement via DI

Select whether night displacement is to take place with an input signal. (Alternatively, the signal can be generated from the internal weekly schedule or from the system administrator via data communication.)

Thermostat band

Select whether you want the thermostat to switch between two reference settings (the values can be set in the individual sections. (Cutout 2))

Select whether the switch should be initialised by pulse pressure or by a switch.

Thermostat band select via DI

Select whether the reference is to be made with a signal on a DI input.

Melt function

Select whether you want the controller to perform a melting function

Melt interval

Set the time period between two melting intervals

Melt time

Set the melting time

Definition of sections

1. Go to Configuration menu

2. Select Section A

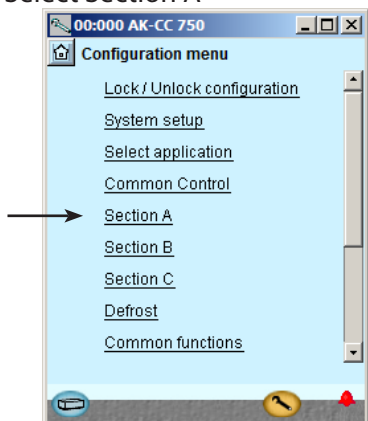

3. Set values for thermostat A

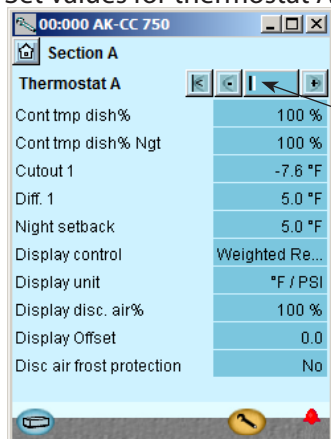

Press the + -button to go on to the next page

4. Set values for alarm thermostat

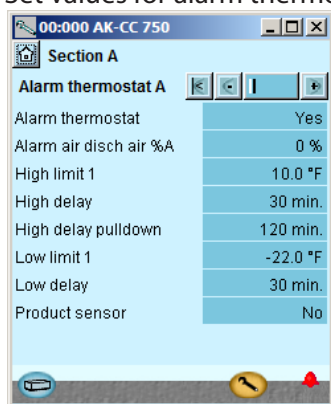

5. Define the other sections

Example:
The settings are shown here in the display.

There are several pages, one after the other.

The black bar in this field tells you which of the pages is currently displayed.

Move between the pages using the + and - buttons.

Repeat the steps above for each section.

In our example, the settings are the same for all 3 sections.

3 - Thermostat temperature

In the case of a common thermostat: Choose which sensors are to be included in temperature regulation: Weighted S3A-S4A, lowest of all S3s, average of all S3s, highest of all S3s, lowest of all S4s, average of all S4s or highest of all S4s.

Air temperature S4 (discharge)Day

Sensor selection for the thermostat during day operation
At 100%, only S4 is used. At a lower value, S3 is also used in the thermostat function. At 0%, only S3 is used in the thermostat function.

Air temperature S4 (discharge) Night

As above, but for night operation

Cutout 1

The thermostat's cutout temperature - Thermostat band 1

Differential 1

Differential on regulation according to Thermostat band 1

Cutout 2

The thermostat's cutout temperature - Thermostat band 2

Differential 2

Differential on regulation according to Thermostat band 2

Night setback

Displacement of the reference during night operation

Display control

Select whether you want to connect to display type EKA 163B / EKA 164B to indicate the appliance temperature for section A. Settings are: non, weighted S3/S4 or product temperature sensor.

Display unit

Select whether you want temperatures and pressure displayed in SI units (°C) or US units (°F)

Display S4 (discharge) %

Sensor selection for the temperature shown on the display
At 100%, only S4 is used. At a lower value, S3 is also used. At 0%, only S3 is displayed.

Display Offset

Any offset for the display readout

S4 (discharge) Frost protection

Select whether an alarm is triggered in the case of low S4 temperature

S4 (discharge) Frost limit

Set the alarm level for the S4 sensor.

4-

Alarm thermostat

Select whether you want to activate the alarm thermostat

Alarm air S4 (discharge) %

Set the weighting of the S4 sensor for the alarm thermostat

High alarm limit 1

Alarm limit for high temperature alarm, thermostat band 1

High alarm limit 2

Alarm limit for high temperature alarm, thermostat band 2

High delay

Time delay for a high temperature alarm

High delay pulldown

Time delay during pull-down and after defrost

Low alarm limit 1

Alarm limit for a low temperature alarm, thermostat band 1

Low alarm limit 2

Alarm limit for a low temperature alarm, thermostat band 2

Low delay

Time delay for a low temperature alarm

Product sensor

Indicate whether a product sensor is used

High alarm limit 1

Alarm limit for high product temperature, thermostat band 1

High alarm limit 2

Alarm limit for high product temperature, thermostat band 2

High delay

Time delay for a high product temperature alarm

High delay pulldown

Time delay during pull-down and after defrost

Low alarm limit 1

Alarm limit for a low product temperature, band 1

Low alarm limit 2

Alarm limit for a low product temperature, band 2

Low delay

Time delay for a low product temperature alarm

Definition of defrost functions

1. Go to Configuration menu

2. Select Defrost function

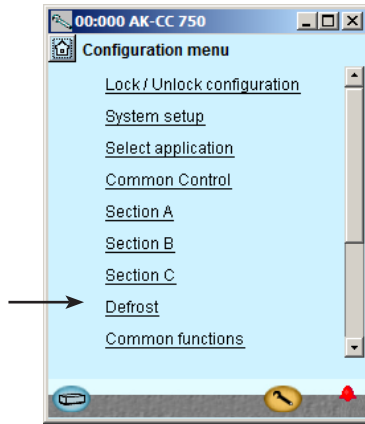

3. Set functions

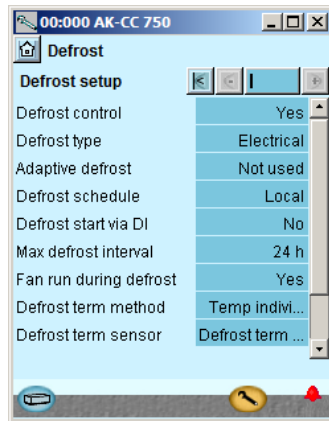

Example:
The settings are shown here in the display.

If the controller's internal defrost schedule is used to start defrost, the start times must be set using the everyday user interface. See page 61.

3 -

Defrost control

Select whether you want the controller to control defrost.

Defrost type

Choose a defrost method (electric / natural / hot gas or warm brine)

Adaptive defrost

The function can be set to: "Not used"/"Monitor ice"/"Permit cancellation of defrost for day (Skip day)"/"Skip day/night"/"Full adaptive defrost".

Min. time between defrosts

Set how often defrosting is allowed.

Pc signal for AD (Adaptive defrost)

Choose which signal is to be followed: an internal signal (Local) or a signal via data communications (Network).

Defrost schedule

Choose which schedule is to be followed: an internal schedule or an external schedule from the system unit

Defrost start via DI

Select whether defrost should start when a signal is received on a DI input

Max. defrost interval between defrosts

Defrost is started at the set interval if it is not started using other methods (manual start, weekly schedule, network, DI). If defrost is started using a schedule, "Max. interval" should be set to a value greater than the longest period between two defrosts in the schedule.

Fan run during defrost

Specify whether the fans should be on during defrost.

Defrost term method

Define whether defrost is to be concluded with:

- Time
- Temperature individual in each section
- Temperature common for all sections
- DI signal individual for each section
- DI signal common for all sections

Defrost term sensor

Select the sensor that you want to give the signal for defrost stop

Stop temperature A, B, C, D

Set the temperature at which defrost should stop

Max. defrost time

Defrost will stop after this period, even if the defrost temperature has not been reached

Min. defrost time

Defrost will run in this period, even if the defrost temperature are reached

Pump down delay

Time delay before defrost when the fluid injection stops and the evaporator is emptied of liquid

Drip off delay

Time delay after defrost to allow water droplets to drip off the evaporator before refrigeration is restarted

Drain delay

Delay in which the drain valve is kept open in order to ensure pressure equalisation

Fan delay

Maximum permitted fan delay following defrost

Fan start temperature

The fans will start when the temperature at the defrost sensor falls below this value.

Drip tray heater

Set whether there is to be heating in the drip tray

Drip tray heater delay

Set heating time (time from the point at which defrost stops)

Max. Hold time

Maximum hold time that the controller will wait for the signal to restart refrigeration (used with coordinated defrost)

Show advanced adaptive defrost

All settings for this function are expert settings.

Definition of common functions

1. Go to Configuration menu

2. Select Common functions

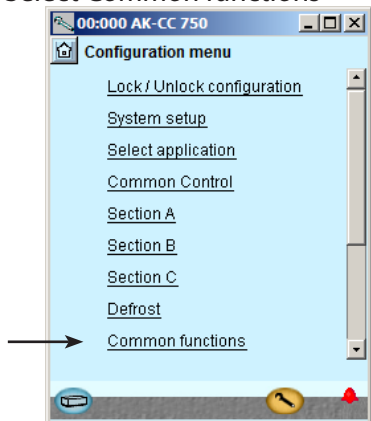

3. Set functions in the first display

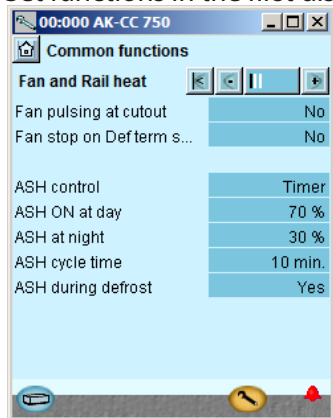

Press the +-button to go on to the next page

4. Set the functions in another display

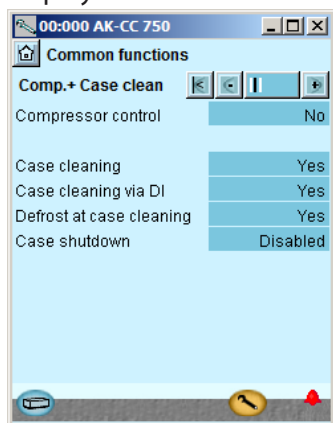

Press the +-button to go on to the next page

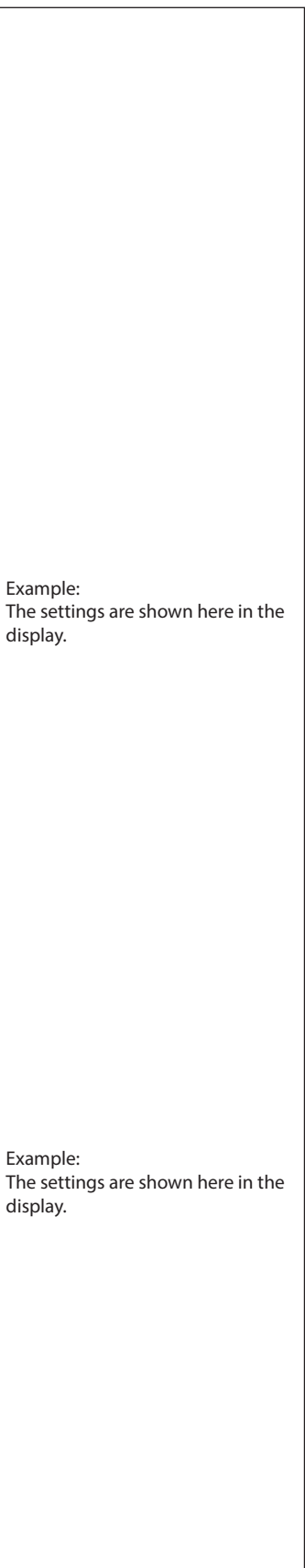

Example:
The settings are shown here in the display.

Example:
The settings are shown here in the display.

3-

Common functions for fans and rail heat (antisweat heat)

Fan pulsing at cutout

Select whether you want the fans to pulse during the thermostat's cutout period. Pulsing can be restricted to either: "night operation only" (appliance with night cover) or "both day and night operation" (cold storage room)

Fan ON %

Set how long the fans should be ON during pulsing. Enter as a percentage of the pulse period.

Fan duty cycle

Set the fan's operation period for pulsing

Fan stop on S5

Select whether the fans should stop if the S5A temperature is too high. Used to stop the fans if refrigeration is not working.

Fan stop temp.

Set the temperature limit for the S5A sensor at which the fans stop

ASH control

Select whether to use pulsing/rail heat control. Non/Timer or Dew point.

ASH ON at day

Set how long the rail heat should be ON for during day operation. Enter as a percentage of the rail heat pulse period

ASH at night

Set how long the rail heat should be ON for during night operation. Enter as a percentage of the rail heat pulse period.

Dew point max. limit

At a dew point above this value, rail heat is 100%.

Dew point min limit

At a dew point below this value, rail heat is controlled with the next setting "Min ON".

ASH Min ON%

Period in which the dew point is below the min. limit.

ASH cycle time

Rail heat pulse period.

ASH during defrost

Select whether you want the rail heat to be OFF during defrost.

4-

Common functions for compressor and case cleaning

Compressor control

Select whether you want to use compressor control

Min. ON time

Set the minimum runtime for the compressor once it has started

Min. Restart time

Set the minimum time between the compressor stopping and restarting

Runtime total

Set any runtime for the compressor

Case cleaning

Select whether you want an case cleaning function

Case cleaning via DI

Select whether to use a digital input to activate the case cleaning function. Alternatively the case cleaning function can be activated from the display or using a parameter setting

Defrost at case cleaning

Select whether to activate the case cleaning function with a defrost sequence. Used for frost appliances to achieve fast defrost of the appliance before cleaning.

Appliance shutdown

Select function for light and fans when appliance shut down

5. Set the functions in the third display

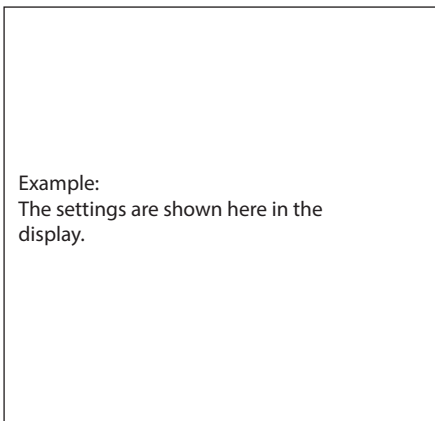
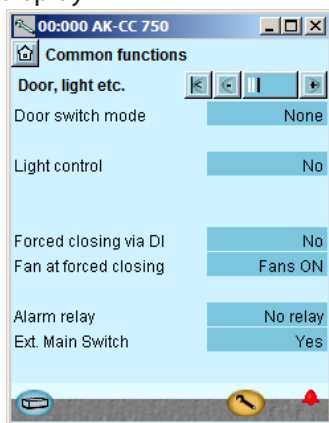

Example:
The settings are shown here in the display.

5-

Common functions for door, light etc.

Door switch mode

Select the function of any door switch. The door switch can be used in one of the following two ways:

- Alarm only, if the door has been left open for too long
- Stop refrigeration and fans when the door is open, along with an alarm if the door has been left open for too long

Light off delay

Set how long the light should remain on after the door has been closed (requires a light control to be set up and controlled via the door switch)

Restart refrig. delay

Set how long the door may be open before refrigeration and fans are restarted. Prevents exposure of the products to too high a temperature if someone forgets to close the door.

Door alarm delay

If the door has been open for more than the time delay set here, a door alarm is triggered

Light control

Select whether the light should be controlled by a door switch, a day/night signal or by a signal via data communication

Light at Main SW = Off

Choose whether the light is to be switched off when the main switch is set to off, or if the light is to follow the standard light control.

Control of Blinds control

Set whether the blinds are to be controlled by a relay.

Open/close blinds via DI

Set whether the controller is to receive a signal which activates the blinds. This must be a pulse signal.

Forced closing via DI

Select whether a digital input is used for the forced closing of injection

Fan at forced closing

Select whether or not you want the fans to operate during forced closing.

Alarm relay

Select the alarm relay function.

The alarm relay must be activated by alarm priorities:

- low to high
- low to medium
- high

The alarm relay can be activated either by all alarm priorities from low to high or only by high priority alarms

Ext. main switch

Select whether you want a main switch via a digital input. When the main switch is set to Off, all regulation is stopped, all outputs are set to standby and all alarms are cancelled.

Configuration of inputs and outputs

1. Go to Configuration menu

2. Select I/O configuration

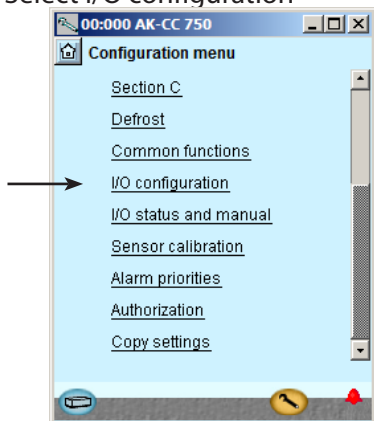

The following displays will depend on the earlier definitions. The displays will show which connections the earlier settings will require. The tables are the same as shown earlier.

- Digital outputs
- Digital inputs
- Analog outputs
- Analog inputs

Important!
An AKV function can only be set for module 1 and only for points 12, 13, 14 and 15

3. Configuration of Digital outputs

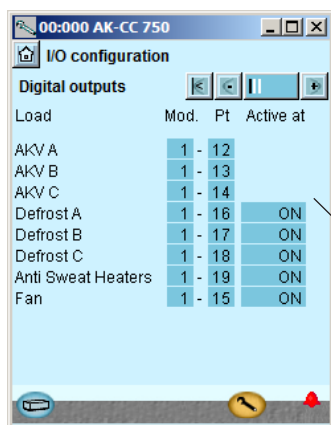

Load	Output	Mod- ule	Point	Active at
AKV A	DO1	1	12	-
AKV B	DO2	1	13	-
AKV C	DO3	1	14	-
Fan	DO4	1	15	ON
Defrost A	DO5	1	16	ON
Defrost B	DO6	1	17	ON
Defrost C	DO7	1	18	ON
Anti sweat heaters	DO8	1	19	ON

3 - Outputs

The possible functions are the following:
AKV or solenoid valve
Defrost (el/hot gas)
Common defrost
Suction line valve
Drain valve
Drip tray heat
Night blind
Compressor
ASH
Light
Fan
Alarm

We set up the controller's digital outputs by keying in which module and point on this module each one of these has been connected to. We furthermore select for each output whether the load is to be active when the output is in pos. **ON** or **OFF**.

Press the +-button to go on to the next page

4. Setup On/off input functions

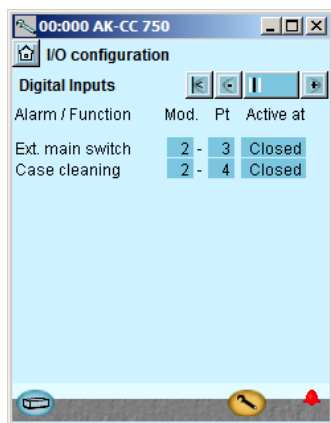

Function	Input	Mod- ule	Point	Active at
External start/stop	AI3	2	3	Closed
Case cleaning (pulse pressure)	AI4	2	4	Closed

4 - Digital inputs

The possible functions are the following:
Night displacement
Door alarm
Forced closing
Ext. Main switch
Thermostat band
Defrost start
Case cleaning
Appliance shutdown
Open / close Night blinds

We set up the controller's digital input functions by keying in which module and point on this module each one of these has been connected to. We furthermore select for each output whether the function is to be active when the output is in pos. **Closed** or **Open**.

Press the +-button to go on to the next page

5. Configuration of Analog Input signals

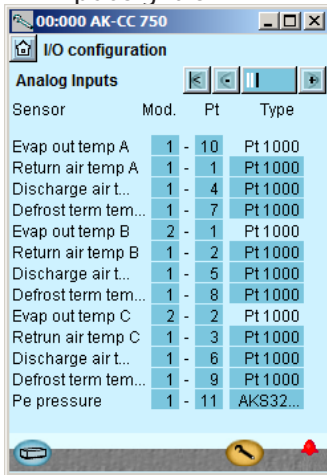

Sensor	Input	Module	Point	Type
Air temperature S3 A	AI1	1	1	Pt 1000
Air temperature S3 B	AI2	1	2	Pt 1000
Air temperature S3 C	AI3	1	3	Pt 1000
Air temperature S4 A	AI4	1	4	Pt 1000
Air temperature S4 B	AI5	1	5	Pt 1000
Air temperature S4 C	AI6	1	6	Pt 1000
Defrost sensor S5 A	AI7	1	7	Pt 1000
Defrost sensor S5 B	AI8	1	8	Pt 1000
Defrost sensor S5 C	AI9	1	9	Pt 1000
Gas temperature -S2 A	AI10	1	10	Pt 1000
Evaporating pressure - P0	AI11	1	11	AKS32R-12
Gas temperature -S2 B	AI1	2	1	Pt 1000
Gas temperature -S2 C	AI2	2	2	Pt 1000

We set up the analog inputs for the sensors.

5 - Analog inputs

The possible signals are the following:

Temperature sensors:
S2 Evaporating temp. (A,B,C,D)

S3 Air temp. before evaporator (A,B,C,D)

S4 Air temp. after evaporator (A,B,C,D)

S5-1 Defrost sensor (A,B,C,D)

S5-2 Defrost sensor (A,B,C,D)

Product temperature (A,B,C,D)

Setting:
• Pt1000
• PTC 1000

Pressure transmitters:

P0 evaporator pressure
Pc Cond. pressure

Paux 1 - 3

Setting:

- AKS 32, -1 – 6 Bar
- AKS 32R, -1 – 6 Bar
- AKS 32, -1 – 9 Bar
- AKS 32R, -1 – 9 Bar3
- AKS 32, -1 – 12 Bar
- AKS 32R, -1 – 12 Bar
- AKS 32, -1 – 20 Bar
- AKS 32R, -1 – 20 Bar
- AKS 32, -1 – 34 Bar
- AKS 32R, -1 – 34 Bar
- AKS 32, -1 – 50 Bar
- AKS 32R, -1 – 50 Bar
- AKS 2050, 1 – 59 Bar
- AKS 2050, -1 – 99 bar
- AKS 2050, -1 – 159 bar

Voltage signals for reference displacement:

Ext. Ref. Signal

Setting:

- 0 - 5 V,
- 1 - 5 V,
- 0 -10 V,
- 2 - 10 V

Set alarm priorities

1. Go to Configuration menu

2. Select Alarm priorities

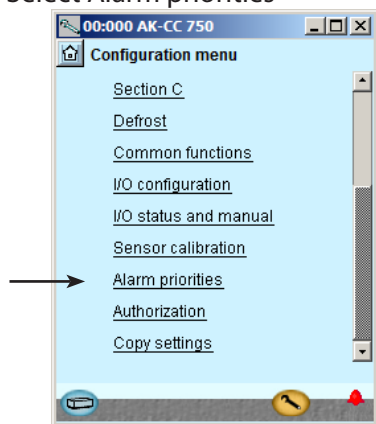

3. Set priorities for Temperature alarms

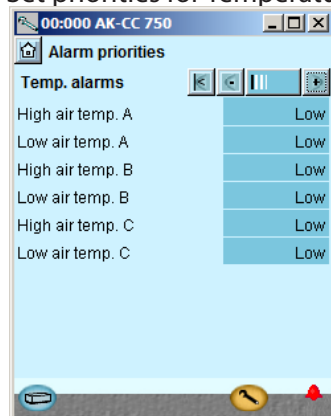

Press the +-button to go on to the next page

4. Set Alarm priorities for sensor error

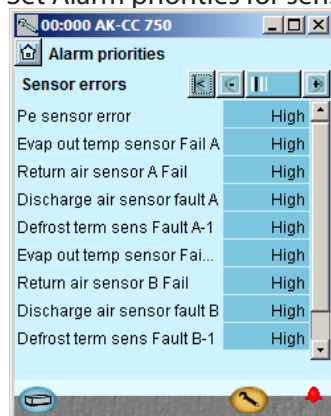

Press the +-button to go on to the next page

Very many functions have an alarm connected.

Your choice of functions and settings has connected all the relevant alarms that are current. They will be shown with text in the three pictures.

All alarms that can occur can be set for a given order of priority:

- "High" is the most important one
- "Log only" has lowest priority
- "Disconnected" gives no action

The interdependence between setting and action can be seen in the table.

Setting	Log	Alarm relay selection			Net-work	AKM-dest.
		Non	High	Low - High		
High	X		X	X	X	1
Medium	X			X	X	2
Low	X			X	X	3
Log only	X					4
Discon- nected						

In our example we select the settings shown here in the display

In our example we select the settings shown here in the display

5. Set Alarm priorities for "Various alarms"

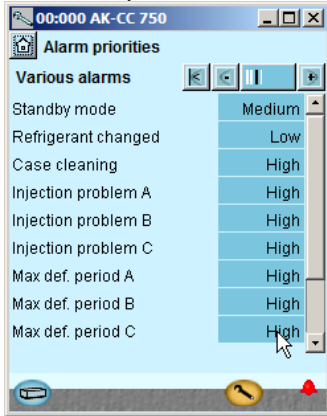

In our example we select the settings shown here in the display

Lock configuration

1. Go to Configuration menu

2. Select Lock/Unlock configuration

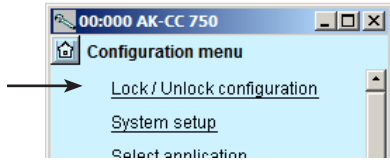

3. Lock Configuration

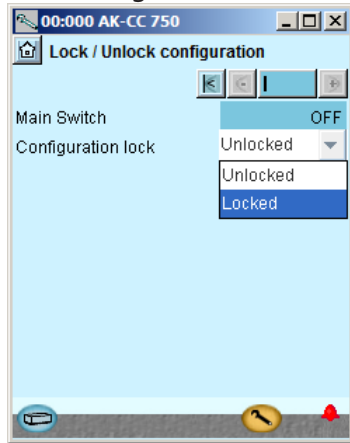

The controller will now make a comparison of selected functions and define inputs and outputs. The result can be seen in the next section where the setup is controlled.

Press in the field against **Configuration lock**.

Select **Locked**.

The setup of the controller has now been locked. If you subsequently want to make any changes in the controller's setup, remember first to unlock the configuration.

Check configuration

1. Go to Configuration menu

2. Select I/O configuration

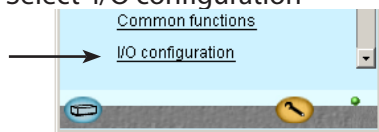

This control requires that the setup is locked

(Only when the setup is locked are all settings for in- and outputs activated.)

3. Check configuration of Digital Outputs

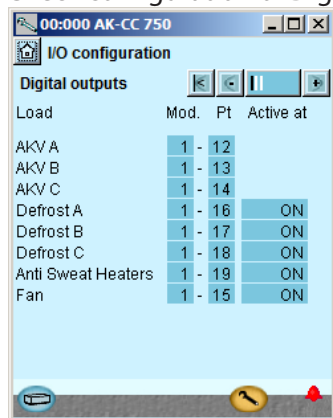

The setup of the digital outputs appears as it is supposed to according to the wiring made.

An error has occurred, if you see the following:



A **0 - 0** next to a defined function. If a setting has reverted to 0-0, you must control the setup again.

This may be due to the following:

- A selection has been made of a combination of module number and point number that does not exist.
- The selected point number on the selected module had been set up for something different.

The error is corrected by setting up the output correctly.

Remember that the setup must be unlocked before you can change module and point numbers..

Press the + -button to go on to the next page

4. Check configuration of Digital Inputs

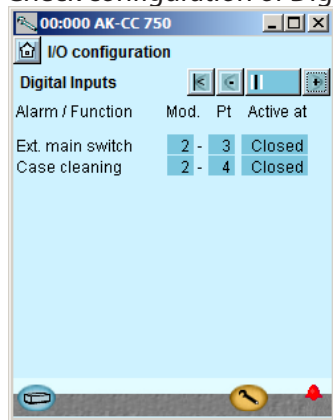

The setup of the digital inputs appears as it is supposed to according to the wiring made.



The settings are shown on a **RED** background. If a setting has turned red, you must control the setup again.

This may be due to the following:

- The input or the output has been set up; but the setup has later been changed so that it should no longer be applied.

The problem is corrected by setting **module number to 0 and point number to 0.**

Remember that the setup must be unlocked before you can change module and point numbers.

Press the + -button to go on to the next page

5. Check configuration of Analog Outputs

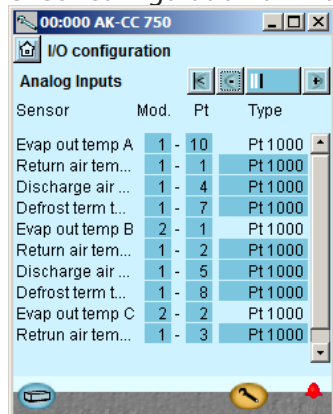

The setup of the Analog inputs appears as it is supposed to according to the wiring made.

Check of connections

1. Go to Configuration menu

2. Select I/O status and manual

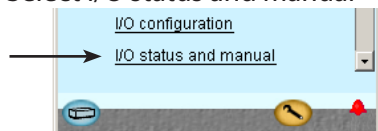

3. Check Digital Outputs

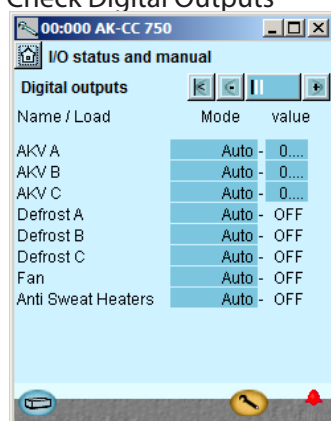

Press the +-button to go on to the next page

4. Check Digital Inputs

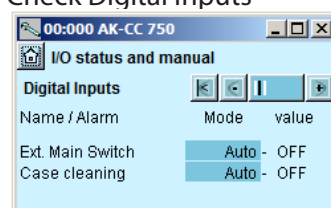

Press the +-button to go on to the next page

5. Check Analog inputs

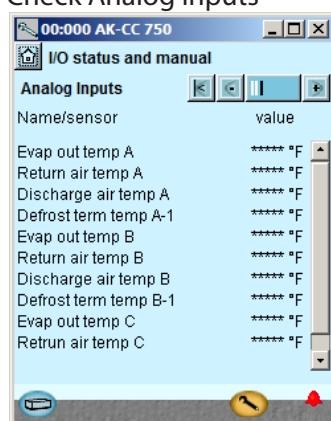

Before the control is started we check that all inputs and outputs have been connected as expected.

This controls requires that the setup is locked

By means of the manual control of each output it can be checked whether the output has been correctly connected.

- AUTO** The output is controlled by the controller
- MAN OFF** The output is forced to pos. OFF
- MAN ON** The output is forced to pos ON

Activate the various functions (e.g. the main switch).
Check that the controller registers the activation – i.e. whether the ON/OFF value is changed in the last column.
Check the other digital inputs in the same way.

Check that all sensors show sensible values.

In our case we have no value. This may be due to the following:

- The sensor has not been connected.
- The sensor is short-circuited/interrupted
- The point or module number has not been set up correctly.
- The configuration is not locked.

Check of settings

1. Go to the overview

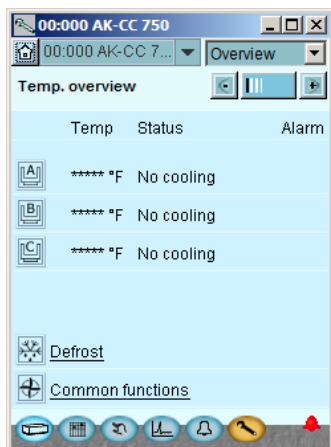

2. Select evaporator A



3. Settings for thermostat

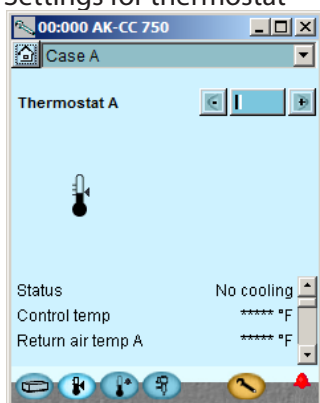

4. Move on with the next display for the section. Here the alarm thermostat

Press the blue overview button at the bottom left of the display.



5. Settings for alarm thermostat

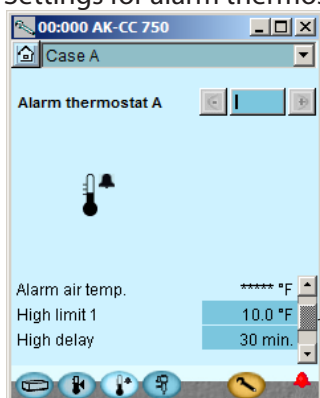

Before the control starts, we check that all the settings are as they should be.

The overview display will now show one line for each of the general functions. Behind each icon there is a number of displays with the different settings. It is all these settings that have to be checked.

Remember the settings at the bottom of the pages – the ones that can only be seen via the “Scroll bar”.

Page 2 shows a summary of the temperature sequence over the past 24 hours.

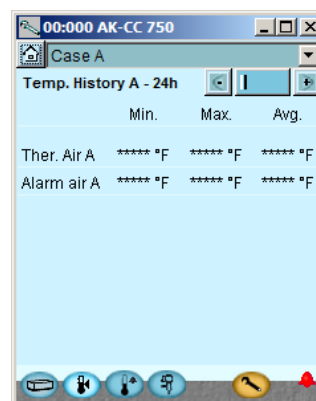

Remember the settings at the bottom of the pages – the ones that can only be seen via the “Scroll bar”.

6. Move on with the next display for the section. Here the expansion valve function

Press the blue overview button at the bottom left of the display..



7. Settings for the injection function

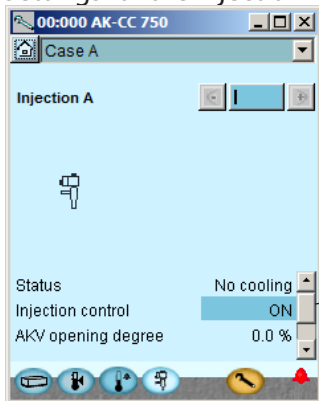

Remember the settings at the bottom of the pages – the ones that can only be seen via the "Scroll bar".

The settings can be reviewed in the same way as for section A.

8. Repeat for Evaporator B and later again for C



9. Go to defrost display

Press the blue overview button at the bottom left of the display and then press the defrost symbol



10. Settings for defrost

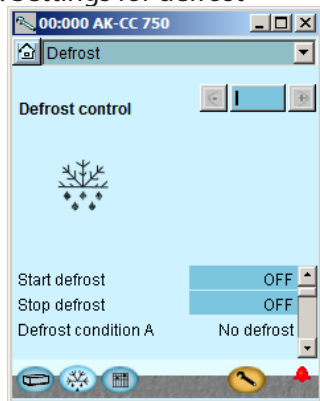

Remember the settings at the bottom of the pages – the ones that can only be seen via the "Scroll bar".

11. Go to defrost schedule

Press the **schedule** button to continue to the defrost schedule



12. Setup defrost schedule

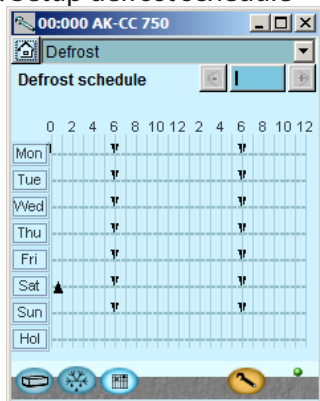

In our example, the defrost schedule is set to defrost twice a day.

13. Press a weekday and set the times for the various defrost starts.

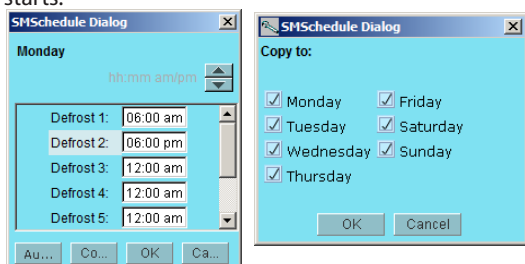

Use the copying functions if there are several days with identical defrosts.

The end result with two defrosts per 24 hours can be seen here above.

14. Go to common functions

Press the blue overview button at the bottom left of the display and then on common functions

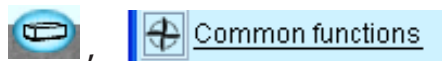

15. The settings for the common functions

Go through the individual functions.

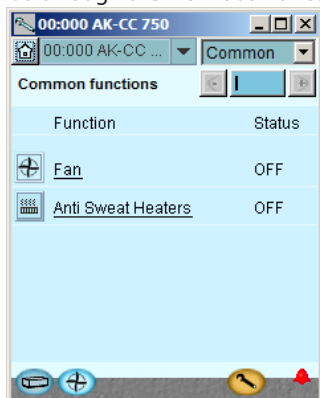

16. The controller setup has been completed.

Installation in network

1. Set the address (here, for example 3)

Turn the right-hand address switch so that the arrow will point at 3.

The arrow of the two other address switches must point at 0.

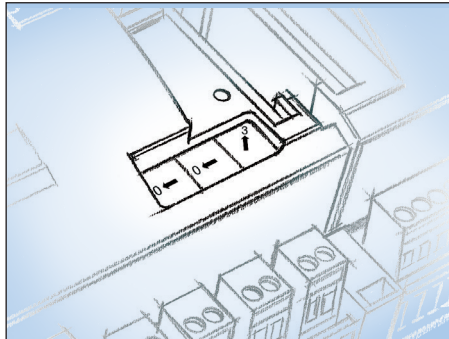

2. Push the Service Pin

Press down the service pin and keep it down until the Service Pin LED lights up.

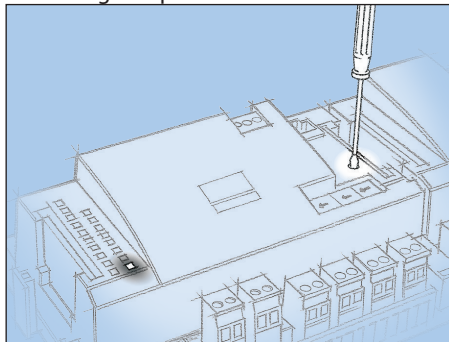

3. Wait for answer from the system unit

Depending on the size of the network it may be up to one minute before the controller receives an answer as to whether it has been installed in the network.

When it has been installed the Status LED will start to flash faster than normal (once every half second). It will continue with this for about 10 minutes

4. Carry out new login via Service Tool



If the Service Tool was connected to the controller while you installed it in the network, you must carry out a new login to the controller via the Service Tool.

Requirement to the system unit

The system unit must be a AK-SC 255, 355 or SM 850. It is capable of handling up to 120 AK controllers.

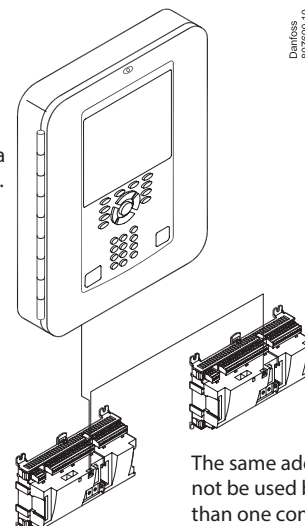

The controller has to be remote-monitored via a network. In this network we assign address number 3 to the controller.

The same address must not be used by more than one controller in the same network.

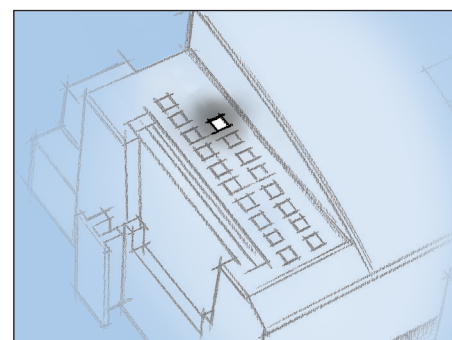

If there is no answer from the system unit

If the Status LED does not start flashing faster than normal, the controller has not been installed in the network. The reason for this may be one of the following:

The controller has been assigned an address out of range

Address 0 cannot be used.

The selected address is already being used by another controller or unit in the network:

The address setting must be changed to another (vacant) address.

The wiring has not been carried out correctly.

The termination has not been carried out correctly.

The data communication requirements are described in the document: "Data communication connections to ADAP-KOOL® Refrigeration Controls" RC8AC.

First start of control

Check alarms

1. Go to the overview



Press the blue overview button at the bottom left of the display.

2. Go to the Alarm list



Press the blue button with the alarm bell at the bottom of the display.

3. Check active alarms

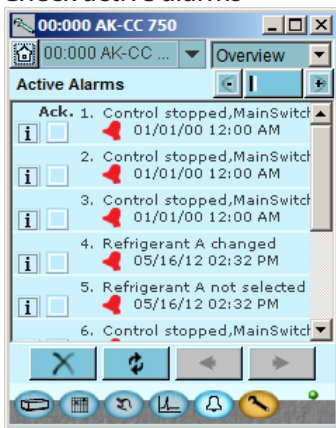

In our case, we have a series of alarms. We will tidy them up so that we only have those that are relevant.

4. Remove cancelled alarm from the alarm list



Press the red cross to remove cancelled alarms from the alarm list.

5. Check active alarm again

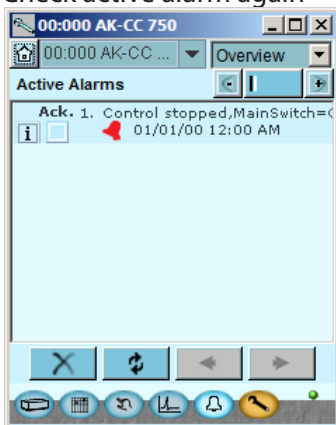

In our case an active alarm remains because the control has stopped. This alarm must be active when control has not started. We are now ready for the startup of control.

Please note that active plant alarms are automatically cancelled when the main switch is in pos. OFF. If active alarms appear when the control is started the reason for these should be found and remedied.

Start the control

1. Go to Start/Stop display



Press the blue manual control button at the bottom of the display.

2. Start control

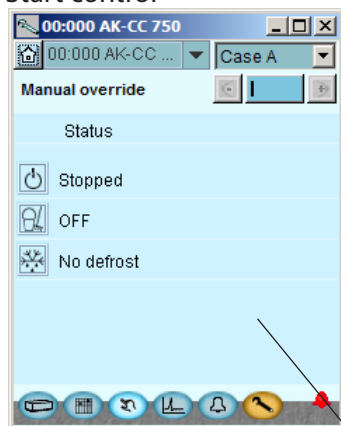

Press in the field against **Main switch**.
 Select **ON**.
 Press **OK**.

The controller will now start the controlling when the external function switch is also activated to ON.

If you wish to start an extra defrost cycle, it can be done via this display and also from the defrost screen.

Setup logs

1. Go to the overview



Press the blue overview button with the log symbol.

2. Log display

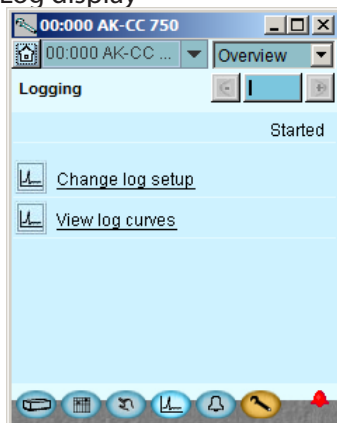

The top line gives access to definition of new logs and to changes of already established logs.

The next line enables you to see a selection of the defined logs

3. New logs

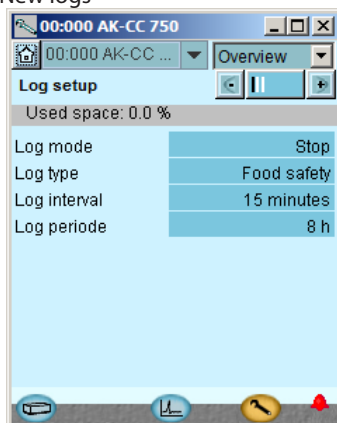

Here is the start display for new logs

Start by defining which type of log has to be defined



Press the +-button to go on to the next page

4. Selection of parameters

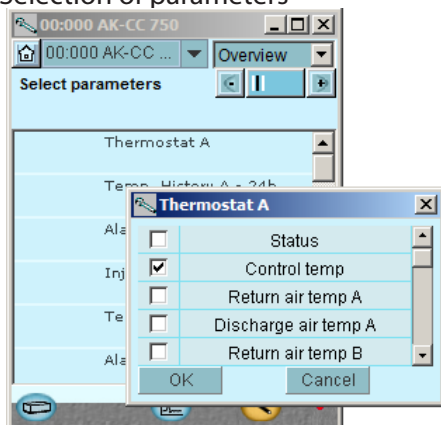

Here it is determined which parameters have to be included in the setup of data. Select a function here, then a parameter, and finish with OK.



Press the +-button to go on to the next page

5. Log survey

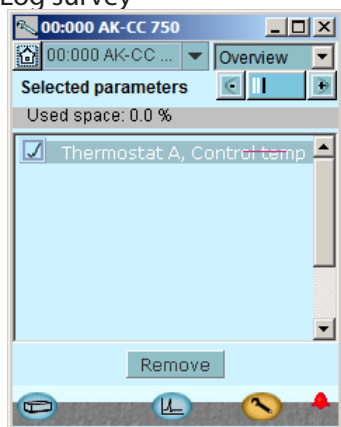

Here is the survey of all the parameters that are collected in the log.

If a parameter has to be removed from the log collection, you must select the parameter and then press Remove.

If a parameter has to be added it is done in accordance with the earlier display

A LOG CAN ONLY BE DISPLAYED IF:

- THE CLOCK HAS BEEN SET AND
- THE CONFIGURATION IS LOCKED

6. Start the log collection

Move to the first of the three displays and start the log collection

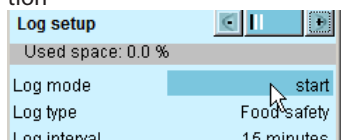

Manual defrost

1. Go to Configuration menu



2. Select defrost



3. Start defrost

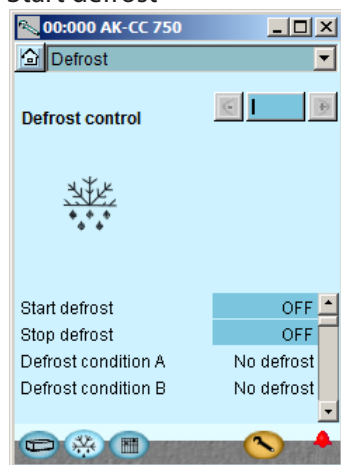

If you want to carry out manual defrost, proceed as follows.

Activate

5. Regulating functions

This section describes how the different functions work

Introduction

Application

AK-CC 750 controllers are complete regulating units which together with valves and sensors constitute complete evaporator controls for refrigeration appliances and freezing rooms within commercial refrigeration.

Generally speaking they replace all other automatic controls containing, inter alia, day and night thermostats, defrost, fan control, rail heat control, alarm functions, light control, etc.

The controller is equipped with data communication and is operated via a PC.

In addition to evaporator control the controller can give signals to other controllers about the operating condition, e.g. forced closing of expansion valves, alarm signals and alarm messages.

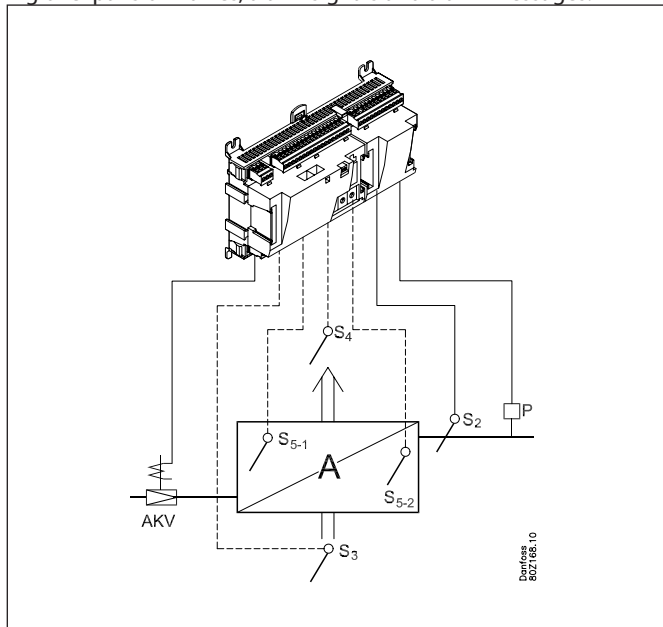

The controller's main function is to control the evaporator so that the system constantly operates with the most energy-friendly refrigeration.

A specific function for registration of the need for defrost will adapt the number of defrosts so that no energy is wasted on unnecessary defrosts and subsequent cooling-down cycles.

Among the different functions can briefly be mentioned:

- Control of up to four evaporator sections
- Electronic injection with AKV valve
- ON/OFF or modulating temperature control
- Weighted thermostat and alarm thermostat
- Defrost on demand based on evaporator capacity
- Appliance cleaning function
- Appliance shutdown via data communication

The complete survey of controllers and functions can be seen in the manual chapter 2 in section "Design of a evaporator control".

Examples

The controller has been designed to control one of the following four plant types.

Through the programming you determine which one.

Evaporator control of one, two, three or four evaporators

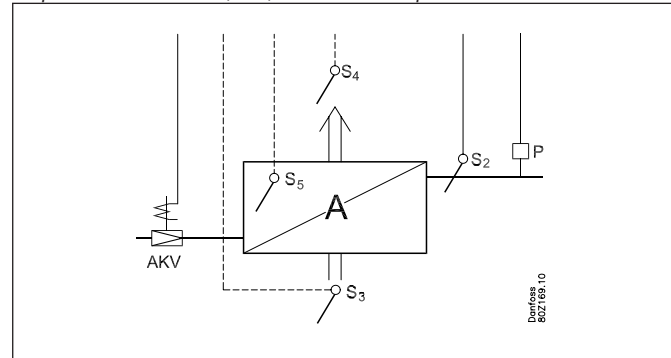

Control of cool or defrost room

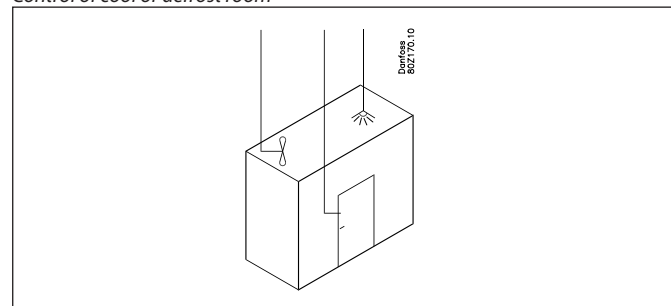

Control of cool or defrost appliance

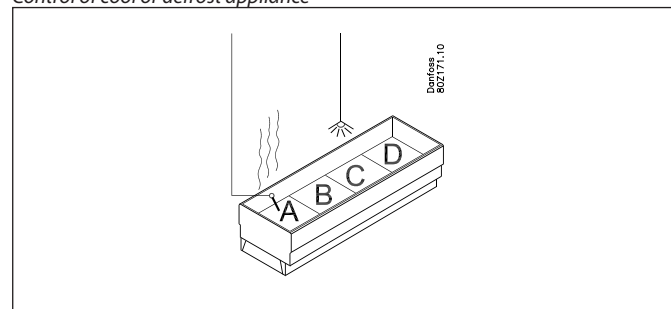

- The refrigerant is either regulated by means of:
 - expansion valve type AKV or
 - solenoid valve and thermostatic expansion valve

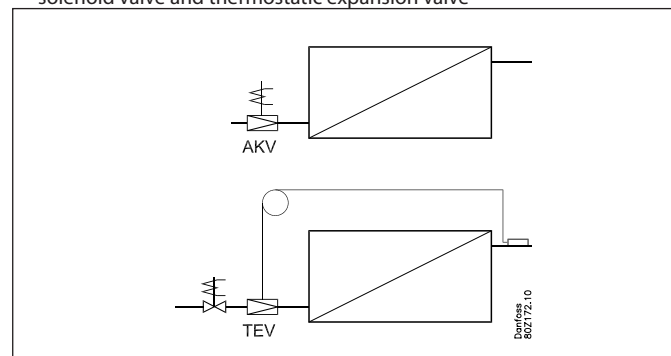

Thermostat function

Valve type and thermostat

Principle

Up to 4 valves can be connected to the controller; one for every solid state output.

It is possible to use electrically controlled expansion valves type AKV for regulation, or else injection can take place using thermostatic expansion valves (TEV) in which the temperature is regulated using solenoid valves in the liquid line (LLSV), e.g. Danfoss type EVR.

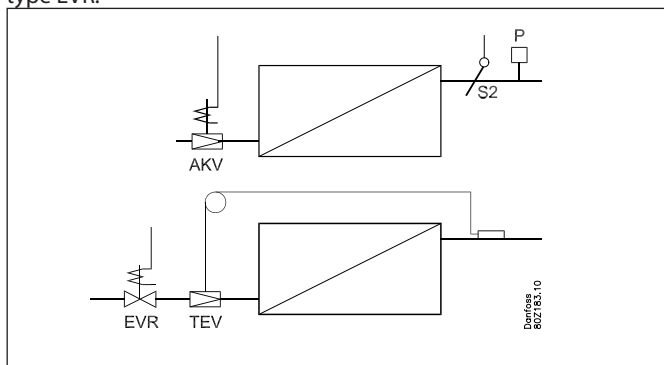

The thermostat function can be defined in different ways depending on which application it is used for. For example:

- regulation principle /
- what sensors are to be used /
- whether the user wishes to toggle between two temperature settings, etc.

It is necessary for at least one air sensor to be fitted for every evaporator section. This is applicable irrespective of which thermostat function is selected – including "no" thermostat. The thermostat's cut-out temperature also has to be set to the correct air temperature as this value is used by the injection function.

Thermostat type= ON/OFF

One common valve for all evaporators + common ON/OFF thermostat

A line up of refrigeration appliances which are to be regulated to the same temperature is a typical example.

The temperature is controlled according to the ON/OFF principle in accordance with the thermostat settings in section A.

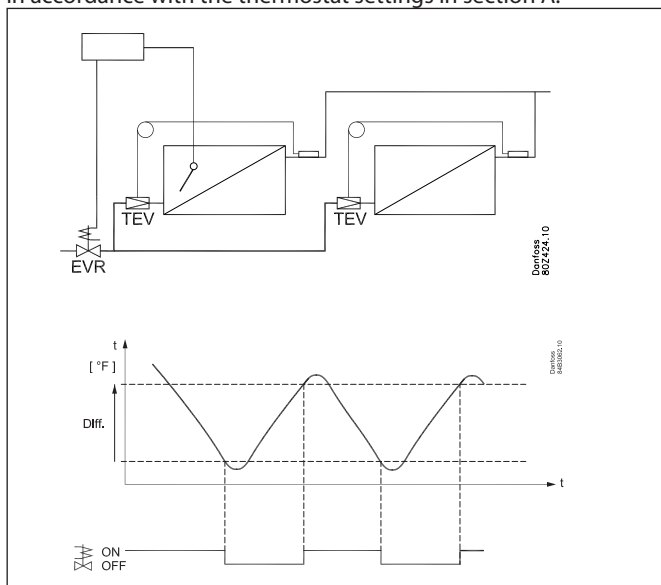

The thermostat can control the temperature via:

- a signal from the S3/S4 sensors in section A, or
- min/max or average temperatures in all the sections used (see the section on sensor selection).

AKV valve

This principle can also be used with electronic expansion valves type AKV; e.g. refrigeration appliances where one valve is used for two evaporators. These appliances are specially designed for this application as the evaporator area is divided over two refrigeration sections in order to achieve a consistent load over the two circuits.

One valve for every evaporator + common ON/OFF thermostat

Here, one valve is used per evaporator and the temperature is controlled according to the ON/OFF principle in accordance with the thermostat settings in section A

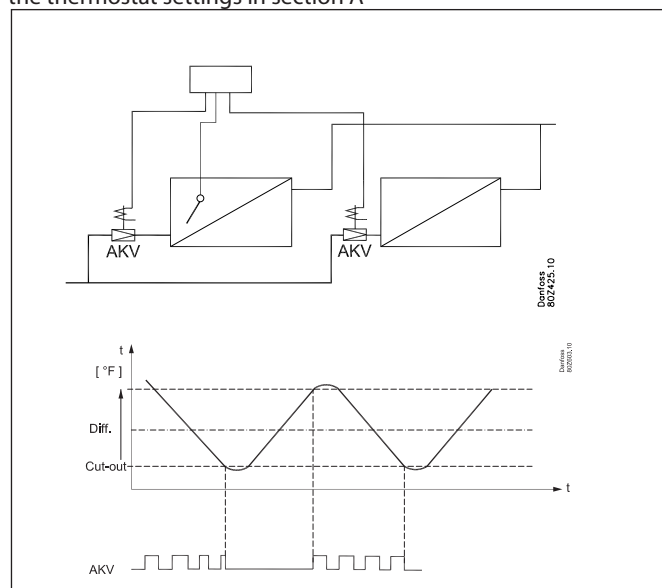

The thermostat can control the temperature via:

- a signal from the S3/S4 sensors in section A, or
- min/max or average temperatures in all the sections used (see the section on sensor selection).

One valve for every evaporator + individual ON/OFF thermostat
 Here, one valve is used per evaporator and the temperature is controlled individually in each evaporator section according to the ON/OFF principle.

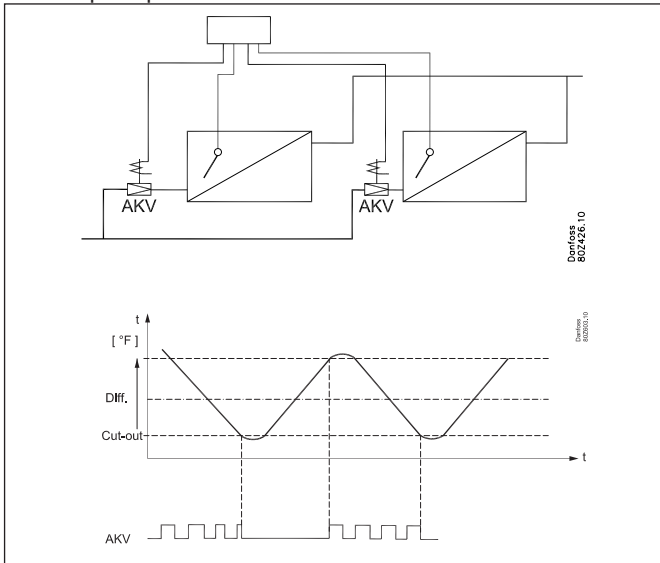

The thermostat in every section controls the temperature via the S3/S4 sensors in every section (where appropriate, see the section on sensor selection).

Thermostat type = Modulating

Modulating temperature regulation maintains a more constant temperature and also equalises the load on the system so that the compressors have better operating conditions.

- This function can only be used on:
 - central systems with AKV valves
 - central systems with solenoid valves
 - brine systems with solenoid valves.
- Each of the individual evaporator sections is controlled individually using a modulating thermostat function.
- Cut-out value and difference **must** be set as with an ON/OFF thermostat.

One AKV valve for each evaporator + modulating thermostat
 Here, one valve is used per evaporator and the temperature is controlled individually in each evaporator section according to the modulating thermostat principle.

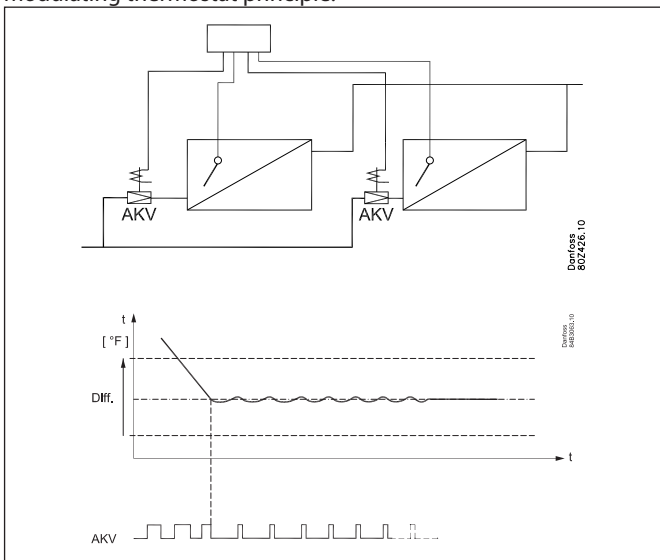

The thermostat in each section controls the temperature via the S3/S4 sensors in each section.

During cooling and in the case of major load variations in which the temperature falls outside of the thermostat limits, injection is regulated so that the evaporator operates with the minimum possible stable superheating. This ensures that the cooling process takes place as quickly as possible.

In the case of stable loads, the thermostat will reduce the opening time for the AKV valve, so the through flow of refrigerant is restricted to precisely the amount that is required to maintain the temperature at the required reference (area control).

The reference temperature will be the set cut-out temperature + half the difference.

The cut-out temperature and difference are set as in the case of a standard On/Off thermostat. The difference should **not** be set to less than 4°F. (In the case of a smaller difference, load changes could interfere with the modulating thermostat function.)

One solenoid valve for each evaporator + modulating thermostat
 Here, one valve is used per evaporator and the temperature is controlled individually in each evaporator section according to the modulating thermostat principle.

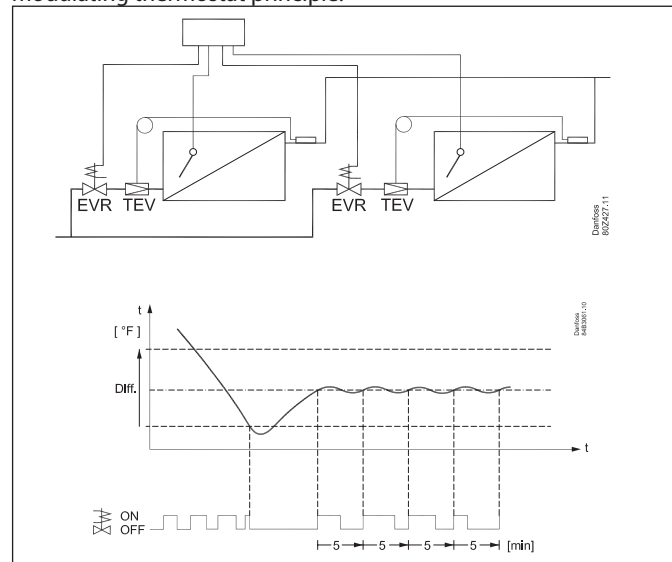

With solenoid valves, a pulse modulating principle is used with an adjustable period. The valve is opened and closed within a period (e.g. 5 minutes). A PI controller calculates how long the valve needs to be open in order to maintain the most constant temperature.

The reference temperature will be the set cut-out temperature + half the difference.

The cut-out temperature and difference are set as in the case of a standard On/Off thermostat. The difference should not be set to less than 4°F. (In the case of a smaller difference, load changes could interfere with the modulating thermostat function.)

The current load on the appliance can be read off in the form of the valve's opening time as a percentage of the set period.

Desynchronisation of valve openings

To achieve even loading on the compressors, a desynchronising function has been built in which ensures that the times for solenoid valve opening are displaced.

Within the same controller

If several valves are used on the same controller, the opening times are displaced in relation to one another. For example, if two valves are used, the opening of these is displaced in relation to one another by half a period.

Between controller

Displacement of the opening of the solenoid valves takes place on the basis of the controllers' address settings. If a period time of 300 seconds (factory default) is used, the opening of the solenoid valves for the A section will be displaced by 15 seconds x last digit in the address setting, e.g.:

Addresses 0, 10, 20: are shifted by 0 seconds

Addresses 1, 11, 21: are shifted by 15 seconds, etc.

This desynchronisation between controller takes place during start-up and once a day at around midnight, 00:00

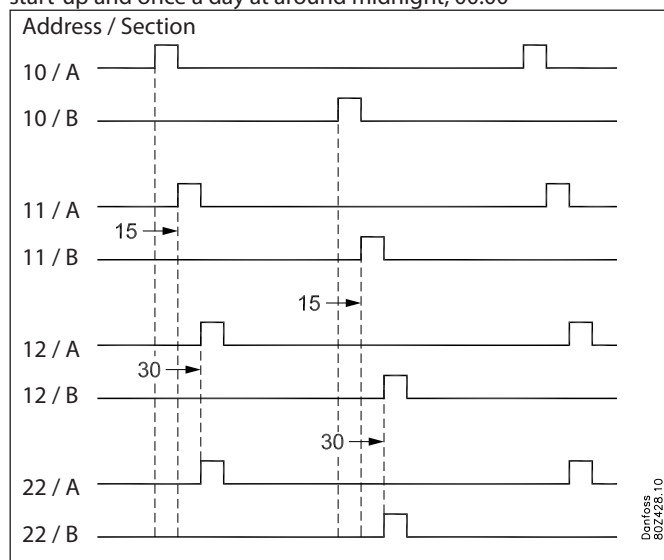

Thermostat sensor

Individual thermostat

When individual thermostat control is used in every section, the temperature is controlled on the basis of the air temperature sensors S3, S4 or both.

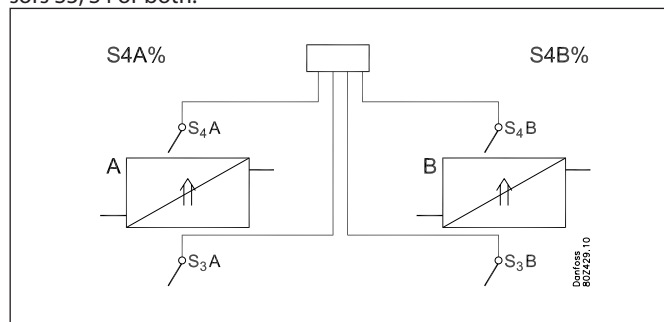

Definition of the thermostat temperature takes place using one setting, which is based on the S4 value. With a setting of 100%, only the S4 measurement will be used. With a setting of 0%, only S3 will be used. With a value between 0 and 100%, both measurements will be used.

If AKV valves are used, at least one sensor must always be used in every section, irrespective of the choice of thermostat function. This measurement is used by the injection function for the superheat controller.

Common thermostat

When a common thermostat is used, the thermostat settings in section A are used to control the air temperature.

The thermostat temperature can be either a weighting of the S3 and S4 sensors in section A, as described for the individual thermostat. This will typically be used in cold storage rooms and freezer rooms in which several evaporators are controlled according to a common temperature.

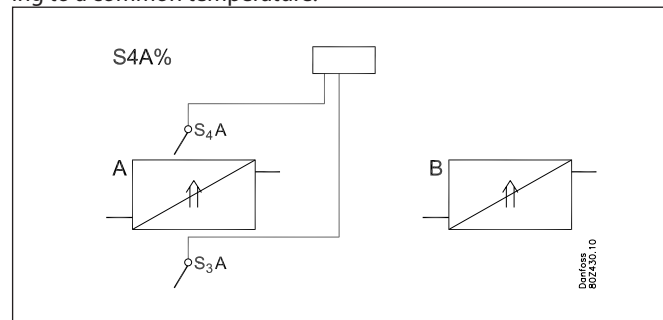

Alternatively, the thermostat temperature can be a minimum value, a maximum value or an average value of all S3 or S4 sensors for the refrigeration sections used. This will typically be used where one solenoid valve is used for several appliance sections and where it is necessary to ensure that the thermostat is taking into account the temperature in all sections.

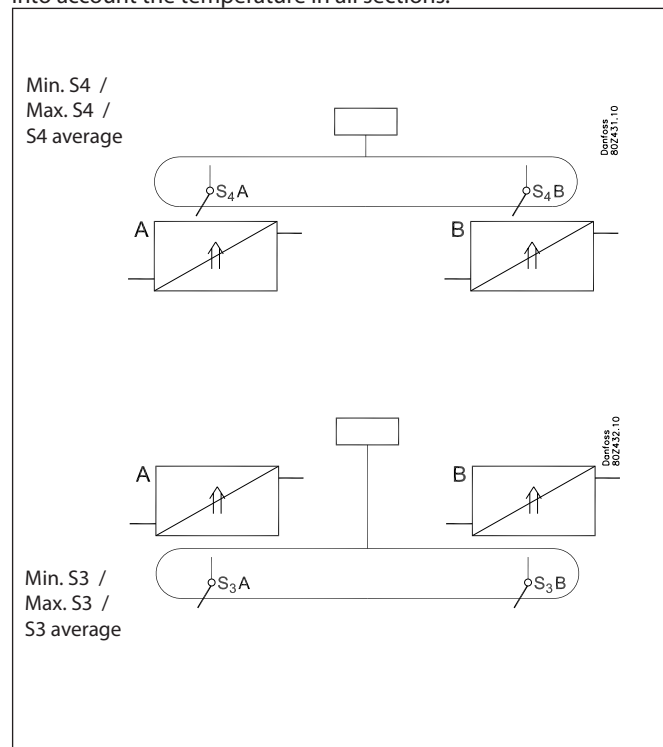

Switch between two thermostat band (two references)

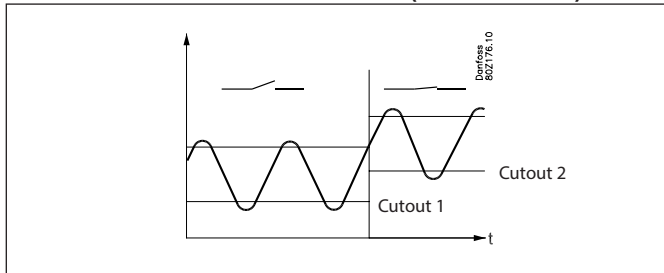

It is a good idea to use this function for refrigeration appliances containing impulse purchases where the products are often exchanged. Via a switch function it is possible to change between two thermostat settings depending on the products contained in the appliance. The change-over between two thermostat bands is activated via a contact or via a pulse signal of at least three seconds' duration – as a rule via a key switch placed on the appliance. When the switch is activated the thermostat settings as well as the limits for the alarm thermostat and the product sensor will change.

The changeover between the two thermostat bands can also be seen on the display, but only if the shift is set to take place with a pulse signal.

When a change-over is activated the display will show to which thermostat band the change goes.

Displacement of reference for thermostat

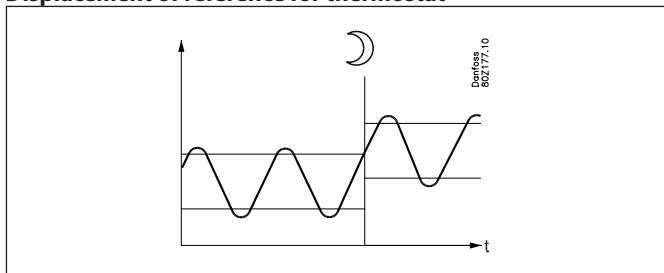

In refrigeration appliances there may be big load differences between the shop's opening and closing hours, especially if Night blinds/curtains are used. The thermostat reference may be raised here without it having any effect on the product temperature. Change-over between day and night operation can take place, as follows:

- via the built-in weekly schedule
- via an external switch signal
- via a signal from the data communication

When night operation starts the thermostat reference will be displaced with an offset value that normally will be positive. It must however be negative if cold accumulation is to take place.

When a Night blind is used the distribution of air in the appliance will change radically. A change of the thermostat's weighted S3/S4 ratio will therefore be required. As a rule the S4 share is set at a lower value during the night than during the day.

The thermostat reference can be displaced via an external voltage signal which is particularly useful for process cooling.

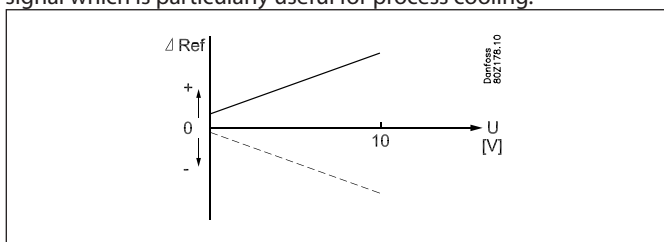

The signal may be a 0-5V, 0-10V, 1-5V or 2-10V voltage signal. Two offset values must be set, one indicating the displacement at minimum signal and another indicating the displacement at maximum signal. The displacement will apply to all sections. The displacement will not affect the alarm limits.

Melting function

This function will stop the air flow in the evaporator from being reduced by frost created by uninterrupted operation for a long time. The function is activated if the thermostat temperature has remained in the range between 23°F and 50°F for a longer period than the set melting interval. The refrigeration will then be stopped during the set melting period. The frost will be melted so that the air flow and hence the evaporator's capacity will be greatly improved.

The settings for melting interval and melting period are common to all sections, but the controller will displace the melting time for the different sections so that no synchronisation will take place. If there are several controllers in the same defrost group the time between the two meltings should be set differently in the individual controllers. In this way a synchronisation of the thermostats' cutin times will be avoided.

Timer for compressor relay

If a compressor relay has been selected, the relay's timer function will have higher priority than the thermostat function.

Temperature alarms

Alarm thermostat

The function is used for sounding the alarm before the product temperature at the refrigeration site becomes critical. You can set alarm limits and time delays for high and low temperatures. Alarm will be given if the set limit is exceeded, but not until the time delay has expired. There will be no alarms when refrigeration has been stopped due to cleaning of the appliance or if the main switch is set in pos. OFF. The alarm sensor may be chosen independently of the sensor used for the thermostat function.

Alarm sensor

The alarm sensor may be selected as either S3 or S4, or a weighted value of both of them. The setting is performed as a percentage value of S4. The weighting need not be the same as for the thermostat function. In other words, the thermostat may regulate according to S4 and the alarm thermostat may give alarm according to S3.

Alarm limits

Different alarm limits can be set for the individual sections. The alarm limits are set as absolute values in °F. If thermostat bands are used, separate limits can be set for each thermostat band. The alarm limits are not affected during night operation or if there is an external reference displacement via a voltage signal.

Time delay

Three time delays are set for alarms:

- For too low temperature
- For too high temperature during normal regulation
- For too high temperature during cooling down
 - after activation of internal or external start/stop
 - during a defrost
 - after a power failure
 - after appliance cleaning.

The time delay will apply until the actual air temperature has dropped below the "upper alarm limit".

- Curve 1: Cooling stage
 - (1): Time delay has been exceeded. Alarm becomes active.
- Curve 2: Normal regulation where the temperature becomes too high
 - (2): Time delay has been exceeded. Alarm becomes active.
- Curve 3: Temperature becomes too low
 - (3): Time delay has been exceeded. Alarm becomes active.

If regulation is carried out with two thermostat bands there will be a set of alarm limits for each band. Time delays will be common to the two bands.

Frost alarm

If the thermostat is controlled according to the S3 temperature or a weighting of S3/S4, there could be a risk (on the refrigeration shelves) that the evaporator's S4 discharge temperature may become so cold that the products at the back of the shelves become exposed to unintended frost temperatures. To prevent this, the controller has a built-in frost alarm. If the S4 temperature falls below a set frost limit an alarm will be given so that the cause of the cold outlet temperature can be found and corrected.

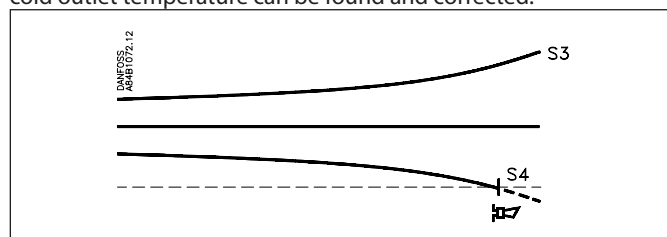

Example

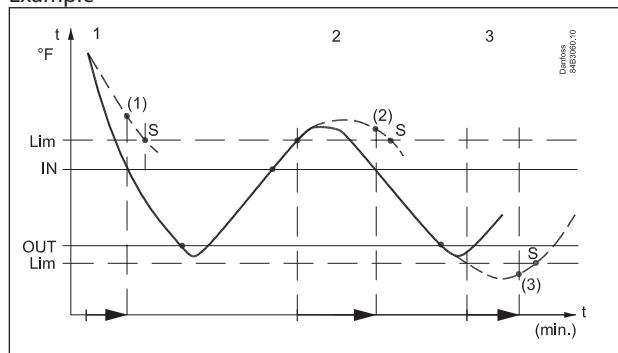

IN: Thermostat cut-in value
 OUT: Thermostat cut-out value
 Lim: Alarm limit for high temperature and low temperature
 S: Alarm ceases

Common functions

Fan control

To obtain energy savings it is possible to pulse control the power supply to the fans at the evaporators.

Pulse control can be accomplished in one of the following ways:

- during the thermostat's cutout period (cold room)
- during night operation and during the thermostat's cutout period (appliance with Night blind)

Pulse control only takes place when all sections/evaporators are cut out.

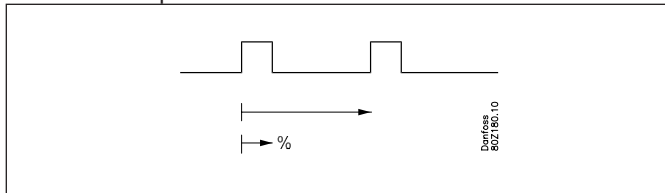

A period of time is set as well as the percentage of this period of time where the fans have to be operating.

Stop of fans if cooling is missing

If the refrigeration in a breakdown situation stops, the temperature in the cold room may rise quickly as a result of the power supply from large fans. In order to prevent this situation the controller can stop the fans if the temperature at S5 exceeds a set limit value. The function can also be used as a sort of MOP function during start-up with a hot evaporator. The fans will not start until the S5 temperature has been reached below the set limit value. In other words, the evaporator and hence the compressor will not be so heavily loaded during the startup phase.

The function uses the S5 sensor from section A.

The function is not active when refrigeration has stopped.

Anti sweat heat control

It is possible to pulse-control the power to the ASH in order to save energy. Pulse control can either be controlled according to day/night load or dew point.

Pulse control according to day and night

Various ON periods can be set for day and night operation.

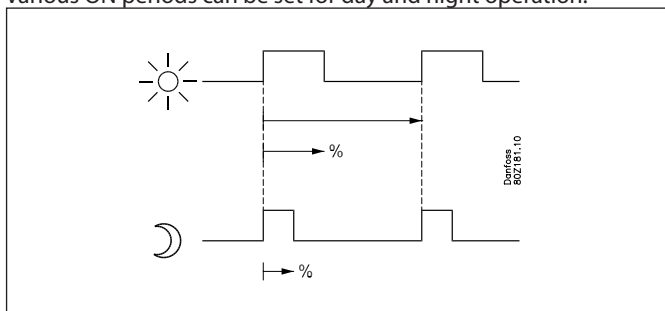

A period time is set as well as the percentage part of the period in which the ASH is ON.

Pulse control according to dew point

In order to use this function a system manager of the type AK-SC 255 is required which can measure dew point and distribute the current dew point to the appliance controllers. For this the ASH ON period is controlled from the current dew point.

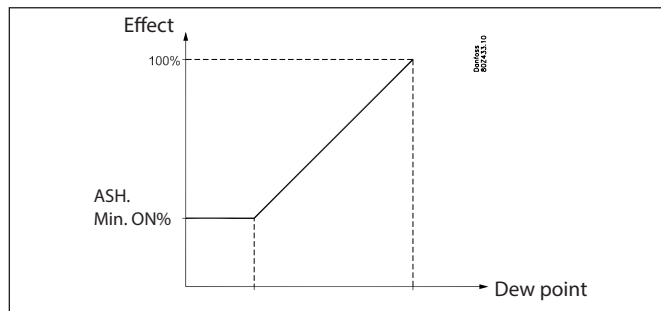

Two dew point values are set in the appliance control:

- One where the effect must be max. i.e. 100%.
- One where the effect must be min.

At a dew point which is equal to or lower than the value, the effect will be the value indicated in "ASH min ON%".

In the area between the two dew point values the controller will manage the power to be supplied to the rail heat.

The current dew point and duty cycle for ASH can be read off as status values.

If the dew point signal cannot be distributed to a controller, the ASH will revert to day/night control.

During defrost the ASH will always be 100% ON.

If ASH ON is selected, it will run at 100% during defrost + the time after defrost if the thermostat temperature is above the cut-in limit (but max. 15 minutes).

Compressor control

The controller has a function that can be used for compressor control. When the function is selected ON a relay will automatically follow the status of the thermostat functions. The relay is ON when the thermostat demands refrigeration. If the thermostat function is selected OFF the compressor output will constantly be ON.

A minimum ON time and a minimum restart time for the relay belong to the function.

The relay will be OFF during defrost.

There is display of:

- operating hours during the past 24 hours
- total number of operating hours
- number of couplings during the past 24 hours
- total number of couplings

Appliance cleaning

This function makes it easy for the shop's staff to carry out a cleaning of the appliance according to a standard procedure.

Function

Appliance cleaning is activated via a pulse signal of minimum three seconds' duration – as a rule via a key switch placed on the appliance. It can however also be activated via data communication. Appliance cleaning is carried out via three phases:

- 1 - at the first activation the refrigeration is stopped, but the fans keep on operating in order to defrost the evaporators. "Fan" is shown on the display.
- 2 - at the second activation the fans are also stopped and the appliance can now be cleaned. "OFF" is shown on the display.
- 3 - At the third activation refrigeration is recommenced. The display will show the actual appliance temperature.

To carry out cleaning of a frost appliance as quickly as possible cleaning can be started with a defrost sequence.

When appliance cleaning is activated a cleaning alarm is transmitted to the normal alarm recipient. A later processing of these alarms will document that the appliance has been cleaned as often as planned. The function saves information on when the last appliance cleaning was carried out and how long it lasted.

Appliance shutdown

This function makes it possible to shut down a refrigeration appliance using data communication or a switch signal.

When the signal is received, refrigeration stops. Fans and lights will do the following depending on the setup:

- Fans continue. The light will follow the standard setup.
- Fans stop immediately. The light immediately switches off.
- Fans stop when the delay time expires. The light will follow the standard light control.
- Fans stop when the delay time expires. The light switches off when the delay time expires.

The shutdown delay time is adjustable and applies to both fans and lights.

Any night curtain output will follow the light function.

Door contact

The door contact function can be defined for two different applications:

- Door alarm

The controller monitors the door contact and delivers an alarm message if the door has been opened for a longer period than the set alarm delay.

- Stop of refrigeration + door alarm

When the door is opened the refrigeration is stopped, i.e. the injection, and the fan are stopped. If the door remains open for a longer time than the set restart time, refrigeration will be resumed. This will ensure that refrigeration is maintained even if the door is left open or the door contact should be defective. If the door remains open for a longer period than the set alarm delay an alarm will also be sounded.

In both applications the alarm function will also contain a local reminder which is activated when 75% of the set time has been passed. This reminder only appears on the connected display and the intention of it is that the door must be closed before the alarm for open door is released.

From the controller the following can be read:

- the duration of the last open period
- the total open period during the past 24 hour
- number of openings during the past 24 hours

Defrost has higher priority than the door function. That is to say, refrigeration and fans will not be started until defrost is complete.

The door contact function can also activate the light function so that the light is turned on and kept on for a period of time after the door has again been closed. Cf. the section on light function.

Light function

The function can be used for controlling the light in a refrigeration appliance or in a cold room. It can also be used for controlling a motorised night curtain.

The light function can be defined in three ways:

- the light is controlled via a signal from a door contact. Together with this function a time delay can be set so that the light is kept burning for a period of time after the door has been closed.
- the light is controlled via the day/night function

- the light is controlled via the data communication from a system unit.

It is possible to set whether the light is to be switched on or off when the main controller switch is activated.

This is set in the function "Light at main switch=off".

If "Light at main switch=off" is set to ON, the normal light function will be maintained when the main switch is switched off.

If OFF is selected for this setting, the light will stay off when the main switch is switched off.

Night blind

Motorised night blind can be controlled automatically from the controller. The night blinds will follow the status of the light function. When the light is switched on, the night blinds opens and when the light is switched off, the night blinds close again. When the night blinds are closed, it is possible to open them using a switch signal on the digital input. If this input is activated, the night blinds will open and the refrigeration appliance can be filled with new products. If the input is activated again, the blinds close again.

When the night blind function is used, the thermostat function can control with different weighting between the S3 and S4 sensors. A weighting during day operation and another when the blind is closed.

A night blind is open when the appliance cleaning function is activated.

Forced closing

The AKV valves can be closed with an external signal (the "Inject ON signal"). The function must be used in connection with the compressor's safety circuit, so that there will be no injection of liquid into the evaporator when the compressor is stopped by the safety controls. (However not at low pressure – LP).

If a defrost cycle is in progress, the forced closing status will not be re-established until the defrost is completed.

The signal can also be received from the DI-input or be received via the data communication.

During a forced closing the fans can be defined to be stopped or in operation.

Alarm relay

If the controller is to give alarm at a relay output, the relay must be defined.

A setting determines when the relay is activated:

- Only for alarms with "high" priority
- For alarms with "low" and "medium" priority
- For alarms with "low", "medium" and "high" priority.

Start/stop of regulation (main switch)

A software setting is used for starting and stopping the regulating function.

ON = normal regulating function

OFF = Regulation stopped. All outputs will be set in standby mode. All alarms are stopped. An alarm can however be transmitted to the effect that regulation has stopped.

The function applies to all sections.

You can also define an external switch for start/stop of the regulation.

If an external switch is defined regulation will only be carried out when both switches are in position "ON".

Liquid injection

Principle

Up to four valves can be connected. One for each solid state output.

Control can be carried out with electrically operated expansion valves type AKV.

Or injection can take place with thermostatic expansion valves (TEV) where the temperature will then be regulated with solenoid valves type EVR or similar.

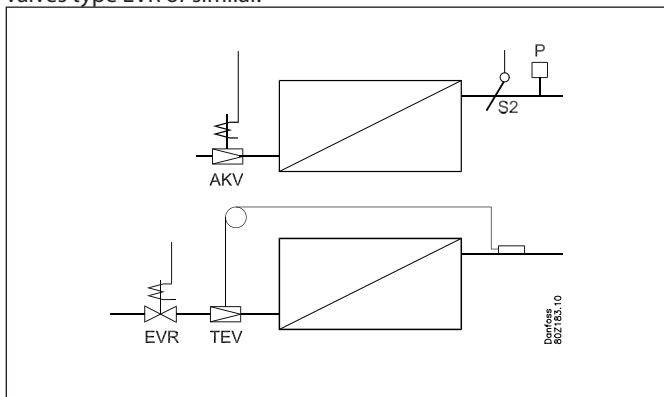

Adaptive superheat with AKV valve

The evaporating temperature is measured with pressure transmitter P and the superheat with the pressure transmitter and the S2 sensor.

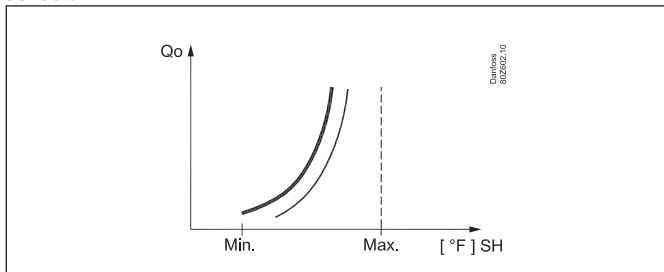

The function contains an adaptive algorithm that independently adjusts the valve's opening degree, so that the evaporator constantly delivers optimum refrigeration at lowest possible superheat.

The superheat reference will be limited by the settings for min. and max. superheat.

If the superheat is very low, the valve may be closed very quickly using the "SH closed" setting.

When the superheat has dropped to 2°F over the "SH closed" limit, this function will reduce the degree of opening of the valve so that the valve will with certainty remain closed if the superheat fall to the "SH closed" value. To ensure that the close function does not generate the general superheat regulation, the "SH closed" setting must be at least 2°F lower than "SH min".

One pressure transmitter can supply signals to several controllers if they regulate refrigeration points on the same suction line. But if a valve is mounted in an evaporator's suction line, say, a KVP / KVQ or PM, the pressure transmitter must be placed before the valve. The signal can now only be used by the relevant controller.

Refrigerant

Before regulation can be commenced, the refrigerant must be defined.

You can directly select one of the current refrigerants:

1 R12	11 R114	21 R407A	31 R422A
2 R22	12 R142b	22 R407B	32 R413A
3 R134a	13 Brugerdefineret	23 R410A	33 R422D
4 R502	14 R32	24 R170	34 R427A
5 R717	15 R227	25 R290	35 R438A
6 R13	16 R401A	26 R600	36 XP10
7 R13b1	17 R507	27 R600a	37 R407F
8 R23	18 R402A	28 R744	38 R1234ze*
9 R500	19 R404A	29 R1270	39 R1234yf*
10 R503	20 R407C	30 R417A	

*) Only 080Z0139

If a new refrigerant is demanded which is not as yet contained on the list you may select "User-defined" which is subsequently set with data for the refrigerant in question. The values can be ordered from Danfoss.

Warning: Incorrect selection of refrigerant can cause damage to the compressor.

MOP control

(MOP = Max. Operating Pressure)

The MOP function limits the valve's degree of opening as long as the evaporating temperature measured by Po is higher than the set MOP temperature. The function can only be active when the AKV injection valve function is ON.

Start/stop of injection

The injection can be stopped separately for each evaporator section.

Defrost

There is a common defrost start for all evaporator sections. Defrost stop can be common or individual when based on temperature. Refrigeration will not be re-started until defrost has been accomplished in all sections.

Fan control during defrost

Choose whether the fans should be running or stopped during the defrost sequence.

Coordinated defrost

If there are several controllers that are to perform defrost at the same time they can be grouped from the system unit. The system unit will start the defrosts, and when the defrost of the individual controllers is later finished they will go into "stand-by" position until all the defrosts have been terminated. Refrigeration is then resumed.

Drip tray heating element

It is possible to control a heating element in the drip tray for hot gas defrost. When defrost is commenced, the heating element is activated. The heating element remains activated until a set time after defrost has ended by time or temperature.

Defrost type

Electric defrost

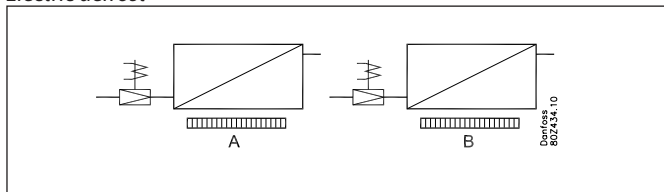

When there is electric defrost, the individual sections' heating elements are controlled separately.

Natural defrost

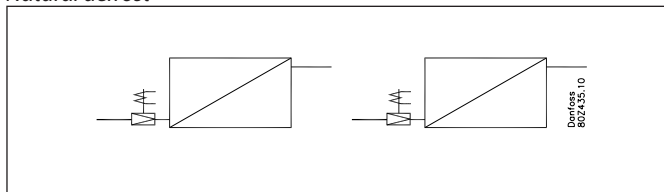

Defrost is accomplished here by the fans circulating air through the evaporator.

Warm brine defrost

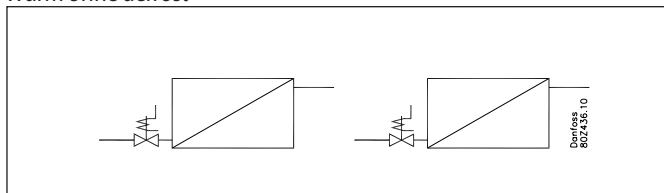

Warm brine defrost can be used on indirect refrigeration systems with solenoid valves. During warm brine defrost, the solenoid

valve is kept open during defrost so that the warm brine can run through the "evaporator".

Hot gas defrost

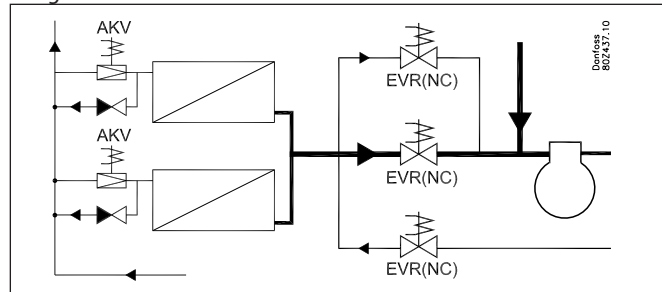

During hot gas defrost, the controller regulates valves in the liquid line, hot gas valves, a suction line valve and a drain valve.

Defrost start

Defrost can be started in several ways. Once started it will continue until a "defrost stop" signal is received.

- Manual defrost

Manual defrost can be enabled via a setting in the controller or via the bottom button on the display.

After activation the setting moves back to position OFF when the defrost has been completed.

- External signal on input

Defrost start is done with a signal on a DI input. The signal must be an impulse signal of at least three seconds' duration. Defrost starts when the signal moves from OFF to ON.

- Schedule - weekly programme

Defrost can be started via an internal schedule or via an external schedule placed in the network's system unit.

• Internal schedule

Defrost is started by means of a weekly programme that is set in the controller. The times have relation to the controller's clock function. Up to eight defrosts per 24 hours can be set. The schedule can be found via the "Overview display" / "Defrost" / "Schedule".

• External schedule

Defrost is started via a signal from the network's system unit

- Interval

Defrost starts with set intervals, e.g. every eight hours. An interval must ALWAYS be set to a "higher" value than the period set between two defrosts when a schedule or network signal is used. Defrost according to intervals ensures that defrost always takes place, even if no signal is received from the network's system unit.

- Adaptive defrost

This function can cancel planned defrosts which are not necessary, and on its own initiative it can start a defrost if the evaporator is about to be blocked by rime and ice.

(The "Adaptive defrost" function is described at the end of the section.)

Defrost sequence

Every defrost runs through the following sequence:

- emptying of evaporator (pump down) (state 1)
- defrost is initiated (state 3)
- waiting position (used for coordinated defrost) (state 4)
- drip-off (injection delay) (state 5)
- Pressure equalisation where the drain valve opens (hot gas defrost only) (state 6)
- fan delay (state 7)

Emptying of evaporator (state 1)

Before the defrost heating elements are started it is possible to carry out emptying of the evaporator. During a set time delay, the valve in the liquid line remains closed, the fans run and the evaporator is drained of refrigerant.

Defrost (state 3)

- Electric defrost
The electric heating elements are activated here.
- Natural defrost
Here, the fans run in order to defrost the evaporator using air circulation alone.
- Hot gas defrost
Here, the drain valve and suction line valve are closed. The hot gas valve opens in order to feed hot gas through the evaporator.
- Warm brine defrost
Here, the solenoid valve is held open so that warm brine can be fed through the evaporator.

Defrost stop

There are four kinds of defrost stop to choose from.

- Individual stop using temperature and with time as security
In the case of electric and hot gas defrost, one output per evaporator is used here, i.e. an individual heating element / hot gas valve per evaporator.

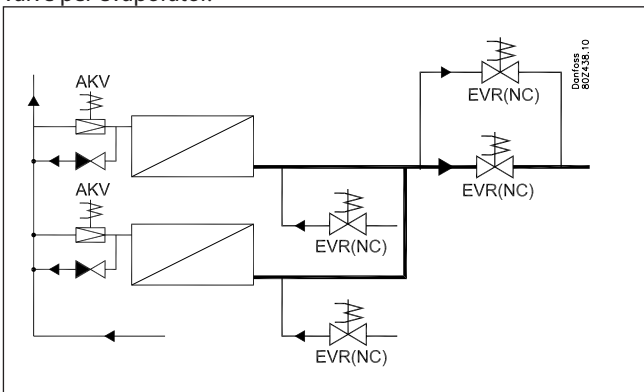

Example of hot gas usage with individual stop per evaporator

The temperatures of each evaporator are measured using a sensor. When this temperature is then equal to or greater than the set temperature for defrost stop, defrost stops in the section in question. The defrost sequence continues only when all sections have completed defrost.

When there is electric defrost, S5 is normally selected as defrost sensor, but S3, S4 or S2 may also be selected (S3 is an air sensor placed in the evaporator inlet, and S4 is an air sensor placed in the evaporator outlet).

For large evaporators there should be two S5 sensors – S5-1 and S5-2. The defrost is stopped when both temperatures have attained the set value.

If the defrost time exceeds the set max. defrost time, the defrost stops. This will happen even if the defrost stop temperature has not been reached (max. defrost time will function as safeguard). When the defrost is stopped on time, the alarm message "Max. def. period exceeded" will appear for the section in question. If the alarm is not acknowledged within five minutes, it will automatically be cancelled.

When there is an error in a defrost sensor, an alarm appears and the defrost stop will then be based on time in the relevant section. Defrost stop for the remaining sections will still be based on temperature.

- Common stop using temperature and with time as security
In the case of electric and hot gas defrost, only one output is used for all evaporators, i.e. one output for heating element / common hot gas valve.

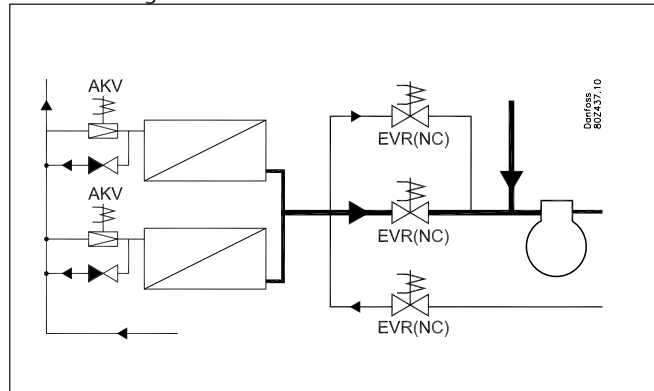

Example of hot gas usage with common hot gas valve for all evaporators

The temperatures of each evaporator are measured using a sensor. Once all the evaporator temperatures are equal to or greater than the set temperature for defrost stop, defrosting is stopped in all sections and the defrost sequence continues.

The selection of defrost stop sensor as well as the "safeguard" stop on time if stop temperature can not be reached is exactly as described for individual stop.

- Stop based on time
A fixed defrost time is set here. When this time has elapsed, the defrost will be stopped and cooling will be resumed. (When stop on time the controller does not check whether one or more of the evaporators still require defrost.)

- Stop based on DI signal
 - Stop via a common DI signal
 - Stop via an individual DI for each section.

- Manual stop
Defrost in progress can be stopped manually by enabling the "Stop defrosting" function."

If a signal on forced closing during a defrost is received, the forced closing status will not appear until the defrost has been finished.

Coordinated defrost (state 4)

Via a system unit it is possible to perform a group defrost with other appliance controllers. The system unit will in that case start a defrost with a start signal via the data communication. When the

first section of a controller has finished defrost, the controller starts the "Max. hold time" function and when all sections have finished defrost, this is recorded by the system unit. The controller will then move into waiting position until it receives a signal to restart refrigeration. This happens when all controllers in the group have concluded their defrosts. If this message has not been received within the "Max. holding time" time, the controller will resume refrigeration under all circumstances.

Drip-off delay (state 5)

A time delay can be put in so that any drops of water may drip off the evaporator before refrigeration is resumed. In this way it is ensured that the evaporator as far as possible is free from water when refrigeration is restarted.

Drain delay / pressure equalisation during hot gas defrost (state 6)

When the drip delay is completed, it is possible to add a drain delay in which the smaller drain valve opens up to the suction line so that pressure equalisation takes place. Once the drain delay has expired, the main valve in the suction line opens and cooling is resumed.

Delayed fan start (state 7)

Regardless of whether the fans are running or have stopped during the defrost sequence, the fans can be stopped during this delay.

Drops of water left on an evaporator after defrost should be bound to the evaporator (primarily used in freezing rooms).

After defrost, the liquid injection is started, the evaporator is cooled down, but the fans will be started a little later. During this period the controllers operate the expansion valve by force, but they constantly monitor the superheat.

The temperature at which the fans are to be started is set (measured always with the S5 sensors). The max. permissible time delay in minutes is set.

The time delay for fan start will not commence until the time delay for liquid injection, if applicable, has run out.

Only when all the S5 sensors register a lower temperature than the set will the fans be started. If all S5 sensors do not register a lower temperature than the set by the delay time has elapsed, the fans will start. At the same time alarm is given that Maximum delay time for fan is exceeded for the section in question. If the alarm is not acknowledged within five minutes, it will automatically be cancelled.

If some of the S5 sensors are defective, the signal from sensors that remain intact will be used.

Example

Below is an example of a defrost sequence using hot gas defrost.

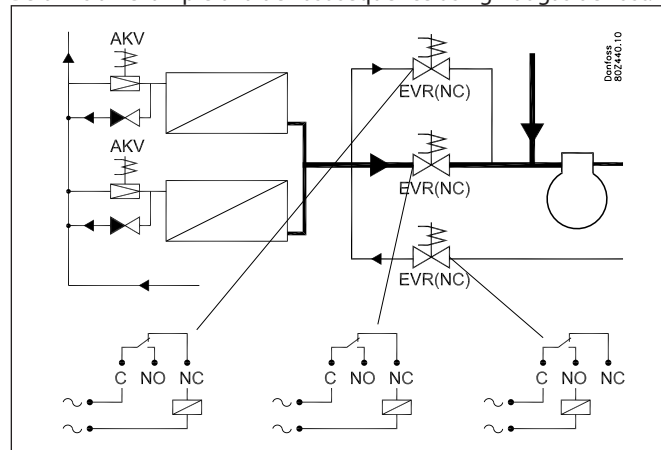

The following are used in the example:

- Hot gas defrost with common hot gas valves
- Defrost using the evaporators is stopped individually using the S5 temperature
- The fans are stopped during defrost

The defrost sequence will be as follows:

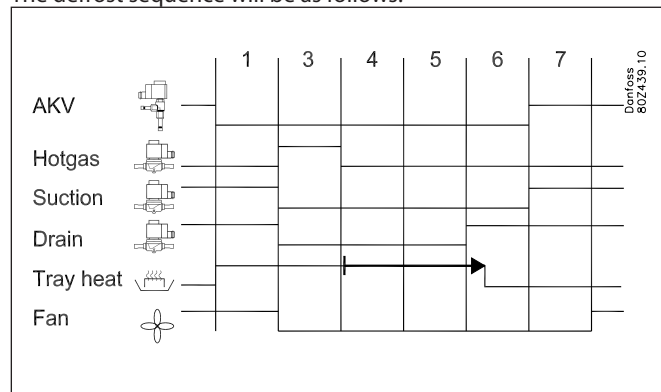

- Pump down (state 1)
The AKV valve closes, the heating element in the drip tray is activated and the fans run.
- Defrost (state 3)
The fans stop, the main valve and the drain valve in the suction line are closed and the hot gas valve opens. Defrost is terminated when the S5 sensor has reached its stop temperature.
- Hold (state 4)
If coordinated defrost is being used, the controller will wait for a release signal from the network's system unit before continuing with the sequence. Alternatively, the hold stops once the maximum hold time has expired.
- Drip delay (state 5)
Cooling is delayed so that any drops of water can run off the evaporator.
- Drain delay / pressure equalisation (state 6)
The drain valve opens so that pressure equalisation takes place in the evaporator.
- Fan delay (state 7)
The main valve in the suction line opens and liquid injection is resumed. The fans are delayed so that the remaining drops of water are bound to the evaporator. The fans start when the required fan start temperature has been reached on the S5 sensor, or when the set delay time has expired.

- Drip tray heating element
The drip tray heating element is switched off when the set delay time has expired. This delay time is applicable from the end of defrost (state 3).

Adaptive defrost

This function can cancel planned defrosts which are not necessary, and on its own initiative it can start a defrost if the evaporator is about to be blocked by rime and ice. This function is based on a registration of the air flow through the evaporator. By using the AKV valve as mass flowmeter for the refrigerant flow it is possible to compare the energy admission on the refrigerant side with the energy emission on the air side. Via this comparison the air flow through the evaporator can be determined and hence also the amount of ice/frost build-up on the evaporator surface.

Automatic adaptation to the evaporator

When adaptive defrost is activated it will carry out an automatic tuning in order to adapt itself to the relevant evaporator. The first tuning takes place after the first defrost so that tuning can be carried out on an evaporator without ice/rime formation. New tuning subsequently takes place after each defrost (but not at night with night blinds). In a few cases it may happen that the function is not correctly adapted to the relevant evaporator. This is usually because the automatic adjustment has been made under abnormal operating conditions at start-up/on testing the system. This will result in the function reporting an error state. If this happens, a manual reset of the function should take place while briefly setting the function switch to "OFF".

Status display

For each evaporator it is possible to display the current operating status for adaptive defrost:

- 0: OFF Function not activated
- 1: Error Reset to be carried out
- 2: Tuning Function carries out automatic tuning
- 3: OK - no ice build-up
- 4: Slight ice build-up
- 5: Medium ice build-up
- 6: Heavy ice build-up

Restrictions and sensor signals:

The following connections/signals must be used:

- Expansion valve type AKV
- Temperature signal from both S3 and S4
It is essential that the S3 and S4 sensors are located in the air flows of the evaporator inlet and evaporator outlet. The sensors must be mounted in such a way that the effects of external heat sources, such as fan motors, are minimised as far as possible.
- Pressure signal from condensation pressure Pc
The Pc signal can be received from a pressure transmitter which is connected to the controller, or it may be received via data communications from the system unit.
(Several controllers may share the same Pc signal.)
If the controller does not receive a Pc signal, it will use a constant value for the condensation pressure.
- Adaptive defrosting cannot be used if one of the following refrigerants are used for regulation: R23, XP10, R13B1 or user-defined.

This function can only cancel planned defrosts which start from a defrost schedule – either an internal schedule or an external schedule in the system unit. Other defrost start signals will always result in defrost.

This function will only cancel defrost if all evaporator sections so permit.

Function selection

This function can be set to operate in one of the following ways:

0. OFF:

The function is stopped. Any alarms are removed and the function is reset.

1. Monitoring only::

The function is used exclusively to monitor the formation of ice on the evaporator – the function will not cancel planned defrosts.

If the function detects severe ice/rime formation on an evaporator, an alarm "Appliance A – air flow reduced" is transmitted. The alarm is removed at the start of the next defrost.

2. Skipping of defrosts by day (appliances with night blinds)

This setting is used if function is only to cancel unnecessary defrosts by day, and if night blind is used for the appliance.

This function undertakes new tuning only when defrost takes place during day operation.

The controller MUST be set to night state when night time cover is set for the appliance – this may take place via a schedule in the controller or alternatively via a signal from the system unit.

This is because there is a risk of the function detecting the formation of rime/ice on the evaporator when night blind is set for the appliance. (A greater reduction in air flow may occur as a consequence of a small distance between night blinds and products.

It is important for night time cover to be removed from the appliance when the controller switches to day operation. If not, there is a risk of incorrect tuning, and hence missing data for cancelling defrosts. Correct tuning will take place only after the next defrost.

3. Skip defrost day and night (refrigeration rooms and appliances without night blind)

This setting is used if the function is to cancel defrosts for rooms and appliances without night blind.

New tuning of the function takes place after each defrost.

4. Full adaptive defrost

This setting is used if the function is to start defrosts on its own initiative. The setting can ideally be used in refrigeration/frost rooms where the time of defrost is not as important. In refrigeration/frost rooms, this setting can ensure major savings as defrosts take place only when necessary. Scheduled defrosts will always be carried out. That is to say, a basic schedule can be input and the adaptive function will then start extra defrosts itself where necessary..

Minimum time between defrosts

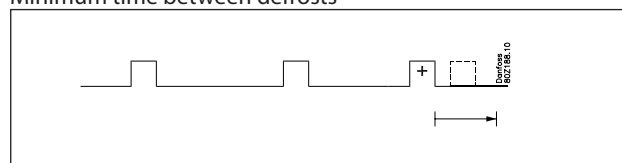

It is possible to enter a minimum time between defrosts. In this way it can be avoided that planned defrosts according to the weekly schedule be carried out immediately after the termination of a adaptive defrost. The time span is from the termination of a adaptive defrost and until a planned defrost is again allowed.

Documentation on saving

It is possible to read the number of planned defrosts and the number of cancelled defrosts.

Alarms

- Appliance not defrosted

If this function detects ice formation shortly after defrost, the "Appliance not defrosted" alarm is generated. This error may be due to the evaporator not being defrosted correctly as a consequence of faults in heating elements or fans. After this alarm, the function will not cancel defrosts.

This alarm is removed at the start of the next defrost, at which point cancellation of defrosts will be permitted again.

- Air flow reduced

If this function detects severe ice formation on the evaporator, the alarm "Appliance X – air flow reduced" is transmitted. This error will typically be due to severe ice formation on the evaporator, but it may also be due to reduced air flow as a consequence of severe over stacking of goods or dropout of fans. After this alarm, the function will not cancel defrosts.

This alarm is removed at the start of the next defrost, at which point cancellation of defrosts will be permitted again.

- Sensor error

The controller cannot carry out a tuning calculation for use in the adaptive defrosting.

After this alarm, the function will not cancel defrosts.

This alarm is removed at the start of the next defrost, at which point cancellation of defrosts will be permitted again.

- Flash gas alarm

This function will monitor whether there is any flash gas at the expansion valve. If flash gas is detected over a fairly long period, the alarm "Appliance X – Flash gas alarm" is triggered.

This alarm is removed when flash gas disappears or at the start of the next defrost.

Miscellaneous

Alarm priorities

The different alarms that can be generated by the controller can be given a priority.

"priority" will activate the alarm relay if it has been so defined. The alarms are entered in the alarm log and also transmitted to the data communication if connected.

The "Log only" priority will as mentioned only be entered in the alarm log.

Setting	Log	Selection Alarm relay				Net work	AKM-dest.
		Non	High	Low-Middle	Low - High		
High	X		X		X	X	1
Medium	X			X	X	X	2
Low	X			X	X	X	3
Log Only	X						4
Disabled							

Sensor correction

The input signal from all connected sensors can be corrected. A correction will only be necessary if the sensor cable is long and has a small cross-sectional area. All displays and functions will reflect the corrected value.

Clock function

The controller contains a clock function, that can be used together with schedules for defrost and day/night operation.

In case of power failure the clock must be reset.

If the controller is linked up to a System Manager via the data communication, the System Manager will reset the clock.

Signals via data communication

The controller contains a number of functions that can be activated/overridden by the network's system unit:

Night operation

The day/night operation of the individual controllers can be controlled from a central weekly schedule in the system unit.

Interruption of injection

The system unit can ensure that all appliance and room controllers force-close their AKV valves if all compressors in the belonging central plant stop due to operation breakdowns and are prevented from starting again.

Light control

In appliance controllers the light can be controlled via a central weekly schedule in the system unit.

Coordinated defrost

Several appliance controllers can be grouped in the system unit so that they will start a defrost at the same time and subsequently start up after defrost at the same time.

Adaptive defrosting

By using the "Adaptive Defrosting" function the controller must receive a condensing pressure signal Pc. This signal must be received from the System Manager.

Optimization of suction pressure

The appliance/room controllers can supply the necessary information to the system unit so that it can optimise the suction pressure based on the appliance with the heaviest load.

Forced refrigeration

The controller will undertake refrigeration when this signal is received. Refrigeration will continue until the signal is removed.

Sensor correction

The input signal from all connected sensors can be corrected.

Anti sweat heaters

The anti sweat heater control can be overridden.

Display signal

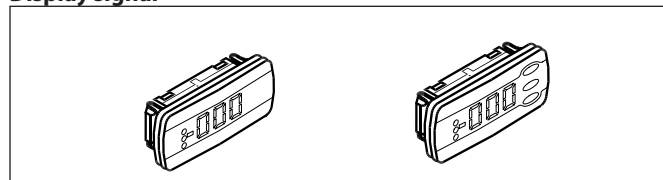

The air temperatures measured at the evaporator can be read from a display. This display must be of display type EKA 163B or EKA 164B. The display is normally mounted on the appliance so that the customer can see the air temperature. Up to four displays per controller can be fitted.

Connection is effected by means of wires with plug connectors.

The display can be placed on an appliance front, for example.

When a display with operating buttons is selected, the unit can be operated with ease by means of a menu system as well as displaying temperatures and operating situations.

Display signal

Temperature display can be selected for a product sensor, or alternatively a weighted condition between air sensors S3 and S4. Setting is expressed as a percentage of the S4 signal.

The display is independent of the thermostat function.

An Offset can be set for the display.

Values are displayed by means of three digits, and one setting allows you to decide whether the temperature is to be displayed in °C or °F.

LEDs on the front

The LEDs will come on when the associated relay is activated:

2nd LED = refrigeration

3rd LED = defrost

4th LED = ventilator operational

The LEDs will flash when an alarm has been triggered.

In this situation, you can call up the error code on the display by briefly pressing the top button.

The buttons

When you want to change a setting, the top and bottom buttons will give a higher or a lower value depending on which button you press. Before you can change the value, you must access the menu. This is done by holding down the top button for a couple of seconds; this takes you into the list of parameter codes. Find the parameter code you want to change, then press the centre button to display the parameter value. When you have changed this value, save the new value by pressing the centre button again

Examples:

Setting a menu

1. Press the top button to display a parameter
2. Press the top or bottom button and find the parameter you want to set
3. Press the centre button to display the value
4. Press the top or bottom button and set the new value
5. Press the centre button again to save the value.

Setting the temperature

1. Press the centre button to display the temperature setting
2. Press the top or bottom button and set the new value
3. Press the centre button to save the setting.

Read the temperature at the defrost sensor)

- Briefly press the bottom button

Manual start or stop of defrost

- Press the bottom button for 4 seconds.

Read codes

Normally the selected temperature signal can be read from the display, but under certain conditions the display may show other codes in order to notify the user of various operating states.

Function	Display read
Main switch	When the "main switch" is set to OFF, the display will read "OFF"
Defrost	During defrost, the display will read "-d-". The display will switch to normal temperature display when the thermostat temperature is in place, or the delay period "High temp alarm delay" has expired .
Case cleaning	When appliance cleaning is activated, the display will read "Fan" to indicate that the fans are running in order to defrost the evaporator. When the second stage of appliance cleaning is activated, the display reads "OFF" in order to indicate that the appliance can now be cleaned as all outputs are in standby position.
PAS	Requirement for access code. If operation of the display is to be protected by an access code, both the definition and the access code must be set in the controllers' authorisation menu for the local display (LOCD).
Alarm	The three LED's will flash if an alarm is triggered. The alarm code can be viewed by pressing the top button.
---	When three dashes appear, the valid temperature reading is faulty (sensor switched off or short-circuited), or else the display has been deactivated.
th1/th2	When the thermostat bank is changed by pressing a button, the display will display for 10 seconds which thermostat band is active.
-- 1 -- 2	Initiation, Display is connected to output A Output B. etc.

Get off to a good start when use of display

The following procedure will start regulation as quickly as possible:

1. Open parameter r12 and stop regulation (in a new appliance not set previously, r12 will already be set to 0, which means regulation stopped)
2. Open parameter o93 and set the configuration lock to a value of 0 (=OFF)
3. Open parameter 062 = Select a predefined use on the basis of the electrical connections which appear at the end of the manual. After configuration of this function, the controller will shut down and restart.
4. Once the controller has restarted, open parameter 093 and the configuration lock is opened = value 0.
5. If AKV valves are used, you must also select refrigerant via parameter o30.
6. Open parameter r12 and start regulation.
7. When there is a network: set the address for the address switch in the controller.
8. Send this address to the system unit by activating a service pin.

Menu overview:

A display can be connected for each evaporator section. In each display, the following settings/readings can be undertaken for the evaporator section in question.

Parameter name	Function	At start-up
r12	Main switch: 0: Controller stopped 1: Regulation	x
r22	Select thermostat band: 1 = Thermostat band 1 is active 2 = Thermostat band 2 is active	
r37	Setting of cut-out value for the thermostat in section A/B/C/D	
r38	Setting of cut-out value for thermostat band 2	
o30	Setting of refrigerant (must be set if AKV valves are used) 0= not selected, 1=R12. 2=R22. 3=R134a. 4=R502. 5=R717. 6=R13. 7=R13b1. 8=R23. 9=R500. 10=R503. 11=R114. 12=R142b. 13=User def. 14=R32. 15=R227. 16=R401A. 17=R507. 18=R402A. 19=R404A. 20=R407C. 21=R407A. 22=R407B. 23=R410A. 24=R170. 25=R290. 26=R600. 27=R600a. 28=R744. 29=R1270. 30=R417A. 31=R422A. 32=R413A. 33=R422D. 34=R427A. 35=R438A. 36=XP10. 37=R407F. 38*=R1234ze. 39*=R1234yf. *) Only 080Z0139	x
o46	Case cleaning function. Set: 0: Case cleaning not started 1: Only fan running (evaporator defrost) 2: All outputs are OFF (cleaning may be carried out)	
o62	Selection of predefined configuration. This setting will give a choice from a series of predefined combinations, which at the same time establish the connection points. At the end of the manual there is an overview of the options and connection points. After configuration of this function, the controller will shut down and restart.	x
o93	Configuration lock You can only select a preset configuration or change refrigerant when the configuration lock is open. 0 = Configuration open 1 = Configuration locked	x
u17	Actual air temperature for the thermostat in section A/B/C/D	
u20	Actual temperature at S2 sensor. Section A/B/C/D	
u21	Actual superheat. Section A/B/C/D	
u24	AKV valve opening degree. Section A/B/C/D	
u26	Actual evaporating temperature. Section A/B/C/D	
u36	Actual air temperature for product sensor in section A/B/C/D	
u68	Actual air temperature for alarm thermostat in section A/B/C/D	

X = When the controller is not set up, the display will only read the marked settings

Information

The controller offers quite a number of status displays which are invaluable in connection with operational start-up and optimisation.

Thermostat function

Display of S3 air admission
Display of S4 air emission
Display of weighted S3/S4 thermostat temperature
Min., Max. and Average thermostat temperature / 24 hours
Average thermostat coupling in % / 24 hours
Running time for cutin period in progress or for the last cutin period

Alarm thermostat

Display of weighted S3/S4 alarm temperature
Min., Max. and Average alarm temperature / 24 hours
Percentage of time where the alarm temperature was outside the limits / 24 hours

Product sensor

Display of the temperature at the product sensor
Min., Max and Average of product temperature / 24 hours
Percentage of time where the product temperature was outside the limits / 24 hours

Injection function

AKV opening degree in %
Average opening degree / 24 hours
Evaporating pressure
S2 gas temperature
Superheat
Superheat reference

Defrost

Actual defrost status
Degree of icing-up of evaporator
Duration of on-going or last defrost
Average duration of the last ten defrosts
Duration of cooling-down after defrost
Defrost sensor temperature
Number of planned and skipped defrosts

Compressor

Operating time last 24 hours
Total operating time
Number of couplings last 24 hours
Total number of couplings

Door contact

Door contact status
Duration of last opening
Number of openings last 24 hours
Opening time last 24 hours

Rail heat

Dew point
Actual duty cycle

Appliance cleaning

Time of last cleaning
Duration of last cleaning

Input and output status

Status display of all inputs and outputs
Manual overriding of all outputs

Regulating status

The controller goes through some regulating situations. You can see the actual situation here.

When operating with AK-ST the text is written on the screen for the section. When operating from AKM the operating status is a numerical value.

The values are, as follows:

- 0: Refrigeration stopped from Main Switch
- 1: Start-up phase for the injection function
- 2: Adaptive regulation of the superheat
- 3: -
- 4: Defrost
- 5: Start-up after defrost
- 6: Forced closing
- 7: Injection function failure
- 8: Sensor error and emergency refrigeration
- 9: Modulating thermostat control
- 10: Melting function is active
- 11: Open door
- 12: Case cleaning
- 13: Thermostat cutout
- 14: Forced refrigeration
- 15: Shut down

Defrost state

During and immediately after a defrost the defrost status will be:

- 1: Evaporator is emptied
- 3: Defrost
- 5: Evaporating pressure is lowered
- 6: The liquid injection is delayed
- 7: Fan delay

Installation considerations

Accidental damage, poor installation, or site conditions, can give rise to malfunctions of the control system, and ultimately lead to a plant breakdown.

Every possible safeguard is incorporated into our products to prevent this. However, a wrong installation, for example, could still present problems. Electronic controls are no substitute for normal, good engineering practice.

Danfoss will not be responsible for any goods, or plant components, damaged as a result of the above defects. It is the installer's responsibility to check the installation thoroughly, and to fit the necessary safety devices.

Particular attention is drawn to the need for a "force closing" signal to controllers in the event of compressor stoppage, and to the requirement for suction line accumulators.

The controller is not built for use on plate heat exchangers.

NH3 + AKVA

Please contact Danfoss if you require help concerning the positioning of sensors, transmitters, etc.

Your local Danfoss agent will be pleased to assist with further advice, etc.

Alarm texts

Setting of priority	Default priority	Alarm text	Description
---------------------	------------------	------------	-------------

Temperature alarms

High air temp. A	High	High air temp. (A,B,C,D)	The air temperature has been above the high alarm limit for longer time than set delay
Low air temp. A	High	Low air temp. (A,B,C,D)	The air temperature has been below the low alarm limit for longer time than set delay
Frost protect A	High	Frost protection, too low S4 (A,B,C,D)	The air off temperature (S4) is below the set frost protection limit
High Prod. temp. A	High	High Prod. temp. (A,B,C,D)	The product temperature has been above the high alarm limit for longer time than set delay
Low prod. temp. A	High	Low prod. temp. (A,B,C,D)	The product temperature has been below the low alarm limit for longer time than set delay
Same for B,C,D			

Sensor errors

Pe sensor error	Low	Po sensor error	Pressure transmitter signal for evaporating pressure faulty
S2A sensor error	High	S2A sensor error (B,C,D)	S2A temp. sensor signal faulty
S3A sensor error	High	S3A sensor error (B,C,D)	S3A temp. sensor signal faulty
S4A sensor error	High	S4A sensor error (B,C,D)	S4A temp. sensor signal faulty
S5-1A sensor error	High	S5-1A sensor error (B,C,D)	S5-1A temp. sensor signal faulty
S5-2A sensor error	High	S5-2A sensor error (B,C,D)	S5-2A temp. sensor signal faulty
Prod. sensor error A	High	Product temp. A sensor error (B,C,D)	Product temp. sensor signal faulty
Same for B,C,D			
Pc sensor error	High	Pc sensor error	Pressure transmitter signal for condensing pressure faulty

Various alarms

Standby mode	Medium	Control stopped, MainSwitch=OFF	The control has been stopped via the setting "Main switch" = ON or via the external Main switch input
Refrigerant changed	Low	Refrigerant changed	The refrigerant setting has been changed
Case cleaning	High	Case cleaning initiated	A case cleaning has been initiated
Door open pre alarm	Low	Door open pre alarm	The door has been open for longer time than 75% of the set alarm delay
Door open alarm	Medium	Door open alarm	The door has been open for longer time than set alarm delay
Injection problem A, B, C, D	Medium	Injection problem (A,B,C,D)	The AKV valve can not control the superheat of the evaporator
Max def period A,B,C,D	Low	Max defrost time exceeded (A,B,C,D)	The last defrost cycle has terminated on time instead of temperature
Max fan del exceeded A,B,C,D	Low	Max fan del ay time exceeded (A,B,C,D)	The fans have been started on time instead of temperature after a defrost
Max hold time A,B,C,D	Low	Max defrost hold time (A,B,C,D)	After a defrost cycle the evaporator has restarted cooling as it did not get a release signal via the defrost co-ordination setup in the network manager (AKA gateway)
Air flow alarm A,B,C,D	Low	AD - Case X - Air flow reduced	The air flow at the evaporator is greatly reduced – either as a consequence of severe ice formation, a fan fault or other obstruction.
AD – Case A not defrosted (B,C,D)	Low	AD - Case X not defrosted	The air flow is continuously reduced after defrost has been carried out
AD – Fault case A,B,C,D	Low	AD - Sensor error A,B,C,D	Tuning problem in adaptive defrost
AD – Flash gas evaporator A,B,C,D	Low	AD – Flash gas detect A,B,C,D	Flash gas has been detected at the valve for a relatively long time

System alarms

The alarm priority can not be altered on system alarms			
	Medium	Clock has not been set	Time has not been set
	Medium	System Critical exception	A unrecoverable critical system failure has occurred – exchange the controller
	Medium	System alarm exception	A minor system failure has occurred – power off controller
	Medium	Alarm destination disabled	When this alarm is activated the alarm transmission to the alarm receiver has been deactivated. When the alarm is cleared the alarm transmission to the alarm receiver has been activated.
	Medium	Alarm route failure	Alarms can not be transmitted to alarm receiver – check communication
	High	Alarm router full	The internal alarm buffer has an overrun – this might occur if the controller can not send the alarms to the alarm receiver. Check communication between controller and AKA gateway.
	Medium	Device is restarting	The controller is restarting after flash updating of the software
	Medium	IO module error	There is a communication fault between the controller module and the extension modules – the fault must be corrected as soon as possible
	Low	MAN DI.....	The output in question has been put in manual control mode via the AK-ST 500 service tool software
	Low	MAN DO.....	The output in question has been put in manual control mode via the AK-ST 500 service tool software

Appendix - Recommended connection

Function

The controller has a setting where you can choose between various types of installation. If you use these settings, the controller will suggest a series of connection points for the different functions. These points are shown below.

Even if your installation is not 100% as described below, you can still use the function. After use, you need only adjust the divergent settings. The given connection points in the controller can be changed if you wish.

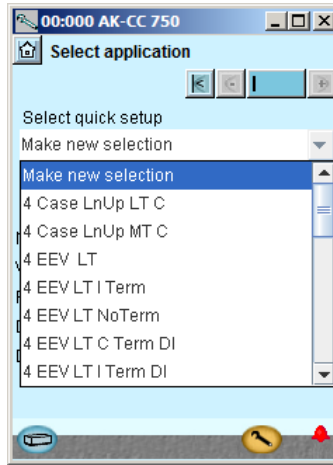

Descriptions:

- 'EEV' = electronic expansion valve
- 'LLSV' = liquid line solenoid valve
- 'LT' = low temp
- 'MT' = medium temp
- 'LnUp' = Line Up
- 'I Term' = individual termination (sensor)
- 'C Term' = common termination (sensor)
- 'I Term DI' = individual termination, digital input
- 'C Term DI' = common termination, digital input
- 'CPM' = case power module
- 'Comm Term' = common termination (sensor)
- 'Ind Term' = individual termination (sensor)
- 'AD C Term' = adaptive defrost, common termination (sensor)
- 'AD I Term' = adaptive defrost, individual termination (sensor)
- 'DT C Term' = dual temp, common termination (sensor)
- 'DT I Term' = dual temp, individual termination (sensor)

	Comments		Quick Setup IO Assignments							
1		4 Case LnUp LT C	AI Points (Base Module)							
			1-1	1-2	1-3	1-4	1-5	1-6	1-7	1-8
			Disc Air A	Disc Air B	Disc Air C	Disc Air D	DefTerm A	DefTerm B	DefTerm C	DefTerm D
			DO Points (Base Module)							
			1-12	1-13	1-14	1-15	1-16	1-17	1-18	1-19
2		4 Case LnUp MT C	AI Points (Base Module)							
			1-1	1-2	1-3	1-4	1-5	1-6	1-7	1-8
			Disc Air A	Disc Air B	Disc Air C	Disc Air D				
			DO Points (Base Module)							
			1-12	1-13	1-14	1-15	1-16	1-17	1-18	1-19
3		4 EEV LT	AI Points (Base Module)							
			1-1	1-2	1-3	1-4	1-5	1-6	1-7	1-8
			Disc Air A	Evap Out A	DefTerm A	Disc Air B	Evap Out B	DefTerm B	Disc Air C	Evap Out C
			DO Points (Base Module)							
			1-12	1-13	1-14	1-15	1-16	1-17	1-18	1-19
4		4 EEV LT I Term	AI Points (Base Module)							
			1-1	1-2	1-3	1-4	1-5	1-6	1-7	1-8
			Disc Air A	Evap Out A	DefTerm A	Disc Air B	Evap Out B	DefTerm B	Disc Air C	Evap Out C
			DO Points (Base Module)							
			1-12	1-13	1-14	1-15	1-16	1-17	1-18	1-19
5	Unconnected DOs (OK)	4 EEV LT NoTerm	AI Points (Base Module)							
			1-1	1-2	1-3	1-4	1-5	1-6	1-7	1-8
			Disc Air A	Evap Out A	Disc Air B	Evap Out B	Disc Air C	Evap Out C	Disc Air D	Evap Out D
			DO Points (Base Module)							
			1-12	1-13	1-14	1-15	1-16	1-17	1-18	1-19
6		4 EEV LT C Term DI	AI Points (Base Module)							
			1-1	1-2	1-3	1-4	1-5	1-6	1-7	1-8
			Disc Air A	Evap Out A	DI Term A	Disc Air B	Evap Out B	DI Term B	Disc Air C	Evap Out C
			DO Points (Base Module)							
			1-12	1-13	1-14	1-15	1-16	1-17	1-18	1-19
7		4 EEV LT I Term DI	AI Points (Base Module)							
			1-1	1-2	1-3	1-4	1-5	1-6	1-7	1-8
			Disc Air A	Evap Out A	DI Term A	Disc Air B	Evap Out B	DI Term B	Disc Air C	Evap Out C
			DO Points (Base Module)							
			1-12	1-13	1-14	1-15	1-16	1-17	1-18	1-19

	1-9	1-10	1-11								
	Door Sw										
	Power Module Connector										
	1-20	1-21	1-22	1-23							
	ASH	Light	Def	Fan							
	1-9	1-10	1-11								
	Door Sw										
	Power Module Connector										
	1-20	1-21	1-22	1-23							
	ASH	Light	Def	Fan							
	AI Point (Expansion Module)										
	1-9	1-10	1-11	2-1	2-2	2-3	2-4	2-5	2-6	2-7	2-8
	Def Term C	PE Pressure	Door Sw	Disc Air D	Evap Out D	Def Term D	Dual-Temp				
	DO Point (Expansion Module)										
				2-9	2-10	2-11	2-12	2-13	2-14	2-15	2-16
	AI Point (Expansion Module)										
	1-9	1-10	1-11	2-1	2-2	2-3	2-4	2-5	2-6	2-7	2-8
	Def Term C	PE Pressure	Door Sw	Disc Air D	Evap Out D	Def Term D					
	DO Point (Expansion Module)										
				2-9	2-10	2-11	2-12	2-13	2-14	2-15	2-16
				Def B	Def C	Def D					
	1-9	1-10	1-11								
	Dual Temp	PE Pressure	Door Sw								
	AI Point (Expansion Module)										
	1-9	1-10	1-11	2-1	2-2	2-3	2-4	2-5	2-6	2-7	2-8
	DI Term C	PE Pressure	Door Sw	Disc Air D	Evap Out D	DI Term D	Dual-Temp				
	DO Point (Expansion Module)										
				2-9	2-10	2-11	2-12	2-13	2-14	2-15	2-16
	AI Point (Expansion Module)										
	1-9	1-10	1-11	2-1	2-2	2-3	2-4	2-5	2-6	2-7	2-8
	DI Term C	PE Pressure	Door Sw	Disc Air D	Evap Out D	DI Term D	Dual-Temp				
	DO Point (Expansion Module)										
				2-9	2-10	2-11	2-12	2-13	2-14	2-15	2-16
				Def B	Def C	Def D					

8		4 EEV LT CPM	AI Points (Base Module)							
			1-1	1-2	1-3	1-4	1-5	1-6	1-7	1-8
			Disc Air A	Evap Out A	Def Term A	Disc Air B	Evap Out B	Def Term B	Disc Air C	Evap Out C
			DO Points (Base Module)							
			1-12	1-13	1-14	1-15	1-16	1-17	1-18	1-19
			EEV A	EEV B	EEV C	EEV D				
9	Unconnected DOs (OK)	4 EEV LT CPM NoT	AI Points (Base Module)							
			1-1	1-2	1-3	1-4	1-5	1-6	1-7	1-8
			Disc Air A	Evap Out A	Disc Air B	Evap Out B	Disc Air C	Evap Out C	Disc Air D	Evap Out D
			DO Points (Base Module)							
			1-12	1-13	1-14	1-15	1-16	1-17	1-18	1-19
			EEV A	EEV B	EEV C	EEV D				
10	Unconnected DOs (OK)	4 EEV MT	AI Points (Base Module)							
			1-1	1-2	1-3	1-4	1-5	1-6	1-7	1-8
			Disc Air A	Evap Out A	Disc Air B	Evap Out B	Disc Air C	Evap Out C	Disc Air D	Evap Out D
			DO Points (Base Module)							
			1-12	1-13	1-14	1-15	1-16	1-17	1-18	1-19
			EEV A	EEV B	EEV C	EEV D	Fan	Light		
						Def				
11	Unconnected DOs (OK)	4 EEV MT CPM	AI Points (Base Module)							
			1-1	1-2	1-3	1-4	1-5	1-6	1-7	1-8
			Disc Air A	Evap Out A	Disc Air B	Evap Out B	Disc Air C	Evap Out C	Disc Air D	Evap Out D
			DO Points (Base Module)							
			1-12	1-13	1-14	1-15	1-16	1-17	1-18	1-19
			EEV A	EEV B	EEV C	EEV D				
12		4 EEV Comm Term	AI Points (Base Module)							
			1-1	1-2	1-3	1-4	1-5	1-6	1-7	1-8
			Disc A	Dt A	Disc B	Dt B	Disc C	Dt C	Disc D	Dt D
			DO Points (Base Module)							
			1-12	1-13	1-14	1-15	1-16	1-17	1-18	1-19
			Valve A	Valve B	Valve C	Valve D	Fan	Light		
						DEF	ASH			
13		4 EEV Ind Term	AI Points (Base Module)							
			1-1	1-2	1-3	1-4	1-5	1-6	1-7	1-8
			Disc A	Dt A	Disc B	Dt B	Disc C	Dt C	Disc D	Dt D
			DO Points (Base Module)							
			1-12	1-13	1-14	1-15	1-16	1-17	1-18	1-19
			Valve A	Valve B	Valve C	Valve D	Fan	Light		
						Def A	ASH			
14		4 EEV AD C Term	AI Points (Base Module)							
			1-1	1-2	1-3	1-4	1-5	1-6	1-7	1-8
			Disc A	Dt A	Disc B	Dt B	Disc C	Dt C	Disc D	Dt D
			DO Points (Base Module)							
			1-12	1-13	1-14	1-15	1-16	1-17	1-18	1-19
			Valve A	Valve B	Valve C	Valve D	Fan	Light		
						DEF	ASH			
15		4 EEV AD I Term	AI Points (Base Module)							
			1-1	1-2	1-3	1-4	1-5	1-6	1-7	1-8
			Disc A	Dt A	Disc B	Dt B	Disc C	Dt C	Disc D	Dt D
			DO Points (Base Module)							
			1-12	1-13	1-14	1-15	1-16	1-17	1-18	1-19
			Valve A	Valve B	Valve C	Valve D	Fan	Light		
						Def A	ASH			
16		4 EEV DT C Term	AI Points (Base Module)							
			1-1	1-2	1-3	1-4	1-5	1-6	1-7	1-8
			Disc Air A	Evap Out A	Def Term A	Dual Temp A	Disc Air B	Evap Out B	Def Term B	Dual Temp B
			DO Points (Base Module)							
			1-12	1-13	1-14	1-15	1-16	1-17	1-18	1-19
			EEV A	EEV B	EEV C	EEV D	Fan	Light		
						Def	ASH			
17		4 EEV DT I Term	AI Points (Base Module)							
			1-1	1-2	1-3	1-4	1-5	1-6	1-7	1-8
			Disc Air A	Evap Out A	Def Term A	Dual Temp A	Disc Air B	Evap Out B	Def Term B	Dual Temp B
			DO Points (Base Module)							
			1-12	1-13	1-14	1-15	1-16	1-17	1-18	1-19
			EEV A	EEV B	EEV C	EEV D	Fan	Light		
						Def A	ASH			

				AI Point (Expansion Module)							
1-9	1-10	1-11		2-1	2-2	2-3	2-4	2-5	2-6	2-7	
DefTerm C	PE Pressure	Door Sw		Disc Air D	Evap Out D	DefTerm D	Dual - Temp				
Power Module Connector				DO Point (Expansion Module)							
1-20	1-21	1-22	1-23	2-9	2-10	2-11	2-12	2-13	2-14	2-15	
ASH	Light	Def	Fan								
1-9	1-10	1-11									
	Dual Temp	PE Pressure	Door Sw								
Power Module Connector											
1-20	1-21	1-22	1-23								
ASH	Light	Def	Fan								
1-9	1-10	1-11									
		PE Pressure	Door Sw								
1-9	1-10	1-11									
		PE Pressure	Door Sw								
Power Module Connector											
1-20	1-21	1-22	1-23								
ASH	Light	Def	Fan								
				AI Point (Expansion Module)							
1-9	1-10	1-11	2-1	2-2	2-3	2-4	2-5	2-6	2-7	2-8	
		PE	dr Sw				EpO A	EpO B	EpO C	EpO D	
				DO Point (Expansion Module)							
			2-9	2-10	2-11	2-12	2-13	2-14	2-15	2-16	
			----	----	----	----	----	----	----	----	
				AI Point (Expansion Module)							
1-9	1-10	1-11	2-1	2-2	2-3	2-4	2-5	2-6	2-7	2-8	
		PE	dr Sw				EpO A	EpO B	EpO C	EpO D	
				DO Point (Expansion Module)							
			2-9	2-10	2-11	2-12	2-13	2-14	2-15	2-16	
			Def B	Def C	Def D	----	----	----	----	----	
				AI Point (Expansion Module)							
1-9	1-10	1-11	2-1	2-2	2-3	2-4	2-5	2-6	2-7	2-8	
Rt A	PE	dr Sw	Rt B	Rt C	Rt D	EpO A	EpO B	EpO C	EpO D	----	
				DO Point (Expansion Module)							
			2-9	2-10	2-11	2-12	2-13	2-14	2-15	2-16	
			----	----	----	----	----	----	----	----	
				AI Point (Expansion Module)							
1-9	1-10	1-11	2-1	2-2	2-3	2-4	2-5	2-6	2-7	2-8	
Rt A	PE	dr Sw	Rt B	Rt C	Rt D	EpO A	EpO B	EpO C	EpO D	----	
				DO Point (Expansion Module)							
			2-9	2-10	2-11	2-12	2-13	2-14	2-15	2-16	
			Def B	Def C	Def D	----	----	----	----	----	
				AI Point (Expansion Module)							
1-9	1-10	1-11	2-1	2-2	2-3	2-4	2-5	2-6	2-7	2-8	
Disc Air C	Pe pressure	Door Sw	Evap Out C	DefTerm C	Dual Temp C	Disc Air D	Evap Out D	DefTerm D	Dual Temp D		
				DO Point (Expansion Module)							
			2-9	2-10	2-11	2-12	2-13	2-14	2-15	2-16	
				AI Point (Expansion Module)							
1-9	1-10	1-11	2-1	2-2	2-3	2-4	2-5	2-6	2-7	2-8	
Disc Air C	Pe pressure	Door Sw	Evap Out C	DefTerm C	Dual Temp C	Disc Air D	Evap Out D	DefTerm D	Dual Temp D		
				DO Point (Expansion Module)							
			2-9	2-10	2-11	2-12	2-13	2-14	2-15	2-16	
			Def B	Def C	Def D						

18		4 LLSV LT	AI Points (Base Module)							
			1-1	1-2	1-3	1-4	1-5	1-6	1-7	1-8
			Disc Air A	Def Term A	Disc Air B	Def Term B	Disc Air C	Def Term C	Disc Air D	Def Term D
			DO Points (Base Module)							
			1-12	1-13	1-14	1-15	1-16	1-17	1-18	1-19
			Valve A	Valve B	Valve C	Valve D	Fan	Light	Def	ASH
19		4 LLSV LT I Term	AI Points (Base Module)							
			1-1	1-2	1-3	1-4	1-5	1-6	1-7	1-8
			Disc Air A	Def Term A	Disc Air B	Def Term B	Disc Air C	Def Term C	Disc Air D	Def Term D
			DO Points (Base Module)							
			1-12	1-13	1-14	1-15	1-16	1-17	1-18	1-19
			Valve A	Valve B	Valve C	Valve D	Fan	Light	Def A	ASH
20		4 LLSV LT C Term DI	AI Points (Base Module)							
			1-1	1-2	1-3	1-4	1-5	1-6	1-7	1-8
			Disc Air A	DI Term A	Disc Air B	DI Term B	Disc Air C	DI Term C	Disc Air D	DI Term D
			DO Points (Base Module)							
			1-12	1-13	1-14	1-15	1-16	1-17	1-18	1-19
			Valve A	Valve B	Valve C	Valve D	Fan	Light	Def	ASH
21		4 LLSV LT I Term DI	AI Points (Base Module)							
			1-1	1-2	1-3	1-4	1-5	1-6	1-7	1-8
			Disc Air A	DI Term A	Disc Air B	DI Term B	Disc Air C	DI Term C	Disc Air D	DI Term D
			DO Points (Base Module)							
			1-12	1-13	1-14	1-15	1-16	1-17	1-18	1-19
			Valve A	Valve B	Valve C	Valve D	Fan	Light	Def A	ASH
22		4 LLSV MT	AI Points (Base Module)							
			1-1	1-2	1-3	1-4	1-5	1-6	1-7	1-8
			Disc Air A		Disc Air B		Disc Air C		Disc Air D	
			DO Points (Base Module)							
			1-12	1-13	1-14	1-15	1-16	1-17	1-18	1-19
			Valve A	Valve B	Valve C	Valve D	Fan	Light	ASH	
23		4 LLSV DT C Term	AI Points (Base Module)							
			1-1	1-2	1-3	1-4	1-5	1-6	1-7	1-8
			Disc Air A	Def Term A	Dual Temp A	Disc Air B	Def Term B	Dual Temp B	Disc Air C	Def Term C
			DO Points (Base Module)							
			1-12	1-13	1-14	1-15	1-16	1-17	1-18	1-19
			Valve A	Valve B	Valve C	Valve D	Fan	Light	Def	ASH
24		4 LLSV DT I Term	AI Points (Base Module)							
			1-1	1-2	1-3	1-4	1-5	1-6	1-7	1-8
			Disc Air A	Def Term A	Dual Temp A	Disc Air B	Def Term B	Dual Temp B	Disc Air C	Def Term C
			DO Points (Base Module)							
			1-12	1-13	1-14	1-15	1-16	1-17	1-18	1-19
			Valve A	Valve B	Valve C	Valve D	Fan	Light	Def A	ASH

	1-9	1-10	1-11								
		Dual Temp	Door Sw								
				AI Point (Expansion Module)							
	1-9	1-10	1-11	2-1	2-2	2-3	2-4	2-5	2-6	2-7	2-8
			Door Sw								
				DO Point (Expansion Module)							
				2-9	2-10	2-11	2-12	2-13	2-14	2-15	2-16
				Def B	Def C	Def D					
	1-9	1-10	1-11								
		Dual Temp	Door Sw								
				AI Point (Expansion Module)							
	1-9	1-10	1-11	2-1	2-2	2-3	2-4	2-5	2-6	2-7	2-8
		Dual Temp	Door Sw								
				DO Point (Expansion Module)							
				2-9	2-10	2-11	2-12	2-13	2-14	2-15	2-16
				Def B	Def C	Def D					
	1-9	1-10	1-11								
			Door Sw								
				AI Point (Expansion Module)							
	1-9	1-10	1-11	2-1	2-2	2-3		2-5	2-6	2-7	2-8
	Dual Temp C	Disc Air D	Def Term D	Dual Temp D	Door Alarm						
				DO Point (Expansion Module)							
				2-9	2-10	2-11	2-12	2-13	2-14	2-15	2-16
				AI Point (Expansion Module)							
	1-9	1-10	1-11	2-1	2-2	2-3		2-5	2-6	2-7	2-8
	Dual Temp C	Disc Air D	Def Term D	Dual Temp D	Door Alarm						
				DO Point (Expansion Module)							
				2-9	2-10	2-11	2-12	2-13	2-14	2-15	2-16
				Def B	Def C	Def D					

