

Design Guide

# Capacity controller AK-PC 710

ADAP-KOOL® Refrigeration control systems

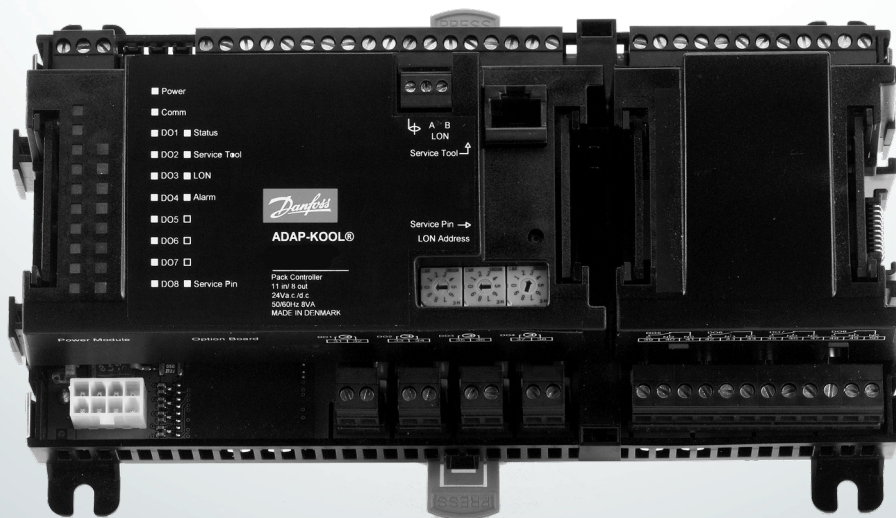

# Contents

<b>1. Introduction .....</b>	<b>3</b>	<b>5. Regulating functions .....</b>	<b>73</b>
Application .....	3	Suction group .....	74
Function overview .....	3	Controlling sensor .....	74
Principles .....	4	Reference .....	74
<b>2. Design of the controller .....</b>	<b>7</b>	Capacity control of compressors .....	75
Module survey .....	8	Capacity distribution methods .....	76
Common data for modules .....	10	Power pack types – compressor combinations .....	77
Controller .....	12	Compressor timers .....	79
Extension module AK-XM 102A / AK-XM 102B .....	14	Load shedding .....	80
Extension module AK-XM 204A / AK-XM 204B .....	16	Injection ON .....	80
Extension module AK-OB 110 .....	18	Safety functions .....	81
Extension module AK-OB 101A .....	19	Condenser .....	82
Extension module EKA 163B / EKA 164B / EKA 166 .....	20	Capacity control of condenser .....	82
Power supply module AK-PS 075 .....	21	Reference for condensing pressure .....	82
Select application .....	22	Capacity distribution .....	84
General .....	22	Step regulation .....	84
Applications .....	22	Speed regulation .....	84
Ordering .....	33	Condenser couplings .....	84
<b>3. Mounting and wiring .....</b>	<b>35</b>	Safety functions for condenser .....	85
Mounting .....	36	Separate monitoring functions .....	85
Mounting of analog output module .....	36	Miscellaneous .....	86
Mounting of extension module on the basic module .....	37	Appendix A – Compressor combinations and coupling pat-	
Wiring .....	38	terns .....	89
<b>4. Configuration and operation .....</b>	<b>39</b>		
Configuration via service tool AK-ST 500 .....	41		
Connect PC or PDA .....	41		
Authorization .....	42		
Unlock the configuration of the controllers .....	43		
System setup .....	44		
Set plant type .....	45		
Set control of compressors .....	46		
Setup control of condenser .....	49		
Configuration of inputs and outputs .....	50		
Set alarm priorities .....	52		
Lock configuration .....	54		
Check configuration .....	55		
Check of connections .....	57		
Check of settings .....	59		
Schedule function .....	61		
Installation in network .....	62		
First start of control .....	63		
Start the control .....	64		
Manual capacity control .....	65		
Quick setup .....	66		
EKA 164, EKA 166 or AKM operation .....	67		

# 1. Introduction

## Application

AK-PC 710 is a complete regulating unit for capacity control of compressors and condensers in refrigeration systems. In addition to capacity control the controllers can give signals to other controllers about the operating condition, e.g. forced closing of expansion valves, alarm signals and alarm messages.

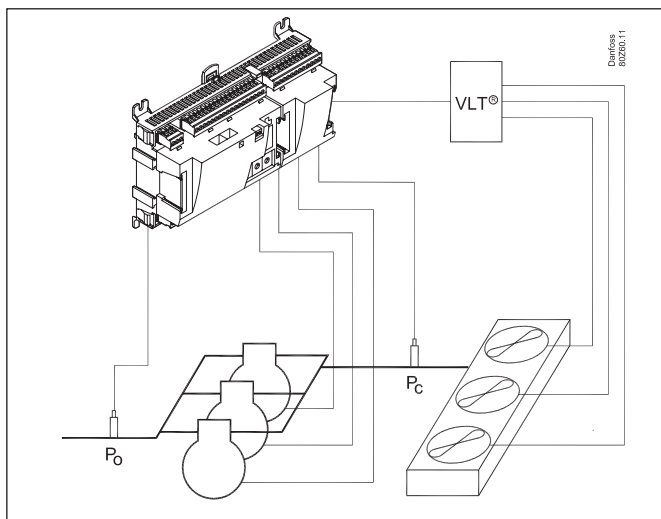

The controller's main function is to control compressors and condensers so that operation all the time takes place at the energy-optimum pressure conditions. Both suction pressure and condensing pressure are controlled by signals from pressure transmitters.

Capacity control can be carried out by suction pressure P0.

Among the different functions are:

- Capacity control of up to 6 compressors
- Speed control of one compressor
- One safety input for each compressor
- Option for capacity limitation to minimize consumption peaks
- When the compressor stops, signals can be transmitted to appliance controllers so that the electronic expansion valves will be closed (signal via data communication)
- Safety monitoring of high pressure / low pressure / discharge temperature
- Capacity control of up to 6 fans
- Step coupling, speed regulation or a combination
- Floating reference with regard to outside temperature
- Safety monitoring of fans
- The status of the outputs and inputs is shown by means of light-emitting diodes on the front panel
- Alarm signals can be generated directly from the controller and via data communication
- Alarms are shown with texts so that the cause of the alarm is easy to see.
- Plus some completely separate functions that are totally independent of the regulation – such monitoring of liquid level and room temperature.

## Function overview

	AK-PC 710
<b>Application</b>	
Regulation of a compressor group	x
Both compressor group and condenser group	x
<b>Regulation of compressor capacity</b>	
Regulation sensor	P0
PI-regulation	x
Max. number of compressor steps	6
Identical compressor capacities	x
Different compressor capacities	x
Sequential operation (first in / last out)	x
Speed regulation of 1 compressor	x
Run time equalisation	x
Min. restart time	x
Min. On-time/ Min Off time	x
<b>Suction pressure reference</b>	
Override via P0 optimization	x
Override via "night setback"	x
<b>Regulation of condenser capacity</b>	
Regulation sensor	Pc
Step regulation	x
Max. number of steps	6
Speed regulation	x
Step and speed regulation	x
<b>Condenser pressure reference</b>	
Floating condensing pressure reference	x
<b>Safety functions</b>	
Min. suction pressure	x
Max. suction pressure	x
Max. condensing pressure	x
Max. discharge gas temperature	x
Min. / Max. superheat	x
Safety monitoring of compressors	x
Common high pressure monitoring of compressors	x
Common low pressure monitoring of compressors	x
Safety monitoring of condenser fans	x
Monitoring of room temperature	x
Monitoring of liquid level	x
Monitoring of frequency converter (VSD)	x
<b>Miscellaneous</b>	
Inject On function via data communication	x
Option for connection of separate display	2
Option for connection of graphic display	1

# Principles

The great advantage of this series of controllers is that it can be extended as the size of the plant is increased. It has been developed for refrigeration control systems, but not for any specific application – variation is created through the read-in software and extension with up to 3 modules.

It is the same modules that are used for each regulation and the composition can be changed, as required. With these modules (building blocks) there is up to 40 various kinds of regulations. But it is you who must help adjusting the regulation to the actual needs – these instructions will assist you to find your way through all the questions so that the regulation can be defined and the connections made.

## Advantages

- The controller's size can "grow" as systems grow
- The software can be set for one or more regulations
- Several regulations with the same components
- Extension-friendly when systems requirements are changed
- Flexible concept:
  - Controller series with common construction
  - One principle – many regulation uses
  - modules are selected for the actual connection requirements
  - The same modules are used from regulation to regulation

**Controller**

Danfoss  
80792.11

Top part

Bottom part

**Extension modules**

Danfoss  
80793.10

The controller is the cornerstone of the regulation. The module has inputs and outputs capable of handling small systems.

- The bottom part – and hence the terminals – are the same for all controller types.
- The top part contains the intelligence with software. This unit will vary according to controller type. But it will always be supplied together with the bottom part.
- In addition to the software the top part is provided with connections for data communication and address setting.

If the system grows and more functions have to be controlled, the regulation can be extended. With extra modules more signals can be received and more relays cut in and out – how many of them – and which – is determined by the relevant application.

---

**Examples**

Danfoss  
860295.10

Danfoss  
860295.10

Danfoss  
860294.10

A regulation with few connections can be performed with the controller module alone

If there are many connections one or more extension modules must be mounted



### Direct connection

Setup and operation of an AK controller must be accomplished via the "AK-Service Tool" software program.

The programme is installed on a PC, and setup and operation of the various functions are carried out via the controller's menu displays.

### Displays

The menu displays are dynamic, so that different settings in one menu will result in different setting possibilities in other menus.

A simple application with few connections will give a setup with few settings.

A corresponding application with many connections will give a setup with many settings.

From the overview display there is access to further displays for the compressor regulation and the condenser regulation.

At the bottom of the display there is access to a number of general functions, such as "time table", "manual operation", "log function", "alarms", and "service" (configuration).

### Network linking

The controller can be linked up into a network together with other controllers in an ADAP-KOOL® refrigeration control system. After the setup operation can be performed at a distance with, say, our software program type AKM.

### Users

The controller comes supplied with several languages, one of which can be selected and employed by the user. If there are several users, they may each have their choice of language. All users must be assigned a user profile which either gives access to full operation or gradually limits the operation to the lowest level that only allows you "to see".

### External display

An external display can be fitted in order for P0 (Suction) and Pc (Condensing) readings to be displayed.

The setup can be carried out on a display with control buttons. The various functions are selected via a menu system.

If display of operational compressors, fans and functions is required, display type EKA 166 can be fitted.

Med det grafiske display AK-MMI kan der både foretages opsætning og udlæsning.

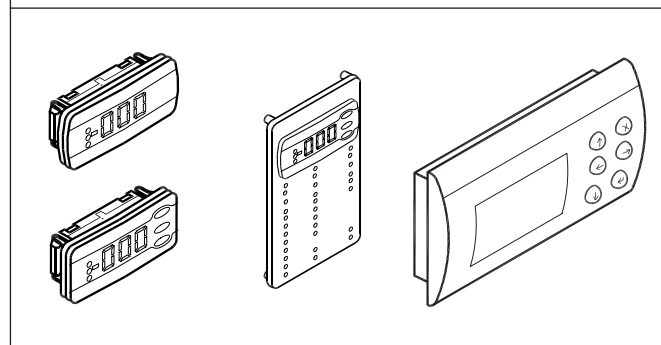
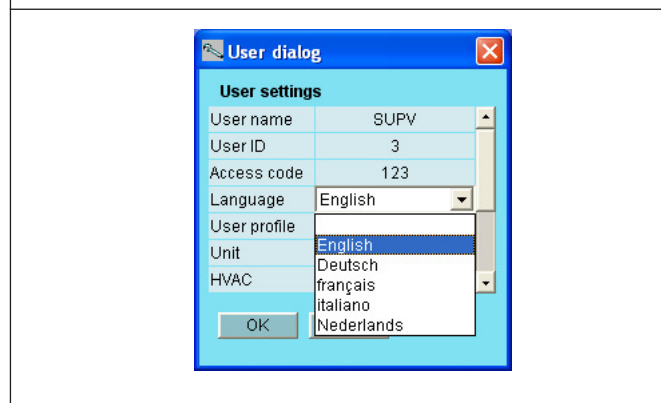
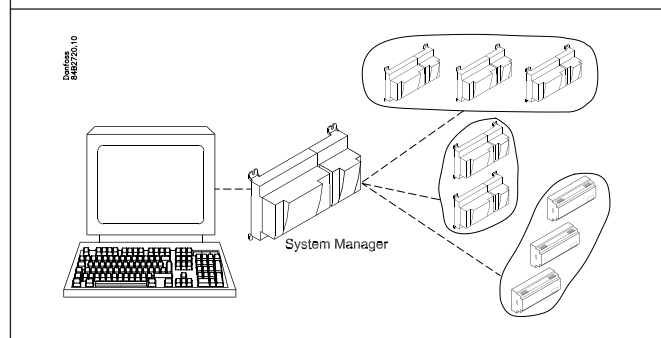
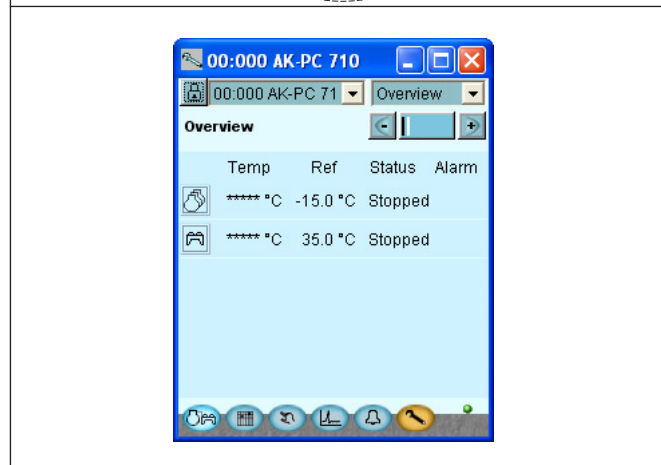
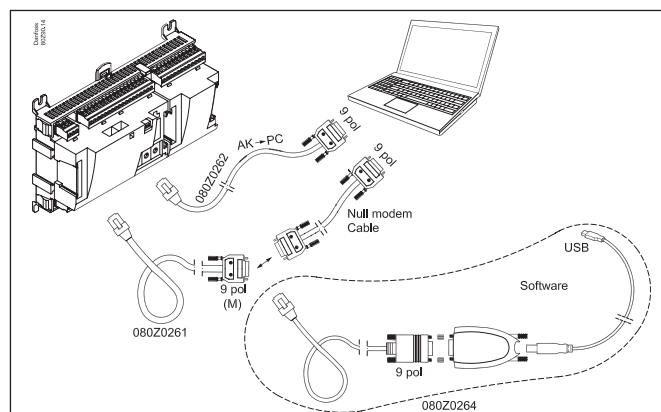

### Light-emitting diodes

A number of light-emitting diodes makes it possible to follow the signals that are received and transmitted by the controller.

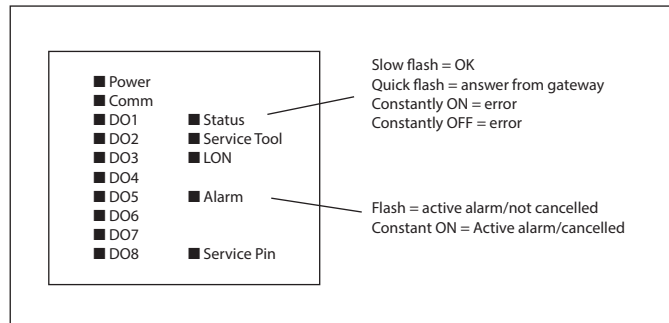

### Log

From the log function you can define the measurements you wish to be shown.

The collected values can be printed, or you may export them to a file. You can open the file in Excel.

If you are in a service situation you can show measurements in a trend function. The measurements are then made real-time and displayed instantly.

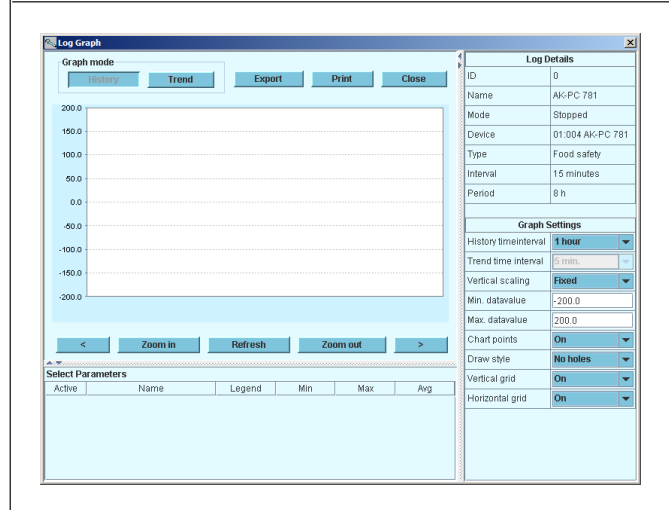

### Alarm

The display gives you an overview of all active alarms. If you wish to confirm that you have seen the alarm you can cross it off in the acknowledge field.

If you want to know more about a current alarm you can click on it and obtain an information display on the screen.

A corresponding display exists for all earlier alarms. Here you can upload information if you need further details about the alarm history.

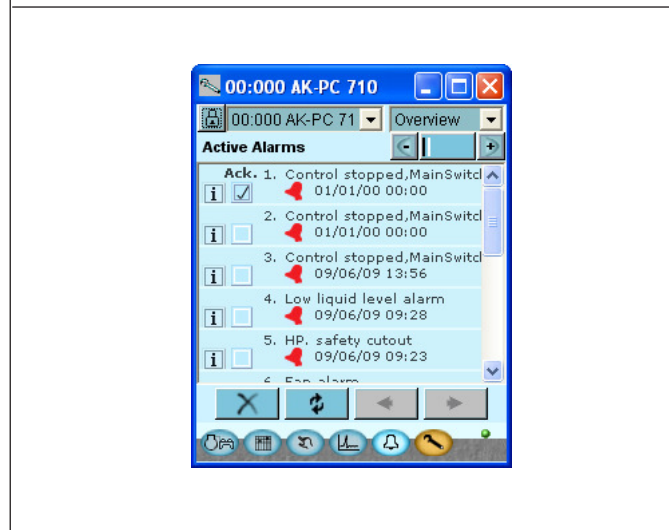

---

## 2. Design of the controller

---

This controller can be configured to one of the 40 fixed applications.

- There are 20 applications with different numbers of compressors and condenser fans.
- The same applications can also be carried out with speed control of one compressor.
- The condenser fans can be connected in steps or speed controlled.

The selected application has fixed defined connecting points. These cannot be changed.

In addition to the controller module, one or more of the following modules should be used. The selected application determines:

- Output module with relays
- Input module for registering on/off signals
- Analogue output module for controlling one or two frequency converters. One for one compressor and one for the condenser fans.

This section defines the application and which modules should be used.

# Module survey

- Controller module – capable of handling minor plant requirements.
- Extension modules. When the complexity becomes greater and additional inputs or outputs are required, modules can be attached to the controller. A plug on the side of the module will transmit the supply voltage and data communication between the modules.
- Top part  
The upper part of the controller module contains the intelligence. This is the unit where the regulation is defined and where data communication is connected to other controllers in a bigger network.
- Connection types  
There are various types of inputs and outputs. One type may, for example, receive signals from sensors and switches, another may receive a voltage signal, and a third type may be outputs with relays etc. The individual types are shown in the table below.
- Fixed connection  
When a regulation is planned (set up) it will generate a need for a number of connections distributed on the mentioned types. This connection must be made as shown in the following diagrams.

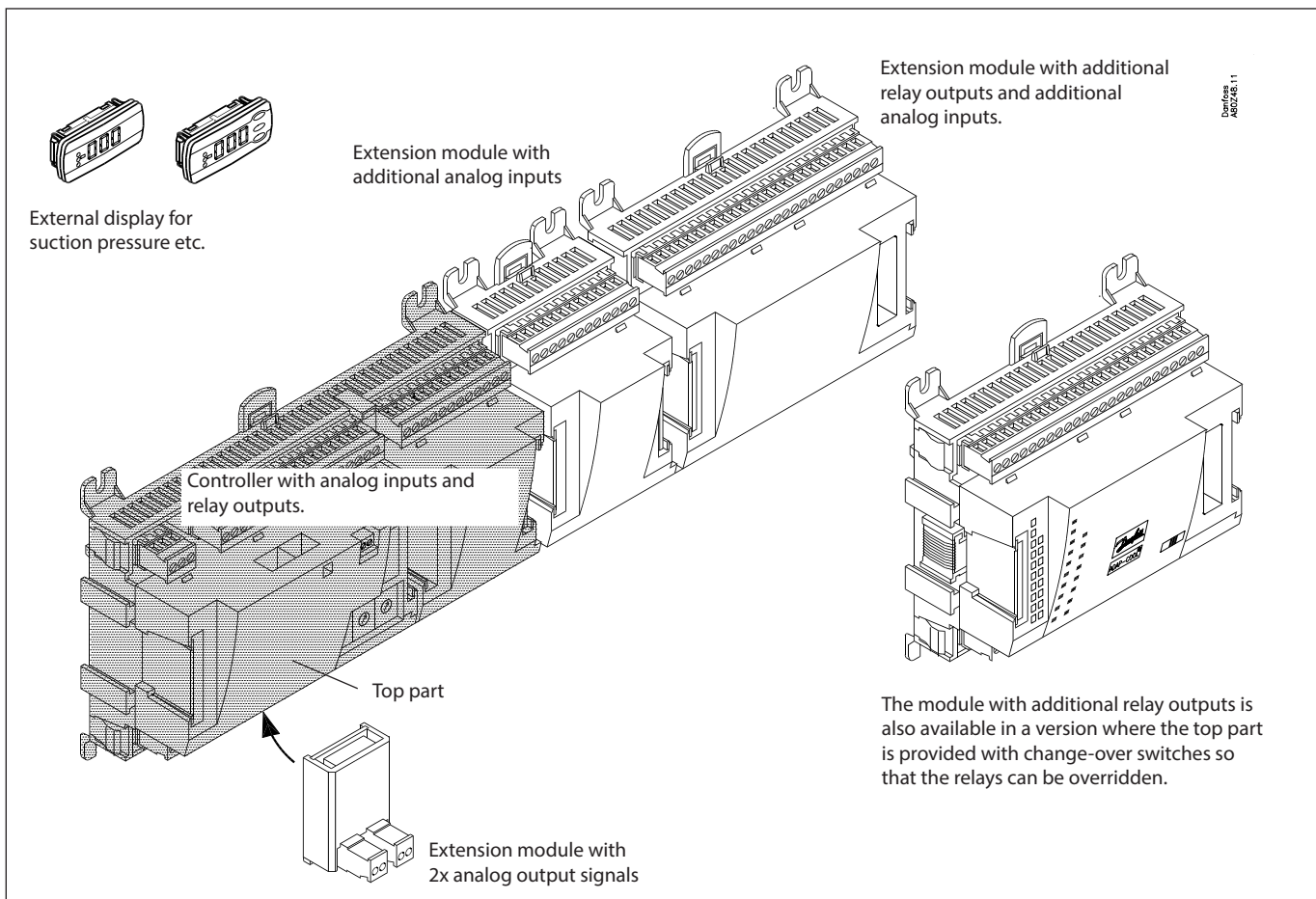

### 1. Controller

Type	Function	Application
AK-PC 710	Controller for capacity control of up to 6 compressors and up to 6 condenser fans	Compressor / Condenser / Both

### 2. Extension modules and survey of inputs and outputs

Type	Analog inputs	On/Off outputs		On/off supply voltage (DI signal)		Analog outputs	Module with switches
	For sensors, pressure transmitters etc.	Relay (SPDT)	Solid state	Low voltage (max. 80 V)	High voltage (max. 260 V)	0-10 V d.c.	For override of relay outputs
Controller	11	4	4	-	-	-	-

#### Extension modules

AK-XM 102A				8			
AK-XM 102B					8		
AK-XM 204A		8					
AK-XM 204B		8					x
AK-OB 110						2	

### 3. AK operation and accessories

Type	Function	Application
<b>Operation</b>		
AK-ST 500	Software for operation of AK controllers	AK-operation
-	Cable between PC and AK controller	AK - Com port
-	Cable between zero modem cable and AK controller / Cable between PDA cable and AK controller	AK - RS 232
-	Cable between PC and AK controller	AK- USB
<b>Accessories</b>		
<b>Power supply module 230 V / 115 V to 24 V</b>		
AK-PS 075	18 VA	Supply for controller
<b>Accessories</b>		
<b>External display that can be connected to the controller module. For showing, say, the suction pressure</b>		
EKA 163B	Display	
EKA 164B	Display with operation buttons	
EKA 166	Display with operation buttons and LED's for inputs and outputs	
AK-MMI	Graphic display with operation	
-	Cable between display and controller	Length = 2 m, 6 m
	Cable between graphic display and controller	Length = 0.8 m, 1.5 m, 3 m
<b>Accessories</b>		
<b>Real time clock for use in controllers that require a clock function, but are not wired with data communication.</b>		
AK-OB 101A	Real time clock with battery backup.	To be mounted in an AK controller

On the following pages there is data specific to each module.

## Common data for modules

Supply voltage	24 V d.c./a.c. +/- 20%	
Power consumption	AK-__ (controller)	8 VA
	AK-XM 102	2 VA
	AK-XM 204	5 VA
Analog inputs	Pt 1000 ohm /0°C	Resolution: 0.1°C Accuracy: +/- 0.5°C
	Pressure transmitter type AKS 32R / AKS 32 (1-5 V)	Resolution: 1 mV Accuracy +/- 10 mV Max. connection of 5 pressure transmitters on one module
	Voltage signal 0-10 V	
	Contact function (On/Off)	On at R < 20 ohm Off at R > 2K ohm (Gold -plated contacts not necessary)
On/off supply voltage inputs	Low voltage 0 / 80 V a.c./d.c.	Off: U < 2 V On: U > 10 V
	High voltage 0 / 260 V a.c.	Off: U < 24 V On: U > 80 V
Relay outputs SPDT	AC-1 (ohmic)	4 A
	AC-15 (inductive)	3 A
	U	Min. 24 V Max. 230 V Low and high voltage must not be connected to the same output group
Solid state outputs	Used for control of compressor relay	Max. 240 V a.c. , Min. 48 V a.c. Max. 0.5 A, Leak < 1 mA
Ambient temperature	During transport	-40 to 70°C
	During operation	-20 to 55°C, 0 to 95% RH (non condensing) No shock influences / vibrations
Enclosure	Material	PC / ABS
	Class	IP10 , VBG 4
	Mounting	For mounting on panel wall or DIN rail
Weight with screw terminals	modules in 100- / 200- / controller-series	Ca. 200 g / 500 g / 600 g
Approvals	EU low voltage directive and EMC requirements are complied with	LVD tested according to EN 60730 EMC tested Immunity according to EN 61000-6-2 Emission according to EN 61000-6-3
	UL 873,  US	UL file number: E166834 for XM UL file number: E31024 for PC

The mentioned data applies to all modules.  
If data is specific, this is mentioned together with the module in question.

### Capacitive load

The relays cannot be used for the direct connection of capacitive loads such as LEDs and on/off control of EC motors.  
All loads with a switch mode power supply must be connected with a suitable contactor or similar.



## Dimensions

AK-PC 710

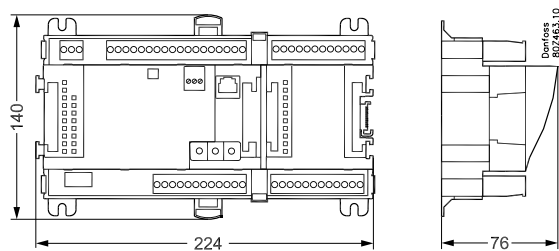

AK-PC 710 + AK-XM 102

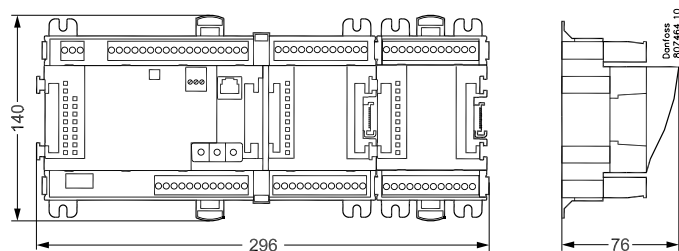

AK-PC 710 + AK-XM 204 + AK-XM 102

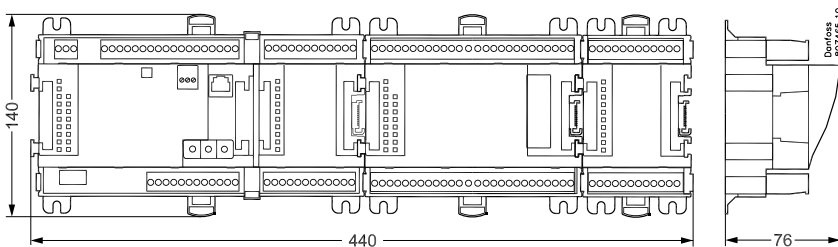

AK-PC 710 + AK-XM 204 + AK-XM 102 + AK-XM 102

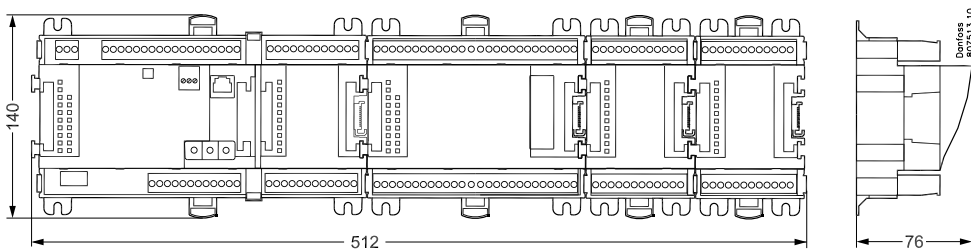

# Controller

## Function

There are several controllers in the series. The function is determined by the programmed software, but outwardly the controllers are identical – they all have the same connection possibilities:

- 11 analog inputs for sensors, pressure transmitters, voltage signals and contact signals.
- 8 digital outputs, with 4 Solid state outputs and 4 relay outputs

## Supply voltage

24 V a.c. or d.c. to be connected to the controller.

The 24 V must **not** be retransmitted and used by other controllers as it is not galvanically separated from inputs and outputs. In other words, you **must** use a transformer for each controller. Class II is required. The terminals must **not** be earthed.

The supply voltage to any extension modules is transmitted via the plug on the right-hand side.

The size of the transformer is determined by the power requirement of the total number of modules.

The supply voltage to a pressure transmitter can be taken either from the 5 V output or from the 12 V output depending on transmitter type.

## Data communication

If the controller is to be included in a system, communication must take place via the LON connection. The installation has to be made as mentioned in the separate instructions for LON communication.

## Address setting

When the controller is connected to a gateway type AKA 245, the controller's address must be set between 1 and 119. (If it is a system manager AK-SM .., then 1-999).

## Service PIN

When the controller is connected to the data communication cable the gateway must have knowledge of the new controller. This is obtained by pushing the key PIN. The LED "Status" will flash when the gateway sends an acceptance message.

## Operation

The configuration operation of the controller must take place from the software programme "Service Tool". The program must be installed on a PC, and the PC must be connected to the controller via the network plug on the front of the unit.

## Light-emitting diodes

There are two rows with LED's. They mean:

Left row:

- Voltage supply to the controller
- Communication active with the bottom PC board (red = error)
- Status of outputs DO1 to DO8

Right row:

- Software status (slow flash = OK)
- Communication with Service Tool
- Communication on LON
- Alarm when LED flashes
- 3 LED's that are not used
- "Service Pin" switch has been activated

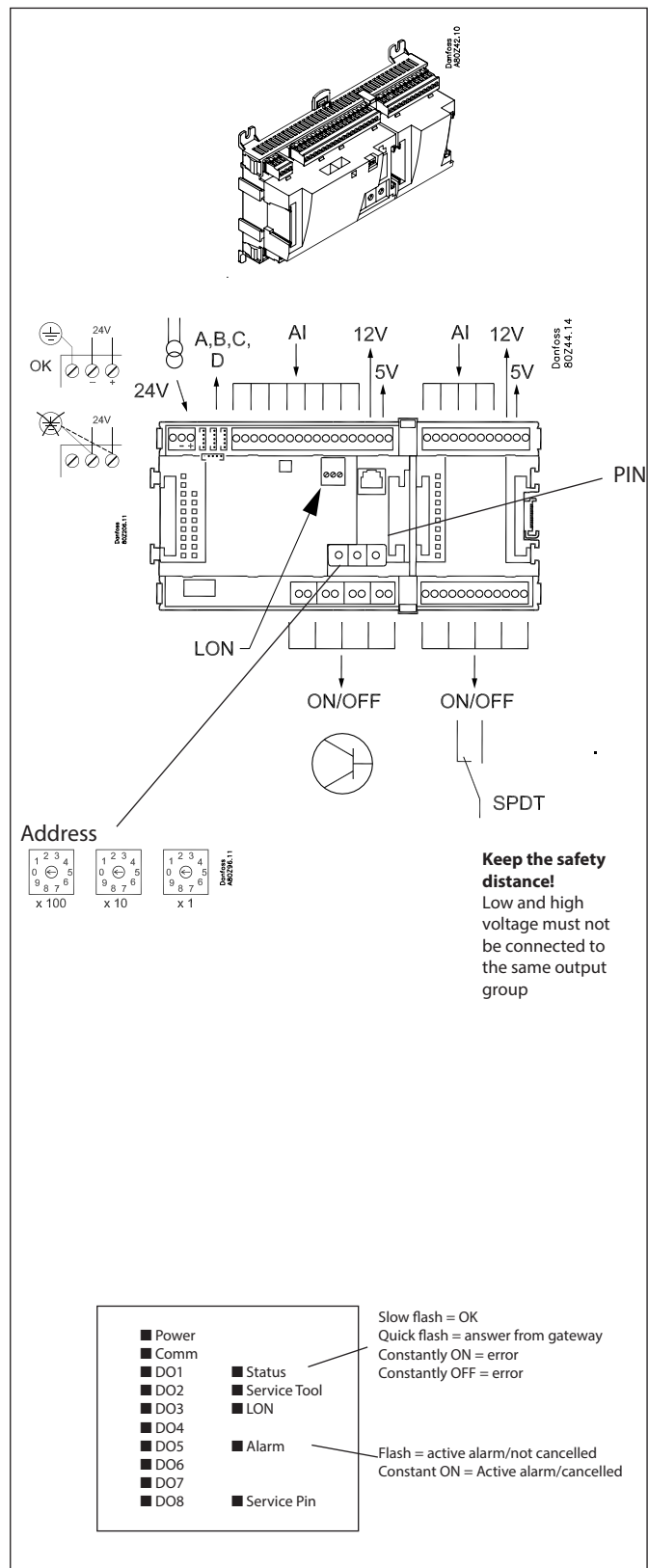

A small module (option board) can be placed on the bottom part of the controller. The module is described later in the document.

**Point**

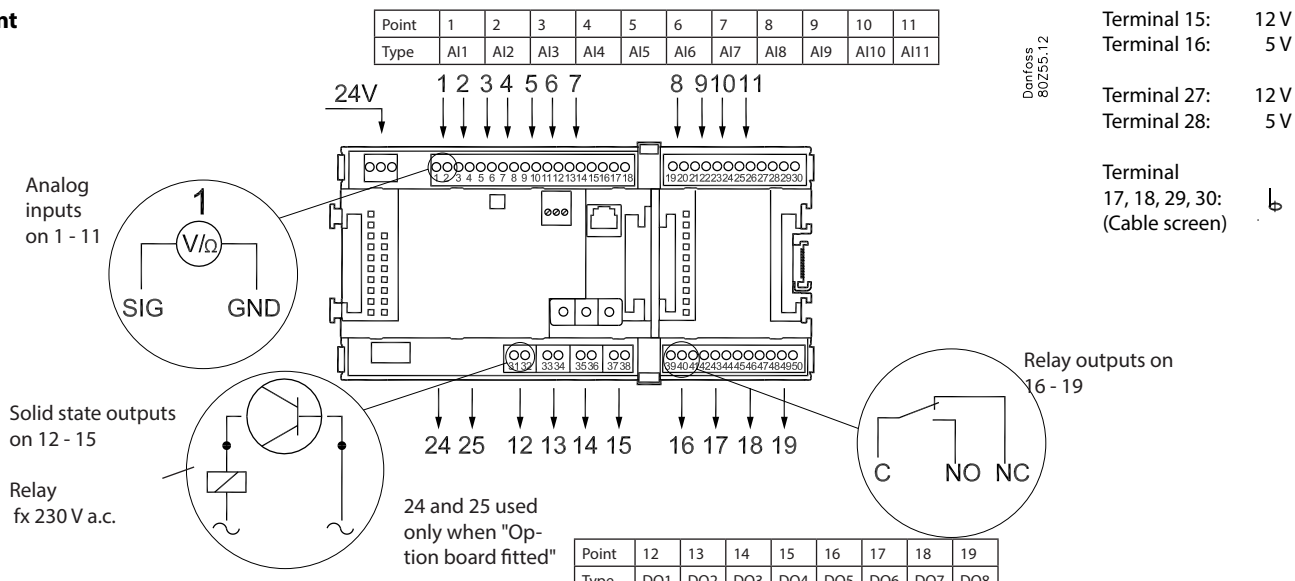

	Signal	Signal type
<b>S</b> Pt 1000 ohm/0°C	Saux1 Sc3 SS Sd	Pt 1000
<b>P</b> AKS 32R AKS 32	P0 Pc	AKS 32R/ AKS 2050 -1 - xx bar  AKS 32 -1 - zz bar
<b>On/Off</b>	Ext. Main switch Day/ Night PLP PHP LL	<b>Active at:</b> Closed / Open
<b>DO</b>	Comp 1-6 Fan 1 Alarm	<b>Active at:</b> On / Off
<b>Option Board</b>	Please see the signal on the page with the module.	

Signal	Module	Point	Terminal	Signal type / Active at
	<b>1</b>	1 (AI 1)	1 - 2	
		2 (AI 2)	3 - 4	
		3 (AI 3)	5 - 6	
		4 (AI 4)	7 - 8	
		5 (AI 5)	9 - 10	
		6 (AI 6)	11 - 12	
		7 (AI 7)	13 - 14	
		8 (AI 8)	19 - 20	
		9 (AI 9)	21 - 22	
		10 (AI 10)	23 - 24	
		11 (AI 11)	25 - 26	
		12 (DO 1)	31 - 32	
		13 (DO 2)	33 - 34	
		14 (DO 3)	35 - 36	
		15 (DO 4)	37 - 38	
		16 (DO 5)	39 - 40 - 41	
		17 (DO6)	42 - 43 - 44	
		18 (DO7)	45 - 46 - 47	
		19 (DO8)	48 - 49 - 50	
	24	-		
	25	-		

## Extension module AK-XM 102A / AK-XM 102B

### Function

The module contains 8 inputs for on/off voltage signals.

### Signal

AK-XM 102A is for low voltage signals.

AK-XM 102B is for high voltage signals.

### Supply voltage

The supply voltage to the module comes from the previous module in the row.

### Light-emitting diodes

They indicate:

- Voltage supply to the module
- Communication with the controller is active (red = error)
- Status of the individual inputs 1 to 8 (when lit = voltage)

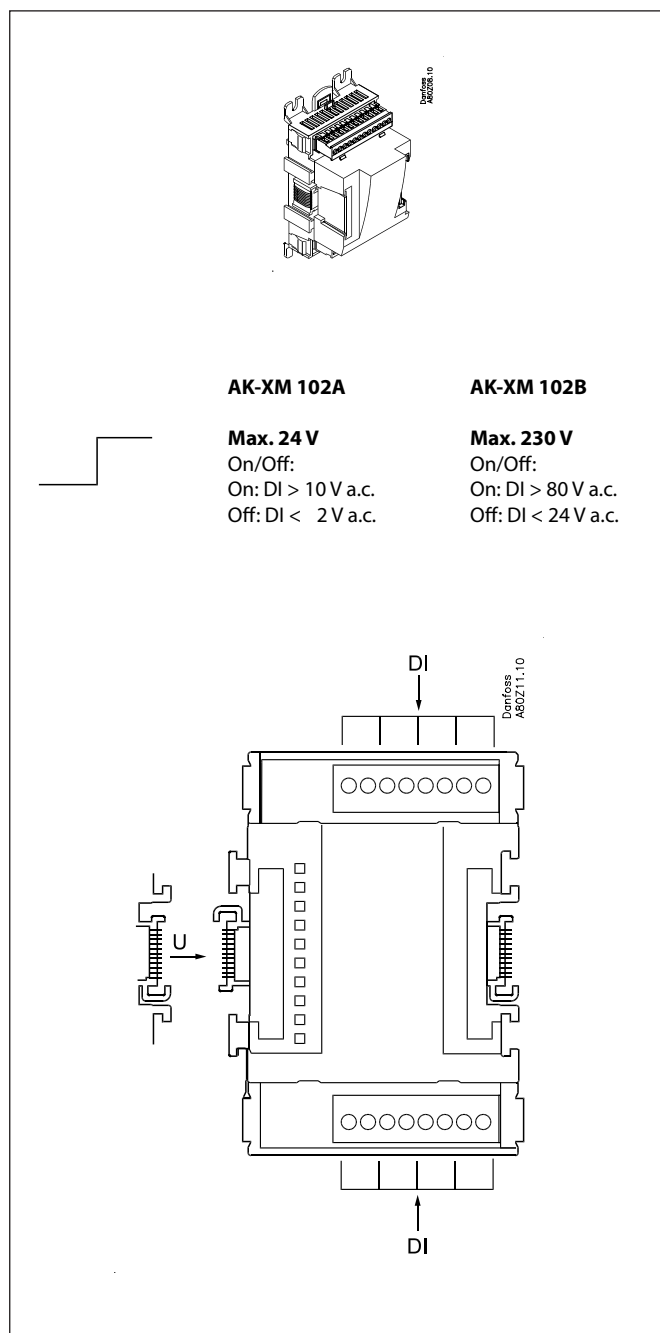

Point

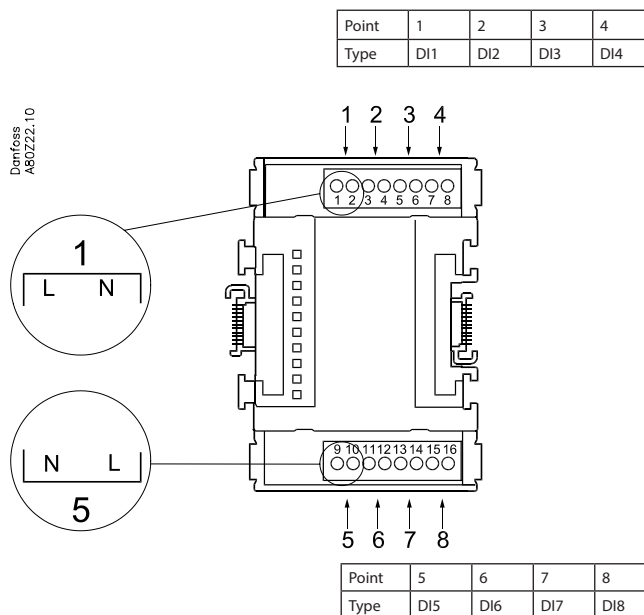

	Signal	Active at
DI	<p>AK-XM 102A: Max. 24 V AK-XM 102B: Max. 230 V</p> <p>Day/ Night</p> <p>Comp. safety 1-6</p> <p>Cond.fan safety</p>	<p><b>Closed</b> (voltage on)</p> <p>/</p> <p><b>Open</b> (voltage off)</p>

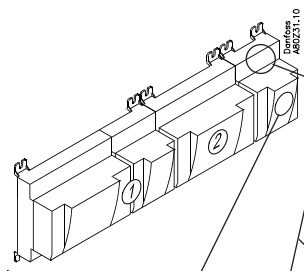

Signal	Module	Point	Terminal	Active at
	3 (2)	1 (DI 1)		
		2 (DI 2)	3 - 4	
		3 (DI 3)	5 - 6	
		4 (DI 4)	7 - 8	
		5 (DI 5)	9 - 10	
		6 (DI 6)	11 - 12	
		7 (DI 7)	13 - 14	
		8 (DI 8)	15 - 16	

Function and terminal number is mentioned in the actual diagram

## Extension module AK-XM 204A / AK-XM 204B

### Function

The module contains 8 relay outputs.

### Supply voltage

The supply voltage to the module comes from the previous module in the row.

### AK-XM 204B only

#### Override of relay

Eight change-over switches at the front make it possible to override the relay's function.

Either to position OFF or ON.

In position Auto the controller carries out the control.

### Light-emitting diodes

There are two rows with LED's. They indicate the following:

Left row:

- Voltage supply to the controller
- Communication active with the bottom PC board (red = error)
- Status of outputs DO1 to DO8

Right row: (AK-XM 204B only):

- Override of relays
- ON = override
- OFF = no override

### Fuses

Behind the upper part there is a fuse for each output.

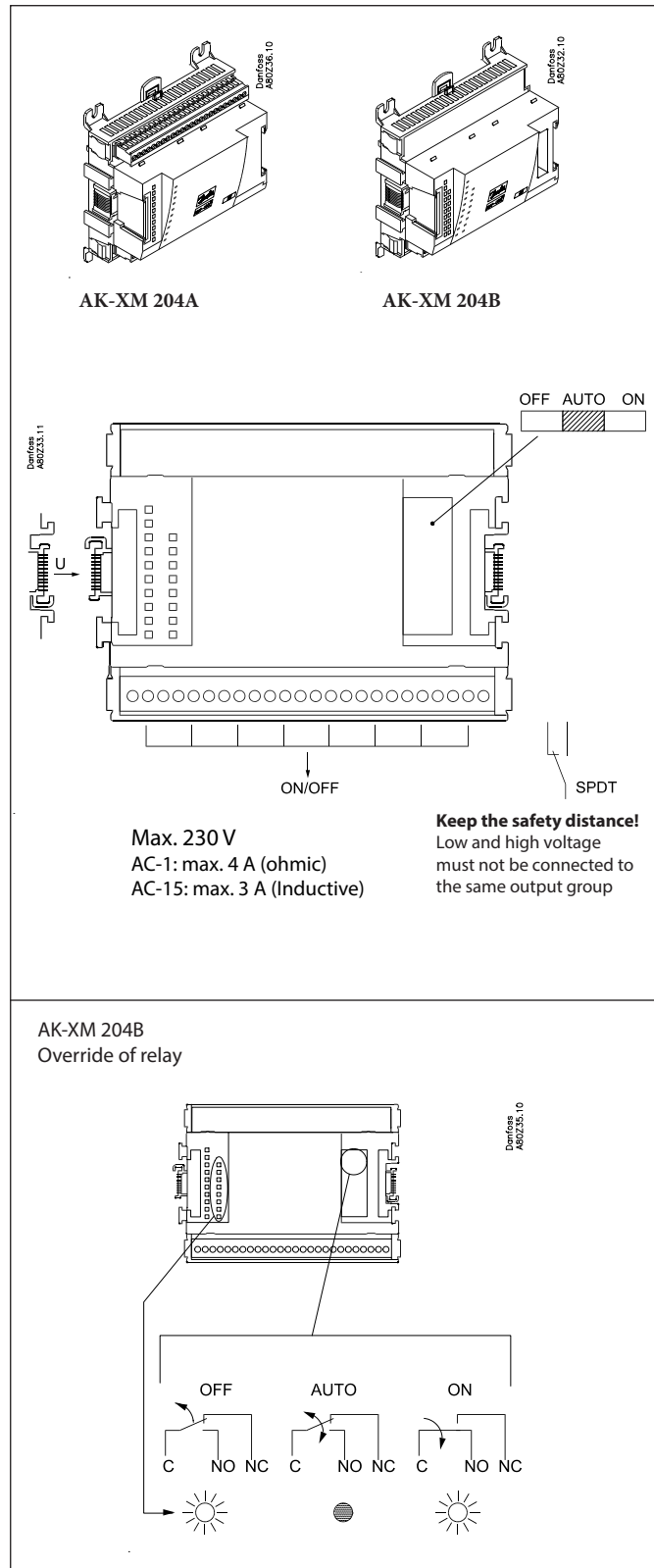



Point

Danfoss  
A80Z34.10

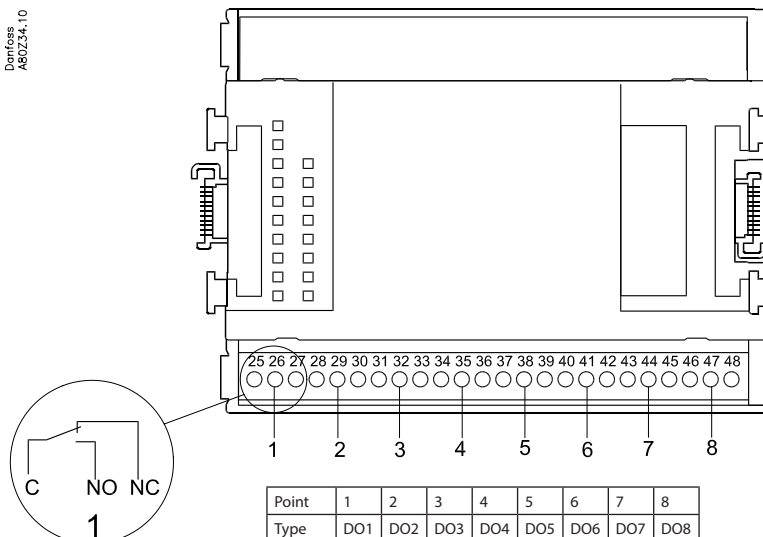

Signal	Active at
	On / Off Fans 1 Alarm

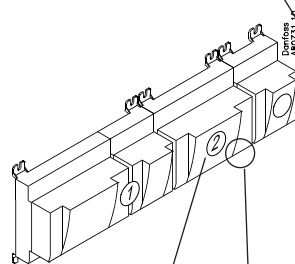

Signal	Module	Point	Terminal	Active at
		1 (DO 1)	25 - 27	
		2 (DO 2)	28 - 30	
		3 (DO 3)	31 - 33	
		4 (DO 4)	34 - 36	
		5 (DO 5)	37 - 39	
		6 (DO 6)	40 - 41 - 42	
		7 (DO 7)	43 - 44 - 45	
		8 (DO 8)	46 - 47 - 48	

Function and terminal number is mentioned in the actual diagram

## Extension module AK-OB 110

### Function

The module contains two analog voltage outputs of 0 – 10 V.

### Supply voltage

The supply voltage to the module comes from the controller module.

### Placing

The module is placed on the PC board in the controller module.

### Point

The two outputs have points 24 and 25. They are shown on the earlier page where the controller is also mentioned.

Max. load

$I < 2.5 \text{ mA}$

$R > 4 \text{ kohm}$

<b>AO</b>	-	→	0-10 V	AO1:	0 - 10 V
	+	→		AO2:	
				Comp.speed	
				Cond.speed	

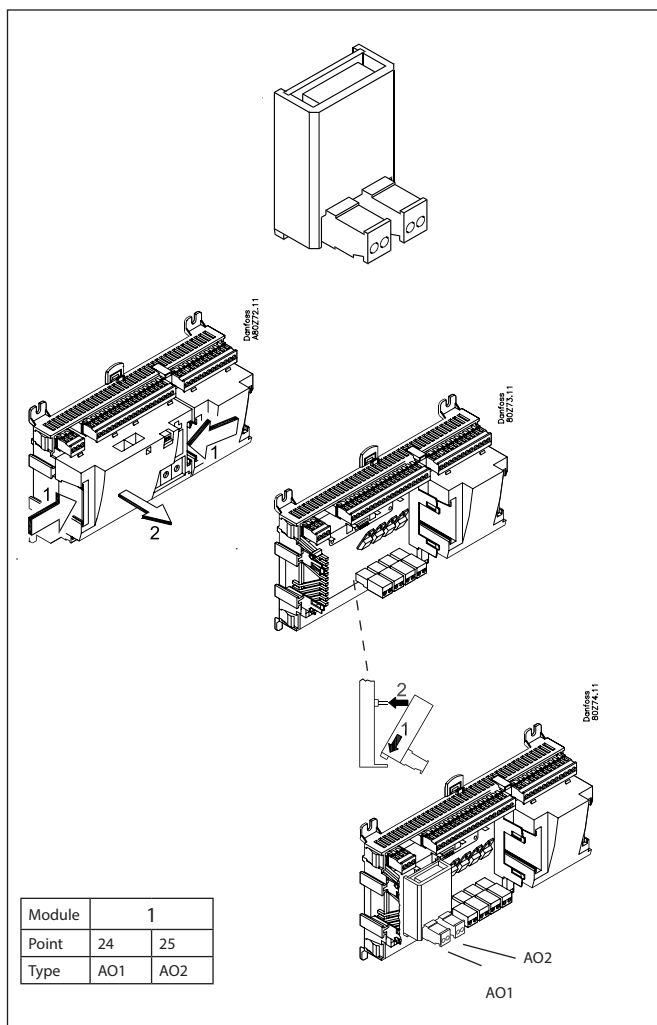

## Extension module AK-OB 101A

### Function

The module is a real time clock module with battery backup.

The module can be used in controllers that are not linked up in a data communication unit together with other controllers. The module is used here if the controller needs battery backup for the following functions

- Clock function
- Fixed times for day/night change-over
- Saving of alarm log in case of power failure
- Saving of temperature log in case of power failure

### Connection

The module is provided with plug connection.

### Placing

The module is placed on the PC board inside the top part.

### Point

No point for a clock module to be defined – just connect it.

### Working life of the battery

The working life of the battery is several years – even if there are frequent power failures.

An alarm is generated when the battery has to be replaced.

After the alarm there are still several months of operating hours left in the battery.

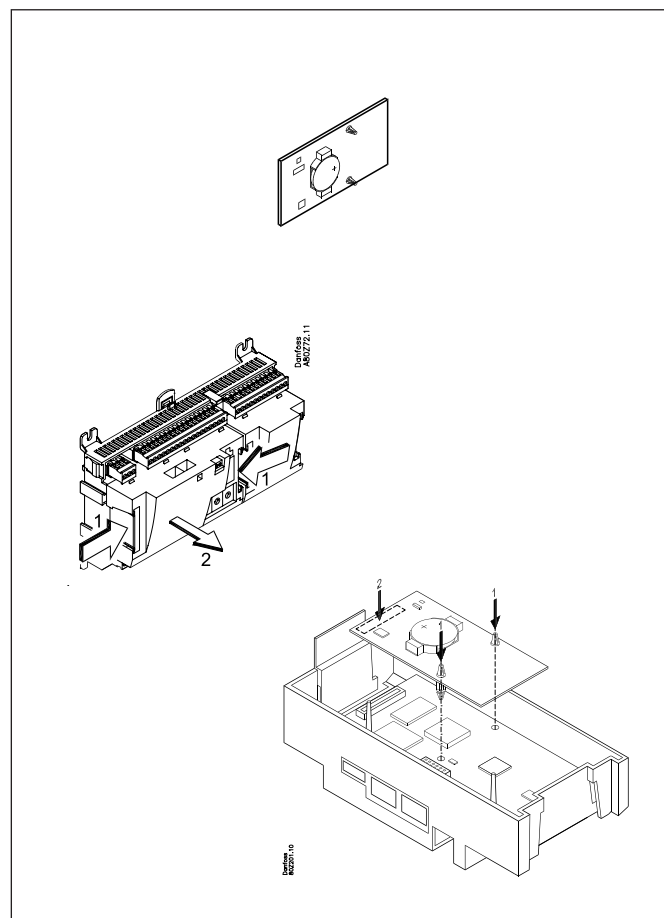

## Extension module EKA 163B / EKA 164B

### Function

Display of important measurements from the controller, e.g. suction pressure or condensing pressure.  
Setting of the individual functions can be performed by using the display with control buttons.

### Connection

The extension module is connected to the controller module via a cable with plug connections. You have to use one cable per module. The cable is supplied in various lengths.

Both types of display (with or without control buttons) can be connected to either display output A, and B.

A = P0 . Suction pressure in °C

B = Pc. Condensing pressure in °C

EKA 166 further includes a number of LEDs to make it possible to follow individual functions.

When the controller starts up, the display will show which output is connected. -- 1 = output A, -- 2 = output B, etc.

### Placing

The extension module can be placed at a distance of up to 15 m from the controller module.

### Point

No point has to be defined for a display module – you simply connect it.

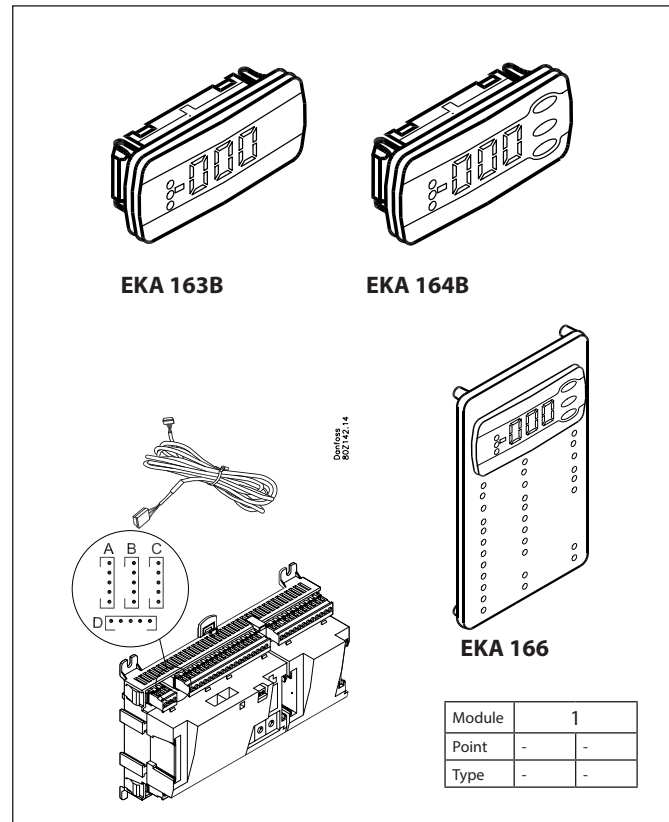

## Graphic display AK-MMI

### Function

Setting and display of values in the controller.

### Connection

The display connects to the controller via a cable with plug connections. Use plug RJ45 to connect to the controller; the same plug is also used for service tool AK-ST 500.

### Supply voltage

24 V a.c. / d.c. 1.5 VA.

### Placing

The display can be placed at a distance of up to 3 m from the controller.

### Point

No point has to be defined for a display – you simply connect it.

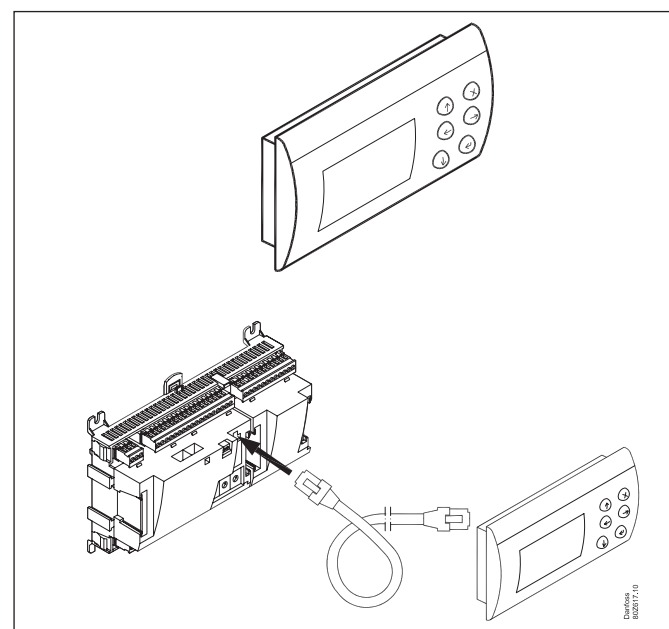

## Power supply module AK-PS 075

### Function

24 V supply for controller.

### Supply voltage

230 V a.c. or 115 V a.c. (from 100 V a.c. to 240 V a.c.)

### Placing

On DIN-rail

### Effect

Type	Output tension	Output current	Power
AK-PS 075	24 V d.c.	0.75 A	18 VA

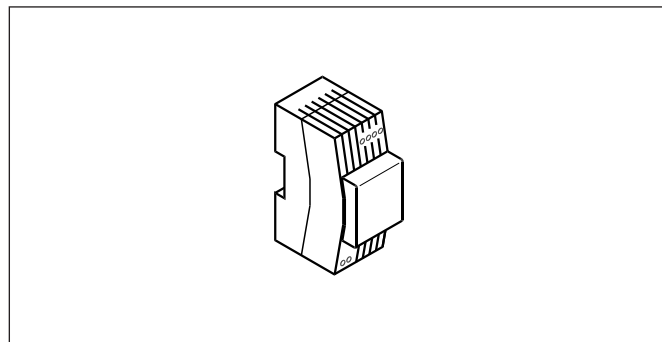

### Dimension

Type	High	Width
AK-PS 075	90 mm	36 mm

### Supply to a controller

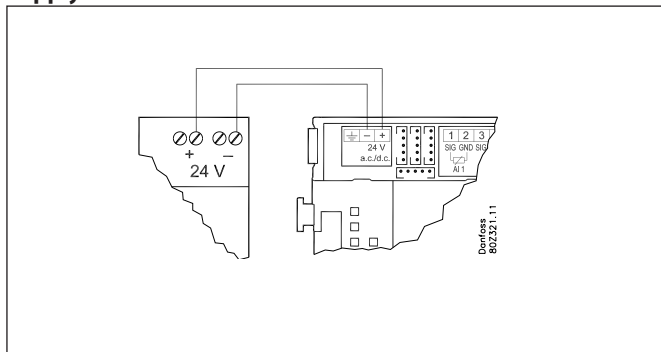

### Connections

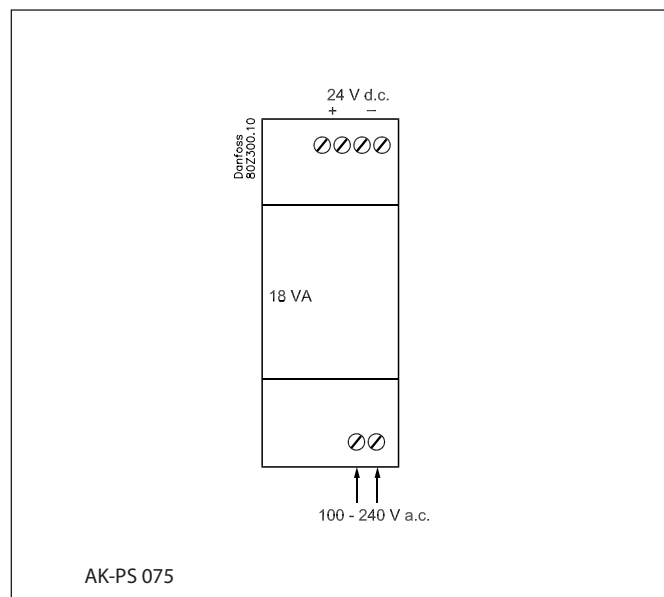

# Select application

## General

### Clock function

Clock function and change-over between summer time and winter time are contained in the controller.  
 The clock is zeroreset when there is power failure.  
 The clock's setting is maintained if the controller is linked up in a network with a gateway, a system manager or a clock module can be mounted in the controller.

### Start/stop of regulation

Regulation can be started and stopped via the software or via an input on the controller module

### Forced control

The software contains a forced control option. If an extension module with relay outputs is used, the module's top part can be with change-over switches – switches that can override the individual relays into either OFF or ON position.

### Data communication

The controller module has terminals for LON data communication. The requirements to the installation are described in a separate document.

## Application

40 examples of application are shown in the following: Select the one that fits your system.

**Wiring should be done as shown, and the controller should be set for this application.**

### Regarding speed regulation

An option board has 2 outputs:  
 No. 1 is dedicated to the compressor  
 No. 2 is dedicated to the condenser fans

If you do not use speed control, disregard the shown 0-10V outputs.

It is only the compressor connection that is shown in all examples, but output 2 can be used for condenser fans at will.

If the speed control needs a start/stop signal, this should be taken from output "Compressor 1" or from "Fan 1".

Number of compressors	Number of condenser fans	Speed regulation on one compressor	
		Yes	No
		Application no.	
2	0	1	21
	2	2	22
	3	3	23
	4	4	24
3	0	5	25
	3	6	26
	4	7	27
	5	8	28
4	0	9	29
	3	10	30
	4	11	31
	5	12	32
5	0	13	33
	4	14	34
	5	15	35
	6	16	36
6	0	17	37
	4	18	38
	5	19	39
	6	20	40



**Application 1 and 21** (for 21 leave out the VSD connection on the option board)

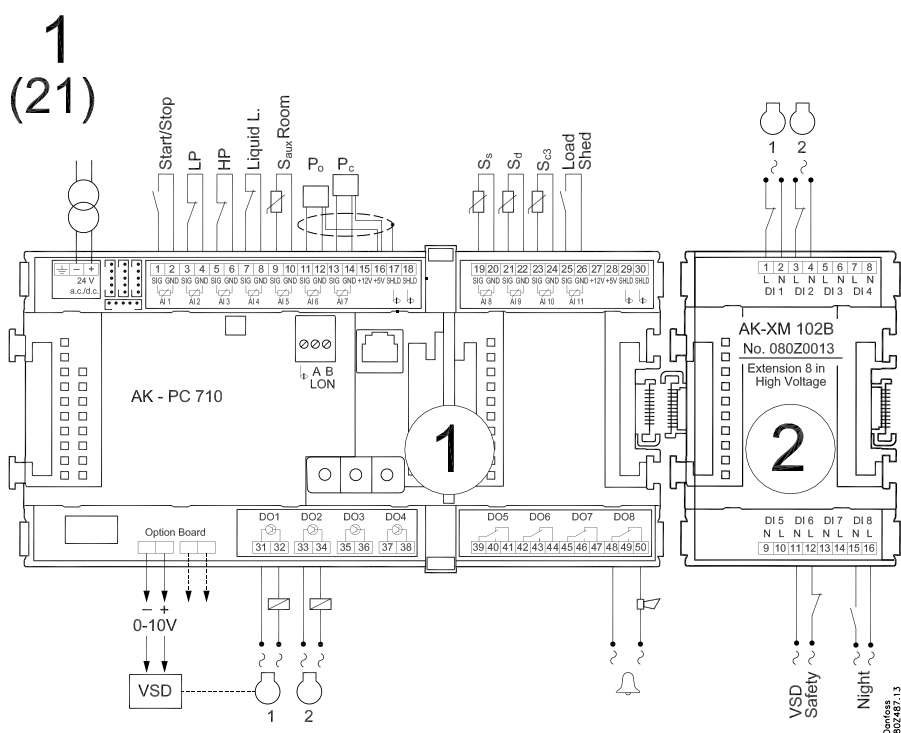

**Application 2 and 22** (for 22 leave out the VSD connection on the option board)

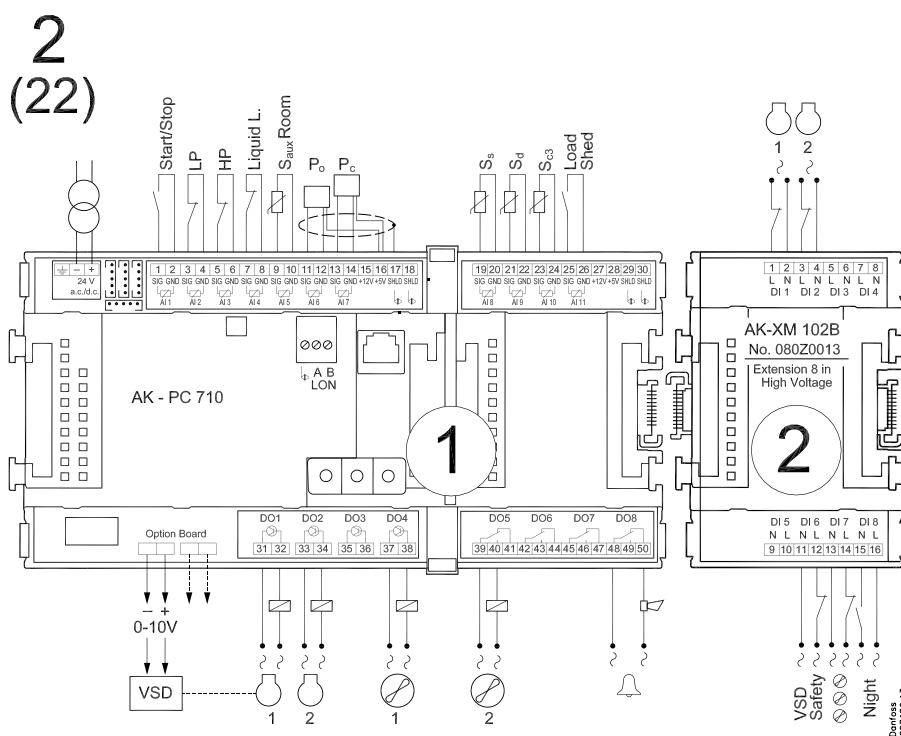

**Application 3 and 23** (for 23 leave out the VSD connection on the option board)

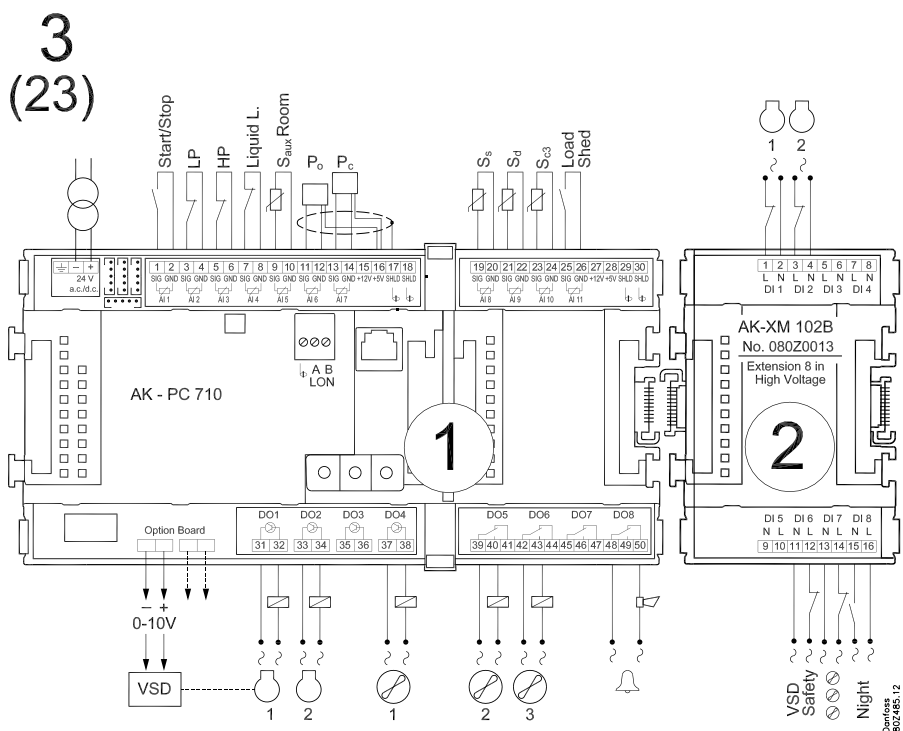

**1**

**Application 4 and 24** (for 24 leave out the VSD connection on the option board)

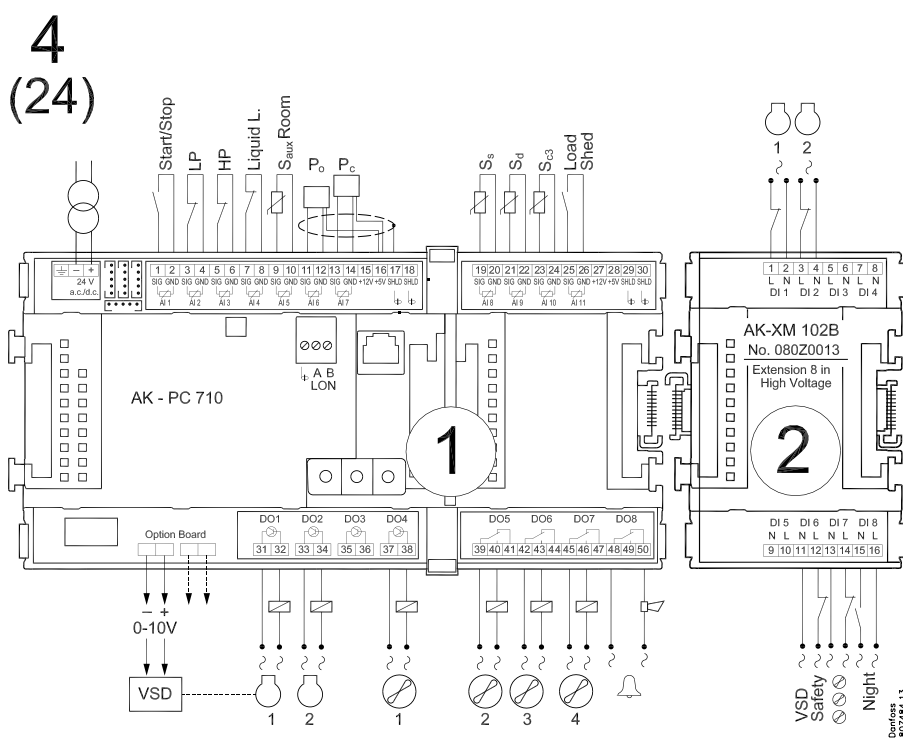

**Application 5 and 25** (for 25 leave out the VSD connection on the option board)

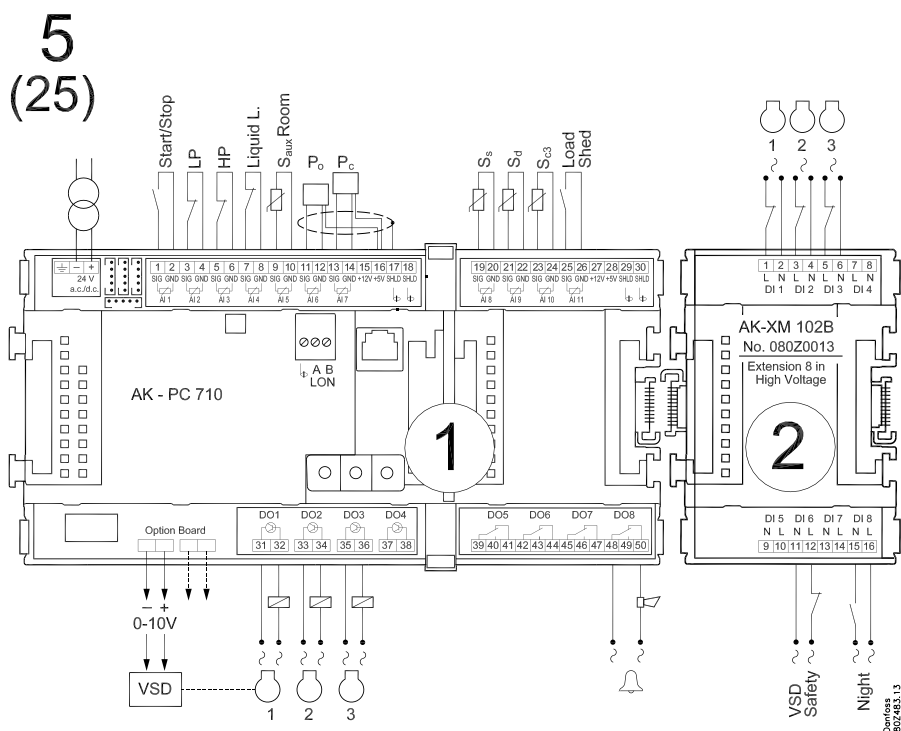

**Application 6 and 26** (for 26 leave out the VSD connection on the option board)

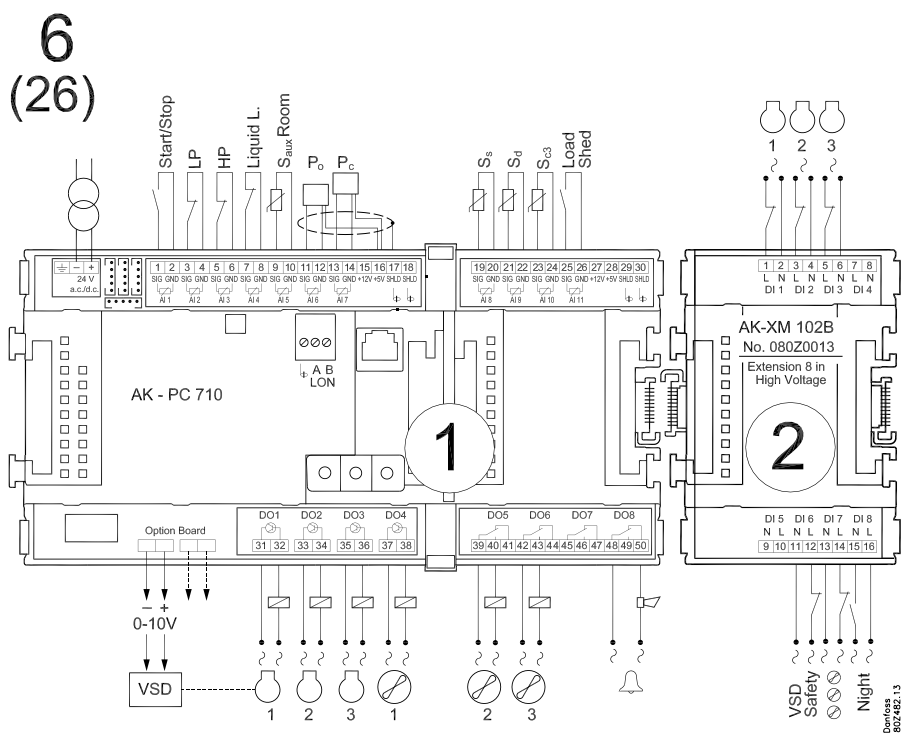

**Application 7 and 27** (for 27 leave out the VSD connection on the option board)

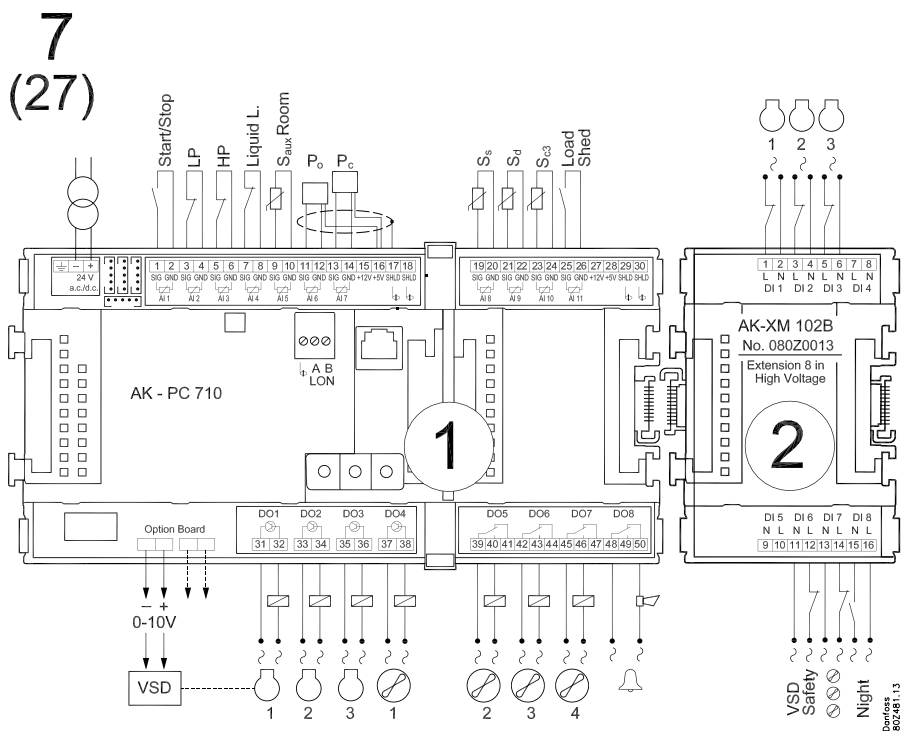

**Application 8 and 28** (for 28 leave out the VSD connection on the option board)

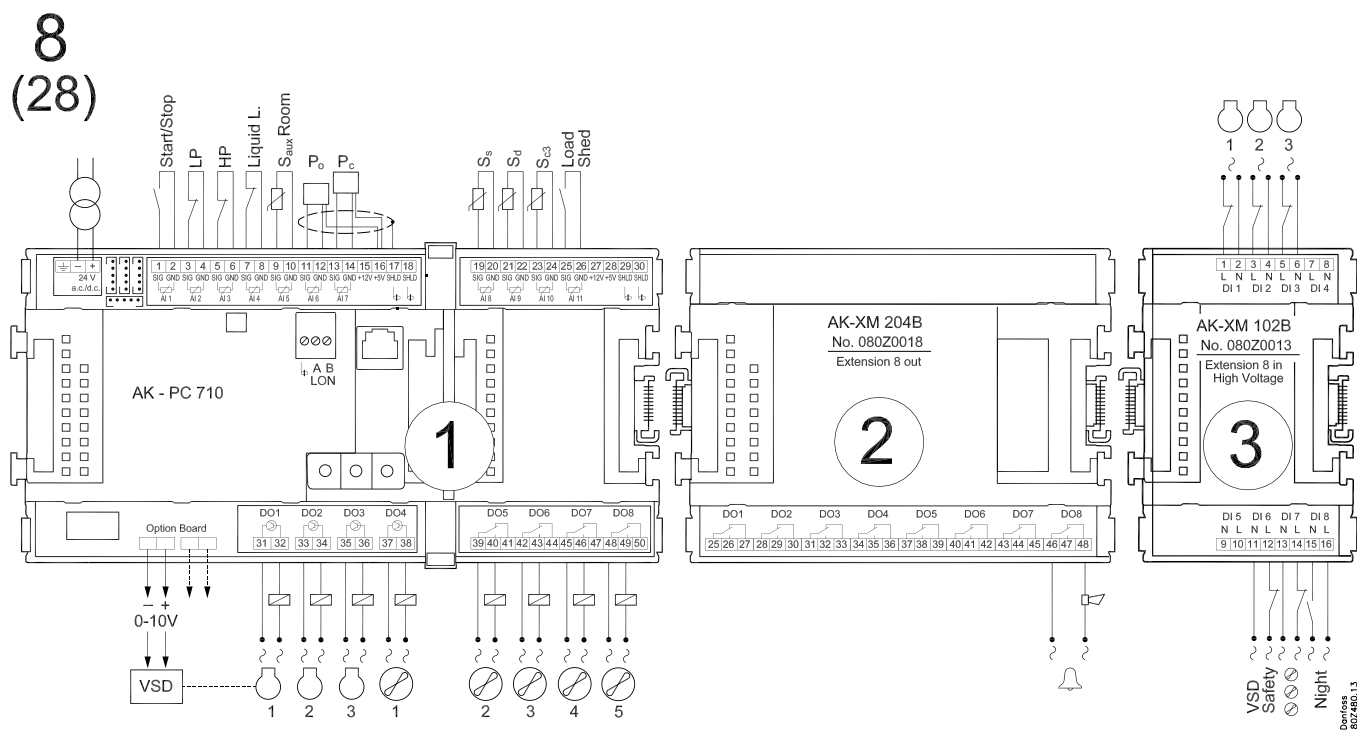

**Application 9 and 29** (for 29 leave out the VSD connection on the option board)

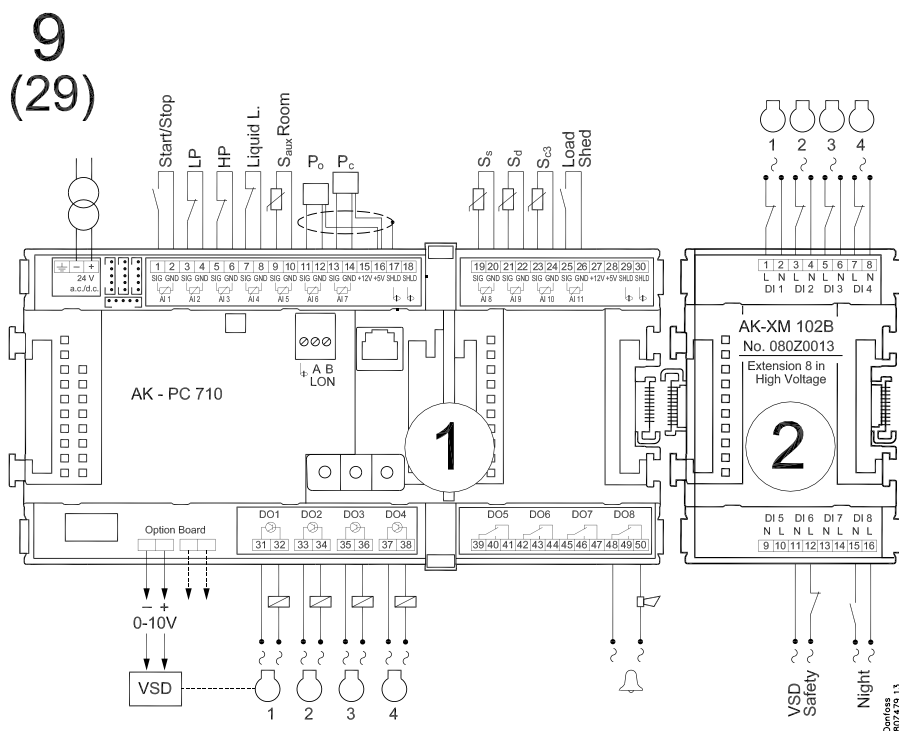

**Application 10 and 30** (for 30 leave out the VSD connection on the option board)

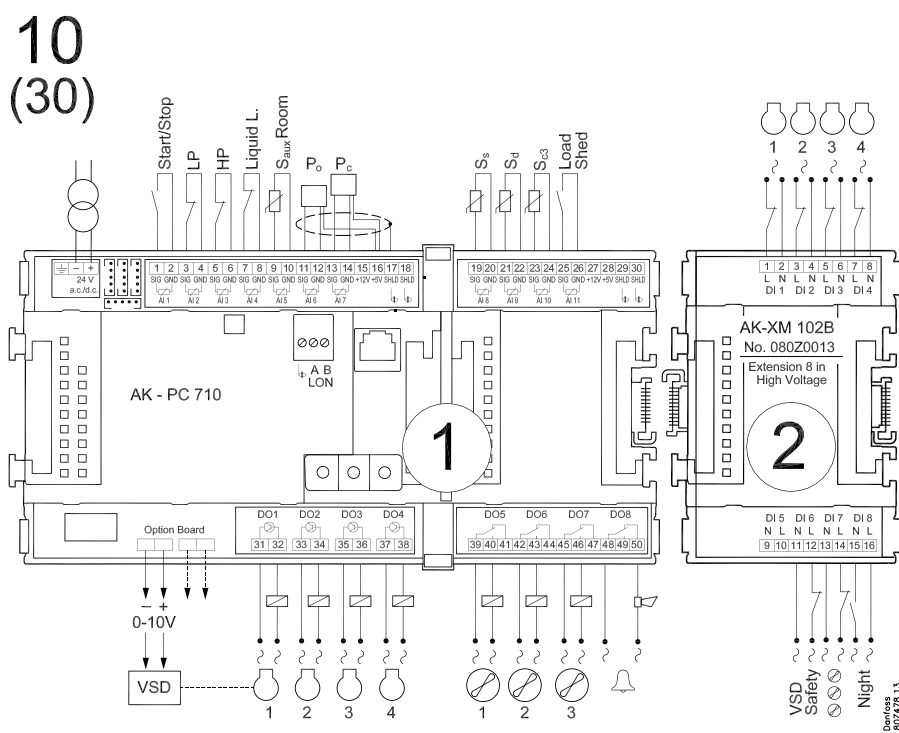

**Application 11 and 31** (for 31 leave out the VSD connection on the option board)

**11**  
**(31)**

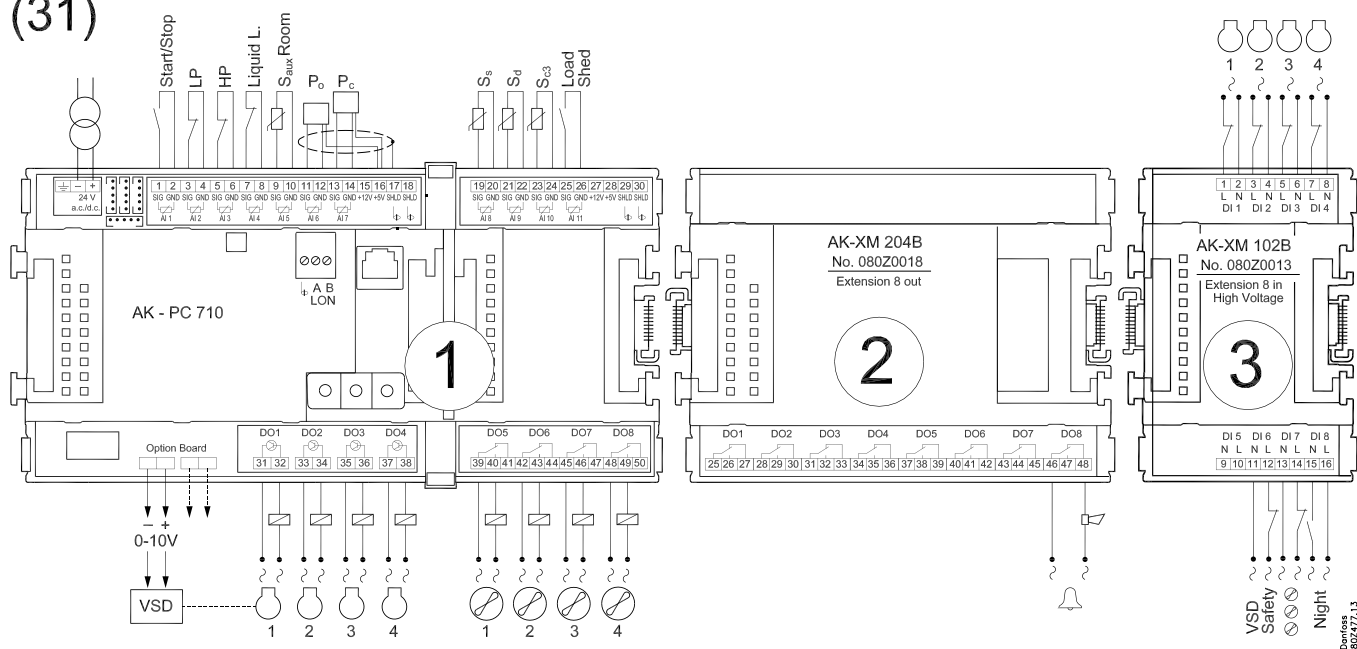

**Application 12 and 32** (for 32 leave out the VSD connection on the option board)

**12**  
**(32)**

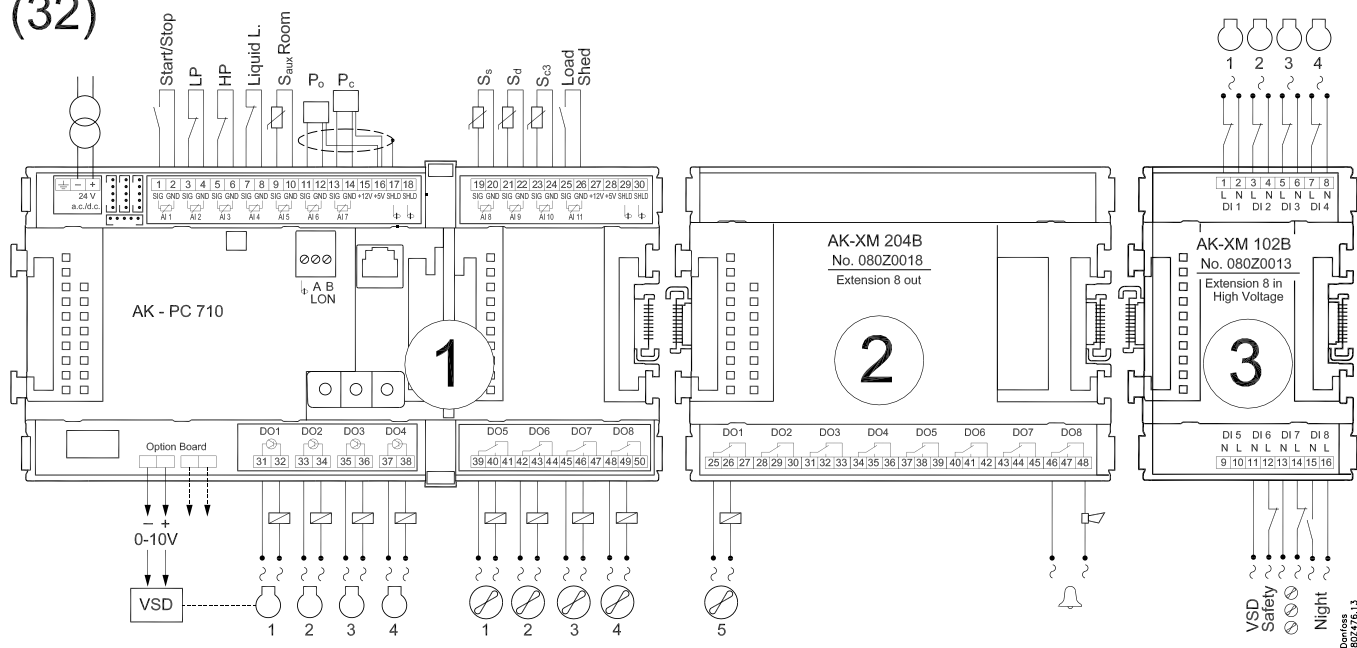



**Application 13 and 33** (for 33 leave out the VSD connection on the option board)

13  
(33)

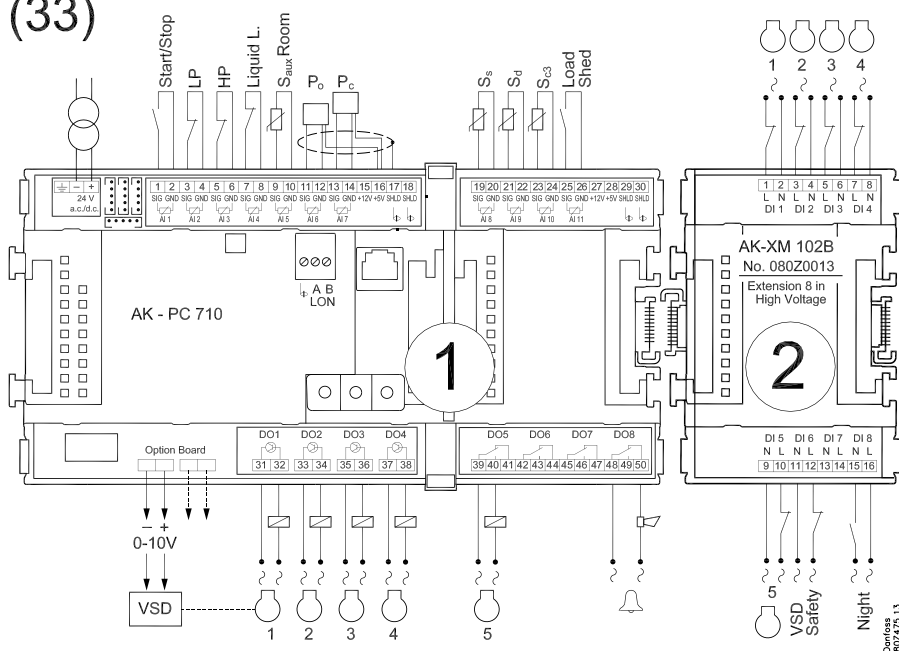

**Application 14 and 34** (for 34 leave out the VSD connection on the option board)

14  
(34)

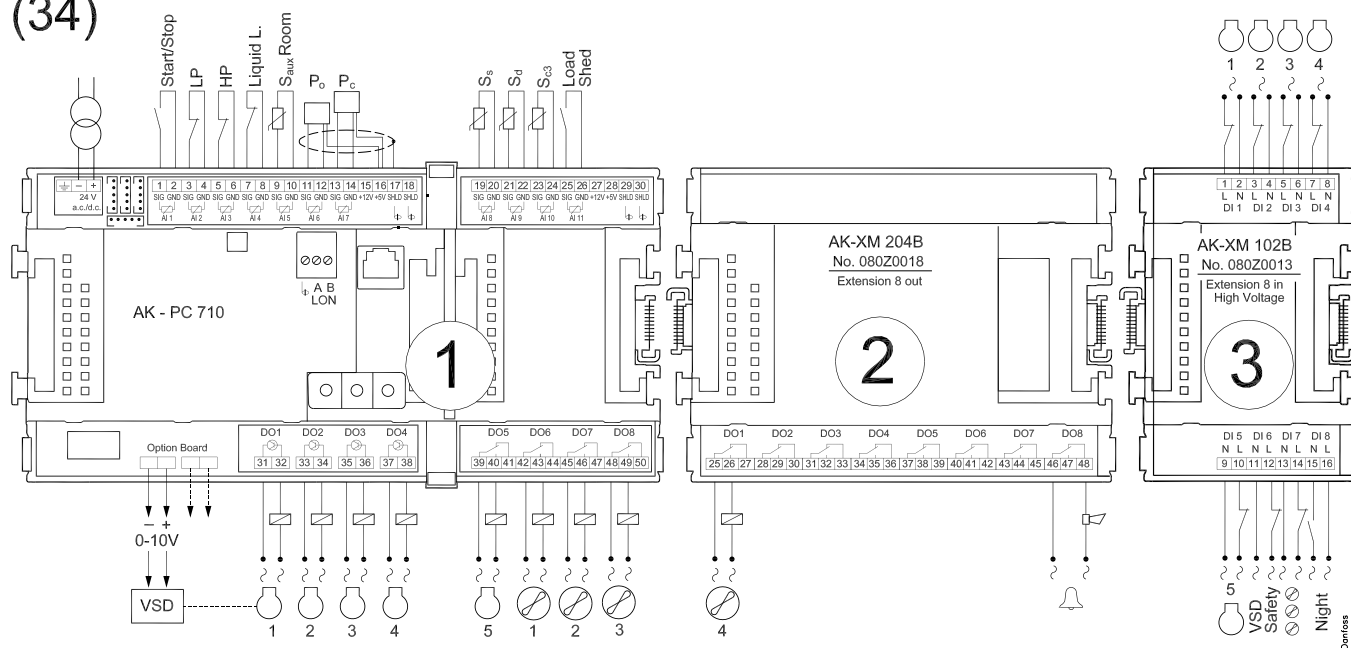

**Application 15 and 35** (for 35 leave out the VSD connection on the option board)

15  
(35)

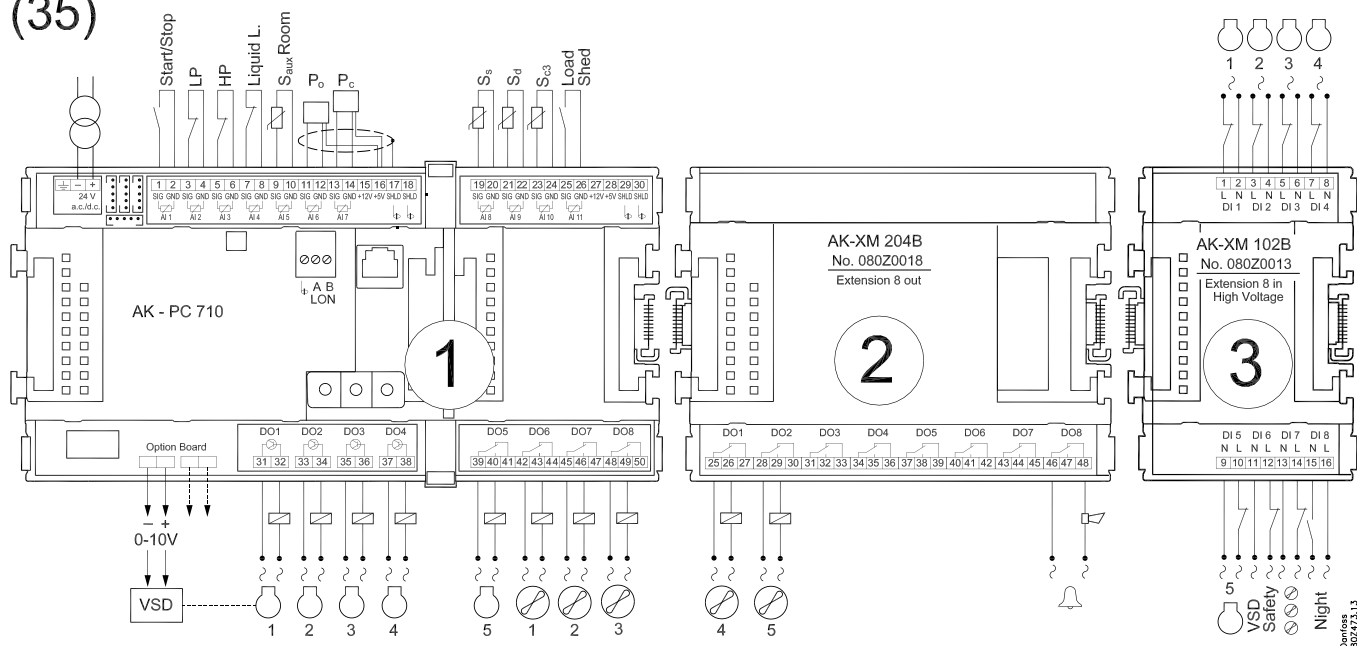

**Application 16 and 36** (for 36 leave out the VSD connection on the option board)

16  
(36)

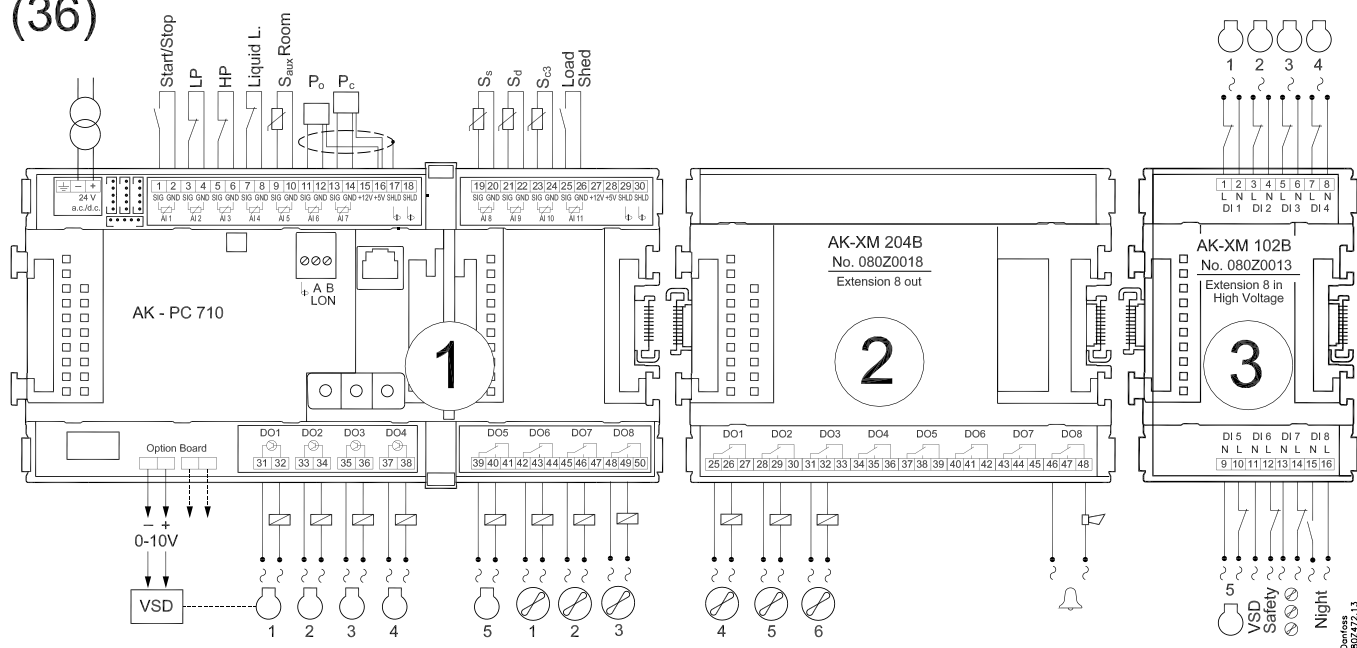

**Application 17 and 37** (for 37 leave out the VSD connection on the option board)

17  
(37)

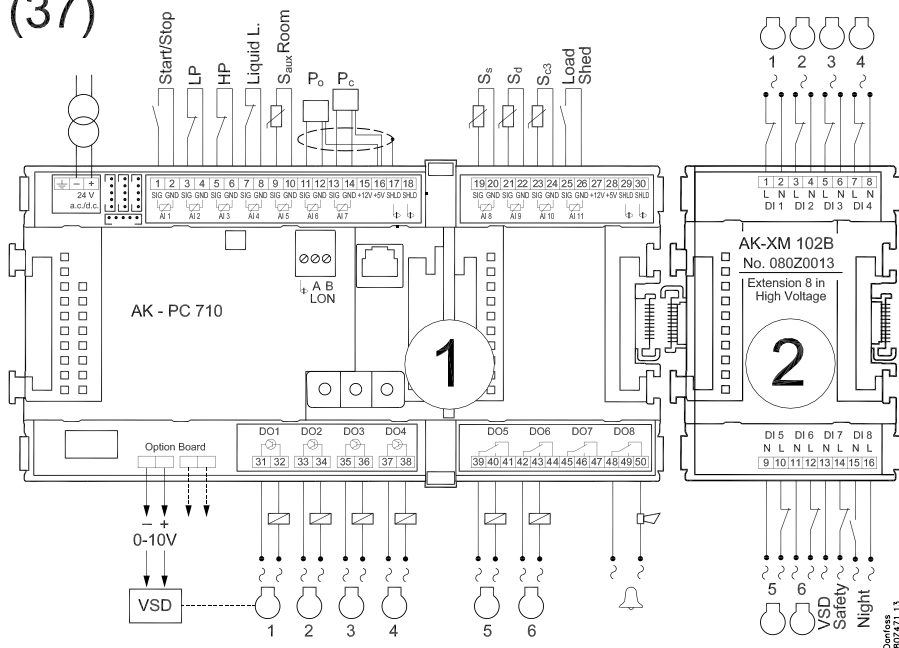

**Application 18 and 38** (for 38 leave out the VSD connection on the option board)

18  
(38)

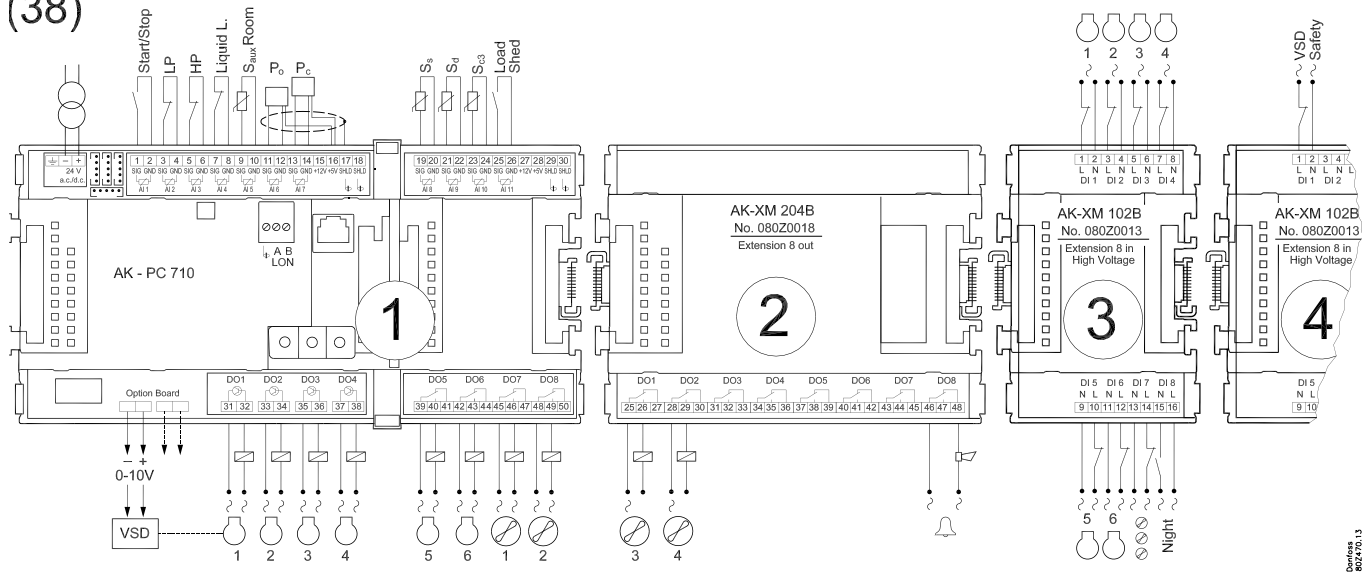

**Application 19 and 39** (for 39 leave out the VSD connection on the option board)

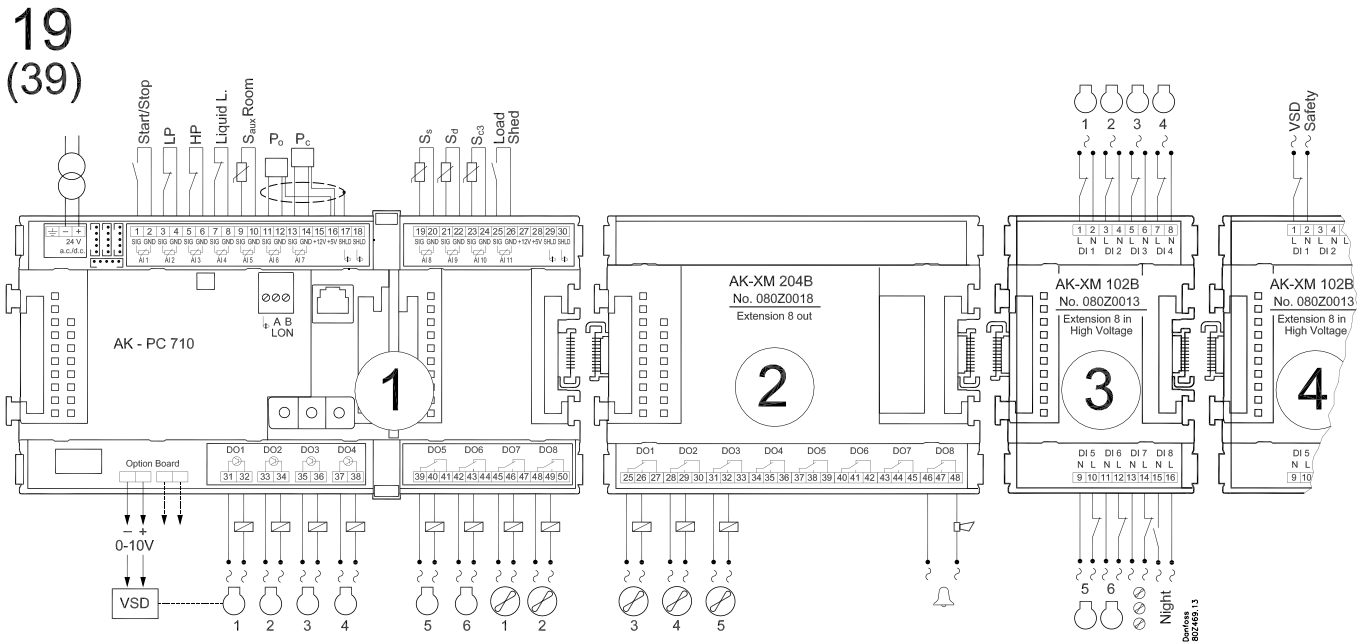

**Application 20 and 40** (for 40 leave out the VSD connection on the option board)

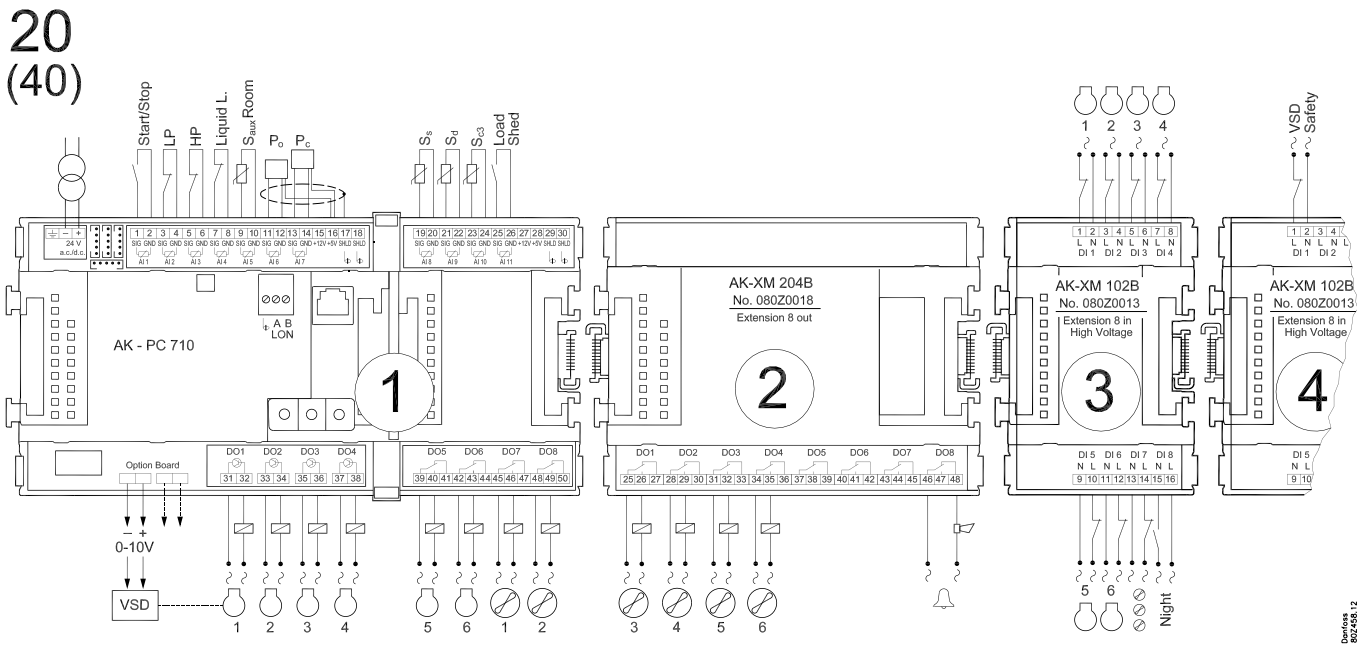

# Ordering

## 1. Controller

Type	Function	Language	Code no.
AK-PC 710	Controller for capacity control of up to 6 compressors and up to 6 condenser fans	English, German, French, Dutch, Italian, Spanish	<b>080Z0106</b>

## 2. Extension modules and survey for inputs and outputs

Type	Analog inputs	On/Off outputs		On/off supply voltage (DI signal)		Analog outputs	Module with switches	Code no.
	For sensors, pressure transmitters etc.	Relay (SPDT)	Solid state	Low voltage (max. 80 V)	High voltage (max. 260 V)	0-10 V d.c.	For override of relay outputs	With screw terminals
Controller	11	4	4	-	-	-	-	-
Extension modules								
AK-XM 102A				8				<b>080Z0008</b>
AK-XM 102B					8			<b>080Z0013</b>
AK-XM 204A		8						<b>080Z0011</b>
AK-XM 204B		8					x	<b>080Z0018</b>
AK-OB 110						2		<b>080Z0251</b>

## 3. AK operation and accessories

Type	Function	Application	Code no.
<b>Operation</b>			
AK-ST 500	Software for operation of AK controllers	AK-operation	<b>080Z0161</b>
-	Cable between PC and AK controller	AK - Com port	<b>080Z0262</b>
-	Cable between zero modem cable and AK controller / Cable between PDA cable and AK controller	AK - RS 232	<b>080Z0261</b>
-	Cable between PC and AK controller	AK - USB	<b>080Z0264</b>
<b>Accessories</b>	<b>Power supply module 230 V / 115 V to 24 V</b>		
AK-PS 075	18 VA	Supply for controller	<b>080Z0053</b>
<b>Accessories</b>	<b>External display that can be connected to the controller module. For showing, say, the suction pressure</b>		
EKA 163B	Display		<b>084B8574</b>
EKA 164B	Display with operation buttons		<b>084B8575</b>
EKA 166	Display with operation buttons and LED's for inputs and outputs		<b>084B8578</b>
AK-MMI	Graphic display with operation		<b>080G0311</b>
-	Cable between EKA display and controller	Length = 2 m	<b>084B7298</b>
-		Length = 6 m	<b>084B7299</b>
-	Cable between graphic display and controller	Length = 0.8 m	<b>080G0074</b>
-		Length = 1.5 m	<b>080G0075</b>
-		Length = 3 m	<b>080G0076</b>
<b>Accessories</b>	<b>Real time clock for use in controllers that require a clock function, but are not wired with data communication.</b>		
AK-OB 101A	Real time clock with battery backup.	To be mounted in an AK controller	<b>080Z0252</b>



---

## 3. Mounting and wiring

---

This section describes how the controller:

- Is fitted
- Is connected

# Mounting

## Mounting of analog output module

### 1. Lift the top part off the basic module

The basic module must not be connected to voltage.

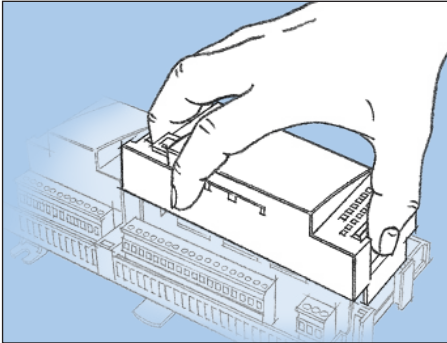

Press in the plate on the left-hand side of the light-emitting diodes and the plate on the right-hand side for the red address changers.

Lift the top part off the basic module.

### 2. Mount the extension module in the basic module

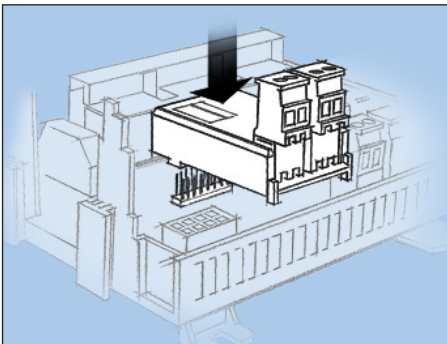

### 3. Put the top part back on the basic module

The analog extension module will supply a signal to the variable frequency drive.

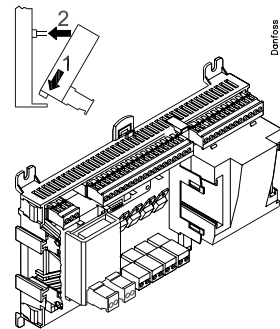

Danfoss  
862744.1



## Mounting of extension module on the basic module

### 1. Move the protective cap

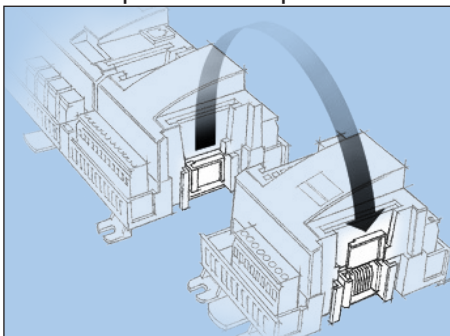

Remove the protective cap from the connection plug on the right-hand side of the basic module.  
Place the cap on the connection plug to the right of the extension module that is to be mounted on the extreme right-hand side of the AK assembly.

### 2. Assemble the extension module and the basic module

The basic module must not be connected to voltage.

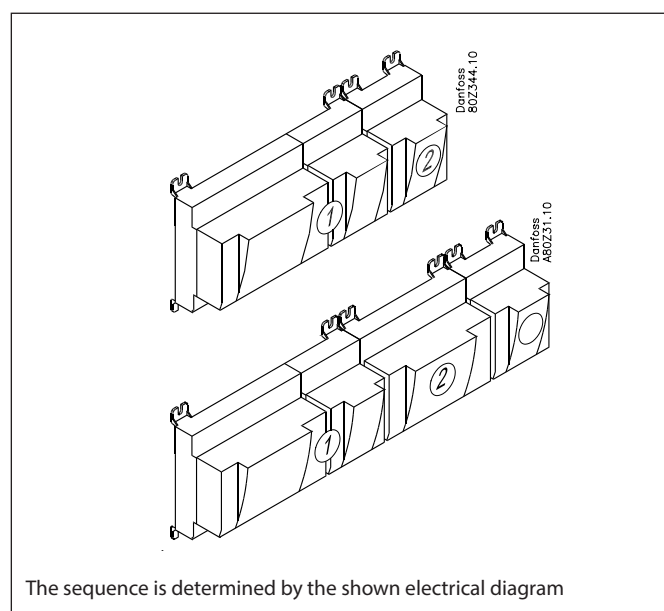
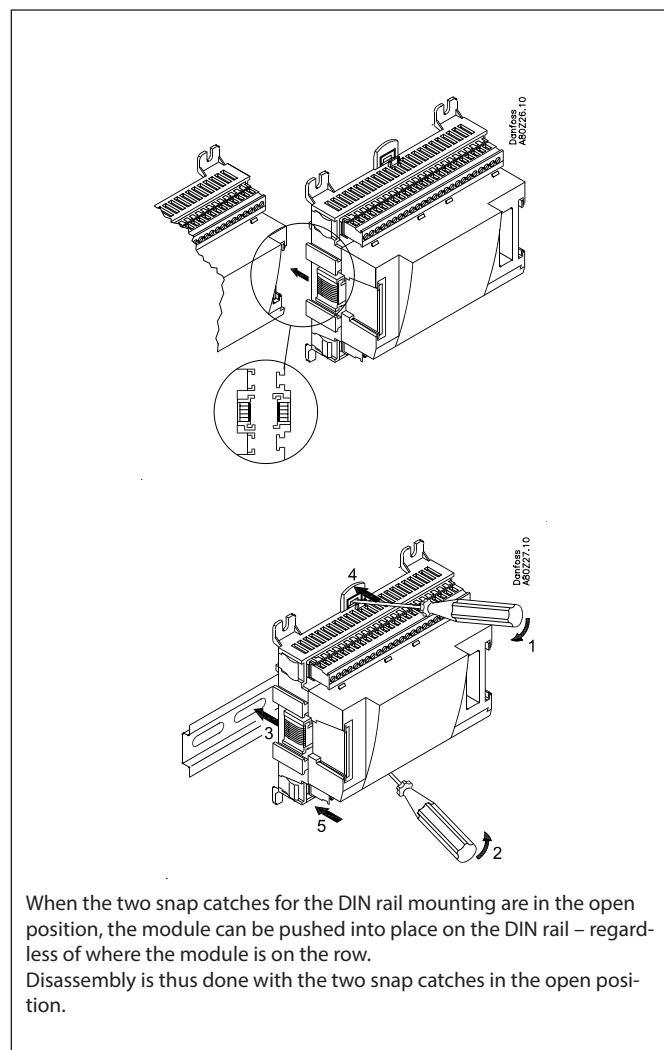
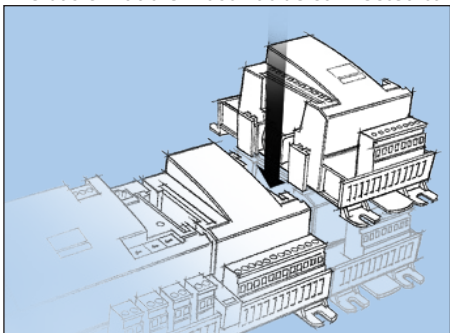

# Wiring

Decide during planning which function is to be connected and where this will be.

## 1. Connect inputs and outputs

See the earlier selected electrical diagram:

## 2. Connect LON communication network

The installation of the data communication must comply with the requirements set out in document RC8AC.

## 3. Connect supply voltage

Is 24 V, and the supply must not be used by other controllers or devices. The terminals must not be earthed.

## 4. Follow light-emitting diodes

When the supply voltage is connected the controller will go through an internal check. The controller will be ready in just under one minute when the light-emitting diode "Status" starts flashing slowly.

## 5. When there is a network

Set the address and activate the Service Pin.

## 6. The controller is now ready to be configured.

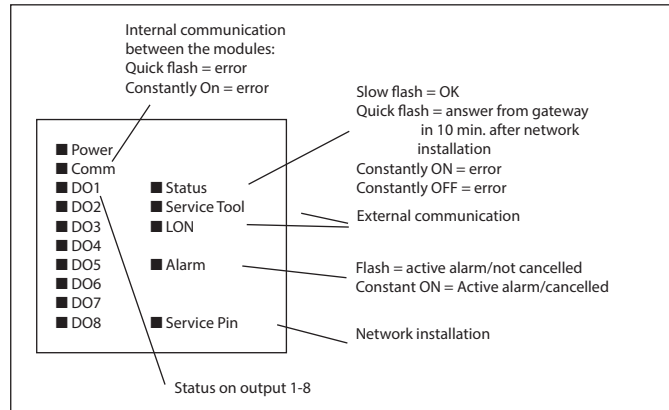

### Example

16  
(36)

The screen on the pressure transmitter cables must only be connected at the end of the controller.

**Warning**  
 Keep signal cables separate from cables with high voltage.

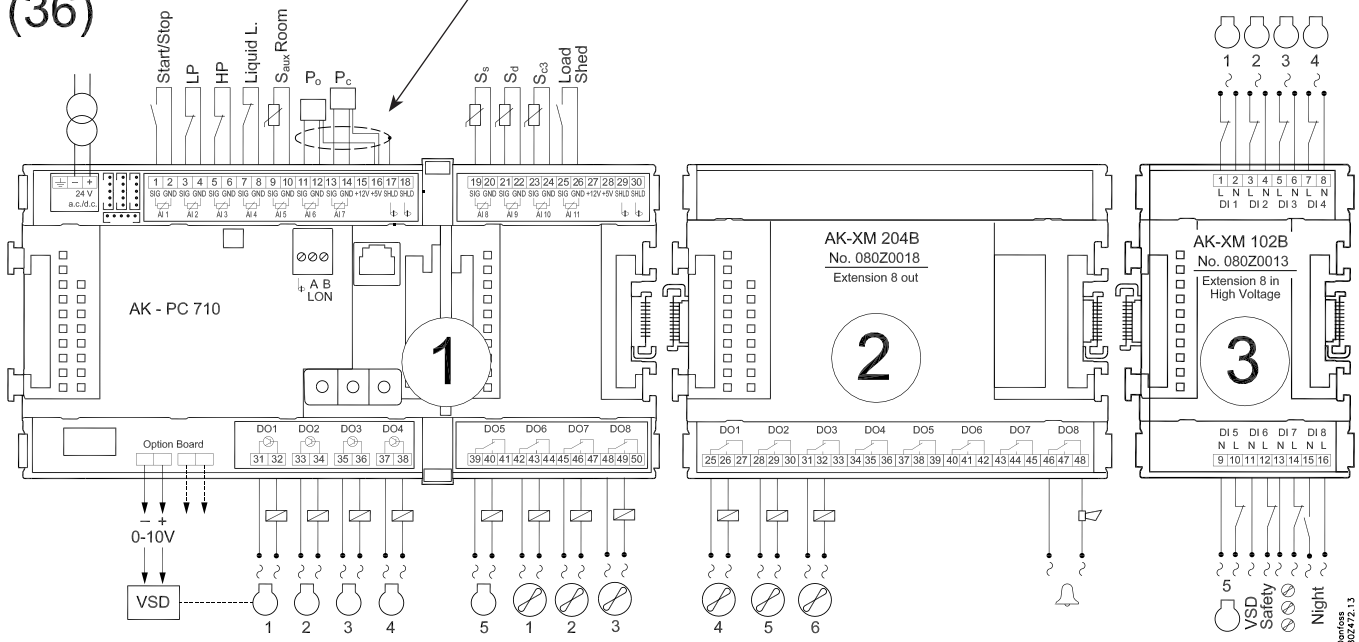

---

## 4. Configuration and operation

---

This section describes how the controller:

- Is configured
- Is operated

We have decided to work on the basis of application no. 16, i.e. compressor control with 5 compressors and condenser control with 6 fans.

The example is shown overleaf.

## Refrigerating plant example

We have decided to describe the setup by means of an example comprising a compressor group and a condenser. The example is the same as the one given in the "Application no. 16", i.e. the controller is an AK-PC 710 + 3 extension modules.

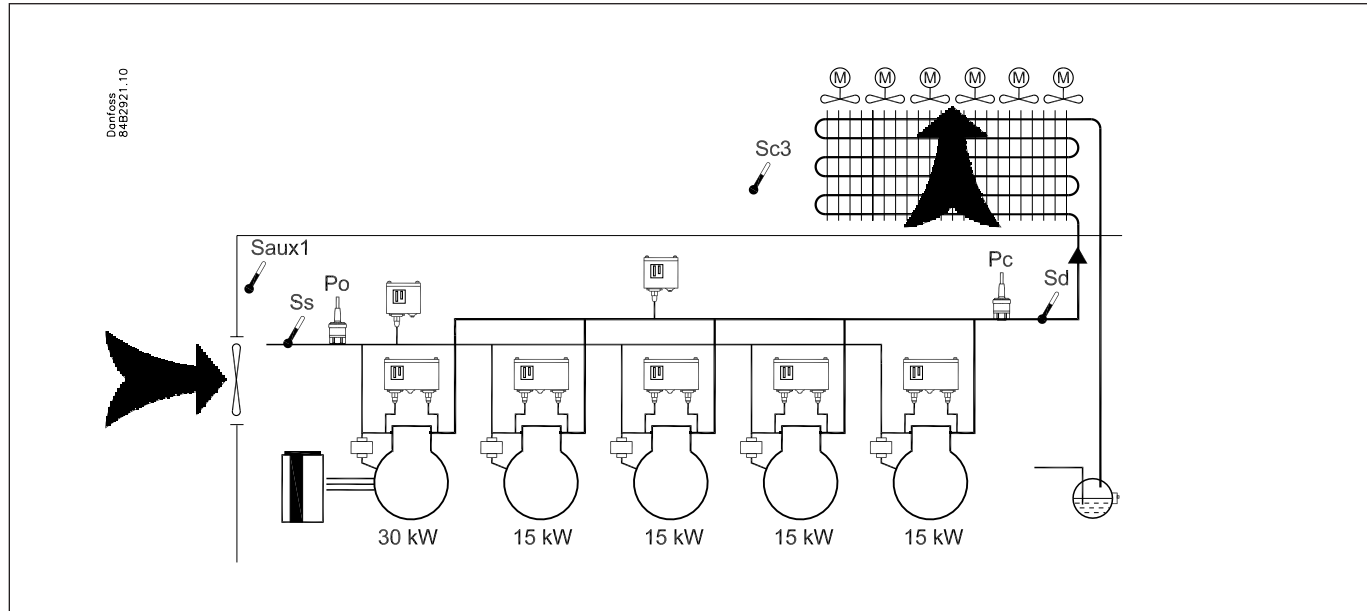

### Compressor pack:

- Refrigerant R134a
- 1 only speed-regulated compressor (30 kW, 30-60 Hz)
- 4 only compressors (15 kW) with working-hour equalisation
- Safety monitoring of each compressor
- Common high-pressure monitoring
- Common low-pressure monitoring
- Po setting  $-15^{\circ}\text{C}$ , night displacement 5 K

### Condenser:

- 6 fans, step regulation
- Pc regulates based on outdoor temperature Sc3

### Receiver:

- Monitoring of liquid level in receiver

### Plant room

- Monitoring of temperature in plant room

### Safety functions:

- Monitoring of Po, Pc, Sd and superheat on suction line
- Po max =  $-5^{\circ}\text{C}$ , Po min =  $-35^{\circ}\text{C}$
- Pc max =  $50^{\circ}\text{C}$
- Sd max =  $120^{\circ}\text{C}$
- SH min =  $5^{\circ}\text{C}$ , SH max =  $35^{\circ}\text{C}$

### Other:

- Alarm output used
- External main switch used
- Monitoring of frequency converter (VSD)

### For the example shown we use the following modules:

- AK-PC 710 basic module
- AK-XM 204B relay module
- AK-XM 102B digital input module
- AK-OB 110 analog output module

### NB!

The capacity of the compressor with speed adjustment should be greater than that of the other compressors. This ensures that there are no "gaps" in the cut in capacity. See chapter 5, Adjustment functions.

There is also an internal main switch as a setting. Both must be "ON" before any adjustment is made.

The used modules is selected in the Design phase.

# Configuration via service tool

## AK-ST 500

### Connect PC

PC with the program "Service Tool" is connected to the controller.

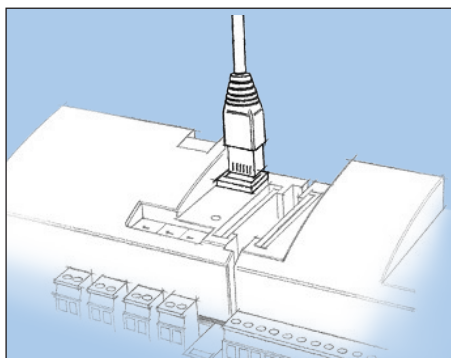

The controller must be switched on first and the LED "Status" must flash before the Service Tool programme is started.

### Start Service Tool programme

#### Login with user name SUPV



Select the name **SUPV** and key in the access code.

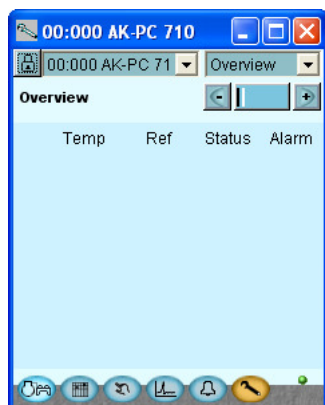

For connecting and operating the "AK service tool" software, please see the manual for the software.

The first time the Service Tool is connected to a new version of a controller the start-up of the Service Tool will take longer than usual while information is retrieved from the controller. Time can be followed on the bar at the bottom of the display.

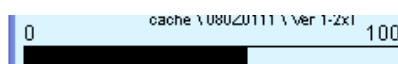

When the controller is supplied the SUPV access code is 123. When you are logged into the controller an overview of it will always appear.

In this case the overview is empty. This is because the controller has not yet been set up. The red alarm bell at the bottom right tells you that there is an active alarm in the controller. In our case the alarm is due to the fact that the time in the controller has not yet been set.

## Authorization

### 1. Go to Configuration menu

Press the orange setup button with the spanner at the bottom of the display.



### 2. Select Authorization

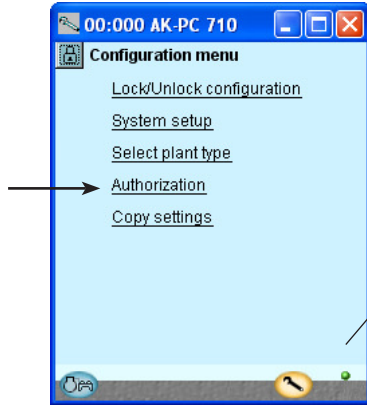

When the controller is supplied it has been set with standard authorization for different user interfaces. This setting should be changed and adapted to the plant. The changes can be made now or later.

You will use this button again and again whenever you want to get to this display. On the left-hand side are all the functions not shown yet. There will be more here the further into the setup we go.

Press the line **Authorization** to get to the user setup display.

### 3. Change setting for the user 'SUPV'

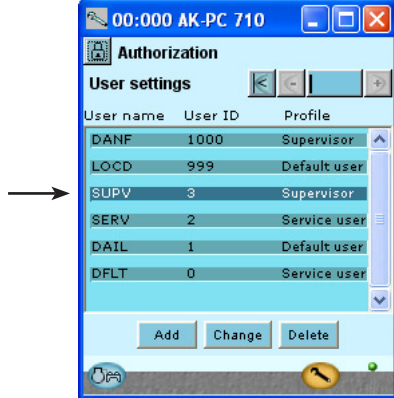

Mark the line with the user name **SUPV**. Press the button **Change**

### 4. Select username and access code



This is where you can select the supervisor for the specific system and a corresponding access code for this person.

In earlier versions of the service tool AK-ST 500 it was possible to select the language in this menu.

An updated version of the service tool will be released in the spring of 2009. If the controller is operated with the new version, language selection will happen automatically in connection with the configuration of the service tool.

The controller will utilize the same language that is selected in the service tool but only if the controller contains this language. If the language is not contained in the controller, the settings and readings will be shown in English.

### 5. Carry out a new login with the user name and the new access code

To activate the new settings you must carry out a new login to the controller with the new user name and the relevant access code. You will access the login display by pressing the padlock at the top left corner of the display.



## Unlock the configuration of the controllers

1. Go to Configuration menu



2. Select Lock/Unlock configuration

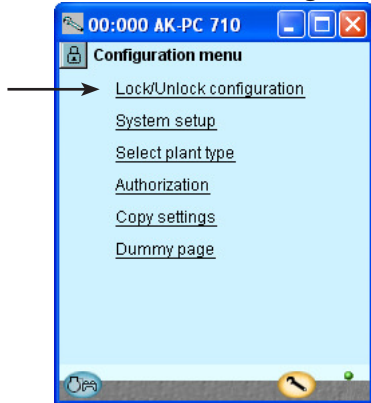

3. Select Configuration lock

Press the blue field with the text **Locked**

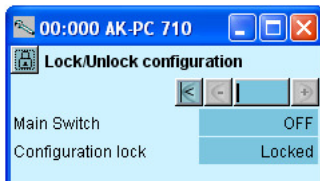

4. Select Unlocked

Select **Unlocked** and press **OK**.



The controller can only be configured when it is unlocked.

The values can be changed when it is locked, but only for those settings that do not affect the configuration.

## System setup

1. Go to Configuration menu



2. Select System setup



3. Set system settings

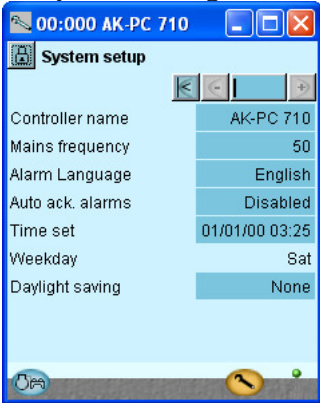

All system settings can be changed by pressing in the blue field with the setting and then indicating the value of the required setting.

In the first field you enter a name for what the controller will be controlling.

When the time is set the PC's time can be transferred to the controller. When the controller is connected to a network, date and time will automatically be set by the system unit in the network. This also applies to change-over Daylight saving.

If the controller is installed in a network, "automatic acknowledgement of alarms" should be set to "disable" - Hereby the alarm processing and acknowledgement is transferred to the system unit. If the controller is installed without a network, "automatic acknowledgement of alarms" should be set to "enable" - Hereby the controller acknowledges the alarms itself.



## Set plant type

1. Go to Configuration menu

2. Select plant type

Press the line **Select plant type**.

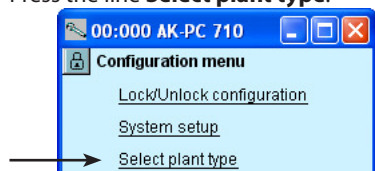

3. Set plant type

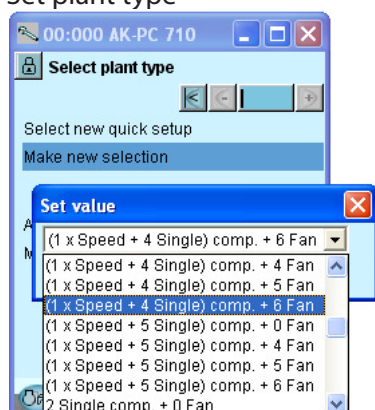

This setting refers to applications. See page 22.

After configuration of this function, the controller will shut down and restart. After the restart, a large number of settings will have been made. These include the connection points. Continue with the settings and check the values. If you change some of the settings, the new values will.

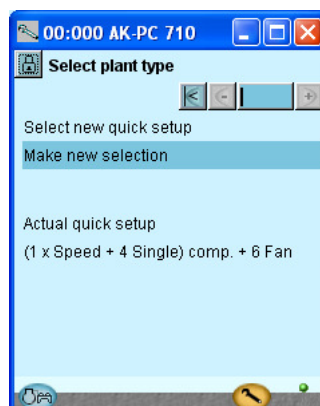

## Set control of compressors

### 1. Go to Configuration menu

### 2. Select Suction group

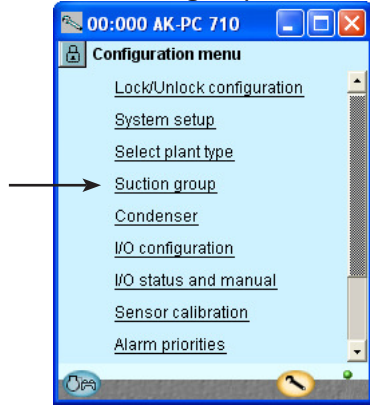

The configuration menu in the Service Tool has changed now. It shows the possible settings for the selected plant type.

### 3. Set values for the reference

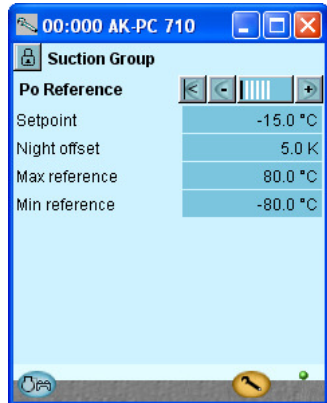

In our example we select the settings:  
 - Suction set point = -15°C  
 - Night offset value = 5 K.  
 The settings are shown here in the display.

Press the + -button to go on to the next page

There are several pages, one after the other.  
 The black bar in this field tells you which of the pages is currently displayed.  
 Move between the pages using the + and - buttons.

### 4. Set values for capacity control

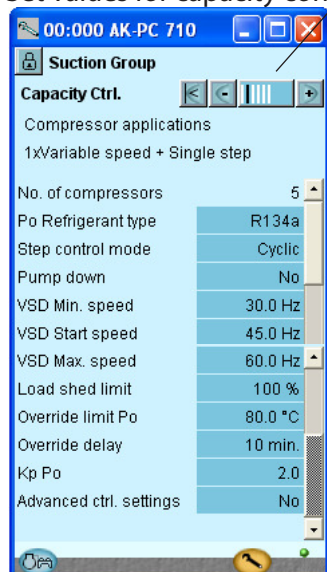

In our example we select:  
 - Refrigerant = R134a  
 - Equalisation of working hours  
 - Value for speed regulation  
 Speed regulation can always only be on compressor number 1.  
 The settings are shown here in the display.

*Not all compressors can have their speed adjusted. If there is any doubt, contact your compressor supplier.*

If you want to know more about the different configuration options, they are listed below.

The number refers to the number and picture in the column on the left.

The screen only shows the settings and readings that are required for a given set-up.

#### 3 - Po-Reference

Reference = set reference + night offset + offset from P0 optimization

**Setpoint** (-80 to +30°C)

Setting of required suction pressure in °C

**Night Offset** (-25 to +25 K)

Displacement value for suction pressure in connection with an active night setback signal (set in Kelvin)

Changing to night-time operation can be carried out with a signal sent via the data communication, with a signal on the input "night" or via the weekly schedule in the controller.

**Max reference** (-50 to +80 °C)

Max. permissible suction pressure reference

**Min reference** (-80 to +25 °C)

Min. permissible suction pressure reference

#### 4 - Compressor application

**Po refrigerant type**

Select refrigerant type

**Po refrigerant factors K1, K2, K3**

Only used if "Po refrigerant type" is set to custom (contact Danfoss for information)

**Step control mode**

Select coupling pattern for compressors

Sequential: Compressors are cut in/out in strict accordance with compressor number (FILO)

Cyclic: Runtime equalisation between compressors (FIFO) (same sized compressors)

Best fit: Compressors are cut in/out in order to make the best possible fit to actual load (different sized compressors)

**Pump down**

Select whether a pump down function is required on the last running compressor

**Pump down limit** (-80 to +30 °C)

Set the actual pump down limit for the last compressor

**VSD min speed** (0.5 – 60.0 Hz)

Min. speed where the compressor must cutout

**VSD start speed** (20.0 – 60.0 Hz)

Minimum speed for start of Variable speed drive (Must be set higher than "VSD Min. Speed Hz")

**VSD max speed** (40.0 – 120.0 Hz)

Highest permissible speed for the compressor motor

**Load shed limit**

Set max capacity limit for load shed Load Shed"

**Override limit Po**

If the P0 exceeds the value, a time delay is started. If the time delay runs out, the load limit is cancelled

**Override delay**

Max. time for capacity limit, if P0 is too high

**Kp Po** (0.1 – 10.0)

Amplification factor for P0 regulation

**Advanced control settings**

Select whether the adv. settings must be visible

**Min. capacity change** (0 – 100 %)

Set the minimum capacity change needed before the capacity distributor connects or disconnects compressors

**Minimize cycling**

The control zone may vary for connections and disconnections. See Section 5.

**Initial start time** (15 – 900 s)

The time after start-up where the cut-in capacity is limited to the first compressor step.

Press the +-button to go on to the next page

### 5. Set values for capacity of the compressors

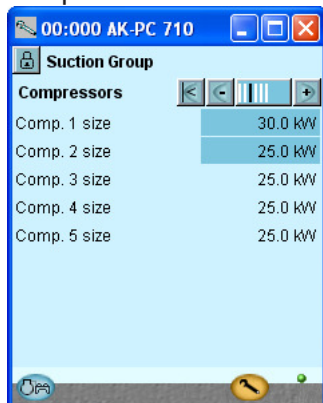

Press the +-button to go on to the next page

### 6. Set values for safe operation



Press the +-button to go on to the next page

In our example we select:  
 - Speed-controlled compressor of 30 kW (compressor 1)  
 - Four compressors of 25 kW  
 The example settings are shown here in the display.

(For cyclic operation, all one-step compressors have the same size. This is why there is only one setting, but it covers all 4.)

In our example we select:  
 - Safety limit for discharge temperature = 120°C  
 - Safety limit for high condensing pressure = 50°C  
 - Safety limit for low suction pressure = -35°C  
 - Alarm limit for high suction pressure = -5°C  
 - Alarm limit for min. and max. superheat, respectively = 5 and 35 K.

#### 5 - Compressors

In this screen the capacity distribution between the compressors is defined.

Capacities that need to be set depend upon the "compressor application" and "Step control mode" that has been selected.

##### Nominal capacity (0.0 – 99.9 kW)

Set the nominal capacity for the compressor in question. For compressors with variable speed drive the nominal capacity must be set for the mains frequency (50/60 Hz)

#### 6 - Safety

##### Delay time for liquid level alarm

Set the delay time (from the time the signal is lost on the input to the time when the alarm is sent)

##### Delay time for VSD-alarm

Set the delay time

##### Temperature alarm limit

Set the threshold value for the temperature alarm

##### Delay time for the temperature alarm

Set the delay time

##### Emergency cap. day

The desired cut-in capacity for daily use in the case of emergency operations resulting from error in the suction pressure sensor/ media temperature sensor.

##### Emergency cap. night

The desired cut-in capacity for night operations in the case of emergency operations resulting from error in the suction pressure sensor/ media temperature sensor.

##### Sd max limit

Max. value for discharge gas temperature 10 K below the limit, the compressor capacity should be reduced and the entire condenser capacity will be cutin. If the limit is exceeded, the entire compressor capacity will be cutout

##### Pc Max limit

Maximum value for the condenser pressure in °C 3 K below the limit, the entire condenser capacity will be cutin and the compressor capacity reduced. If the limit is exceeded, the entire compressor capacity will be cutout.

##### Pc Max delay

Time delay for the alarm Pc max

##### P0 Min limit

Minimum value for the suction pressure in °C If the limit is reduced, the entire compressor capacity will be cutout.

##### P0 Max alarm

Alarm limit for high suction pressure P0

##### P0 Max delay

Time delay before alarm for high suction pressure P0.

##### Safety restart time

Common time delay before restarting the compressor. (Applicable to the functions: "Sd max. limit", Pc max. limit" and "P0 min. limit).

##### SH Min alarm

Alarm limit for min. superheat in suction line.

##### SH Max alarm

Alarm limit for max. superheat in suction line.

##### SH alarm delay

Time delay before alarm for min./max. superheat in suction line.

### 7. Set operation time for compressor



Press the + -button to go on to the next page

### 8. Set times for safety cutouts



Set min. OFF-time for the compressor relay  
 Set min. ON-time for the compressor relay  
 Set how often the compressor is allowed to start

#### 7 - Minimum operation times

Configure the operation times here so "unnecessary operation" can be avoided.

##### Min. OFF time

The time the compressor should be idle before it should start again.

##### Min. ON time

The time the compressor should operate before it should stop.

##### Restart time

The lowest time interval between two consecutive starts.

#### 8 - Safety timer

##### Cutout delay

The time delay resulting from drop-out of automated safety measures and until the compressor-error is reported.

##### Restart delay

Minimum time that a compressor should be OK after a safety cut-out. After this interval it can start again.

(An alarm which is triggered by the automatic safety function will be maintained until the restart delay has expired.)

If the restrictions overlap, the controller will use the longest restriction time.

## Setup control of condenser

1. Go to Configuration menu
2. Select Condenser

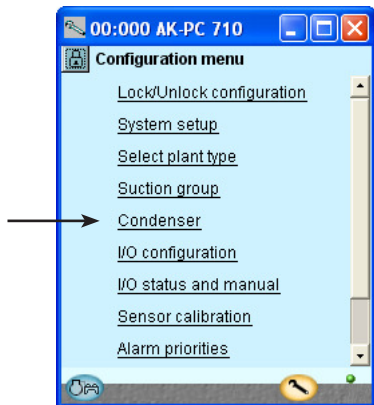

3. Set control mode and reference

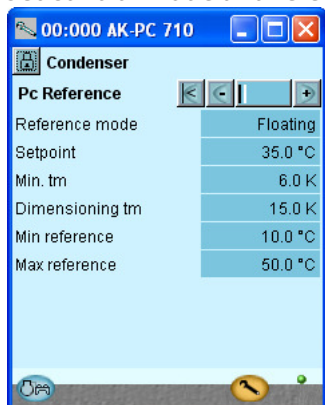

In our example the condenser pressure is controlled on the basis of the outdoor temperature (floating reference). The settings shown here in the display.

 Press the + -button to go on to the next page

4. Set values for capacity regulation

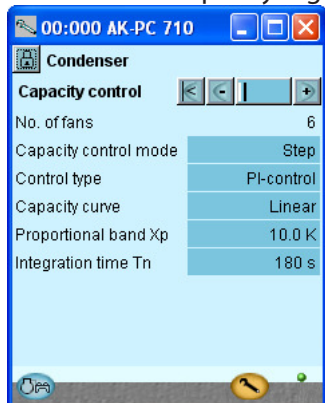

Used in our example are six step-controlled fans. The settings shown here in the display.

### 3 - PC reference Reference Mode

Choice of condenser pressure reference  
Fixed setting: Used if a permanent reference is required = "Setting"

Floating: Used if the reference is changed as a function of Sc3 the external temperature signal, the configured "Dimensioning tm K"/"Minimum tm K" and the actual cut in compressor capacity.

#### Setpoint

Setting of desired condensing pressure in °C. It should also be set when floating references are used. The value is used as a reference if the Sc3 sensor becomes defective.

#### Min. tm

Minimum average temperature difference between Sc3 air and Pc condensing temperature when no compressors are in operation.

#### Dimensioning tm

Dimensioning average temperature differential between Sc3 air and Pc condensing temperature at maximum load (tm difference at max load, typically 8-15 K).

#### Min reference

Min. permitted condenser pressure reference

#### Max reference

Max. permitted condenser pressure reference

### 4 - Capacity control

#### Capacity control mode

Select control mode for condenser

Step: Fans are step-connected via relay outputs

Step/speed: The fan capacity is controlled via a combination of speed control and step coupling

Speed: The fan capacity is controlled via speed control (frequency converter)

#### Control type

Choice of control strategy

P-band: The fan capacity is regulated via P-band control. The P band is configured as "Proportional band Xp"

PI-Control: The fan capacity is regulated by the PI controller.

#### Capacity curve

Choice of capacity curve type

Linear: The same amplification in the entire area

Square: Square curve shape, which gives higher amplification at higher loads.

#### VSD start speed

Minimum speed for start of speed control (Must be configured higher than "VSD Min. Speed %")

#### VSD min Speed

Minimum speed whereby speed control is cut-out (low load).

#### Proportional band Xp

Proportional band for P/PI controller

#### Integration time Tn

Integration time for PI controller



## Configuration of inputs and outputs

1. Go to Configuration menu

2. Select I/O configuration

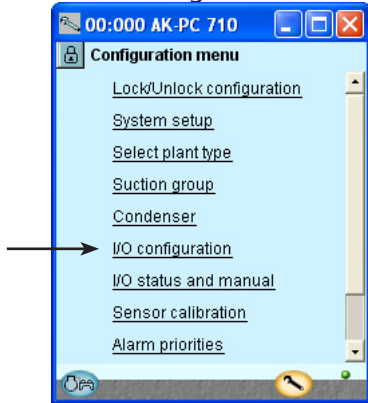

3. Configuration of Digital outputs

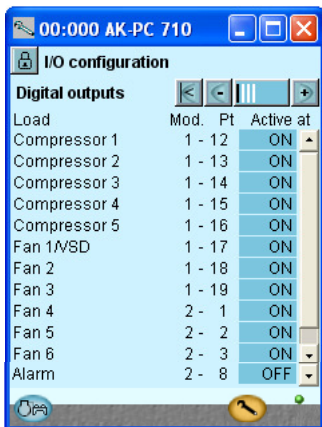

The outputs are enabled by On (relay activated)

!!! The alarm is inverted so that there will be an alarm if the supply voltage to the controller fails.

Press the +-button to go on to the next page

4. Setup On/off input functions

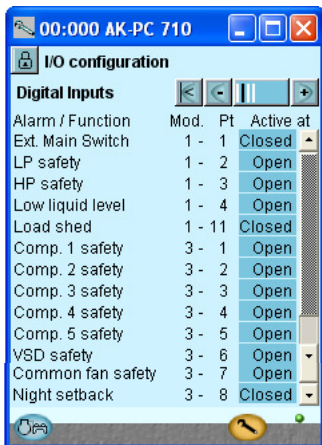

Press the +-button to go on to the next page

Select for each input whether the function is to be active when the input is in pos. **Closed** or **Open**. Open has been selected here for all the safety circuits. This means that the controller will receive signal under normal operation and register it as a fault if the signal is interrupted.

### 5. Configuration of Analog outputs

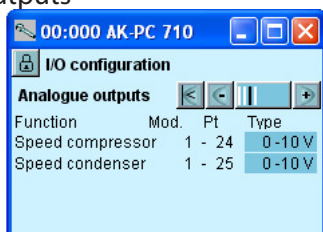

Press the + -button to go on to the next page

We set up the analog outputs for control of the compressor speed.

#### 5 - Analog outputs

The possible signals are the following:

- 0 -10 V
- 2 - 10V
- 0 - 5 V
- 1 - 5V

#### 6 - Analog inputs

The possible signals are the following:

- Temperature sensors:
- Pt1000
  - PTC 1000

Pressure transmitters:

- AKS 32, -1 - 6 Bar
- AKS 32R, -1 - 6 Bar
- AKS 32, - 1 - 9 Bar
- AKS 32R, -1 - 9 Bar3
- AKS 32, - 1 - 12 Bar
- AKS 32R, -1 - 12 Bar
- AKS 32, - 1 - 20 Bar
- AKS 32R, -1 - 20 Bar
- AKS 32, - 1 - 34 Bar
- AKS 32R, -1 - 34 Bar
- AKS 32, - 1 - 50 Bar
- AKS 32R, -1 - 50 Bar
- AKS 2050, -1 - 59 Bar
- AKS 2050, -1 - 99 Bar
- AKS 2050, -1 - 159 Bar
- Customised ratiometric application: Here, the transmitters min. and max. pressure areas are set (relative pressure reading)

### 6. Configuration of Analog Input signals

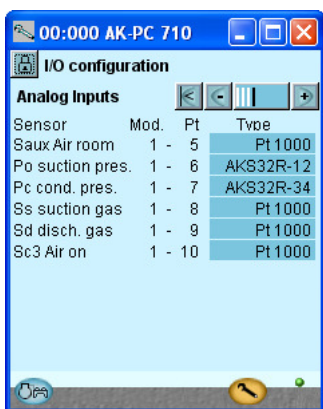

We set up the analog inputs for the sensors.

## Set alarm priorities

1. Go to Configuration menu

2. Select Alarm priorities

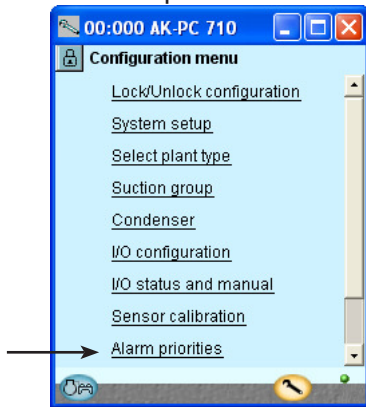

3. Set priorities for Suction group

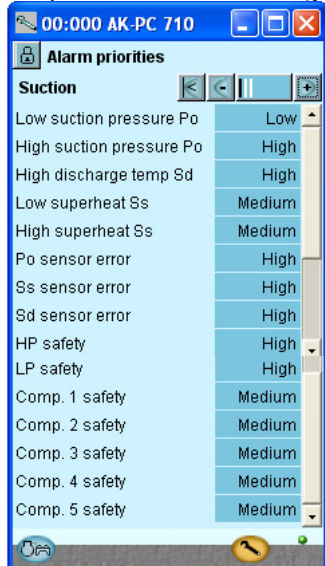

Press the + -button to go on to the next page

4. Set alarm priorities for condenser



Press the + -button to go on to the next page

Very many functions have an alarm connected.

Your choice of functions and settings has connected all the relevant alarms that are current. They will be shown with text in the three pictures.

All alarms that can occur can be set for a given order of priority:

- "High" is the most important one
- "Log only" has lowest priority
- "Disconnected" gives no action

The interdependence between setting and action can be seen in the table.

Setting	Log	Alarm relay	Network	AKM- dest.
High	X	X	X	1
Medium	X		X	2
Low	X		X	3
Log only	X			4
Disconnected				

In our example we select the settings shown here in the display

In our example we select the settings shown here in the display



### 5. Set alarm priorities for temperature alarm and Digital signals

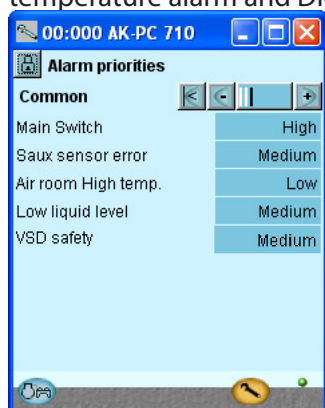

In our example we select the settings shown here in the display

## Lock configuration

1. Go to Configuration menu

2. Select Lock/Unlock configuration

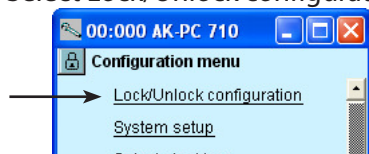

3. Lock Configuration

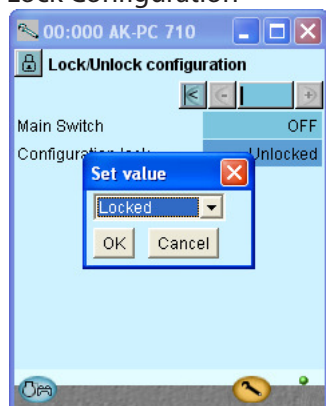

The controller will now make a comparison of selected functions and define inputs and outputs. The result can be seen in the next section where the setup is controlled.

Press in the field against **Configuration lock**.

Select **Locked**.

Press **OK**.

The setup of the controller has now been locked. If you subsequently want to make any changes in the controller's setup, remember first to unlock the configuration.

## Check configuration

1. Go to Configuration menu
2. Select I/O configuration

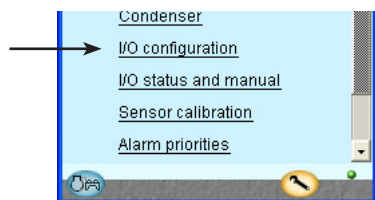

3. Check configuration of Digital Outputs

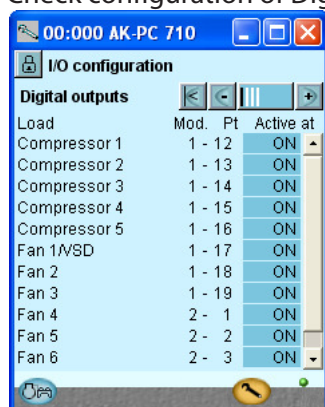

Press the + -button to go on to the next page

4. Check configuration of Digital Inputs

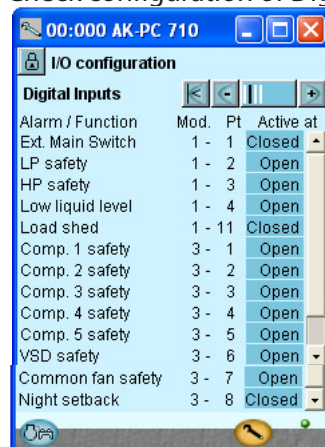

Press the + -button to go on to the next page

***This control requires that the setup is locked***

(Only when the setup is locked are all settings for in- and outputs activated.)

**An error has occurred, if you see the following:**



A **0 - 0** next to a defined function. If a setting has reverted to 0-0, you must control the setup again.

The error is caused by the two modules connected to the controller being switched.

### 5. Check configuration of Analog Outputs

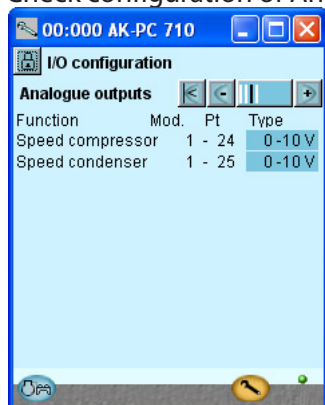

(If no speed control of the condenser fans is used, the module and point number can be 0-0.)

 Press the +-button to go on to the next page

### 6. Check configuration of Analog Inputs

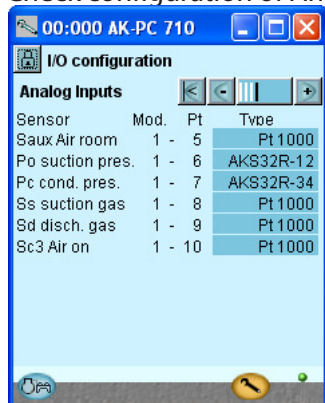

# Check of connections

1. Go to Configuration menu

2. Select I/O status and manual

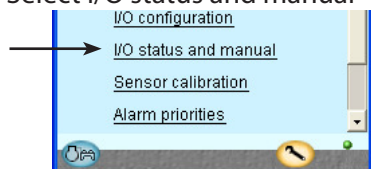

3. Check Digital Outputs

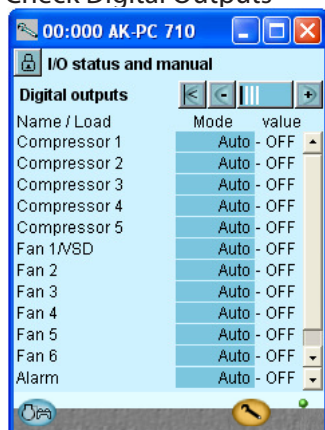

Press the +-button to go on to the next page

4. Check Digital Inputs

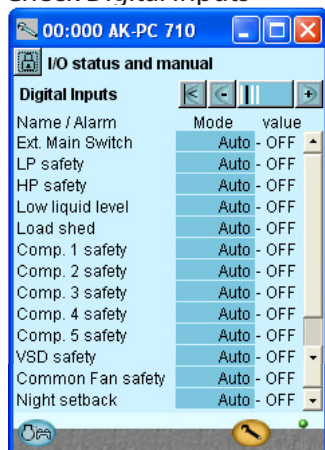

Press the +-button to go on to the next page

Before the control is started we check that all inputs and outputs have been connected as expected.

***This controls requires that the setup is locked***

By means of the manual control of each output it can be checked whether the output has been correctly connected.

- AUTO**            The output is controlled by the controller
- MAN OFF**        The output is forced to pos. OFF
- MAN ON**         The output is forced to pos ON

Cut out the safety circuit for compressor 1.  
Check that LED DI1 on the extension module (module 3) goes out.

Check that the value of the alarm for the safety monitoring of compressor 1 changes to **ON**.  
The remaining digital inputs are checked in the same way.

### 5. Check Analog outputs

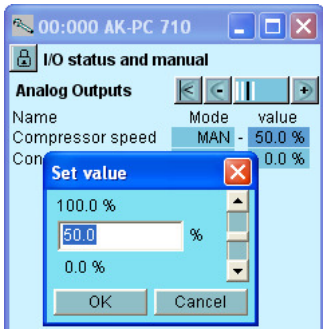
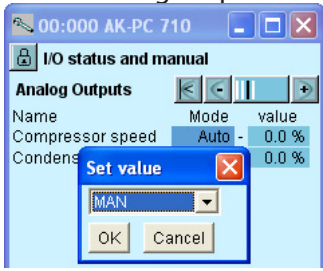

### 6. Put the control of the output voltage back to automatic

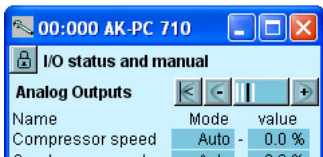

Press the + -button to go on to the next page

### 7. Check Analog inputs

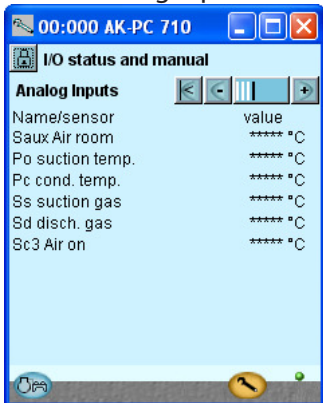

Set Control of output voltage to manual  
Press in the **Mode** field.

Select **MAN**.

Press **OK**.

Press in the **Value** field  
Select for example **50%**.

Press **OK**.

On the output you can now measure the expected value: In this example 5 volts

Example of the connection between a defined output signal and a manual set value.

Definition	Setting		
	0 %	50 %	100 %
<b>0 - 10 V</b>	0 V	5 V	10 V
<b>1 - 10 V</b>	1 V	5.5 V	10 V
<b>0 - 5 V</b>	0 V	2.5 V	5 V
<b>2 - 5 V</b>	2 V	3.5 V	5 V

Check that all sensors show sensible values.

In our case we have no value for the suction gas temperature Ss and the two sensors. This may be due to the following:

- The sensor has not been connected.
- The sensor is short-circuited.
- The point or module number has not been set up correctly.
- The configuration is not locked.

# Check of settings

1. Go to the overview

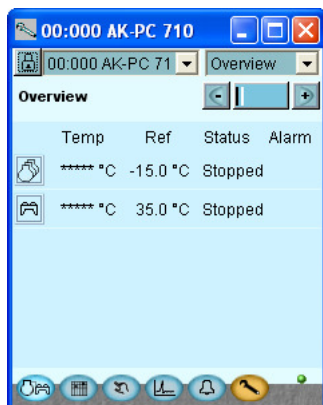

2. Select suction group



3. Move on through all the individual displays for the suction group



Change displays with the +- button. Remember the settings at the bottom of the pages – the ones that can only be seen via the "Scroll bar".

4. Safety limits

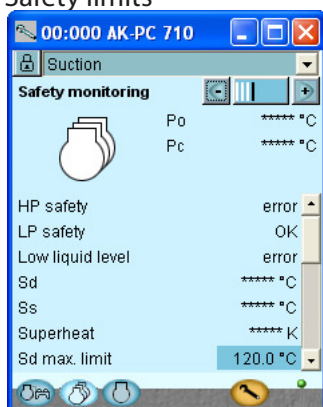

5. Go back to the overview



6. Select condenser group



Before the control starts, we check that all the settings are as they should be.

The overview display will now show one line for each of the general functions. Behind each icon there is a number of displays with the different settings. It is all these settings that have to be checked.

The last page contains safety limits and restart times.

7. Move on through all the individual displays for the condenser group.



Change displays with the +- button. Remember the settings at the bottom of the pages – the ones that can only be seen via the "Scroll bar".

8. Safety limits

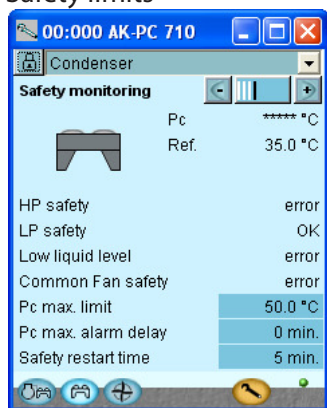

9. The controller setup has been completed.

The last page contains safety limits and restart times.



# Schedule function

1. Go to Configuration menu



2. Select schedule



3. Setup schedule

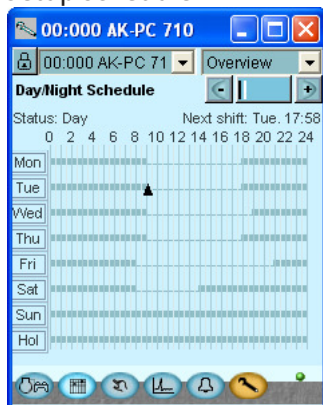

For your information

This setting is not necessary in the example. The signal comes in via DI8.

In other cases where the controller is installed in a network with one system unit, this setting may be made in the system unit which will then transmit a day/night signal to the controller.

This setting can only be used, if the controller stands alone and is fitted with a clock module.

Press a weekday and set the time for the day period.

Continue with the other days.

A complete weekly sequence is shown in the display.

# Installation in network

## 1. Set the address (here, for example 3)

Turn the right-hand address switch so that the arrow will point at 3.

The arrow of the two other address switches must point at 0.

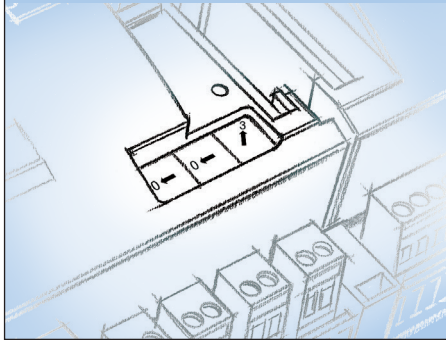

## 2. Push the Service Pin

Press down the service pin and keep it down until the Service Pin LED lights up.

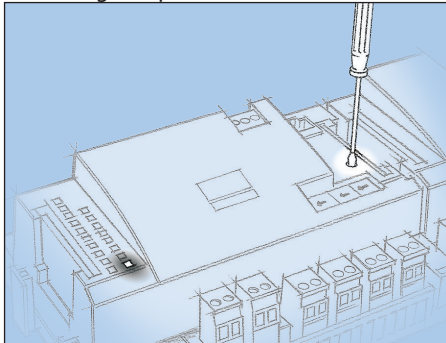

## 3. Wait for answer from the system unit

Depending on the size of the network it may be up to one minute before the controller receives an answer as to whether it has been installed in the network.

When it has been installed the Status LED will start to flash faster than normal (once every half second). It will continue with this for about 10 minutes

## 4. Carry out new login via Service Tool



If the Service Tool was connected to the controller while you installed it in the network, you must carry out a new login to the controller via the Service Tool.

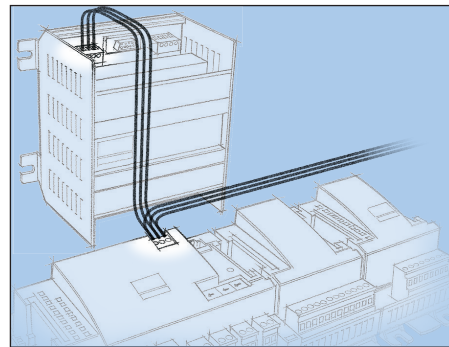

The controller has to be remote-monitored via a network. In this network we assign address number 3 to the controller.

The same address must not be used by more than one controller in the same network.

### Requirement to the system unit

The system unit must be a gateway type AKA 245 with software version 6.0 or higher. It is capable of handling up to 119 AK controllers.

Alternatively, it can be an AK-SM 720. It is capable of handling up to 200 AK controllers.

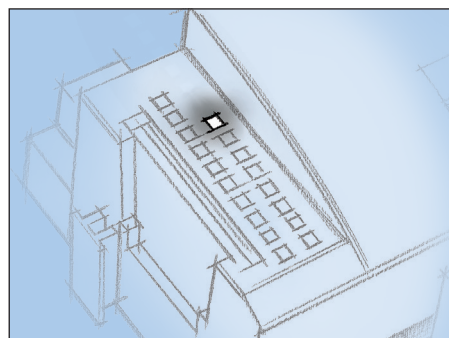

### If there is no answer from the system unit

If the Status LED does not start flashing faster than normal, the controller has not been installed in the network. The reason for this may be one of the following:

#### The controller has been assigned an address out of range

Address 0 cannot be used.

If the system unit in the network is an AKA 243B Gateway only the addresses between 1 and 10 can be used.

#### The selected address is already being used by another controller or unit in the network:

The address setting must be changed to another (vacant) address.

#### The wiring has not been carried out correctly.

#### The termination has not been carried out correctly.

The data communication requirements are described in the document: "Data communication connections to ADAP-KOOL® Refrigeration Controls" RC8AC.

# First start of control

## Check alarms

1. Go to the overview



Press the blue overview button with the compressor and condenser at the bottom left of the display.

2. Go to the Alarm list



Press the blue button with the alarm bell at the bottom of the display.

3. Check active alarms

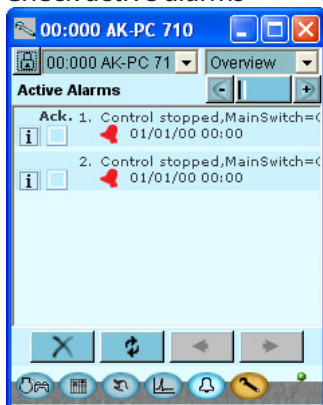

In our case, we have a series of alarms. We will tidy them up so that we only have those that are relevant.

4. Remove cancelled alarm from the alarm list



Press the red cross to remove cancelled alarms from the alarm list.

5. Check active alarm again

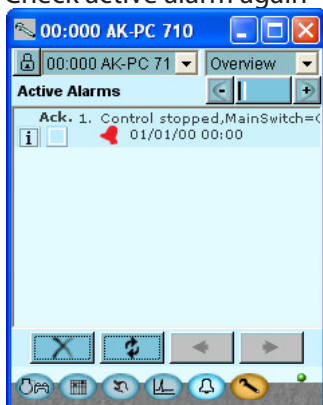

In our case an active alarm remains because the control has stopped. This alarm must be active when control has not started. We are now ready for the startup of control.

Please note that active plant alarms are automatically cancelled when the main switch is in pos. OFF. If active alarms appear when the control is started the reason for these should be found and remedied.

## Start the control

### 1. Go to Start/Stop display



Press the blue manual control button at the bottom of the display.

### 2. Start control

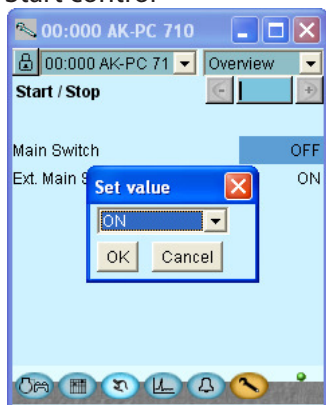

Press in the field against **Main switch**.

Select **ON**.

Press **OK**.

The controller will now start controlling the compressors and the fans.

Note:

Control does not start until both the internal and external switch are "ON".

## Manual capacity control

### 1. Go to overview



### 2. Select suction group



Press the suction group button for the suction group that is to be controlled manually.



Press the +-button to go on to the next page

### 3. Set capacity control to manual

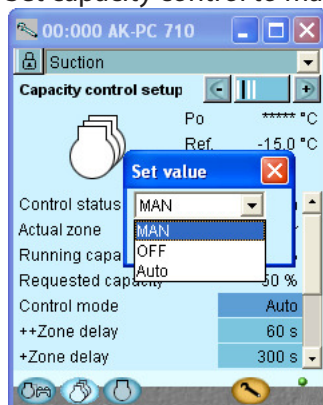

If you need to manually adjust the capacity of the compressors, you can use the following procedure:

Press the blue field against **Control mode**  
Select **MAN**.  
Press **OK**.

### 4. Set capacity in percent

Press in the blue field against **Manual capacity**.

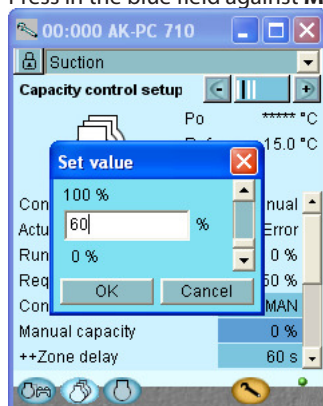

Set the capacity to the required percentage.  
Press **OK**.

## Quick setup

It is advantageous for the installer, familiar with the controller, to follow the following procedure:

1. Unlock the configuration
2. Select application (service tool then closes down)
3. Select refrigerant
4. Set the compressor sizes (only if they are different)
5. Lock the configuration
6. Check inputs and outputs
7. Turn main switch ON.

## EKA 164, EKA 166 or AKM operation

The controller's functions as can be seen via display EKA 164, EKA 166 and via system software type AKM are shown on the following pages.

For access to parameters, press and hold the top button.

EKA-text	AKM text	R/W	Description / Parameter	Range	Default
<b>Reference</b>					
r01	Neutral zone K	W	Width of neutral zone for compressor control	0,1 – 20,0 K	6,0 K
r04	Po sensor adjust	W	Calibration of Po sensor	-10,0 - 10,0 Bar	0,0 bar
r12	Main switch	W	"Main switch for start/stop of control ON: Normal control OFF: Control is stopped"	"ON: Normal control OFF: Control is stopped"	OFF
r13	Night offset K	W	Displacement value for suction pressure in connection with an active night setback signal (set in Kelvin)	-25,0 - 25,0 K	0,0 K
r23	Po setpoint °C	W	Setting of required reference pressure in °C	-80,0 °C - 30,0 °C	-15,0 °C
r24	Comp. ctrl. Ref. °C	R	Actual reference temp. for compressor capacity (incl. external reference signal, if any)		
r25	Max reference °C	W	Max. permissible suction pressure reference	-50,0 °C - 80,0 °C	80,0 °C
r26	Min Reference °C	W	Min. permissible suction pressure reference	-80,0 °C - 25,0 °C	-80,0 °C
r27	Night setback	R	Actual status of night setback	ON/OFF	
r28	Pc setpoint °C	W	Setting of desired condensing pressure in °C	-25,0 °C - 90,0 °C	35,0 °C
r29	Cond. ctrl. Ref. °C	R	Reference for condenser in °C		
r30	Min Reference °C	W	Min. permitted condenser pressure reference	-25,0 °C - 100,0 °C	10,0 °C
r31	Max Reference °C	W	Max. permitted condenser pressure reference	-25,0 °C - 100,0 °C	50,0 °C
r32	Pc sensor adjust	W	Calibration of Pc sensor	-10,0 - 10,0 Bar	0,0 bar
r33	Pc Reference mode	W	"Choice of condenser pressure reference 0: Reference = Pc setpoint 1: The reference is changed as a function of Sc3 the external temperature signal"	"0: Pc setpoint 1: Floating"	1: Floating
r35	Dimensioning tm K	W	Dimensioning mean temperature differential between Sc3 air and Pc condensing temperature at maximum load (compressor capacity = 100%). Dimensioning temp difference at max load, typically 8-15 K).	0,0 - 25,0 K	15,0 K
r56	Min tm K	W	Minimum mean temperature difference between Sc3 air and Pc condensing temperature at no load (Compressor capacity = 0%)	0,0 - 20,0 K	6,0 K
r57	Po °C	R	Suction pressure in °C. (Measured with the Po pressure transmitter)		
<b>Capacity control</b>					
c08	Step mode	W	"Select coupling pattern for compressors 0: Sequential: Compressors are cut in/out in strict accordance with compressor number (FILO) 2: Cyclic: Runtime equalisation between compressors (FIFO) 3: Best fit: Compressors are cut in/out in order to make the best possible fit to actual load"	"0: Sequential 2: Cyclic 3: Best fit "	2: Cyclic
c10	+ Zone band K	W	Width of "+ Zone" above neutral zone	0,1 – 20,0 K	4,0 K
c11	+ Zone delay s	W	Integrationtime in "+ Zone"	10,0 – 900,0 s	300 s
c12	++ Zone delay s	W	Integrationtime in "++ Zone"	10,0 – 900,0 s	300 s
c13	- Zone band K	W	Width of "- Zone" below neutral zone	0,1 – 20,0 K	3,0 K
c14	- Zone delay s	W	Integrationtime in "- Zone"	10,0 – 900,0 s	150 s
c15	-- Zone delay s	W	Integrationtime in "-- Zone"	1,0 – 300,0 s	30 s
c16	Comp. application	R	Readout compressor combinations	0: Single step only 4: 1 x variable speed + single step	0: Single step only
c29	No. of fans	R	Read out number of fans	0 - 6	0
c31	Manual capacity %	W	"Manual setting of compressor capacity The value is in % of total capacity controlled by the controller"	0 - 100%	0%
c32	Cap. control mode	W	Select whether capacity control is stopped, in manual control or controlled via PI controller	0: Manual control 1: OFF 2: Auto	2: Auto
c33	Po pump down limit °C	W	Set the actual pump down limit for the last compressor	-80,0 °C - 30,0 °C	-40,0 °C
c35	Load shed limit 1	W	Set max compressor capacity limit for load shed input	0 - 100%	100%

c36	Override limit Po	W	Any load below the limit value is freely permitted. If the suction pressure Po exceeds the value, a time delay is started. If the time delay runs out, the load limit is cancelled	-50,0 °C - 80,0 °C	80,0 °C
c37	Override delay 1 min	W	Max. time for capacity limit, if Po is too high	0 - 240 min	10 min
c38	Pump down	W	Select whether a pump down function is required on the last running compressor	0: No 1: Yes	0: No
c39	Initial start time	W	The time after start-up where the cut-in capacity is limited to the first compressor step.	0 - 900 sec	120 sec
c40	Compressor 1 size	W	"Set the nominal capacity for the compressor in question. For compressors with variable speed drive the nominal capacity must be set for the mains frequency (50/60 Hz) Set the nominal capacity for the compressor in question."	0,0 - 99,9 kW	0 kW
c41	Compressor 2 size	W	Set the nominal capacity for the compressor in question.	0,0 - 99,9 kW	0 kW
c42	Compressor 3 size	W	Set the nominal capacity for the compressor in question.	0,0 - 99,9 kW	0 kW
c43	Compressor 4 size	W	Set the nominal capacity for the compressor in question.	0,0 - 99,9 kW	0 kW
c44	Compressor 5 size	W	Set the nominal capacity for the compressor in question.	0,0 - 99,9 kW	0 kW
c45	Compressor 6 size	W	Set the nominal capacity for the compressor in question.	0,0 - 99,9 kW	0 kW
c46	VSD Min speed Hz	W	Min. speed where the compressor must cutout	0,5 Hz	60,0 Hz
c47	VSD Start speed Hz	W	Minimum speed for start of Variable speed drive (Must be set higher than "VSD Min. Speed Hz")	20,0 Hz	60,0 Hz
c48	VSD Max speed Hz	W	Highest permissible speed for the compressor motor	40,0 Hz	120,0 Hz
c49	Emergency cap day%	W	The desired cut-in capacity for daily use in the case of emergency operations resulting from error in the suction pressure sensor/ media temperature sensor	0 - 100%	50%
c50	Emergency cap. night%	W	The desired cut-in capacity for night operations in the case of emergency operations resulting from error in the suction pressure sensor/ media temperature sensor.	100%	25%
<b>Compressor timers</b>					
c51	Comp. 1 Min. ON-time	W	Minimum duration of ON period	0 - 60 min	0 min
c52	Comp. 2 Min. ON-time	W	Minimum duration of ON period	0 - 60 min	0 min
c53	Comp. 3 Min. ON-time	W	Minimum duration of ON period	0 - 60 min	0 min
c54	Comp. 4 Min. ON-time	W	Minimum duration of ON period	0 - 60 min	0 min
c55	Comp. 5 Min. ON-time	W	Minimum duration of ON period	0 - 60 min	0 min
c56	Comp. 6 Min. ON-time	W	Minimum duration of ON period	0 - 60 min	0 min
c57	Comp. 1 Min. OFF-time	W	Minimum duration of OFF periode	0 - 30 min	0 min
c58	Comp. 2 Min. OFF-time	W	Minimum duration of OFF periode	0 - 30 min	0 min
c59	Comp. 3 Min. OFF-time	W	Minimum duration of OFF periode	0 - 30 min	0 min
c60	Comp. 4 Min. OFF-time	W	Minimum duration of OFF periode	0 - 30 min	0 min
c61	Comp. 5 Min. OFF-time	W	Minimum duration of OFF periode	0 - 30 min	0 min
c62	Comp. 6 Min. OFF-time	W	Minimum duration of OFF periode	0 - 30 min	0 min
c63	Comp. 1 Recycle time	W	Minimum period between two successive compressor starts	1 - 60 min	6 min
c64	Comp. 2 Recycle time	W	Minimum period between two successive compressor starts	1 - 60 min	6 min
c65	Comp. 3 Recycle time	W	Minimum period between two successive compressor starts	1 - 60 min	6 min
c66	Comp. 4 Recycle time	W	Minimum period between two successive compressor starts	1 - 60 min	6 min
c67	Comp. 5 Recycle time	W	Minimum period between two successive compressor starts	1 - 60 min	6 min
c68	Comp. 6 Recycle time	W	Minimum period between two successive compressor starts	1 - 60 min	6 min
<b>Neutral zone control</b>					
n04	Xp P-band K	W	Proportional band for condenser P/PI controller	0,0 - 100,0 K	10,0 K
n05	Tn Integr. time s	W	Integration time for condenser PI controller	30 - 600 sec	180 sec
n20	Kp Po	W	Amplification factor for compressor capacity control	0,1 - 10,0	2
n52	Control mode	W	"0: MAN (The condenser capacity will be controlled manually) 1: OFF (The capacity control will be stopped) 2: AUTO (The capacity is controlled by the PI controller)"	0: Manual control 1: OFF 2: Auto	2: Auto
n53	Manual capacity %	W	Manual setting of condenser capacity	0 - 100%	0%
n54	VSD Start speed %	W	Condenser minimum speed for start of speed control (Must be configured higher than "VSD Min. Speed %")	0,0 - 40,0 %	20,0%
n55	VSD Min. speed %	W	Condenser minimum speed whereby speed control is cut-out (low load).	0,0 - 40,0 %	10,0%



n94	Step/speed	W	"Select control mode for condenser 0: Step: Fans are step-connected via relay outputs 1: Step/speed: The fan capacity is controlled via a combination of speed control and step coupling 2: Speed: The fan capacity is controlled via speed control (frequency converter)"	0: Step control 1: Step/Speed 2: Speed	0: Step
n95	Control type	W	"Choice of control strategy for condenser 0: P-band: The fan capacity is regulated via P-band control. The P band is configured as ""Proportional band Xp"" 1: PI-Control: The fan capacity is regulated by the PI controller"	0: P-band control 1: PI control	1: PI control
<b>Alarm/Safety Settings</b>					
A03	Saux 1 High alarm del	W	Alarm delay for high Saux temperature	0 - 360 min	5 min
A10	Po Max alarm °C	W	Alarm limit for high suction pressure Po	-30,0 °C - 100,0 °C	100,0 °C
A11	Po Min limit °C	W	"Minimum value for the suction pressure in °C If the limit is reduced, the entire compressor capacity will be cutout."	-120,0 °C - 30,0 °C	-40,0 °C
A28	Low liquid level delay	W	Time delay for the low liquid level alarm	0 - 360 min	5 min
A30	Pc Max limit °C	W	"Maximum value for the condenser pressure in °C 3 K below the limit, the entire condenser capacity will be cutin and the compressor capacity reduced. If the limit is exceeded, the entire compressor capacity will be cutout."	-30,0 °C - 100,0 °C	50,0 °C
A35	Saux 1 High alarm °C	W	High temp. alarm limit for Saux sensor	-80,0 °C - 120,0 °C	120,0 °C
A44	Po Max delay m	W	Time delay before alarm for high suction pressure P0.	0 - 240 min	5 min
A45	Pc Max alarm delay m	W	Time delay for the alarm Pc max	0 - 240 min	0 min
A58	Sd max limit °C	W	"Max. value for discharge gas temperature 10 K below the limit, the compressor capacity should be reduced and the entire condenser capacity will be cutin. If the limit is exceeded, the entire compressor capacity will be cutout"	-0,0 °C - 150,0 °C	80,0 °C
A59	SH min alarm K	W	Alarm limit for min. superheat in suction line.	0,0 - 20,0 K	0,0 K
A60	SH max alarm K	W	Alarm limit for max. superheat in suction line.	20,0 - 80,0 K	80,0 K
A61	SH alarm delay	W	Time delay before alarm for min./max. superheat in suction line.	0 - 60 min	5 min
A62	Safety restart time m	W	"Common time delay before restarting the compressor. (Applicable to the functions: ""Sd max. limit"", Pc max. limit"" and ""P0 min. limit)."	0 - 60 min	5 min
A64	VSDcutoutDel	W	Time delay before VSD alarm	0-360 min	5 min
<b>Miscellaneous</b>					
o12	Mains frequency	W	Select frequency of the power supply	0: 50 Hz 1: 60 Hz	0: 50 Hz
o19	No. of compressors	R	Readout number of compressors	0 - 6	0
o21	Po sensor	W	Select sensor type for Po 0: User defined, 1=AKS32-6, 2=AKS32R-6, 4=AKS32-9, 5=AKS32R-9, 7=AKS32-12, 8=AKS32R-12, 10=AKS32-20, 11=AKS32R-20, 13=AKS32-34, 14=AKS32R-34, 16=AKS32-50, 17=AKS32R-50, 31=AKS2050-59, 32=AKS2050-99, 33=AKS 2050-159	0-33	8
o23	Comp. 1 Runtime	W	Compressor's total run time in hours	0 - 999999 h	0 h
o24	Comp. 2 Runtime	W	Compressor's total run time in hours	0 - 999999 h	0 h
o25	Comp. 3 Runtime	W	Compressor's total run time in hours	0 - 999999 h	0 h
o26	Comp. 4 Runtime	W	Compressor's total run time in hours	0 - 999999 h	0 h
o30	Refrigerant type	W	Select refrigerant type for Po 1=R12, 2=R22, 3=134a, 4=R502, 5=R717, 6=R13, 7=R13b1, 8=R23, 9=R500, 10=R503, 11=R114, 12=R142b, 13=User def., 14=R32, 15=R227, 16=R401A, 17=R507, 18=R402A, 19=R404A, 20=R407C, 21=R407A, 22=R407B, 23=R410A, 24=R170, 25=R290, 26=R600, 27=R600a, 28=R744, 29=R1270, 30=R417A 31=R422A, 32=R413A, 33=R422D, 34=R427A, 35=R438A, 36=XP10, 37=R407F	0: None	37
o48	Pc sensor	W	Select sensor type for Po 0: User defined, 1=AKS32-6, 2=AKS32R-6, 4=AKS32-9, 5=AKS32R-9, 7=AKS32-12, 8=AKS32R-12, 10=AKS32-20, 11=AKS32R-20, 13=AKS32-34, 14=AKS32R-34, 16=AKS32-50, 17=AKS32R-50, 31=AKS2050-59, 32=AKS2050-99, 33=AKS 2050-159	0-33	14
o50	Comp. 5 Runtime	W	Compressor's total run time in hours	0 - 999999 h	0 h
o51	Comp. 6 Runtime	W	Compressor's total run time in hours	0 - 999999 h	0 h
o61	Quick setup select	W	"Select a predefined application. Gives a choice between a number of predefined applications, which at the same time determine the wiring connection points. (see manual for further details)"	See documentation for quick selections	0: None selected
o93	Configuration lock	W	The controller can only be configured when it is unlocked.	0: Unlocked 1: Locked	0: Unlocked
P40	Auto ack alarms	W	Select whether the controller should auto acknowledge alarms. In stand alone applications it should be set to Enabled	0: Enabled 1: Disabled	1: Disabled

Service					
u01	Pc °C	R	Condensing pressure in °C. (measured with the Pc pressure transmitter)		
u03	Saux 1 °C	R	Air temp Saux temperature in °C		
u10	Lowliquid level alarm	R	Actual status of low liquid alarm	ON/OFF	
u21	Suction superheat K	R	Superheat in suction line		
u37	Common fan safety	R	Actual status of common fan safety input	ON/OFF	
u44	Sc3 Air on °C	R	Outdoor temperature in °C measured with Sc3 temperature sensor		
u48	Condenser status	R	Actual control status of condenser 0=Power up 1=Stopped 2=Manual 3=Alarm 4=Restart 5=Standby 10=Full loaded 11=Running		
u49	Cond. Cap %	R	Cut-in condenser capacity in % (of total capacity)	0-100%	
u50	Request Cond. Cap %	R	Reference for condenser capacity	0-100%	
u51	Suction status	R	Actual control status of suction group 0=Power up 1=Stopped 2=Manual 3=Alarm 4=Restart 5=Standby 10=Full loaded 11=Running		
u52	Compressor Cap %	R	Cut-in compressor capacity in % (of total capacity)	0-100%	
u53	Request Comp. Cap %	R	Reference for compressor capacity (deviations may be due to time delays)	0-100%	
u54	Sd discharge gas °C	R	Discharge gas temperature in °C		
u55	Ss suction gas °C	R	Suction gas temperature in °C		
u87	Load shed input 1	R	Actual status on Load shed input	ON/OFF	
u88	HP common safety	R	Actual status of common HP safety input for all compressors	ON/OFF	
u89	LP common safety	R	Actual status of common LP safety input for all compressors	ON/OFF	
U12	Actual setup	R	Actual selected quic setup	See documentation for quick selections	
U13	Injection ON	R	Status of the "Injection ON" function	ON/OFF	

Alarms				
A02	Low suction pressure Po		Minimum safety limit for suction pressure Po has been violated	
A11	Refrigerant A not selected		Refrigerant has not been selected	
A17	High Cond. pressure Pc		High safety limit for condensing pressure Pc has been violated	
A19	Comp. 1 safety cutout		Compressor no. 1 has been cut out on safety input	
A20	Comp. 2 safety cutout		Compressor no. 2 has been cut out on safety input	
A21	Comp. 3 safety cutout		Compressor no. 3 has been cut out on safety input	
A22	Comp. 4 safety cutout		Compressor no. 4 has been cut out on safety input	
A23	Comp. 5 safety cutout		Compressor no. 5 has been cut out on safety input	
A24	Comp. 6 safety cutout		Compressor no. 6 has been cut out on safety input	
A28	Low liquid level		Low liquid level alarm input has been activated	
A31	LP common safety		Compressors have been cut out on common LP safety input	
A32	HP common safety		Compressors have been cut out on common HP safety input	
A34	Common fan safety		Common fan safety input has been activated	
A35	Air room High temp.		The temperature measured by Saux 1 sensor is too high	
A45	Main switch		Control has been stopped via the setting "Main Switch" = OFF or via the external main switch input	
A85	High discharge temp. Sd		Safety limit for discharge temperature has been exceeded	
A86	High superheat Ss		Superheat in suction line too high	
A87	Low superheat Ss		Superheat in suction line too low	
A88	System Critical exception #1		A critical system fault has arisen – the controller needs to be exchanged	
A89	Manual DI.....		An input has been set in manual control mode via the service tool software	
A93	VSD safety cutout		VSD alarm input has been activated	
E02	Po sensor error		Pressure transmitter signal from Po defective	
	Ss sensor error		Temperature signal from Ss suction gas temp. defective	
	Sd sensor error		Temperature signal from Sd discharge gas temp. Sd defective	
	Pc sensor error		Pressure transmitter signal from Pc defective	
	Sc3 sensor error		Temperature signal from Sc3 air on condenser defective	
	Saux1 sensor error		Signal from extra temp. sensor Saux1 defective	
	System alarm exception #1		A minor system fault has arisen – power OFF/ON the controller	
	Alarm Destination disabled		When this alarm is active the alarm transmission to the alarm receiver has been disabled. When the alarm is cancelled the alarm transmission is enabled	
	Alarm Route failure		Alarms can not be send to the alarm receiver – check the communication to controller/alarm receiver	
	Alarm Router full		The internal buffer for alarm has been exceeded. This can happen if the alarm transmission to the alarm receiver is interrupted – see above.	
	Device is restarting		Restart of controller after a flash update of the software	
	Common IO Alarm		A communication problem has arisen between the controller and the extension modules – the problem should be checked immediately	
	Manual DO.....		An output has been set in manual control mode via the service tool software	
-- 1			Initiation. Display is connected to output A. (- - 2 = output B, etc.)	



---

## 5. Regulating functions

---

This section describes how the different functions work

## Suction group

### Controlling sensor

The capacity distributor can regulate according to the suction pressure P0.

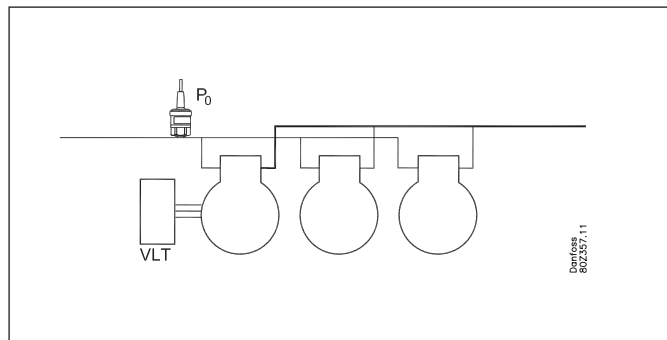

### Handling of sensor error

An error in the sensor will mean that regulation continues with 50% cut-in in daily operation and 25% cut-in at night, but for a minimum of one step.

### Reference

$P0Ref = P0 \text{ setting} + P0 \text{ optimization} + \text{night displacement}$

### P0 setting

A basic value for the suction pressure is set.

### P0 optimization

This function displaces the reference so that regulation will not take place with a lower suction pressure than required. The function cooperates with controllers on the individual refrigeration appliances and a system manager. The system manager obtains data from the individual regulations and adapts the suction pressure to the optimum energy level. The function is described in the manual for the System manager. With this function you can read which appliance is most heavily loaded at the moment as well as the displacement allowed for the suction pressure reference.

### Night displacement

The function is used to change the suction pressure reference for night time operation as an energy saving function.

With this function the reference can be displaced by up to 25 K in positive or negative direction. (When you displace to a higher suction pressure, a positive value is set).

Displacement can be activated in three ways:

- Signal on an input
- From a master gateway's override function
- Internal time schedule

*The "night displacement" function should not be used when regulation with the override function "P0-optimisation" is performed. (Here the override function will itself adapt the suction pressure to the max. permissible).*

If a short change in the suction pressure is needed (for example, up to 15 minutes in connection with defrosting) the functions can be applied. Here the P0-optimisation will not have time to compensate for the change.

### Limitation of reference

To safeguard yourself against a too high or too low regulation reference, a limitation of the reference must be set.

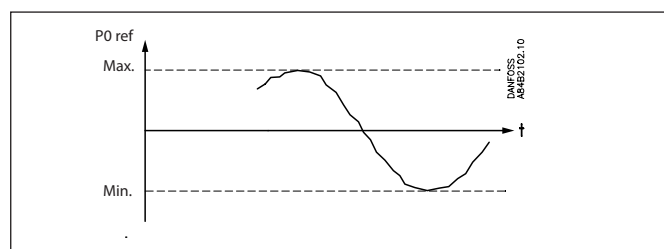

### Forced operation of the compressor capacity in the suction group

A forced operation of the capacity can be carried out which disregards the normal regulation. Depending on the selected form of forced operation, the safety functions will be cancelled.

### Forced operation via overload of requested capacity

The control is set to manual and the desired capacity is set in % of the possible compressor capacity.

### Forced operation via overload of digital outlets

The individual outputs can be set to MAN ON or MAN OFF in the software. The control function disregards this but an alarm is sent out that the outlet is being overridden.

### Forced operation via change-over switches

If the forced operation is done with the switch-over on the front of an expansion model, this is not registered by the control function and no alarm is sounded. The controller continues to run and couples with the other relays.

## Capacity control of compressors

### PI-control and control zones

AK-PC 710 can control up to 6 compressors.

One of the compressors can be equipped with speed regulation.

The calculation of the requested compressor capacity takes place on the basis of a PI control, but the set up is carried out in the same way as for a neutral zone which is divided into 5 different control zones as shown in below sketch.

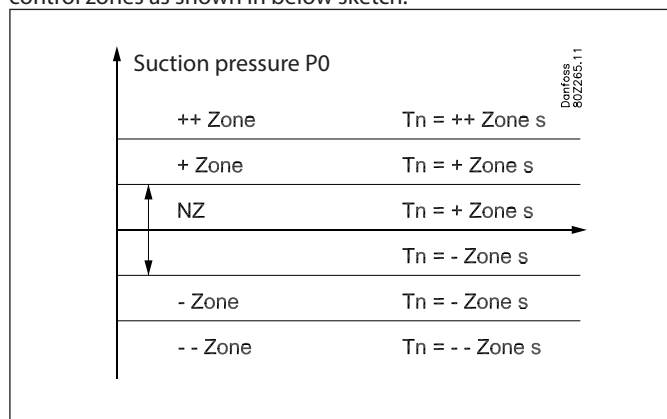

The width of some of the zones can be set via the settings "+ Zone K", "NZ K" and "- Zone K".

Furthermore it is possible to adjust zone timers which is equal to the  $T_n$  integration time for the PI controller whenever the suction pressure is in the zone in question (please see sketch above).

By setting a zone timer to a higher value will make the PI controller slower in this zone and by setting the zone timer lower will make the PI controller faster in this zone.

The amplification factor  $K_p$  is adjusted as parameter " $K_p P_0$ ". In the neutral zone the controller is only allowed to increase or decrease the capacity by means of speed control and/or switching of unloader valves.

In the other zones the controller is also allowed to increase/decrease capacity by means of starting and stopping compressors.

### Operation time first step

At start-up the refrigeration system must have time to be stable before the PI controller takes over the control. For this purpose at start-up of a plant a limitation is made of the capacity so that only the first capacity step will cutin after a set period (to be set via "runtime first step").

### Requested capacity

The readout "Requested capacity" is the output from the PI controller and it shows the actual requested compressor capacity by the PI controller. The rate of change in the requested capacity depends upon in which zone the pressure is and whether the pressure is stable or whether it is constantly changing.

The Integrator is looking at the deviation between the set point and the current pressure only and increases/reduces the requested capacity correspondingly. The amplification factor  $K_p$  on the other hand only looks at the temporary pressure changes.

In the "+ Zone" and "++ Zone" the controller will normally increase the requested capacity as the suction pressure is above the set point. But if the suction pressure is decreasing very fast the requested capacity might decrease also in these zones.

In the "- Zone" and "-- Zone" the controller will normally decrease the requested capacity as the suction pressure is below the set point. But if the suction pressure is increasing very fast the requested capacity might increase also in these zones.

### Change capacity

The controller will cutin or cutout capacity based on these basic rules:

#### Increase capacity:

The capacity distributor will start extra compressor capacity as soon as the requested capacity has increased to a value, which allows the next compressor step to start. Referring to below example - a compressor step is added as soon as there is "Room" for this compressor step below the requested capacity curve.

#### Decrease capacity:

The capacity distributor will stop compressor capacity as soon as the requested capacity has decreased to a value, which allows the next compressor to stop. Referring to below example - a compressor step is stopped as soon as there is no more "Room" for this compressor step above the requested capacity curve.

#### Example:

4 compressor of equal size - The capacity curve will look like this

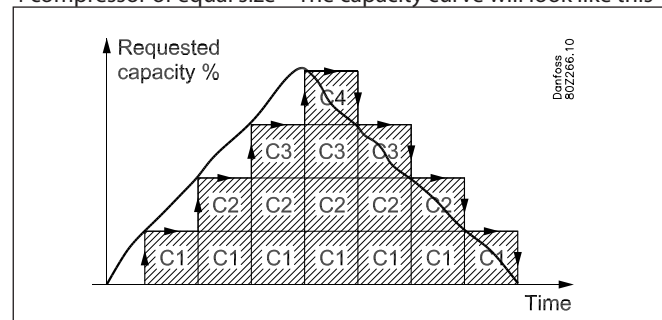

#### Cut-out of the last compressor stage:

Normally, the last compressor step will only be cut-out when the required capacity is 0% and the suction pressure is at "-Zone" or in "-Zone"

### Pump down function:

To avoid too many compressor starts/stops with low load, it is possible to define a pump down function for the last compressor.

If the pump down function is used, the compressors will be cut-out when the actual suction pressure is down to the configured pump down limit.

Note that the configured pump down limit should be set higher than the configured safety limit for low suction pressure "Min Po".

### Dynamic extension of the neutral zone

All refrigeration systems have a dynamic response time when starting and stopping compressors. In order to avoid that the controller will start/stop compressors shortly after each other, the controller must be allowed some extra time after a compressor start/stop to see the effect of the previous change in running capacity.

In order to achieve this, a dynamic extension of the zones is added.

The zones will be extended for a short period of time when starting or stopping a compressor. By extending the zones the PI controller will be slowed down in a short period of time after a change in compressor capacity.

The amplitude of the zone extension depends upon the actual running compressor capacity and upon the size of the compressor step which is being stopped/started. The amplitude of the zone extension is bigger when running with low compressor capacity and when starting/stopping big compressor capacity steps. However the time period for the zone extension is constant – after a fixed time period after a compressor start/stop the dynamic zone extension is reduced to 0.

Via the “Minimize number of couplings” setting it is possible to influence how big the amplitude of the dynamic zone extension should be in order to minimize the cycling of the compressors. By setting “Minimize number of couplings” to “No reduction” there will be no dynamic extension of the zones. By setting “Minimize number of couplings” to “Low”, “Medium” or “High” the dynamic extension of the zones will be activated. The amplitude of the zone extension will be highest when “Minimize number of couplings” is set to “High”. Please refer to the next sketch which shows an example with 6 compressor steps and with “Minimize number of couplings” set to “High”. Please also note that the dynamic extension of the zones is highest at low compressor capacity.

“Minimize number of couplings” = “High”

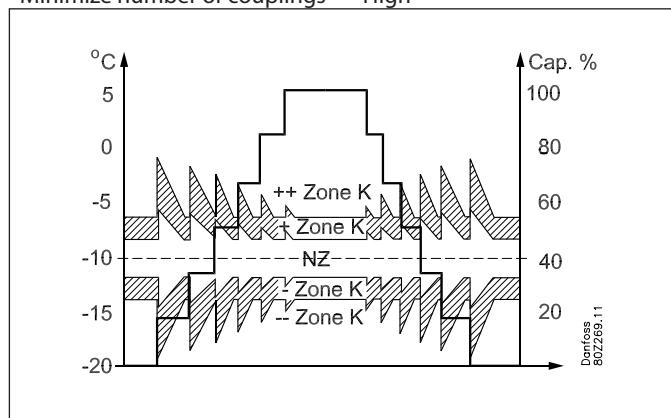

### Actual band

As a consequence of the dynamic extension of the zones the suction pressure might very well change zone for a period of time when the controller is starting/stopping a compressor i.e. the suction pressure is in the +Zone, but as the controller starts a compressor, the zones are extended for a period of time and during this period of time the suction pressure will be in the NZ.

In the controller the readout “Actual band” will show in which zone the PI controller is operating – this includes the extension of the zones.

## Capacity distribution methods

The capacity distributor can work based on 3 distribution principles.

### Coupling pattern – sequential operation:

The compressors are cut in and cut-out following the “First in, Last out” (FILO) principle in accordance with the sequence defined in the set-up.

Any speed-regulated compressors are used to close capacity gaps.

#### Timer restrictions

If a compressor is prevented from starting because it “hangs” on the re-start timer, this step is not replaced by another compressor but the step switch waits until the timer has lapsed.

#### Safety cutout

If on the other hand there is a safety switch on this compressor, this is excluded and the step switch immediately selects the following step in the sequence.

### Coupling pattern – Cyclical operation:

This principle is used if all compressors are of the same type and size.

The compressor cuts-in and cuts-out in accordance with the “First In First Out” principle (FIFO) to equalise operating hours between the compressors.

Speed-regulated compressors will always be cut in first, and the variable capacity is used to fill capacity gaps between the subsequent steps.

#### Timer restrictions and safety cut outs

If a compressor is prevented from starting because it is “hanging” on the restart timer or is safety cut out, this step is replaced by another compressor.

### Operating time equalisation

The operating hour equalizing is carried out between compressors of the same type with the same total capacity.

- At the different startups the compressor with the lowest number of operating hours will be started first.
- At the different stops the compressor with the highest number of operating hours will be stopped first.
- For compressors with several steps, the operating time equalizing is carried out between the compressors’ main steps.

### Coupling pattern – Best fit operation

This principle is used if the compressors are of different sizes.

The capacity distributor will cut-in or cut-out the compressor capacity in order to ensure the least possible capacity jump. Speed-regulated compressors will always be cut in first, and the variable capacity will be used to fill capacity gaps between the subsequent steps.

#### Timer restrictions and safety cut outs

If a compressor is prevented from starting because it is “hanging” on the restart timer or is safety-cut out, this step is replaced by another compressor or another combination.

#### Minimum capacity change

To prevent the capacity distributor from selecting a new compressor combination (cut-out and cut-in compressors) due to a small change in capacity requirements, it is possible to set a minimum change in capacity requirement that will operate before the capacity distributor changes to a new compressor combination.



## Power pack types – compressor combinations

The controller is able to control power packs with up to 6 compressors of various types:

- One speed controlled compressor
- Single step compressors – piston or scroll

The chart below shows the compressor combination which the controller is capable of controlling. The chart also shows which coupling pattern can be set for the individual compressor combinations.

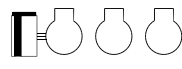
Combination	Description	Coupling pattern			Application
		Sequence	Cyclical	Best fit	
	One-step compressors. *1	x	x	x	21-40
	A speed-regulated compressor combined with one-step compressors. *1 and *2	x	x	x	1-20

\*1) For a cyclical coupling pattern, the one-step compressors must be the same size.

\*2) Speed-regulated compressors can have different sizes in relation to subsequent compressors.

In appendix A there is a more detailed description of the coupling patterns for the individual compressor applications with associated examples.

The following is a description of some general rules for handling speed-regulated compressor.

### Speed control compressors:

The controller is able to use speed control on the leading compressor in different compressor combinations. The variable part of the speed controlled compressor is used to fill in capacity gaps of the following compressor steps.

General regarding handling:

One of the defined capacity steps for the compressor regulation may be connected to a speed control unit that may be a frequency converter type VLT, for example.

An output is connected to the frequency converter's ON/OFF input and at the same time an analog output "AO" is connected to the frequency converter's analog input. The ON/OFF signal will start and stop the frequency converter and the analog signal will indicate the speed. It is only the compressor defined as compressor 1 that can be speed controlled.

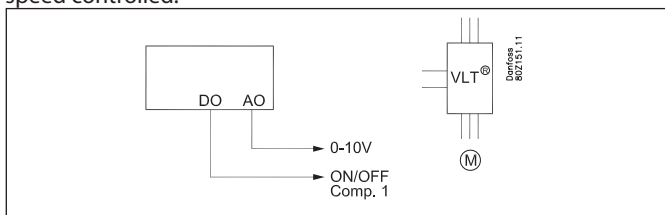

When the step is in operation it will consist of a fixed capacity and a variable capacity. The fixed capacity will be the one that corresponding to the mentioned min. speed and the variable one will lie between the min. and max. speed. To obtain the best regulation the variable capacity must be bigger than the subsequent capacity steps it has to cover during the regulation. If there are major short-term variations in the plant's capacity requirement it will increase the demand for variable capacity.

This is how you cut the step in and out:

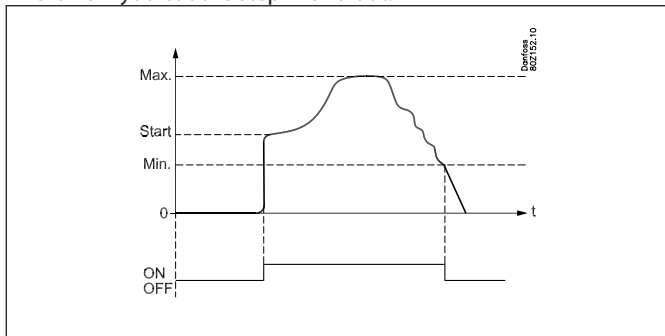

### Cutin

The speed-controlled compressor will always be the first to start and the last to stop. The frequency converter will be started when a capacity requirement corresponding to the mentioned "Start speed" arises (the relay output changes to ON and the analog output is supplied with a voltage corresponding to this speed). It is now up to the frequency converter to bring the speed up to "Start speed".

The capacity step will now be cut in and the required capacity determined by the controller.

The start speed always ought to be set so high that a fast lubrication of the compressor is obtained during the start.

### Controlling – increasing capacity

If the need for capacity becomes larger than "Max. Speed" then the subsequent compressor step will be cut-in. At the same time, the speed on the capacity step will be reduced so the capacity is reduced with a size that corresponds to exactly the cut-in compressor step. Thereby a completely "frictionless" transition is achieved without capacity holes (refer also to sketch).

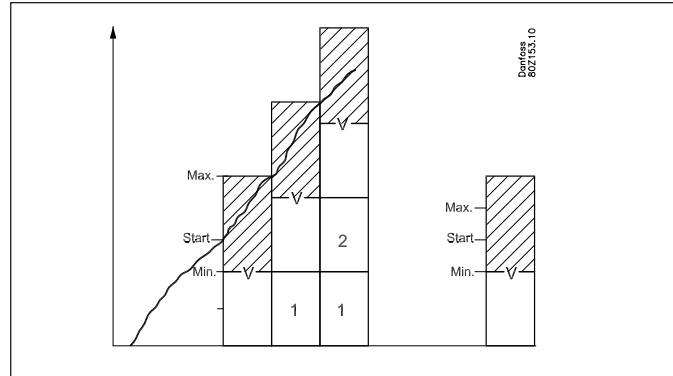

### Controlling – decreasing capacity

If the capacity requirement becomes less than "Min. speed" then the subsequent compressor step will be cut-out. At the same time, the speed on the capacity step is increased so the capacity is increased with a size that corresponds to exactly the cut-out compressor step.

### Cut-out

The capacity step will be cut-out when the compressor has reached "Min. Speed" and the requested capacity has dropped to 1%.

### Timer restriction on speed controlled compressor

If a speed controlled compressor is not allowed to start due to a timer restriction, no other compressor is allowed to start. When the timer restriction has expired the speed controlled compressor will start.

### Safety cutout on speed controlled compressor

If the speed controlled compressor is cutout on safety other compressors are allowed to start. As soon as the speed controlled compressor is ready to start it will be the first compressor to start.

As mentioned before the variable part of the speed capacity should be bigger than the capacity of the following compressor steps in order to achieve a capacity curve without "holes". In order to illustrate how the speed control will react at different pack combinations a couple of examples will be given here:

a) *Variable capacity bigger than following compressor steps:*  
When the variable part of the speed controlled compressor is bigger than the following compressors there will be no "holes" in the capacity curve.

Example:

- 1 speed controlled compressor with a nominal capacity at 50Hz of 10kW - Variable speed range 30 – 90Hz
- 2 one step compressors of 10 kW

Fixed capacity = 30 HZ / 50 HZ x 10 kW = 6 kW

Variable capacity = 60 HZ / 50Hz x 10 kW = 12 kW

The capacity curve will look like this:

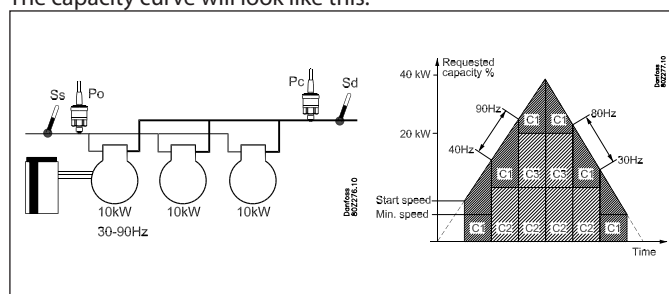

As the variable part of the speed controlled compressor is bigger than the following compressor steps, the capacity curve will be without holes.

- 1) The speed controlled compressor will be cut in when the requested capacity has reached the start speed capacity.
- 2) The speed controlled compressor will increase speed until it reaches max speed at a capacity of 18 kW.
- 3) The one step compressor C2 of 10 kW is cut in and the speed on C1 is reduced too so that it corresponds to 8kW (40Hz)
- 4) The speed controlled compressor will increase speed until the total capacity reaches 28 kW at max speed
- 5) The one step compressor C3 of 10kW is cut in and the speed on C1 is reduced too so that it corresponds to 8kW (40Hz)
- 6) The speed controlled compressor will increase speed until the total capacity reaches 38 kW at max speed
- 7) When reducing capacity the one step compressors will be cut out when the speed on C1 is at minimum

b) *Variable part smaller than following compressor steps:*  
If the variable part of the speed controlled compressor is smaller than the following compressors there will be "holes" in the capacity curve.

Example:

- 1 speed controlled compressor with a nominal capacity at 50Hz of 20kW - Variable speed range 25 – 50Hz
  - 2 one step compressors of 20 kW
- Fixed capacity = 25 HZ / 50 HZ x 20 kW = 10 kW
- Variable capacity = 25 HZ / 50Hz x 20 kW = 10 kW

The capacity curve will look like this:

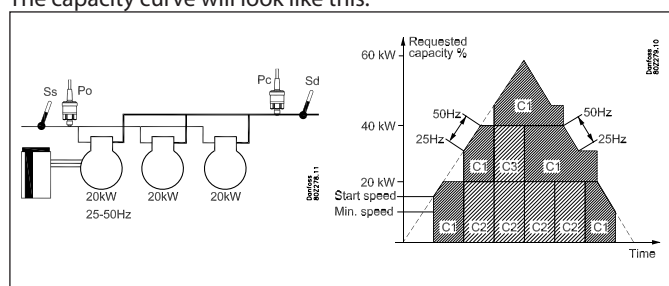

As the variable part of the speed controlled compressor is smaller than the following compressor steps the capacity curve will have some holes that can not be filled out by the variable capacity.

- 1) The speed controlled compressor will be cut in when the requested capacity has reached the start speed capacity.
- 2) The speed controlled compressor will increase speed until it reaches max speed at a capacity of 20 kW.
- 3) The speed controlled compressor will stay at max speed until the requested capacity has increased to 30 kW.
- 4) The one step compressor C2 of 20 kW is cut in and the speed on C1 is reduced to min. so that it corresponds to 10kW (25Hz). Total capacity = 30 kW.
- 5) The speed controlled compressor will increase speed until the total capacity reaches 40 kW at max speed
- 6) The speed controlled compressor will stay at max speed until the requested capacity has increased to 50 kW.
- 7) The one step compressor C3 of 20kW is cut in and the speed on C1 is reduced to min. so that it corresponds to 10kW (25Hz). Total capacity = 50 kW
- 8) The speed controlled compressor will increase speed until the total capacity reaches 60 kW at max speed
- 9) When reducing capacity the one step compressors will be cut out when the speed on C1 is at minimum speed.

## Compressor timers

### Time delays for cutins and cutouts

To protect the compressor against frequent restarts three time delays can be put in.

- A minimum time to run from a compressor's startup and until it may be restarted.
- A minimum time (ON-time) for the compressor to operate before it may be stopped again.
- A minimum OFF time to run from a compressor stops and until it may be restarted

When unloaders are cut in and out, the time delays will not be used.

### Timer

The operating time of a compressor motor is registered continuously. You can read out:

- operating time for the previous 24-hour period
- total operating time since the timer was last set to zero-set.

### Coupling counter

The number of relay cutins and cutouts is registered continuously. The number of starts can be read out here:

- Number during the previous 24-hour period
- Total number since the counter was last set to zero-set.

## Load shedding

On some installations there is the desire to limit the cut-in compressor capacity so that one can limit the total electrical load in the store for periods.

There is 1 digital inlet available for this purpose.

For digital inlet a limit value is attached for the maximum allowable cut-in compressor capacity.

When an inlet is activated, the maximum allowable compressor capacity is limited to the set limit. This means that if the actual compressor capacity upon activation of the digital inlet is higher than this limit, then so much compressor capacity is cut-out that it will then be on or under the set maximum limit value for this digital inlet.

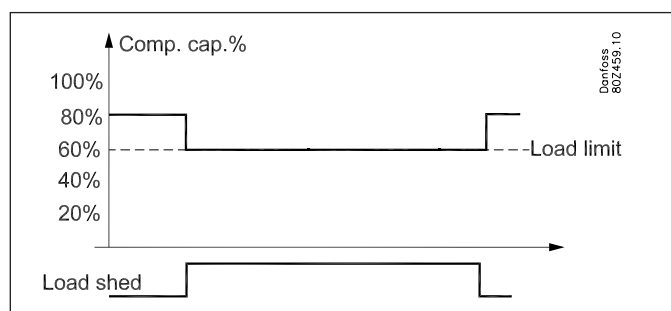

### Overriding of load shedding:

To avoid load shedding leading to temperature problems for the chilled products, an overriding function is fitted.

A overriding limit is set for the suction pressure as well as a delay time for the digital inlet.

If the suction pressure during load shedding exceeds the set overriding limit and delay times expire then load shedding overrides the signals so that the compressor capacity can be increased until the suction pressure is again under the normal reference value. The load shedding can then be activated again.

### Alarm:

When load shedding inlet is activated, an alarm will be activated to inform that the normal control has been bypassed. This alarm can however be suppressed if so desired.

## Injection ON

The electronic expansion valves in the refrigeration appliances must be closed when all the compressors are stopped and a restart is blocked. In this way the evaporators will not be filled with liquid which is subsequently passed on to a compressor when regulation is restarted.

The function can be attained via data communication.

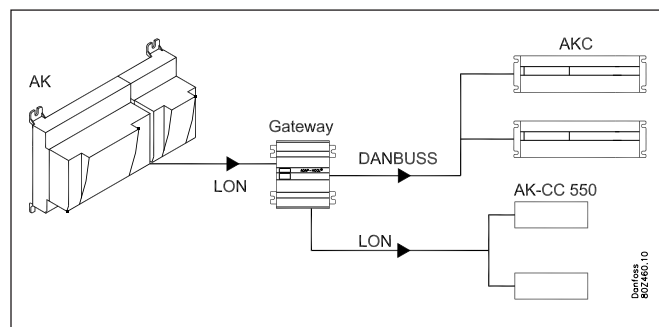

The function is described based on the sequence of events below:

- T1) The last compressor is cut-out
- T2) The suction pressure has increased to a value corresponding to  $P_o \text{ Ref} + \text{NZ} + \text{"+Zone K"}$  but no compressor can start due to re-start timers or safety cut-out
- T3) The time delay "Injection OFF delay" elapses and the injection valves are forced to close via network signal.
- T4) The first compressor is now ready to start. The forced closure signal via the network is now cancelled.
- T5) The time delay "Comp. Start delay" expires and the first compressor being allowed to start.

The reason why the forced closure signal via the network is cancelled before the first compressor starts, is that it will take some time to distribute the signal to all appliance controllers via the network.

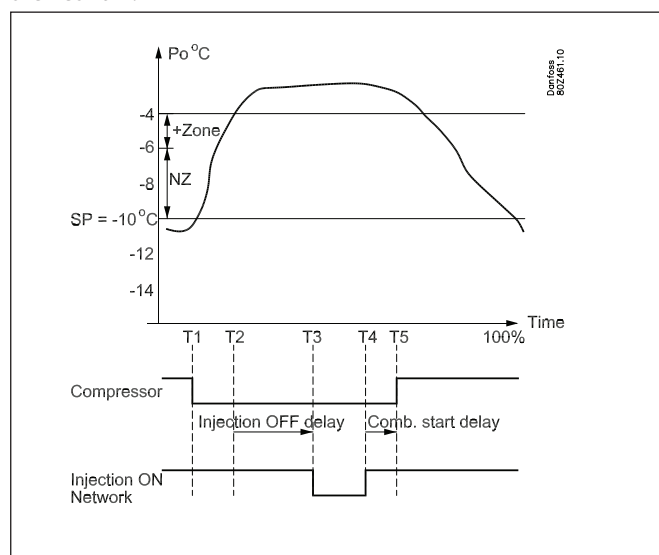

## Safety functions

### Signal from the compressor's safety controls

The controller can monitor the status of each compressor's safety circuit. The signal is taken directly from the safety circuit and connected to an input.

(The safety circuit must stop the compressor without involving the controller).

If the safety circuit is cut out the controller will cut out the relay for the compressor in question and give an alarm. Regulation will continue with the other compressors.

### Common safety circuit

A common safety signal can also be received from the whole suction group. All compressors will be cut out when the safety signal cuts out.

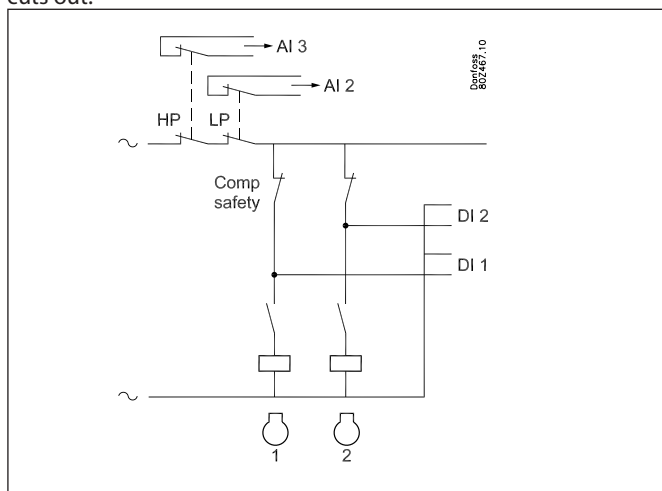

### Time delays with safety cut-out:

In connection with safety monitoring of a compressor it is possible to define two delay times:

- Cut-out delay time: Delay time from alarm signal from the safety circuit until the compressor outlet cuts out (note that the delay time is common to all security inlets)
- Safety re-start time: The minimum time a compressor must be OK after a safety cut-out until it may start again.

### Monitoring of superheat

This function is an alarm function which continuously receives measured data from suction pressure P0 and suction gas Ss. If superheat is registered which is lower or higher than the set limit values, an alarm will be given when the time delay has passed.

### Monitoring of max. discharge gas temperature (Sd)

The function gradually cuts out compressor steps if the discharge temperature becomes higher than permitted. The cutout limit can be defined in the range from 0 to +150°C.

The function is started at a value that is 10 K below the set value. At this point the entire condenser capacity is cut in at the same time as 33% of the compressor capacity is cut out (but minimum one step). This is repeated every 30 seconds. The alarm function is activated.

If the temperature rises to the set limit value all compressor steps are immediately cut out.

The alarm is cancelled and renewed cutin of compressor steps is permitted when the following conditions are met:

- the temperature has dropped to 10 K below the limit value
- the time delay prior to restart has been passed. (see later)

Normal condenser control is permitted again when the temperature has dropped to 10 K below the limit value.

### Monitoring of min. suction pressure (P0)

The function promptly cuts out all compressor steps if the suction pressure becomes lower than the permitted value.

The cutout limit can be defined in the range from -120 to +30°C. The suction is measured with pressure transmitter P0.

At cutout the the alarm function is activated:

The alarm is cancelled and renewed cutin of compressor steps is permitted when the following conditions are met:

- the pressure (temperature) is above the cutout limit
- the time delay has elapsed (see later).

### Monitoring of max. condensing pressure (Pc)

The function cuts in all condenser steps and cuts out compressor steps one by one if the condensing pressure becomes higher than permitted. The cutout limit can be defined in the range from -30 to +100°C.

The condensing pressure is measured with pressure transmitter Pc.

The function takes effect at a value which is 3 K below the set value. At this time the entire condenser capacity is cut in at the same time as 33% of the compressor capacity is cut out (but min. one step). This is repeated every 30 seconds. The alarm function is activated.

If the temperature (pressure) rises to the set limit value, the following will happen:

- all compressor steps will immediately be cut out
- the condenser capacity will remain cut in

The alarm will be cancelled and renewed cutin of compressor steps is permitted when the following conditions are met:

- the temperature (pressure) falls to 3 K below the limit value
- the time delay for restart has been passed.

### Delay of Pc max alarms

It is possible to delay the "Pc max alarm" message.

The controller will still disconnect the compressors, but the sending of the alarm itself is delayed.

### Time delay

There is a joint time delay for "Monitoring of max. discharge gas temperature" and "Min. suction pressure" and monitoring of max condensing pressure Pc.

### Alarm for too high suction pressure

An alarm limit can be set which will become effective when the suction pressure becomes too high. An alarm will be transmitted when the set time delay has been passed. The regulation continues unchanged.

# Condenser

Capacity control of the condenser can be accomplished via step regulation or speed control of the fans.

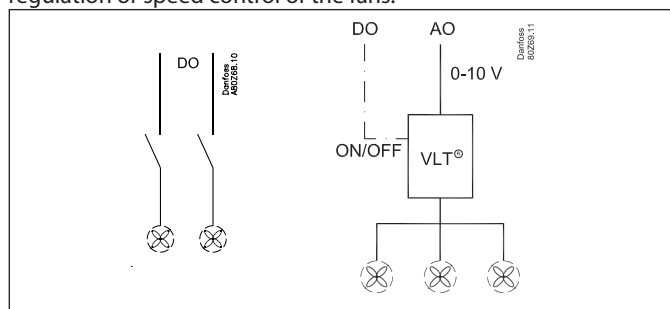

- **Step regulation**  
The controller can control up to 6 condenser steps that are cut in and out sequentially.
- **Speed control**  
The analog output voltage is connected to a speed control. All fans will now be controlled from 0 to max. capacity. If an ON/OFF signal is required it can be obtained from fan 1 relay. Regulation can be carried out based on one of the following two principles:
  - all fans operate at the same speed
  - Only the necessary number of fans is cut in.

## Capacity control of condenser

The cut-in condenser capacity is controlled by the condenser pressure's actual value and depends on whether the pressure is rising or falling. Regulation is performed by a PI controller which may however be changed into a P controller if the design of the plant necessitates this.

### PI regulation

The controller cuts in capacity in such a way that the deviation between the actual condensing pressure and the reference value becomes as small as possible.

### P regulation

The controller cuts in capacity that depends on the deviation between the actual condensing pressure and the reference value. The proportional band  $X_p$  indicates the deviation at 100% condenser capacity.

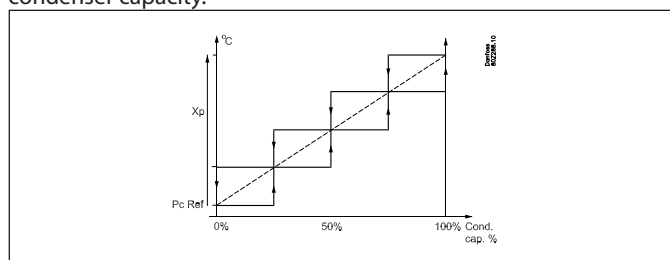

### Capacity curve

On air-cooled condensers, the first capacity step will always give comparatively more capacity than the subsequent capacity steps. The increase in capacity produced by each extra step decreases gradually as more and more steps are cut in.

This means that the capacity controller requires more amplification at high capacities than at low capacities. Consequently, the capacity controller for condenser regulation functions with an arc-shaped capacity curve so that amplification is optimal at both high and low capacities.

On some units, compensation is already made for the "problem" described above, by binary connection of the condenser fans: i.e. a few fans are connected at low capacity and many fans at high capacity, for example 1-2-4-8 etc. In this case, the non-linear amplification is already compensated for, and there is no need for an arc-shaped capacity curve.

It is therefore possible to choose on the controller whether you require an arc-shaped or a linear capacity curve to manage the condenser capacity.

Capacity curve = Linear / Power

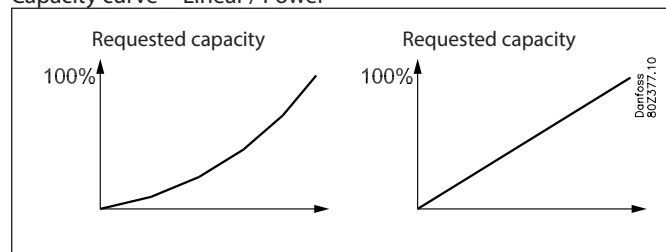

Capacity curve = Power

Capacity curve = Linear

### Regulating sensor

The capacity distributor regulates from the condenser pressure PC.

Handling sensor errors:

An error in the signal will result in a cut-in of 100% condenser capacity, but the compressor regulation will remain normal.

## Reference for condensing pressure

The reference for the regulation can be defined in two ways. Either as a fixed reference or as a reference that varies according to the outdoor temperature.

### Fixed reference

The reference for the condensing pressure is set in °C.

### Floating reference

This function allows the condensing pressure's reference value to vary according to the outdoor temperature within a defined area. By combining floating condensing pressure with electronic expansion valves a lot of energy saving can be achieved. The electronic expansion valves enables the controller to decrease the condensing pressure according to outdoor temperature and thereby reduce energy consumption by around 2% for each degree the temperature can be decreased.

### PI regulation

The reference is based on:

- the outdoor temperature measured with Sc3 sensor
- The minimum temperature difference between the air temperature and the condensing temperature at 0% compressor capacity.
- the condenser's dimensioned temperature difference between the air temperature and the condensing temperature at 100% compressor capacity (Dim tmK)
- how large a part of the compressor capacity has been cut in.

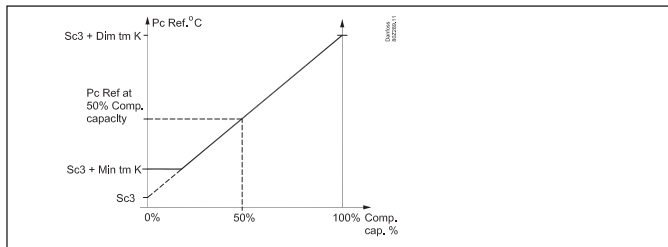

The minimum temperature difference (min tm) at low load should be set at approximately 6 K as this will eliminate the risk that all fans will be running when no compressors are running. Set the dimensioned difference (dim tm) at max. load (e.g. 15 K).

The controller will now contribute with a value to the reference which depends on how large a part of the compressor capacity has been cut in.

### P-regulation

With P regulation the reference will be three degrees above the measured outdoor temperature. The proportional band  $X_p$  indicates the deviation with 100% condenser capacity.

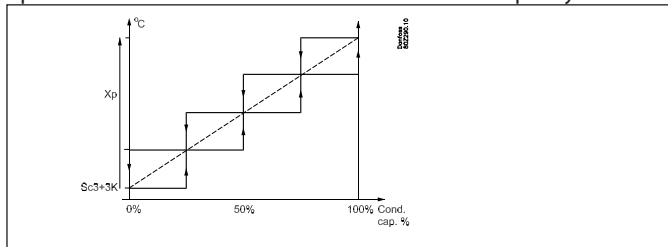

### Limitation of the reference

To safeguard yourself against a too high or too low regulation reference, a limitation of the reference must be set.

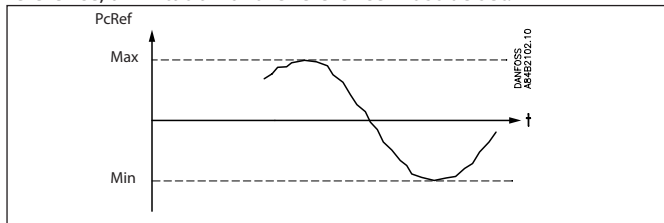

### Forced operation of condenser capacity

Forced operation of the capacity can be arranged where the normal regulation is ignored.

The safety functions are cancelled during forced operation.

Forced operation via setting

The regulation is set to Manual.

The capacity is set in percent of the regulated capacity.

Forced operation of relays

If the forced operation is carried out with the switches at the front of an extension module, the safety function will register any exceeding of values and transmit alarms, if required, but the controller cannot cut the relays in or out in this situation.



## Capacity distribution

### Step regulation

Cut-ins and cutouts are carried out sequentially. The last cut-in unit will be cut out first.

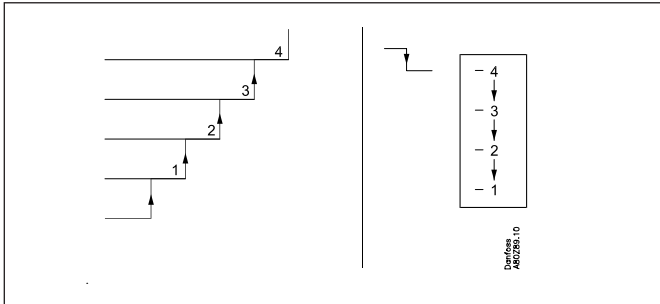

### Speed regulation

When an analog output is used the fans can be speed regulated, e.g. with a frequency converter type VLT.

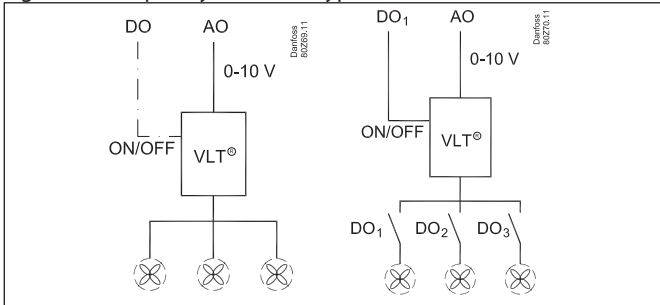

### Joint speed regulation

The analog output voltage is connected to the speed regulation. All fans will now be regulated from 0 to max. capacity. If an ON/OFF signal is required for the frequency converter, so that the fans can be stopped completely, relay output "Fan 1" is used.

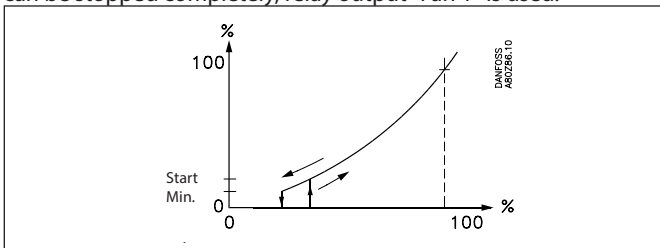

The controller starts the frequency converter when the capacity requirement corresponds to the set starting speed. The controller stops the frequency converter when the capacity requirement becomes lower than the set minimum speed.

### Speed regulation + step regulation

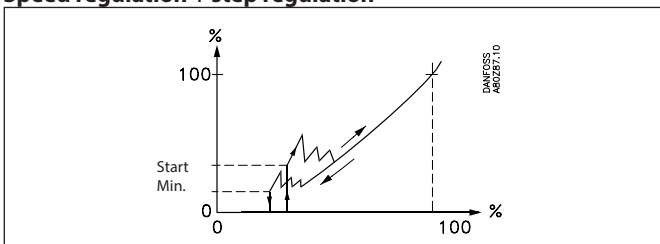

The controller starts the frequency converter and the first fan

when the capacity requirement corresponds to the set starting speed.

The controller cuts in several fans step by step as the capacity requirement grows and then adapts the speed to the new situation.

The controller cuts out fans when the capacity requirement becomes lower than the set minimum speed.

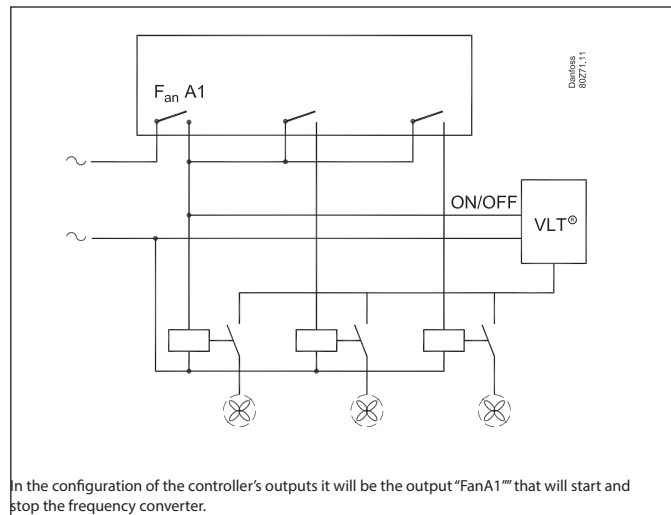

In the configuration of the controller's outputs it will be the output "FanA1" that will start and stop the frequency converter.

## Condenser couplings

### Coupling of condenser steps

There are no time delays in connection with cutin and cutout of condenser steps beyond the time delay inherent in the PI/P-regulation.

### Timer

The operating time of a fan motor is registered continuously. You can read out:

- operating time for the previous 24-hour period
- total operating time since the timer was last set to zero-set.

### Coupling counter

The number of couplings is registered continuously. Here the number of starts can be read out:

- number during the previous 24-hour period
- total number since the counter was last set to zero-set.

### Motion af ventilatorer

De sidste ventilatorer bliver næppe aktiveret i vinterhalvåret.

For at sikre, at ventilatorerne bliver motioneret, vil der for hver 24 timer, blive kontrolleret om alle relæer har været i drift.

De relæer, der ikke har været i drift, vil nu blive aktiveret i et halvt minut, men dog med en pause på en time imellem de enkelte relæer.

En hastighedstyring køres op til "Start speed".



## Safety functions for condenser

### Signal from fan safety controls

The controller can receive signals on the status on a common safety circuit.

The signal is obtained directly from the safety circuit and connected to a "DI7" input.

If the safety circuit is cut out the controller will give alarm.

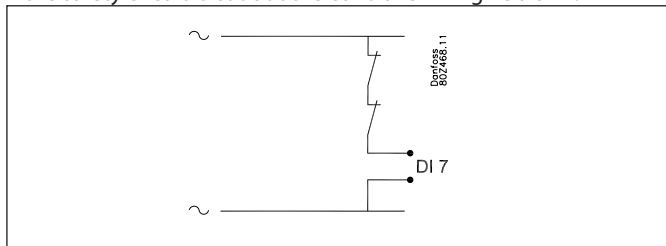

## Separate monitoring functions

### Liquid level alarm

An input can be used for monitoring an external signal.

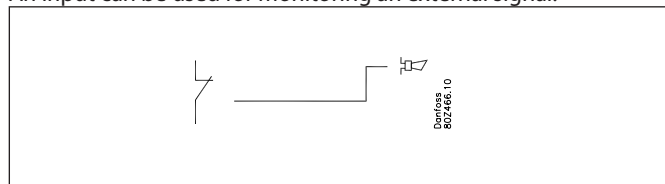

If the signal is interrupted, an alarm will be triggered.  
A time delay can be set for the alarm.

### Room temperature alarm

The function may be used for alarm monitoring of the temperature

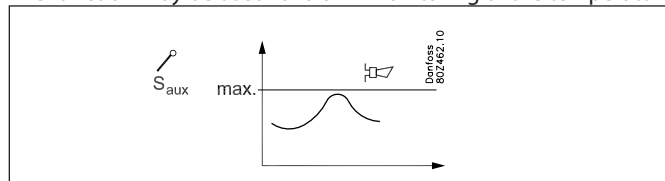

Alarm limits can be set for high temperature.  
Time delays can be set for the alarm,

### VSD safety alarm

An input can be used for monitoring frequency converter.

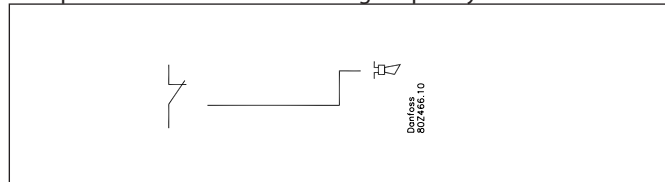

If the signal is interrupted, an alarm will be triggered.  
A time delay can be set for the alarm.

## Miscellaneous

### Main switch

The main switch is used to stop and start the controlling function.

The switch-over has 2 positions:

- Normal controlling state (Setting = ON)
- Control stopped. (Setting = OFF)

In addition, there is also an input which is used as an external main switch.

If the switch-over or the external main switch is set at OFF, all the control's functions are inactive and an alarm is generated to draw attention to this – all other alarms cease.

### Refrigerant

Before regulation can be commenced, the refrigerant must be defined.

You can select one of the following refrigerants:

1 R12	11 R114	21 R407A	31 R422A
2 R22	12 R142b	22 R407B	32 R413A
3 R134a	13 Brugerdefineret	23 R410A	33 R422D
4 R502	14 R32	24 R170	34 R427A
5 R717	15 R227	25 R290	35 R438A
6 R13	16 R401A	26 R600	36 R513A
7 R13b1	17 R507	27 R600a	37 R407F
8 R23	18 R402A	28 R744	
9 R500	19 R404A	29 R1270	
10 R503	20 R407C	30 R417A	

The refrigerant can only be changed if the "Main switch" is set at "stopped control" and the configuration lock is open.

Warning: Incorrect selection of refrigerant can cause damage to the compressor.

### Sensor failure

If lack of signal from one of the connected temperature sensors or pressure transmitters is registered an alarm will be given.

- When there is a P0 error regulation will continue with 50% cut-in capacity during day operation and 25% cut-in capacity during night operation – but minimum one step.
- When there is a Pc error 100% condenser capacity will be cut in, but the compressor regulation will remain normal.
- When there is an error on the Sd sensor the safety monitoring of the discharge gas temperature will be discontinued.
- When there is an error on the Ss sensor the monitoring of the superheat on the suction line will be discontinued.
- When there is an error on the outdoor temperature sensor Sc3 regulation with variable condensing pressure reference cannot be carried out. Instead you use the PC ref. min. value as reference.

Note: An incorrect sensor must be in order for 10 minutes before the sensor alarm deactivates.

### Sensor calibration:

The input signal from all connected sensors can be corrected. A correction will only be necessary if the sensor cable is long and has a small cross-sectional area. All displays and functions will reflect the corrected value.

### Clock function

The controller contains a clock function.

The clock function is used only to change between day/night. The year, month, date, hour and minutes must be set.

Note: If the controller is not equipped with a RTC module (AK-OB 101A) the clock must be reset after each mains voltage outage.

If the controller is connected to an installation with an AKA-gateway or an AK system manager, this will automatically reset the clock function.

### Alarms and messages

In connection with the controller's functions, there are a number of alarms and messages that become visible in cases of fault or erroneous operation.

### Alarm history (service tool only)

The controller contains an alarm history (log) that contains all active alarms as well as the last 40 historical alarms. In the alarm history you can see when the alarm began and when it stopped. In addition, one can see the priority of each alarm as well as when the alarm has been acknowledged and by which user.

### Alarm priority:

Differentiation is made between important and not-so-important information. The importance – or priority – is set for some alarms whilst others can be changed voluntarily (this change can only be done with attachment of AK-ST service tool or AKM software).

The setting decides which sorting / action must be carried out when an alarm is sounded.

- "High" is the most important
- "Log only" is the lowest
- "Interrupted" results in no action

### Alarm relay

There is an alarm output on the controller as a local alarm indication.

The relationship between alarm priority and action appears in the schedule below.

Setting	Log	Alarm relay	Send Network	AKM destination
High	X	X	X	1
Medium	X		X	2
Low	X		X	3
Log only	X			4
Interrupted				

#### Alarm acknowledgement

If the controller is connected to a network with an AKA gateway or an AK system manager as alarm receiver, these will automatically acknowledge the alarms that are sent to them.

If the controller is used as stand alone without a network connection, the controller can acknowledge the alarms automatically. Then the alarms will automatically go off, when the cause of the alarm disappears.

(Set "Auto act. alarm" to "Enabled" / P40 to 0.)

#### Alarm LED

The alarm LED on the front of the controller indicates the controller's alarm status.

Blinking: There is an active alarm or an unacknowledged alarm.

Fixed light: There is an active alarm that has been acknowledged.

Switched off: There are no active alarms and no unacknowledged alarms.

#### IO Status and manual

The function is used in connection with installation, servicing and fault-finding on the equipment.

With the help of the function, the connected outputs are controlled.

#### Measurements

The status of all inlets and outlets can be read and controlled here.

#### Forced operation (Service tool only)

One can carry out an override of all outlets here to control whether these are correctly attached.

Note: There is no monitoring when the outlets are overridden.

#### Logging/registration of parameters

As a tool for documentation and fault-finding, the controller provides the possibility of logging of parameter data in the internal memory.

Via AK-ST 500 service tool software one can:

- Select up to 10 parameter values the controller will continuously register
- State how often they must be registered

The controller has a limited memory but as a rule of thumb, the 10 parameters can be saved, which are registered every 10 minutes for 2 days.

Via AK-ST 500 one can subsequently read the historical values in the form of graph presentations.

The log only works when the clock has been set.

#### Forced operation via network

The controller contains settings that can be operated from the gateway's forced operation function via data communication.

When the forced operation function asks about one change, all the connected controllers on this network will be set simultaneously.

There are the following options:

- Change to night operation
- Forced closure of injection valves (Injection ON)
- Optimising of suction pressure (Po)

#### Operating AKM / Service tool / Display

The setup of the controller itself can be carried out via AK-ST 500 service tool software, AKM-software, graphic display AK-MMI or with display EKA 164.

Note: AKM system software does not provide access to all configuration settings of the controller. The settings/read-outs that may be made appear in the AKM menu operation (see also Literature overview).

#### Authorisation / Passwords

The controller can be operated with System software type AKM with service tool software AK-ST 500 and display.

All methods of operation provide the possibility for access to several levels according to the user's insight into the various functions.

#### System software type AKM:

The various users are defined here with initials and key word. Access is then opened to exactly the functions that the user may operate.

The operation is described in the AKM manual.

#### Service tool software AK-ST 500:

The operation is described in fitters on site guide.

When a user is created, the following must be stated:

- State a user name
- State a password
- Select user level
- Select units – either US (e.g. °F and PSI) or Danfoss SI (°C and Bar)
- Select language

Access is given to four user levels.

- 1) DFLT – Default user – Access without use of password  
See daily settings and read-outs.
- 2) Daily – Daily user  
Set selected functions and carry out acknowledgement of alarms.
- 3) SERV – Service user  
All settings in the menu system except for creation of new users
- 4) SUPV – Supervisor user  
All settings including the creation of new users.

#### Display

An access code can be defined in one of the menus. You can access all function when the code has been entered.

### Display of suction pressure and condensing pressure

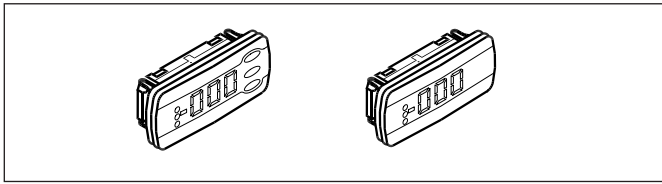

One or two separate displays can be connected to the controller. Connection is accomplished by means of wires with plug connections. The display may be placed in a control box front, for example. When a display with control buttons is chosen, a simple operation via a menu system can be performed in addition to the display of suction pressure and condensing pressure. See earlier in the manual.

When a display is connected, it will show the value for what is indicated in "Read out".

If you want to see one of the values for what is given under "function" you should use the buttons in the following way:

1. Press on the upper button until a parameter is shown
2. Press on the upper or lower button and find the parameter you want to read
3. Press on the middle button until the value of the parameter is displayed.

After a short time, the display will return automatically to the "Read out display".

If LED indication of compressor operation, fan operation and various functions is required, display type EKA 166 can be fitted.

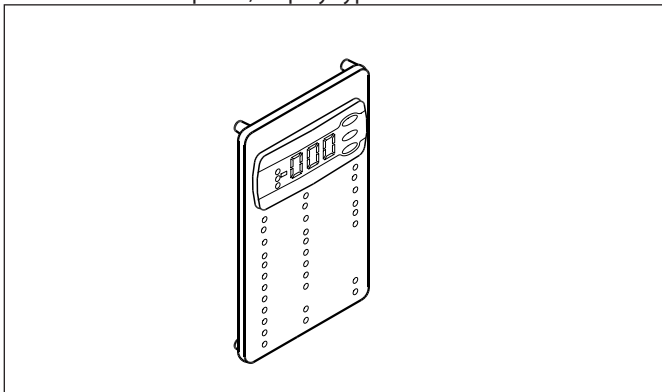

(The LED for "Oil" and "Heat" is not active on this controller.)

### Graphic display AK-MMI

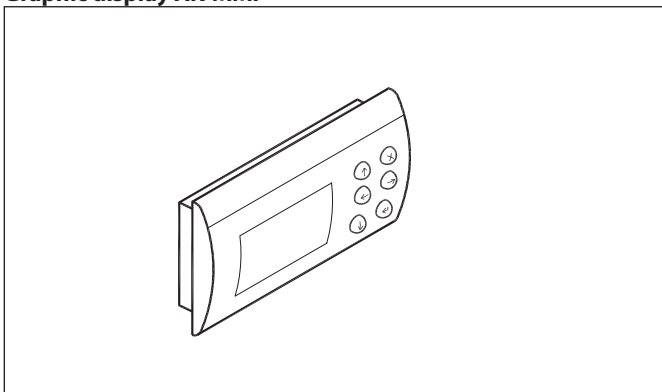

With the display is access to most of the controller functions.

### Light-emitting diodes on the controller

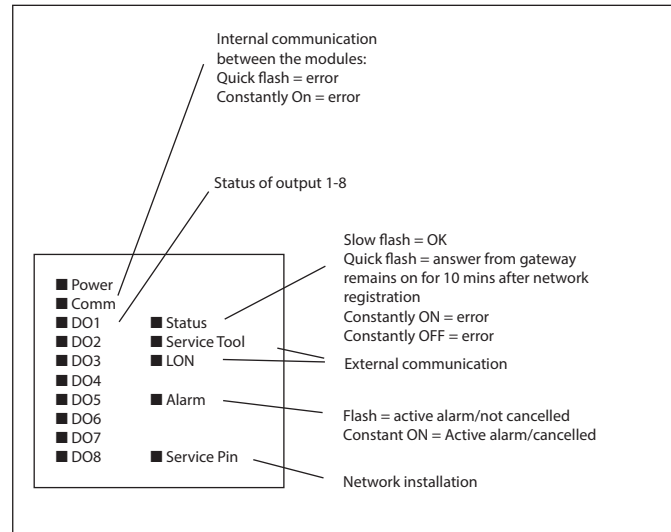

# Appendix A – Compressor combinations and coupling patterns

In this section, there is a more detailed description of the compressor combinations and the associated coupling patterns. Sequential operation is omitted from the examples since the compressors are only connected in accordance with their compressor number (First In - Last Out principle) and only speed-regulated compressors are used to fill capacity gaps.

## Compressor application = single step

The capacity distributor is capable of managing up to 6 one-step compressors according to the following coupling patterns:

- Sequential
- Cyclical
- Best fit

### Cyclical operation - example

Here, all compressors are of the same size and the compressors are cut in and cut-out in accordance with the First-In-First-Out (FIFO) principle, in order to equalise operating hours between the compressors.

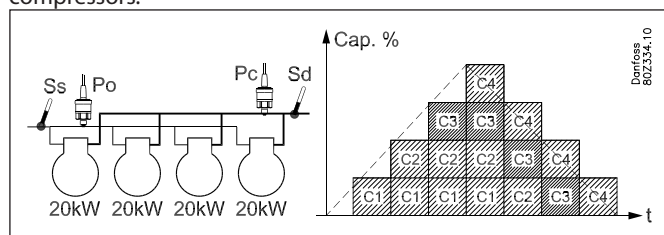

- There is operating time equalizing between all compressors
- The compressor with the fewest running hours starts first
- The compressor with the most running hours stops first.

### Best fit - example

Here at least two compressors are of different sizes. The capacity distributor will cut in and cut-out the compressors to produce the best possible capacity fit (the least possible capacity jump).

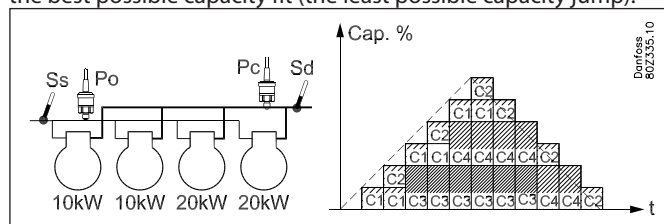

- There is operating time equalizing between the compressors 1 and 2 (same size in example).
- There is operating time equalizing between the compressors 3 and 4 (same size in example).

## Compressor application = 1 x Speed + single step

The controller is capable of controlling one speed-regulated compressor combined with one-step compressors of the same or different sizes.

Preconditions for using this compressor application are:

- A speed-regulated compressor that can be of a different size than the following one-step compressors
- Up to 5 one-step compressors of the same or different capacity (depending on coupling pattern)

This compressor combination can be handled in accordance with the following coupling patterns:

- Sequential
- Cyclical
- Best fit

Handling the speed-regulated compressor.

For more information on the general handling of the speed-regulated compressor, refer to section "Power pack types".

### Cyclical operation - example

Here, the one-step compressors are of the same size.

The speed-regulated compressor is always the first to start and the last to stop.

One-step compressors should be cut in and cut out in accordance with the First-In-First-out principle in order to equalise operating hours.

The speed-regulated compressor is used to fill the capacity gaps between the one-step compressors.

### Example:

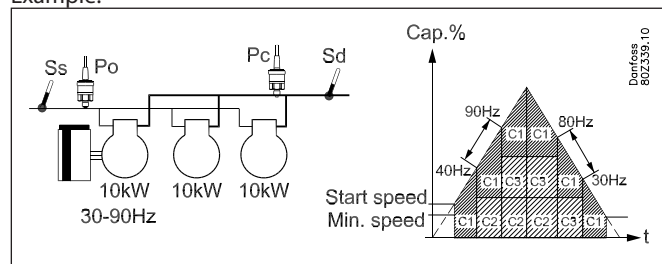

Increasing capacity:

- The speed-regulated compressor starts when the desired capacity equals the start speed
- The following one-step compressor with the smallest number of operating hours cut in when the speed-regulated compressor is running at full speed (90 Hz)
- When a one-step compressor cuts in, the speed-regulated compressor reduces speed (40 Hz) equivalent to the capacity of the one-step compressor.

#### Decreasing capacity:

- The following one-step compressors with the most operating hours should be cut out when the speed-regulated compressor reaches minimum speed (30 Hz)
- When a one-step compressor is cut out, the speed-regulated compressor's speed increases (80 Hz), equivalent to the capacity of the one-step compressor
- The speed-regulated compressor is the last compressor to be cut out when the preconditions for this are fulfilled.

#### Best fit - example:

Here, at least two of the one-step compressors are of different sizes.

The speed-regulated compressor is always the first to start and last to stop.

The capacity distributor cuts in and cuts out the one-step compressors in order to achieve the best possible capacity fit (least possible capacity jump)

The speed-regulated compressor is used to fill out the capacity gaps between the one-step compressors.

#### Example:

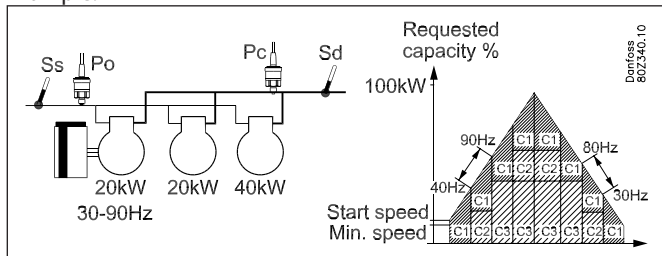

#### Increasing capacity:

- The speed-regulated compressor starts when the desired capacity matches the start speed
- The smallest one-step compressor is cut in when the speed-regulated compressor runs at full-speed (90 Hz).
- When the speed-regulated compressor again reaches max. speed (90 Hz), the smallest one-step compressor is cut out (C2) and the big one-step compressor (C3) is cut in.
- When the speed-regulated compressor again reaches max speed (90 Hz), the smallest one-step compressor (C2) is cut in again.
- When the one-step compressor is cut in, the speed is reduced on the speed-regulated compressor (40 Hz) equivalent to the capacity of the cut in capacity

#### Decreasing capacity:

- The small one-step compressor is cut out when the speed-regulated compressor has reached minimum speed (30 Hz)
- When the speed-regulated compressor again reaches minimum speed (30 Hz), the smallest one-step compressor (C2) is cut out and the big one-step compressor (C3) is cut in.
- When the speed-regulated compressor again reaches min. speed (30 Hz), the large one-step compressor (C3) is cut out and the small one-step compressor (C2) is cut in again.
- When the speed-regulated compressor again reaches min. speed (30 Hz), the small one-step compressor (C2) is cut in.
- The speed-regulated compressor is the last compressor to be cut out when the requirements for this are fulfilled.
- When the one-step compressor's capacity is cut out, the speed-regulated compressor increases speed (80 Hz) equivalent to the cut out capacity.

### **Installation considerations**

Accidental damage, poor installation, or site conditions, can give rise to malfunctions of the control system, and ultimately lead to a plant breakdown.

Every possible safeguard is incorporated into our products to prevent this. However, a wrong installation, for example, could still present problems. Electronic controls are no substitute for normal, good engineering practice.

Danfoss will not be responsible for any goods, or plant components, damaged as a result of the above defects. It is the installer's responsibility to check the installation thoroughly, and to fit the necessary safety devices.

Special reference is made to the necessity of signals to the controller when the compressor is stopped and to the need of liquid receivers before the compressors.

Your local Danfoss agent will be pleased to assist with further advice, etc.

