



DSA 1 MINI Standard

Welded district heating stations

Description

The DSA 1 MINI is a welded district heating station. It is designed to transfer thermal energy from a local or from a district heating network to the heating or domestic water system in a building. The station comprises devices as well as offers functionalities necessary to meet different district heating network connection conditions.

Applications

The DSA 1 MINI station has been designed to secure high efficiency of the thermal energy transfer and thus offer the best possible performance as the thermal energy source for a building.

The district heating network, being the primary side, and the heating or the domestic water systems in a building, being the secondary side, may need to be hydraulically separated from each other. To secure this the station comprises a heat exchanger.

The DSA 1 MINI station also offers devices and equipment for controlling and monitoring the contracted flows and temperatures as well as for measuring the used in the building energy.

The station design follows the main standards and requirements. Consequently, the stations can cover a wide range of applications in different markets.

Ordering

Product code numbers

DSA 1 MINI		Total heat consumption measurement		Heat consumption measurement only HE		Weight approx. [kg]
Type	Nominal capacity Q _p [kW]	Primary side connection				
		left	right	left	right	
		code	code	code	code	
H1__	20	146B5559	146B5564	-	-	49
H1__	35	146B5560	146B5565	-	-	51
H1__	50	146B5561	146B5566	-	-	54
H1__	85	146B5562	146B5567	-	-	56
F1__	25	146B5569	146B5572	-	-	59
F1__	50	146B5570	146B5573	-	-	60
H1WS	20	146B5575	146B5580	-	-	56
H1WS	35	146B5576	146B5581	-	-	58
H1WS	50	146B5577	146B5582	-	-	61
H1WS	25	146B5578	146B5583	-	-	63
F1WS	50	146B5585	146B5588	-	-	56
F1WS	70	146B5586	146B5589	-	-	66
F1WS (MIX)	25	146B5591	146B5594	-	-	57
F1WS (MIX)	50	146B5592	146B5595	-	-	67
F1WS (MIX)	70	146B5593	146B5596	-	-	68
H1WP	20	146B5597	146B5602	146B5613	146B5618	52
H1WP	35	146B5598	146B5603	146B5614	146B5619	54
H1WP	50	146B5599	146B5604	146B5615	146B5620	57
H1WP	85	146B5600	146B5605	146B5616	146B5621	59
F1WP	25	146B5607	146B5610	146B5623	146B5626	62
F1WP	50	146B5608	146B5611	146B5624	146B5627	63
H2WP	20	146B5629	146B5633	146B5637	146B5641	65
H2WP	35	146B5630	146B5634	146B5638	146B5642	66
H2WP	50	146B5631	146B5635	146B5639	146B5643	68
H2WP	85	146B5632	146B5636	146B5640	146B5644	70
B1__	60	146B5743	146B5745	-	-	54
B1__	100	146B5744	146B5746	-	-	56

Overview

Product portfolio

Dimensions / circuit diagram:

(Type H1_/F1_: Heating or floor heating)

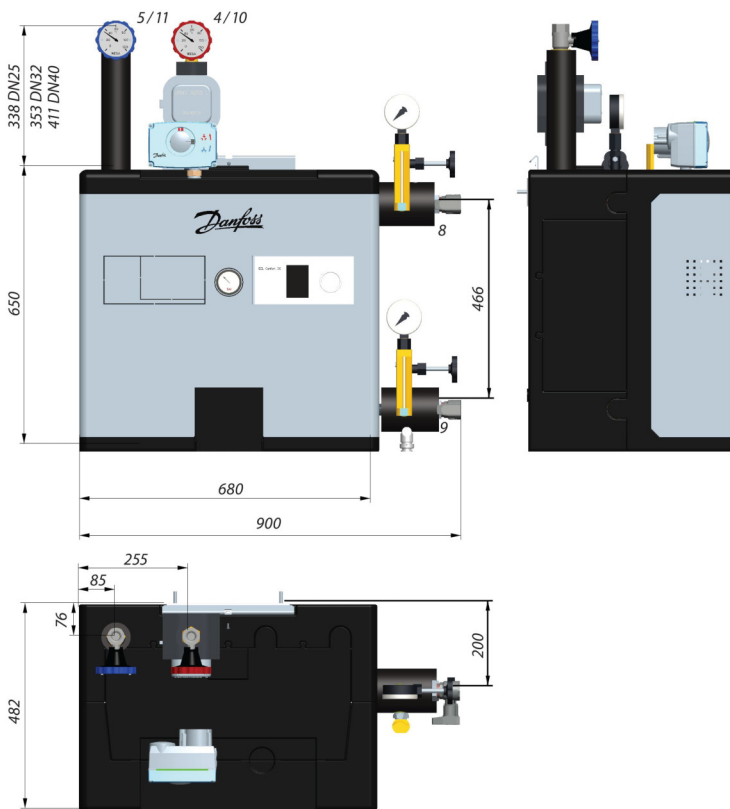
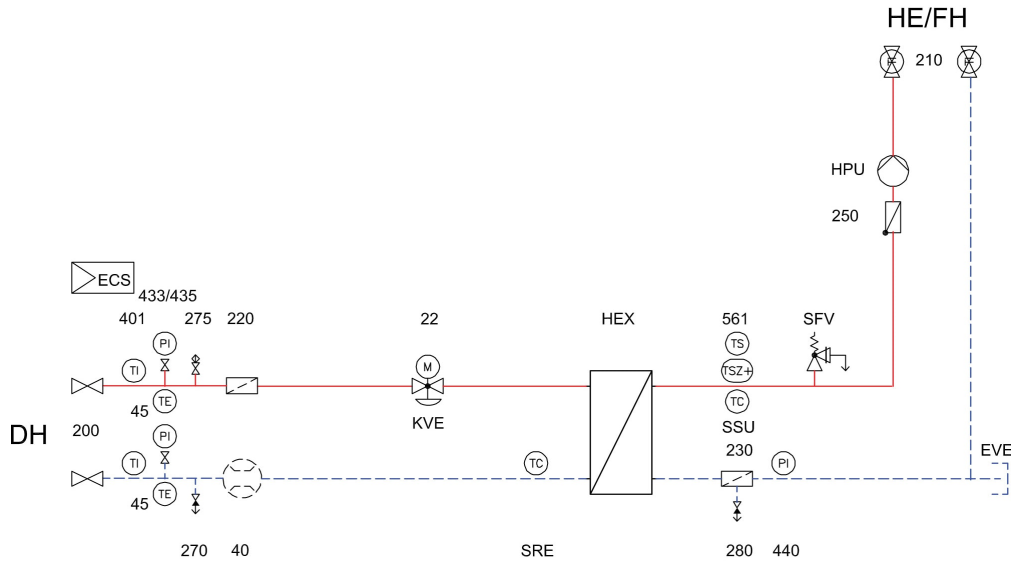

Primary side right
 Secondary side up (connection from the bottom is available as an option)
 Primary side left as an option
 See table with product codes

- 4 Heating, supply
- 5 Heating, return
- 8 District heating, supply
- 9 District heating, return
- 10 Floor heating, supply
- 11 Floor heating, return

Dimensions / circuit diagram:
 (Type H1WS/F1WS: Heating and domestic hot water or floor heating and domestic hot water)

The station in this configuration must secure water temperature on the secondary side suitable for domestic hot water purposes (DHW), that is 65°C. If the station should serve floor heating purposes a mixing loop is required in the floor heating system to prevent too high temperature water from flowing directly into the floor heating loops.

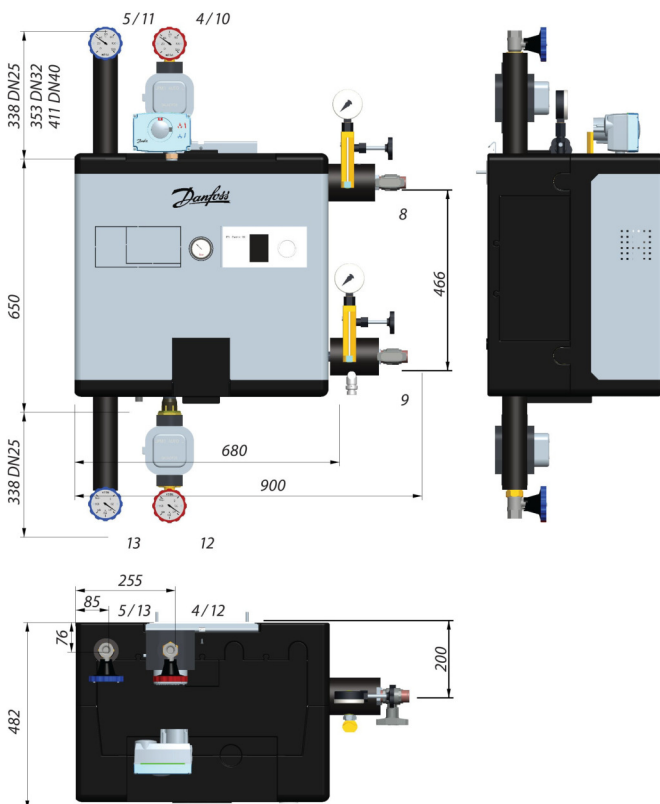
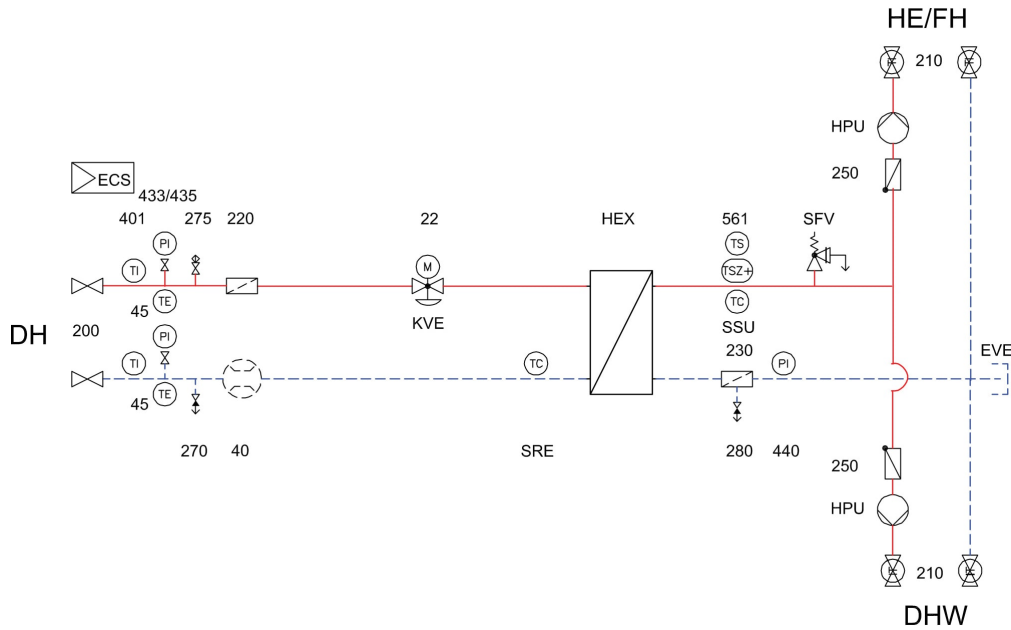

Primary side right
 Secondary side up and bottom
 Primary side left as an option
 See table with product codes

- 4 Heating, supply
- 5 Heating, return
- 8 District heating, supply
- 9 District heating, return
- 10 Floor heating, supply
- 11 Floor heating, return
- 12 DHW heating, supply
- 13 DHW heating, return

Dimensions / circuit diagram:
 (Type F1WS: Floor heating and domestic hot water F1WS (MIX))

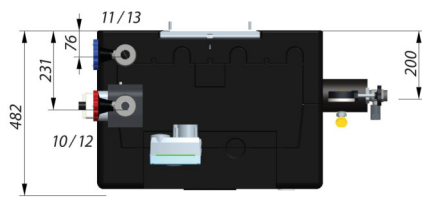
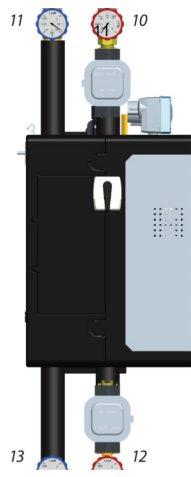
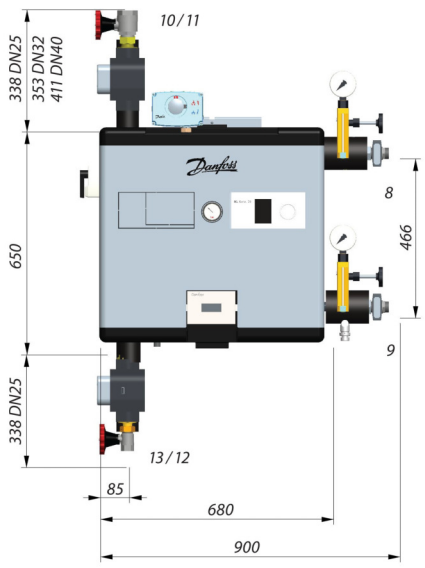
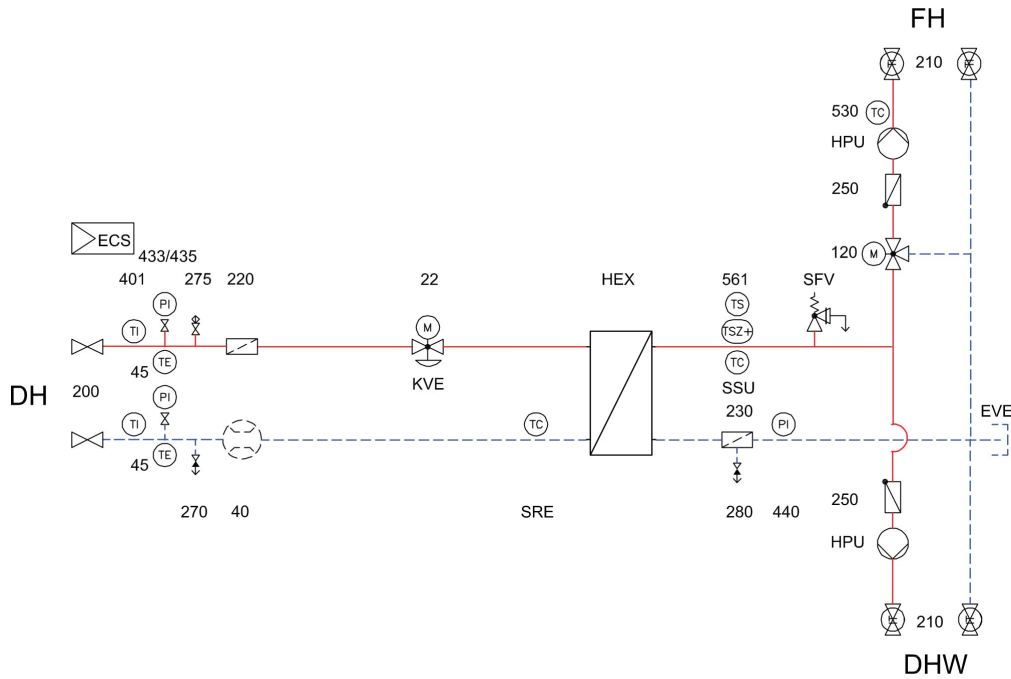

Primary side right
 Secondary side up and bottom
 Primary side left as an option
 See table with product codes

- 8 District heating, supply
- 9 District heating, return
- 10 Floor heating, supply
- 11 Floor heating, return
- 12 DHW heating, supply
- 13 DHW heating, return

Dimensions / circuit diagram:
 (Type H1WP/F1WP: Heating or floor heating and domestic hot water on the primary side Variant 1: Total heat consumption measurement)

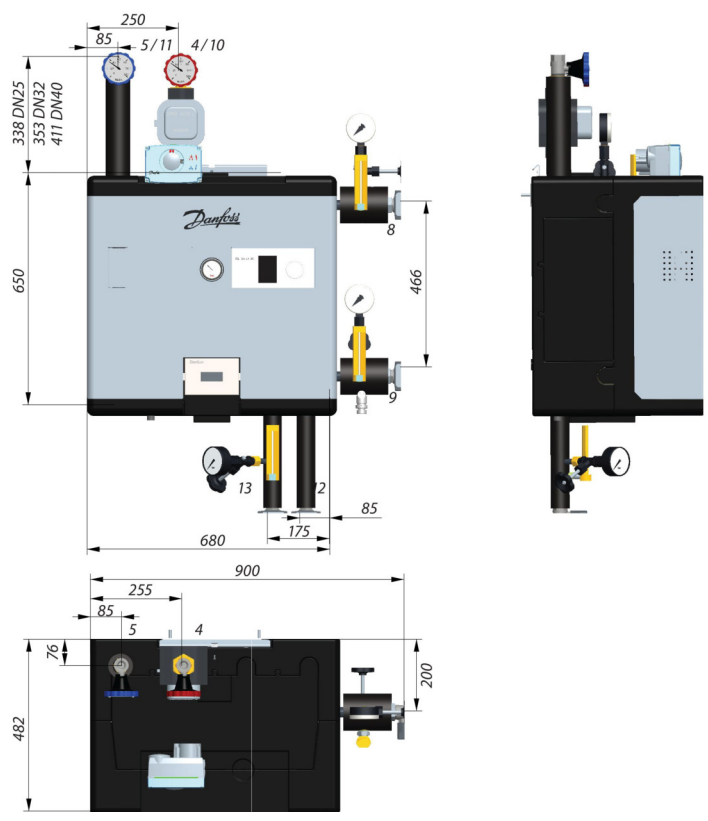
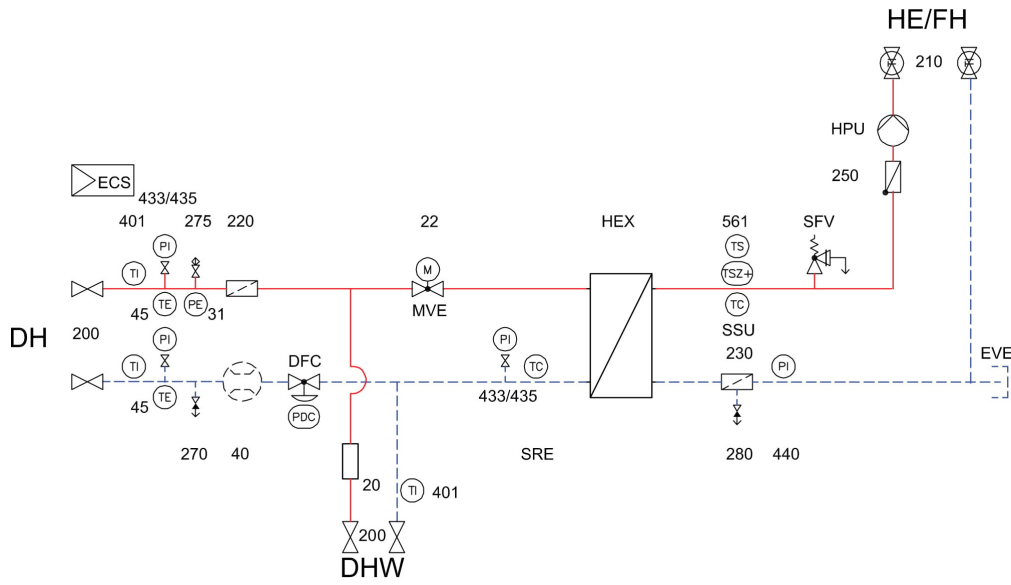

Primary side right
 Secondary side up (connection from the bottom is available as an option)
 Primary side left as an option
 See table with product codes

- 4 Heating, supply
- 5 Heating, return
- 8 District heating, supply
- 9 District heating, return
- 10 Floor heating, supply
- 11 Floor heating, return
- 12 DHW heating, supply
- 13 DHW heating, return

Dimensions / circuit diagram:

(Type H1WP/F1WP: Heating or floor heating and domestic hot water on the primary side Variant 2: Only HE/FH heat consumption measurement)

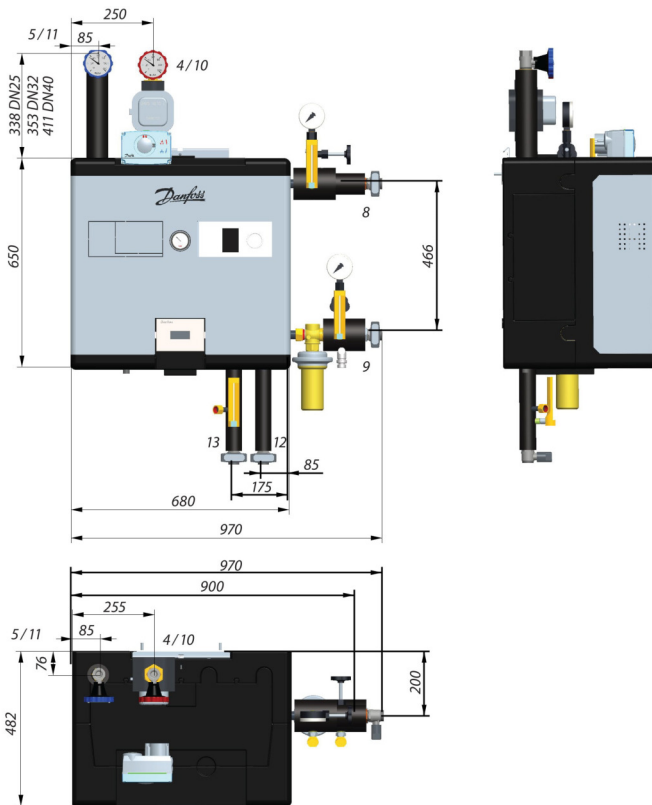
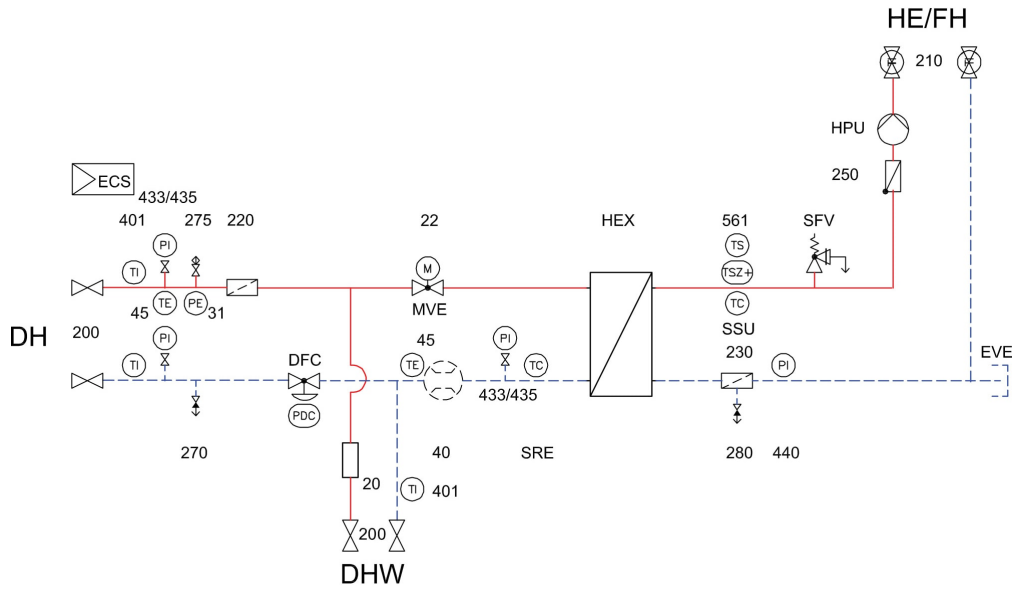

Primary side right
 Secondary side up (connection from the bottom is available as an option)
 Primary side left as an option
 See table with product codes

- 4 Heating, supply
- 5 Heating, return
- 8 District heating, supply
- 9 District heating, return
- 10 Floor heating, supply
- 11 Floor heating, return
- 12 DHW heating, supply
- 13 DHW heating, return

Dimensions / circuit diagram:

(Type H2WP: Heating and floor heating; domestic hot water on the primary side Variant 1: Total heat consumption measurement)

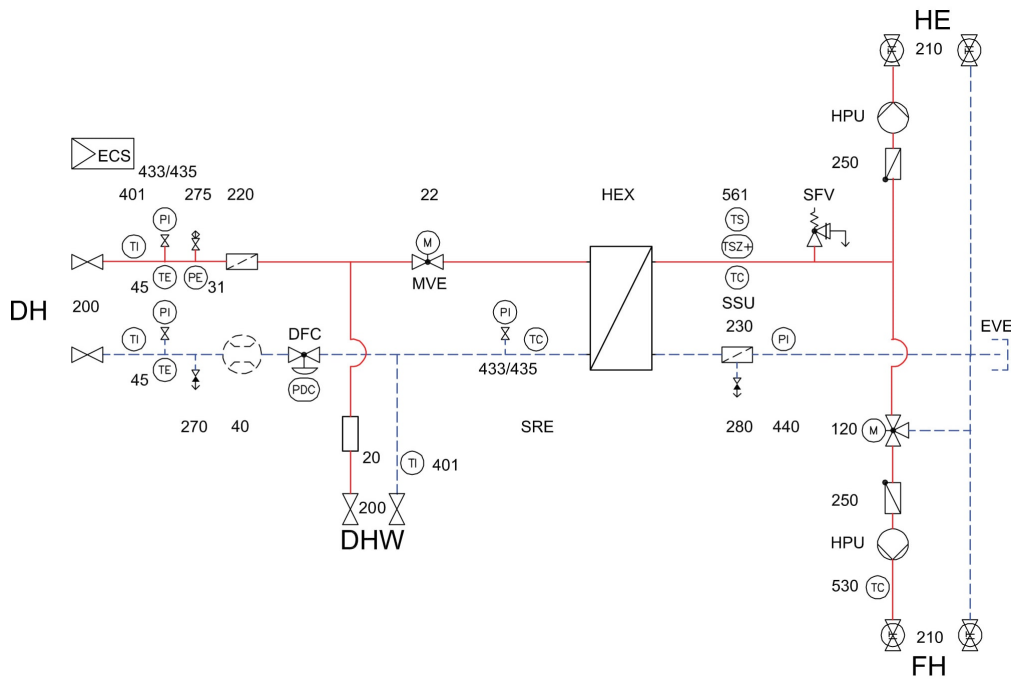

Primary side right
 Secondary side up and bottom
 Primary side left as an option
 See table with product codes

- 4 Heating, supply
- 5 Heating, return
- 8 District heating, supply
- 9 District heating, return
- 10 Floor heating, supply
- 11 Floor heating, return
- 12 DHW heating, supply
- 13 DHW heating, return

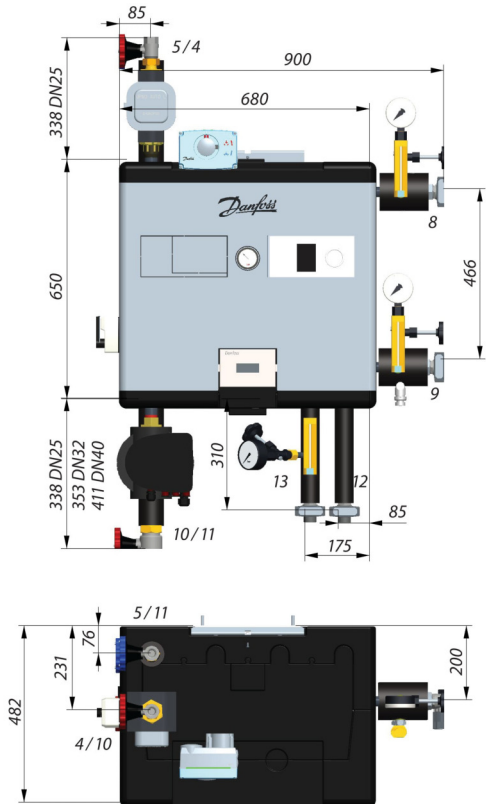

Dimensions / circuit diagram:

(Type H2WP: Heating and floor heating; domestic hot water on the primary side Variant 2: Only HE/FH heat consumption measurement)

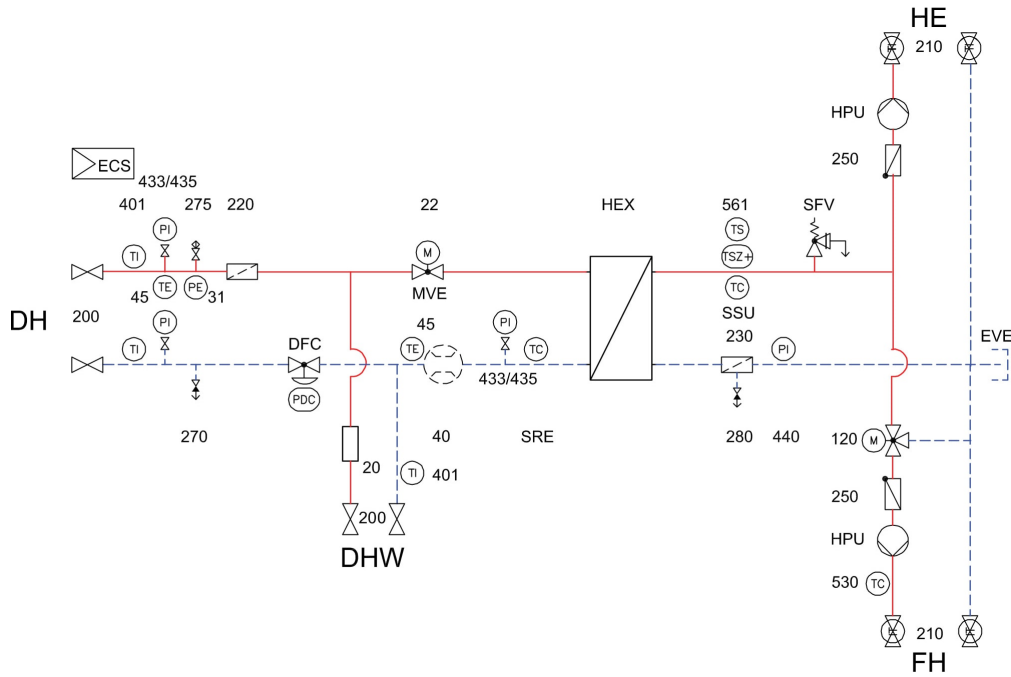

Primary side right
 Secondary side up and bottom
 Primary side left as an option
 See table with product codes

- 4 Heating, supply
- 5 Heating, return
- 8 District heating, supply
- 9 District heating, return
- 10 Floor heating, supply
- 11 Floor heating, return
- 12 DHW heating, supply
- 13 DHW heating, return

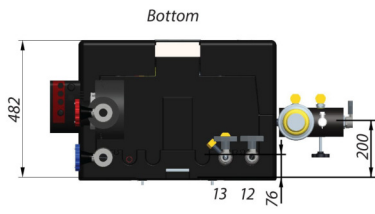
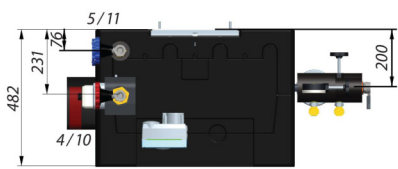
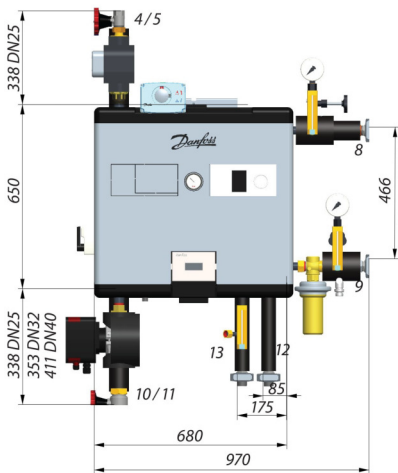

Dimensions / circuit diagram:
 (Type B1__: 1 x buffer tank charging controlled with a PWM pump)

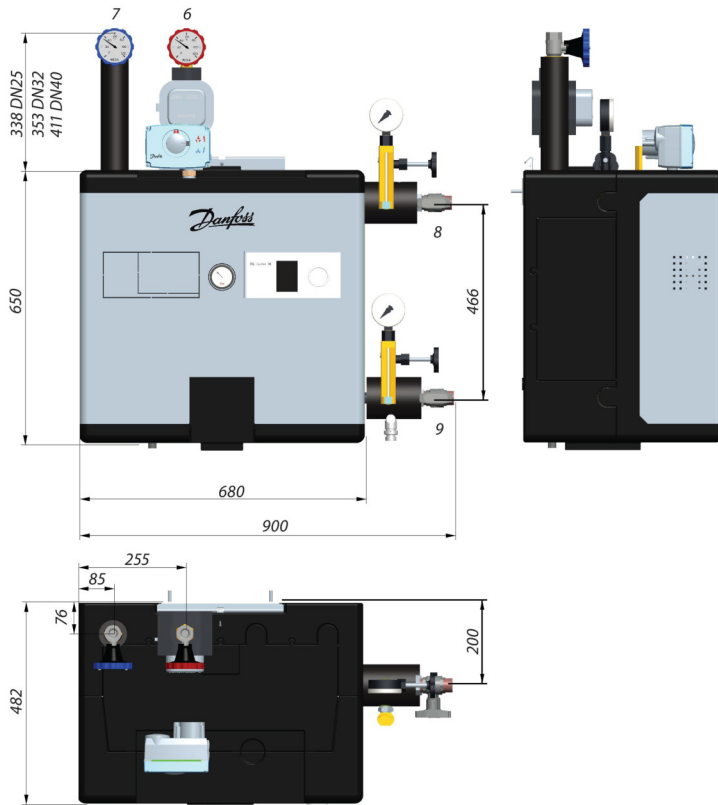
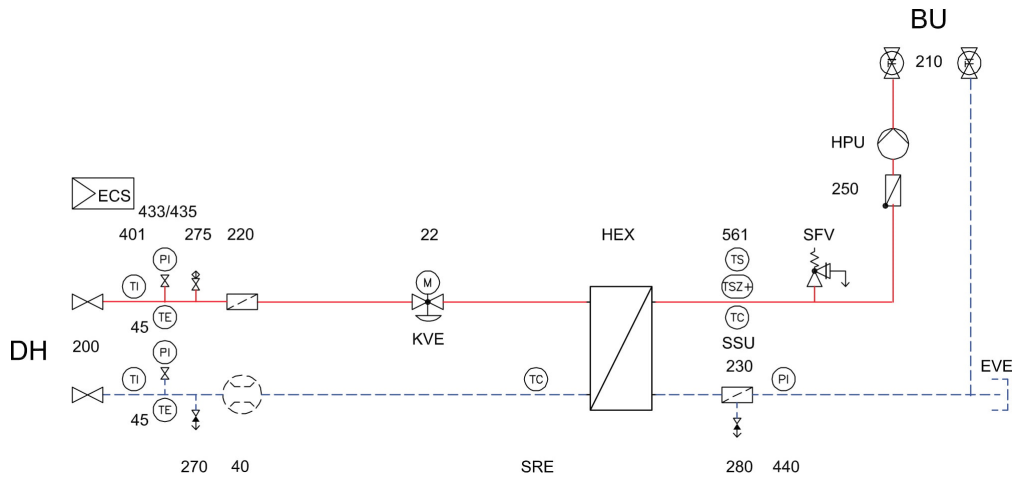

Primary side right
 Secondary side up (connection from the bottom is available as an option)
 Primary side left as an option
 See table with product codes

- 6 Buffer supply
- 7 Buffer return
- 8 District heating, supply
- 9 District heating, return

Components

HEX	Microplate heat exchanger (MPHE), brazed, type: XB12
MVE	Motorized valve, PN25/max. 150°C, type VM2
20	Insert (a piece of pipe) instead of a motorized or picv valve
22	Actuator, 3-point, with safety function, type AMV 13/23
KVE	PICV control valve, PN25/max. 150°C, type AVQM
DFC	Differential pressure control valve with flow limitation, PN25/max. 150°C, setting: 0.2-1.0 bar, type AVPB
31	Connection for a capillary of a differential pressure control valve with flow limitation (DFC)
40	Insert (a piece of pipe) instead of a heat meter
45	Temperature sensor fitting for a heat meter - a pocket or an adapter for a directly mounted sensor
200	Ball valve, PN25/max. 150°C, G1" ext. ISO 228/1
220	Strainer, PN25/max. 150°C, G1" or G1 1/4" ext. ISO 228/1
270	High-pressure drain, PN25/max. 150°C, G3/4", hose connection, with cap and chain
275	High pressure air vent, PN25/max. 150°C, G1/4"
401	Industrial thermometer, 0 – 160°C, 2grd, NG 150
433	Manometer, size DA = 80 mm, 0-25 bar, class 1.0, G1/2"
435	Shut-off valve of a manometer G1/4" or G1/2" with an extension piece and a pressure shock reducer
SRE	Return temperature limiter sensor PT1000
SFV	Safety valve, opening pressure: 3.0 bar, TÜV
HPU	Pump, electronic, EEL ≤ 0.23, producer: GRUNDFOS
120	3-way mixing valve with an actuator, PN10/max. 110°C, type HRB/AMB162
210	Ball valve, PN16/max. 120°C, G1" – G1 1/2" int. ISO 228/1, with an integrated bimetal thermometer size: DA = 80, class 1.0, 0°C to 120°C
230	Strainer, PN16/max. 120°C, Rp 1 1/4"
250	Non-return valve insert, PN10/max. 120°C, G1 1/2" or G2"
280	Drain, PN16/max. 120°C, G3/4" with hose connection and a cap with chain
EVE	Expansion vessel connection, Rp 3/4" with plug
440	Manometer, size DA = 50 mm, 0 – 4 bar, class 2.5, capillary type
ECS	Electronic controller in a control box, ECL310
SSU	Secondary side supply temperature sensor, PT1000
530	Secondary side supply temperature contact sensor, PT1000
561	Safety thermostat, TR/STW or TW/STW or TR/STB
DH	District heating
HE	Heating secondary side (general)
FH	Floor heating
DHW	Domestic hot water
BU	Buffer tank

Functions

Operation

The DSA 1 MINI is an indirect type of a station. It uses a plate heat exchanger for the thermal energy transfer purposes and to separate the network from the heating or from the domestic hot water systems in a building.

To secure a high efficiency thermal energy transfer water shall not carry air bubbles nor dirt into the heat exchanger. To ensure this the DSA 1 MINI station comprises an air vent and a strainer on the primary side.

The heat transfer process must be controlled so that the required temperature of water on the secondary side is achieved. Water temperature is measured using sensors mounted on the primary and on the secondary sides. The readings from the sensors are processed in the controller which translates these into signals that can be used in the actuators of 2-way control valves or pressure independent control valves with flow limitation mounted on the primary side of the station.

Differential pressure control valves with flow limitation are mounted in stations which use 2-way control valves. Thanks to this setup the differential pressure across 2-way control valves is stabilized securing a high authority of these and the desired precision of flow control. At the same time the contracted flow is never exceeded.

A station can be connected to a network if it fulfills the utility company technical conditions. These, amongst other, define the requirements concerning the measuring equipment.

Since hot water from a local or from a district heating network is delivered to DSA 1 MINI station at different pressures and temperatures - the water temperature varies based on the outdoor conditions and depending on the season of the year - the quality of the measuring equipment is vital.

The DSA 1 MINI station complies with the requirements by offering thermometers and manometers designed particularly for district heating applications on the primary side. For more flexibility the station is offered with an insert - a piece of pipe - instead of an energy meter which can be selected and installed by the end user at a later stage.

Naturally, there is a selection of Danfoss energy meters that can be used in DSA 1 MINI as well.

The station is equipped with shut-off valves for service purposes and offers an option of connecting an external domestic hot water (DHW) system on the primary side.

After transferring thermal energy from the primary to the secondary side water flows from the heat exchanger through the return lines on the primary side back to the local or the district heating network.

To distribute the thermal energy on the secondary side, pumps circulating water to radiator (HE), floor heating (FH), domestic hot water (DHW) or other systems are used.

On the secondary side the DSA 1 MINI station offers a selection of standard and optional items such as 3-way control valves in circuits with mixing loops, safety valves, safety thermostats, strainers with drain valves, connections for expansion vessels, manometers, check valves, shut off valves and thermometers.

The station can be configured to suit the local connection conditions. The pipes on the primary side may be connected from the left or from the right while the pipes on the secondary side from the bottom or from the top. In addition to this the station can be optionally delivered with one or with two circuits on the secondary side as well as with or without a connection to the external domestic hot water system on the primary side.

In stations with a connection to the external domestic hot water system the heat meter or an insert replacing the heat meter may be installed in a way so that the total thermal energy consumption is measured or the circuit with the external domestic hot water system is excluded from the measurement.

The DSA 1 MINI station offers a lot of flexibility for the best performance in numerous applications.

Maximum operating parameters

Primary side		
Maximum supply temperature	TVP	130°C
Maximum operating pressure	PZP	25 bar(g)
Nominal pressure	PN	25
Maximum differential pressure	DPP	20 bar
Maximum flow rate	VZP	2.50 m ³ /h at velocity ≤ 1.1 m/s
Secondary side		
Maximum supply temperature	TVS	95°C
Maximum operating pressure	PZS	3 bar(g) (safety valve opening)
Nominal pressure	PN	6
Maximum flow rate	VZS	5.10 m ³ /h at w ≤ 1.0 m/s



Product details

General data

Technical data

Primary side

Type	QP max	Control valve	KVS	Actuator type	Diff. pressure control valve		Insert (in place of heat meter)	Number of plates of heat exch. MPHE	DN	QP max.	dp max.	DN	QP max.	Control valve
	kW	type	m ³ /h	AMV	type	KVS			Primary side total			Connection primary DHW		
								m ³ /h	kPa		kW	Insert [mm]		
H1__	20	AVQM	1	AMV13	-	-	G¾"×110	M-1-16	G1"	0,36	42	-	-	-
H1__	35	AVQM	1,6	AMV13	-	-	G¾"×110	M-1-20	G1"	0,63	45	-	-	-
H1__	50	AVQM	2,5	AMV13	-	-	G¾"×110	M-1-30	G1"	0,89	42	-	-	-
H1__	85	AVQM	4	AMV13	-	-	G1"×190	M-1-50	G1"	1,52	44	-	-	-
F1__	25	AVQM	1	AMV13	-	-	G¾"×110	L-1-20	G1"	0,36	43	-	-	-
F1__	50	AVQM	2,5	AMV13	-	-	G¾"×110	L-1-40	G1"	0,71	38	-	-	-
H1WS	20	AVQM	1	AMV13	-	-	G¾"×110	M-1-16	G1"	0,36	42	-	-	-
H1WS	35	AVQM	1,6	AMV13	-	-	G¾"×110	M-1-20	G1"	0,63	45	-	-	-
H1WS	50	AVQM	2,5	AMV13	-	-	G¾"×110	M-1-30	G1"	0,89	42	-	-	-
H1WS	85	AVQM	4	AMV13	-	-	G1"×190	M-1-50	G1"	1,52	44	-	-	-
H1WS	25	AVQM	1	AMV13	-	-	G¾"×110	L-1-20	G1"	0,36	43	-	-	-
F1WS	50	AVQM	2,5	AMV13	-	-	G¾"×110	L-1-40	G1"	0,71	38	-	-	-
F1WS (MIX)	25	AVQM	1	AMV13	-	-	G¾"×110	M-1-16	G1"	0,45	49	-	-	-
F1WS (MIX)	50	AVQM	2,5	AMV13	-	-	G¾"×110	M-1-20	G1"	0,89	42	-	-	-
F1WS (MIX)	70	AVQM	2,5	AMV13	-	-	G¾"×110	M-1-30	G1"	1,25	54	-	-	-
H1WP	20	VM2	1	AMV13	AVPB	1,6	G¾"×110	M-1-16	G1"	0,36	47	G1"	19	G¾"×65
H1WP	35	VM2	1,6	AMV13	AVPB	1,6	G¾"×110	M-1-20	G1"	0,63	59	G1"	33	G¾"×65
H1WP	50	VM2	2,5	AMV13	AVPB	2,5	G¾"×110	M-1-30	G1"	0,89	55	G1"	47	G¾"×65
H1WP	85	VM2	4	AMV13	AVPB	4	G1"×190	M-1-50	G1"	1,52	58	G1"	80	G¾"×65
F1WP	25	VM2	1	AMV13	AVPB	1,6	G¾"×110	L-1-20	G1"	0,36	48	G1"	19	G¾"×65
F1WP	50	VM2	2,5	AMV13	AVPB	2,5	G¾"×110	L-1-40	G1"	0,71	46	G1"	38	G¾"×65
H2WP	20	VM2	1	AMV13	AVPB	1,6	G¾"×110	M-1-16	G1"	0,36	47	G1"	19	G¾"×65
H2WP	35	VM2	1,6	AMV13	AVPB	1,6	G¾"×110	M-1-20	G1"	0,63	59+	G1"	33	G¾"×65
H2WP	50	VM2	2,5	AMV13	AVPB	2,5	G¾"×110	M-1-30	G1"	0,89	55	G1"	47	G¾"×65
H2WP	85	VM2	4	AMV13	AVPB	4	G1"×190	M-1-50	G1"	1,52	58	G1"	80	G¾"×65
B1__	60	AVQM	4	AMV13	-	-	G¾"×110	H-1-50	G1"	1,43	47	-	-	-
B1__	100	AVQM	6,3	AMV23	-	-	G1"×190	H-1-80	G1"	2,38	49	-	-	-

Secondary side

Type	DN	QP max.	dpr max.	DN	VP max.	dpr max.	DN	VP max.	dpr max.	Safety valve	Safety thermostat
	Connection secondary DHW			Secondary side heating			Secondary side FH heating				
		kW	kPa		m ³ /h	kPa		m ³ /h	kPa		
H1__	-	-	-	Rp 1"	0,86	49	-	-	-	½" / 3.0 / TÜV	AT120/0..120/20..150°C
H1__	-	-	-	Rp 1"	1,50	66	-	-	-	½" / 3.0 / TÜV	AT120/0..120/20..150°C
H1__	-	-	-	Rp 1"	2,14	58	-	-	-	½" / 3.0 / TÜV	AT120/0..120/20..150°C
H1__	-	-	-	Rp 1¼"	3,64	35	-	-	-	½" / 3.0 / TÜV	AT120/0..120/20..150°C
F1__	-	-	-	-	-	-	Rp 1"	2,14	57	½" / 3.0 / TÜV	AT120/0..120/20..150°C
F1__	-	-	-	-	-	-	Rp 1½"	4,29	34	½" / 3.0 / TÜV	AT120/0..120/20..150°C
H1WS	Rp 1"	10	54	Rp1"	0,86	49	-	-	-	½" / 3.0 / TÜV	AT120/0..120/20..150°C
H1WS	Rp 1"	18	46	Rp1"	1,50	66	-	-	-	½" / 3.0 / TÜV	AT120/0..120/20..150°C
H1WS	Rp 1"	25	46	Rp1"	2,14	58	-	-	-	½" / 3.0 / TÜV	AT120/0..120/20..150°C
H1WS	Rp 1"	43	39	Rp 1¼"	3,64	35	-	-	-	½" / 3.0 / TÜV	AT120/0..120/20..150°C
H1WS	Rp 1"	10	54	-	-	-	Rp 1"	2,14	57	½" / 3.0 / TÜV	AT120/0..120/20..150°C
H1WS	Rp 1"	18	46	-	-	-	Rp 1½"	4,29	34	½" / 3.0 / TÜV	AT120/0..120/20..150°C
F1WS (MIX)	Rp 1"	10	54	-	-	-	Rp 1"	2,14	52	½" / 3.0 / TÜV	AT120/0..120/20..150°C
F1WS (MIX)	Rp 1"	18	46	-	-	-	Rp 1½"	4,29	32	½" / 3.0 / TÜV	AT120/0..120/20..150°C
F1WS (MIX)	Rp 1"	25	46	-	-	-	Rp 1½"	6,00	21	½" / 3.0 / TÜV	AT120/0..120/20..150°C
H1WP	-	-	-	Rp 1"	0,86	49	-	-	-	½" / 3.0 / TÜV	AT120/0..120/20..150°C
H1WP	-	-	-	Rp 1"	1,50	66	-	-	-	½" / 3.0 / TÜV	AT120/0..120/20..150°C
H1WP	-	-	-	Rp 1"	2,14	58	-	-	-	½" / 3.0 / TÜV	AT120/0..120/20..150°C
H1WP	-	-	-	Rp 1¼"	3,64	35	-	-	-	½" / 3.0 / TÜV	AT120/0..120/20..150°C
F1WP	-	-	-	-	-	-	Rp 1"	2,14	57	½" / 3.0 / TÜV	AT120/0..120/20..150°C
F1WP	-	-	-	-	-	-	Rp 1½"	4,29	34	½" / 3.0 / TÜV	AT120/0..120/20..150°C
H2WP	-	-	-	Rp 1"	0,26	54	Rp 1"	1,20	43	½" / 3.0 / TÜV	AT120/0..120/20..150°C
H2WP	-	-	-	Rp 1"	0,45	46	Rp 1"	3,10	46	½" / 3.0 / TÜV	AT120/0..120/20..150°C
H2WP	-	-	-	Rp 1"	0,64	46	Rp 1¼"	3,00	36	½" / 3.0 / TÜV	AT120/0..120/20..150°C
H2WP	-	-	-	Rp 1"	1,09	38	Rp 1½"	5,10	36	½" / 3.0 / TÜV	AT120/0..120/20..150°C
B1__	-	-	-	Rp 1"	1,14	65	-	-	-	½" / 3.0 / TÜV	AT120/0..120/20..150°C
B1__	-	-	-	Rp 1"	1,90	49	-	-	-	½" / 3.0 / TÜV	AT120/0..120/20..150°C

Note: For variants with 2 secondary heating circuits (type H2WP), the distribution of the total power is 70% floor heating and 30% the other heating circuit dp max – max pressure loss on the primary or secondary sides, VP max – max flow on the primary or secondary sides, dpr - residual pressure - pump head that can be used to circulate water in the system (system pressure loss must be lower than dpr)

Types / designation

DSA 1 MINI Standard		
Code	D L/R U/O/B YYY H1/F1/H2/B1 WP/WS EN	
D	Controller type	D = Danfoss ECL 310
L/R	Primary side connection direction	L = Left R = Right
U/O/B	Secondary side connection direction	U = Bottom O = Top B = top+bottom for 2 heating circuits
YYY	Capacity kW	20 kW: 020, 35 kW: 035, 50 kW: 050, 60 kW: 060, 70 kW: 070, 85 kW: 085, 100 kW: 100
H1/F1/H2/B1	Type of the heating circuit	H1 = one circuit on the secondary side (e.g. radiators) F1 = one floor heating circuit on the secondary side H2 = 2 heating circuits with 1 of them having a mixing valve on the secondary side B1 = a heating circuit for a buffer tank charging on the secondary side
WP/WS	Connection for an external domestic hot water (DHW) substation	WP = a connection for an external domestic hot water (DHW) substation on the primary side WS = a connection for an external domestic hot water (DHW) substation on the secondary side __ = no connection for an external domestic hot water (DHW) substation
EN	Substation's market code	All markets

Note:

The DSA 1 MINI substation may be delivered in different configurations and for different operating parameters. These can be defined using the online tool: heatselector.danfoss.com A station in a particular configuration is delivered with a dedicated application key for the ECL controller functionality and with accessories. The key covers the selected application. Should a substation be used for a different application compared to the originally selected, it may require the application key change and the accessories revision.

Example: DSA 1 MINI Standard DLU050H1WPEN

Substation type: DSA 1 MINI Standard with ECL 310 controller; primary side connection on the left, secondary side connection at the bottom, nominal capacity 50 kW, comprising a connection for an external domestic hot water (DHW) substation on the primary side, substation for all markets.

Materials

Pipes and fittings, flanges, moulded parts, unions	P235GH EN 10216-2, CW602N (CuZn36Pb2As), CW 617 N (CuZn40Pb2), EN 12165
Heat exchanger	1.4404 Cu brazed
Fittings and valves	CC499K (CuSn5Zn5Pb2-C) EN 1982, CW602N (CuZn36Pb2As) EN 12165
Insulation	37 ± 1/0 mm EPP rigid foam ($\lambda = 0.035$ W/mK) according to EN 12667; corresponds to 100% ENEC

Pressure and temperature data

Primary heating (winter)	°C	100 -> 52
Primary floor heating (winter)	°C	100 -> 40
Primary DHW buffer charging (winter...summer)	°C	130 .. 75 -> 39
Primary DHW (summer)	°C	70 -> 25
Secondary DHW buffercharging (winter and summer)	°C	70 -> 25
Secondary floor heating (winter)	°C	35 -> 45
Secondary DHW (summer)	°C	65 -> 30

In the case the requirements should deviate, the sizing must be checked.
Please contact our service center

Accessories

DSA 1 MINI, depending on the selected functionality - circuit diagram - is delivered with the accessories.
The accessories T1 are optional, and these must be ordered separately.

Accessory code	Accessory description	Marking in the drawing
168F0000	Temperature sensor PT 1000, mounting length 50 mm, cable length 5 m, max temperature 180°C, probe diameter 6 mm, cable Glands M12X1,5 3-7 mm, sensor pocket TF 1.4571 G $\frac{1}{2}$ " \times 100 mm, reduction coupling $\frac{3}{4}$ " \times $\frac{1}{2}$ " CW617N	S6 and S8
168F0001	Temperature sensor PT 1000, mounting length 50 mm, cable length 5 m, max temperature 180°C, probe diameter 6 mm, cable Glands M12X1,5 3-7 mm, sensor pocket TF 1.4571 G $\frac{1}{2}$ " \times 200 mm, reduction coupling $\frac{3}{4}$ " \times $\frac{1}{2}$ " CW617N	S4
168F0002	Thermostat type STW AT 20: safety temperature monitor range (STW): 40-100 °C, sensor connection G $\frac{1}{2}$ "	T1
168F0003	Double pocket for temperature sensor, length 200 mm	T1
168F0004	Temperature controller type TR and safety thermostat type STW AT 120: <ul style="list-style-type: none"> TR temperature range: 0-120 °C, STW safety temperature monitor range: 70-130 °C, Sensor connection G$\frac{1}{2}$" 	T1
168F0007	Insulation shell for a ball valve DN25-32, max temperature 135 °C	
168F0008	Insulation shell for a ball valve DN40-50, max temperature 135 °C	

Accessories – temperature sensors mounted in a tank - for DSA 1 MINI with a buffer tank circuit.

Accessories S6 and S8 are part of the DSA 1 MINI Standard delivery.

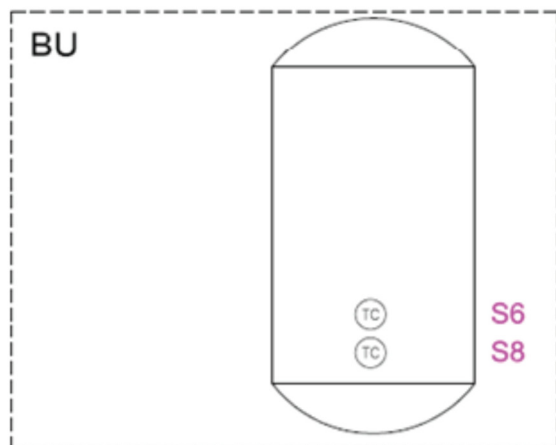

Accessories – temperature sensors mounted in a tank and in the supply line - for DSA 1 MINI with a domestic hot water circuit.
 Accessories S4, S6 and S8 are part of the DSA 1 MINI Standard delivery.

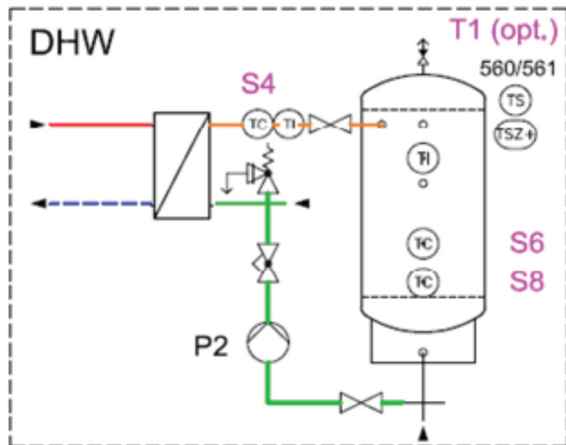

Certificates, declarations and approvals

The list contains all certificates, declarations, and approvals for this product type. Individual code number may have some or all of these approvals, and certain local approvals may not appear on the list.

When you click on the link you will be directed to the latest version of the 'Declaration of Conformity'. Products developed and sold before this date of issue conform to the directives/standards in force at the time of their sale.

Approval type	Title	Certification body	Approval topic
Declaration of Incorporation	Danfoss DOI PL32DOI000001en-000001.01	Danfoss	MD
Export Control Declaration	Sub stations and DHW systems	Danfoss	

Contact details

Online support

Danfoss offers a wide range of support along with our products, including digital information, software, mobile apps and expert guidance. See the possibilities below.



The Danfoss Design center

Discover the Design Center, our advanced digital platform that streamlines product selection. With integrated tools and enhanced type pages, it's simpler than ever to access product information and documentation, and to select the right products. Check the availability of Danfoss products at partner locations and enjoy seamless transitions from selection to purchase with our basket-to-basket functionality. Whether you're buying from our distributors or directly from the Product Store, the Design Center simplifies your experience. Learn more at: designcenter.danfoss.com.



The Danfoss product store

The Danfoss Product Store is a one-stop shop available 24/7 for our customers, no matter where you are in the world or what area of industry you work in. Browse our catalog, check product details and documentation, view your prices and product availability, and quickly finalize your purchase. Start browsing at: store.danfoss.com.



Danfoss Partner Portal/Product Data tool

Designed to support you with easy access to product data extracts, essential resources, tools, and information. The Partner Portal provides a centralized hub for product documentation, training materials, marketing assets, and technical support, ensuring you have everything you need to succeed and grow your business with Danfoss. The Partner Portal is available 24/7 at: partner.danfoss.com and is ready to support your business.



Find technical documentation

Find technical documentation you need to get your project up running. Get direct access to our official collection of data sheets, certificates and declarations, manuals and guides, 3D models and drawings, case stories, brochures, and much more. Start searching now at: documentation.danfoss.com.



Danfoss Learning

Danfoss Learning is a free online learning platform. It features courses and materials specifically designed to help engineers, installers, service technicians, and wholesalers better understand the products, applications industry topics, and trends that will help you do your job better. Find your local Danfoss website here: learning.danfoss.com.



Get local information and support

Local Danfoss websites are the main sources for help and information about our company and products. Find product availability, get the latest regional news, or connect with a nearby expert - all in your own language. Find your local Danfoss website here: danfoss.com.

Danfoss A/S

Climate Solutions . danfoss.com . +45 7488 2222

Any information, including, but not limited to information on selection of product, its application or use, product design, weight, dimensions, capacity or any other technical data in product manuals, catalogues description, advertisements, etc. and whether made available in writing, orally, electronically, online or via download, shall be considered informative, and is only binding if and to the extent, explicit reference is made in a quotation or order confirmation. Danfoss cannot accept any responsibility for possible errors in catalogues, brochures, videos and other material. Danfoss reserves the right to alter its products without notice. This also applies to products ordered but not delivered provided that such alterations can be made without changes to form, fit or function of the products. All trademarks in this material are property of Danfoss A/S or Danfoss group companies. Danfoss and the Danfoss logo are trademarks of Danfoss A/S. All rights reserved.
