

MAKING MODERN LIVING POSSIBLE



Technical Information

ACW112A,D

Level Controller



Phased Out Products

PRODUCT OVERVIEW

Description	4
Features	4
Ordering information.....	4-5
Specify	4
Replacement parts	4
Preferred Models.....	5
Part number quick reference	5
Dimensions.....	6
Technical data.....	7
Electrical data	7
Environmental data.....	7
Theory of operation.....	8
At level	8
Off level	8

PRODUCT INSTALLATION

Installation and adjustments	9-10
Installation.....	9
Mounting.....	9
Wiring	9
Connection diagram.....	9
Adjustments	10
Internal assembly with adjustment scale.....	10

DESCRIPTION

The ACW112 Level Controller measures deviation from a gravity reference for mobile equipment such as hillside combines and aerial lifts. Its sensing and amplifying components are contained within a single compact housing and are powered by either a 12 or 24 V DC electrical system.

The controller senses level through the interaction of a bearing-suspended magnetic pendulum and Hall proximity sensors. Signals from the Hall sensors drive the amplifier, which provides ON-OFF electric output to two solenoid valves. The switching signal is instantaneous on the ACW112A and is delayed one quarter to one half second on the ACW112D to allow it to disregard momentary slope deviations. Additionally, the ACW112D has short circuit protection. Both have instantaneous turn-off.

FEATURES

- Capable of operation under severe dust and moisture conditions
- Solid state circuitry
- Rugged aluminum housing
- Specially damped to resist response to normal machine oscillations
- Capable of driving solenoid valves directly, without additional signal amplification

ORDERING INFORMATION

See [part number quick reference](#), page 5 for listing of preferred models. Consult Sauer-Danfoss for other options.

Specify

1. Model number ACW112A or D Level Controller. Two controllers must be ordered for controlling two axes.
2. Voltage (12 or 24 V DC).
3. Setpoint desired.
4. Time delay (when ordering the ACW112D).

Replacement parts

1. Refill kits containing the correct amount of silicone fluid (200 cc) for refilling one controller. Order with part number K05993 for 1000 CS oil K05997 for 5000 CS oil.
2. Replacement Hall effect switch. Order part number K05116.

**ORDERING
INFORMATION
(continued)**
Preferred models
Part number quick reference

OS number	Voltage (V DC)	Time delay (seconds)	Switch Points	Oil viscosity (CS)
ACW112A1106	12	None	1.5°	5000
ACW112A1122	12	None	0.5°	5000
ACW112A1130	12	None	1°	5000
ACW112A1163	24	None	5°	5000
ACW112A1171	24	None	1.5°	5000
ACW112A1189	24	None	1°	5000
ACW112A1197	12	None	4.75°	5000
ACW112A1213	24	None	1°	4000
ACW112A1239	12	None	3°	5000
ACW112A1247	12	None	1.5°	1000
ACW112A1262	24	None	2°	5000
ACW112A1276	24	None	1.5°	1000
ACW112A1284	24	None	0.5°	5000
ACW112A1292	24	None	3°	5000
ACW112D1004	12	0.5	1°	1000
ACW112D1012	12	0.5	1°	50
ACW112D1020	12	0.5	1.5°	1000
ACW112D1038	24	0.5	1.5°	1000
ACW112D1046	24	1.5	1.5°	3000
ACW112D1061	24	0.5	1°	1000
ACW112D1079	12	0.25	1°	5000
ACW112D1087	12	0.25	1.5°	1000
ACW112D1095	24	0.5	5°	5000
ACW112D1111	24	0.25	1°	4000
ACW112D1129	12	1	1°	1000
ACW112D1137	24	0.75	1°	50
ACW112D1145	24	0.5	0.75°	1000
ACW112D1152	12	0.5	0.5°	1000
ACW112D1160	24	0.5	7°	5000
ACW112D1177	24	1	1°	300
ACW112D1186	12	0.5	3°	5000
ACW112D1194	24	0.5	1°	5000
ACW112D1202	12	0.5	5°	5000
ACW112D1226	12	205	7°	5000
ACW112D1234	12	1	4.7°	1000
ACW112D1242	12	0.5	1.5°	1000
ACW112D1250	12	0.5	4°	1000
ACW112D1268	12	205	7°	5000
ACW112D1282	12	0.5	5°	1000
ACW112D1296	12	0.5	7°	1000
ACW112D1304	24	0.25	1°	1000
ACW112D1312	12	0.5	1°	5000

DIMENSIONS

Approximate mounting dimensions of the ACW112 in millimeters [inches].

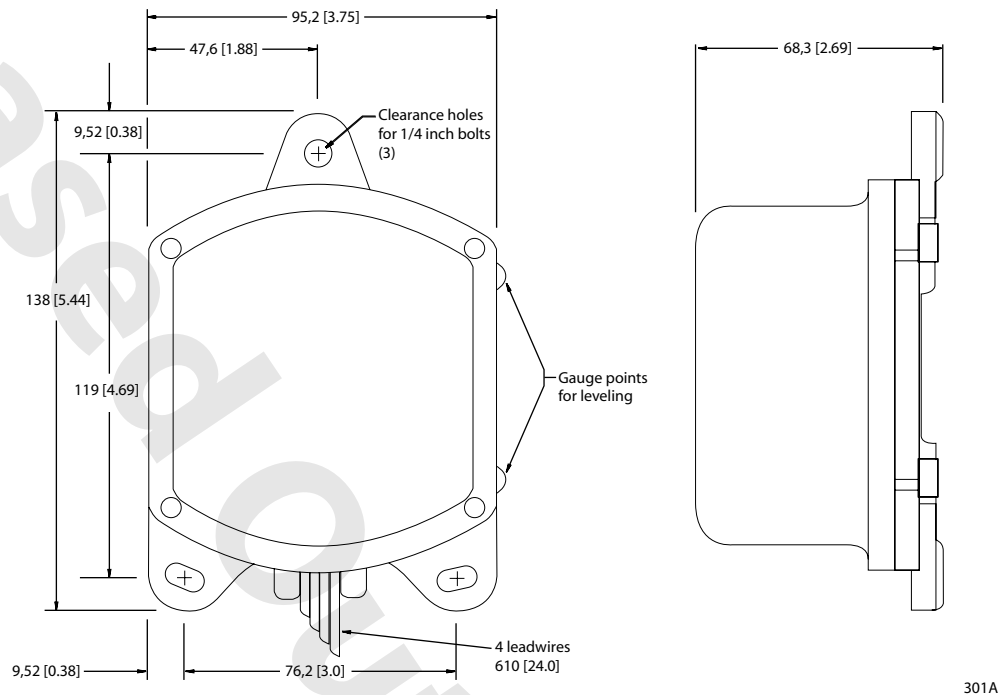

TECHNICAL DATA
Electrical data

Input voltage	
11 to 15 V DC for 12 V models	22 to 30 V DC for 24 V models
Voltage drop	
2.3 V DC (A models)	2.5 V DC (D models)
Load current	
4 A maximum	
Time delay	
¼ and ½ second turn on delays typical on ACW112D. See <i>part number quick reference</i> , page 5.	
Average short circuit current (ACW112D only)	
0.7 A maximum with 0.5 ohm maximum from output to ground	
Standard setpoints	
Fixed ±1°, ±1½°, and ±4¾° models available. Consult Sauer-Danfoss for other options.	
Differential	
Typically less than ½°, turn on to turn off.	

Environmental data

Vibration
Withstands a vibration test designed for mobile equipment controls that includes two parts: <ol style="list-style-type: none"> Cycling from 2 to 2000 Hz over a range of ±1.5 to ±3.0 Gs for a period of one hour (if there are four resonant points), for two hours (if there are two or three resonant points) and for three hours (if there is one or no resonant point). Cycling test performed on each of the three major axes. Resonance dwell for one million cycles over a range of ±1.5 to ±3.0 Gs for each of the four most severe resonant points on each of the three major axes.
Shock
50 Gs for 11 milliseconds. Three shocks in both directions of the three major axes, totaling 18.
Operating temperature
-18 to +60° C (0 to 140° F). The ACW112 will operate from -40 to +66° C (-40 to +150° F) with more liberal specifications.
Storage temperature
-40 to +77° C (-40 to +170° F)
Weight
3 lb 1 oz (1.4 kg)

THEORY OF OPERATION

The ACW112 houses a pendulum suspended from two ball bearings on a horizontal fixed shaft. The pendulum acts as the system's gravity reference for vertical. Four permanent magnets assembled in an arc on the lower portion of the pendulum activate two solid state Hall effect switches.

At level

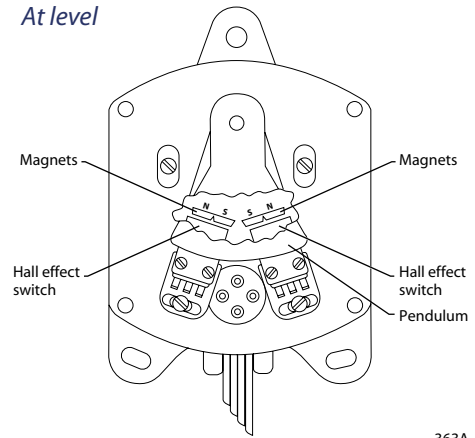

When leveled, both switches are OFF. When the unit is tilted to the right the pendulum rotates such that the right switch is ON and the left switch is OFF. A diode interlock circuit allows an external manual switch to override the controller.

Off level

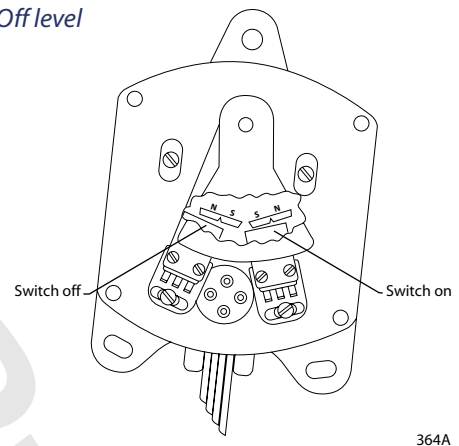

When short circuit current reaches 5 amps in the D model, a current sensor turns the power OFF. A short time delay follows until ON again and the cycle repeats. The internal components are kept from burning because the ratio of time ON to time OFF is low.

INSTALLATION AND ADJUSTMENTS

Installation

Mounting

Before tightening down the mounting screws, the controller must be leveled. Ensure that the machine is level. Use washers on the screws to make leveling easier. Place a small bubble level against the gauge points on the right side edge of the base. Tighten the mounting screws firmly after the controller is level.

Wiring

A suggested wiring scheme is given utilizing a power switch, JOG switch and a fuse. These are additional, optional components and are not supplied with the ACW112 Level Controller.

Connection diagram. Typical wiring to the ACW112.

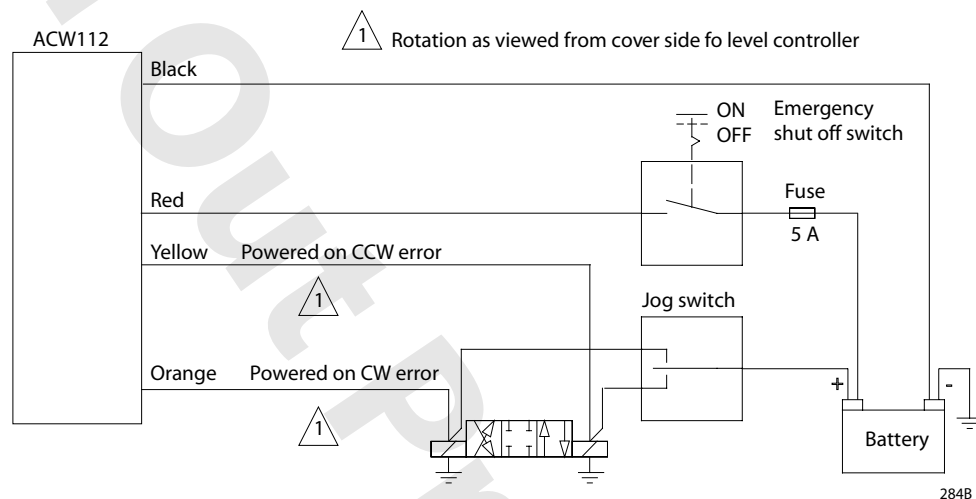

Caution

Be sure the **black** lead wire is grounded to the machine frame (minus side of the electrical system). A poor ground connection will damage the controller.

**INSTALLATION AND
ADJUSTMENTS
(continued)**
Adjustments

The turn-on points of the Level Controller are factory set to order specification. Field adjustment is not recommended. However, in new applications, it may be necessary to change the setting for a particular type of machine. Should the turn-on points need adjustment, use the following procedure.

1. Turn power OFF and remove the ACW112 from the machine. Wipe off as much dirt as possible, particularly from the gasket edge. The controller contains 200 CCS damping fluid and care must be exercised when removing the cover to retain this fluid. The fluid can be captured in the cover when the controller is taken apart by positioning the controller with the cover down while removing the cover screws. Separate the base assembly from the cover and allow most of the oil to drain off.
2. Measure the distance from the edge of the right blade to its mounting base and record the dimension. Loosen the right blade locking screw. To **widen** the turn on point, adjust the right blade **outward**. A change in the right blade position to its mounting base of .048 inch will change the switch point a total of 1°. Changes of less than ½° are not recommended.
3. Hold the blade in its new position and tighten the blade locking screw.
4. Hold the base assembly upright and rotate it side to side to be sure that the pendulum swings freely. Some stickiness due to the oil will be observed when the pendulum touches the stop post.
5. Place the base assembly on the cover and install the cover screws. Mount the control on the machine and check for proper operation.

Internal assembly with adjustment scale

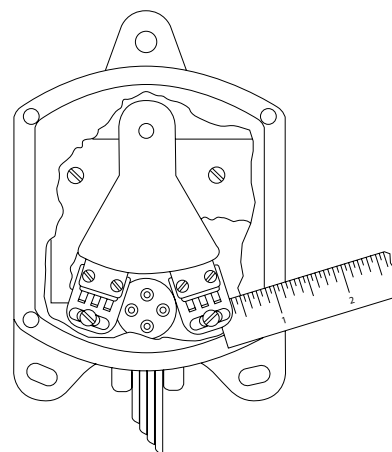

365

It should be noted that this adjustment procedure is for the right blade; for small setting changes, the right blade only needs to be changed. Assume that the controller initially was factory adjusted to give switch turn on points of $\pm 1\frac{1}{2}^\circ$ setting with an additional $\pm 1\frac{1}{2}^\circ$ added to this for a total of 2° switch turn on points. In the example just given, since the right blade only was moved, it will be necessary to mount the controller ½° off the vertical on the machine in order to maintain the same level position that was established prior to the switch change.

Phased Out Products



Products we offer:

- Bent Axis Motors
- Closed Circuit Axial Piston Pumps and Motors
- Displays
- Electrohydraulic Power Steering
- Electrohydraulics
- Hydraulic Power Steering
- Integrated Systems
- Joysticks and Control Handles
- Microcontrollers and Software
- Open Circuit Axial Piston Pumps
- Orbital Motors
- PLUS+1® GUIDE
- Proportional Valves
- Sensors
- Steering
- Transit Mixer Drives

Danfoss Power Solutions is a global manufacturer and supplier of high-quality hydraulic and electronic components. We specialize in providing state-of-the-art technology and solutions that excel in the harsh operating conditions of the mobile off-highway market. Building on our extensive applications expertise, we work closely with our customers to ensure exceptional performance for a broad range of off-highway vehicles.

We help OEMs around the world speed up system development, reduce costs and bring vehicles to market faster.

Danfoss – Your Strongest Partner in Mobile Hydraulics.

Go to www.powersolutions.danfoss.com for further product information.

Wherever off-highway vehicles are at work, so is Danfoss.

We offer expert worldwide support for our customers, ensuring the best possible solutions for outstanding performance. And with an extensive network of Global Service Partners, we also provide comprehensive global service for all of our components.

Please contact the Danfoss Power Solution representative nearest you.

Comatrol

www.comatrol.com

Schwarzmueller-Inverter

www.schwarzmueller-inverter.com

Turolla

www.turollaocg.com

Valmova

www.valmova.com

Hydro-Gear

www.hydro-gear.com

Daikin-Sauer-Danfoss

www.daikin-sauer-danfoss.com

Local address:

Danfoss Power Solutions US Company
2800 East 13th Street
Ames, IA 50010, USA
Phone: +1 515 239 6000

Danfoss Power Solutions GmbH & Co. OHG
Krokamp 35
D-24539 Neumünster, Germany
Phone: +49 4321 871 0

Danfoss Power Solutions ApS
Nordborgvej 81
DK-6430 Nordborg, Denmark
Phone: +45 7488 4444

Danfoss Power Solutions
22F, Block C, Yishan Rd
Shanghai 200233, China
Phone: +86 21 3418 5200

Danfoss can accept no responsibility for possible errors in catalogues, brochures and other printed material. Danfoss reserves the right to alter its products without notice. This also applies to products already on order provided that such alterations can be made without consequential changes being necessary in specifications already agreed. All trademarks in this material are property of the respective companies. Danfoss and the Danfoss logotype are trademarks of Danfoss A/S. All rights reserved.