

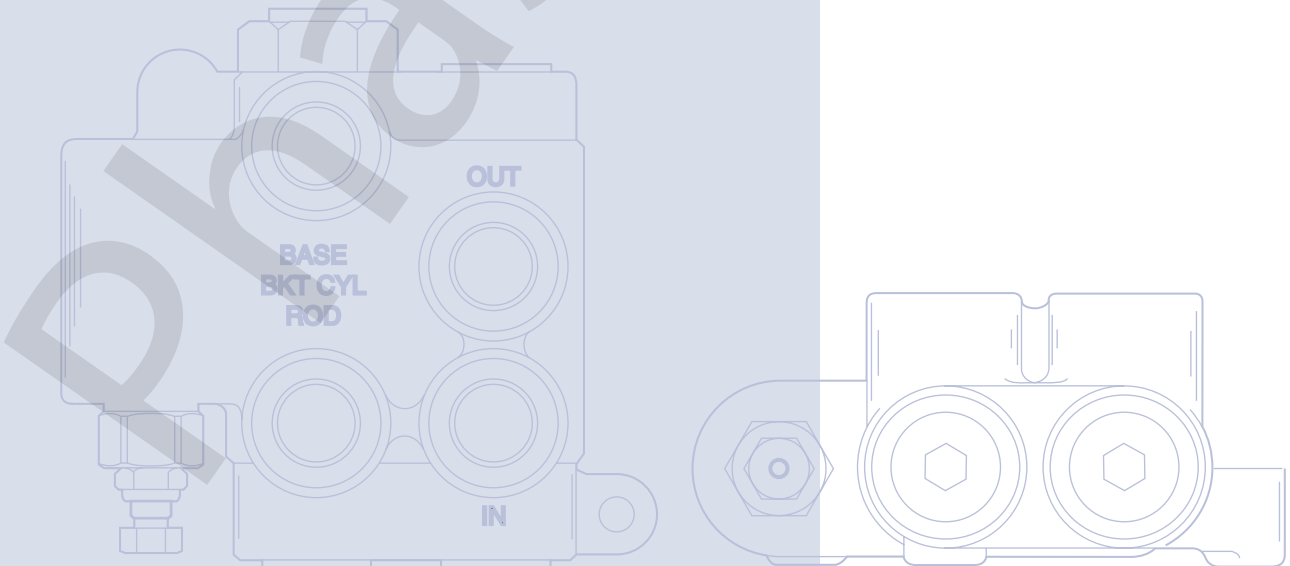

Directional Control
Valve
Model 1480

Technical
Information



HISTORY OF REVISIONS

Table of Revisions

Date	Page	Changed	Rev.
May 2008	-	first edition	AA

© 2008 Sauer-Danfoss. All rights reserved.

Sauer-Danfoss accepts no responsibility for possible errors in catalogs, brochures and other printed material. Sauer-Danfoss reserves the right to alter its products without prior notice. This also applies to products already ordered provided that such alterations aren't in conflict with agreed specifications. All trademarks in this material are properties of their respective owners. Sauer-Danfoss and the Sauer-Danfoss logotype are trademarks of the Sauer-Danfoss Group.

GENERAL INFORMATION	Overview	4
	Design	4
	Typical applications	4
	High performance	4
	Latest technology	4
	Reliability	4
	System diagram	5
	Schematic.....	6
TECHNICAL SPECIFICATIONS	Specifications.....	7
ORIFICE OPTIONS	Orifice options.....	8
INSTALLATION DRAWINGS	Dimensions and ports	9

Phased Out

OVERVIEW

Model 1480 valve is a bucket-leveling control valve. It is designed to work in tandem with other Sauer-Danfoss directional control valves on loader applications. As the bucket is raised the 1480 regulates the flow to the bucket cylinder to keep the bucket level. This minimizes spillage due to rotation of the bucket as the load is raised.

DESIGN**High performance**

- Maximum pressure 205 bar [3000 psi]
- Flow rating 76 l/min [20 US gal/min]
- Tank line maximum pressure 70 bar [1000 psi]
- Cast iron body
- Chrome plated spools select-fit to body

Latest technology

- Customer-driven using quality function deployment (QFD) and design for manufacturability (DFM) techniques
- Computer-modeled castings to optimize performance
- Compact package size minimizes installation space requirements

Reliability

- Designed to rigorous standards
- Proven in both laboratory and field
- Manufactured to rigid quality standards
- Long service life

TYPICAL APPLICATIONS

- Loaders
- Skid-steer loaders
- Loader attachments

SYSTEM DIAGRAM

As the bucket is raised, the 1480 valve receives fluid from the rod end of the lift cylinder. This fluid is divided to divert the correct volume of oil to the base end of the bucket cylinder. Simultaneously, a metering valve incorporated into the 1480 vents oil from rod end port of the bucket cylinder, keeping the bucket level. Internal orifices are sized to match each machine's cylinder sizes and geometry.

Pictorial circuit diagram

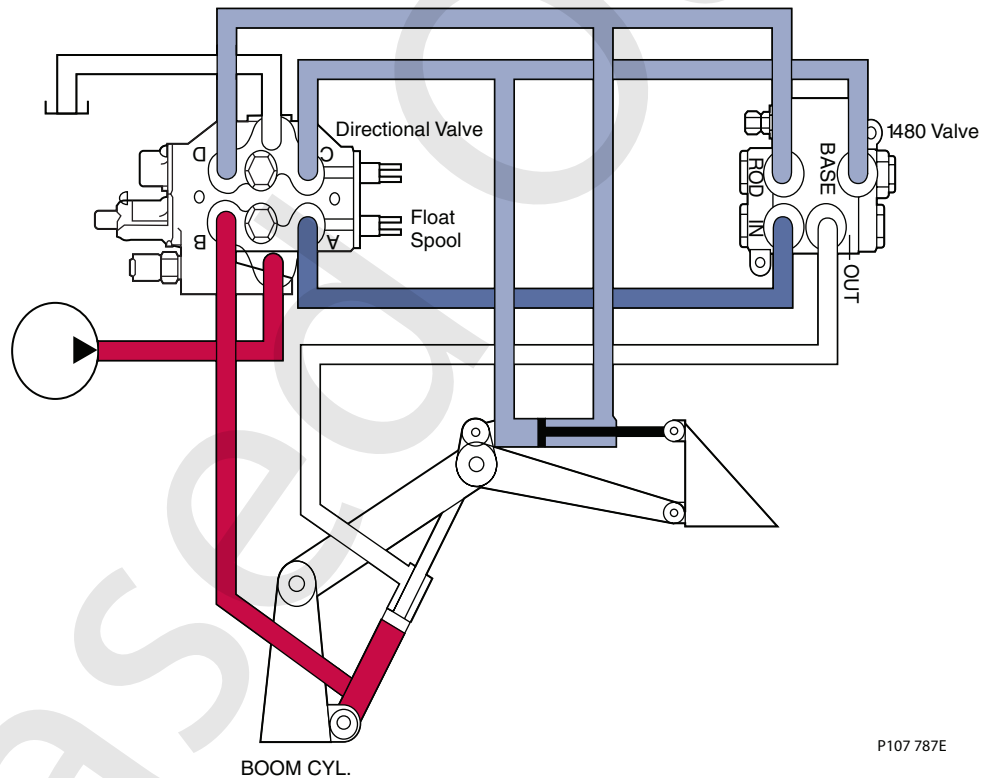

P107 787E

DIAGRAM

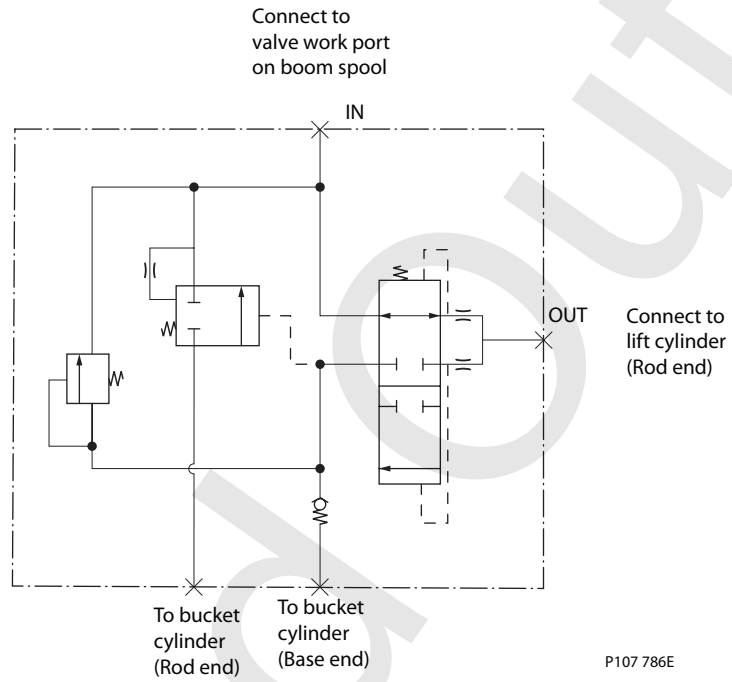

SPECIFICATIONS

Maximum pressure	205 bar [3000 psi]
Maximum tank line pressure	70 bar [1000 psi]
Maximum oil flow	76 l/min [20 US gal/min]
Maximum port leakage at 69 bar [1000 psi] and 21 cSt [102 SUS]	20 cm ³ [1.22 in ³]
Minimum oil temperature	-29°C [-20° F]
Maximum oil temperature	82°C [180°F]
Ambient temperature range	-29°C to 60°C [-20°F to 140°F]
Minimum viscosity	6 cSt [45 SUS]
Maximum viscosity	440 cSt [2000 SUS]
Filtration (maximum contamination) per ISO 4406	19/16

Phased

ORIFICE OPTIONS

When ordering, provide your Sauer-Danfoss representative with the information below.

Orifice sizing information

Input	Figure	Units
Maximum system flow		gpm
Maximum bucket rollback at ground (measured from horizontal)	Angle 1	degrees
Maximum bucket rollback at fully raised (measured from horizontal)	Angle 2	degrees
Maximum dump angle at fully raised (measured from horizontal)	Angle 3	degrees
Lift cylinder piston diameter		inches
Lift cylinder rod diameter		inches
Lift cylinder stroke		inches
Number of lift cylinders		cylinders
Bucket cylinder piston diameter		inches
Bucket cylinder rod diameter		inches
Bucket cylinder stroke		inches
Number of bucket cylinders		cylinders

Bucket geometry

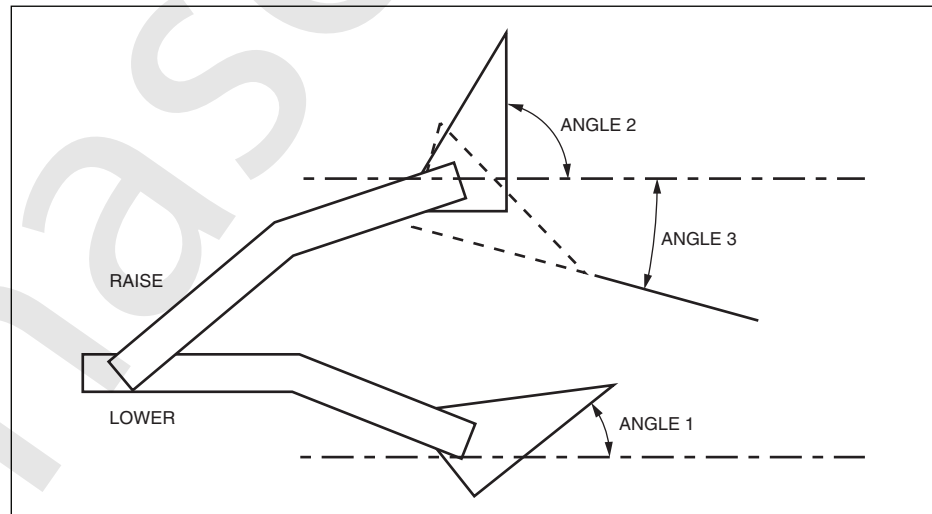

P107 794E

DIMENSIONS AND PORTS

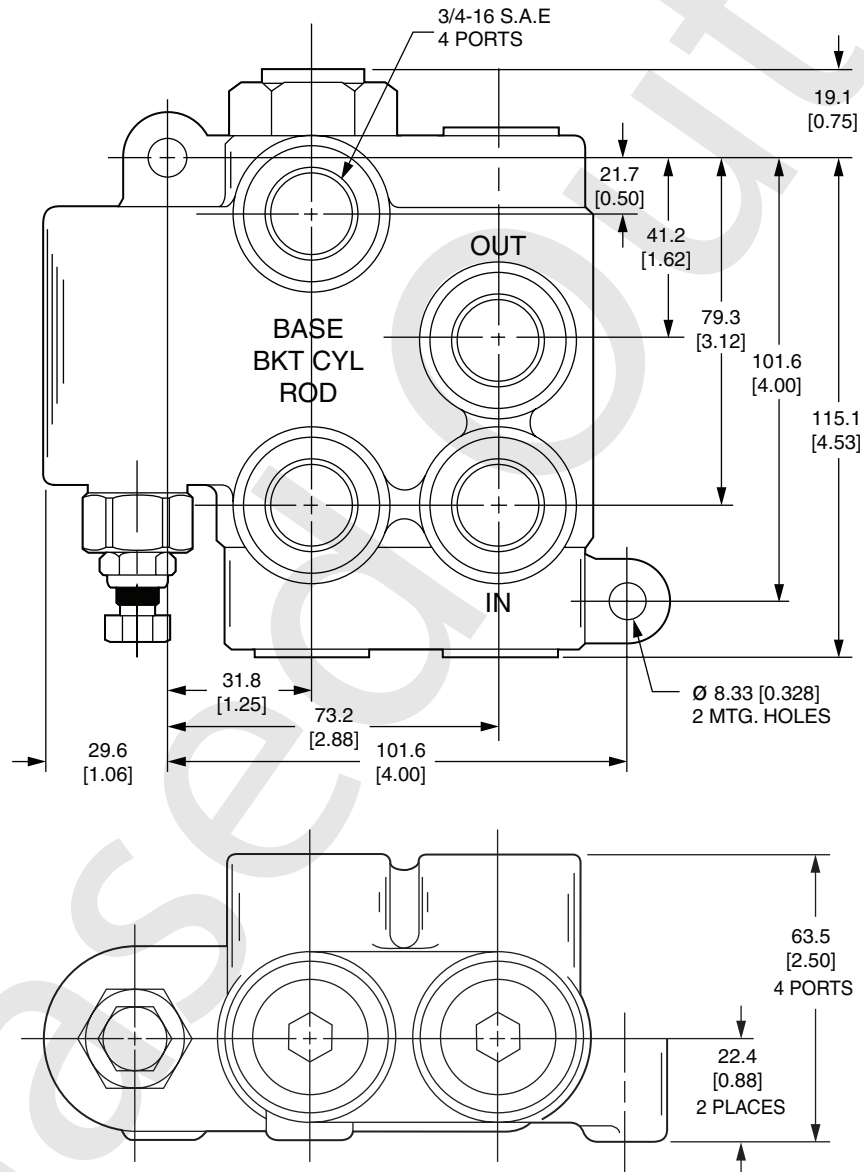

Dimensions mm [inches]

P107 793E

Phased Out

Phased Out

OUR PRODUCTS

Hydrostatic transmissions
Hydraulic power steering
Electric power steering
Electrohydraulic power steering
Closed and open circuit axial piston pumps and motors
Gear pumps and motors
Bent axis motors
Orbital motors
Transit mixer drives
Proportional valves
Directional spool valves
Cartridge valves
Hydraulic integrated circuits
Hydrostatic transaxles
Integrated systems
Fan drive systems
Electrohydraulics
Microcontrollers and software
Electric motors and inverters
Joysticks and control handles
Displays
Sensors

Sauer-Danfoss Mobile Power and Control Systems – Market Leaders Worldwide

Sauer-Danfoss is a comprehensive supplier providing complete systems to the global mobile market.

Sauer-Danfoss serves markets such as agriculture, construction, road building, material handling, municipal, forestry, turf care, and many others.

We offer our customers optimum solutions for their needs and develop new products and systems in close cooperation and partnership with them.

Sauer-Danfoss specializes in integrating a full range of system components to provide vehicle designers with the most advanced total system design.

Sauer-Danfoss provides comprehensive worldwide service for its products through an extensive network of Global Service Partners strategically located in all parts of the world.

Local address:

Sauer-Danfoss (US) Company
2800 East 13th Street
Ames, IA 50010, USA
Phone: +1 515 239-6000
Fax: +1 515 239-6618

Sauer-Danfoss GmbH & Co. OHG
Postfach 2460, D-24531 Neumünster
Krokamp 35, D-24539 Neumünster, Germany
Phone: +49 4321 871-0
Fax: +49 4321 871 122

Sauer-Danfoss ApS
DK-6430 Nordborg, Denmark
Phone: +45 7488 4444
Fax: +45 7488 4400

Sauer-Danfoss-Daikin LTD
Sannomiya Grand Bldg. 8F
2-2-21 Isogami-dori, Chuo-ku
Kobe, Hyogo 651-0086, Japan
Phone: +81 78 231 5001
Fax: +81 78 231 5004