

ENGINEERING  
TOMORROW



Technical Information

# SC0XX-0XX Family

## PLUS+1<sup>®</sup> Safety Controllers



**Revision history**
*Table of revisions*

<b>Date</b>	<b>Changed</b>	<b>Rev</b>
October 2019	Minor correction	0904
October 2019	Corrected table Danfoss crimp extraction tool part information, last row, Description: Extraction tool DEUTSCH 0411-240-2005; 16 to 20, 20 to 24 AW.	0903
July 2019	PWMOUT/DOOUT topic update.	0902
January 2019	Replaced the FRAM memory topic with EEPROM write/erase ratings topic	0901
November 2018	Corrected C1p20 to C1p18 under Product ratings/Lower power mode/condition will wake up the controller/SC050-020	0801
February 2017	for next literature revision: Fixed for content reuse	0702
September 2016	Updated Recommended torque for the DEUTSCH mating connector retaining fastner on 50 pin connectors to 2.26 N•m (20 lb•in).	0701
June 2016	Updated Digital/Analog/Resistance/4-20 mA Current (DIN/AIN/ResIN/CrntIN) Specifications	0601
April 2016	Updated to Engineering Tomorrow design	0501
January 2015	Minor update	FB
May 2014	Converted to Danfoss layout-DITA CMS; Various updates	FA
September 2013	Added LED information and secondary controller information	EA
September 2013	Updated layout	DA
March 2013	SC050-020 input condition	CA
November 2012	Various updates	BA
July 2012	First edition	AA

## Contents

### SC0XX-0XX Safety Controller Family literature references

Technical Information (TI).....	4
Module product Data Sheet (DS).....	4
API specifications (API).....	4
PLUS+1® GUIDE User Manual.....	4

### User liability and safety statements

OEM responsibility.....	6
-------------------------	---

### Overview

SC0XX-0XX Controller Family.....	7
----------------------------------	---

### Inputs/outputs types and specifications

Input types.....	8
DIN/AIN, A/D Refresh Rates.....	8
DIN/AIN/FreqIN.....	9
DIN/AIN/ResIN/CrntIN.....	10
Output types.....	12
DOUT.....	12
PWMOUT/DOUT.....	13
LEDs.....	14

### Controller Area Network (CAN)

CAN system design.....	15
Specifications for terminating resistor.....	15
Notes on CAN Bus installation.....	15
Expansion module CAN Bus loading.....	15
Internal processor-to-processor UART.....	16

### Product ratings

Power.....	17
Module supply voltage/maximum current ratings.....	17
Sensor power supply ratings.....	17
Lower power mode.....	18
Conditions to wake up SC0XX-0XX.....	18
Lower power mode specifications.....	18
Lower power mode current consumption.....	18
EEPROM write/erase ratings.....	19
SC Controller general ratings.....	19
Environmental testing criteria.....	19
Modules housing.....	20

### Product installation and start-up

Connectors.....	21
Mounting.....	21
Machine diagnostic connector.....	22
Grounding.....	22
Hot plugging.....	22
PLUS+1® USB/CAN Gateway.....	22
Machine wiring guidelines.....	23
Machine welding guidelines.....	23

## SC0XX-0XX Safety Controller Family literature references

### Reference literature

Literature title	Literature type	Literature number
PLUS+1® SC0XX-0XX Controller Family	Technical Information	<b>L1026334</b>
PLUS+1® Safety Controllers SC024-010 and SC024-012	Data Sheet	<b>L1109626</b>
PLUS+1® Safety Controllers SC024-020 and SC024-022	Data Sheet	<b>L1109925</b>
PLUS+1® Safety Controllers SC050-020 and SC024-022	Data Sheet	<b>L1109598</b>
PLUS+1® GUIDE Software	User Manual	<b>10100824</b>

[Comprehensive technical literature is online at www.danfoss.com](http://www.danfoss.com)

---

### Technical Information (TI)

A TI is comprehensive information for engineering and service personnel to reference.

### Module product Data Sheet (DS)

A module product DS contains summarized information and parameters that are unique to an individual PLUS+1® module, including:

- Numbers and types of inputs and outputs
- Module connector pin assignments
- Module maximum current capacity
- Module sensor power supply (if present) current capacity
- Module installation drawing
- Module weights
- Product ordering information

### API specifications (API)

Module API specifications contain detailed information about the module BIOS. PLUS+1® BIOS functionality is pin dependent. Pins are defined in module data sheets as C (connector number) p (pin number).

API specifications include:

- Variable name
- Variable data type
- Variable direction (read/write)
- Variable function and scaling

[Module API specifications are the definitive source of information regarding PLUS+1® module pin characteristics.](#)

---

### PLUS+1® GUIDE User Manual

The Operation Manual (OM) details information regarding the PLUS+1® GUIDE tool used in building PLUS+1® applications. This OM covers the following broad topics:

### **SC0XX-0XX Safety Controller Family literature references**

- How to use the PLUS+1® GUIDE graphical application development tool to create machine applications
- How to configure module input and output parameters
- How to download PLUS+1® GUIDE applications to target PLUS+1® hardware modules
- How to upload and download tuning parameters
- How to use the PLUS+1® Service Tool

**User liability and safety statements****OEM responsibility**

The OEM of a machine or vehicle in which Danfoss products are installed has the full responsibility for all consequences that might occur. Danfoss has no responsibility for any consequences, direct or indirect, caused by failures or malfunctions.

- Danfoss has no responsibility for any accidents caused by incorrectly mounted or maintained equipment.
- Danfoss does not assume any responsibility for Danfoss products being incorrectly applied or the system being programmed in a manner that jeopardizes safety.
- All safety critical systems shall include an emergency stop to switch off the main supply voltage for the outputs of the electronic control system. All safety critical components shall be installed in such a way that the main supply voltage can be switched off at any time. The emergency stop must be easily accessible to the operator.

## Overview

### SC0XX-0XX Controller Family

*24 and 50 Pin SC0XX-0XX Controllers*

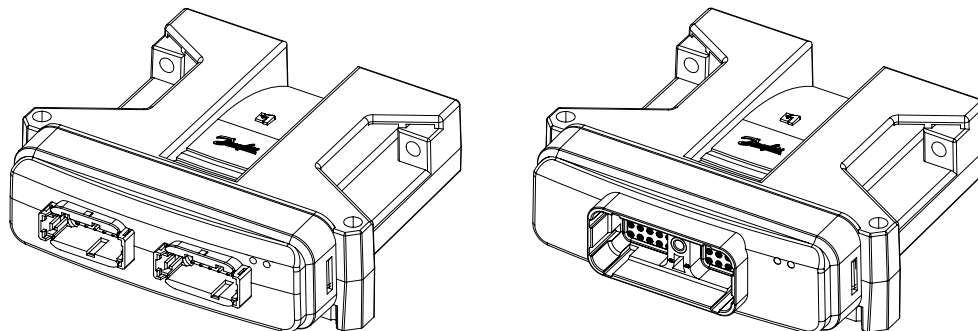

P200147

---

[The SC0XX-0XX Controller Family comes in the same sized blue housing.](#)

---

These modules communicate with one another and other intelligent systems over a machine Controller Area Network (CAN) data bus.

PLUS+1® Mobile Machine Modules are designed to provide flexible, expandable, powerful and cost effective total machine management systems for a wide variety of vehicle applications.

PLUS+1® controller products utilize modular designs wherever possible. This modularity extends to product housings, connectors and control circuitry.

PLUS+1® hardware products are designed to be equally effective in a distributed CAN system, with intelligence in every node, or as stand-alone control for smaller machine systems.

PLUS+1® Compliant systems are incrementally expandable: additional modules can be easily added to the machine CAN bus to increase system capabilities or computational power.

## Inputs/outputs types and specifications

PLUS+1® modules have input or output pins that support multiple functions. Pins that support multiple input or output types are user-configurable using PLUS+1® GUIDE software. Refer to product data sheets for the input/output (I/O) content of individual modules.

### Input types

- Digital or Analog (DIN/AIN)
- Analog Input Offset
- A/D Refresh Rate
- Digital/Analog/Frequency (DIN/AIN/FreqIN)
- Digital/Analog/Resistance/4-20 mA Current (DIN/AIN/ResIN/CrntIN)
- Digital/Analog/1.6 Vdc Sensor Power (DIN/AIN/SnsrPwr1.6Vdc)
- Digital/Analog/3.6 Vdc Sensor Power (DIN/AIN/SnsrPwr3.6Vdc)

Each PLUS+1® module input pin supports one of the above functional types. For pins with multiple functions, input configurations are user programmable using PLUS+1® GUIDE templates.

### DIN/AIN, A/D Refresh Rates

Multifunction pins that are configured to be Digital input (DIN) are subject to the same update rates as the Analog input (AIN) function for that pin. Debounce is not used, as hysteresis is built into the function. The time to recognize a transition is dependent on the timing of the switch activation and the sample rate.

#### General response to input time

Description	Comment
Response to input below minimum voltage	Non-damaging, non-latching; reading saturates to the low limit.
Response to input above maximum voltage	Non-damaging, non-latching; reading saturates to the high limit.
Response to input open	Pin configuration dependent: No pull up/ no pull down = floating Pull up to 5 Vdc = 5 Vdc Pull down = 0 Vdc Pull up/ pull down = 2.5 Vdc
Voltage working ranges	Programmable (see specific data sheets for ranges).

#### Digital/Analog Inputs (DIN/AIN)

Description	Units	Minimum	Maximum	Comment
Allowed voltage at pin	Vdc	0	36	— —
Maximum discernible voltage (high range)	Vdc	34.10	36.5	35.3 Vdc is typical.
Minimum discernible voltage (high range)	mV	0	130	— —
Maximum discernible voltage (middle range)	Vdc	5.13	5.38	5.26 Vdc is typical.
Minimum discernible voltage (low range)	mV	0	20	— —
Precision (high range)	mV	— —	9	— —
Worst case error (high range)	Vdc	— —	1.16	— —
Precision (middle range)	mV	— —	1.3	— —
Worst case error (middle range)	mV	— —	120	— —
Input impedance (pulled up to 5 Vdc or ground, middle range)	kΩ	13.9	14.3	— —
Input impedance (pulled up to 2.5 Vdc middle range)	kΩ	7.2	7.4	— —
Input impedance (no pull ups, middle range)	kΩ	230	236	— —
Input impedance (pulled up to 5 Vdc or ground, high range)	kΩ	13.0	13.4	— —



## Inputs/outputs types and specifications

### Digital/Analog Inputs (DIN/AIN) (continued)

Description	Units	Minimum	Maximum	Comment
Input impedance (pulled up to 2.5 Vdc high range)	kΩ	6.9	7.1	-- --
Input impedance (no pull ups, high range)	kΩ	108	112	-- --

### A/D refresh rates for SC0XX-0XX Controllers

SC Controller	A/D refresh rate
SC024-010/012	All: 1.0 ms
SC024-020/022	All: 1.0 ms
SC050-020/022	All: 1.0 ms

### DIN/AIN/FreqIN

The characteristics of Digital/Analog/Frequency (DIN/AIN/FreqIN) pins are PLUS+1® GUIDE software controlled. The input can be digital, analog or frequency.

Inputs can be pulled to 5 Vdc, pulled to ground, pulled to 2.5 Vdc, or no pull-up/pull-down.

### DIN/AIN/FreqIN general information

Description	Comment
Response to input below minimum voltage	Non-damaging, non-latching; reading saturates to the low limit.
Response to input above maximum voltage	Non-damaging, non-latching; reading saturates to the high limit.
Expected measurement	Frequency (Hz)
	Period (0.1 μsec)
	Channel to channel phase shift (paired inputs . . .) (0.1 ms).
	PWM duty cycle (0.01%)—Duty cycle measurement only valid up to 5 kHz (FreqIN).
	Edge count.
Quadrature count (paired inputs driven from a quadrature encoder).	
Pull up/pull down configuration	No pull down/ pull up is standard with pull up or pull down programmable; failure modes are detectable.

### DIN/AIN/FreqIN characteristics

Description	Units	Minimum	Maximum	Comment
Allowed voltage at pin	Vdc	0	36	
Frequency range	Hz	0	10,000	In steps of 1 Hz.
Frequency input when used as quad count or phase shift	Hz	0	5000	In steps of 1 Hz.
Maximum discernible voltage (high range)	Vdc	34.1	36.5	35.3 Vdc is typical.
Minimum discernible voltage (high range)	mV	0	130	
Maximum discernible voltage (middle range)	Vdc	5.13	5.38	5.26 Vdc is typical.
Minimum discernible voltage (middle range)	mV	0	20	
Maximum discernible voltage (low range)	Vdc	0.341	0.395	0.368 Vdc is typical.
Minimum discernible voltage (low range)	mV	0	12.9	
Precision (high range)	mV	--	9	
Worst case error (high range)	Vdc	--	1.16	
Precision (middle range)	mV	--	1.3	
Worst case error (middle range)	mV	--	120	
Precision (low range)	μV	--	90	
Worst case error (low range)	mV	--	27	

## Inputs/outputs types and specifications

### DIN/AIN/FreqIN characteristics (continued)

Description	Units	Minimum	Maximum	Comment
Input impedance (pulled to 5 Vdc or ground, low range)	kΩ	13.9	14.3	
Input impedance (pulled to 2.5 Vdc, low range)	kΩ	7.2	7.4	
Input impedance (no pull ups, low range)	kΩ	230	236	
Input impedance (pulled to 5 Vdc or ground, middle range)	kΩ	13.9	14.3	
Input impedance (pulled to 2.5 Vdc middle range)	kΩ	7.2	7.4	
Input impedance (no pull ups, middle range)	kΩ	230	236	
Input impedance (pulled to 5 Vdc or ground, high range)	kΩ	13	13.4	
Input impedance (pulled to 2.5 Vdc high range)	kΩ	6.9	7.1	
Input impedance (no pull ups, high range)	kΩ	108	112	

This table shows the rising and falling thresholds when the input is used as a frequency input.

### Rising and falling thresholds for frequency input

Description	Units	Minimum	Maximum	Comment
Rising voltage threshold (high range)	Vdc	11.83	26.55	Voltage required for frequency input to read high.
Falling voltage threshold (high range)	Vdc	5.61	18.89	Voltage required for frequency input to read low.
Rising voltage threshold (middle range)	Vdc	1.78	3.92	Voltage required for frequency input to read high.
Falling voltage threshold (middle range)	Vdc	0.84	2.79	Voltage required for frequency input to read low.
Rising voltage threshold (low range)	Vdc	0.11	0.30	Voltage required for frequency input to read high.
Falling voltage threshold (low range)	Vdc	0.04	0.22	Voltage required for frequency input to read low.

Potential for IX modules to not go online. If voltage is applied to an IX module input pin prior to the module being powered on, there is a possibility that the module CPU will not power up. The module is not damaged and will power up and operate normally once power is removed from the input pins. It is recommended that either the IX module's 5 Vdc sensor power be used to power sensors or that power is removed from the input pins until the module is powered up.

If the frequency goes to zero, the data will not decay over time, it will be updated once a new pulse is seen, or times out. It is possible to monitor the count of pulses to know when the frequency reading is updated.

### DIN/AIN/ResIN/CrntIN

Digital/Analog/Resistance/4-20 mA Current (DIN/AIN/ResIN/CrntIN). When a module input pin is configured as a resistance/rheostat/temp sensor input, the device will provide up to 3.76 mA current to an external load (RL) which then can be measured. The equation for relating AD counts to a given load is:  $AD\ counts = (30996 * RL) / (RL + 1322)$ . This calculation is solved internally and the ohms value is available for the programmer. The following Rheostat inputs chart shows the relationship between AD counts and load resistance in ohms.

## Inputs/outputs types and specifications

Rheostat inputs chart

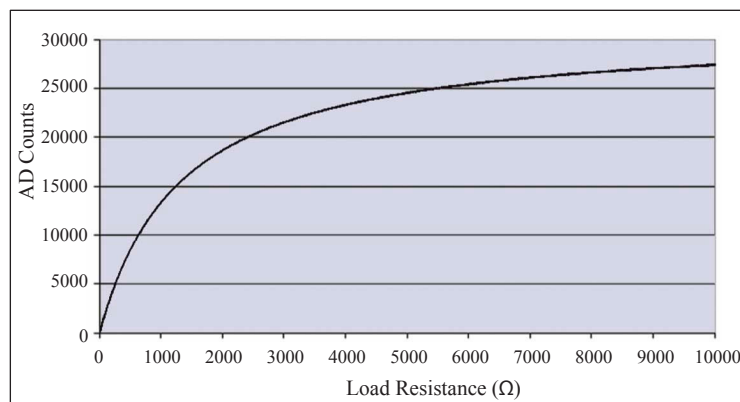

P200 083

### Input type characteristics

Description	Units	Minimum	Maximum	Comment
Allowed voltage at pin	Vdc	0	36	
Measured resistance	Ω	0	10,000	
Minimum discernible current	mA	0	0.1	
Maximum discernible current	mA	25.3	27	
Precision	μA		6	
Worst case error	μA		868	Over the full temperature range -40°C to 85°C (-40°F to 185°F)
Input impedance	Ω	198.6	202.6	
Maximum over-current protection time at start up (current ≥ 24 mA)	ms		100	
Recover time after over-current protection	s	5.4		
Maximum discernible voltage (high range)	Vdc	25.3		
Minimum discernible voltage (high range)	mV	0	130	
Precision (high range)	mV		9	
Worst case error (high range)	Vdc		1.16	Over the full temperature range -40°C to 85°C (-40°F to 185°F)
Maximum discernible voltage (middle range)	Vdc	5.13	5.38	
Minimum discernible voltage (middle range)	mV	0	20	
Precision (middle range)	mV		1.3	
Worst case error	mV		120	Over the full temperature range -40°C to 85°C (-40°F to 185°F)
Input impedance (pulled to 5 Vdc or ground high range)	KΩ	13.0	13.4	
Input impedance (pulled to 2.5 Vdc high range)	KΩ	6.9	7.1	
Input impedance (no pull ups high range)	KΩ	108	112	
Input impedance (pulled to 5 Vdc or ground middle range)	KΩ	13.9	14.3	
Input impedance (pulled to 2.5 Vdc middle range)	KΩ	7.2	7.4	
Input impedance (no pull ups middle range)	KΩ	230	236	

## Inputs/outputs types and specifications

### Output types

SC0XX-0XX available output types.

- Digital (DOUT)
- Pulse Width Modulated (PWM/DOUT/PVGOUT)

*Output pins available on SC0XX-0XX Controller Family*

SC Controller	DOUT (3 A)	PWMOUT/DOUT/(3 A)
SC024-010		4
SC024-020		8
SC050-020	6	8

PLUS+1® modules feature user-configurable output pin parameters. Output pin parameters are configured using PLUS+1® GUIDE templates.

Refer to module data sheets for maximum output current ratings of individual modules. The total output current for any PLUS+1® module must not exceed the maximum allowable current specified in the module data sheet.

#### **Warning**

Unintended movement of the machine or mechanism may cause injury to the technician or bystanders. The module will be powered up if battery voltage is applied to the module's output pin. To protect against unintended movement, secure the machine.

#### **Caution**

Warranty will be voided if module is damaged.  
 Avoid significant current driven back through an output pin.

### DOUT

Digital (DOUT) outputs can source up to 3 A.

### General

Description	Comment
Configuration	Sourcing only.
Type	Linear switching.
Short circuit to ground protection	Non-damage, current/thermal limit with status indication; automatic latch off /resume.
Open circuit detection	Fault indication provided. The GUIDE Pin Status requires a load of 0.22 A to be connected or an open fault will be declared.
Parallel operation	Digital outputs from the same module are capable of being connected together such that the net current rating is the sum of the individual ratings; timing is resolved by the operating system; diagnostic capability is maintained.
Shut off	Processor control with hardware WatchDog override.

### Specifications

Description	Units	Minimum	Maximum	Comment
Output voltage, energized state	Vdc	Vbatt-1.0	Vbatt	Over all load conditions.
Output voltage, off state	Vdc	0	0.1	At Rload=200 Ω
Output current range for a status bit to read OK	A	0.22	3	

Do not connect a digital output to battery+ (back drive) without a series diode.

## Inputs/outputs types and specifications

For each digital output there are two switches in series. One switch is controlled and monitored by the secondary controller, and one is controlled and monitored by the primary processor. The secondary controller can monitor the condition of the redundant switch under its control with a digital voltage feedback signal. Any output can be disconnected from its supply voltage at any time by the secondary controller with this redundant switch. When the redundant switch is disabled it must remain disabled by the kernel for 250 milliseconds before the secondary controller's application is allowed to re-enable the redundant switch. When the redundant switch controlled by the secondary controller is enabled then the digital outputs can be enabled/disabled as commanded by the primary processor. The primary processor can monitor the condition of its switch with a digital voltage feedback signal.

### PWMOUT/DOUT

All PLUS+1® module proportional outputs are Pulse Width Modulated (PWM). PWM frequency is software adjustable using PLUS+1® GUIDE. A low frequency dither may also be added with software to some outputs (see individual module API specifications for PWM outputs that support dither). There are two modes of PWM operation: open loop and closed loop (current control).

In open loop mode, current can be sourced or sunk, but the output is a PWM duty cycle. Current feedback may be monitored in open loop mode, but the output is a constant voltage, not a constant current. The signal line of PVG valves can be driven with an open loop PWM. The PWM driving the control signal must be set to 0 at the same time as the digital output driving the PVE power pin is set to 0.

In open loop mode, current can be sourced or sunk (all modules are limited to 8 amps sinking), but the output is a PWM duty cycle. Current feedback may be monitored in open loop mode, but the output is a constant voltage, not a constant current. PVG valves may be driven with open loop PWM.

In closed loop mode, the maximum current is limited by measuring the feedback current. There is no thermal protection. If the maximum current is exceeded, the controller kernel will shut down the output and latch it. The kernel also limits how quickly the output can be repowered (250 ms). The output cannot be reset until the command goes to 0 or False (if configured as a digital output).

Refer to individual module data sheets for the maximum allowable output current for each PLUS+1® module.

#### General

Description	Comment
Configuration	Sourcing or sinking
Type (Linear vs. PWM)	PWM
Operating modes	Programmable: closed loop current or open loop voltage (duty cycle)
Dual coil PCPs	Compensated for induced currents in a non-driven coil (closed loop mode)
Short circuit to ground	Output fully protected against damage and fault detected
Mode selection	Programmable: (current or voltage) and full scale current ranges

Do not connect a digital output to battery+ (back drive) without a series diode.

PLUS+1® PWM output circuits are not designed to be used as inputs. Output current feedback readings should be used for fault checking only.

#### **Warning**

Unintended movement of the machine or mechanism may cause injury to the technician or bystanders. The module will be powered up if battery voltage is applied to the module's output pin. To protect against unintended movement, secure the machine.

#### **Caution**

Warranty will be voided if module is damaged.  
Avoid significant current driven back through an output pin.

## Inputs/outputs types and specifications

### Specifications

Description	Units	Minimum	Maximum	Comment
Full scale proportional current output	mA	10	3000	The current may accidentally be exceeded in open loop mode. If the current exceeds the trip point, the output will be latched off.
Output voltage, 100% duty cycle	Vdc	0	Vbatt-1	
Output resolution of 3 A	mA		0.25	
Repeatability of full range	% of full scale		0.5	
Absolute accuracy of full range	% of full scale		3.0	
Output settling time	ms		100	Depends on load characteristics.
PWM frequency	Hz	33	4000	Some pins have a fixed frequency, consult module application program interface (API).
Dither frequency	Hz	33	250	Increased in steps, see module API.
Dither amplitude	A	0	0.5	Increased in steps, see module API.
Over-current trip point	A	5	5.25	There is over-current protection built into each output driver. If the instantaneous current exceeds the trip point, the driver is latched off. GUIDE application software can reset the latch and attempt to drive current again.

For each PWM output there are two switches in series for sourcing current/voltage (the high-side of the half bridge has two switches). One switch is controlled and monitored by the secondary controller, and the other is controlled and monitored by the primary processor. The secondary controller can monitor the condition of the redundant switch under its control with a digital voltage feedback signal. Each sourcing PWM output can be disconnected from its supply voltage at any time by the secondary controller with this redundant switch. When the redundant switch is disabled it must remain disabled by the kernel for 250 ms before the secondary controller's application is allowed to re-enable the redundant switch. When the switch controlled by the secondary controller is enabled then the PWM outputs are allowed to source current as commanded by the primary processor. The primary processor can monitor the condition of its switch with the analog current feedback measurement.

### LEDs

There are two LEDs on every PLUS+1® module, one red and one green. Both are under application software control of the primary processor. Before the primary processor's application software starts running, the green LED will be on and the red LED will be off.

Each LED light pipe will have an alternate yellow color which the application software will not have access to. These alternate yellow colors will be used to indicate low-level software and/or hardware failures. The yellow LED shared with the green LED light pipe will be controlled by the primary processor, and the yellow LED shared with the red LED light pipe will be controlled by the secondary controller. When either yellow LED is enabled the signal will override its shared green or red LED.

## Controller Area Network (CAN)

There are two channels fully dedicated to CAN communications on the 50 pin hardware. One channel routed to the primary processor only, and the other channel is routed to both the primary and secondary processors.

There is one channel fully dedicated to CAN communications on the 24 pin hardware. This channel is routed to both the primary and secondary processors.

<b>Baud rate</b>	Up to 1 Mbps
<b>Termination</b>	No internal termination

## CAN system design

All PLUS+1® modules have CAN ports that conform to CAN 2.0B specifications, including CAN shield.

### **Warning**

Unintended movement of the machine or mechanism may cause injury to the technician or bystanders. Machine performance may be impaired if CAN communications are disrupted by electrical fields. To prevent potential unintended machine movement and to meet EMC requirements, a shielded CAN bus is recommended.

## Specifications for terminating resistor

Each end of the main backbone of the CAN bus must be terminated with an appropriate resistance to provide correct termination of the CAN\_H and CAN\_L conductors. This termination resistance should be connected between the CAN\_H and CAN\_L conductors.

### Specifications

Description	Units	Minimum	Maximum	Nominal	Comment
Resistance	Ω	110	130	120	Minimum power dissipation 400 mW (assumes a short of 16 Vdc to CAN_H).
Inductance	μH		1		

## Notes on CAN Bus installation

Total bus impedance should be 60 Ω.

The CAN transceiver will be damaged by any voltage outside of allowable range, (-27 to +36 Vdc), even with a very short pulse.

If using shielded cable, the shield must be grounded to the machine ground at one point only; preferably at the mid-point of the CAN bus. Each PLUS+1® module CAN shield pin must be connected to the cable shield.

## Expansion module CAN Bus loading

System designers incorporating PLUS+1® expansion modules in their applications should be aware of PLUS+1® CAN bus loading and controller memory usage during system design. Each expansion module is associated with a PLUS+1® controller and uses part of the controller's memory resources for inter-module communications. The following table can be used to estimate system CAN bus loading and the memory impact of I/O modules on their associated controller.

## Controller Area Network (CAN)

### Estimated usage of memory and communication resources

Description	IX012-010	IX024-010	OX012-010	OX024-010	IOX012-010	IOX024-20
Estimated module bus load (using default update and 250K bus speed)	4%	10%	11%	27%	11%	27%
Estimated module bus load (using 70 ms updates and 250K bus speed)	2%	5%	3%	8%	4%	8%
RAM usage on SC024-010, SC024-020	9%	12%	9%	14%	9%	17%
RAM usage on SC050-020	1%	1%	1%	2%	1%	2%
ROM usage on SC024-010, SC024-020	8%	11%	12%	18%	10%	20%
ROM usage on SC050-020	3%	4%	4%	6%	3%	8%

## Internal processor-to-processor UART

There are two UART channels fully dedicated to diagnostic communication between processors. One channel is dedicated to processor diagnostics, and the other is dedicated to CAN\_1 message send and receive diagnostics.

The hardware and low-level software provide a basic framework for communication on each channel, however the specific data structure is not predefined because the data to be transferred is application dependent.

<b>Baud rate</b>	Up to 7.5 MBps
<b>Termination</b>	N/A

The secondary processor:

- Has access to all inputs including sensor power and battery measurements, PWM output currents, as well as one external CAN channel.
- Can control and check all redundant sourcing output stages.
- Has access to a digital signal indicating that the internal power supplies are within acceptable limits.
- Can communicate application specific data through a dedicated serial bus.
- Has the ability to disable sourcing (disconnect high-side switch) of each output individually in the event that any of these signals indicates there is a fault condition as defined by the application.



## Product ratings

### Power

Battery power must be supplied to designated power-up digital inputs, since the controller's 3 to 12 Vdc regulated power supply is not available when the controller is in lower power mode.

### Module supply voltage/maximum current ratings

PLUS+1® modules are designed to operate with a nominal 7 to 36 Vdc power supply.

The modules will survive with full functionality if the supply voltage remains below 36 Vdc.

### Specifications

Description		Units	Minimum	Maximum	Comment
Allowed voltage at pin		Vdc	0	36	
Allowed module current		A	0		Consult module data sheets for maximum allowable current.
SRon	Minimum voltage rise rate for power turn-on	V/ms	1	—	The voltage applied to the power pins must exceed this value to guarantee the device will power-up.
Ton	Turn-on time	ms	—	250	From applied battery power to application software start.

### ! Caution

PCB damage may occur.

To prevent damage to the module all module power supply + pins must be connected to the vehicle power supply to support advertised module maximum output current capacity. DO NOT use module power supply + pins to supply power to other modules on a machine.

### Sensor power supply ratings

PLUS+1® modules that support sensor inputs are provided with dedicated, software adjustable, regulated sensor power supply and ground pins. Refer to individual product data sheets for sensor power supply current ratings.

#### General

Description	Comment
Short circuit to ground	Output is not damaged and fault is detected.
Short circuit to battery +	Output is not damaged and fault is detected.

### Specifications

Description	Units	Minimum	Maximum	Comment
Output short circuit voltage	Vdc		36	
Sensor output voltage	Vdc	3	12	
Output current	mA	0	500	The maximum power must be limited to 2.5 Watts for Vout greater than 5 Vdc.
Output Load Capacitance	µF		10	
Hold up time after power loss	ms	5	15	

SC0XX-0XX controllers feature two additional levels of regulated power: 1.6 Vdc and 3.3 Vdc. The PLUS+1® GUIDE application developer can detect open and short digital inputs, when these power supplies are used in conjunction with DIN/AIN inputs.

## Product ratings

### Specifications

Description	Units	Minimum	Maximum	Comment
Output short circuit voltage	Vdc		36	
Output voltage, sensors	Vdc	3	12	Sensor power supply drops below minimum if controller power supply is less than 7 Vdc.
Output voltage, DIN diagnostics	Vdc	1.58	1.76	Nominal 1.6
Output voltage, DIN diagnostics	Vdc	3.21	3.45	Nominal 3.3

## Lower power mode

This feature gives OEM designers the ability to implement automotive-like features in their machine control system design. If the lower power mode feature is not implemented, this controller has the same operating characteristics as any other PLUS+1® controller.

When used as a lower power mode controller, supply power to the module is connected directly to the battery. Lower power mode initiation is defined by the controller's application software: PLUS+1® GUIDE programmers define the conditions under which the controller is to be put into lower power mode. When in lower power mode, controller outputs are set to zero, sensor power supply is off and the controller consumes a small amount of current.

### Conditions to wake up SC0XX-0XX

Either of two conditions will wake up the controller:

- The power supplies can be re-energized by cycling battery power.
- Generating a positive/rising edge on one of several inputs:
  - SC024-010: C1p5, C1p6, C1p7, C1p10, C1p11, C1p12, C2p1, C2p7, C2p8
  - SC024-020: C1p5, C1p6, C1p7
  - SC050-020: C1p5, C1p6, C1p7, C1p18, C1p19, C1p23, C1p24, C1p31, C1p32

### Lower power mode specifications

#### Specifications

Description	Units	Minimum	Maximum	Comment	
Power-up pin threshold	Vdc	2	36	To wake up by cycling input power.	
Power-up pin threshold	Vdc	4.5	36	To wake up by digital input.	
Power-up time delay	mSec	250	500		
SRon	Minimum voltage rise rate for power turn-on	V/ms	—	—	The voltage applied to the input pins must exceed this value to guarantee the device will power-up.
Toff	Turn-off time	ms	150	400	From software commanded shutdown to micro reset.

### Lower power mode current consumption

#### Controller lower power mode current consumption

Supply voltage	Lower power mode current consumption
12 Vdc	20 mA
24 Vdc	20 mA

## Product ratings

### EEPROM write/erase ratings

To prevent unexpected memory writes, care must be taken to ensure memory with a high number of read/write cycles is either U32 or S32 data types.

#### Write/erase cycles

Description	Minimum	Maximum	Comment
EEPROM write/erase cycles	1 million		Minimum valid over entire operating temperature range.

EEPROM used in SC0XX-0XX controllers is rated for 1 million read/write cycles per sector. Sector size is 32 bits. When a value is written to EEPROM, all 32 bits in a particular sector are always written, regardless of the size of the saved value. If the value being saved in a sector is less than 32 bits (such as U8, S16, BOOL) adjacent bits in the same EEPROM sector are rewritten with their previous value. The implication of this memory property is that if two values are being written to the same memory sector, the useful life of the sector is determined by the value being written most frequently. If that value exceeds 1 million read/write cycles, all values in the sector may be compromised if the useful life is exceeded.

### SC Controller general ratings

Description	Units	Minimum	Maximum	Comment
Operating temperature	°C [°F]	-40 [-40]	85 [185]	
Storage temperature	°C [°F]	-40 [-40]	85 [185]	
Allowable module supply voltage	Vdc	7	36	
Module sensor supply voltage	Vdc	3	12	Sensor voltage drops below the minimum value if module supply voltage < 7 Vdc. See <a href="#">Sensor power supply ratings</a> on page 17.
Analog input voltage levels	Vdc		36	
Allowable output load current (per pin)	A			See individual module data sheets.
Module allowable total output current	A			See individual module data sheets.
All modules Ingress Protection (IP) rating*				IP 67
All modules CE rating				CE compliant

\* The PLUS+1® modules IP 67 rating is only valid when the module mating connector is in place and unused connector pin positions have sealing plugs installed.

### Environmental testing criteria

#### Climate environment

Description	Applicable standard	Comment
Storage temperature	IEC 60068-2-1, test Ab, IEC 60068-2-2 test Bb	
Operating temperature	IEC 60068-2-1, test Ab, IEC 60068-2-2 test Bd	
Thermal cycle	IEC 60068-2-2, test Na, IEC 60068-2-38 (partial)	
Humidity	IEC 60068-2-78, IEC 60068-2-30 test Db	Damp heat steady state and cyclic.
Degree of protection	IEC 60529	

## Product ratings

### *Chemical environment*

Description	Applicable standard	Comment
Chemical resistance	ISO 16750-5	

### *Mechanical environment*

Description	Applicable standard	Comment
Vibration	IEC 60068-2-6 test Fc, IEC 6008-2-64 test Fh	
Bump	IEC 60068-2-29 test Eb	
Shock	IEC 60068-2-27 test Ea	
Free fall	IEC 60068-2-32 test Ed	

### *Electrical/electromagnetic*

Description	Applicable standard	Comment
EMC emission	EN ISO 14982, ISO 13766	Electromagnetic compatibility for earth moving machinery.
EMC immunity	EN ISO 14982, ISO 13766	Electromagnetic compatibility for earth moving machinery.
Electrostatic discharge	EN 60-1 000-4-2	
Auto electrical transients	ISO 7637-2, ISO 7637-3	
Short circuit protection	Danfoss test	Inputs and outputs survive continuous short circuit. Normal function resumes when short is removed.
Reversed polarity protection	Danfoss test	Survives reverse polarity at supply voltage for at least five minutes.

## Modules housing

PLUS+1® modules housing features a snap together assembly that is tamper-proof. Once assembled at the factory, the housing cannot be opened for service.

### **Caution**

Warranty will be voided if device is opened.  
 Device is not field serviceable. Do not open the device.

## Product installation and start-up

### Connectors

PLUS+1® modules use DEUTSCH connectors. Danfoss assembles mating connector kits, referred to as a bag assembly.

Mating connector bag assembly ordering information is found in module product data sheets.

#### DEUTSCH mating connector part information

Description	24 pin module	50 pin module
Crimp tool	HDT48-00 (solid contacts) (20 to 24 AWG)	HDT48-00 (solid contacts) (20 to 24 AWG)
	DTT20-00 (stamped contacts) (16 to 20 AWG)	DTT20-00 (stamped contacts) (16 to 20 AWG)
Contacts	Solid: 0462-201-2031 (20 to 24 AWG)	Solid: 0462-201-2031 (20 to 24 AWG)
	Stamped: 1062-20-0144 (16 to 20 AWG)	Stamped: 1062-20-0144 (16 to 20 AWG)
Connector plug	Gray A-Key DTM 06-12SA Black B-Key DTM 06-12SB	DRC26-50S01
Wedge	WM-12S	Not required
Strip length	3.96 to 5.54 mm [0.156 to 0.218 in]	3.96 to 5.54 mm [0.156 to 0.218 in]
Rear seal maximum insulation OD	3.05 mm [0.120 in]	2.41 mm [0.095 in]
Sealing plugs	0413-204-2005	0413-204-2005

#### Danfoss mating connector bag assembly part information

Description	24 pin module	50 pin module
Mating connector bag assembly (20 to 24 AWG)	10100945	10100946
Mating connector bag assembly (16 to 20 AWG)	10102023	10102024

#### Danfoss crimp extraction tool part information

Description	Part number
Crimp tool for 20 to 24 AWG	10100745
Crimp tool for 16 to 20 AWG	10102028
Extraction tool DEUTSCH 114010; 12 AWG	11068808
Extraction tool DEUTSCH 0411-240-2005; 16 to 20, 20 to 24 AWG	10100744

### Mounting

PLUS+1® SC modules can be mounted in one of three ways:

- End (bulkhead) installation
- Up to 3 units stacked on one another
- Individually side mounted

Care must be taken to insure that the module connector is positioned so that moisture drains away from the connector.

If the module is side or stack mounted, provide a drip loop in the harness. If the module is mounted vertically, the connector should be on the bottom of the module.

Provide strain relief for mating connector wires.

## Product installation and start-up

### **Caution**

Module damage may occur.

Use caution when installing modules. Due to the size of the mating connector wire bundle, it is possible to twist off the end cap of the module if excessive pressure is applied during the installation of harness strain relief.

#### *Fasteners*

Recommended outer diameter (OD)	Recommended torque
6.0 mm (0.25 in)	2.26 N·m (20 in·lbs)

## Machine diagnostic connector

It is recommended that a diagnostic connector be installed on machines that are controlled by PLUS+1® modules. The connector should be located in the operator's cabin or in the area where machine operations are controlled and should be easily accessible.

Communication (software uploads and downloads and service and diagnostic tool interaction) between PLUS+1® modules and personal computers is accomplished over the vehicle CAN network. The diagnostic connector should tee into the vehicle CAN bus and have the following elements:

- CAN +
- CAN -
- CAN shield

## Grounding

Proper operation of any electronic control system requires that all control modules including displays, microcontrollers and expansion modules be connected to a common ground. A dedicated ground wire of appropriate size connected to the machine battery is recommended.

## Hot plugging

Machine power should be off when connecting PLUS+1® modules to mating connectors.

## PLUS+1® USB/CAN Gateway

Communication (software uploads and downloads and service and diagnostic tool interaction) between PLUS+1® modules and a personal computer (PC) is accomplished using the vehicle's PLUS+1® CAN network.

The PLUS+1® CG150-2 USB/CAN gateway provides the communication interface between a PC USB port and the vehicle CAN bus. When connected to a PC, the gateway acts as a USB slave. In this configuration, all required electrical power is supplied by the upstream PC host. No other power source is required.

Refer to the *PLUS+1® GUIDE Software User Manual*, **AQ00000026**, for gateway set-up information. Refer to the *CG150-2 USB/CAN Gateway Data Sheet*, **A100000190**, for electrical specifications and connector pin details.

## Product installation and start-up

### Machine wiring guidelines

#### **Warning**

Unintended movement of the machine or mechanism may cause injury to the technician or bystanders. Improperly protected power input lines against over current conditions may cause damage to the hardware. Properly protect all power input lines against over-current conditions. To protect against unintended movement, secure the machine.

---

#### **Caution**

Unused pins on mating connectors may cause intermittent product performance or premature failure. Plug all pins on mating connectors.

---

- Protect wires from mechanical abuse, run wires in flexible metal or plastic conduits.
- Use 85° C (185° F) wire with abrasion resistant insulation and 105° C (221° F) wire should be considered near hot surfaces.
- Use a wire size that is appropriate for the module connector.
- Separate high current wires such as solenoids, lights, alternators or fuel pumps from sensor and other noise-sensitive input wires.
- Run wires along the inside of, or close to, metal machine surfaces where possible, this simulates a shield which will minimize the effects of EMI/RFI radiation.
- Do not run wires near sharp metal corners, consider running wires through a grommet when rounding a corner.
- Do not run wires near hot machine members.
- Provide strain relief for all wires.
- Avoid running wires near moving or vibrating components.
- Avoid long, unsupported wire spans.
- Ground electronic modules to a dedicated conductor of sufficient size that is connected to the battery (-).
- Power the sensors and valve drive circuits by their dedicated wired power sources and ground returns.
- Twist sensor lines about one turn every 10 cm (4 in).
- Use wire harness anchors that will allow wires to float with respect to the machine rather than rigid anchors.

### Machine welding guidelines

#### **Warning**

High voltage from power and signal cables may cause fire or electrical shock, and cause an explosion if flammable gasses or chemicals are present. Disconnect all power and signal cables connected to the electronic component before performing any electrical welding on a machine.

---

The following is recommended when welding on a machine equipped with electronic components:

- Turn the engine off.
- Remove electronic components from the machine before any arc welding.
- Disconnect the negative battery cable from the battery.
- Do not use electrical components to ground the welder.
- Clamp the ground cable for the welder to the component that will be welded as close as possible to the weld.

**Products we offer:**

- DCV directional control valves
- Electric converters
- Electric machines
- Electric motors
- Gear motors
- Gear pumps
- Hydrostatic motors
- Hydrostatic pumps
- Orbital motors
- PLUS+1® controllers
- PLUS+1® displays
- PLUS+1® joysticks and pedals
- PLUS+1® operator interfaces
- PLUS+1® sensors
- PLUS+1® software
- PLUS+1® software services, support and training
- Position controls and sensors
- PVG proportional valves
- Steering components and systems
- Telematics

**Danfoss Power Solutions** is a global manufacturer and supplier of high-quality hydraulic and electric components. We specialize in providing state-of-the-art technology and solutions that excel in the harsh operating conditions of the mobile off-highway market as well as the marine sector. Building on our extensive applications expertise, we work closely with you to ensure exceptional performance for a broad range of applications. We help you and other customers around the world speed up system development, reduce costs and bring vehicles and vessels to market faster.

Danfoss Power Solutions – your strongest partner in mobile hydraulics and mobile electrification.

**Go to [www.danfoss.com](http://www.danfoss.com) for further product information.**

We offer you expert worldwide support for ensuring the best possible solutions for outstanding performance. And with an extensive network of Global Service Partners, we also provide you with comprehensive global service for all of our components.

**Hydro-Gear**

[www.hydro-gear.com](http://www.hydro-gear.com)

**Daikin-Sauer-Danfoss**

[www.daikin-sauer-danfoss.com](http://www.daikin-sauer-danfoss.com)

Local address:

**Danfoss  
Power Solutions (US) Company**  
2800 East 13th Street  
Ames, IA 50010, USA  
Phone: +1 515 239 6000

**Danfoss  
Power Solutions GmbH & Co. OHG**  
Krokamp 35  
D-24539 Neumünster, Germany  
Phone: +49 4321 871 0

**Danfoss  
Power Solutions ApS**  
Nordborgvej 81  
DK-6430 Nordborg, Denmark  
Phone: +45 7488 2222

**Danfoss  
Power Solutions Trading  
(Shanghai) Co., Ltd.**  
Building #22, No. 1000 Jin Hai Rd  
Jin Qiao, Pudong New District  
Shanghai, China 201206  
Phone: +86 21 2080 6201

Danfoss can accept no responsibility for possible errors in catalogues, brochures and other printed material. Danfoss reserves the right to alter its products without notice. This also applies to products already on order provided that such alterations can be made without subsequent changes being necessary in specifications already agreed. All trademarks in this material are property of the respective companies. Danfoss and the Danfoss logotype are trademarks of Danfoss A/S. All rights reserved.