

User Guide

Plate Type Heat Exchangers, Single plate & Semi-welded  
Installation, Commissioning and Maintenance



<b>Contents</b>	<b>Introduction</b> .....	3
	<b>Safety alert notices</b> .....	3
	<b>General</b> .....	4
	<b>Design: Single plate and Semi-welded</b> .....	6
	Frame .....	6
	Single Plates .....	6
	Semi-welded plates (plate cassettes) .....	6
	Gaskets .....	6
	<b>Description</b> .....	7
	Right (R)/ Left (L) plates .....	7
	Right and left plates, Single plates .....	7
	<b>Storage</b> .....	8
	<b>Installation</b> .....	8
	Transport and lifting .....	9
	<b>Piping system</b> .....	10
	Filtration .....	10
	Installing the pipe connections .....	10
	<b>Commissioning</b> .....	11
	Start-up process .....	11
	<b>Shut-down</b> .....	12
	Shut-down for a short period .....	12
	Shut-down for a long period .....	12
	<b>Maintenance</b> .....	12
	CIP cleaning .....	12
	Cleaning agents guidance .....	12
	Opening the plate heat exchanger .....	13
	Mechanical/Manual Cleaning .....	14
	Plate/Cassette replacement .....	15
	Gasket replacement .....	15
	Closing the plate heat exchanger .....	16
	Regular Service of the plate heat exchanger .....	17
	Additional service for semi-welded heat exchanger .....	17
	<b>Troubleshooting</b> .....	18
	<b>After sales service</b> .....	19
	Ordering parts .....	19
	Modifications to the heat exchanger .....	19

## Introduction

This user guide is a guide for installation, commissioning and maintenance of plate type heat exchangers supplied by Danfoss. It is meant for those who are responsible for the installation, the use and maintenance of the heat exchangers. We recommend that you read this user guide carefully before commencing any work.

This user guide is applicable for all plate type heat exchangers produced and supplied by Danfoss.

Danfoss can not be held responsible or liable for damage as a result of incorrect installation, use and/or maintenance of Danfoss plate type heat exchanger or damage caused by as not complying with the instructions in this user guide.

Please note that our plate type heat exchangers are specially designed and built for the maximum design conditions (pressures, temperatures, capacities and type of fluids) provided by the customer and stated on the nameplate.

Sudden pressure peaks beyond the maximum operating pressure (or pressure surges) which can occur during start-up or stopping of the system can severely damage the heat exchanger and should be prevented. Danfoss can not be held responsible for any damage as a result of any operation deviating from the original design conditions.

---

## Safety alert notices

The following must always be observed when installing or servicing plate heat exchangers:

- Comply with national/local safety regulations
- Ensure that the heat exchanger is unpressurized
- Ensure that the heat exchanger is cooled down to a temperature below 40 °C (104 °F)

Warning symbols refer to safety alert notices. Warning/safety notices should be observed carefully to prevent:

Personal injury caused by:



- Wrong transport/lifting
- Burning/freezing as a result of touching parts with extreme temperatures.
- Burning/freezing/poisoning as a result of uncontrolled release of pressurized media
- Contact with chemicals
- Touching sharp edges of e.g plates or cassettes

Equipment damage caused by:



- Wrong transport/lifting
- Liquid hammering
- External forces
- Corrosion
- Chemical action
- Erosion
- Material fatigue
- Thermal and/or mechanical shock
- Freezing
- Blocking of the heat exchanger due to particles

General

*Identification of the heat exchanger*  
 All plate type heat exchangers supplied by Danfoss are provided with a name plate positioned on the front (head) of the heat exchanger.

On this plate main technical details of the heat exchanger are specified.  
 Before installation please make sure that the intended application is compliant with the name plate application data and use limitations.

Single plate heat exchanger Nameplate

Month/year of production → 12-2018 MM-YY

Type designation → S19

Serial number → IRF76804

Assembly (A) measure min. → 159 mm

Assembly (A) measure max. → - mm

Max. pressure drop → 16 Bar

Min./max. working temp. → 0 °C / 80 °C

Inlet - outlet connections → Inlet > outlet

Max. working pressure → 16 Bar

Max. allowed test pressure → 20,8 Bar

Total internal volume → 23,5 Ltr.

Fluids per side → Fluid

Ref. Side	/	Brine side	
F4 - F1	/	F3 - F2	
16	/	16	Bar
20,8	/	20,8	Bar
23,5	/	23,5	Ltr.
Water	/	Water	

Do not exceed above values at any time.  
 Please read instruction manual before installation, operation and maintenance.

Manufactured by Danfoss A/S, 6430 Nordborg, Denmark

---

Semi-welded plate heat exchanger Nameplate

Month/year of production → 02-2019 MM-YY

Type designation → SW19A-IG

Serial number → 76803

Assembly (A) measure nominal Tolerance -1.5% → 159 mm

Max. pressure drop → 16 Bar

Min./max. working temp. → 0 °C / 80 °C

Inlet - outlet connections → Inlet > outlet

Max. working pressure → 16 Bar

Max. allowed test pressure → 20,8 Bar

Total internal volume → 23,5 Ltr.

Fluids per side → Fluid

Ref. Side	/	Brine side	
F4 - F1	/	F3 - F2	
16	/	16	Bar
20,8	/	20,8	Bar
23,5	/	23,5	Ltr.
NH <sub>3</sub>	/	PropGlycol	

A-measure min.:  
 A-measure Nominal - 1.5%  
 Do not exceed above values at any time.  
 Please read instruction manual before installation, operation and maintenance.

Manufactured by Danfoss A/S, 6430 Nordborg, Denmark

Fig. 1. Nameplate examples. (\*) Danfoss Quality approval confirms PHE has passed leak test procedure

**General**  
(continued)

Each heat exchanger comes with a data list specifying key components and relevant

accessories as per specific customer order, heat exchanger dimensions, and an assembly drawing.

**Datalist (example)**

Customer:		Contact person:	
Project:		E-mail:	
HEX Type:		Engineer:	
Unit:	Code:	Date:	
1 (Parallel)	SW40A-72-TM		IR
		04-03-2019 16:28:08	

Calculated parameters	Unit	Ref Side	Co-Current	Brine Side
Flow Type			Co-Current	
Load	kW		350,00	
Inlet temperature	°C	-7,59		-1,00
Evaporating temperature	°C	-8,00		
SuperHeating	K	0,00		
Outlet temperature	°C	-8,00		-5,00
Inlet/Outlet quality		0,000/0,667		
Mass flow rate	kg/h	1464,4		83899,1
Volumetric flow rate	L/min			1346,458
Total pressure drop	kPa	5,03		93,71
Pressure drop - In port.	kPa	0,63		5,20
Total area	m²		26,60	
Surface margin	%		8,7	
LMTD	K		4,48	
HTC(Available / Required)	W/m²-K		3189/2935	
Heat flux	kW/m²		13,158	
Abs.Evaporating pressure	bar	3,15		
Port velocity	m/s	0,09(Inlet)/15,22(Outlet)		3,23
Shear stress	Pa	5,41		109,07

Properties of fluid	Unit	Ref Side	Brine Side
Fluid		Ammonia	Ethylene glycol(25,00%)
Liquid viscosity	mPa-s	0,1855	3,6207
Liquid density	kg/m³	649,1	1039,1
Liquid heat capacity	kJ/kg-K	4,575	3,755
Liquid thermal conductivity	W/m-K	0,583	0,451
Vapor viscosity	mPa-s	0,0088	
Vapor density	kg/m³	2,6	
Vapor heat capacity	kJ/kg-K	2,570	
Vapor thermal conductivity	W/m-K	0,023	

Specification:	Unit	Ref Side	Brine Side
HEX Type:	-	SW40A-72-TM	
Number of plates:	-	72	
Max.number of plates in current frame:	-	84	
Grouping:	-	(35TM)/(36TM)	
Plate thickness / material:	-	0,5mm / EN1.4301(AISI304)	
Main Gasket / Ring Gasket:	-	NITRIL HT (H) / CHLOROPRENE	
Connection:	-	DN 100 Flange cl. AISI316 PN16	DN 100 Flange cl. AISI316 PN16
Counter Flange	-	Yes	Yes
Frame type / color:	-	C2L / RAL3020	
Certification/Approval type:	-	PED	
Volume:	L	26,28	28,7
Weight:	kg	253,74	
Min. wall temperature	°C	-7	-6,56
Design Temp. (Max/Min):	°C	50/-12	
Design Pressure(Max) Ref/Brine:	bar	16/16	

**Drawing (example)**

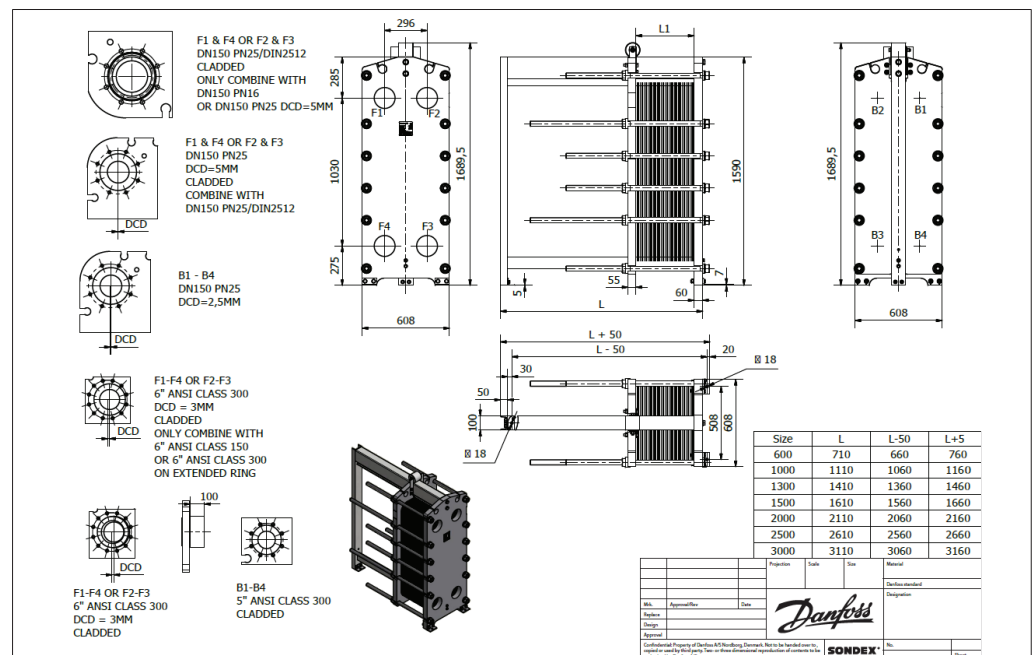

Fig. 2. Standard documentation datalist and drawing (examples)

**Design:  
Single plate and  
Semi-welded**

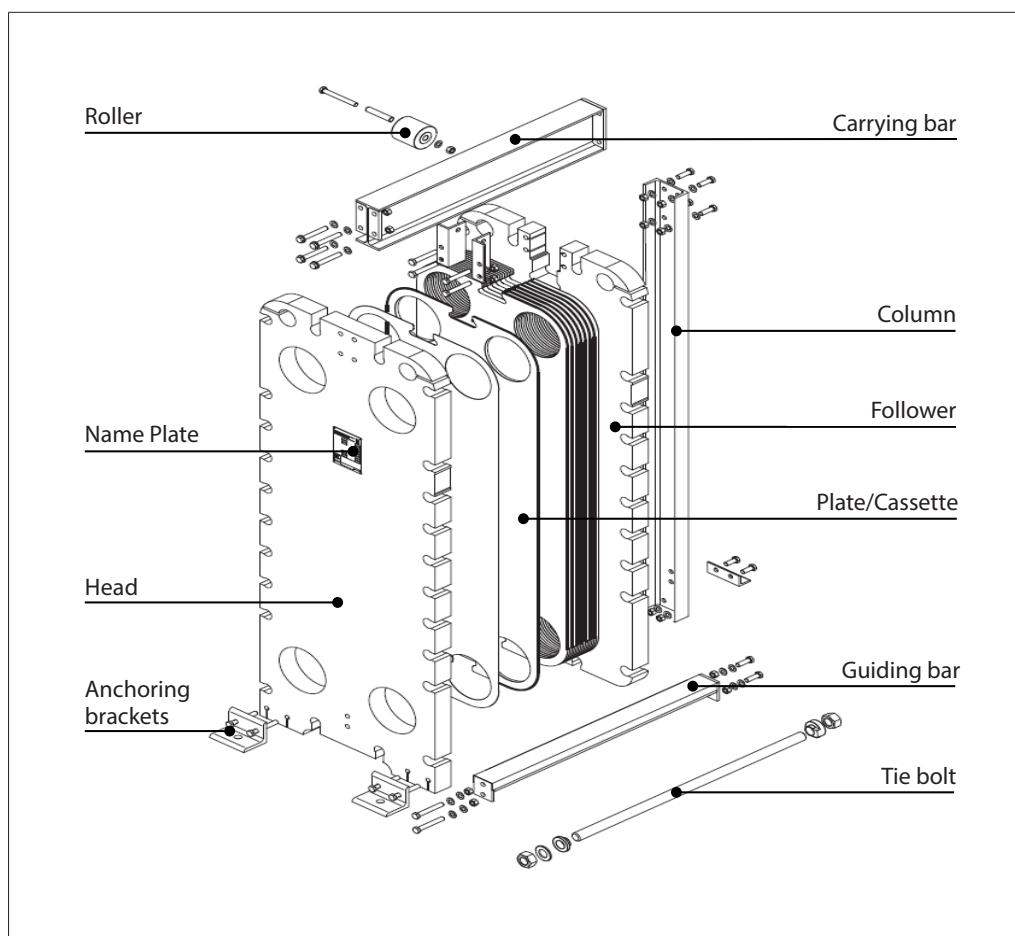

Fig. 3. Construction of generic Semi-welded heat exchanger.  
Single Plate construction is identical except plates are not paired (welded) into cassettes.

**Frame**

The heat exchanger consists of a frame plate (head), a pressure plate (follower), a carrying bar, a guiding bar and a column. Tie bolts are used to press the plate package together. The size and number of bolts depend on the type of heat exchanger.

**Single Plates**

Single plate pack consists of single plates fitted with a flow gasket on each plate to seal the plate pack. The number of plates, size and dimension depend on the thermal output required. The number of plates determines the total heat transfer area (surface).

**Semi-welded plates (plate cassettes)**

A plate cassette consists of two single flow plates welded together, creating a sealed flow channel. The cassettes are fitted with two individual gaskets, a ring gasket and a field gasket, to seal the plate pack preventing the intermixing of media. This gasket design allows the use of different gasket materials for the ring and field gaskets respectively for best fit to the actual media and temperature conditions.

The ring gasket material is carefully selected to match the combination of temperature and chemical resistance requirements (e.g. NH<sub>3</sub> and compressor oil on the welded side).

**Gaskets**

The following gasket types are used in Danfoss plate type heat exchangers:

- Sonderlock gaskets
- Glued gaskets
- Sonder Snap gaskets (semi-welded plate heat exchangers, large range)
- Hang-on gaskets (semi-welded plate heat exchangers)



Fig. 4. "Hang-on" gasket

**Description**  
(Continued)

*Right (R)/ Left (L) plates*

Plates are designed in such a way that they can be used both as right and left plates by alternately turning them 180°. Semi-welded cassettes are not turned.

On a left plate the flow runs from porthole 1 to 4 or reverse from porthole 4 to 1.

The opening of the corner portholes is described in a "plate code index". For instance 1234 means that all corner portholes are open. Every plate can be identified by the gasket configuration, the plate code index, and the plate geometry (e.g. thermal short or thermal long geometry).

*Right and left plates, Single plates:*

On a right plate the flow runs from porthole 2 to 3 or reverse from porthole 3 to 2.

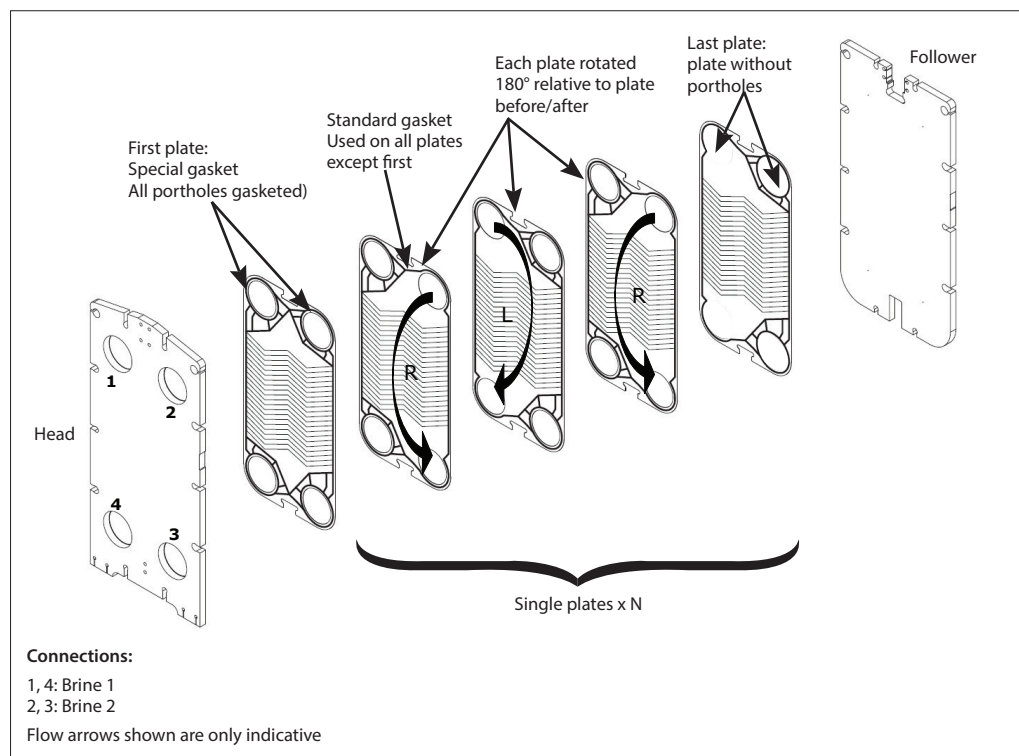

Fig. 5. Single plates: Left and Right plates and flow

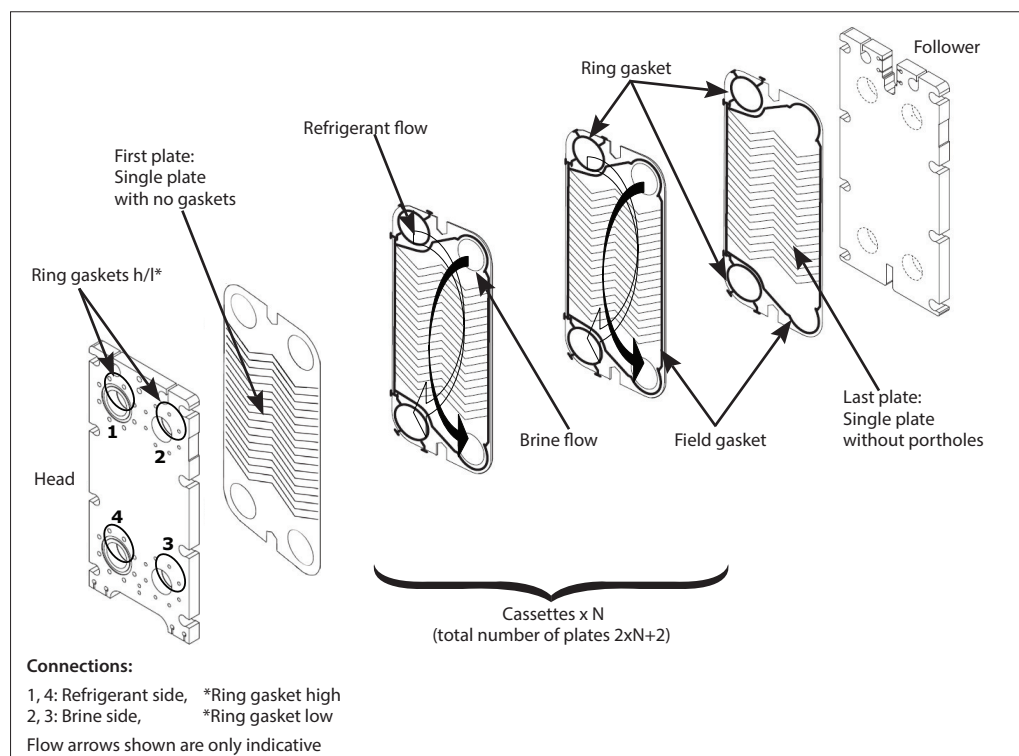

Fig. 6. Semi-welded plates (cassettes) have no Left and Right plates. Refrigerant always flows in port 1 and 4

**Storage**

If storing the plate heat exchanger for a longer period of time, i.e. more than one month/30 days, the following precautions should be taken to prevent unnecessary equipment damage:

Preferably the plate heat exchanger should be stored inside in dry conditions at room temperatures around 15 – 20 °C (59 – 68 °F) and a humidity of maximum 70%.

If this is not possible, place the plate heat exchanger in a wooden box provided with a lining on the inside that will prevent against moisture penetration.

Rubber gasket material is sensitive to certain agents and ultraviolet radiation.



- Plate heat exchangers must be stored in rooms with no ozone producing equipment such as electric motors or arc-welding equipment as ozone may destroy several rubber materials
- Plate heat exchangers should not be stored together with any organic solvents or acids in the room
- Do not expose the plate heat exchanger to ultraviolet radiation

**Installation**

*Foundation*

Install the heat exchanger on a flat foundation providing sufficient support for the frame.

*Space*

Ensure enough space around the plate heat exchanger for servicing the unit (renewal of plates, tightening of the plate pack). As a rule, free space around the unit should be 1.5 to 2 x the width of the unit. See Fig. 7.

*Drip tray*

Replaceable plate heat exchangers involve a risk of leakage. It is recommended to take this into account while installing. Preferably install a drip tray underneath the heat exchanger to prevent leakages onto the floor and/or harm to electrical equipment.

*Screen plate*

If the heat exchanger is being used with temperatures above 60 °C or with aggressive fluids, we advise that you cover the heat exchanger with a screen plate to prevent the risk of human exposure to the surface and fluids.

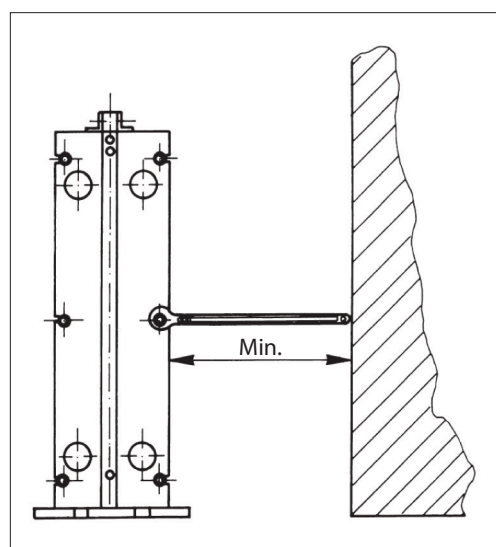

Fig. 7. Ensure enough free space for servicing the plate heat exchanger



**Installation**  
(Continued)

*Transport and lifting*

**WARNING:**  
To prevent personal injury always use appropriate hoisting equipment. If you are to lift the heat exchanger itself, straps should be used. The straps should be placed as shown in fig. 8.

Usually the heat exchanger will be supplied horizontally on a pallet.

The back side of the head will then be secured to the pallet. This allows the unit to be transported by means of a forklift truck.

Raising of the unit: see fig. 8.

- Remove all tightening elements from the pallet
- Place straps around opposite bolts on each side of the column (1)
- Lift the unit vertically from the pallet (2)
- Remove the pallet securely (3)
- Slowly lower the heat exchanger to the floor (4)
- Remove the straps at the unit bottom side (5)
- Lift one-sided in an appropriate lifting angle (6) and follow the raising of the unit carefully. Avoid any bumps or shocks
- Once the heat exchanger is in upright position place the straps in the dedicated lifting eyes (7) and lift the unit to its final position (8)
- Remove the straps and mount the heat exchanger securely to the floor

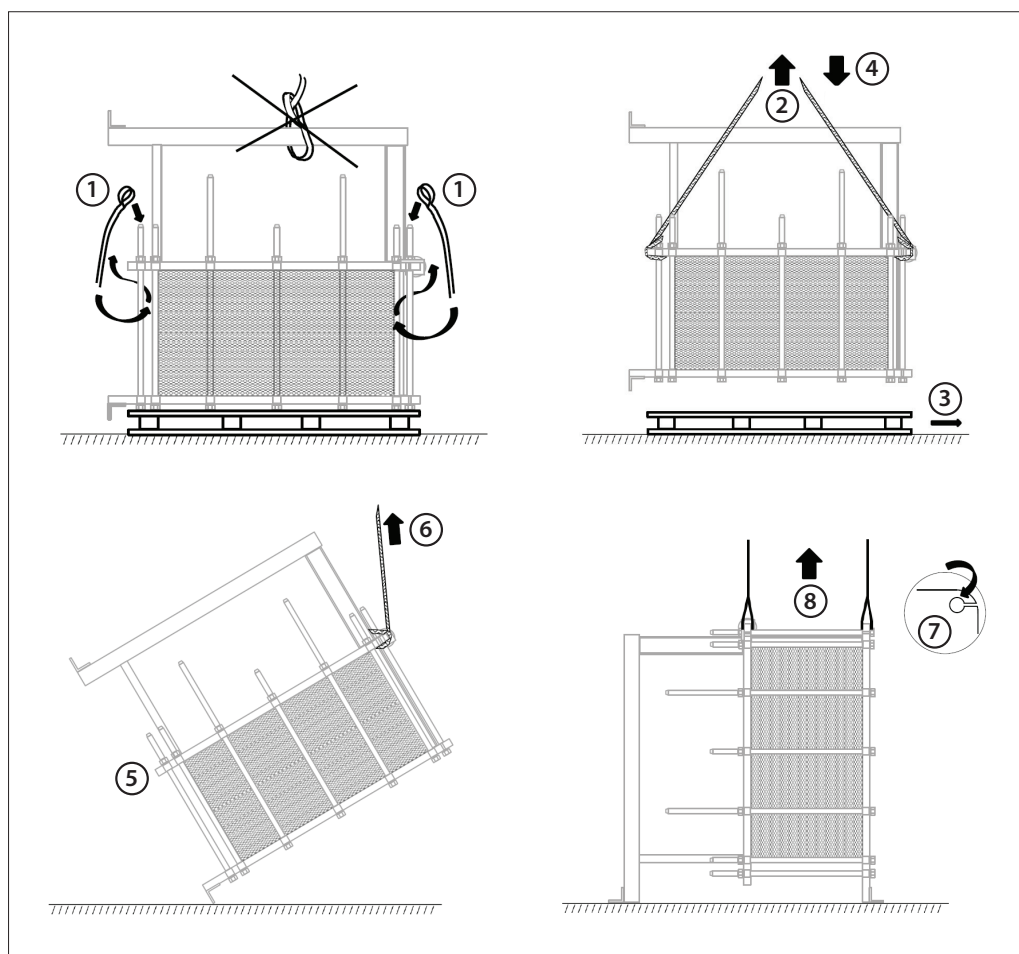

Fig. 8. Lifting instructions

**Never lift the heat exchanger using any other method than described above. Never use the connections, studs or any intermediate plates (if fitted) for lifting (fig. 9).**

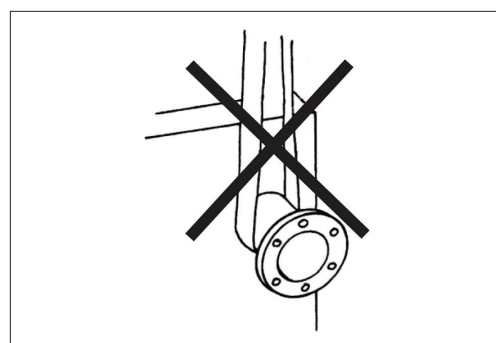

Fig. 9. Lifting points not allowed

## Piping system

### Filtration

If the fluid in the plate heat exchanger contains particles larger than Ø0.5mm an inline filter should be fitted.

### Installing the pipe connections

Most plate heat exchangers are intended for counter-current flow directions, but some specific applications require co-current flow. Refer to name-plate for information on each specific plate heat exchanger.

Danfoss plate type heat exchangers are provided with various connection types depending on size, application and conditions.

**Single plate** heat exchangers come with threaded pipe connections or studded flanges ready for counter/blind flanges.

**Semi-welded** heat exchangers come with factory installed welding flanges. The refrigerant side is hermetically closed by blind plates and pressurized with nitrogen.



**Before connecting any piping to the plate heat exchanger make sure to clean and flush the piping system thoroughly for any foreign objects.**

**When connecting the piping system to the plate heat exchanger make sure that the piping system does not subject the plate heat exchanger to stress or strain.**

**Make sure that the piping system, connected to the plate heat exchanger, is secured against pressure peaks/ surges and temperature shocks!**

**When doing any welding in the flange/ valve/piping system make earthing to the piping opposite of the plate heat exchanger. Never use the heat exchanger for earthing as plates and gaskets might be severely damaged.**

**When fitting threaded pipe to the threaded plate heat exchanger connection make sure that the connection do not rotate during tightening as this might damage internal ring gaskets. A secure counter-hold is needed.**

**For studded flange connection, insert the gaskets before bolting the blind flanges to the end plate. Tighten the bolts evenly - do not over-tighten as this might damage bolts/threads.**

### Note:

- Identify actual flow inlets/outlets on the name plate before commencing piping work
- Heavy piping should be supported. This will prevent heavy forces on the plate heat exchanger
- To be able to open/close and dismantle the plate heat exchanger shut off valves should be installed in all connections
- Remove flanges from the plate heat exchanger before connecting to the valve/piping system.
- Nitrogen pressurized refrigerant side must be depressurized through the small valve in the blind plate before removing the flanges
- Always install flexible connections on the follower to prevent vibrations on the plate heat exchanger. The flexible connections also help prevent expansion of the pipes, which could be caused by temperature influence
- Flexible connections must be fitted perpendicular to the header/follower
- Install vents on both sides of the plate heat exchanger
- The vents should be fitted on the highest point in the direction of the media flow
- The installation must be fitted with safety valves according to current pressure vessel regulations

**Commissioning**

Commissioning, control, maintenance and repair of the installation should be done by authorized, trained and properly instructed staff.



**The plate heat exchanger must not be subject to thermal or mechanical shock as this could lead to premature gasket failure.**

Before commissioning check if all connections are fitted correctly.

Check the pressures and the temperatures of the media and make sure they are within the limits of the values specified on the name plate.

*Start-up process*

*Single plate heat exchanger*

For plate heat exchangers with liquid on both sides (liquid/liquid flow) the flow with an operating temperature closest to the ambient temperature is to start first, i.e.

*Flow 1*

Delta T to ambient temperature lowest

*Flow 2*

Delta T to ambient temperature highest

**Start liquid flow 1 first, then liquid flow 2.**

For both flows follow these steps:

- Vent the system fully
- Close shut off valve fitted between pump and plate heat exchanger
- Fully open valve fitted into return line from the plate heat exchanger
- Start the circulation pump usually placed at the inlet
- Gradually open the closed shut off valve between pump and plate heat exchanger
- Vent system again if necessary

*Start-up process*

*Semi-welded heat exchanger*

For semi-welded plate heat exchangers with refrigerant on one side and glycol/water on the other side, the glycol/water side, i.e. the liquid flow, must be started first.

**Start liquid flow first, then refrigerant flow.**

For the liquid flow follow steps mentioned above.

For refrigerant flow follow these steps:

- Keep shut-off valves at the plate heat exchanger connections closed, while evacuating the heat exchanger completely
- Gradually open the shut-off valve at the outlet for pressure equalization and subsequently gradually open the inlet to the heat exchanger
- Activate the refrigerant system following normal procedure



**If a high pressure difference is present and refrigerant in liquid phase in connecting pipes, precautions should be taken to avoid liquid hammer. Liquid hammer may cause considerable damage to the equipment and cause refrigerant leakage to the ambient.**

*Check during operation*

*For proper and safe operation*

- Check the system for potential pressure pulses caused by pumps or control valves. In case of pressure pulses, stop operation and rectify
- Continuous pressure pulses could cause fatigue issues of flow plates
- Check that no leakages appear from the unit
- Check that all vents are closed to prevent air being sucked into the system
- Check that the operating conditions including media temperatures and pressures are within the limitations stated on the name plate. These must not be exceeded



**When in operation the conditions should not be changed. Media temperatures and pressures must be within the limitations stated on the name plate and should not be exceeded.**

**Shut-down**

*Shut-down for a short period*

If the plate heat exchanger has to be shut down for a short period the following procedure should be followed:

- Gradually close the inlet control valve in the refrigerant (flow 2) circuit whilst maintaining the full flow in the liquid circuit (flow 1)
- For high temperature applications cool down the heat exchanger to below 40 °C ( 104 °F)
- Gradually close the inlet control valve in the liquid (flow 1) circuit
- Switch off the liquid (flow 1) circuit pump

*Shut-down for a long period*

If the unit is to be shut down for an extended period of time then the following procedure should be followed:

- Follow steps above
- Allow unit to reach ambient temperature
- Ensure a minimum amount of refrigerant in the heat exchanger. Boil off using flow 1 in evaporators or use liquid drain in condensers.
- Evacuate refrigerant side
- Drain flow 1 circuit
- Lubricate threads on the tie bolts
- Loosen tie bolts according to the instruction in “opening the plate heat exchanger” section until the length of the plate pack reaches:
  - Single plate: A-measure max. +10%
  - Semi-welded: A-measure Nominal +10%
- The tie bolts should not be removed or loosened to such an extent that dirt is allowed to enter in-between the plates. It is recommended to attach a warning notice to the plate heat exchanger to remind personnel that the tie bolts need adjustment before the unit can be put back into service
- Cover the plate pack with black plastic to exclude any sunlight

**Maintenance**

*CIP cleaning*

Clean-in-Place, CIP cleaning, allows cleaning the plate heat exchanger without opening it and is done by circulating cleaning agents in the heat exchanger.



**CIP cleaning of the refrigerant circuit is not allowed. CIP cleaning can be done only on the brine circuit.**

The use of CIP cleaning is relevant for soluble fouling only. Prior to CIP cleaning ensure that all materials in the entire circulation system are resistant to the cleaning agent/CIP liquid used.



**We advise to ask for a confirmation from the supplier of the cleaning agent that it will not damage the materials in the heat exchanger.**

Check maximum allowable working temperature on the name-plate mounted on the head of the plate heat exchanger before performing CIP cleaning. Maximum working temperature should not be exceeded at any time. Consult Danfoss if in doubt.

If the solution requires recirculation, select a flow that is as high as possible, and no less than the service or operation flows.

Follow the instructions from the supplier of the cleaning agent. For re-circulated cleaning, we recommend that fluid is circulated in the plate heat exchanger for no less than 30 minutes.

*Rinsing*

After using any type of cleaning agent, always rinse the plate heat exchanger thoroughly with fresh water. After CIP cleaning, circulate fresh water for at least 10 minutes.

*Cleaning agents guidance*

Oil and grease can be removed with a water emulsifying oil solvent.

Organic and grease cover can be removed with sodium hydroxide (NaOH) maximum concentration 1.5% - max. temp. 85 °C (185 °F). Mixture for 1.5% concentration = 5 l 30% NaOH per 100 l water.

Stone and limestone can be removed with nitric acid (HNO<sub>3</sub>) - max. concentration 1.5% - max. temp. 65 °C. Mixture for 1.5% concentration = 2.4 l HNO<sub>3</sub> 62% per 100 l water.

Nitric acid has an build up effect on the passivation film of stainless steel.



**CAUTION:**  
**Nitric acid and Sodium Hydroxide may cause injury to exposed skin, eyes, and mucous membranes. Use of protective eyewear and gloves is strongly recommended.**

**Maintenance**  
(Continued)

*Opening the plate heat exchanger*  
When opening and disassembling the plate heat exchanger observe the following:

- Mark the plate package before opening. This can be done by a diagonal line (see fig. 10) or by numbering each individual plate in sequence
- Measure and note the actual assembly measure (Reference name plate for validation).
- Use appropriate tools and lubricant
- Shut down the heat exchanger as described in section "Shut down"
- Make sure the heat exchanger cools down (<math><40\text{ }^{\circ}\text{C}</math> (104 °F))

- The liquid side must be drained and the refrigerant side must be properly evacuated before the heat exchanger is opened
- Clean the tie bolts and grease the threads
- Loosen all the short tie bolts while leaving the long tie bolts in tension
- Loosen the long tie bolts evenly in the numbered order 1, 2, 3, 4 (fig. 10) i.e. the follower shall have a parallel opening motion

**CAUTION:**  
**Ensure unit is depressurized and drained of hot and/or aggressive fluid before unit is opened to prevent personal injury.**

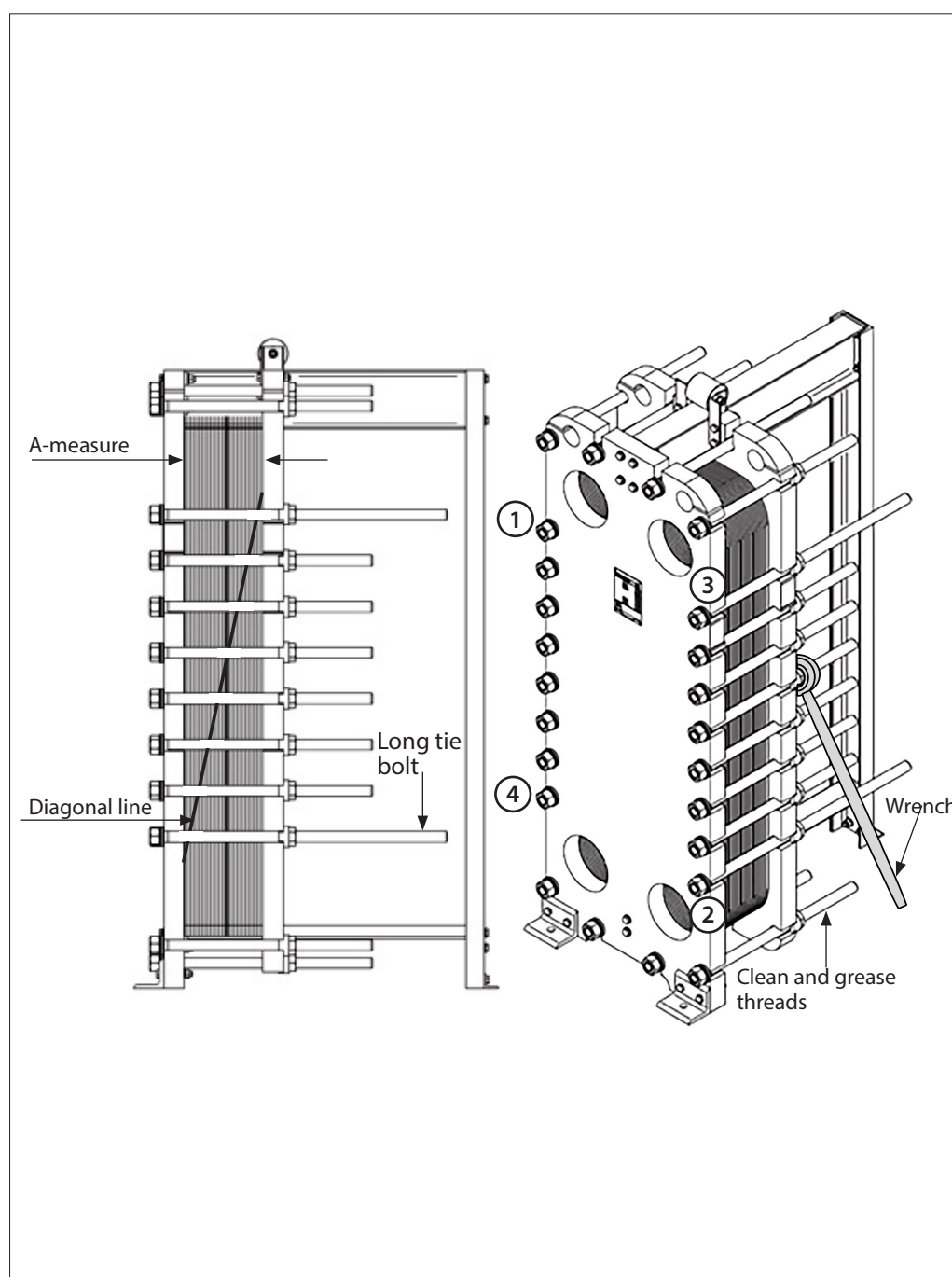

Fig. 10. Opening the plate heat exchanger

**Maintenance**  
(Continued)

*Opening the plate heat exchanger (continued)*

- Remove all tie bolts
- Pull the follower back towards the column
- Remove the plates/cassettes one by one without damaging the gaskets

**CAUTION:**  
Plates/cassettes have sharp edges!  
When handling plates/cassettes always wear gloves

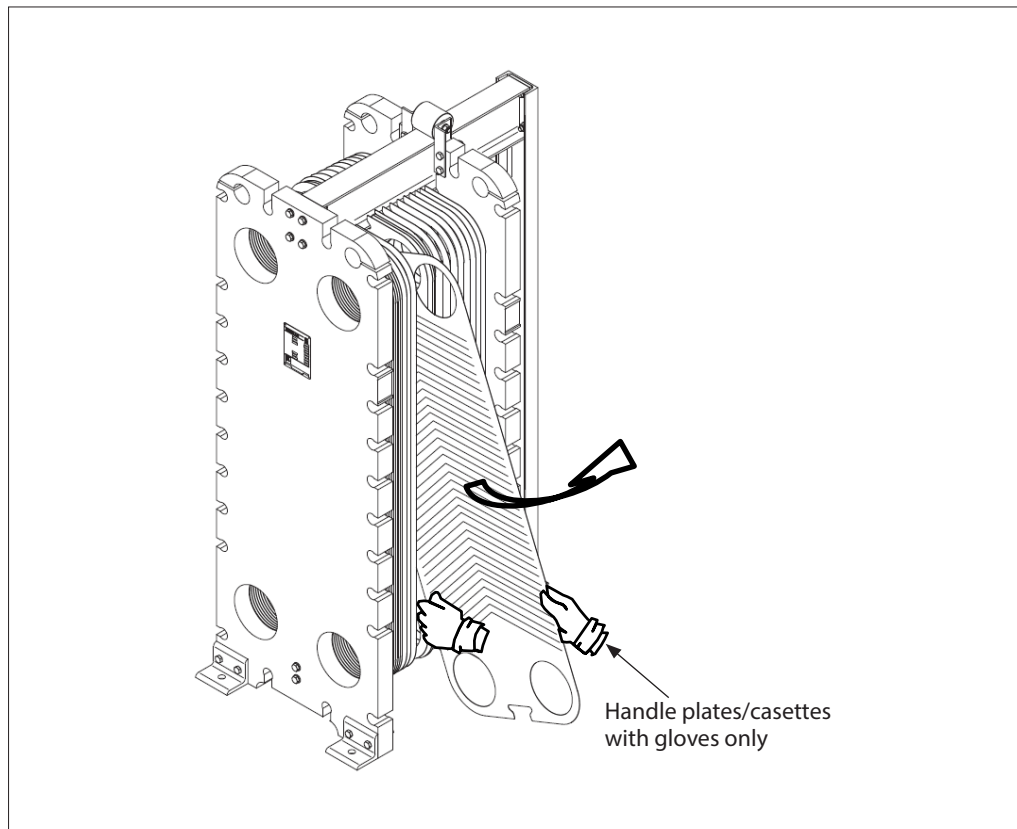

Fig. 11. Removal of plates

*Mechanical/Manual Cleaning*

- Plates/Cassettes can be mechanically cleaned by use of water and a soft brush. Alternatively a high pressure cleaner might be used with caution and without abrasives
- If needed cleaning agents may be used
- Cassettes are only cleanable on the brine side and all precautions must be taken to avoid any water or cleaning agent entering the welded cassettes
- Consult a cleaning specialist for choosing a suitable cleaning agent. Ensure that all agents used are compatible with the plate/cassette and gasket material

**CAUTION:**  
Some cleaning agents may cause injury to exposed skin, eyes and mucous membranes. Use of protective eye-wear and gloves is strongly recommended.

**Never allow any water or cleaning agent to enter the welded side of the cassettes.**

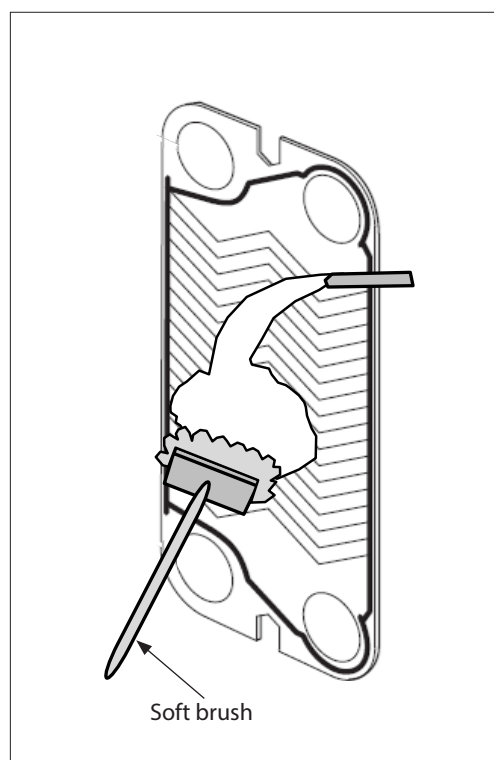

Fig. 12. Mechanical cleaning with soft brush

**Maintenance**  
(Continued)

*Mechanical Cleaning continued*



**Never use a metal brush, steel wool or sand/glass paper. This will damage the passivation film of the plates. Never use Hydrochloric for Stainless steel plates. Never use Hydrofluoric for Titanium plates.**



**Before fitting chemical cleaned plates they need to be thoroughly rinsed with fresh water!**

- Always remove plates/cassettes one by one and number them in right order
- Plates/cassettes removed for manual cleaning must be re-fitted in the same order
- Single plates may be immersed into a solvent bath to dissolve hard fouling

*Plate/Cassette replacement*



**If a plate/cassette has to be renewed because of serious damage, it is recommended to replace the plates/cassettes next to this plate/cassette.**

- Plates/Cassettes must be replaced if damaged or not cleanable
- When ordering new plates/cassettes all data from the nameplate is required
- New plates/cassettes are supplied with complete gaskets ready for immediate installation

*Gasket replacement*

**Glue free gaskets / Sonder Snap, Sonderlock & Hang-on gaskets**

These gaskets are mounted without the use of any glue. They are positioned by pushing the gasket fully down into the gasket groove or fastened by special devices. Make sure groove and gasket are clean.

*Glue type gaskets*

The surfaces need to be clean and free of oil. Only use chloride free glues like Pliobond 20 or 30, Bostic 1782, 3M EC 1099 and Bond Spray 77. Follow the instructions of the manufacturer.



**CAUTION:**  
**When using commercial solvents and adhesives, follow the manufacturers recommendations carefully. Most of these solvents are hazardous.**

*Semi-welded gaskets*

The 2 types of gaskets in Semi-welded heat exchangers - ring gaskets for refrigerant side and field gasket for liquid side - can be replaced independently (see fig. 6).

**Maintenance**  
(Continued)

*Closing the plate heat exchanger*

When assembling and closing the heat exchanger observe the following:

- Check that all gaskets are correctly positioned in the grooves
- Check that plates/cassettes are hanging correctly on the carrying bar
- Press the plate package together by pushing the follower
- Make sure the plates are in the correct position according to the marked diagonal or numbering
- Check the plate/cassette edge pattern for uniformity (see fig. 13)
- Identify the A-measure noted prior to opening the heat exchanger (confirm with nameplate)
- Use appropriate tools and lubricant
- Ensure there is no flow to any part of the unit
- Clean the tie bolts and grease the threads
- Install the long tie bolts and tighten evenly in the numbered order 1, 2, 3, 4 (fig. 14) until a resistance can be noticed. i.e. the follower shall have a parallel closing motion
- Tighten the long tie bolts in sequence 1 to 4 alternately until the A-measure has been reached at all long tie bolts
- Tighten the short tie bolts in an alternating order until the A-measure has been reached at all tie bolts

- Prepare for operation. Follow instructions in section "Start-up process"
- If the heat exchanger does not seal immediately the tie bolts can gradually be tightened to A-measure minimum (see name plate)

 **The A-measure shall never be less than A-measure minimum.**

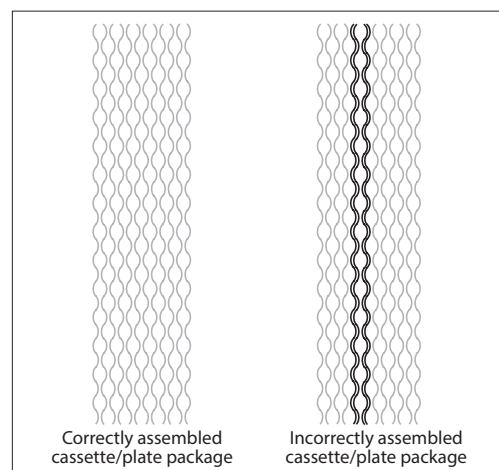

Fig. 13. Correct/Incorrect assembled plate package

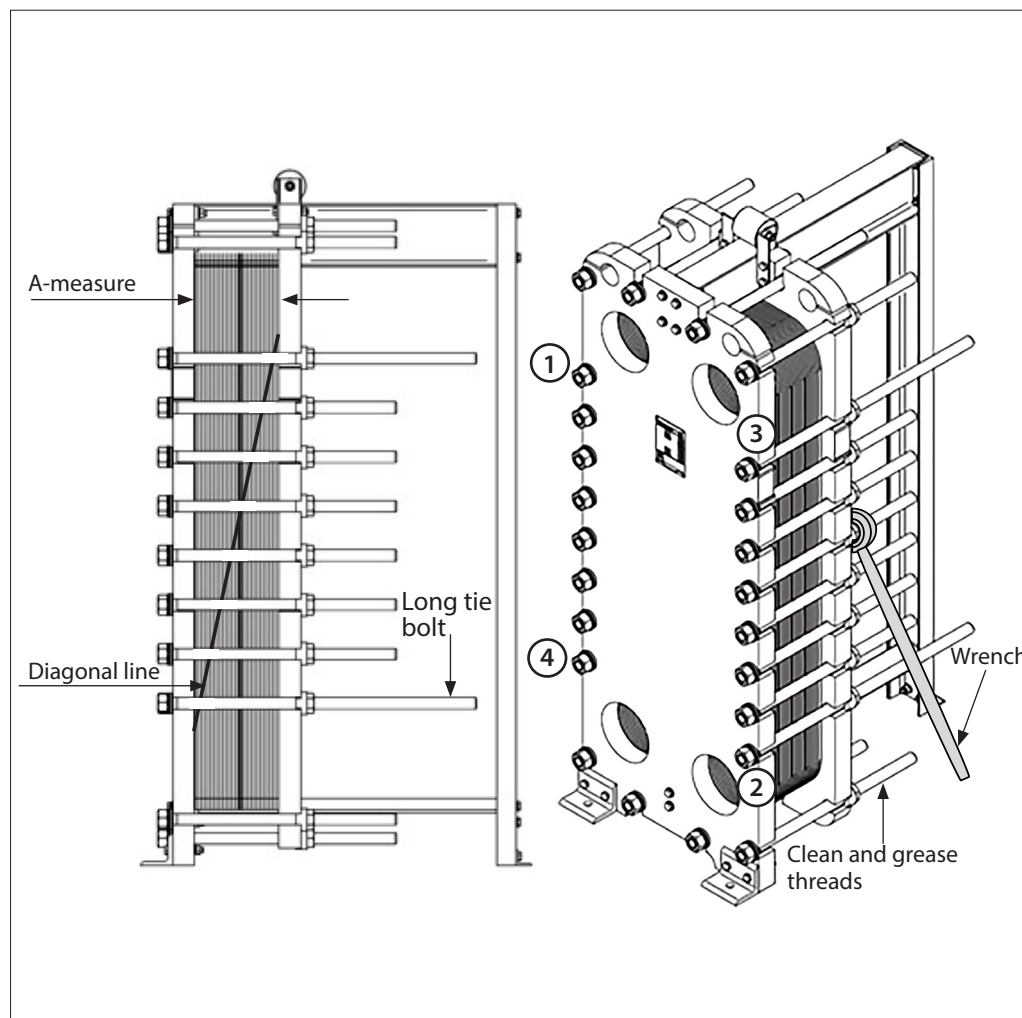

Fig. 14. Closing the plate heat exchanger. Note: The A-measure shall never be less than A-measure minimum (see name plate)



**Maintenance**  
(Continued)

*Regular Service of the plate heat exchanger*

**Service sequence – once a year as a minimum**

- Check temperatures and flows against commissioning data
- Check general condition and look for any signs of leakage
- Wipe clean all painted parts and check surfaces for signs of damage – “touch up” if necessary

- Check bolts and bars for rust and clean. Coat threaded parts with molybdenum grease or a corrosion inhibitor (ensure that no grease, etc. falls onto the plate gaskets)
- If rollers are fitted to the follower, lubricate the bearings with light machine oil

*Additional service for semi-welded heat exchanger:*

		Clean fluids/normal conditions				Dirty fluids/severe conditions			
<b>Years after commissioning</b>	<b>2</b>					PHE audit	Leak detection refrigerant	CIP and manual cleaning	Replace ring gaskets*
	<b>3</b>	PHE audit	Leak detection refrigerant	CIP cleaning					
	<b>5</b>	PHE audit	Replace ring- and main body gaskets**	Leak detection refrigerant	CIP and manual cleaning	PHE audit	Replace ring- and main body gaskets**	Leak detection refrigerant	CIP and manual cleaning
	<b>6</b>								
	<b>7</b>	PHE audit	Leak detection refrigerant	CIP cleaning		PHE audit	Leak detection refrigerant	CIP & manual cleaning	Replace ring gaskets*
	<b>8</b>								
	<b>10</b>	Replace ring- and main body gaskets**	Leak detection refrigerant	CIP and manual cleaning		PHE audit	Replace ring- and main body gaskets**	Leak detection refrigerant	CIP & manual cleaning
	<b>12</b>								
	<b>13</b>	PHE audit	Leak detection refrigerant	CIP cleaning		PHE audit	Leak detection refrigerant	CIP & manual cleaning	Replace ring gaskets*
	<b>15</b>								

*Fig. 15. Guideline for service intervals for semi-welded plate heat exchangers. Indicative for clean fluids/normal conditions and dirty fluids/severe temperature-pressure conditions respectively*

\* Ring gasket kit

\*\* Full gasket kit

PHE audit: Visual inspection of operating conditions, leaks, corrosion and general condition

Leak detection refrigerant: Electronic testing (sniffer)

CIP: Clean in place (See section "clean in place")

Manual cleaning: Plate pack disassembly/plate cleaning

Replace gaskets: Plate pack disassembly/replace gaskets

At extreme fluids/conditions audits should be performed more frequent

**Troubleshooting**

Most common problems with a plate heat exchanger, can be solved by own trained personnel. Fig.16 lists a summary of possible problems together with relevant possible causes and solutions.

Exceeding these values, even as short-lasting peaks, may damage the unit or could be the cause of problems/issues. To avoid costly repairs, it is recommended to have the installation and maintenance carried out by properly trained personnel.

To maintain a continuous proper function of the plate heat exchanger ,it is essential to keep the operating pressure and temperature within the ranges stated on the nameplate.

Problem	Possible cause	Possible solution
<b>Leakage</b>	Connection sealing damaged	Check the rubber liners (if fitted)
		Check the flange gasket (if fitted)
		Check the ring gasket at first plate
		Fit the pipes tension-free
	Mixing of primary and secondary circuit	Check the plates for holes and/or cracks
		Single plate: Check the gaskets around the port and diagonal areas Semi-welded: Check the diagonal part of the field gasket and ring gasket
	Plate package sealing damaged	Check the assembly distance "A"
Check the condition of the gaskets		
Check the proper position of the gaskets		
	The operating conditions deviate from the specification	Adjust the operating conditions
<b>Insufficient capacity</b>	Air in the system	Vent the piping system Check the pipe work for possible air traps
	The operating conditions deviate from the specification	Adjust the operating conditions
	The heat exchanger is fouled internally	Clean the heat exchanger
	The connections have been interchanged	Redo the pipe work
<b>Too high pressure drop</b>	Flow larger than the design flow	Adjust the flow
	Channels in plates blocked	Flush / clean
	Incorrect measurement	Check the pressure indicator
	Fluid deviating from the specification	Check the chemical composition
	Air in the system	Vent the piping system Check the pipe work for possible air traps

Fig. 16. Summary of possible problems, causes and solutions

For nearly all leakage problems it will be necessary to dismantle the unit before any attempts to rectify the fault can be made. Mark the area(s) where the leakage seems located with a felt tip marker or similar before disassembling the plate heat exchanger. Follow the instructions in section "Opening the plate heat exchanger".

“Cold leakage” is caused by a sudden change in temperature. The sealing properties of certain elastomers are temporarily reduced when the temperature changes suddenly. No action is required as the gaskets most often re-seal after the temperature has stabilized.

**Troubleshooting**  
(Continued)

*Gasket failures are generally a result of*

- Material aging/degradation
- Excessive exposure to ozone
- High or low operating temperature - outside specified material limits
- Exposure to pressure surges
- Attack by chemicals from cleaning, refrigerants or oils
- Physical damage from incorrect assembly work
- Misaligned plates (check the hanging system at the top of the plate for distortion)

*Decrease in performance is generally a result of*

- Plate surfaces require cleaning or de-scaling
- Pumps or associated controls failing
- Plate channels blocked

- Liquid flows not as specified
- Associated chiller / cooling tower / boiler under sized or dirty
- Cooling fluid temperature to the plate heat exchanger is higher than the design temperature
- Heating fluid temperature to the plate heat exchanger is lower than the design temperature
- Refrigerant trap broken or jammed – unit becomes filled with condensate
- Plate package has been assembled incorrectly
- Plate heat exchanger is running with co-current flow, instead of counter-current. (Check direction of pump flows)
- Air trap has developed in the plate package or piping work

---

**After sales service**

*Ordering parts*

When ordering spare parts it is important to provide correct data for:

- Project and order number
- Plate heat exchanger type and manufacturing number (see name plate)
- Required parts

When ordering separate plates it is important that the correct plate code index and type of plate is given.

When ordering separate gaskets it is important to indicate the correct gasket material.

When ordering tie bolts, the existing bolts should be measured in order to get spare bolts with the same dimensions.

*Modifications to the heat exchanger*

Please note that a plate heat exchanger is specific designed and built for the operating parameters (pressures, temperatures, capacity and type of fluids) initial provided by the customer.

If the plate heat exchanger needs to operate at a different capacity this can be achieved by adding or removing plates/cassettes.

Modification of the plate heat exchanger to match other parameters may also be considered. Consult Danfoss for redesign and/or approval of any change to operating parameters. After approval by Danfoss a new name plate will be issued.

You may only commission a plate heat exchanger under modified conditions after written approval by Danfoss.

ENGINEERING  
TOMORROW



---

Danfoss can accept no responsibility for possible errors in catalogues, brochures and other printed material. Danfoss reserves the right to alter its products without notice. This also applies to products already on order provided that such alterations can be made without subsequential changes being necessary in specifications already agreed. All trademarks in this material are property of the respective companies. Danfoss and the Danfoss logotype are trademarks of Danfoss A/S. All rights reserved.

---