

Safety guide

# Pressure transmitter SIL-2 DST P92S



Table of contents	Contents	
1.	Introduction .....	2
2.	General information.....	3
2.1	Contact.....	3
2.2	Used symbols and format.....	3
2.3	Reference.....	3
2.4	Abbreviations.....	4
3.	Qualification test.....	5
3.1	Compliance information.....	5
3.2	Electromagnetic and electrical tests.....	5
3.3	Environmental qualification.....	12
4.	System information.....	13
4.1	Functional safety classification.....	13
4.2	Technical data.....	14
4.3	Technical drawings.....	16
4.4	Pin configurations.....	17
4.5	Wiring diagram.....	17
4.6	Safety functions.....	17
4.7	Diagnosis.....	18
5.	Safety requirements.....	18
5.1	Known issues.....	19
5.2	Instructions and constraints.....	19
5.3	Safe state.....	19
5.4	System.....	20
5.5	Pressure.....	21
5.6	Outputs.....	22
5.7	Decommissioning and disposal.....	24
5.8	Security.....	24
6.	Transport and storage.....	24
7.	Maintenance.....	24
8.	Mounting.....	24
9.	Dismounting.....	25

## 1. Introduction

This document includes system information and safety requirements for the pressure transmitter DST P92S, which have to be considered and fulfilled within the overall safety application.

It shall be used as input for the:

- development of the overall safety application.
- overall installation and commissioning planning.
- overall safety validation planning.
- overall operation, maintenance and repair planning.

## 2. General information

### 2.1 Contact

Danfoss A/S  
 Industrial Automation  
 DK-6430 Nordborg  
 Denmark  
 www.ia.danfoss.com  
 E-mail: technical support\_IA@danfoss.com

### 2.2 Used symbols and formats



**REQUIREMENT:**  
 Requirement which shall be adhered to maintain safe system operations.



**RECOMMENDATION:**  
 Recommendation on how to handle certain aspects of requirements.



**WARNING:**  
 Warning of faults and errors during the application development.



**NOTE:**  
 A note provides additional and important information of the system behavior.

### 2.3 Reference

No.	Description
/1/	International standard IEC 61508:2010 Functional safety of electrical, electronic and programmable electronic safety-related systems
/2/	Safety standard EN ISO 13849-1:2015 Safety of machinery - Safety-related parts of control systems
/3/	Siemens standard SN 29500: Failure rates of components
/4/	EMC standard EN 61000-4-5:2005 Electromagnetic Compatibility; testing and measurement techniques - Surge immunity test
/5/	Safety standard ISO 25119:2010 / EN 16590:2014 Tractors and machinery for agriculture and forestry - Safety-related parts of control system

## 2.4 Abbreviations

Abbreviation	Description
AgPL	Agricultural Performance Level: Safety classification according to ISO 25119 / EN 16590
CCF	Common Cause Failure
CRC	Cyclic Redundancy Check
DC	Diagnostic Coverage
DFB	Digital Feedback
DTI	Diagnostic Test Interval
ECU	Electronic Control Unit
EEPROM	Electrically Erasable Programmable ROM
EMC	Electromagnetic Compatibility
FRT	Fault Reaction Time
FTT	Fault Tolerance Time
FS	Full Scale
GND	Ground
HW	Hardware
I/O	Input / Output
MDT	Mean Downtime
MTBF	Mean Time Between Failure
MTTFd	Mean Time To dangerous Failure
MTTR	Mean Time To Restoration
PFH	Probability of dangerous Failure per Hour
PL	Performance Level: Safety classification according to EN ISO 13849
PST	Process Safety Time
RAM	Random Access Memory
ROM	Read Only Memory
SFF	Safe Failure Fraction
SIL	Safety Integrity Level: Safety classification according to IEC 61508
SMM	Shadow Memory Module (if existing)
SN	Siemens Standard
SRL	Software Requirement Level
SW	Software
TBD	To be determined / to be defined
VCC	Positive voltage supply connection
VFB	Voltage Feedback
VSRC	Valid Safety Relevant Configuration

### 3. Qualification tests

#### 3.1 Compliance information

Standard	Description	Parameter
	Conformity	See EU Declaration of conformity
KBA (Kraftfahrt-Bundesamt)	Certification Requirement in accordance to the EC type-approval of the Kraftfahrt-Bundesamt (KBA) - Federal Motor Transport Authority: All vehicle types with a 12 V respectively 24 V - electrical wiring and battery(-) at the body	According UN ECE Regulation No. 10
See also Functional Safety Classification on page 9		

#### 3.2 Electromagnetic and electrical tests

##### Electrical Safety

Standard	Test description	Test parameter	Current variant	Ratiometric voltage variant
Danfoss reference	Supply voltage	Current variant: Operation with $U_{max} = 32V$ DC and $U_{min} = 9V$ DC for a duration of 60 min. each.  Ratiometric voltage variant: Operation with $U_{max} = 5.5V$ DC and $U_{min} = 4.5V$ DC for a duration of 50 min. each	x	x
Danfoss reference	Starting profile switch-on hysteresis	Overvoltage and hysteresis: $U_{Test} = U_{max} + 3\%$ $t = 5$ min.  Undervoltage and hysteresis: $U_{Start} = U_{nom}$ $\Delta U = 0.1V$ $U_{min} = U_{switch-off}$ $t$ at $U_{switch-on} = 5$ min.	x	x
Danfoss reference	Broken cable supply lines	Interruption of supply lines: Current variant: $U_{max} = 32V$ $U_{min} = 9V$  Ratiometric voltage variant: $U_{max} = 5.5V$ $U_{min} = 4.5V$  $t = 60$ sec.	x	x
Danfoss reference	Short circuits	Output signals to VCC or GND in each case  $t = 60$ sec.	x	x
Danfoss reference ISO 16750-2: 2012-11	Polarity Protection	Change supply polarity: $t = 5$ min. Current variant: No current limitation of supply necessary  Ratiometric voltage variant: Current limiting of supply to 2A	x	x

Standard	Test description	Test parameter	Current variant	Ratiometric voltage variant
Danfoss reference	Current consumption	Supply current consumption without load: Current variant: $I_{\max} \leq 50 \text{ mA}$  Ratiometric voltage variant: $I_{\max} \leq 20 \text{ mA}$	x	x
Danfoss reference	Load test	48 hours at minimum temperature: 12 hours without operating, 36 hours with operating $U_{\min}$ and $I_{\min}$  48 hours at maximum temperature with operation $U_{\max}$ and $I_{\max}$	x	x
Danfoss reference ISO 16750-2: 2012-11	Insulation Resistance	Unpowered; 500V DC; 60 sec.; 50% rh; 35 °C; between Connector pins and electric conductive housing without galvanic contact.  Insulation resistance > 10 MΩ	x	x

## CE Conformity (EMC)

Standard	Test Description	Test Parameter	Current variant	Ratiometric voltage variant
DIN EN 61000-6-3 DIN EN 61326 DIN 61326-2-3	Emission	Conducted emission: 150 kHz to 30 MHz  Radiated emission: 30 MHz to 1 GHz	x	x
DIN EN 61000-4-2:2009-12 DIN EN 61326-1	Electrostatic Discharge (ESD)	Direct discharge: Contact discharge: $\pm 2 \text{ kV}, \pm 4 \text{ kV}$  Air discharge: $\pm 2 \text{ kV}, \pm 4 \text{ kV}, \pm 8 \text{ k}$  10 discharges per test point	x	x
DIN EN 61000-4-2: 2009-12 DIN EN 61326-1	Electrostatic Discharge (ESD)	Indirect discharge: (horizontal coupling-plate)  Contact discharge: $\pm 2 \text{ kV}; \pm 4 \text{ kV}$  15 discharges per test point	x	x
DIN EN 61000-4-2: 2009-12 DIN EN 61326-1	Electrostatic Discharge (ESD)	Indirect discharge: (vertical coupling-plate)  Contact discharge: $\pm 2 \text{ kV}; \pm 4 \text{ kV}$  15 discharges per test point	x	x
DIN EN 61000-4-3: 2011-04 DIN EN 61326-1 DIN EN 61326-2-3	Immunity	Immunity radio frequency: 80 MHz to 1 GHz (10 V/m) 1.4 GHz to 2.0 GHz (3 V/m) 2.0 GHz to 2.7 GHz (1 V/m)  3 m, horizontal and vertical	x	x
DIN EN 61000-4-4: 2013-04 DIN EN 61326-1 DIN EN 61326-2-3	Burst	Test voltage: Supply lines: $\pm 2 \text{ kV}$ Data lines: $\pm 1 \text{ kV}$ Duration: 5 min. Pulse form: 5/50 ns Frequency: 5 kHz Polarity: positive and negative	x	x

Standard	Test Description	Test Parameter	Current variant	Ratiometric voltage variant
DIN EN 61000-4-5: 2007-06 DIN EN 61326-1 DIN 61326-2-3	Surge	Symmetrical coupling (L-N): Supply lines: $\pm 0.5$ kV; $\pm 1$ kV Coupling: $2 \Omega / 18 \mu\text{F}$  Unsymmetrical coupling (L-PE, N-PE, LN-PE): Supply lines: $\pm 0.5$ kV; $\pm 1$ kV, $\pm 2$ kV Signal lines: not required, cable length <30 m  Coupling: $12 \Omega / 9 \mu\text{F}$  Number of repeats: 5	x	-
DIN EN 61000-4-6: 2014 DIN EN 61326-1 DIN EN 61326-2-3	Immunity	Conducted disturbances 0.15 MHz – 80 MHz, 3 V, 80% AM sine wave 1 kHz	x	x
DIN EN 61000-4-8 DIN EN 61326-1 DIN EN 61326-2-3	Power Frequency Magnetic Fields	50 Hz / 60 Hz 30 A/m 60 sec. for each axis	x	x
DIN EN 61000-4-8 DIN EN 61326-3-1 DIN EN 61326-1 DIN EN 61326-2-3	Power Frequency Magnetic Fields	50 Hz / 60 Hz 30 A/m 60 sec. for each axis	x	x

**EMC (Automotive)**

Standard	Test Description	Test Parameter	Current variant	Ratiometric voltage variant
CISPR 25/ECE R10	Emission	Artificial network (AN): 150 kHz to 108 MHz, 1 m, 120 kHz bandwidth class 3  Antenna measurement (RE): 160 kHz to 30 MHz, 1 m, 9 kHz bandwidth class 4 30MHz to 1 GHz, 1 m, 120 kHz bandwidth class 3 1 GHz to 2.5 GHz, 1 m, 120 kHz bandwidth class 5	x	x
ISO 11452-2: 2004-11	Immunity	Absorber lined chamber: 200 MHz to 2 GHz, 200 V/m CW, AM (1 kHz/80%), PM (577 us duration, 217 Hz repetition rate)	x	x
ISO 11452-4: 2011-12	Immunity	BCI: 20 MHz to 400 MHz, 200 mA, AM, (1 kHz, 80%)	x	x
ISO 7637-2: 2004-09	Emission	Transient emissions on supply cables (12 V system) Severity level:III: +75 V, -100 V	x	-
ISO 7637-2: 2004-09	Emission	Transient emissions on supply cables (24 V system) Severity level III: +150 V, -450 V	x	-
ISO 7637-2: 2004-09	Road vehicles, electrical disturbance by conduction and coupling (data, signal), test level 4 Test level 4 for 12 V and 24V systems	Pulse 1 (12 V system): -150 V, 5000 pulses Severity level: IV	x	-
ISO 7637-2: 2004-09	Road vehicles, electrical disturbance by conduction and coupling (data, signal), test level 4 Test level 4 for 12 V and 24V systems	Pulse 1 (24 V system): -600 V, 5000 pulses Severity level: IV	x	-
ISO 7637-2: 2004-09	Road vehicles, electrical disturbance by conduction and coupling (data, signal), test level 4 Test level 4 for 12 V and 24V systems	Pulse 2a (12 V system): +50 V, 5000 pulses Severity level: IV	x	-

Standard	Test Description	Test Parameter	Current variant	Ratiometric voltage variant
ISO 7637-2: 2004-09	Road vehicles, electrical disturbance by conduction and coupling (data, signal), test level 4 Test level 4 for 12 V and 24V systems	Pulse 2a (24 V system): +50 V, 5000 pulses Severity level: IV	x	-
ISO 7637-2: 2004-09	Road vehicles, electrical disturbance by conduction and coupling (data, signal), test level 4 Test level 4 for 12 V and 24V systems	Pulse 2b (12 V system): +10 V, 10 pulses Severity level: IV	x	-
ISO 7637-2: 2004-09	Road vehicles, electrical disturbance by conduction and coupling (data, signal), test level 4 Test level 4 for 12 V and 24V systems	Pulse 2b (24 V system): +20 V, 10 pulses Severity level: IV	x	-
ISO 7637-2: 2004-09	Road vehicles, electrical disturbance by conduction and coupling (data, signal), test level 4 Test level 4 for 12 V and 24V systems	Pulse 3a (12 V system): -150 V, 1 hour Severity level: IV	x	-
ISO 7637-2: 2004-09	Road vehicles, electrical disturbance by conduction and coupling (data, signal), test level 4 Test level 4 for 12 V and 24V systems	Pulse 3a (24 V system): -200 V, 1 hour Severity level: IV	x	-
ISO 7637-2: 2004-09	Road vehicles, electrical disturbance by conduction and coupling (data, signal), test level 4 Test level 4 for 12 V and 24V systems	Pulse 3b (12V system):+100 V, 1 hour Severity level: IV	x	-
ISO 7637-2: 2004-09	Road vehicles, electrical disturbance by conduction and coupling (data, signal), test level 4 Test level 4 for 12 V and 24V systems	Pulse 3b (24 V system):+200 V, 1 hour Severity level: IV	x	-
ISO 7637-2: 2004-09	Road vehicles, electrical disturbance by conduction and coupling (data, signal), test level 4 Test level 4 for 12 V and 24V systems	Pulse 4 (12V system):-7 V, 1 pulse Severity level: IV	x	-
ISO 7637-2: 2004-09	Road vehicles, electrical disturbance by conduction and coupling (data, signal), test level 4 Test level 4 for 12 V and 24V systems	Pulse 4 (24V system):-16 V, 1 pulse Severity level: IV	x	-
ISO 7637-3: 2007-07	Immunity	Capacitive coupling (CCC) 12 V system test level: IV (-110 V) Test ime: 10 min.  24 V system Test level: IV (-150 V) test time: 10 min.	x	x



Standard	Test Description	Test Parameter	Current variant	Ratiometric voltage variant
ISO 7637-3: 2007-07	Immunity	Capacitive coupling (CCC) 12 V system test level: IV (+75 V) Test ime: 10 min.  24 V system Test level: IV (+150 V) test time: 10 min.	x	x
ISO 7637-3: 2007-07	Immunity	Capacitive coupling (ICC) 12 V system test level: IV (-110 V) Test ime: 10 min.  24 V system Test level: IV (-150 V) test time: 10 min.	x	x
ISO 7637-3: 2007-07	Immunity	Capacitive coupling (ICC) 12 V system test level: IV (+75 V) Test ime: 10 min.  24 V system Test level: IV (+150 V) test time: 10 min.	x	x
CISPR 25	Emission	Conducted emission 150 kHz to 108 MHz	x	x
ISO 10605: 2008-07	Electrostatic Discharge (ESD)	Powered-up test wit direct discharge: - contact discharge: $\pm 2$ kV, $\pm 4$ kV, $\pm 6$ kV, $\pm 8$ kV  - air discharge $\pm 4$ kV, $\pm 8$ k $\pm 15$ kV  3 discharges per test point	x	x
ISO 10605: 2008-07	Electrostatic Discharge (ESD)	Powered-up test wit indirect discharge: - contact discharge: $\pm 2$ kV, $\pm 4$ kV, $\pm 6$ kV, $\pm 8$ kV  50 discharges per test point	x	x
ISO 10605: 2008-07	Electrostatic Discharge (ESD)	Unpowered-up test wit direct discharge: - contact discharge to pins and connectors: $\pm 2$ kV, $\pm 4$ kV  3 discharges per test point	x	x
ISO 10605: 2008-07	Electrostatic Discharge (ESD)	Unpowered-up test wit direct discharge: - air discharge to surface: $\pm 4$ kV, $\pm 8$ k $\pm 15$ kV  3 discharges per test point	x	x

**EMC (Functional Safety with Normal Condition)**

Standard	Test Description	Test Parameter	Current variant	Ratiometric voltage variant
DIN EN 61000-4-2: 2009-12 DIN EN 61326-3-1 DIN EN 61326-1 DIN EN 61326-2-3	Electrostatic Discharge (ESD)	Direct discharge: Contact discharge: $\pm 6$ kV  Air discharge: $\pm 2$ kV, $\pm 4$ kV, $\pm 8$ kV  10 discharges per test point	x	x
DIN EN 61000-4-2: 2009-12 DIN EN 61326-3-1 DIN EN 61326-1 DIN EN 61326-2-3	Electrostatic Discharge (ESD)	Indirect discharge (Horizontal coupling-plate):  Contact discharge: $\pm 6$ kV  15 discharges per test point.	x	x
DIN EN 61000-4-2: 2009-12 DIN EN 61326-3-1 DIN EN 61326-1 DIN EN 61326-2-3	Electrostatic Discharge (ESD)	Indirect discharge (Vertical coupling-plate):  Contact discharge: $\pm 6$ kV  15 discharges per test point.	x	x
DIN EN 61000-4-3: 2011-04 DIN EN 61326-3-1 DIN EN 61326-1 DIN EN 61326-2-3	Immunity	80 MHz to 1.0 GHz (20 V/m) 1.4 GHz to 2.0 GHz (10 V/m) 2.0 GHz to 2.7 GHz (3 V/m)	x	x
DIN EN 61000-4-3: 2013-04 DIN EN 61326-3-1 DIN EN 61326-1 DIN EN 61326-2-3	Burst	Supply: $\pm 3$ kV (5/50 ns, 5 kHz) Signal: $\pm 2$ kV (5/50 ns, 5 kHz)	x	x
DIN EN 61000-4-5: 2007-06 DIN EN 61326-3-1 DIN EN 61326-1 DIN EN 61326-2-3	Surge	Symmetrical coupling (L-N): Supply lines: $\pm 0.5$ kV, $\pm 1$ kV Coupling: $2 \Omega / 18 \mu\text{F}$  Unsymmetrical coupling (L-PE, N-PE, L-N-PE): Supply lines: $\pm 0.5$ kV, $\pm 1$ kV, $\pm 2$ kV Signal lines: not required for cable length < 30 m Coupling: $12 \Omega / 9 \mu\text{F}$  Number of repeats: 5	x	x
DIN EN 61000-4-6: 2014 DIN EN 61326-3-1 DIN EN 61326-1 DIN EN 61326-2-3	Immunity	Conducted disturbance 0.15 MHz - 80 MHz 10 V 80% AM sine wave 1 kHz	x	x
DIN EN 61326-3-1 DIN EN 61326-1 DIN EN 61326-2-3 DIN EN 61000-4-29	Voltage Dips	$V_{dip}$ : 40% $T_d$ : 10 ms $T_r$ : 10 s Number of repeats: 3	x	x
DIN EN 61326-3-1 DIN EN 61326-1 DIN EN 61326-2-3 DIN EN 61000-4-29	Short Interruptions	$V_{dip}$ : 100% $T_d$ : 20 ms $T_r$ : 10 s Number of repeats: 3	x	x

**EMC (Functional Safety with Fail-safe Condition)**

Standard	Test Description	Test Parameter	Current variant	Ratiometric voltage variant
DIN EN 61000-4-2: 2009-12 DIN EN 61326-3-1 DIN EN 61326-1 DIN EN 61326-2-3	Electrostatic Discharge (ESD)	Direct discharge: Contact discharge: $\pm 6$ kV  Air discharge: $\pm 2$ kV, $\pm 4$ kV, $\pm 8$ kV  10 discharges per test point	x	x
DIN EN 61000-4-2: 2009-12 DIN EN 61326-3-1 DIN EN 61326-1 DIN EN 61326-2-3	Electrostatic Discharge (ESD)	Indirect discharge (Horizontal coupling-plate):  Contact discharge: $\pm 6$ kV  15 discharges per test jpoint.	x	x
DIN EN 61000-4-2: 2009-12 DIN EN 61326-3-1 DIN EN 61326-1 DIN EN 61326-2-3	Electrostatic Discharge (ESD)	Indirect discharge (Vertical coupling-plate):  Contact discharge: $\pm 6$ kV  15 discharges per test jpoint.	x	x
DIN EN 61000-4-3: 2011-04 DIN EN 61326-3-1 DIN EN 61326-1 DIN EN 61326-2-3	Immunity	80 MHz to 1.0 GHz (20 V/m) 1.4 GHz to 2.0 GHz (10 V/m) 2.0 GHz to 2.7 GHz (3 V/m)	x	x
DIN EN 61000-4-3: 2013-04 DIN EN 61326-3-1 DIN EN 61326-1 DIN EN 61326-2-3	Burst	Supply: $\pm 3$ kV (5/50 ns, 5 kHz) Signal: $\pm 2$ kV (5/50 ns, 5 kHz)	x	x
DIN EN 61000-4-5: 2007-06 DIN EN 61326-3-1 DIN EN 61326-1 DIN EN 61326-2-3	Surge	Symmetrical coupling (L-N): Supply lines: $\pm 0.5$ kV, $\pm 1$ kV Coupling: $2 \Omega / 18 \mu\text{F}$  Unsymmetrical coupling (L-PE, N-PE, L-N-PE): Supply lines: $\pm 0.5$ kV, $\pm 1$ kV, $\pm 2$ kV Signal lines: not required for cable length < 30 m Coupling: $12 \Omega / 9 \mu\text{F}$  Number of repeats: 5	x	x
DIN EN 61000-4-6: 2014 DIN EN 61326-3-1 DIN EN 61326-1 DIN EN 61326-2-3	Immunity	Conducted disturbance 0.15 MHz - 80 MHz 10 V 80% AM sine wave 1kHz	x	x
DIN EN 61326-3-1 DIN EN 61326-1 DIN EN 61326-2-3 DIN EN 61000-4-29	Voltage Dips	$V_{\text{dip}}$ : 40% $T_{\text{d}}$ : 10 ms $T_{\text{r}}$ : 10 s Number of repeats: 3	x	x
DIN EN 61326-3-1 DIN EN 61326-1 DIN EN 61326-2-3 DIN EN 61000-4-29	Short Interruptions	$V_{\text{dip}}$ : 100% $T_{\text{d}}$ : 20 ms $T_{\text{r}}$ : 10 s Number of repeats: 3	x	x

### 3.3 Environmental qualification

Standard	Test Description	Test Parameter	Current variant	Ratiometric voltage variant
DIN EN 60068-2-6: 2008-10 DIN EN 60068-2-14: 2010-04	Environmental testing - Vibration (sinusoidal) with temperature profile	5 Hz to 2000 Hz, 20 g 5 hours for each axis, -40 °C to + 125 °C, 2 temperature cycles per axis, directions: ±x, ±y, ±z	x	x
DIN EN 60068-2-31: 2008 ISO 16750-3: 2012-12	Environmental testing: Free fall	1 m free fall on concrete ground, 6 axes	x	x
DIN EN 60068-2-14: 2009 DIN EN 60068-2-64: 2008 ISO 16750-3: 2012-12	Road vehicles - Environmental conditions and testing for electrical and electronic equipment: Mechanical loads - Random vibration - Test VII	10 Hz to 2000 Hz, broadband random, 32 hours for each axis, -40 °C to +85 °C, 4 temperature cycles per axes See ISO 16750-3:2012-12 clause 4.1.2.7 directions: ±x, ±y, ±z	x	x
DIN EN 60068-2-27: 2009	Environmental testing: Shock	50 g / 11 ms, half-sine wave, 3 shocks per direction directions: ±x, ±y, ±z	x	x
DIN EN 60068-2-27: 2009	Environmental testing: Bump	Bump, 30 g / 6 ms, half-sine wave, 3 shocks per direction, directions: ±x, ±y, ±z	x	x
DIN EN 60068-2-2: 2008-05 ISO 16750-4: 2010-4	Environmental testing: Cold storage	24 hours with -40 °C	x	x
DIN EN 60068-2-2: 2008-05 ISO 16750-4: 2010-04	Environmental testing: Dry heat (storage)	96 hours with 85 °C	x	x
IEC 60068-2-14: 2009 DIN EN 60068-2-14: 2010-04	Environmental testing: Change of temperature Na	-40 °C --> +85 °C, 100 cycles, duration time 1 hour, temperature changes 10 seconds	x	x
IEC 60068-2-14: 2009 DIN EN 60068-2-14: 2010-04	Environmental testing: Change of temperature Na	-40 °C --> +85 °C, 10 cycles	x	x
IEC 60068-2-14: 2009 DIN EN 60068-2-14: 2010-04	Environmental testing: Life test, thermal shock	Weibull test according ISO 16750-1: 2003 $\Delta T_{\text{prac}}$ : 60 Kelvin Frequency of temperature differences: twice a day Number of days in the year: 365 days Life time: 10 years	x	x
ISO 16750-4: 2010-04	Environmental testing: Ice water shock	Cycles: 10 $T_{\text{max}}$ : 85 °C Duration time: 5 min.	x	x
IEC 60068-2-30: 2005 DIN EN 60068-2-30: 2005	Environmental testing: Damp heat cyclic	+25 °C to 55 °C with 93% r.h. 6 cycles (each cycle 24 hours)	x	x
DIN EN 60068-2-78: 2014-02	Environmental testing: Damp heat constant	21 days with 40 °C and 93% r.h.	x	x
IEC 60068-2-60: 1996-09 ISO 16750-4: 2010-04	Flowing mixed gas corrosin test	Sulfur dioxide SO <sub>2</sub> , hydrogen sulfide H <sub>2</sub> S, nitrous oxide NO <sub>2</sub> , Chlorine Cl <sub>1</sub>	x	x
DIN EN 60529: 2000-09 DIN 40050-9: 1993-05	IP protection classes	IP67/IP69K, IP6KX Dust tight according to ISO 12103-1 Arizona test dust A2 fine	x	x
ISO 16750-5: 2010-04	Chemical resistance	Gas / petrol, diesel, cleaner solvent, antifreeze, urea, battery fluid, brake fluid, engine oil, hydraulic oil	x	x

#### 4. System information

The DST P92S is designed for the operation in working machinery and further suitable application areas and qualified especially for use under harsh conditions.

The pressure transmitter is a passive intelligent sensor. Its basically function is to convert the physical quantity “pressure” to an electrical signal.

Available output types:

Current variant:

Current output signal. This variant provides two opposing current outputs 4 – 20 mA and 20 – 4 mA.

Ratiometric voltage variant:

Ratiometric voltage output signal. This variant provides two opposing ratiometric voltage outputs  $10\% \cdot VCC - 90\% \cdot C$  and  $90\% \cdot VCC - 10\% \cdot VCC$



#### 4.1 Functional safety classification

The DST P92S has the following functional safety classification and parameters:

Standard	Description	Parameters of current variant	Parameters of the ratiometric voltage variant
IEC 61508/1/ (see “Reference” on page 3)	Safety Integrity Level (SIL)	2	2
	Architecture	1oo1 (single channel)	1oo1 (single channel)
	Hardware Failure Tolerance (HFT)	0	0
	Safety-related subsystem	Type B	Type B
	Safe Failure Fraction (SFF)	95.8% *	93.1%*
	Average frequency of dangerous failure per hour (PFH)	$6.1 \times 10^{-9}$ 1/h	$4.9 \times 10^{-9}$ 1/h
EN ISO 13849-1 /2/ (see “Reference” on page 3)	Performance Level (PL)	d	d
	Category (Cat.)	2	2
	Avg. Diagnostic Coverage ( $DC_{avg}$ )	94.7% *	91.0%*
	Common Cause Failures (CCF)	70 points	70 points
	Mean Time To dangerous Failure ( $MTTF_D$ )	981 years	2090 years
ISO 25119/EN 16590/5/(see “Reference” on page 3)	Agricultural Oerformance level (AgPL)	d	d
	Category (Cat)	2	2
	Avg. Diagnostic Coverage ( $DC_{avg}$ )	94.7%*	91.0%*
	Mean Time to Dangerous Failure ( $MTTF_{dc}$ )	981 years	2090 years
	Software Requirement Level (SRL)	Not relevant	Not relevant

\* with an external monitoring according to this safety guide

## 4.2 Technical data

### Pressure

Parameter	Min.	Max.
Nominal pressure range	0 - 10 bar	0 - 1200 bar
Overload (depending on pressure range)	50 bar	2400 bar
Installation torque of the pressure connection	15 Nm	35 Nm

### Current output

Parameter	Min.	Max.
Current within nominal pressure range	4 mA	20 mA
Current at off-state	0 mA	2 mA
Current accuracy output SIG1 (depending on ambient temperature)	1% FS	2.5 % FS
Tolerance for plausibility check current output SIG1 + output SIG2	2.5 % FS	Depending on application and ECU tolerance: e.g. 3%FS
Current load (depending on power supply)	0 Ω	1325 Ω
Electrical protection	Short circuit protected (signal on GND/VCC)	



#### NOTE

- The accuracy is only guaranteed under reference conditions ( $T_{\text{medium}} = T_{\text{ambient}}$ ).
- The maximum current load depends on the power supply and is calculated by  $R_{\text{MAX}} = (+UB - 5.5 V) / 0.02 A$ .

### Operating area for current outputs of the current variant

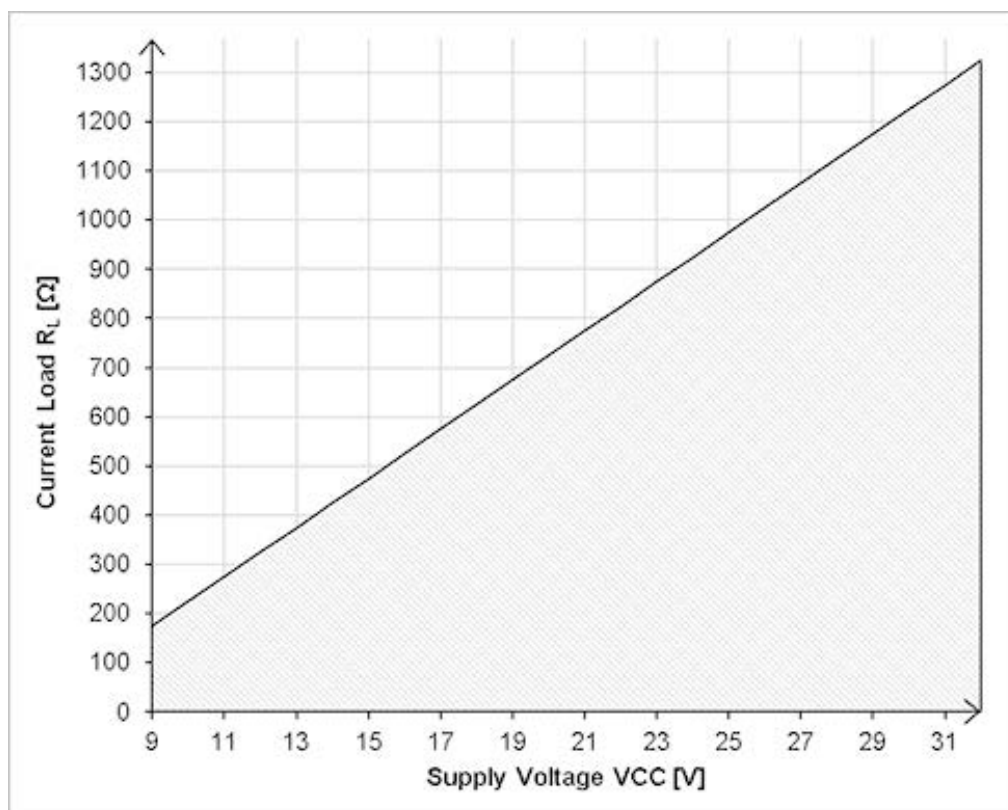

**WARNING**

If the application operates at maximum load limit, pressures above 100% FS can not be displayed!

**Output of ratiometric voltage variant**

Parameter of the ratiometric voltage outputs

Parameter	Min.	Max.
Relative voltage within nominal pressure range	10%* VCC	90%* VCC
Relative voltage at off-state	0 V	5%* VCC
Accuracy of output SIG1 (depending on ambient temperature)	1% FS	2.5% FS
Accuracy plausibility check output SIG1 + output SIG2 (depending on ambient temperature)	2.5% FS	Depending on application and ECU tolerance: e.g. 3% FS
Load Resistance	≥ 10 kΩ	-
Load current	-	1.3 mA
Capacitive load	-	10 nF
Electrical protection	Short circuit protected (signal on GND/VCC)	

**Power supply**

Parameter	Min.	Max.
Current variant: Voltage supply (power supply pin VCC)	9 V DC	32 V DC
	Supply lines inverse-polarity protected	
Ratiometric voltage variant: Voltage supply (power supply pin VCC)	4.5 V DC	5.5 V DC
	Supply lines inverse-polarity protected with current limit of up to 2 A	

**General accuracy**

Parameter	Min.	Max.
Linearity, pressure hysteresis and repeatability	-	0.5% FS
Long-run stability	-	0.2% FS

**Timing**

Parameter	Min.	Max.
Startup	-	40 ms
Response time	-	2 ms

**Mechanical data**

Component	Description
Housing	Welded stainless steel
Degree of protection	IP67, IP69K
Electrical connection	M12 DT04
Pressure connection	G $\frac{1}{4}$ , $\frac{1}{4}$ NPT, 7/16 - 20 UNF and 9/16 - 18 UNF
Installation torque	Maximum 35 Nm
Material with medium contact	EN/DIN 1.4548 / FK
Material housing	EN/DIN 1.4301
Material diaphragm	EN/DIN 1.4548
Material connector	PBT-GF30
Dimensions (W x H x D)	DST P92S G $\frac{1}{4}$ with M12x1 PBT: 54 x 22 x 26 mm (wrenchsize 22) DST P92S G $\frac{1}{4}$ with DT04x1 PBT: 65 x 22 x 26 mm (wrenchsize 22)
Weight	DST P92S with M12x1 PBT: ca. 50 g
Operating chassis temperature Ratiometric voltage variant	-40 °C – 85 °C
Operating chassis temperature Current variant	

**4.3 Technical drawings**

Electrical connection	M1 $\frac{1}{4}$ x1, 5-pole PBT		DT04, 4-pole PBT	
Pressure connection	G $\frac{1}{4}$	$\frac{1}{4}$ NPT	7/16-20 UNF	9/16-18 UNF



#### 4.4 Pin configuration

M12x1	DT04
Pin 1: VCC Power supply Pin 2: SIG2 Inverse pressure signal output Pin 3: GND Common ground Pin 4: SIG1 Pressure signal output Pin 5: - Do not connect	Pin 1: VCC Power supply Pin 2: GND Common ground Pin 2: SIG2 Inverse pressure signal output Pin 4: SIG1 Pressure signal output

#### 4.5 Wiring diagram

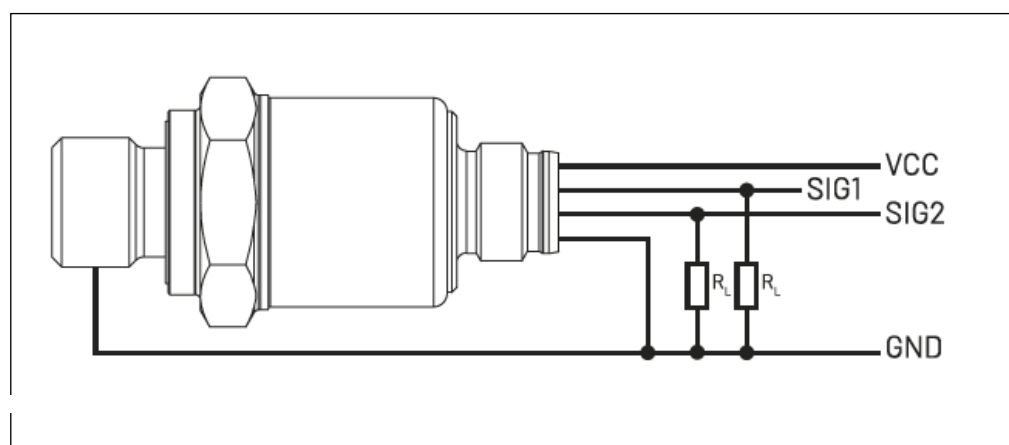

#### 4.6 Safety functions

The pressure transmitter DST P92S executes following safety function:

Safety function	Safety integrity	Error reaction	DTI
safe conversion of the measured pressure into two proportional redundant-opposing current signals or ratiometric voltage signals (0..100 %FS correspond to 4..20 mA or 0..100 %FS correspond to 10% * VCC .. 90% * VCC)	IEC 61508 / SIL-2 EN ISO 13849 / PLd ISO 25119 / AgPId	"Fail safe"	80 ms

#### Safety relevance:

1. Accuracy of the sum of the single current
2. Maximum conversion delay



#### NOTE

The outputs of the DST P92S are not safe by themselves but in combination with a redundant signal processing.

### 4.7 Diagnosis

The DST P92S uses several mechanisms to detect faults in the electronic circuit. Those are realized in a start-up and a cyclic diagnosis.

#### Start-Up Diagnosis

The start-up diagnosis is made once after powering the DST P92S and includes internal tests concerning e.g. the oscillator, the watchdog or any memory. If the start-up diagnosis detects a fault, the "Fail safe" is entered. The DST P92S remains in the safe state.

#### Cyclic Diagnosis

The cyclic diagnosis is made every 30-40ms and includes:

- testing of the temperature sensor element
- testing of the pressure sensor concerning drift, open circuit and short circuit
- testing of the sensor signal range

If the cyclic diagnosis detects a fault, the "Fail safe" is entered as long as the fault is pending.

## 5. Safety requirements

The following diagram shows the pressure transmitter DST P92S is a typical application

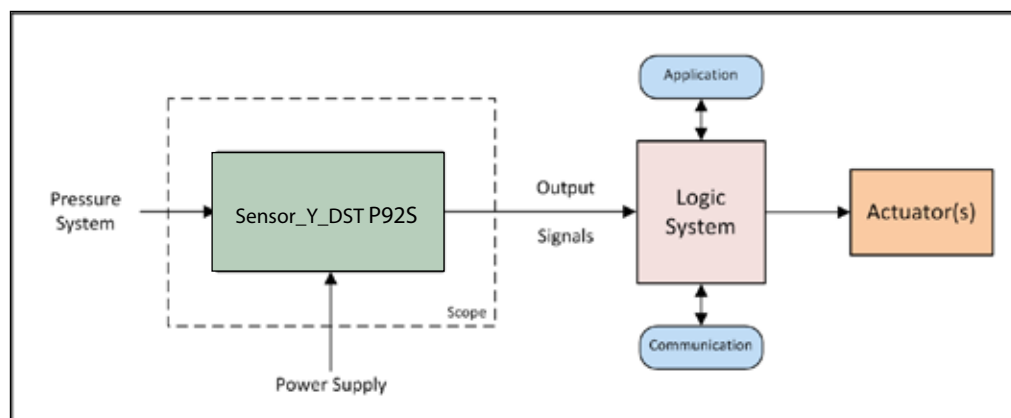

#### NOTE

Information: Safety requirements within this manual are characterized by an identifier like SR\_DST P92S\_<index>. This can be used to trace requirements that shall be followed through the development process of the application.

### 5.1 Known issues



**NOTE**  
There are no known issues for the DST P92S

### 5.2 Instructions and constraints

#### Safety standards



**REQUIREMENT**  
SR\_DST P92S\_001:  
The current national and international safety regulations, laws, and standards for the whole safety lifecycle have to be observed.

#### Proof test interval



**REQUIREMENT**  
SR\_DST P92S\_004:  
A proof test interval of the pressure transmitter DST P92S must be initiated and controlled every 7½ years. As the DST P92S can not be recalibrated, it has to be replaced, if the deviations exceed the maximum tolerances.

#### Qualification of staff



**REQUIREMENT**  
SR\_DST P92S\_002:  
The pressure transmitter DST P92S must be installed and operated by trained, qualified personnel only. The knowledge and the technical implementation of the safety information provided by this manual are imperative for a safe installation and operation.

#### Troubleshooting procedures



**REQUIREMENT**  
SR\_DST P92S\_005:  
A faulty transmitter must be replaced immediately. There is no maintenance or repair procedure provided for the DST P92S

#### Method statement



**REQUIREMENT**  
SR\_DST P92S\_003:  
Before setting the DST P92S into operation for an application it is necessary to read and follow the instructions of this safety manual. The limits of the technical data (see "Technical Data" item 4.2) must be complied within the application.

#### CE Conformity



**REQUIREMENT**  
SR\_DST P92S\_014:  
For CD conformity the following restrictions have to be observed: The length of the cables, which are connected to pressure transmitter, must not exceed 30 m.

### 5.3 Fail Safe

The state fail safe of the pressure transmitter DST P92S

Type of DST P92S	Signal	State fail safe	M12	DT04
Current variant	Output SIG1	Iout < 2 mA	Pin 4	Pin 4
	Output SIG2	Iout < 2 mA	Pin 2	Pin 3
Ratiometric voltage variant	Output SIG1	Uout < 5% * VCC	Pin 4	Pin 4
	Output SIG2	Uout < 5% * VCC	Pin 2	Pin 3

The safe state is entered when the DST P92S recognizes a fault condition.

Both outputs go into the safe state simultaneous.



**NOTE**  
Specification:  
The maximum time between a fault occurrence and the safe state of the DST P92S is 80 ms.



**REQUIREMENT**  
SR\_DST P92S\_006:  
The fault detection cycle of the superordinate logic system must be long enough to detect an error reliably.

Example:

The following time diagram shows the DST P92S in a typical “sensor-logic-actuator” application e.g. with an electronic control unit.

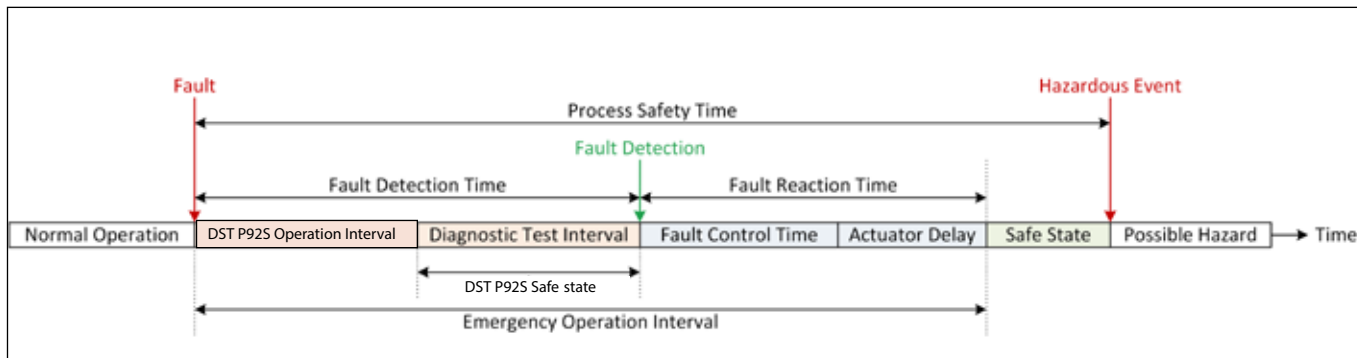

Reset condition



**NOTE**  
Specification:  
If a fault condition isn't pending continuously, the DST P92S will leave the safe state earliest after 60 ms.



**REQUIREMENT**  
SR\_DST P92S\_007:  
The diagnostic test interval of the superordinate logic system must be short enough to detect the safe state reliably.

Restrictions



**WARNING**  
The safe state may not be entered during an over- or under-voltage condition or during startup. Possibly occurring spikes on the outputs have to be ignored.



**REQUIREMENT**  
SR\_DST P92S\_022:  
The superordinate logic system has to consider non-functional operating modes, which do not lead to a safe state.

## 5.4 System

System overview

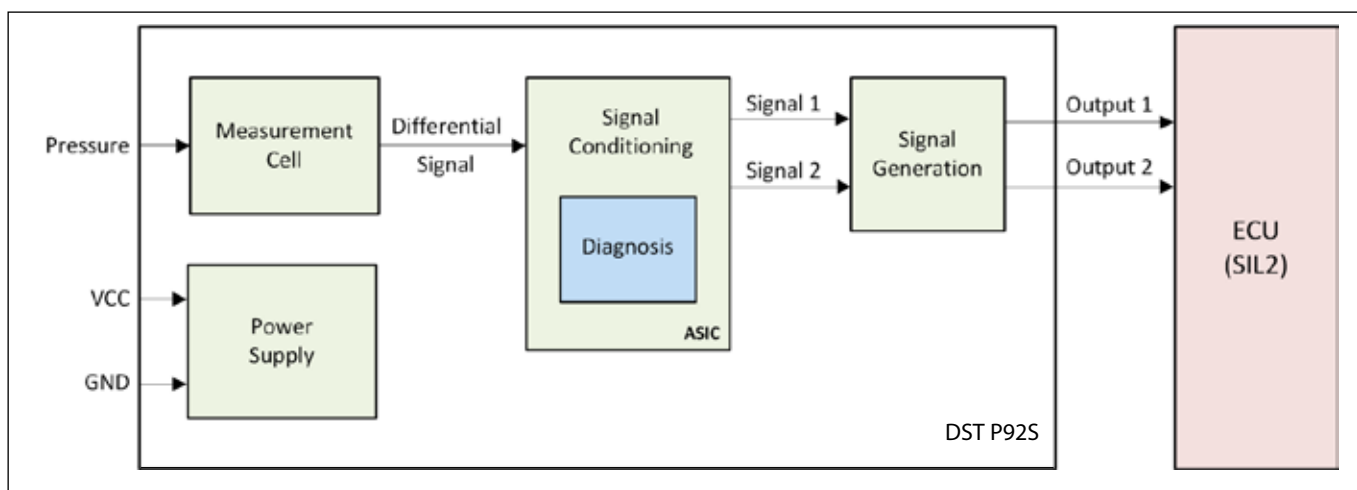

**REQUIREMENT**  
SR\_DST P92S\_008:  
Exceeding the maximum supply voltage of the DST P92S may cause an unsafe operation. Therefore the superordinate logic system has to monitor the sensor power supply.



**REQUIREMENT**  
SR\_DST P92S\_018:  
Take measures to avoid an overvoltage condition at the DST P92S.

**!** **REQUIREMENT**  
 SR\_DST P92S\_009:  
 Running the DST P92S outside its temperature limits may cause an unsafe operation. Therefore the superordinate logic system has to monitor the ambient temperature.

**!** **REQUIREMENT**  
 SR\_DST P92S\_021:  
 The chassis, in which the DST P92S is mounted, has to be connected to the power supply ground, to fulfill the EMC requirements.

**!** **REQUIREMENT**  
 SR\_DST P92S\_019:  
 There have to be taken measures to avoid an over- or under-temperature condition at the DST P92S.

### 5.5 Pressure

The pressure is measured by a welded thin-film capsule, which converts the physical pressure into an electrical signal by resistor full-bridge. An additional temperature meander makes it possible to compensate the signal.

Functional diagram

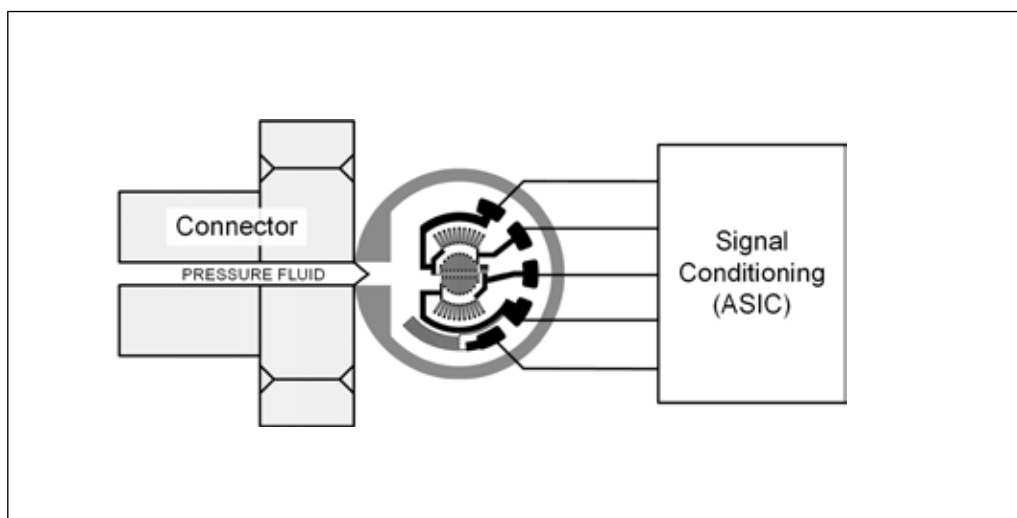

**!** **REQUIREMENT**  
 SR\_DST 92S\_010:  
 Because the radius of the pressure channel of the DST P92S is very small, measures must be taken for the pressure system to prevent its clogging.

**!** **REQUIREMENT**  
 SR\_DST 92S\_024:  
 The thread shall be made of stainless steel and shall be free of lubricant.

**!** **REQUIREMENT**  
 SR\_DST P92S\_011:  
 Running the DST P92S outside its temperature limits may cause an unsafe operation. Therefore, the superordinate logic system has to monitor the pressure medium temperature.

**!** **RECOMMENDATION**  
 Avoid to exceed the specified pressure ranges of the used DSR P92S. For a smooth operation the pressure system should be able to provide a stable non-fluctuating pressure. The accuracy of the pressure measurement is only guaranteed under reference conditions, that means if the medium temperature and the ambient temperature is nearly the same. Therefore measures should be taken to effect this.



**WARNING**

A drift of the measurement cell due to an overpressure as well as an aging-related drift can only be detected at the pressure limits (0 %FS, 100 %FS) of the DST P92S.

**5.6 Outputs**

The outputs of the DST P92S are designed as redundant inverted signals. The inverted signals can be used to establish a redundant signal processing for safety-related applications.

Output signal	Range of current variant	Range of ratiometric voltage variant
SIG1	4 – 20 mA	10% * VCC – 90% * VCC
SIG2	20 – 4 mA	90% * VCC – 10% * VCC

**Signal diagram**

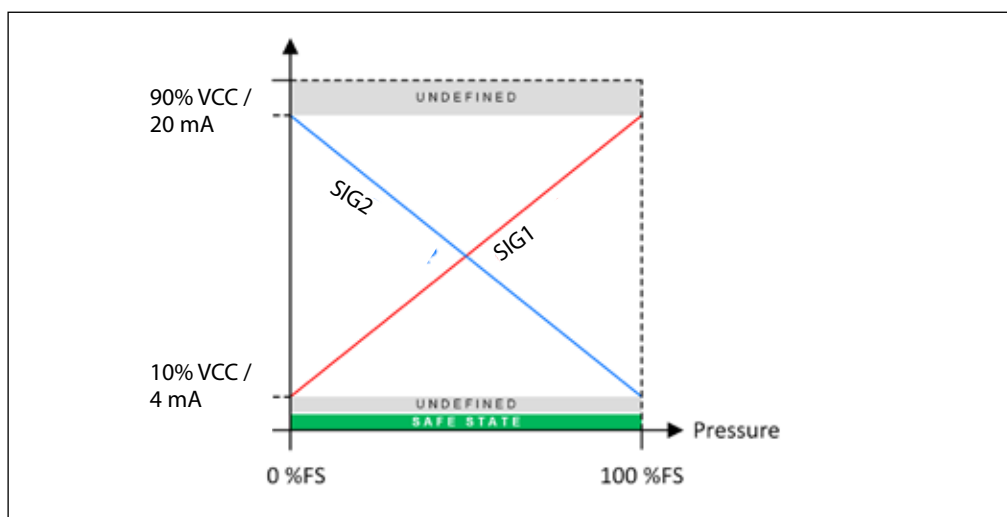

**REQUIREMENT**

SR\_DST P92S\_012:

The superordinate logic system has to provide safety-related input pairs, which fulfill the reservations of the DST P92S outputs (see technical data (see "Technical Data" item 4.2). (Especially the requirements for the minimum and maximum loading of the current outputs have to be observed.)



**REQUIREMENT**

SR\_DST P92S\_013:

The measured pressure is always represented by output 1. Output 2 must only be used for the safety function, as it is not calibrated and temperature compensated.



**REQUIREMENT**

SR\_DST P92S\_020:

The superordinate logic system has to process both output signals simultaneously and to compare them in a meaningful way.



**REQUIREMENT**

SR\_DST P92S\_017

The superordinate logic system has to check, if there is a short circuit between the DST P92S outputs. Depending on the applications, this must be done cyclically or at start-up.



**RECOMMENDATION**

For signal processing the two output values should be accumulated by the application and be compared to predefined limits (e.g. 24 mA ± 3 %FS).

### Outputs of ratiometric voltage variant

With the ratiometric voltage variant the supply and output pins of the signal conditioning are directly connected to the connector.

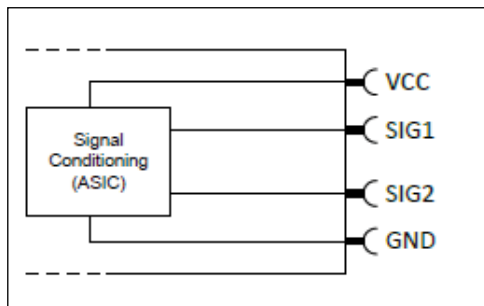

#### REQUIREMENT

SR\_DST P92S\_015:  
A ratiometric voltage value of  $<7.5\% \cdot VCC$  or  $>92.5\% \cdot VCC$  may be the result of a damaged DST P92S. Therefore, the superordinate logic system must be able to check the current range and react on an invalid value.



#### REQUIREMENT

SR\_DST P92S\_025:  
In case of an electronic ground loss (GND), the two output signals have no defined level. The superordinate logic system must perform a plausibility check of the two output signals (See SR\_DST P92S\_020 and SR\_DST\_P92S\_017).

### Output of current variant

With the current variant the signal conditioning is supplied via a DC/DC converter and its outputs are used to generate the current signals.

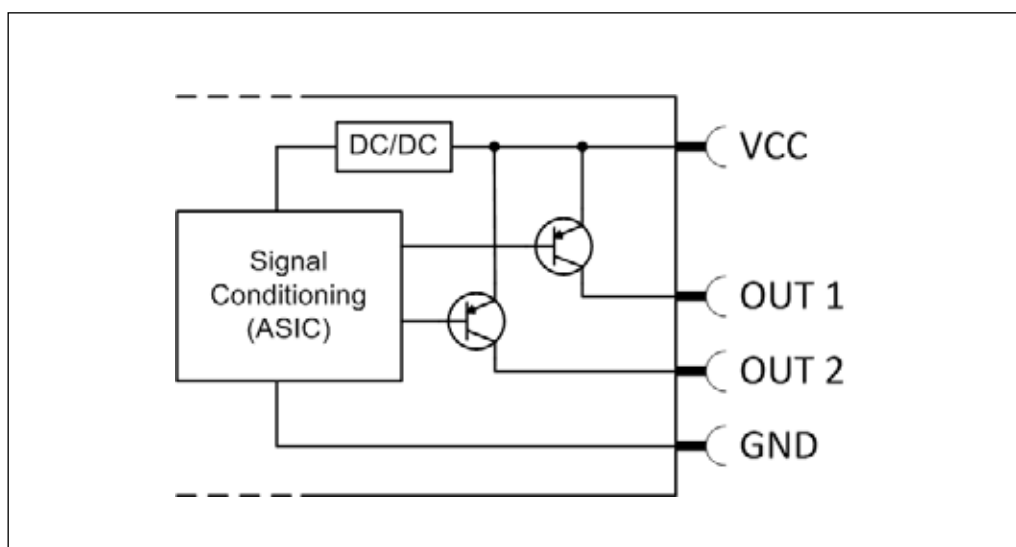

#### REQUIREMENT

SR\_DST P92S\_016:  
A current value  $< 3.5 \text{ mA}$  or  $> 20.5 \text{ mA}$  may be the result of a damaged DST P92S. Therefore the superordinate logic system must be able to check the current range and react on an invalid value.



#### RECOMMENDATION

To check, if there is a short circuit between the DST P92S current outputs, one of them could be additionally loaded, e.g. with a programmable pull-down resistor. The other one should not change its value.



#### RECOMMENDATION

If the inputs of superordinate logic system do not provide suitable load resistors as required in the technical data (see "Technical Data" item 4.2), an additional series resistance can be connected to the wiring. (See "Examples")

### 5.7 Decommissioning and disposal



**NOTE**  
For the DST P92S there has nothing to be considered regarding decommissioning. The disposal of the DST P92S has to be done according to national laws.

### 5.8 Security



**NOTE**  
For the DST P92S there has nothing to be considered regarding security.

## 6. Transport and storage

### Transport

Check the pressure transmitter for possible transport damage.  
Do not use damaged devices.

### Storage

Store the pressure transmitter in its original packaging.  
Remove the packaging only immediately before mounting. The packaging provides protection during storage and transport.

## 7. Maintenance

There is no main tenance or repair procedure provided for the DST P92S (See "Instructions and Constraints" item 5.2).

## 8. Mounting

### Preconditions

- Provide an ESD suitable environment
- Provide a dry and clean environment
- The thread and all sealing faces of the pressure transmitter must be undamaged and clean
- Apply the force to screw the pressure sensor only through the spanner flats provided for this purpose
- Select a cable diameter that matches the cable connector of the mating plug
- Protect the cable end from humidity. Otherwise humidity can intrude into the instrument

See Mechanical Dimensions fir needed space.



**WARNING**  
Danger of serious injury and/or damage to the equipment, when used beyond the specified operative range.

Ensure to select the right type of pressure transmitter according to:

- pressure range
- measurement range
- specific measurement conditions

### Required tools

Torque wrench: Width across flats 22

### How to mount



**WARNING**  
Danger of serious injury from sudden escaping pressurized media.

Before opening any connections, make sure to:

- Disconnect energy source
- Prevent reconnection
- Depressurize the system, including pressure accumulators, lower upheld load or provide compression-resistant support for upheld load, remove residual energy
- Test the system for absence of pressure
- Prevent danger due to adjacent systems components

1. Screw the DST P92S into your system by hand. Do not damage the thread, otherwise a sealing connection cannot be established.
2. Tighten the DST P92S with the torque wrench and a maximal screwing-torque of 35 Nm
3. Connect the connector with opposite plug: Make sure the sealing of the connector is present. Make sure to latch the connector into the opposite plug.
4. Attach the used cables for DST P92S with a cable relief. No force must act on the connector and cables. Do not bend the cable with a radius smaller than 18 mm.



## 9. Dismounting

### Preconditions

- Provide an ESD suitable environment
- The connected pressure transmitter must be cleaned
- Apply the force to screw off the pressure transmitter only through the spanner flats provided for this purpose

### Required tools

Wrench: Width across flats 22

### How to dismount



#### WARNING

Danger of serious injury from sudden escaping pressurized media.

Before opening any connections, make sure to:

- Disconnect energy source
- Prevent reconnection
- Depressurize the system, including pressure accumulators, lower upheld load or provide compression-resistant support for upheld load, remove residual energy
- Test the system for absence of pressure
- Prevent danger due to adjacent systems components

1. Make sure the system is depressurized.
2. Remove cable relief from the cables. Do not damage the cables.
3. Disconnect the connector from mating plug.
4. Screw off DST P92S from your system with the wrench. Do not damage the threads.

Danfoss A/S  
Industrial Automation  
Nordborgvej 81  
DK-6430 Nordborg  
Denmark

[www.ia.danfoss.com](http://www.ia.danfoss.com)

Danfoss can accept no responsibility for possible errors or omissions, inaccuracies, omissions and other printed material. Danfoss reserves the right to alter its products without notice. This also applies to products already in order provided that such alterations can be made without consequential changes being necessary to specifications already agreed. All trademarks in this material are property of the respective companies. Danfoss and the Danfoss logo are trademarks of Danfoss A/S. All rights reserved.