



Substations

DSA 1 MINI Micro Grid

Description

The DSA 1 MINI Micro Grid is a welded district heating station. It is designed to transfer thermal energy from a local or from a district heating network to the heating or a domestic water system in a building. The station comprises devices as well as offers functionalities necessary to meet different district heating network connection conditions.

Applications

The DSA 1 MINI Micro Grid station has been designed to secure high efficiency of the thermal energy transfer, and thus offer the best possible performance as the thermal energy source for a building.

The district heating network, being the primary side, and the heating or the domestic water systems in a building, being the secondary side, may need to be hydraulically separated from each other. To secure this the station comprises a heat exchanger.

The DSA 1 MINI Micro Grid station also offers devices and equipment for controlling and monitoring the contracted flows and temperatures as well as for measuring the used in the building energy. The station design follows the main standards and requirements. Consequently, the stations can cover a wide range of applications in different markets.

Ordering

Product code numbers

Station version 1 - DE

Nominal capacity [kW]*	Type L				Type E			
	Designation with an energy meter or with an insert instead of an energy meter							
	Insert instead of energy meter	Energy meter SONOMETER 40	Insert instead of energy meter	Energy meter SONOMETER 40	Insert instead of energy meter	Energy meter SONOMETER 40	Insert instead of energy meter	Energy meter SONOMETER 40
	DLO0 - LIxxxDE	DLO0 - LSxxxDE	DRO0 - LIxxxDE	DRO0 - LSxxxDE	DLO0 - EIxxxDE	DLO0 - ESxxxDE	DRO0 - EIxxxDE	DRO0 - EIxxxDE
	code		code		code		code	
15*	146B5455	146B5460	146B5475	146B5480	146B5465	146B5470	146B5485	146B5490
30*	146B5456	146B5461	146B5476	146B5481	146B5466	146B5471	146B5486	146B5491
40*	146B5457	146B5462	146B5477	146B5482	146B5467	146B5472	146B5487	146B5492
60*	146B5458	146B5463	146B5478	146B5483	146B5468	146B5473	146B5488	146B5493
75*	146B5459	146B5464	146B5479	146B5484	146B5469	146B5474	146B5489	146B5494

* Nominal capacity

For other capacities the table: "Station version 1 – DE - capacity in reference to the supply and return temperatures" should be consulted.

xxx – length of an insert instead of an energy meter (110 or 190 mm) or the energy meter code (015 or 025)

Station version 2 - AT & P330

Nominal capacity [kW]*	Type L**		Type L***	
	Designation with an energy meter or with an insert instead of an energy meter			
	Insert instead of energy meter	Energy meter SONOMETER 40	Insert instead of energy meter	Energy meter SONOMETER 40
	DUU0 - LIxxxAT	DUU0 - LSxxxAT	DUU0 - LIxxx_P330	DUU0 - LSxxx_P330
	item number		item number	
40*	146B5417	146B5422	148L2795	148L2805
60*	146B5418	146B5423	148L2798	148L2806
75*	146B5419	146B5424	148L2799	148L2807
90*	146B5762	146B5764	148L2800	148L2808
105*	146B5763	861L0430	148L2801	148L2809

* Nominal capacity

For other capacities the table: "Station version 2 – AT & P330 - capacity in reference to the supply and return temperatures" should be consulted.

xxx – length of an insert instead of an energy meter (110, 190 or 260 mm) or the energy meter code (015, 025 or 035)

** Without the application key for the ECL310 controller

*** Including a P330 application key for the ECL310 controller and an adapter for a directly mounted temperature sensor of a heat meter, M10 × 1, L = 27.5 mm

Functions

Operation

The DSA 1 MINI Micro Grid is an indirect type of a station. It uses a plate heat exchanger for the thermal energy transfer purposes and to separate the network from the heating or from the domestic hot water systems in a building. To secure a high efficiency thermal energy transfer water shall not carry air bubbles nor dirt into the heat exchanger. To ensure this the DSA 1 MINI Micro Grid station comprises an air vent and a strainer on the primary side. The heat transfer process must be controlled so that the required temperature of water on the secondary side is achieved. Water temperature is measured using sensors mounted on the primary and on the secondary sides. The readings from the sensors are processed in the controller which translates these into signals that can be used in the actuators of the pressure independent control valves (PICV) with flow limitation or, the optional and available on request, 2-way control valves mounted on the primary side of the station.

Differential pressure control valves with flow limitation can be optionally mounted in stations which shall be delivered with 2-way control valves. Thanks to this setup the differential pressure across 2-way control valves is stabilized securing a high authority of these and the desired precision of flow control. At the same time the contracted flow is never exceeded. A station can be connected to a network if it fulfills the utility company technical conditions. These, amongst other, define the requirements concerning the measuring equipment. Since hot water from a local or from a district heating network is delivered to DSA 1 MINI Micro Grid station at different pressures and temperatures - the water temperature varies based on the outdoor conditions and depending on the season of the year - the quality of the measuring equipment is vital.

The DSA 1 MINI Micro Grid station complies with the requirements by offering on the primary side thermometers and manometers designed particularly for district heating applications.

For more flexibility the station is available with an insert - a piece of pipe - instead of an energy meter which can be selected and installed at a later stage. Naturally, there is a selection of Danfoss energy meters that can be installed in DSA 1 MINI Micro Grid as well.

The station is equipped with shut-off valves for service purposes. The DSA 1 MINI Micro Grid can be combined with a Danfoss domestic hot water (DHW) substation either on the primary or on the secondary side.

After transferring thermal energy from the primary to the secondary side water flows from the heat exchanger through the return lines on the primary side back to the local or the district heating network.

To distribute the thermal energy on the secondary side, pumps circulating water to radiator (HE), floor heating (FH), domestic hot water (DHW) or other systems must be provided, as part of an external equipment.

On the secondary side the DSA 1 MINI Micro Grid station offers a selection of standard and optional items such as safety valves, safety thermostats, strainers with drain valves, connections for expansion vessels, manometers, check valves, shut off valves and thermometers. There is also a range of accessories available to support the connection of the domestic hot water station.

The station is produced in two versions for particular temperature, pressure and connections:

- Station version 1 – DE
- Station version 2 – AT & P330

Depending on the version it can be configured to suit the local connection conditions. The pipes on the primary side may be connected from the left or from the right while the pipes on the secondary side from the bottom or from the top.

Maximum operating parameters

Primary side		Station version 1 – DE	Station version 2 – AT & P330
Maximum supply temperature	TVP	type L: 95 °C type E: 120 °C	type L: 100 °C
Maximum operating pressure	PZP	type L: 16 bar (g) type E: 25 bar (g)	type L: 16 bar (g)
Nominal pressure	PN	type L: 16 type E: 25	type L: 16
Maximum differential pressure	DPP	type L: 12 bar type E: 20 bar	type L: 12 bar
Maximum flow rate	VZP	2,46 m ³ /h at w ≤ 0,9 m/s	3,50 m ³ /h at w ≤ 1,45 m/s
Secondary side			
Maximum supply temperature	TVS	95 °C	100 °C
Maximum operating pressure	PZS	3 bar (g) (safety valve opening)	
Nominal pressure	PN	6	
Maximum flow rate	VZS	3,54 m ³ /h at w ≤ 0,9 m/s	5,05 m ³ /h at w ≤ 0,9 m/s

L – low parameter station, E – high parameter station

Product details

General data

Types / designation

Station version 1 - DE

DSA 1 MINI Micro Grid		
Code	D L / R O/U/L / RYYY L / E I / S XXX DE	
D	controller type	D = Danfoss ECL310
L/R	primary side	L = left
	connection direction	R = right
O / U / L / R	secondary side	O = top (standard)
	connection direction	U = bottom L = left (at primary right) R = right (at primary left)
YYY	capacity in kW	15 kW: 015, 30 kW: 030, 40 kW: 040, 60 kW: 060, 75 kW: 075
L / E	type	L: PN16 / 95°C
		E: PN25 / 120°C
I / S XXX	energy meter	S015 = Sonometer 40 QP 1.5 S025 = Sonometer 40 QP 2.5
	length of the insert mounted instead of energy meter	I110 = insert 110 mm/G 3/4" I190 = insert 190 mm/G 1"
DE	station market code	DE = all markets

Example:

DSA 1 MINI Micro Grid DLO015LS015DE

Station type: DASA 1 MINI Micro Grid with ECL 310 controller, primary side connection on the left, secondary side connection on the top, nominal capacity 15 kW, low parameter station type L, comprising an energy meter Sonometer 40 QP 1.5, station version 1 - DE

The DSA 1 MINI station may be delivered in different configurations. These can be defined using the online tool: heatselector.danfoss.com

Station version 2 - AT & P330

DSA 1 MINI Micro Grid		
Code	D U U YYY L I/S XXX AT / P330	
D	controller type	D = Danfoss ECL310
U	primary side connection direction	U = bottom
U	secondary side connection direction	U = bottom
YYY	capacity in kW	40 kW: 040, 60 kW: 060, 75 kW: 075, 90 kW: 090, 105 kW: 105
L	type	L: PN16 / 100°C
I / S XXX	energy meter	S015 = Sonometer 40 QP 1.5 S025 = Sonometer 40 QP 2.5 S035 = Sonometer 40 QP 2.5
	length of the insert mounted instead of energy meter	I110 = insert 110 mm/G 3/4" I190 = insert 190 mm/G 1" I260 = insert 190 mm/G 1 1/4"
AT / P330	station market code	AT = for all markets but without a P330 key for the ECL310 controller P330 = for all markets and the P330 key for the ECL310 controller is included

Example:

DSA 1 MINI Micro Grid DLO015LS015DE

Station type: DASA 1 MINI Micro Grid with ECL 310 controller, primary side connection on the left, secondary side connection on the top, nominal capacity 15 kW, low parameter station type L, comprising an energy meter Sonometer 40 QP 1.5, station version 1 - DE

The DSA 1 MINI station may be delivered in different configurations. These can be defined using the online tool: heatselector.danfoss.com



Technical data

Station version 1- DE

Type	QP	PN	Insert instead of energy meter	Energy meter SONOMETER 40	Control valve		Actuator type	number of plates in HEX	Primary side			Secondary side			Safety valve opening pressure	Safety thermostat
	kW				type	KVS			DN	VP max.	dp max.	DN	VP max.	dp max.		
															m3/h	AMV
L	15*	16	G3/4"×110	QP 1,5	AVQM	1,6	10	-16	G1"	0,40	49	Rp 1"	0,90	19	3,0 / TÜV	-
	30*	16	G3/4"×110	QP 1,5	AVQM	1,6	10	-26	G1"	0,63	48	Rp 1"	1,41	18	3,0 / TÜV	-
	40*	16	G3/4"×110	QP 1,5	AVQM	2,5	10	-36	G1"	0,98	49	Rp 1"	2,14	21	3,0 / TÜV	-
	60*	16	G1"×190	QP 2,5	AVQM	4	10	-50	G1"	1,57	50	Rp 1¼"	2,96	21	3,0 / TÜV	-
	75*	16	G1"×190	QP 2,5	AVQM	6,3	20	-60	G1"	2,46	53	Rp 1¼"	3,54	21	3,0 / TÜV	-
E	15*	25	G3/4"×110	QP 1,5	AVQM	1,6	13	-16	G1"	0,40	49	Rp 1"	0,90	19	3,0 / TÜV	AT20/70..130°C
	30*	25	G3/4"×110	QP 1,5	AVQM	1,6	13	-26	G1"	0,63	48	Rp 1"	1,41	18	3,0 / TÜV	AT20/70..130°C
	40*	25	G3/4"×110	QP 1,5	AVQM	2,5	13	-36	G1"	0,98	49	Rp 1"	2,14	21	3,0 / TÜV	AT20/70..130°C
	60*	25	G1"×190	QP 2,5	AVQM	4	13	-50	G1"	1,57	50	Rp 1¼"	2,96	21	3,0 / TÜV	AT20/70..130°C
	75*	25	G1"×190	QP 2,5	AVQM	6,3	23	-60	G1"	2,46	53	Rp 1¼"	3,54	21	3,0 / TÜV	AT20/70..130°C

* Nominal capacity.

For other capacities the table: "Version 1 capacity in reference to the supply and return temperatures" should be consulted.

dp max – maximum pressure loss on the primary side or on the secondary side (for the pump selection)

VP max – maximum flow on the primary or secondary sides

Station version 1 – DE - capacity in reference to the supply and return temperatures

TVP	TRP	TRS	TVS	Nominal capacity [kW]				
				15*	30*	40*	60*	75*
[°C]				QP max [kW]				
100	55	52	72	20	33	50	69	82
100	50	48	70	23	36	55	76	90
95	60	55	75	16	25	40	63	82
95	55	52	75	18	29	45	72	94
95	55	52	72	18	29	45	68	82
95	50	48	75	17	30	44	63	77
95	45	42	72	23	36	57	90	113
95	42	40	70	17	32	46	66	80
90	60	57	80	14	22	34	54	66
90	60	55	80	14	22	34	54	86
90	60	50	80	14	22	34	54	86
90	60	58	75	14	22	34	54	70
90	60	55	75	14	22	34	54	82
90	60	50	75	14	22	34	54	86
90	60	50	70	14	22	34	54	82

TVP	TRP	TRS	TVS	Nominal capacity [kW]				
				15*	30*	40*	60*	75*
[°C]				QP max [kW]				
90	57	55	75	15	24	37	60	82
90	55	52	75	16	25	40	63	94
90	55	52	72	16	25	40	63	82
90	50	47	75	16	29	43	60	74
90	50	47	70	18	29	45	72	94
90	50	47	65	18	29	45	62	73
90	42	40	65	22	35	54	83	101
85	62	60	75	10	17	26	42	62
85	57	55	75	10	19	28	39	48
85	57	55	70	13	20	32	51	60
85	55	52	72	14	22	34	54	82
85	53	50	75	11	21	30	42	53
85	47	45	65	17	27	43	67	81
80	55	52	72	11	18	28	45	57
75	43	40	65	9	17	25	36	43

TVP – supply temperature on the primary side
TVS – supply temperature on the secondary side

TRP – return temperature on the primary side
TRS – return temperature on the secondary side



Technical data

Station version 2 – AT & P330

Type	QP kW	PN	Insert instead of energy meter	Energy meter SONOMETER 40	Control valve		Actuator type	number of plates in HEX	Primary side			Secondary side			Safety valve opening pressure	Safety thermostat
					type	KVS			DN	VP max.	dp max.	DN	VP max.	dp max.		
	m3 / h	AMV	XB12H-1	m3 / h			kPa	m3 / h							kPa	bar (g)
L	40*	16	G3/4"×110	QP 1,5	AVQM	2,5	10	-36	G1"	0,98	49	Rp 1"	2,14	21	3,0 / TÜV	-
	60*	16	G1"×190	QP 2,5	AVQM	4	10	-50	G1"	1,57	50	Rp 1 1/4"	2,96	21	3,0 / TÜV	-
	75*	16	G1"×190	QP 2,5	AVQM	6,3	20	-60	G1"	2,46	53	Rp 1 1/4"	3,54	21	3,0 / TÜV	-
	90*	16	G1 1/4"×260	QP 3,5	AVQM	8	20	-80	G1"	3,00	51	Rp 1 1/2"	4,31	25	3,0 / TÜV	-
	105*	16	G1 1/4"×260	QP 3,5	AVQM	8	20	-100	G1"	3,50	60	Rp 1 1/2"	5,05	30	3,0 / TÜV	-

*Nominal capacity.

For other capacities the table: "Version 2 – AT & P330 capacity in reference to the supply and return temperatures" should be consulted.

dp max – maximum pressure loss on the primary side or on the secondary side (for the pump selection)

VP max – maximum flow on the primary or secondary sides

Station version 2 – AT & P330 - capacity in reference to the supply and return temperatures

TVP	TRP	TRS	TVS	Nominal capacity [kW]							
				15*	30*	40*	60*	75*	90*	105*	
[°C]				QP max [kW]							
100	55	52	72	20	33	50	69	82	98	114	
100	50	48	70	23	36	55	76	90	108	126	
95	60	55	75	16	25	40	63	82	98	114	
95	55	52	75	18	29	45	72	94	113	132	
95	55	52	72	18	29	45	68	82	98	114	
95	50	48	75	17	30	44	63	77	92	107	
95	45	42	72	23	36	57	90	113	136	159	
95	42	40	70	17	32	46	66	80	96	112	
90	60	57	80	14	22	34	54	66	79	92	
90	60	55	80	14	22	34	54	86	103	120	
90	60	50	80	14	22	34	54	86	103	120	
90	60	58	75	14	22	34	54	70	84	98	
90	60	55	75	14	22	34	54	82	98	114	
90	60	50	75	14	22	34	54	86	103	120	
90	60	50	70	14	22	34	54	82	98	114	

TVP	TRP	TRS	TVS	Nominal capacity [kW]							
				15*	30*	40*	60*	75*	90*	105*	
[°C]				QP max [kW]							
90	57	55	75	15	24	37	60	82	98	114	
90	55	52	75	16	25	40	63	94	113	132	
90	55	52	72	16	25	40	63	82	98	114	
90	50	47	75	16	29	43	60	74	89	104	
90	50	47	70	18	29	45	72	94	113	132	
90	50	47	65	18	29	45	62	73	88	103	
90	42	40	65	22	35	54	83	101	121	141	
85	62	60	75	10	17	26	42	62	74	86	
85	57	55	75	10	19	28	39	48	58	68	
85	57	55	70	13	20	32	51	60	72	84	
85	55	52	72	14	22	34	54	82	99	116	
85	53	50	75	11	21	30	42	53	64	75	
85	47	45	65	17	27	43	67	81	97	113	
80	55	52	72	11	18	28	45	57	69	81	
75	43	40	65	9	17	25	36	43	52	61	

TVP – supply temperature on the primary side

TRP – return temperature on the primary side

TVS – supply temperature on the secondary side

TRS – return temperature on the secondary side

Station version 2 - AT & P330

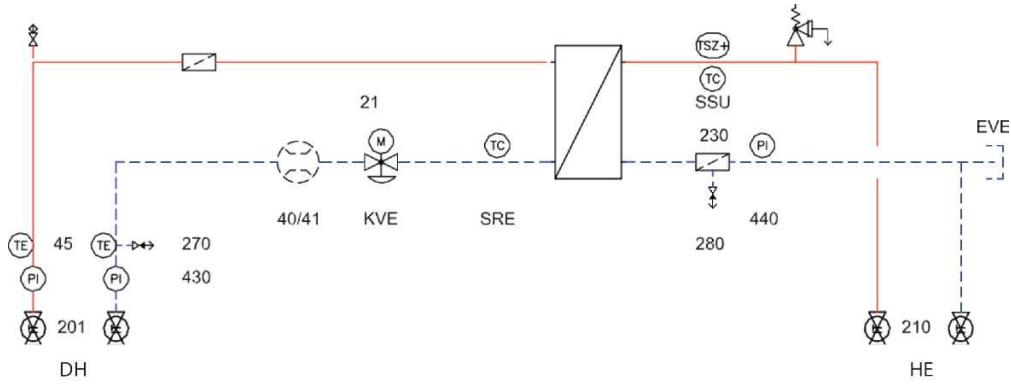

Primary and secondary side connections from the bottom

- 4 Heating, supply
- 5 Heating, return
- 8 District heating, supply
- 9 District heating, return

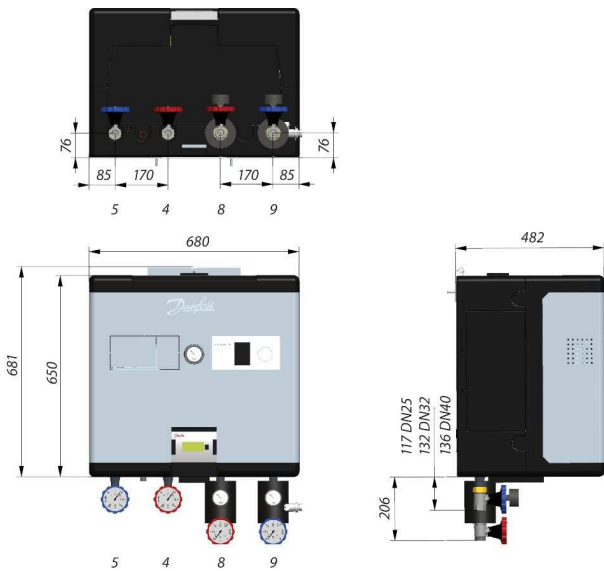

Station version 2 - AT & P330 nominal capacity QP [kW]	Weight approx. [kg]
	type L
40*	49
60*	51
75*	53
90*	55
105*	57

*Nominal capacity

For other capacities the table:

"Station version 2 – AT & P330 - capacity in reference to the supply and return temperatures" should be consulted.

Legend / Components

HEX	Microplate heat exchanger (MPHE), brazed, type: XB12
21	Actuator, 3-point, without safety function, type AMV 10/20 (for stations type L only)
22	Actuator, 3-point, with safety function, type AMV 13/23 (for stations type E only)
KVE	PICV - pressure independent control valve, PN16/max. 130°C, type AVQM (for stations type L only)
KVE	PICV - pressure independent control valve, PN25/max. 150°C, type AVQM (for stations type E only)
40	Insert (a piece of pipe) instead of an energy meter
41	Energy meter, PN25/max. 130°C, M-BUS, 230V~, type SONOMETER 40
45	Temperature sensor fitting for a heat meter - a pocket or an adapter for a directly mounted temperature sensor
201	Ball valve, PN25/max. 150°C, G 1", ext. ISO 228/1 with an integrated bimetal thermometer, size DA=80, class 1.0, temperature range: 0°C to 120°C
220	Strainer, PN25/max. 150°C, G1" or G 1 1/4" ext. ISO 228/1
270	High-pressure drain, PN25/max. 150°C, G3/4" with hose connection, and cap with chain
275	High pressure air vent, PN25/max. 150°C, G1/4"
430	Manometer, size DA = 50 mm, 0-16 bar, class 1.6, G 1/4" (for stations type L - station version 2 only)
432	Manometer, size DA = 80 mm, 0-16 bar, class 1.0, G 1/2" (for stations type L only)
433	Manometer, size DA = 80 mm, 0-25 bar, class 1.0, G 1/2" (for stations type E only)
SRE	Return temperature limiter sensor PT1000
SVF	Safety valve, opening pressure: 3.0 bar, TÜV
HPU	Insert (a piece of pipe) instead of a heating pump, G 1 1/2" × 180mm
210	Ball valve, PN16/max. 120°C, G1" – G1 1/2" int. ISO 228/1, with an integrated bimetal thermometer, size DA=80, class 1.0, temperature range: 0°C to 120°C
230	Strainer, PN16/max. 120°C, Rp 1 1/4"
280	Drain, PN16/max. 120°C, G3/4" with hose connection, and cap on chain
EVE	Expansion vessel connection, Rp 3/4" with plug
440	Manometer, size DA = 50 mm, 0 – 4 bar, class 2.5, capillary type
ECS	Electronic controller in a control box, ECL310
SSU	Secondary side supply temperature sensor, PT1000
560	Safety thermostat, STW - safety temperature monitor (for stations type E only)
DH	District heating
HE	Heating secondary side (for different types of systems)

Materials

Pipes and fittings, flanges, moulded parts, unions	P235GH EN 10216-2, CW602N (CuZn36Pb2As), CW 617 N (CuZn40Pb2), EN 12165
Heat exchanger	1.4404 mit CU-Lot
Fittings and valves	CC499K (CuSn5Zn5Pb2-C) EN 1982, CW602N (CuZn36Pb2As) EN 12165
Insulation	37 ± 1/0 mm EPP Hartschaum ($\lambda = 0,035$ W/mK) nach EN 12667; entspricht 100% ENEC

Accessories

The accessories:

- 168F0000 (position S4 in the drawing)
- 168F0001 (positions S6 and S8 in the drawing)

are used in domestic hot water stations (DHW) or in buffer tanks (BU) that can be connected to DSA 1 MINI Micro Grid.

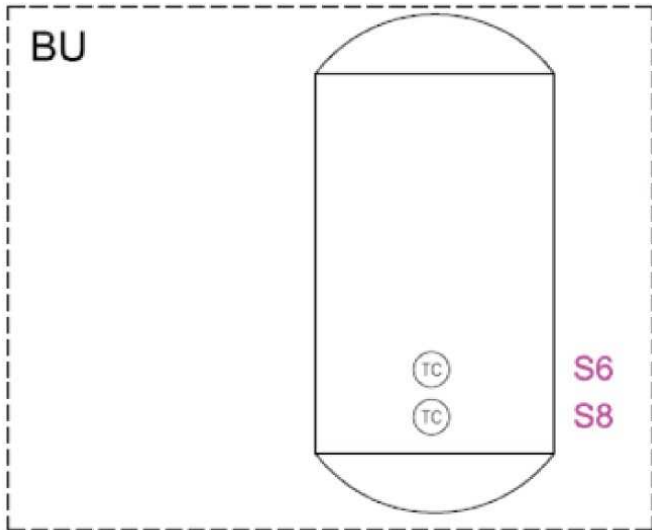

Accessories - temperature sensors S6 and S8 mounted in a buffer tank (BU).

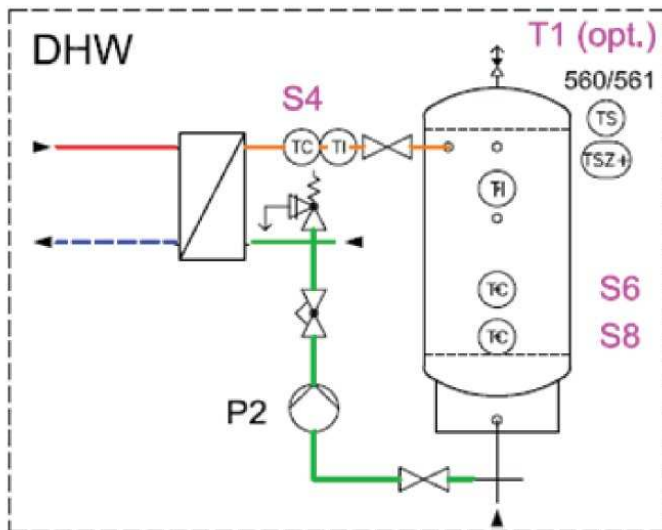

Accessories - temperature sensors S6 and S8 mounted in a domestic hot water tank (DHW) and S4 in the supply line for the charging process control. The safety thermostat T1 is an additional option.

Accessories for version 1 – DE and version 2 – AT & P330

Code	Description	Marking in the drawing
168F0000	Push-in temperature sensor with connecting cable, PT1000, length 50 mm, max temperature 180°C Pocket for temperature sensor, length 100mm, connection G1/2", stainless steel Cable gland, strain relief, M 12 × 1,5 mm	S6 or S8
168F0001	Push-in temperature sensor with connecting cable, PT1000, length 50 mm, max temperature 180°C Pocket for temperature sensor, length 200mm, connection G1/2", stainless steel Cable gland, strain relief, M 12 × 1,5 mm	S4
168F0002	Thermostat type STW AT 20: safety temperature monitor range (STW): 40°C to 100°C, sensor connection: G1/2"	T1
168F0003	Double pocket for temperature sensor, length 200mm	T1
168F0004	Temperature controller type TR and safety thermostat type STW AT 120: • TR temperature range: 0–120°C, • STW safety temperature monitor range: 70–130°C, Sensor connection G1/2"	T1
168F0005	Adapter for a direct temperature sensor L=27,5mm, connection: M10 × 1,0mm / G1/2", stainless steel	–
168F0006	Adapter for a direct temperature sensor L=38,0mm, connection: M10 × 1,0mm / G1/2", stainless steel	–
087H3821	A337 - application key for ECL310*	–
087H3822	A347 - application key for ECL310*	–
087H3825	A367 - application key for ECL310*	–
087H3827	A377 - application key for ECL310*	–
087H3832	A390 - application key for ECL310*	–
168F0007	Insulation shell for a ball valve DN25–32, max temperature 135°C	–
168F0008	Insulation shell for a ball valve DN40–50, max temperature 135°C	–

*Other application keys are available on request

Certificates, declarations and approvals

The list contains all certificates, declarations, and approvals for this product type. Individual code number may have some or all of these approvals, and certain local approvals may not appear on the list.

When you click on the link you will be directed to the latest version of the 'Declaration of Conformity'. Products developed and sold before this date of issue conform to the directives/standards in force at the time of their sale.

Approval type	Title	Certification body	Approval topic
Declaration of Incorporation	Danfoss DOI PL32DOI000001en-000001.01	Danfoss	MD
Export Control Declaration	Sub stations and DHW systems	Danfoss	

Contact details

Online support

Danfoss offers a wide range of support along with our products, including digital information, software, mobile apps and expert guidance. See the possibilities below.



The Danfoss Design center

Discover the Design Center, our advanced digital platform that streamlines product selection. With integrated tools and enhanced type pages, it's simpler than ever to access product information and documentation, and to select the right products. Check the availability of Danfoss products at partner locations and enjoy seamless transitions from selection to purchase with our basket-to-basket functionality. Whether you're buying from our distributors or directly from the Product Store, the Design Center simplifies your experience. Learn more at: designcenter.danfoss.com.



The Danfoss product store

The Danfoss Product Store is a one-stop shop available 24/7 for our customers, no matter where you are in the world or what area of industry you work in. Browse our catalog, check product details and documentation, view your prices and product availability, and quickly finalize your purchase. Start browsing at: store.danfoss.com.



Danfoss Partner Portal/Product Data tool

Designed to support you with easy access to product data extracts, essential resources, tools, and information. The Partner Portal provides a centralized hub for product documentation, training materials, marketing assets, and technical support, ensuring you have everything you need to succeed and grow your business with Danfoss. The Partner Portal is available 24/7 at: partner.danfoss.com and is ready to support your business.



Find technical documentation

Find technical documentation you need to get your project up running. Get direct access to our official collection of data sheets, certificates and declarations, manuals and guides, 3D models and drawings, case stories, brochures, and much more. Start searching now at: documentation.danfoss.com.



Danfoss Learning

Danfoss Learning is a free online learning platform. It features courses and materials specifically designed to help engineers, installers, service technicians, and wholesalers better understand the products, applications industry topics, and trends that will help you do your job better. Find your local Danfoss website here: learning.danfoss.com.



Get local information and support

Local Danfoss websites are the main sources for help and information about our company and products. Find product availability, get the latest regional news, or connect with a nearby expert - all in your own language. Find your local Danfoss website here: danfoss.com.

Danfoss A/S

Climate Solutions . danfoss.com . +45 7488 2222

Any information, including, but not limited to information on selection of product, its application or use, product design, weight, dimensions, capacity or any other technical data in product manuals, catalogues description, advertisements, etc. and whether made available in writing, orally, electronically, online or via download, shall be considered informative, and is only binding if and to the extent, explicit reference is made in a quotation or order confirmation. Danfoss cannot accept any responsibility for possible errors in catalogues, brochures, videos and other material. Danfoss reserves the right to alter its products without notice. This also applies to products ordered but not delivered provided that such alterations can be made without changes to form, fit or function of the products. All trademarks in this material are property of Danfoss A/S or Danfoss group companies. Danfoss and the Danfoss logo are trademarks of Danfoss A/S. All rights reserved.
