

Data sheet

Dynamic Valve™ Type RA-DV Pressure Independent Radiator Valve

Application

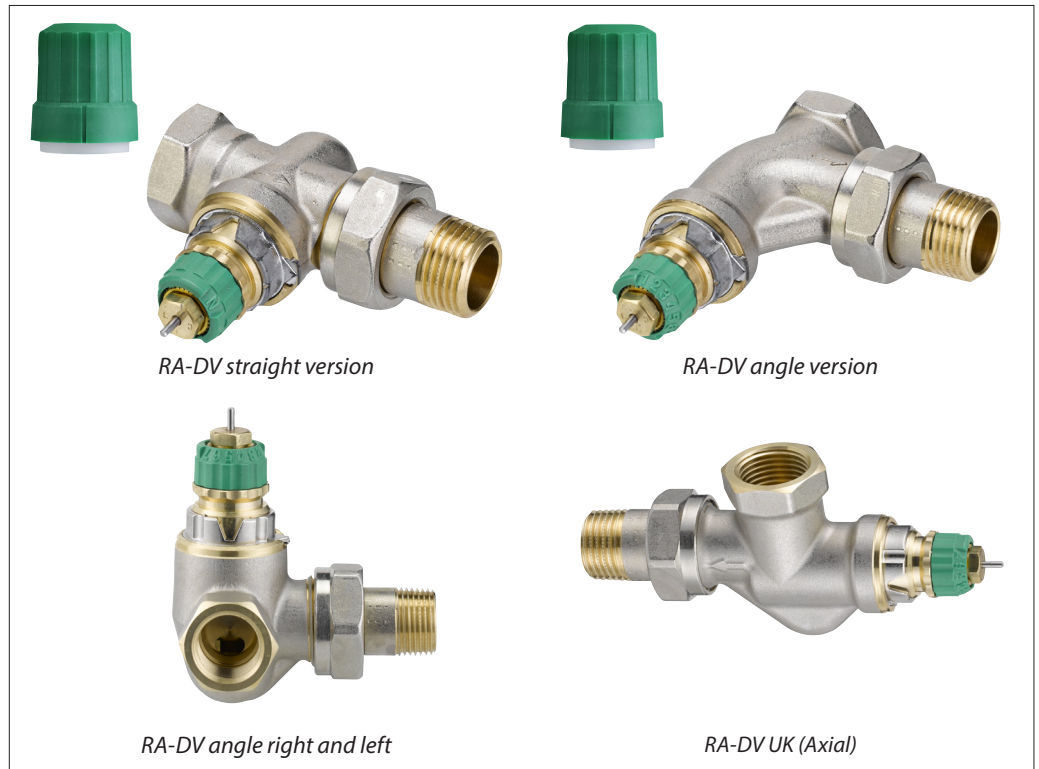

RA-DV is a series of pressure independent radiator valves, designed for use in 2-pipe heating systems together with all types of thermostatic sensors with Danfoss RA coupling.

RA-DV dynamic valves are fitted with a flow limiting device for presetting of the maximum water flow. The valves are available with maximum water flow of 10 - 135 l/h.

RA-DV has a built-in pressure regulator, which keeps the differential pressure at a constant level of 0.1 bar, thus maintaining the set flow.

RA-DV is supplied with a protective cap, which can be used for manual regulation during the construction phase.

The protective cap must not be used as manual shut off device. A special manual shut off device (code no. 013G5002) should be used.

To be able to distinguish between other valve bodies of the Danfoss RA series the RA-DV protective cap and presetting ring are green.

RA-DV valve bodies are manufactured from brass with a nickel plating.

The gland seal pressure pin is chromium steel and works in a lifetime lubricated O-ring. The complete gland seal assembly can be replaced without draining down the system.

Should water treatment be used it is essential that the manufacturer's dosing instructions are strictly observed. Formulations containing mineral oil should be avoided.

The water quality in the system must comply with VDI 2035, TÜV 1466, AGFW Work Part FW 510, or Vejledning Vandbehandling og korrosionsforbyggelse (Sep 2018), to ensure corrosion protection and optimal valve performance.

Quality



RA-DV Dynamic Valves™ with sensors React, RAE and RAS-C are certified according to the European standard EN 215.

All Danfoss radiator thermostats are manufactured in factories, assessed and certified by BVC (Bureau Veritas Certification) against ISO 9001 and ISO 14001.

Principles

Application example 1

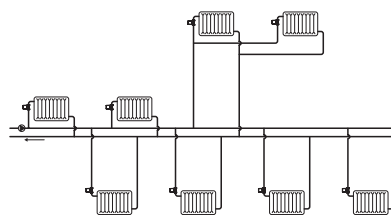

Application example 2

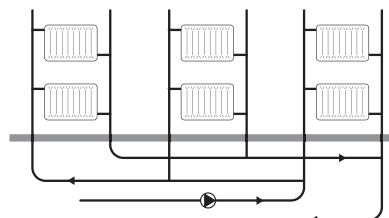

Ordering

Valve Type	Size	Connection		Design	Code no.
		Inlet	Outlet		
RA-DV	DN10	Rp 3/8	R 3/8	Angle	013G7721
RA-DV	DN10	Rp 3/8	R 3/8	Straight	013G7722
RA-DV	DN10	Rp 3/8	R 3/8	Angle	013G7711
RA-DV	DN10	Rp 3/8	R 3/8	Straight	013G7712
RA-DV	DN10	Rp 3/8	R 3/8	UK (Axial)	013G7709
RA-DV	DN10	Rp 3/8	R 3/8	Angle Right	013G7717
RA-DV	DN10	Rp 3/8	R 3/8	Angle Left	013G7718
RA-DV	DN15	Rp 1/2	R 1/2	Angle	013G7723
RA-DV	DN15	Rp 1/2	R 1/2	Straight	013G7724
RA-DV	DN15	Rp 1/2	R 1/2	Angle	013G7713
RA-DV	DN15	Rp 1/2	R 1/2	Straight	013G7714
RA-DV	DN15	Rp 1/2	R 1/2	UK (Axial)	013G7710
RA-DV	DN15	Rp 1/2	R 1/2	Angle Right	013G7719
RA-DV	DN15	Rp 1/2	R 1/2	Angle Left	013G7720
RA-DV	DN20	Rp 3/4	R 3/4	Angle	013G7725
RA-DV	DN20	Rp 3/4	R 3/4	Straight	013G7726
RA-DV	DN20	Rp 3/4	R 3/4	Angle	013G7715
RA-DV	DN20	Rp 3/4	R 3/4	Straight	013G7716

Accessories	Code no.
Gland seal, 10 pcs.	013G0290
Δp tool for pump optimization	013G7861
Valve insert with Regulator 5 pieces	013G7831
PFM100 measuring instrument	003L8260

Compression fittings*	Tube dimension	For valve type	Code no.
For PEX plastic tubing, 10 pcs.	12 x 1.1 mm	RA-DV 15	013G4143
	14 x 2 mm	RA-DV 15	013G4144
	15 x 2.5 mm	RA-DV 15	013G4147
For Alupex tubing, 10 pcs.	14 x 2 mm	RA-DV 15	013G4174
	16 x 2 mm	RA-DV 15	013G4176
For steel and copper tubing, 10 pcs.	10 mm	RA-DV 10	013G4100
	12 mm	RA-DV 10	013G4102
	10 mm	RA-DV 15	013G4110
	12 mm	RA-DV 15	013G4112
	14 mm	RA-DV 15	013G4114
	15 mm	RA-DV 15	013G4115
	16 mm	RA-DV 15	013G4116

* For more information on Danfoss compression fittings, please refer to the compression fittings data sheet.

Technical Data

Max. working pressure ¹⁾	10 bar							
Max. differential pressure	0.6 bar							
Min. differential pressure	0.1 bar							
Test pressure	16 bar							
Max. working temperature	95° C							
Min. working temperature	2° C							
Presetting	1	2	3	4	5	6	7	N
Max ³⁾	10 l/h	15 l/h	20 l/h	35 l/h	50 l/h	80 l/h	100 l/h	135 l/h
with Danfoss Aveo® / Areo® sensor ²⁾	9 l/h	14 l/h	18 l/h	30 l/h	45 l/h	70 l/h	90 l/h	130 l/h
with React, Redia, Regus ²⁾	8 l/h	12 l/h	16 l/h	25 l/h	40 l/h	65 l/h	85 l/h	110 l/h

¹⁾ Working pressure = static + differential pressure. The maximum differential pressure specified is the maximum pressure at which the valves give satisfactory regulation.

²⁾ At setting N the value is stated according to EN 215, at XP = 2K i.e. the valve is closed at 2° C higher room temperature. At lower settings the XP value is reduced to 0.5K of the setting value 1. All values are max. flow at 0.1 bar.

³⁾ The value states the max. flow at maximum lift, i.e. at fully open valve at 0.1 bar.

Presetting

The presetting values of RA-DV valves can be adjusted easily and accurately without the use of tools (default setting = N).

Presetting can be selected in steps from 1 to 7:

- Remove protective cap / thermostatic sensor.
- Find reference mark - ◀
- Turn setting ring until the aquired presetting aligns with the reference mark.

At setting N the valve is fully open. This setting can be used as a flushing position, if the system has to be flushed out because of dirt problems.

When the thermostatic sensor has been installed, the presetting is protected against unintended regulation.

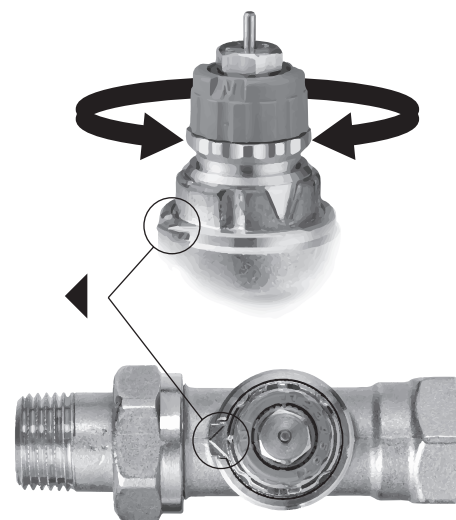

Design

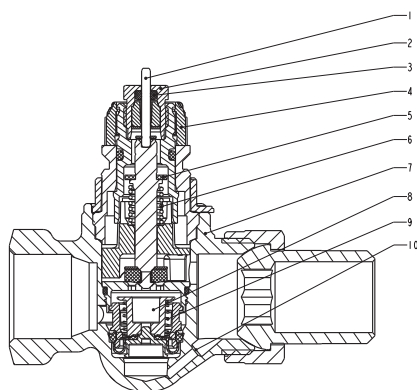

1. Pressure pin
2. Gland seal
3. O-ring
4. Setting dial
5. Seal
6. Regulation spring
7. Valve body
8. Regulator
9. Spring
10. Impulse connection

The thermostatic radiator valve consist of a sensor and the valve body RA-DV. Sensor and valve body are ordered separately.

The gland seal of the valve can be changed in operation, i.e. with water and pressure on the system. Counter hold with star spanner number 17 and loosen the gland seal with spanner number 10.

Materials in contact with water

Valve body and other metal parts	Brass
Valve body surface	Nickle plated
Flow-limiter	PPS
O-ring	EPDM
Valve cone	NBR
Pressure pin and spring	Chrome steel
Regulator	Brass/PPS/EPDM

Capacities

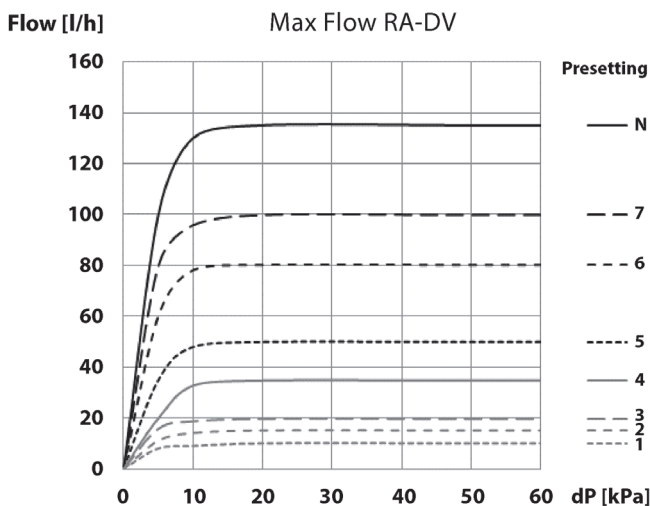

Sizing example

Required heat	700 W
Cooling across radiator	20 °C
Flow through radiator	$Q = \frac{700}{20 \times 1.16} = 30 \text{ l/h}$
Min. pressure for constant flow	0.1 bar
Valve setting*	4

*Alternatively the setting can be read directly in the table "Technical Data".

Dimensions

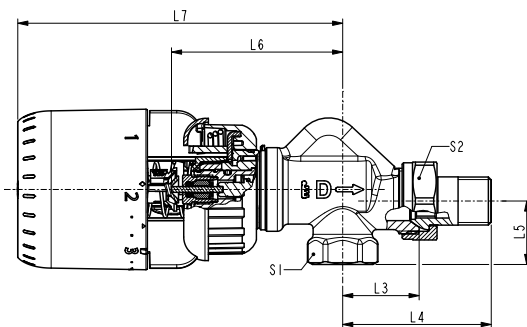

RA-DV UK (Reverse Angle Run) / Danfoss Aero and Aveo® sensor

Type	Code no.	ISO 7-1			L ₁	L ₂	L ₃	L ₄	L ₅	L ₆	L ₇	Arc. flats	
		DN	D	d ₂								S ₁	S ₂
RA-DV 10 UK	013G7709	10	R _p 3/8	R 3/8	-	-	26	51	22	61	114	22	27
RA-DV 15 UK	013G7710	15	R _p 1/2	R 1/2	-	-	29	58	27	61	114	27	30

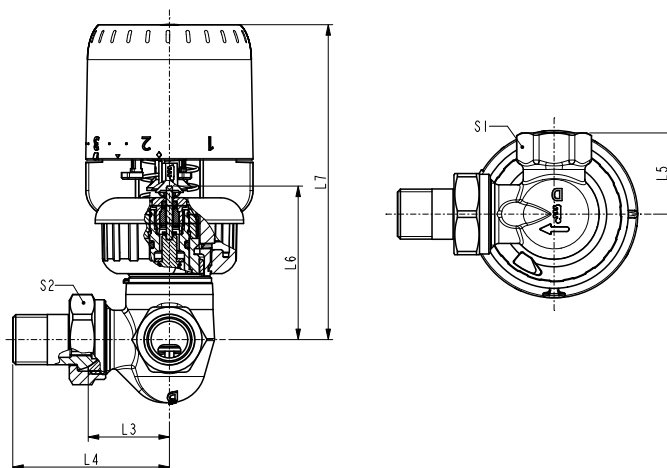

RA-DV DN : Bypass left & right / Danfoss Aero and Aveo® sensor

Type	Code no.	ISO 7-1			L ₁	L ₂	L ₃	L ₄	L ₅	L ₆	L ₇	Arc. flats	
		DN	D	d ₂								S ₁	S ₂
RA-DV 10 right	013G7717	10	R _p 3/8	R 3/8	-	-	27	52	27	52	105	22	27
RA-DV 10 left	013G7718	10	R _p 3/8	R 3/8	-	-	27	52	27	52	105	22	27
RA-DV 15 right	013G7719	15	R _p 1/2	R 1/2	-	-	30	58	33	52	105	27	30
RA-DV 15 left	013G7720	15	R _p 1/2	R 1/2	-	-	30	58	33	52	105	27	30

Dimensions (continuous)

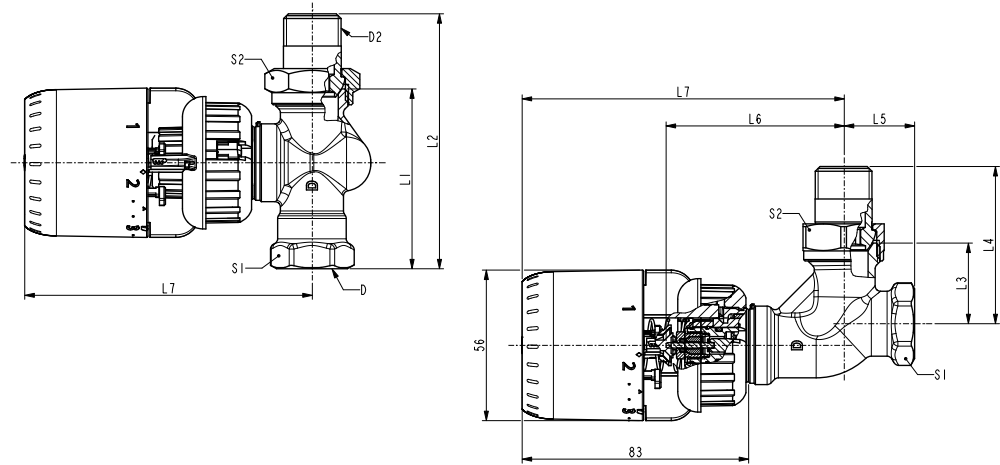

Type	Code no.	ISO 7-1			L ₁	L ₂	L ₃	L ₄	L ₅	L ₆	L ₇	Arc. flats	
		DN	D	d ₂								S ₁	S ₂
RA-DV 10 angle	013G7711	10	R _p 3/8	R 3/8	-	-	24	49	20	64	116	22	27
RA-DV 10 straight	013G7712	10	R _p 3/8	R 3/8	50	75	-	-	-	-	104	22	27
RA-DV 15 angle	013G7713	15	R _p 1/2	R 1/2	-	-	26	53	23	66	119	27	30
RA-DV 15 straight	013G7714	15	R _p 1/2	R 1/2	55	82	-	-	-	-	104	27	30
RA-DV 10 angle	013G7721	10	R _p 3/8	R 3/8	-	-	26	51	22	64	116	22	27
RA-DV 10 straight	013G7722	10	R _p 3/8	R 3/8	58	84	-	-	-	-	104	22	27
RA-DV 15 angle	013G7723	15	R _p 1/2	R 1/2	-	-	29	57	26	66	119	27	30
RA-DV 15 straight	013G7724	15	R _p 1/2	R 1/2	65	94	-	-	-	-	104	27	30
RA-DV 20 angle	013G7715	20	R _p 3/4	R 3/4	-	-	30	63	26	66	119	32	37
RA-DV 20 straight	013G7716	20	R _p 3/4	R 3/4	65	97	-	-	-	-	105	32	37
RA-DV 20 angle	013G7725	20	R _p 3/4	R 3/4	-	-	34	67	29	66	119	32	37
RA-DV 20 straight	013G7726	20	R _p 3/4	R 3/4	74	107	-	-	-	-	105	32	37

Note! If React, Redia, Regus sensors are used instead of sensors Aveo or Aero the L₇ measurement is extended with 10 mm.

Danfoss A/S

Climate Solutions • danfoss.com • +45 7488 2222

Any information, including, but not limited to information on selection of product, its application or use, product design, weight, dimensions, capacity or any other technical data in product manuals, catalogues descriptions, advertisements, etc. and whether made available in writing, orally, electronically, online or via download, shall be considered informative, and is only binding if and to the extent, explicit reference is made in a quotation or order confirmation. Danfoss cannot accept any responsibility for possible errors in catalogues, brochures, videos and other material. Danfoss reserves the right to alter its products without notice. This also applies to products ordered but not delivered provided that such alterations can be made without changes to form, fit or function of the product.

All trademarks in this material are property of Danfoss A/S or Danfoss group companies. Danfoss and the Danfoss logo are trademarks of Danfoss A/S. All rights reserved.