



Hot water balancing

MTCV

Description

The MTCV is a multifunctional thermostatic balancing valve used in domestic hotwater installations with circulation.

The MTCV provides a thermal balance in hot water installations by keeping a constant temperature in the system, thus limiting the flow in the circulation pipes to the minimum required level.

To meet the increasing demands placed on the quality of drinking water, Danfoss MTCV valves are made from corrosion resistant and low lead materials:

- valve body made from rg5 bronze material;
- components made from low lead;
- main cone made from advanced engineering polymere POM-C.

Features & benefits

- An automatic (self-acting) disinfection module - thermo-element
- An electronic controller with thermal actuator TWA and temperature sensors PT1000

Ordering

Product code numbers

Description	Valve size	Code number
MTCV DN 15, A version, multifunctional thermostatic circulation valve	DN 15	003Z4515
MTCV DN 20, A version, multifunctional thermostatic circulation valve	DN 20	003Z4520
MTCV PURE A VERSION DN15	DN 15	003Z6515
MTCV PURE A VERSION DN20	DN 20	003Z6520

Accessories code numbers



003Z1024

Adapter for ESMB PT1000

Adapter for ESMB PT1000



087N0011

ESMC, Pt 1000



003Z1023

BI metal thermometer with adapter

BI metal thermometer with adapter



003Z1022

Adapter for thermo actuator (module C)

Adapter for thermo actuator (module C)



003Z2021

Thermostatic disinfection module for MTCV version B

Thermostatic disinfection module for MTCV version B



003Z1038

MTCV SHUT-OFF FITTINGS DN 20

MTCV SHUT-OFF FITTINGS DN 20



003Z1040

Fittings for soldering Cu 28 mm

Fittings for soldering Cu 28 mm



003Z1039

Fittings for soldering Cu 22 mm

Fittings for soldering Cu 22 mm



087B1184

ESMB-12, Pt 1000

ESMB-12, Pt 1000 Universal sensor



003Z1035

Fittings for soldering Cu 18 mm

Fittings for soldering Cu 18 mm



003Z1034

Fittings for soldering Cu 15 mm

Fittings for soldering Cu 15 mm



003Z1037

MTCV SHUT-OFF FITTINGS DN 15

MTCV SHUT-OFF FITTINGS DN 15

Functions

Main functions of the MTCV

- Thermostatic balancing of hot water systems within the temperature range of 35 - 60 °C - version A.
- Automatic (self-acting) thermal disinfection at temperatures above 68°C with safety protection of the installation to prevent the temperature rising above 75 °C (automatically shuts-off circulation flow) - version "B".
- Automatic disinfection process, electronically controlled, with the possibility of programming the disinfection temperature and duration - version "C".
- Automatic flushing of the system by temporarily lowering the temperature setting to fully open the MTCV valve for a maximum flow.
- Temperature measurement possibility.
- Preventing of unwanted tampering.
- Constant temperature measurement and monitoring - version "C".
- Shut-off function of the circulation riser by means of optional fittings with a built-in ball valve.
- Modular upgrading of the MTCV valve during operation, under pressurized conditions.
- Servicing - when necessary the calibrated thermo-element can be replaced.

Function



Fig. : MTCV basic version - A

The MTCV - is a thermostatic self-acting, proportional valve. A thermo-element is placed in the valve cone to react to temperature changes.

When increases the water temperature above the set point value, the thermo-element expands and the valve's cone moves towards the valve seat, thus limiting circulation flow.

When decreases the water temperature below the set point value, the thermo-element will open the valve and allow more flow in the circulation pipe. The valve is in equilibrium (nominal flow = calculated flow) when the water temperature has reached the value set on the valve.

When the water temperature is 5 °C higher than the set point value, the flow through the valve stops.

A special sealing of the thermo-element protects it against direct contact with water, which prolongs the durability of the thermo-element and at the same time secures a precise regulation.

A safety spring protects the thermo-element from being damaged when the water temperature exceeds the value on the set point.

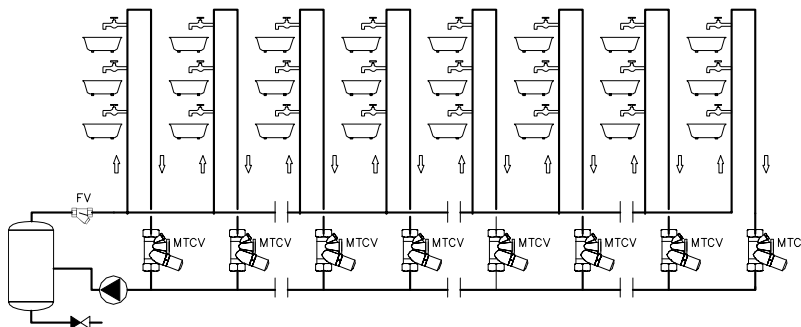

Fig. : Example of MTCV / basic version / placement in domestic hot water system



Fig. : MTCV self-acting version with automatic thermal disinfection function - B (* thermometer is accessory)

The MTCV standard version - A can easily and quickly be upgraded to the thermal disinfection function against the Legionella bacteria in hot water systems.

After removing the plug from the disinfection plug (this can be done during working conditions, under pressure) the thermostatic disinfection module can be mounted.

The disinfection module will control the flow according to its regulating characteristics, thus performing a thermal disinfection of the hot water installation.

The mounted disinfection module automatically opens a by-pass of $K_{v \min} = 0.15 \text{ m}^3/\text{h}$, which allows flow for the disinfection. In the A version of the MTCV this by-pass is always closed in order to avoid sedimentation of dirt and calcium. The MTCV can thus be upgraded with the disinfection module even after a long period of working in the A version without risking blocking the bypass.

The regulation module in basic version A works within the temperature range 35-60 °C. When the temperature of the hot water increases above 65°C the disinfection process starts - meaning the flow through the main seat of the MTCV valve stops and the bypass opens for the "disinfection flow". The regulating function is now performed by the disinfection module, which opens the bypass when the temperature is above 65 °C.

The disinfection process is performed until a temperature of 70 °C is reached. When the hot water temperature is increased further, the flow through the disinfection bypass is reduced (the process of thermal balancing of the installation during disinfection) and when reaching 75 °C the flow stops. This is to protect the hot water installation against corrosion and sedimentation of calcium as well as to lower the risk of scalding.

A thermometer can optionally be mounted in both version A and B in order to measure and control the temperature of the circulating hot water.

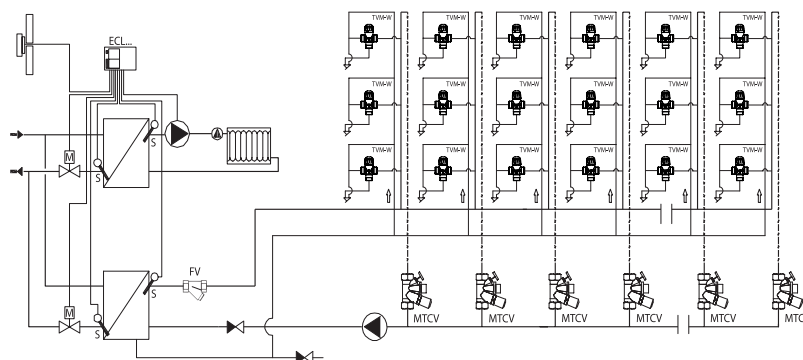

Fig. : Scheme of hot water installation with circulation - self acting version.



Fig. : Version with electronically controlled disinfection process - C

The MTCV version "A" and "B" can be upgraded to an electronic regulated disinfection process (version C). After removing the disinfection plug the adapter can be mounted and the thermo actuator TWA can be mounted.

A temperature sensor PT 1000 has to be mounted in the thermometer head.

Thermo-actuator and sensor are connected to the electronic regulator CCR2+ which allows an efficient and effective disinfection process in each circulation riser. The main regulation module works within the temperature range 35-60 °C. When the disinfection process/thermal- water treatment starts CCR2+ controls the flow through MTCV via thermo-actuators TWA.

Benefits of an electronic regulated disinfection process with CCR2+ are:

- Providing full control over the disinfection process in each individual riser.
- Optimisation of total disinfection time.
- Optional choice of temperature for the disinfection.
- Optional choice of time for the disinfection.
- On-line measurement and monitoring of the water temperature in each individual riser.
- Enabling the possibility of connecting to the controller in the heat substation or boiler room (i.e. Danfoss ECL) or to a BMS (Modbus).

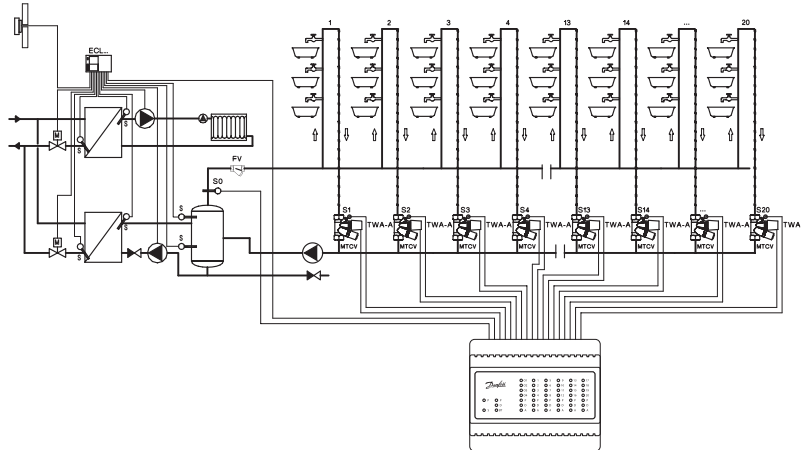

Fig. : Scheme of installation for disinfection and registration temperature

A) independent system (only sensor S0 needed)

B) dependent system (sensor S0 and connection to weather or another control needed)

Settings

Main function setting

1	Setting ring
2	Ring with a reference point
3	Plastic cover for unwanted tampering protection
4	Hole for screwdriver
5	Temperature setting screw (Allen-key 2.5 mm)
6	Reference for temperature setting point

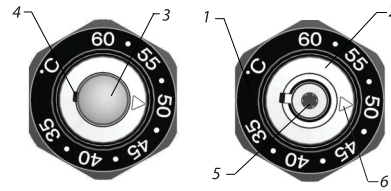

Fig. MTCV setting of the temperature

Temperature range: 35-60 °C MTCV's factory pre-setting 50 °C
The temperature setting can be made after removing the plastic cover (3), by lifting it with a screwdriver using the hole (4). The temperature setting screw (5) must be turned with an allen-key to match the wanted temperature on the scale with the reference point. The plastic cover (3) must be pressed back into place after the setting has been made.

It is recommended to control the set temperature with a thermometer. The temperature of the hot water from the last tapping point on the riser must be measured*. The difference between the measured temperature at the last tapping point and the temperature set on the MTCV is due to heat losses in the circulation pipe between the MTCV and the tapping point.

* where TVM valves (thermostatic mixing valves) are installed the temperature must be measured before the TVM valve.

Setting procedure

The required temperature setting of the MTCV depends on the required temperature at the last tap and the heat losses from the tap to MTCV in the same riser.

Example:

Required temperature at the last tap	48 °C
Heat losses from the last tap to the MTCV	3K

Required: correct setting of MTCV

Solution: correct setting of MTCV: $48 - 3 = 45$ °C

Note: After new setting use the thermometer to check if the required temperature at the tap is reached and correct the MTCV setting accordingly.

Product details

General data

Technical Data

Max. working pressure		10 bar
Test pressure		16 bar
Max. flow temperature		100 °C
k _V S at 20 °C	DN 20	1.8 m ³ /h
	DN 15	1.5 m ³ /h
Hysteresis		1.5 K

Design

1. Valve body
2. Spring
3. Cone
4. Thermo-element
5. O-ring
6. Safety spring
7. Setting ring
8. Setting knob
9. Plug for covering the setting
10. Cone for disinfection module
11. Safety spring
12. Plug for thermometer
13. Plug for disinfection module

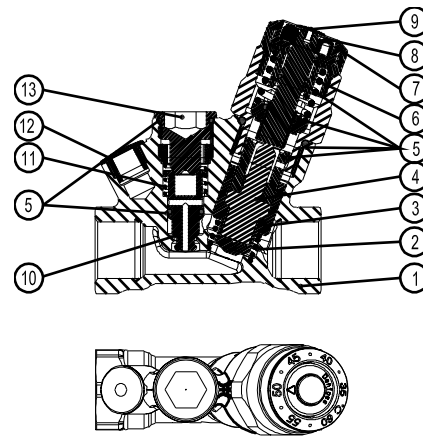

Fig.: Design - basic version - A

- 1-13. As described above
14. Bypass for disinfection
15. Thermometer
16. Gasket Cu
17. Disinfecting module

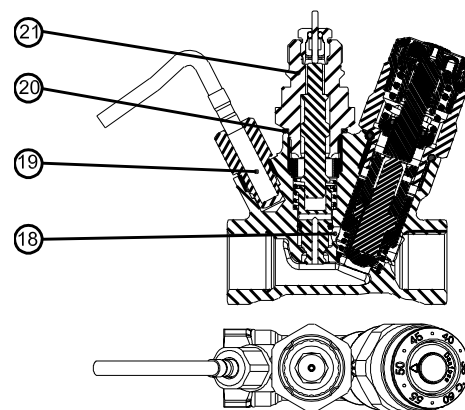

Fig.: Design - self-acting version with automatic thermal disinfection function - B

- 1-13. As described above
 18. Bypass; (position closed)
 19. Temperature sensor PT 1000
 20. Gasket Cu
 21. Adapter to connect thermoactuator TWA

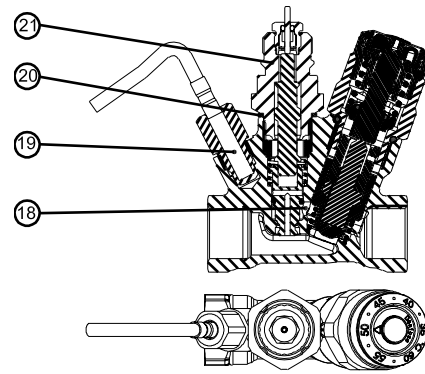

Fig. : Version with electronically controlled disinfection process - C

Materials

Valve body	Basic	Rg5
	PURE (< 0.1 % lead)	Rg+
Spring housing, etc.		Cuphin alloy (CW724R)
O-rings		EPDM
Spring, bypass cones		Stainless steel
Cone		POM-C (Acetal Homopolymer)

Capacity

Regulating characteristics

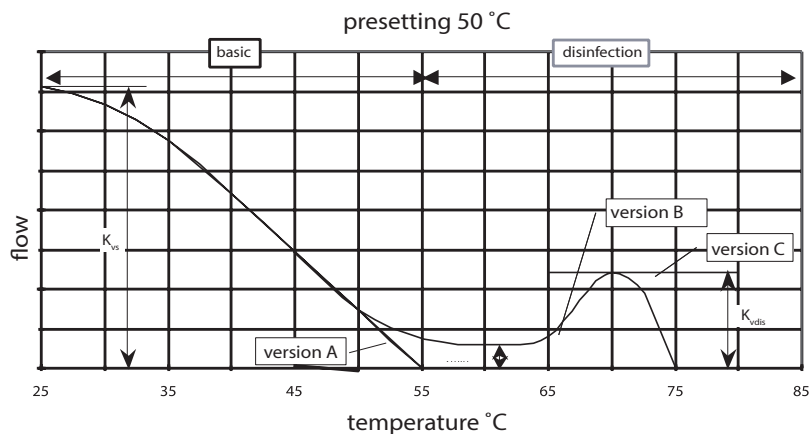

Fig. : The MTCV regulating characteristics

- Basic version A
- Version B:
 - $K_{v_{min}} = 0.15 \text{ m}^3/\text{h}$ - min. flow through the bypass when main regulation module is closed.
 - * $K_{v_{dis}} = 0.60 \text{ m}^3/\text{h}$ for DN 20,
 - * $K_{v_{dis}} = 0.50 \text{ m}^3/\text{h}$ for DN 15 - max. flow of the disinfection process by a temperature of 70 °C.
- Version C:
 - * $K_{v_{dis}} = 0.60 \text{ m}^3/\text{h}$ for DN 20 and DN 15 - flow through the MTCV when the disinfection module is fully opened (regulation at thermo-actuator TWA-NC).
 - * $K_{v_{dis}} - K_v$ during disinfection process

Pressure and temperature data

Pressure and flow chart

MTCV - DN 15

Differential pressure 1 bar, DN 15

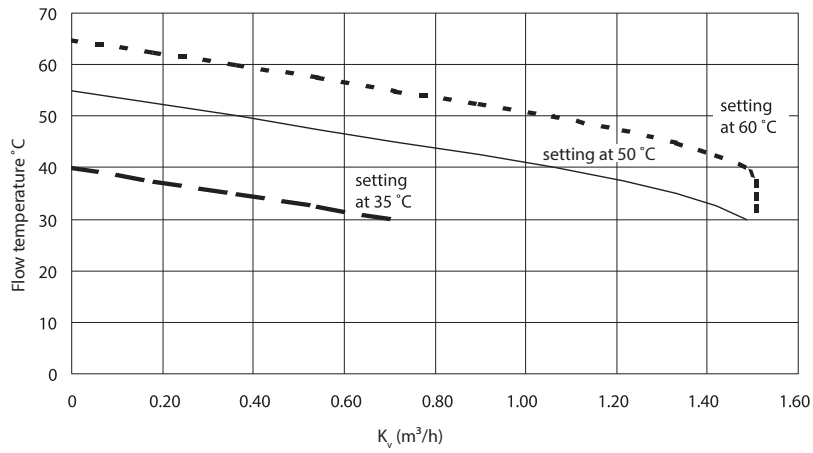

	Preset	Preset	Preset	Preset	Preset	Preset	k_v (m ³ /h)
	60°C	55°C	50°C	45°C	40°C	35°C	
Flow Temperature °C	65	60	55	50	45	40	0
	62.5	57.5	52.5	47.5	42.5	37.5	0.238
	60	55	50	45	40	35	0.427
	57.5	52.5	47.5	42.5	37.5	32.5	0.632
	55	50	45	40	35	30	0.795
	52.5	47.5	42.5	37.5	32.5		0.963
	50	45	40	35	30		1.087
	47.5	42.5	37.5	32.5			1.202
	45	40	35	30			1.283
	42.5	37.5	32.5				1.351
	40	35	30				1.394
	37.5	32.5					1.437
	35	30					1.469
	32.5						1.500
30						1.500	

Differential pressure 1 bar, DN 15 - disinfection process

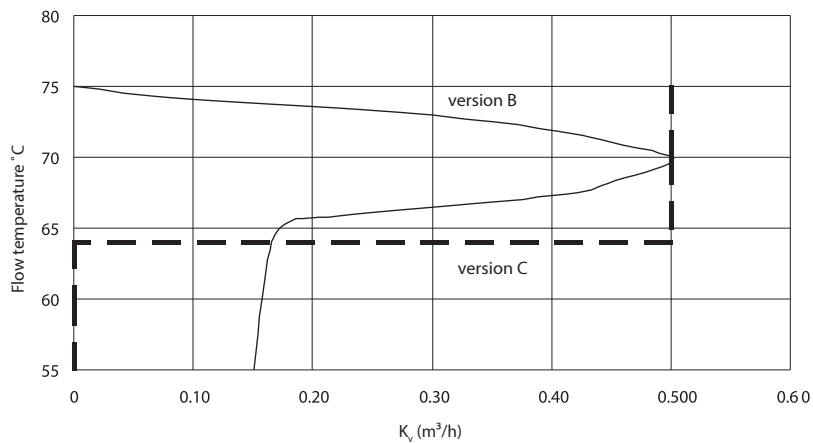

MTCV - DN 20

Differential pressure 1 bar, DN 20

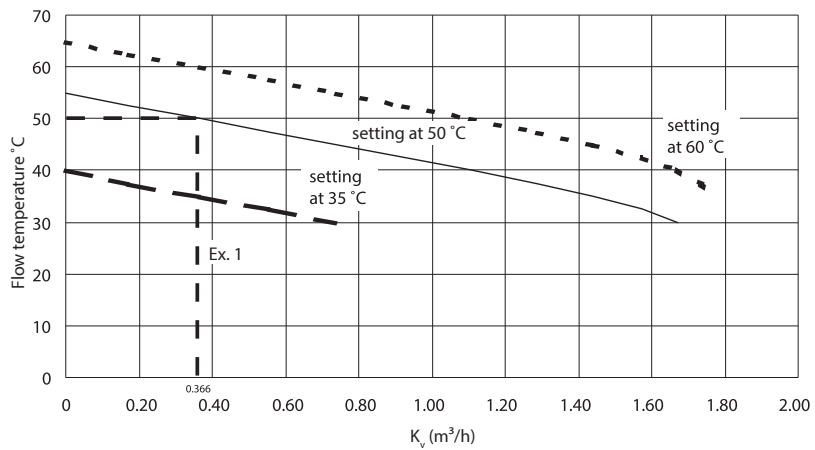

	Preset	Preset	Preset	Preset	Preset	Preset	k_v (m ³ /h)
	60°C	55°C	50°C	45°C	40°C	35°C	
Flow Temperature °C	65	60	55	50	45	40	0
	62.5	57.5	52.5	47.5	42.5	37.5	0.251
	60	55	50	45	40	35	0.442
	57.5	52.5	47.5	42.5	37.5	32.5	0.645
	55	50	45	40	35	30	0.828
	52.5	47.5	42.5	37.5	32.5		1.000
	50	45	40	35	30		1.164
	47.5	42.5	37.5	32.5			1.322
	45	40	35	30			1.462
	42.5	37.5	32.5				1.577
	40	35	30				1.667
	37.5	32.5					1.733
	35	30					1.753
	32.5						1.761
	30						1.761

Differential pressure 1 bar, DN 20 - disinfection process

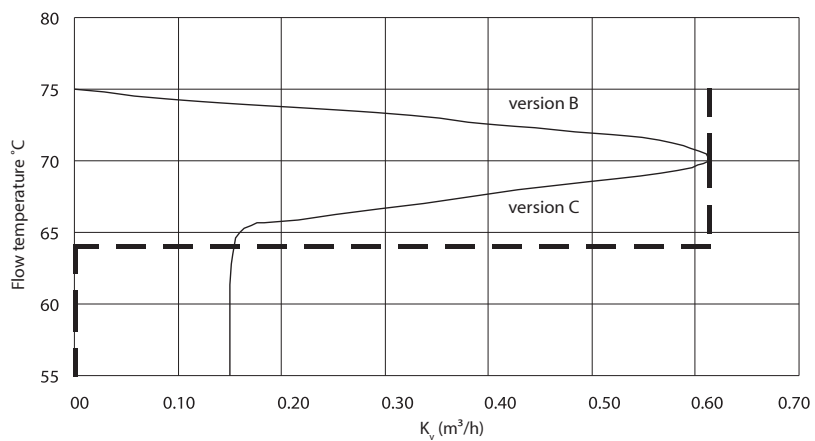

Example of calculation

Example:

The calculation is done for a 3-storey building with 8 risers.

The following assumptions were used in order to simplify calculation:

• Heat losses per meter of the pipe, $q_1 = 10 \text{ W/m}^*$

* during calculation it is required to calculate heat losses according to the country-specific standards

Usually the calculated heat losses are dependent on :

- The dimension of the pipe
- The materials used in insulations
- The ambient temperature where the pipe is located
- The efficiency and condition of insulation

• Inlet of hot water temperature, $T_{\text{sup}} = 55 \text{ }^\circ\text{C}$

• Temperature drop through the system, $\Delta T = 5 \text{ K}$

• Distance between risers, $L = 10 \text{ m}$

• Height of the risers, $l = 10 \text{ m}$

• Installation scheme as shown below:

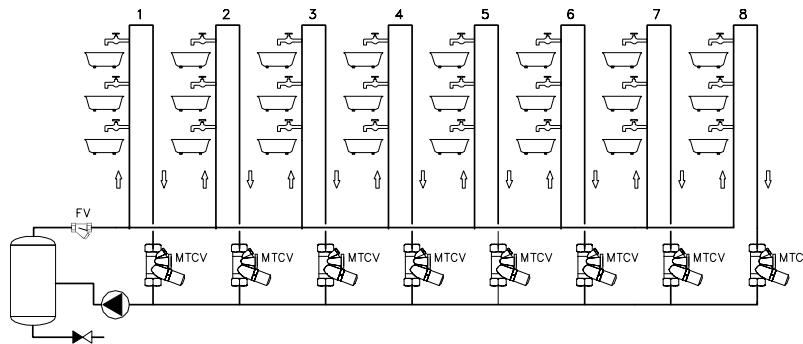

Fig. : Scheme of installation

I Basic operation

Calculation:

• calculation of heat losses in each riser (Q_r) and header (Q_h)

$$Q_r = l \text{ riser} \times q = (10 + 10) \times 10 = 200 \text{ W}$$

$$Q_h = l \text{ horiz.} \times q = 10 \times 10 = 100 \text{ W}$$

• The table below shows the results of the calculations:

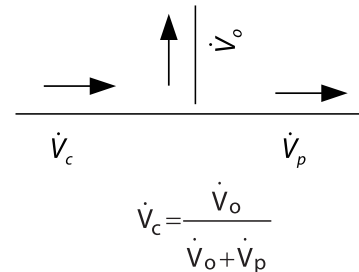

$$\dot{V}_c = \frac{\dot{V}_o}{\dot{V}_o + \dot{V}_p}$$

Riser	heat losses				Factor Risers	Flow in Each Part (l/h)	Total Flow (l/h)
	In risers	In header	Total in Each Part (W)	ΣQ total (W)			
	Qr (W)	Qh (W)					
1	200	100	300	2400	-	36	412
2				200	0.09	38	376
3				1800	0.1	40	339
4				1500	0.12	43	299
5				1200	0.14	47	256
6				900	0.18	52	210
7				600	0.25	63	157
8				300	0.4	94	94

• The total flow in the hot water circulation system is calculated using formula:

$$\dot{V} = \frac{\Sigma \dot{Q}}{r_{c_w} \Delta t_{hw}}$$

Σ Q - total heat losses in installation, (kW)

thus:

$$\dot{V}_C^{\text{total}} = \frac{2.4}{1 \times 4.18 \times 5} = 0.1141/\text{s} = 4121/\text{h}$$

The total flow in hot water circulation system is: 412 l/h - the circulation pump shall be sized for this flow.

• The flow in each riser is calculated using formula:

Flow in the riser number 1:

$$\dot{V}_0 = \dot{V}_c \times \frac{Q_0}{Q_0 + Q_p}$$

thus:

$$\dot{V}_0^1 = 412 \times \frac{200}{200 + 2100} = 35.841/\text{h} \approx 361/\text{h}$$

Flow in remaining risers should be calculated in the same way.

• The pressure drop in the system

Following assumptions were made to simplify calculation:

- Linear pressure drop, pl = 60 Pa/m (Linear pressure is the same for all pipes)

- Local pressure drop is equal to 33 % of total linear pressure drop, pr = 0.33 pl

thus:

$$p_r = 0.33 \times 60 = 19.8 \text{ Pa/m} \approx 20 \text{ Pa/m}$$

- For the calculation used

$$p_{\text{basic}} = p_r + p_l = 60 + 20 = 80 \text{ Pa/m}$$

- Local pressure drop across the MTCV is calculated on the basis of:

$$\Delta p_{\text{MTCV}} = \left(\frac{0.01 \times \dot{V}_0}{K_v} \right)^2$$

where:

K_v - according to fig. 19 page 10 in this case

$K_v = 0.366 \text{ m}^3/\text{h}$ for preset 50 °C

\dot{V}_0^* - flow through the MTCV at the flow temperature 50 °C (l/h)

Please note: during pressure drop calculation across the valve the temperature of circulation water has to be observed. MTCV - Multifunction Thermostatic Circulation Valve has variable K_v value which is dependent on two values: the preset temperature and the temperature of the flow temperature.

When the \dot{V}_0^* and K_v are known, the pressure drop across MTCV is calculated using the following formula:

$$\Delta p_{\text{MTCV}} = \left(\frac{0.01 \times \dot{V}_0}{K_v} \right)^2$$

thus:

$$\Delta p_{\text{MTCV}} = \left(\frac{0.01 \times 94}{0.366} \right)^2 = 6.59 \text{ kPa}$$

$$\Delta p_{\text{MTCV}} = (0.01 \times 94 / 0.366)^2 = 6.59 \text{ kPa}$$

• Differential pressure across the pump:

$$*p_{\text{pump}} = \Delta p_{\text{circuit}} + \Delta p_{\text{MTCV}} = 14.4 + 6.59 = 21 \text{ kPa}$$

Where:

$\Delta p_{\text{circuit}}$ - pressure drop in critical circuit (table below)

* p_{pump} - includes pressure drop across all devices in circulation installation like: boiler, strainer etc.

Riser	pressure drop			across the MTCV		Total Pressure Pump (kPa)
	In Risers (kPa)	In Header (kPa)	P _{circuit} (kPa)	V ₀ -flow (l/h)	ΔmMTCV Pressure Drop (kPa)	
1	1.6	1.6	14.4	36	0.97	21
2			12.8	38	1.07	
3			11.2	40	1.19	
4			9.6	43	1.38	
5			8.0	47	1.64	
6			6.4	52	2.01	
7			4.8	63	2.96	
8			3.2	94	6.59	

II Disinfection

The heat losses and pressure drop should be calculated according to new conditions.

- inlet hot water temperature during disinfection $T_{dis} = 70^\circ\text{C}$

- ambient temperature $*T_{amb} = 20^\circ\text{C}$

(* T_{amb} - according to standard and norm obligatory)

1. The heat losses are calculated from the formula:

$$q_1 = K_j \times l \times \Delta T_1 \rightarrow K_j \times l = q_1 / \Delta T_1 \text{ for basic process}$$

$$q_2 = K_j \times l \times \Delta T_2 \rightarrow K_j \times l = q_2 / \Delta T_2 \text{ for disinfection process}$$

Thus :

$$q_2 = q_1 \frac{\Delta T_2}{\Delta T_1} = q_1 \left(\frac{T_{dis} - T_{amb}}{T_{sup} - T_{amb}} \right)$$

for given case:

$$q_2 = 10 \left(\frac{70^\circ\text{C} - 20^\circ\text{C}}{55^\circ\text{C} - 20^\circ\text{C}} \right) = 14.3 \text{ W/m}$$

In this case during disinfection process heat losses increase for around 43 %.

2. Required flow

Due to sequence disinfection process (step by step) only critical circuit should be calculated.

For given case:

$$Q_{dis} = Q_f + Q_h$$

$$Q_{dis} = ((10+10) + (8 \times 10)) \times 14.3 \text{ W/m} = 1430 \text{ W} = 1.43 \text{ kW}$$

The flow:

$$\dot{V}_{dis} = \frac{1.43}{4.18 \times 5} = 0.06841 \text{ l/s} = 246 \text{ l/h}$$

3. The required pressure

The required pressure during the disinfection process should be checked

$$P_{dispump} = P_{dis(circuit)} + \Delta p_{MTCV}$$

where:

$$\Delta p_{MTCV} = \left(\frac{0.01 \times \dot{V}_0}{K_v} \right)^2$$

thus:

$$\Delta p_{MTCV} = \left(\frac{0.01 \times 246}{0.6} \right)^2 = 16.81 \text{ kPa}$$

Due to lower flow comparing to basic condition (412 l/h), pressure drop in the installation, $p_{circuit}$ should be recalculated.

$$\Delta p = \frac{\xi \rho w^2}{2}$$

where :

w - velocity of the water (m/s)

By comparing conditions during basic operation and disinfection one can estimate:

$$p_{dis} = p_{basic} \times \frac{V_{dis}^2}{V_c^2}$$

where :

V_{dis} - disinfection flow (l/h)

V_c - basic flow (l/h)

Thus:

- for first part of installation

$$p_{dis}^1 = 80 \times \left(\frac{246}{412} \right)^2 = 29 \text{ Pa/m}$$

This calculation should be done for all critical circuit. The table 5 shows the result of calculation.

For the critical circuit:

$$p_{dis(circuit)} = 0.57 + 0.68 + 0.84 + 1.08 + 1.48 + 2.20 + 3.93 + 21.92 = 32.70 \text{ kPa}$$

$$P_{dispump} = P_{dis(circuit)} + \Delta p_{MTCV} = 32.70 + 16.81 = 49.51 \text{ kPa}$$

The pump should be chosen to cover both requirements:

- basic operation,

$$V_0^* = 412 \text{ l/h and } p_{pump} = 21 \text{ kPa}$$

- disinfection operation

$$V_0^* = 246 \text{ l/h and } P_{pump} = 49.51 \text{ kPa}$$

pressure drop the circuit during disinfection process					Total pressure drop in critical circuit
Flow (l/h)		New Pressure Drop (Pa/m)	Length (m)	Pressure Drop (kPa)	
Basic	Disinfection				
412	246	29	20	0.57	32.70
376	246	34		0.68	
339	246	42		0.84	
299	246	54		1.08	
256	246	74		1.48	
210	246	110		2.20	
157	246	196	40	3.93	
94	246	548		21.92	
				Σ 32.70	

Dimensions

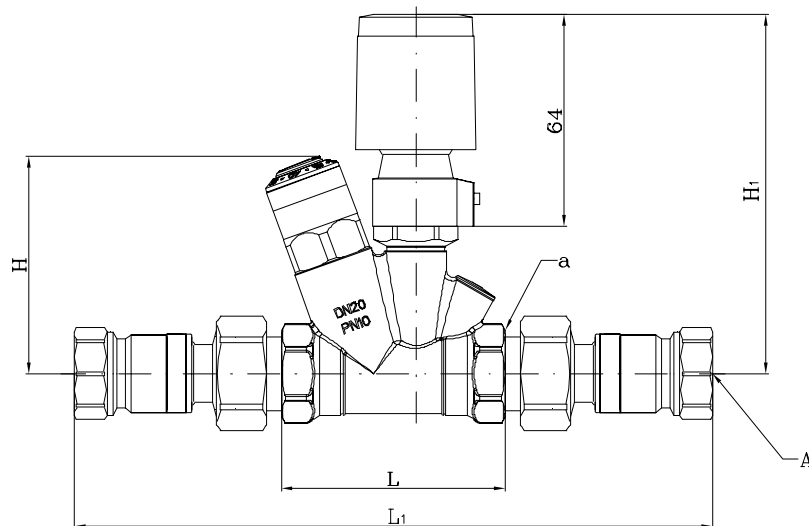

Internal Thread	A	a	H	H ₁	L	L ₁	Weight (kg)
	ISO 7/1		mm				
DN 15	Rp ½	Rp ½	79	129	75	215	0.56
DN 20	Rp ¾	Rp ¾	92	129	80	230	0.63

Certificates, declarations and approvals

The list contains all certificates, declarations, and approvals for this product type. Individual code number may have some or all of these approvals, and certain local approvals may not appear on the list.

When you click on the link you will be directed to the latest version of the 'Declaration of Conformity'. Products developed and sold before this date of issue conform to the directives/standards in force at the time of their sale.

Approval type	Title	Certification body	Approval topic
Construction Product Registration	Land Wien R-15.2.4-21-17495	LAND WIEN - Prüf- Inspektions- und Zertifizierungsstelle	Construction Product
Hygienic Certificate	MTCV Attestation of conformity 1085-0649	DVGW - Deutscher Verein des Gas- und Wasserfaches	Drinking Water
Hygienic Certificate	CARSO 25 ACC LY 058	CARSO - Laboratoire Santé Environnement Hygiène de Lyon	Drinking Water
Hygienic Certificate	PZH B.BK.60110.1016.2025	PZH - National Institute of Hygiene	Drinking Water
Hygienic Certificate	DVGW DW- 6340BO0482	DVGW - Deutscher Verein des Gas- und Wasserfaches	Drinking Water
Hygienic Certificate	WRAS 251102043	WRAS - Water Regulations Advisory Scheme	Drinking Water
Hygienic Certificate	Kiwa K 22839-04	KIWA	Drinking Water
Export Control Declaration	Butterfly, other valves, Manual balancing valves, one pipe solution valves and hot water balancing valves	Danfoss	
Manufacturer's Declaration	Danfoss MD BF206986516884en-000401.01	Danfoss	PED, Pressure, EU RoHS
UA Declaration	Danfoss UA 2023-01-23 MTC ASV RA FH RAX PL03 PL28	Danfoss	PED, Pressure
Pressure Safety Certificate	LLC CDC EURO-TYSK UA.TR.089.1011.01-22	LLC CDC EURO TYSK - Ukraine	PED, Pressure

Contact details

Online support

Danfoss offers a wide range of support along with our products, including digital information, software, mobile apps and expert guidance. See the possibilities below.



The Danfoss Design center

Discover the Design Center, our advanced digital platform that streamlines product selection. With integrated tools and enhanced type pages, it's simpler than ever to access product information and documentation, and to select the right products. Check the availability of Danfoss products at partner locations and enjoy seamless transitions from selection to purchase with our basket-to-basket functionality. Whether you're buying from our distributors or directly from the Product Store, the Design Center simplifies your experience. Learn more at: designcenter.danfoss.com.



The Danfoss product store

The Danfoss Product Store is a one-stop shop available 24/7 for our customers, no matter where you are in the world or what area of industry you work in. Browse our catalog, check product details and documentation, view your prices and product availability, and quickly finalize your purchase. Start browsing at: store.danfoss.com.



Danfoss Partner Portal/Product Data tool

Designed to support you with easy access to product data extracts, essential resources, tools, and information. The Partner Portal provides a centralized hub for product documentation, training materials, marketing assets, and technical support, ensuring you have everything you need to succeed and grow your business with Danfoss. The Partner Portal is available 24/7 at: partner.danfoss.com and is ready to support your business.



Find technical documentation

Find technical documentation you need to get your project up running. Get direct access to our official collection of data sheets, certificates and declarations, manuals and guides, 3D models and drawings, case stories, brochures, and much more. Start searching now at: documentation.danfoss.com.



Danfoss Learning

Danfoss Learning is a free online learning platform. It features courses and materials specifically designed to help engineers, installers, service technicians, and wholesalers better understand the products, applications industry topics, and trends that will help you do your job better. Find your local Danfoss website here: learning.danfoss.com.



Get local information and support

Local Danfoss websites are the main sources for help and information about our company and products. Find product availability, get the latest regional news, or connect with a nearby expert - all in your own language. Find your local Danfoss website here: danfoss.com.

Danfoss A/S

Climate Solutions . danfoss.com . +45 7488 2222

Any information, including, but not limited to information on selection of product, its application or use, product design, weight, dimensions, capacity or any other technical data in product manuals, catalogues description, advertisements, etc. and whether made available in writing, orally, electronically, online or via download, shall be considered informative, and is only binding if and to the extent, explicit reference is made in a quotation or order confirmation. Danfoss cannot accept any responsibility for possible errors in catalogues, brochures, videos and other material. Danfoss reserves the right to alter its products without notice. This also applies to products ordered but not delivered provided that such alterations can be made without changes to form, fit or function of the products. All trademarks in this material are property of Danfoss A/S or Danfoss group companies. Danfoss and the Danfoss logo are trademarks of Danfoss A/S. All rights reserved.
