

Axial Piston Open Circuit Pumps

X1P



Revision history

Table of revisions

Date	Changed	Rev
January 2026	Corrected several tables in Order code	0301
August 2025	Corrected verbiage	0202
April 2025	Global release	0201
April 2025	Preliminary release	0101

General Information

Overview.....	4
Design.....	4
Benefits.....	4
Typical applications.....	5
The X1P product family.....	5
Specifications.....	6
Load sensing open circuit system.....	6
Servo control orifice.....	6
Servo control orifice principle.....	7
Servo control orifice performance.....	7

Hydraulic Controls

Pressure compensated controls.....	9
PC frame specific information.....	10
Load sensing controls.....	11
LS frame specific information.....	12
LS control with bleed orifice.....	12
LS with bleed frame specific information.....	12

Electronic Controls

Fan drive control (FDC).....	14
Fan Drive Control system characteristics.....	14
FDC Frame specific information - Normally closed fan drive control.....	17
Angle Sensor.....	17
Sizing equations.....	19

Operating parameters

Fluids.....	20
Viscosity.....	20
Temperatures.....	20
Inlet pressure.....	20
Case pressure.....	21
Pressure ratings.....	21
Speed ratings.....	21
Duty cycle and pump life.....	21
Speed, flow, and inlet pressure.....	21

Design parameters

Installation.....	23
Filtration.....	23
Reservoir.....	23
Fluid velocity.....	23
Shaft loads.....	24
Bearing life.....	24
Mounting flange loads.....	24
Estimating overhung load moments.....	25
Auxiliary mounting pads.....	25
Input shaft torque ratings.....	26
Understanding and minimizing system noise.....	27
Understanding and minimizing system instability.....	27
LS system over-signaling.....	27

X1P - Frame C

Design.....	28
Technical specifications.....	28
Order code.....	28
Performance X1P-60.....	33
Performance X1PC-75.....	35
Input shaft.....	36
Installation drawings.....	37
Standard Radial ported endcap (non-optimized).....	38
Displacement limiters.....	38

General Information

Overview

X1P is a complete family of high-performance variable displacement, axial piston pumps. Each frame is designed to exceed the demanding work function requirements of the mobile equipment marketplace. Each frame within the X1P family is uniquely designed to optimize performance, size, and cost.

Design

High Performance

- Displacements from 60 cm³ - 75 cm³ [3.66 – 4.58 in³/rev]
- Speeds up to 2600 rpm
- Pressures up to 310 bar [4500 psi]
- Variety of control system options including load sensing and pressure compensated

Latest Technology

- Customer-driven using quality function deployment (QFD) and design for manufacturability (DFM) techniques
- Optimized design maximizes efficiency and quiet operation
- Computer-modeled castings to optimize inlet conditions for maximum pump speed
- Compact package size minimizing installation space requirements
- Heavy-duty tapered roller bearings for long life
- Single piece rigid housing to reduce noise and leak paths

Reliability

- Designed to rigorous standards
- Proven in both laboratory and field
- Manufactured to rigid quality standards
- Long service life
- Significantly fewer parts
- No gasket joints
- Robust input shaft bearings to handle large external shaft loads
- Integrated gauge ports for monitoring operating conditions
- State of the art cradle bearing for higher temperatures and increased efficiencies.

Benefits

Reduced Installation Costs

- Through-drive capability for multi-circuit systems
- Range of mounting flanges, shafts and porting options for ease of installation
- Compact size minimizes installation space requirements
- Help meet engine emission standards
- Reduce engine size by managing power usage more effectively

Reduced Operating Costs

- Optimize machine power usage to maximize fuel economy
- Simple design reduces service requirements
- Heavy duty taper roller shaft bearings provide long service life

Increased Customer Satisfaction

- Reduced noise for operator comfort
- High performance increases productivity

Reduced Heat Load on Cooling System

- High efficiency reduces hydraulic heat generation
- Allows for smaller cooling packages

Typical applications

- Cranes
- Telescopic handlers
- Forklift trucks
- Wheel loaders
- Sweepers
- Backhoe loaders
- Forestry and agricultural machinery
- Fan drives
- Paving Machines
- Mining Equipment
- Mowers
- Dozers
- Drilling Machines
- Mini-Excavators
- Other Applications

The X1P product family

Basic units

The X1P family of open circuit, variable piston pumps, offers a range of displacements from 60 to 75 cm³/rev [3.66 to 4.58in³/rev]. With maximum speeds up to 2600 rpm and continuous operating pressures up to 310 bar [4495 psi], product selection is easily tailored to the flow and pressure requirements of individual applications.

C Frame



Specifications

Pump Model		Frame C	
Maximum displacement	cm ³ [in ³]	60 [3.66]	75 [4.58]
Cont. working pressure	bar [psi]	310 [4500]	280 [4060]
Max working pressure		400 [5800]	350 [5075]
Continuous input speed	min ⁻¹ (rpm)	2600	2400
Theoretical flow	l/min [US gal/min]	156 [41.2]	180 [47.5]
Weight	kg [lb]	28.5 [62.8]	28.5 [62.8]

Load sensing open circuit system

The pump receives fluid directly from the reservoir through the inlet line. A screen in the inlet line protects the pump from large contaminants. The pump outlet feeds directional control valves such as PVG-32's, hydraulic integrated circuits (HIC), and other types of control valves. The PVG valve directs pump flow to cylinders, motors and other work functions. A heat exchanger cools the fluid returning from the valve. A filter cleans the fluid before it returns to the reservoir.

Flow in the circuit determines the speed of the actuators. The position of the PVG valve determines the flow demand. A hydraulic pressure signal (LS signal) communicates demand to the pump control. The pump control monitors the pressure differential between pump outlet and the LS signal and regulates servo pressure to control the swashplate angle. Swashplate angle determines pump flow.

Actuator load determines system pressure. The pump control monitors system pressure and will decrease the swashplate angle to reduce flow if system pressure reaches the PC setting. A secondary system relief valve in the PVG valve acts as a back-up to control system pressure.

General circuit diagram

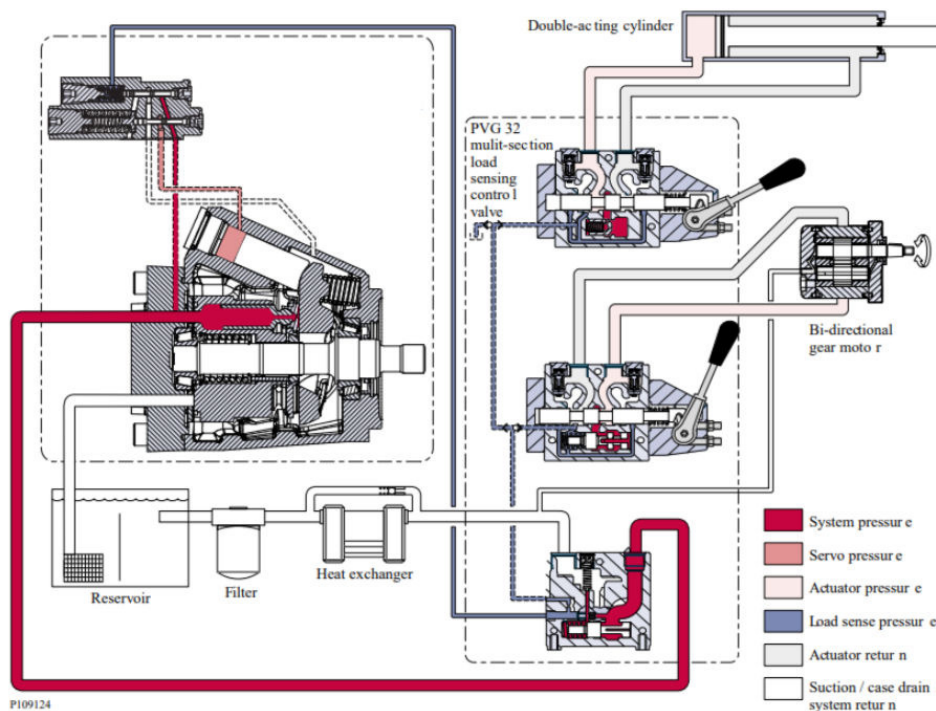

Servo control orifice

Servo control orifice principle

X1P controls offer an optional servo control orifice (not available with Pressure Compensation only Controls) available to aid in tuning system performance. The optional servo control orifice restricts flow to and from the servo system in the pump, effectively pacing the motion of the servo system.

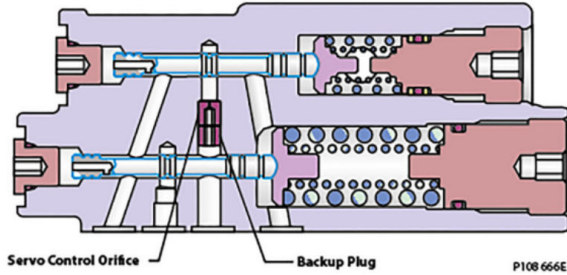

Servo control orifice performance

The use of the Servo Control Orifice will provide additional pacing to the pump, while the response of the pump to pressure spikes remains unaffected. The Pressure Compensation Function response and recovery, as well as the Load Sense Function response and recovery, are shown below and outline the relative impact in response and recovery of the Servo Control Orifices. Note that these graphs are meant as a generic comparison only.

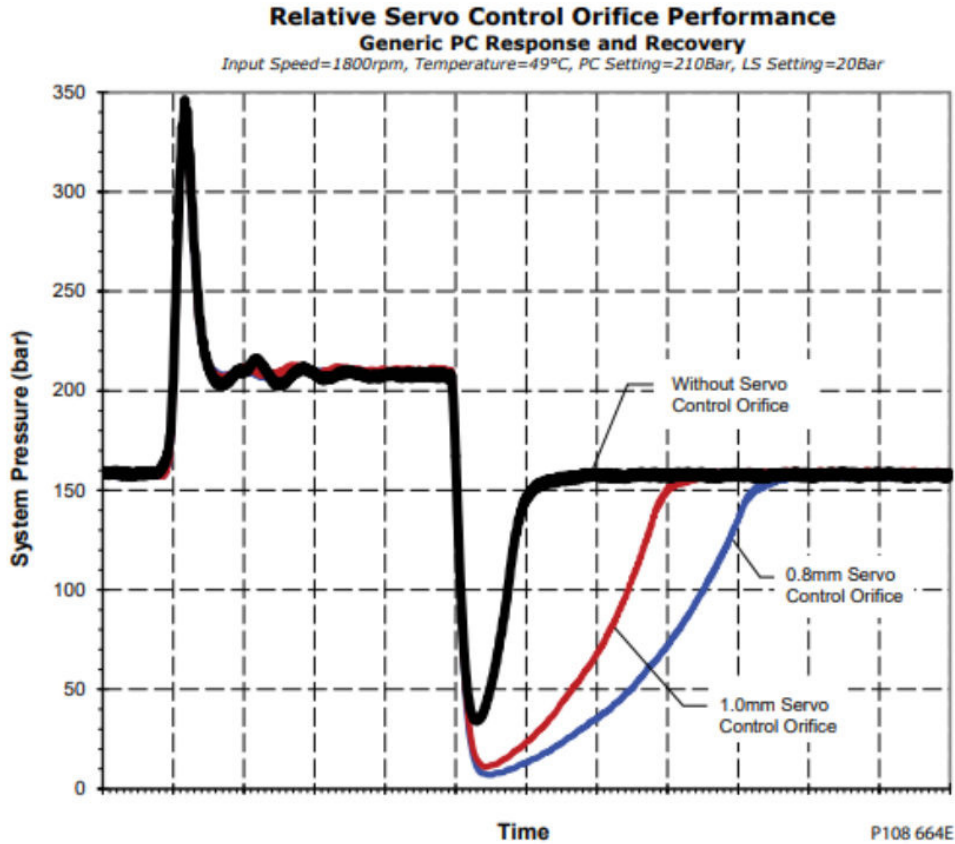

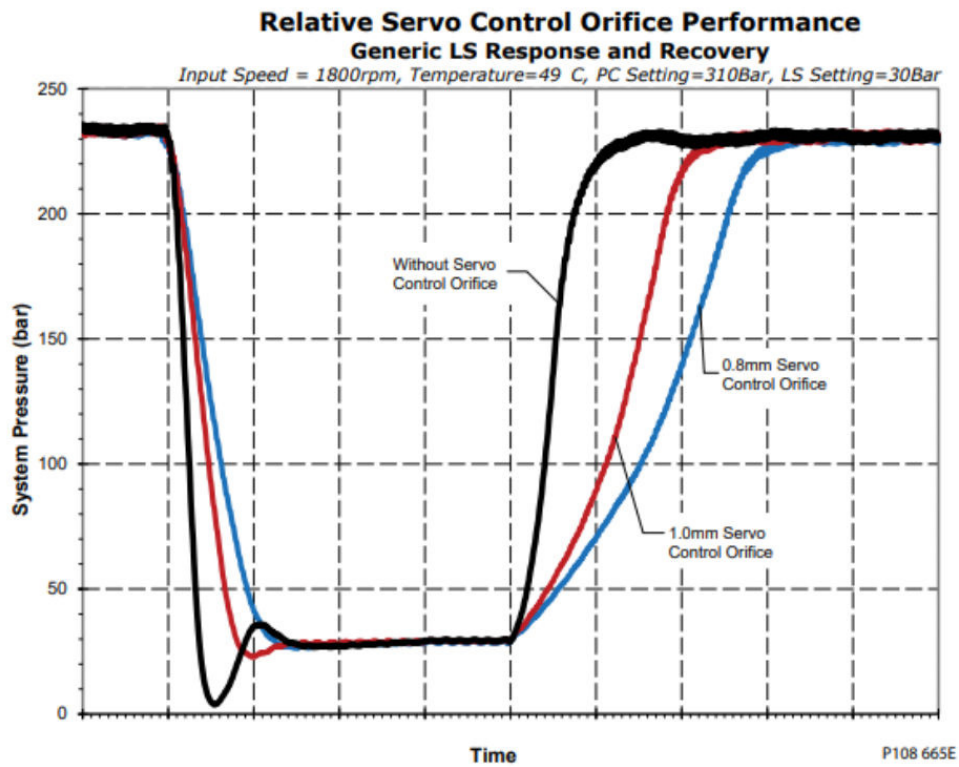

We recommend that systems experiencing instability use a Servo Control Orifice. Start with the largest size orifice available, and work down to the smaller size until the system is satisfactorily tuned. All Fan Drive systems should start with a 0.8mm Servo Control Orifice, if possible. Systems including motors are more likely to require the Servo Control Orifice option.

Hydraulic Controls

Pressure compensated controls

Operation

The PC control maintains constant system pressure in the hydraulic circuit by varying the output flow of the pump. Used with a closed center control valve, the pump remains in high pressure standby mode at the PC setting with zero flow until the function is actuated. This condition is often called a **dead head** condition.

Typical operating curve

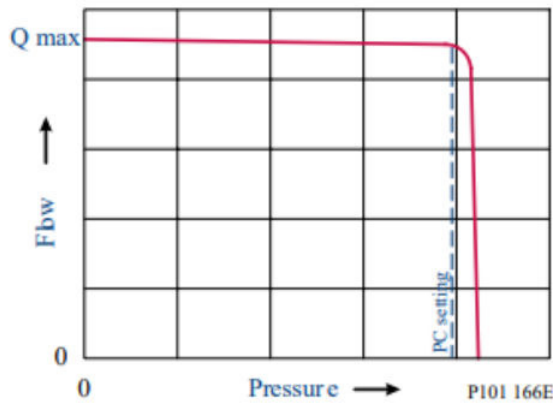

Simple closed-center circuit

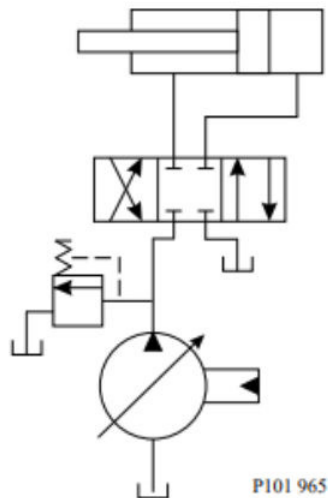

Once the closed center valve is opened, the PC control senses the immediate drop in system pressure and increases pump flow by increasing the swashplate angle. The pump continues to increase flow until system pressure reaches the PC setting. If system pressure exceeds the PC setting, the PC control reduces the swashplate angle to maintain system pressure by reducing flow. The PC control continues to monitor system pressure and changes the swashplate angle to match the output flow with the work function pressure requirements.

If the demand for flow exceeds the capacity of the pump, the PC control directs the pump to maximum displacement. In this condition, actual system pressure depends on the actuator load.

Each section includes control schematic diagrams, setting ranges, and response / recovery times for each control available. Response is the time (in milliseconds) for the pump to reach zero displacement when commanded by the control. Recovery is the time (in milliseconds) for the pump to reach full displacement when commanded by the control. Actual times can vary depending on application conditions.

Warning

A relief valve is required to be installed in the pump outlet for additional system protection. Failure to install a relief valve may lead to system damage and/or injury.

Pressure compensated system characteristics

- Constant pressure and variable flow
- High pressure standby mode when flow is not needed
- System flow adjusts to meet system requirements
- Single pump can provide flow to multiple work functions
- Quick response to system flow and pressure requirements

Typical applications for pressure compensated systems

- Constant force cylinders (bailers, compactors, refuse trucks)
- On/off fan drives
- Drill rigs
- Sweepers
- Trenchers

PC frame specific information

Response/recovery times

Control functionality	Displacement	Response [msec]	Recovery [msec]
Pressure compensator (PC)	60cc ¹	35	130
	75cc ²	30	140

¹ Pressure compensator (PC) Response from 230 bar to 310 bar, PC Recovery from 310 bar to 230 bar at 1800 rpm. Load sense (LS) Response from 230 bar to 20 bar, LS Recovery from 20 bar to 230 bar at 1800 rpm.

² Pressure compensator (PC) Response from 160 bar to 210 bar, PC Recovery from 210 bar to 160 bar at 1800 rpm. Load sense (LS) Response from 200 bar to 20 bar, LS Recovery from 20 bar to 200 bar at 1800 rpm.

PC control setting range

Model	Bar	Psi
60cc	100-310	1450-4495
75cc	100-260	1450-3770

PC with bleed schematic

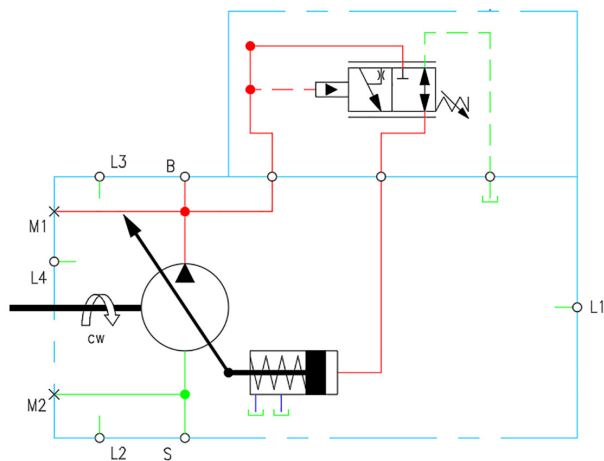

Load sensing controls

Operation

The LS control matches system requirements for both pressure and flow in the circuit regardless of the working pressure. Used with a closed center control valve, the pump remains in low-pressure standby mode with zero flow until the valve is opened. The LS setting determines standby pressure.

Typical operating curve

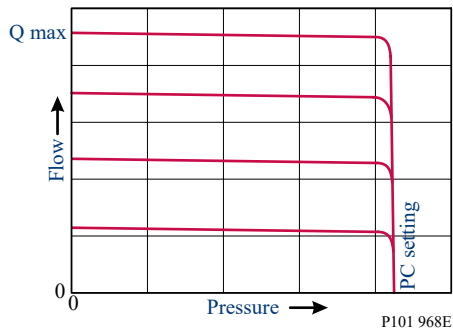

Load sensing circuit

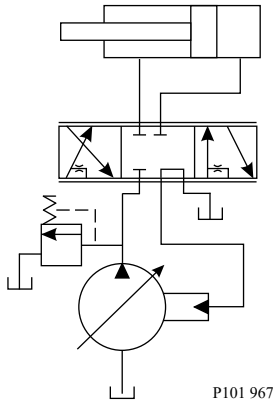

Most load sensing systems use parallel, closed center, control valves with special porting that allows the highest work function pressure (LS signal) to feed back to the LS control. Margin pressure is the difference between system pressure and the LS signal pressure. The LS control monitors margin pressure to read system demand. A drop in margin pressure means the system needs more flow. A rise in margin pressure tells the LS control to decrease flow.

Integral PC function

The LS control also performs as a PC control, decreasing pump flow when system pressure reaches the PC setting. The pressure compensating function has priority over the load sensing function.

Warning

A relief valve is required to be installed in the pump outlet for additional system protection. Failure to install a relief valve may lead to system damage and/or injury.

Load sensing system characteristics

- Variable pressure and flow
- Low pressure standby mode when flow is not needed
- System flow adjusted to meet system requirements
- Lower torque requirements during engine start-up
- Single pump can supply flow and regulate pressure for multiple circuits
- Quick response to system flow and pressure requirements

LS frame specific information

Response/recovery times

Control functionality	Displacement	Response [msec]	Recovery [msec]
Load sense (LS)	60cc ¹	37	150
	75cc ²	39	104

¹ Pressure compensator (PC) Response from 230 bar to 310 bar, PC Recovery from 310 bar to 230 bar at 1800 rpm. Load sense (LS) Response from 230 bar to 20 bar, LS Recovery from 20 bar to 230 bar at 1800 rpm.

² Pressure compensator (PC) Response from 160 bar to 210 bar, PC Recovery from 210 bar to 160 bar at 1800 rpm. Load sense (LS) Response from 200 bar to 20 bar, LS Recovery from 20 bar to 200 bar at 1800 rpm.

PC Control setting range

Model	Bar	Psi
60cc	100-310	1450-4495
75cc	100-260	1450-3770

LS Control setting range

Model	Bar	Psi
60cc	10-40	145-580
75cc		



LS control with bleed orifice

The load sense signal line requires a bleed orifice to prevent high-pressure lockup of the pump control. Most load-sensing control valves include this orifice. An optional internal bleed orifice is available, for use with control valves that do not internally bleed the LS signal to tank. Load Sensing control with Bleed Orifice/Pressure Compensated.

LS with bleed frame specific information

Load sensing control with bleed orifice/pressure compensated

Control functionality	Displacement	Response [msec]	Recovery [msec]
Load sense (LS)	60cc ¹	37	150
	75cc ²	39	104

¹ Pressure compensator (PC) Response from 230 bar to 310 bar, PC Recovery from 310 bar to 230 bar at 1800 rpm. Load sense (LS) Response from 230 bar to 20 bar, LS Recovery from 20 bar to 230 bar at 1800 rpm.

Load sensing control with bleed orifice/pressure compensated (continued)

Control functionality	Displacement	Response [msec]	Recovery [msec]
-----------------------	--------------	-----------------	-----------------

² Pressure compensator (PC) Response from 160 bar to 210 bar, PC Recovery from 210 bar to 160 bar at 1800 rpm. Load sense (LS) Response from 200 bar to 20 bar, LS Recovery from 20 bar to 200 bar at 1800 rpm.

PC control setting range

Model	Bar	Psi
60cc	100-310	1450-4495
75cc	100-260	1450-3770

Model	Bar	Psi
60cc	10-40	145-580
75cc		

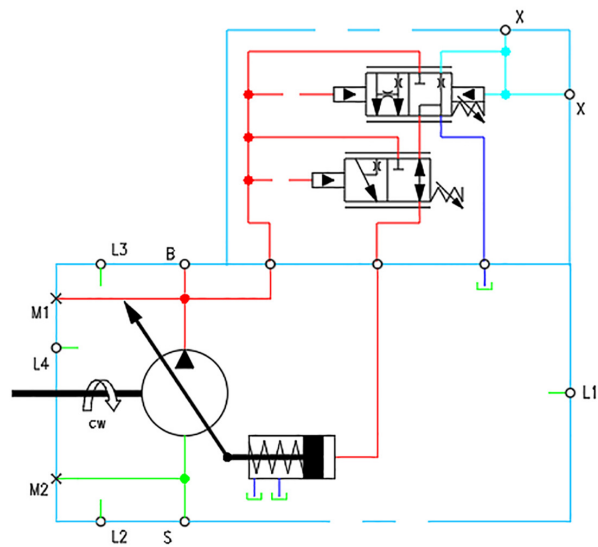

Electronic Controls

Fan drive control (FDC)

PLUS+1° Compliant

The Fan Drive control has met and passed the Danfoss PLUS+1° compliance standard testing. PLUS+1° compliance blocks are available on the Danfoss website, within the PLUS+1° GUIDE section.

Fan drive control principle

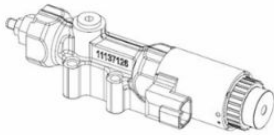

The Fan Drive Control is a unique electrically actuated pressure control solution that consists of a normally closed proportional solenoid and one dual diameter spool sliding in the control housing. System pressure acts on an area between the two spool diameters of the spool lands. This hydraulic force is balanced with forces of springs and the solenoid when the spool is in the metering position. When no current is sent to the solenoid it operates the pump at or below the PC setting which is adjusted mechanically with the adjustor screw and lock nut. Increasing the control current proportionally reduces the pump's outlet pressure until a minimum standby pressure is reached.

Control block 12V



The minimum system pressure is given by swashplate moments of the pump and by servo system leakages which produce a pressure drop across the control. In addition, fan motor type and fan inertia impact minimum system pressure.

The Normally Closed Fan Drive Control coupled with a microprocessor allows the pump to operate at an infinite range of operating pressures between a minimum system pressure and PC setting.

Warning

A relief valve is required to be installed in the pump outlet for additional protection. Failure to install a relief valve may lead to system damage and/or injury.

Caution

The Fan Drive Control is intended for fan drive systems only! Use in other systems could result in system component damage or unintended machine movement. The Fan Drive Control is not intended to serve as the primary system pressure relief. Loss of the input signal to this control will cause the pump to produce maximum flow.

Fan Drive Control system characteristics

Fan Drive Control System Characteristics

- Constant pressure and variable flow
- High or low system pressure mode based on fan cooling demand
- System flow adjusts to meet system requirements

Unintended Applications for Fan Drive Control Systems

- Applications with frequent PC events (system pressure overshoots)
- Adjustable Load Sensing systems

Fan drive control cross section

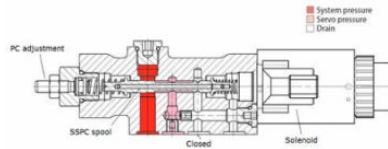

Fan Drive Control characteristic - Normally Closed

When an electric current is sent to the Normally Closed Fan Drive Control, pump outlet pressure decreases proportionally to the increase in current. When the load in the system changes, the pump will adjust its displacement to maintain the pressure demanded by the controlling current. This predictable control is especially useful for fan-drive systems, due to the direct relationship between fan-speed and pump pressure. Due to the nature of the Fan Drive Control, the relationship between current and pump pressure is unique for each individual PC pressure setting combination. The relationship between pump outlet pressure and control input current (for a 12V coil) is shown for various PC settings below. The hydraulic schematic for the Normally Closed Fan Drive Control is shown below as well.

Pump outlet pressure vs control input current 12V Normally closed FDC (at 100Hz PWM)

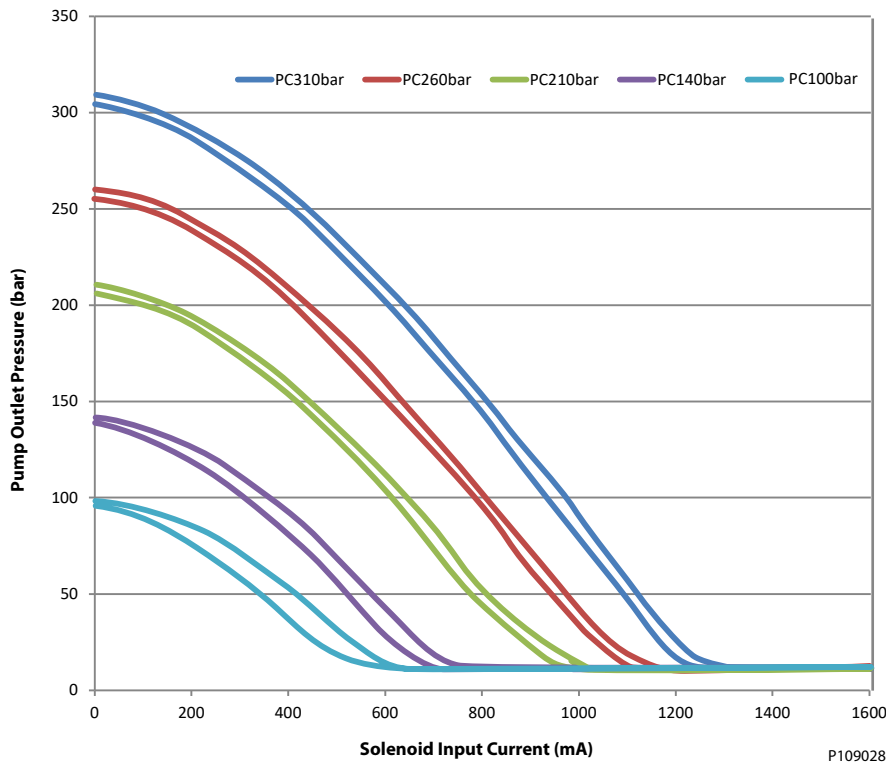

Attaining remarkably low system pressures is possible with the Fan Drive Control. The minimum system pressure is greatly dependent on individual system parameters such as fan motor type and size. This feature is highly desirable in low cooling demand conditions to keep fan speed as slow as possible.

Virtually eliminated control deadband increases controlability and reduces power loss. Control current resolution is greatly improved.

X1P pump with integrated Fan Drive control schematic

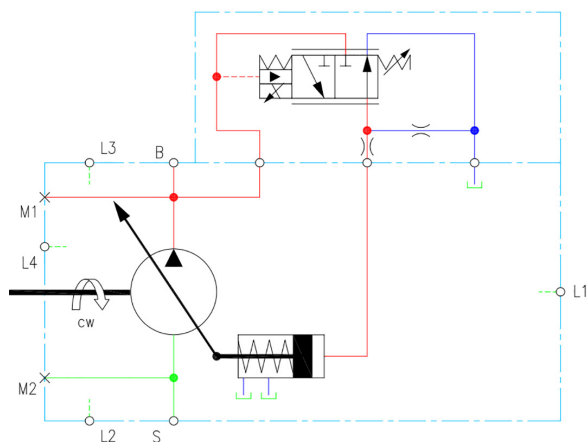

Solenoid data - normally closed

<input checked="" type="checkbox"/>	12V
Connector on solenoid	Deutsch DT04-2P
Mating Connector (not included)	Deutsch DT06-2S
Identification by color on nut	Black
Nominal Current	1650 mA
Maximum Control Current	1800 mA
Environmental Rating	IP67 without mating connector, IP69K with mating connector
Maximum output driver current	2.0 Amps
PLUS+1 dither frequency	Not Recommended
Useable PWM Frequency Range	50-200 Hz
Recommended PWM Frequency	200 Hz
Nominal Resistance at 20°C	3.66 Ω
Inductivity (pin at stroke end)	33 mH
Minimum Voltage	9.5 Vdc
Maximum power	17.9 Watts

The Fan Drive Control is designed as a current driven control. It requires a PWM- input signal.

Connectors

Description	Quantity	Ordering Number
Mating connector	1	DEUTSCH DT06-2S
Wedge lock	1	DEUTSCH W25
Socket Contact (16 and 18 AWG)	2	DEUTSCH 0462-201-16141
Danfoss mating connector kit	1	K29657



Continuous duty operating range

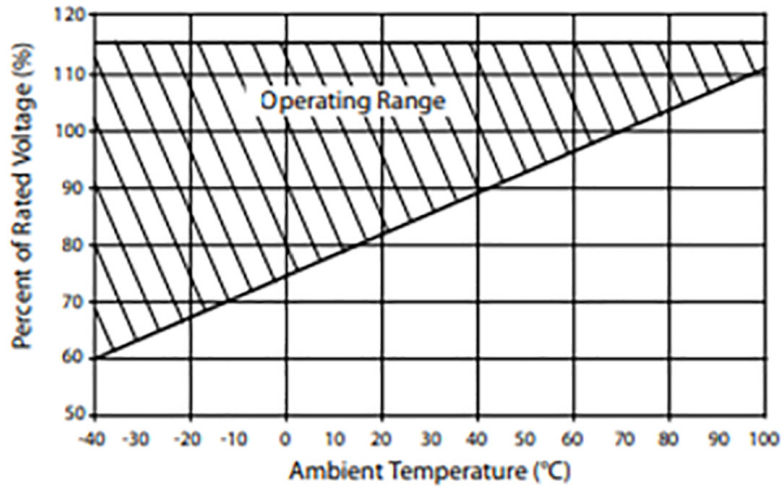

Solenoid data - normally closed

Voltage	12V
Threshold control [mA] (310/260 bar PC setting, oil temp X)	200/400
End current [mA] (20 bar LS setting, oil temp) X)	1200

Solenoid data - normally open

Voltage	12V
Threshold control [mA] (20 bar LS setting, oil temp X)	0
End current [mA] (260/310 bar PC setting, oil temp) X)	1000/1100

FDC Frame specific information - Normally closed fan drive control

Frame	SA (12V)	SC (12V)
60cc	100-210 bar	220-310 bar
75cc	[1450-3045 psi]	[3190-4496 psi]

Fan drive control schematic

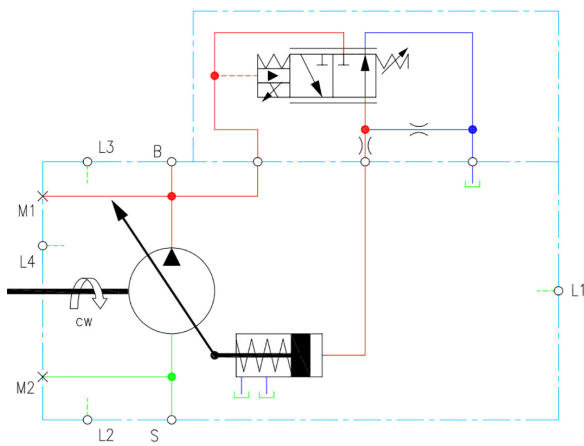

Angle Sensor

PLUS+1° Compliant

The X1P angle sensor has not met the Danfoss PLUS+1° compliance standards. Compliance and PLUS+1° blocks will be available on the Danfoss website soon.

Angle Sensor Principle

The angle sensor detects the swash plate position with an accuracy dependent upon the calibration effort done for the application.

The sensor works on the hall-effect technology. The implemented technology is based on a measurement of the magnetic field direction in parallel to the chip surface. This field direction is converted to a voltage signal at the output.

Enhanced calibration of the non-linear behavior leads to more exact calculation of the pump swashplate angle. The 4-pin DEUTSCH connector is part of the sensor housing.

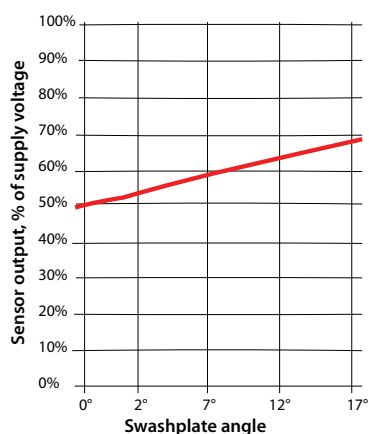
Swashplate angle vs. output of supply voltage**! Caution**

Avoid strong magnetic fields in the proximity of the sensor that can influence the sensor signal.

Contact your Danfoss representative if the angle sensor will be used for safety functions.

Parameter	Minimum	Typical	Maximum
Supply voltage range	4.5 V _{DC}	5 V _{DC}	5.5 V _{DC}
Supply protection	–	–	18 V _{DC}
Pump neutral output (% of supply voltage)	–	50%	–
Working range (swash plate angle)	0°	–	18°
Required supply current	–	–	30 mA
Output current signal	–	9 mA	11 mA
Working temperature	–40 °C	80 °C	115 °C

Electrical Protection	Standard	Class
IP Rating	IEC 60 529	IP 67
	DIN 40 050, part 9	IP 69K with mating connector
EMC Immunity	ISO 11452-2	100 V/m

Calibration of the sensor output within the software is mandatory. Vehicle neutral thresholds in the software ($\pm 0.5^\circ$) are vehicle dependent and must consider different condition, including, but not limited to system temperature, system pressure and/or shaft speed.

For safety function: If the sensor fails (invalid signal 90% of supply voltage), it must be sure that the ECU will go into a diagnostic mode and shift into limited mode. Avoid strong magnetic fields near the sensor that can influence the sensor signal.

Swashplate angle sensor connector

Connector DEUTSCH, 4-pin

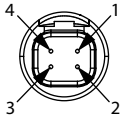

1	Ground (GND)
2	Not connected
3	Output signal 1 (Sig 1)
4	Supply (V+)

Description	Quantity	Order number
Mating connector	1	DEUTSCH DTM06-4S-E004
Wedge lock	1	DEUTSCH WM-4S
Socket contact	4	DEUTSCH 0462-201-2031
Blind socket	1	DEUTSCH 0413-204-2005
Danfoss mating connector kit	1	11212713

Sizing equations

Use these equations to help select the right pump size, displacement and power requirements for your application

Based on SI units

Based on US units

Flow	Output flow $Q = \frac{V_g \cdot n \cdot \eta_v}{1000}$ (l/min)	Output flow $Q = \frac{V_g \cdot n \cdot \eta_v}{231}$ (US gal/min)
Torque	Input torque $M = \frac{V_g \cdot \Delta p}{20 \cdot \pi \cdot \eta_m}$ (N·m)	Input torque $M = \frac{V_g \cdot \Delta p}{2 \cdot \pi \cdot \eta_m}$ (lbf·in)
Power	Input power $P = \frac{M \cdot n \cdot \pi}{30\,000} = \frac{Q \cdot \Delta p}{600 \cdot \eta_t}$ (kW)	Input power $P = \frac{M \cdot n \cdot \pi}{198\,000} = \frac{Q \cdot \Delta p}{1714 \cdot \eta_t}$ (hp)

Variables

- SI units [US units]
- V_g Displacement per revolution cm^3/rev [in^3/rev]
- p_o Outlet pressure bar [psi]
- p_i Inlet pressure bar [psi]
- Δp $p_o - p_i$ (system pressure) bar [psi]
- n Speed min^{-1} (rpm)
- η_v Volumetric efficiency
- η_m Mechanical efficiency
- η_t Overall efficiency ($\eta_v \cdot \eta_m$)

Operating parameters

Fluids

Ratings and performance data for X1P products are based on operating with premium hydraulic fluids containing oxidation, rust, and foam inhibitors. These include premium turbine oils, API CD engine oils per SAE J183, M2C33F or G automatic transmission fluids (ATF), Dexron II (ATF) meeting Allison C-3 or Caterpillar T02 requirements, and certain specialty agricultural tractor fluids. For more information on hydraulic fluid selection, see Danfoss publication **BC152886484524** Hydraulic Fluids and Lubricants, Technical Information, and 520L0465 Experience with Biodegradable Hydraulic Fluids, Technical Information.

Viscosity

Fluid viscosity limits

Condition		mm ² /s (cSt)	SUS
v min.	continuous	9	58
	intermittent	6.4	47
v max.	continuous	110	500
	intermittent (cold start)	1000	4700

Maintain fluid viscosity within the recommended range for maximum efficiency and pump life.

Minimum Viscosity – This should only occur during brief occasions of maximum ambient temperature and severe duty cycle operation.

Maximum Viscosity – This should only occur at cold start. Pump performance will be reduced. Limit speeds until the system warms up.

Temperatures

Temperature

Minimum ¹	-40°C [-40°F]
Rated	104° [220°F]
Recommended range ²	60 - 80°C [140 - 185°F]
Maximum intermittent	115°C [240°F]

¹ Cold start = Short term t. 3 min, p ≤ 50 bar [725 psi], n ≤ 1000 min⁻¹(rpm).

² At the hottest point, normally case drain port.

Ensure fluid temperature and viscosity limits are concurrently satisfied.

Inlet pressure

Inlet pressure limits

Minimum (continuous)	0.8 bar absolute [6.7 in. Hg vac.] (at reduced maximum speed)
Minimum (cold start)	0.5 bar absolute [15.1 in. Hg vac.]

Maintain inlet pressure within the limits shown in the table. Refer to Inlet pressure vs. speed charts for each displacement.

Case pressure

Case pressure limits

Maximum (continuous)	0.5 bar [7 psi] above inlet
Intermittent (cold start)	2 bar [29 psi] above inlet

Maintain case pressure within the limits shown in the table. The housing must always be filled with hydraulic fluid.

Caution

Operating outside of inlet and case pressure limits will damage the pump. To minimize this risk, use full size inlet and case drain plumbing, and limit line lengths.

Pressure ratings

The specification tables in each section give maximum pressure ratings for each displacement. Not all displacements within a given frame operate under the same pressure limits. Definitions of the operating pressure limits appear below.

Continuous working pressure is the average, regularly occurring operating pressure. Operating at or below this pressure should yield satisfactory product life. For all applications, the load should move below this pressure. This corresponds to the maximum allowable PC setting.

Maximum (peak) working pressure is the highest intermittent pressure allowed. Maximum machine load should never exceed this pressure, and pressure overshoots should not exceed this pressure.

[See Duty cycle and pump life.](#)

Speed ratings

The specification tables in each section give minimum, maximum, and rated speeds for each displacement. Not all displacements within a given frame operate under the same speed limits. Definitions of these speed limits appear below.

Rated speed is the fastest recommended operating speed at full displacement and 1 bar abs. [0 in Hg vac] inlet pressure. Operating at or below this speed should yield satisfactory product life.

Maximum speed is the highest recommended operating speed at full power conditions. Operating at or beyond maximum speed requires positive inlet pressure and/or a reduction of pump outlet flow. Refer to Inlet pressure vs. speed charts for each displacement.

Minimum speed is the lowest operating speed allowed. Operating below this speed will not yield satisfactory performance.

Duty cycle and pump life

Knowing the operating conditions of your application is the best way to ensure proper pump selection. With accurate duty cycle information, your Danfoss representative can assist in calculating expected pump life.

Speed, flow, and inlet pressure

Inlet pressure vs. speed charts in each section show the relationship between speed, flow, and inlet pressure for each displacement. Use these charts to ensure your application operates within the prescribed range.

The charts define the area of inlet pressures and speeds allowed for a given displacement. Operating at lower displacements allows greater speed or lower inlet pressure.

Sample inlet pressure vs. speed chart

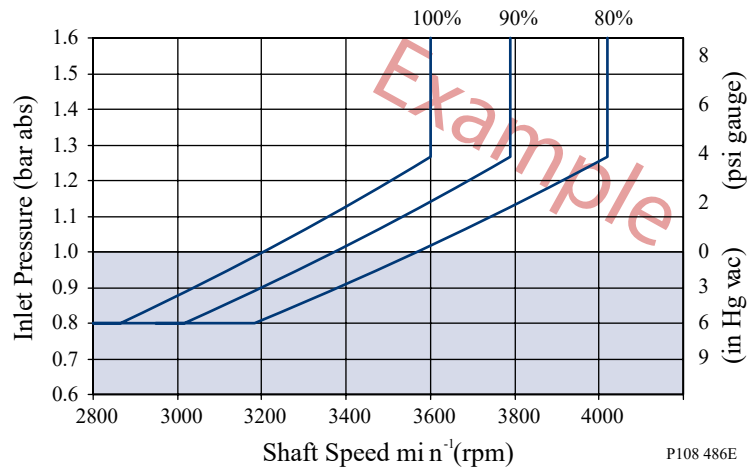

Design parameters

Installation

X1P pumps may be installed in any position. To optimize inlet conditions, install the pump at an elevation below the minimum reservoir fluid level. Design inlet plumbing to maintain inlet pressure within prescribed limits (see Inlet pressure limits)

Fill the pump housing and inlet line with clean fluid during installation. Connect the case drain line to the uppermost drain port to keep the housing full during operation.

To allow unrestricted flow to the reservoir, use a dedicated drain line. Connect it below the minimum reservoir fluid level and as far away from the reservoir outlet as possible. Use plumbing adequate to maintain case pressure within prescribed limits (see **Case pressure limits**).

Filtration

To prevent damage to the pump, including premature wear, fluid entering the pump inlet must be free of contaminants. X1P pumps require system filtration capable of maintaining fluid cleanliness at ISO 4406-1999 class 22/18/13 or better.

Danfoss does not recommend suction line filtration. Suction line filtration can cause high inlet vacuum, which limits pump operating speed. Instead, we recommend a 125 µm (150 mesh) screen in the reservoir covering the pump inlet. This protects the pump from coarse particle ingestion.

Return line filtration is the preferred method for open circuit systems. Consider these factors when selecting a system filter:

- Cleanliness specifications
- Contaminant ingress rates
- Flow capacity
- Desired maintenance interval

Typically, a filter with a beta ratio of $\beta_{10} = 10$ is adequate. However, because each system is unique, only a thorough testing and evaluation program can fully validate the filtration system. For more information, see Danfoss publication **BC152886482150** Design Guidelines for Hydraulic Fluid Cleanliness.

Reservoir

The reservoir provides clean fluid, dissipates heat, and removes air from the hydraulic fluid. It allows for fluid volume changes associated with fluid expansion and cylinder differential volumes. Minimum reservoir capacity depends on the volume needed to perform these functions. Typically, a capacity of one to three times the pump flow (per minute) is satisfactory.

Locate the reservoir outlet (suction line) near the bottom, allowing clearance for settling foreign particles. Place the reservoir inlet (return lines) below the lowest expected fluid level, as far away from the outlet as possible.

Fluid velocity

Choose piping sizes and configurations sufficient to maintain optimum fluid velocity, and minimize pressure drops. This reduces noise, pressure drops, and overheating. It maximizes system life and performance.

Recommended fluid velocities

System lines	6 to 9 m/sec [20 to 30 ft/sec]
Suction line	1 to 2 m/sec [1 to 2 ft/sec]
Case drain	3 to 5 m/sec [10 to 15 ft/sec]

Typical guidelines; obey all pressure ratings

Velocity equations

SI units Q	flow (l/min) [US gallons/min]
A=Area	(mm ²) [in ²]
Velocity	flow (l/min) [US gallons/min]
Velocity [U.S.]	(0.321 • Q)/A(ft/sec)

Shaft loads

X1P pumps have tapered roller bearings capable of accepting external radial and thrust (axial) loads. The external radial shaft load limits are a function of the load position, orientation, and the operating conditions of the pump.

The maximum allowable radial load (Re) is based on the maximum external moment (Me) and the distance (L) from the mounting flange to the load. Compute radial loads using the formula below. Tables in each section give maximum external moment (Me) and thrust (axial) load (Tin, Tout) limits for each pump frame size and displacement.

Radial load formula

$Me = Re \cdot L$

L = Distance from mounting flange to point of load

Me = Maximum external moment

Re = Maximum radial side load

Shaft load orientation

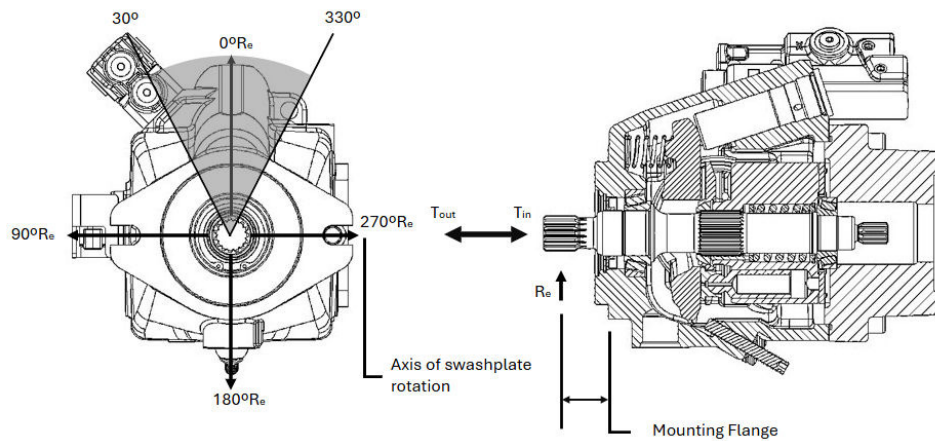

Bearing life

All shaft loads affect bearing life. In applications where external shaft loads cannot be avoided, maximize bearing life by orientating the load between the 30° and 330° positions, as shown. Tapered input shafts or clamp-type couplings are recommended for applications with radial shaft loads

Mounting flange loads

Adding auxiliary pumps and/or subjecting pumps to high shock loads may overload the pump mounting flange. Tables in each section give allowable continuous and shock load moments for each frame size. Applications with loads outside allowable limits require additional pump support.

- Shock load moment (MS) is the result of an instantaneous jolt to the system.
- Continuous load moments (Mc) are generated by the typical vibratory movement of the application.

Estimating overhung load moments

Use the equations below to estimate the overhung load moments for multiple pump mounting. See installation drawings in each section to find the distance from the mounting flange to the center of gravity for each frame size. Refer to the technical specifications in each section to find pump weight.

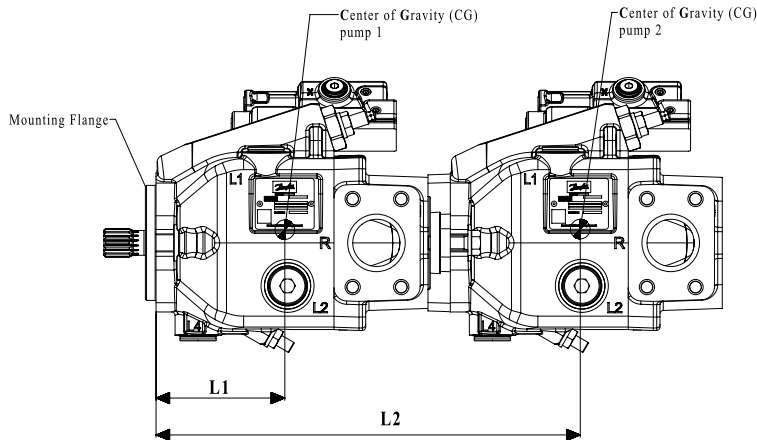

Shock load formula

- $M_s = G_s \cdot K \cdot (W_1 \cdot L_1 + W_2 \cdot L_2 + \dots W_n \cdot L_n)$

Continuous load formula

- $M_c = G_c \cdot K \cdot (W_1 \cdot L_1 + W_2 \cdot L_2 + \dots W_n \cdot L_n)$

SI units

- M_s = Shock load moment (N•m)
- M_c = Continuous (vibratory) load moment (N•m)
- G_s = Acceleration due to external shock (G's)
- G_c = Acceleration due to continuous vibration (G's)
- K = Conversion factor = 0.00981
- W_n = Mass of nth pump (kg)
- L_n = Distance from mounting flange to nth pump CG (mm)

SI units

- M_s = Shock load moment (N•m)
- M_c = Continuous (vibratory) load moment (N•m)
- G_s = Acceleration due to external shock (G's)
- G_c = Acceleration due to continuous vibration (G's)
- K = Conversion factor = 0.00981
- W_n = Mass of nth pump (kg)
- L_n = Distance from mounting flange to nth pump CG (mm)

Auxiliary mounting pads

Auxiliary mounting pads are available for all radial ported X1P pumps. Since the auxiliary pad operates under case pressure, use an O-ring to seal the auxiliary pump mounting flange to the pad. Oil from the main pump case lubricates the drive coupling.

- All mounting pads meet SAE J744 Specifications.
- The combination of auxiliary shaft torque and main pump torque must not exceed the maximum pump input shaft rating. Tables in each section give input shaft torque ratings for each frame size.

- Applications subject to severe vibratory or shock loading may require additional support to prevent mounting flange damage. Tables in each section give allowable continuous and shock load moments for each frame size.
- The drawing and table below give mating pump dimensions for each size mount. Refer to installation drawings in each section for auxiliary mounting pad dimensions.

Mating pump specifications

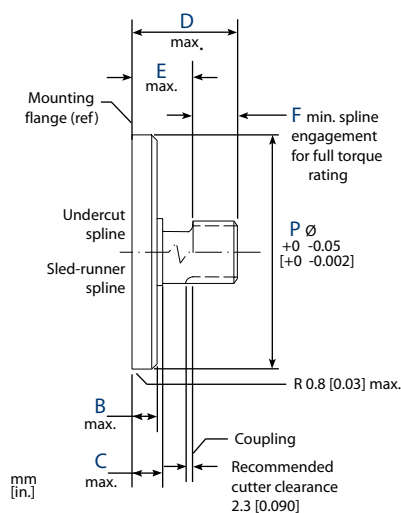

Dimensions

	SAE A	SAE B	SAE C
P	82.55 [3.250]	101.60 [4.000]	127.00 [5.000]
B	6.35 [0.250]	9.65 [0.380]	12.70 [0.500]
C	12.70 [0.500]	15.20 [0.600]	23.37 [0.920]
D	58.20 [2.290]	53.10 [2.090]	55.60 [2.190]
E	15.00 [0.590]	17.50 [0.690]	30.50 [1.200]
F	13.50 [0.530]	14.20 [0.560]	18.30 [0.720]

Input shaft torque ratings

Input shaft tables in each section give maximum torque ratings for available input shafts. Ensure that your application respects these limits.

Maximum torque ratings are based on shaft strength. Do not exceed them.

Coupling arrangements that are not oil-flooded provide a reduced torque rating. Contact your Danfoss representative for proper torque ratings if your application involves non-oil-flooded couplings.

Danfoss recommends mating splines adhere to ANSI B92.1-Class 6e. Danfoss external splines are class 5 fillet root side fit. Tolerance classes 5 and 6e have the same minimum effective space width and maximum effective tooth thickness limits to ensure interchangeability between mating parts. Tables in each section give full spline dimensions and data.

- Use flexible hoses.
- Limit system line length.
- If possible, optimize system line position to minimize noise.
- If you must use steel plumbing, clamp the lines.
- If you add additional support, use rubber mounts.
- Test for resonates in the operating range, if possible avoid them.

Understanding and minimizing system noise

Charts in each section give sound levels for each frame size and displacement. Sound level data are collected at various operating speeds and pressures in a semi-anechoic chamber. Many factors contribute to the overall noise level of any application. Below is some information to help understand the nature of noise in fluid power systems, and some suggestions to help minimize it.

Noise is transmitted in fluid power systems in two ways: as fluid borne noise, and structure borne noise.

Fluid-borne noise (pressure ripple or pulsation) is created as pumping elements discharge oil into the pump outlet. It is affected by the compressibility of the oil, and the pump's ability to transition pumping elements from high to low pressure. Pulsations travel through the hydraulic lines at the speed of sound (about 1400 m/sec [4600 ft/sec] in oil) until there is a change (such as an elbow) in the line. Thus, amplitude varies with overall line length and position.

Structure-borne noise is transmitted wherever the pump casing connects to the rest of the system. The way system components respond to excitation depends on their size, form, material, and mounting.

System lines and pump mounting can amplify pump noise. Follow these suggestions to help minimize noise in your application:

- Use flexible hoses.
- Limit system line length.
- If possible, optimize system line position to minimize noise.
- If you must use steel plumbing, clamp the lines.
- If you add additional support, use rubber mounts.
- Test for resonates in the operating range, if possible avoid them.

Understanding and minimizing system instability

Knowing the operating conditions and system setup of your application is the best way to ensure a stable system. All fan-drive circuits should use a choke orifice to ensure system stability. With accurate system information, your Danfoss representative can assist you in the selection of a servo control orifice.

LS system over-signaling

To optimize the life and performance of X1P products using Load Sensing controls, it is important to ensure the margin pressure signal at the pump's control is conditioned in a way which does not damage the control's internal components.

Caution

Excessive component wear may occur when margin pressures > 60 bar are imposed on the LS spool. Reduce margin pressures to 60 bar or less.

Margin pressure defines the physical movement of the LS spool and subsequent modulation of pump flow to the system and is defined by:

$$PMargin = PSystem - PLoad \text{ Sense Margin Pressure}$$

LS System Over-Signaling results when the actual margin pressure magnitude exceeds the minimum pressure required to shift the LS spool. It is important to limit excessive margin pressures in transient system conditions to ensure satisfactory control component life.

For more information on LS System Over-signaling please contact your Danfoss Representative.

X1P - Frame C

Design

X1P - Frame C pumps have a single servo piston design with a cradle-type swashplate set in roller bearings. A bias spring and internal forces increase swashplate angle. The servo piston decreases swashplate angle. Nine reciprocating pistons displace fluid from the pump inlet to the pump outlet as the cylinder block rotates on the pump input shaft. The block spring holds the piston slippers to the swashplate via the slipper retainer. The cylinder block rides on a bi-metal valve plate optimized for high volumetric efficiency and low noise. Tapered roller bearings support the input shaft and a Viton lip-seal protects against shaft leaks.

An adjustable one spool (PC only, not shown) or two spool (LS and remote PC) control senses system pressure and load pressure (LS controls). The control ports system pressure to the servo piston, adjusting swashplate angle to control pump output flow.

Frame X1P cross section

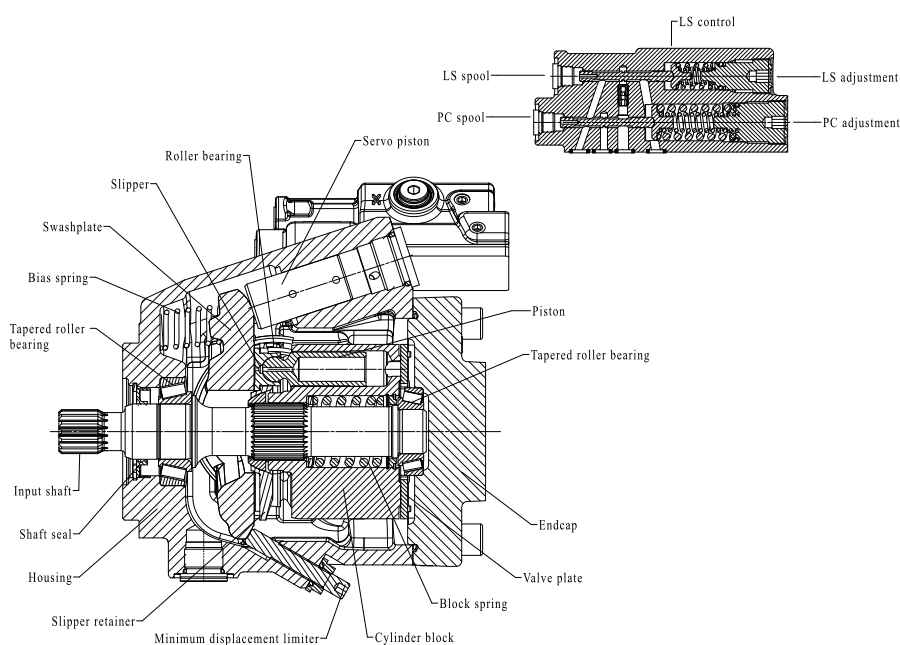

Technical specifications

Specifications

Pump Model		Frame C	
Maximum displacement	cm ³ [in ³]	60 [3.66]	75 [4.58]
Cont. working pressure	bar [psi]	310 [4500]	280 [4060]
Max working pressure		400 [5800]	350 [5075]
Continuous input speed	min ⁻¹ (rpm)	2600	2400
Theoretical flow	l/min [US gal/min]	156 [41.2]	180 [47.5]
Weight	kg [lb]	28 [61.7]	28 [61.7]

Order code

X1-A-B-W-D-E-F-G-H-I-J-K-L-M-N-P-C-R-S-T-U-V-X-Y-Z

Code	Description
X1	Platform
A	Product
B	Frame
W	Product Version
D	Rotation
E	Port Thread Type
F	Displacement
G	Minimum Displacement
H	Maximum Displacement
J	Input Shaft
K	Shaft Seal
L	Housing Flange and Ports
M	Endcap Type and Ports
N	Auxiliary Pad
P	Coupling
C	Control Hardware
R	Orifices
S	Technology Group
T	Pressure Compensating Setting
U	Load Sensing Setting
V	Power and Torque Setting
X	Sensor Group
Y	Special Hardware
Z	Paint and Nametag

A - Product		X1PC	
		60cc	75cc
P	Product family	x	x

B - Frame		X1PC	
		60cc	75cc
C	Frame Size	x	x

W - Product Version		X1PC	
		60cc	75cc
A	Initial Product	x	x

D - Rotation		X1PC	
		60cc	75cc
R	Right Hand (CW)	x	x

E - Port Thread Type		X1PC	
		60cc	75cc
M	Metric	x	x

F - Displacement		X1PC	
		60cc	75cc
C060	60cc	x	
C075	75cc		x

G- Minimum Displacement Limiter		X1PC	
		60cc	75cc
NNN	None, Plugged	x	x
G00	Adjustable -0% of Max Flow	x	x

H - Maximum Displacement Limiter		X1PC	
		60cc	75cc
PLB	None, Plugged	x	x
HHH	Adjustable - 100% of Max Flow	x	x

J - Input Shaft		X1PC	
		60cc	75cc
AN	Splined 13 tooth 16/32, No Aux	x	x
BN	Splined 14 tooth 12/24, No Aux	x	x
DN	Splined 15 tooth 16/32, No Aux	x	x
AT	Splined 13 tooth 16/32, 23 tooth 24/48 aux shaft end	x	x
BT	Splined 14 tooth 12/24, 23 tooth 24/48 aux shaft end	x	x
DT	Splined 15 tooth 16/32, 23 tooth 24/48 aux shaft end	x	x

K - Shaft Seal		X1PC	
		60cc	75cc
A	Single Fluorocarbon Rubber	x	x

L - Housing Flange and Ports		X1PC	
		60cc	75cc
AL	SAE B - 2 Bolt - 4 case drains - ISO 6149-1 O-ring M22x1.5 - No Angle Sensor- With Min Displacement Limiter	x	x
AN	SAE B - 2 Bolt - 4 case drains - ISO 6149-1 O-ring M22x1.5 - With Min Displacement Limiter	x	x
BM	SAE C - 4 Bolt - 4 case drains - ISO 6149-1 O-ring M22x1.5 - No angle sensor- With Min Displacement Limiter	x	x

M - Endcap Type and Ports		X1PC	
		60cc	75cc
HA	Radial Code 61 - Inlet 2in M12, Outlet 1in M10 - Gage ports ISO 6149-1 O-ring M14x1.5 - Standard Aux	x	x

N - Auxiliary Pad		X1PC	
		60cc	75cc
R	Running Cover	x	x
A	SAE A - 2 Bolt - M10 x 1.5-6H	x	x
C	Integral A - 2 Bolt - M10 x 1.5-6H	x	x
D	SAE B - 2 Bolt - M12 x 1.75-6H	x	x
G	SAE C - 4 Bolt - M12 x 1.75-6H	x	x

P -Coupling		X1PC	
		60cc	75cc
A	SAE A - 9 Tooth 16/32 Pitch	x	x
B	SAE A - 11 Tooth 16/32 Pitch	x	x
C	SAE B - 13 tooth 16/32 Pitch	x	x

P-Coupling		X1PC	
		60cc	75cc
D	SAE BB - 15 Tooth 16/32 Pitch	x	x
E	SAE C - 14 Tooth 12/24 Pitch	x	x
F	SAE A - 9 Tooth 16/32 Pitch with Integral Aux	x	x
N	None	x	x

C - Control Types		X1PC	
		60cc	75cc
PC	PC only - 100/280 Bar	x	x
BS	PC 290-310 Bar - LS 10-40 Bar - X-port M=M12x1.5-6H ISO 6149-1	x	x
SA	FDC - PC 200-210 bar - 12 VDC	x	x
SC	FDC - PC 220-310 bar - 12 VDC	x	x
SB	FDC - PC 100-210 bar - 24 VDC	x	x
SD	FDC - PC 220-310 bar - 24VDC	x	x
LS	PC 100-280 Bar - LS 10-40 Bar - X-port M=M12x1.5-6H ISO 6149-1	x	x
LB	PC 100-280 Bar - LS 10-40 Bar - X-port M=M12x1.5-6H ISO 6149-1 - With Bleed Orifice	x	x
BB	PC 290-310 Bar - LS 10-40 Bar - X-port M=M12x1.5-6H ISO 6149-1 - With Bleed Orifice	x	x
RP	Remote PC - 100-280 bar	x	x
BP	Remote PC - 290-310 bar	x	x

R - Orifices		X1PC	
		60cc	75cc
PN	Gain Orifice - No Semi Choke Orifice	x	x
PA	0.8mm gain orifice	x	x
PB	1.0mm gain orifice	x	x
PC	1.2mm gain orifice	x	x
KA	FDC 0.8 Full Choke	x	x

S - Technology Group		X1PC	
		60cc	75cc
ND	Pressure Controlled - 60cc	x	☒
NG	Pressure Controlled - 75cc	☒	x

T - PC Setting		X1PC	
		60cc	75cc
NN	NONE	x	x
10	100 BAR (1450 PSI)	x	x
11	110 BAR (1595 PSI)	x	x
12	120 BAR (1740 PSI)	x	x
13	130 BAR (1885 PSI)	x	x
14	140 BAR (2030 PSI)	x	x
15	150 BAR (2175 PSI)	x	x
16	160 BAR (2320 PSI)	x	x
17	170 BAR (2465 PSI)	x	x
18	180 BAR (2610 PSI)	x	x
19	190 BAR (2755 PSI)	x	x
20	200 BAR (2900 PSI)	x	x

T - PC Setting		X1PC	
		60cc	75cc
21	210 BAR (3045 PSI)	x	x
22	220 BAR (3190 PSI)	x	x
23	230 BAR (3335 PSI)	x	x
24	240 BAR (3480 PSI)	x	x
25	250 BAR (3625 PSI)	x	x
26	260 BAR (3770 PSI)	x	x
27	270 BAR (3915 PSI)	x	☒
28	280 BAR (4060 PSI)	x	☒
29	290 BAR (4205 PSI)	x	☒
30	300 BAR (4350 PSI)	x	☒
31	310 BAR (4495 PSI)	x	☒

U - LS Setting		X1PC	
		60cc	75cc
NN	NONE	x	x
10	10 BAR (145 PSI)	x	x
11	11 BAR (159 PSI)	x	x
12	12 BAR (174 PSI)	x	x
13	13 BAR (189 PSI)	x	x
14	14 BAR (203 PSI)	x	x
15	15 BAR (218 PSI)	x	x
16	16 BAR (232 PSI)	x	x
17	17 BAR (247 PSI)	x	x
18	18 BAR (261 PSI)	x	x
19	19 BAR (276 PSI)	x	x
20	20 BAR (290 PSI)	x	x
21	21 BAR (305 PSI)	x	x
22	22 BAR (319 PSI)	x	x
23	23 BAR (334 PSI)	x	x
24	24 BAR (348 PSI)	x	x
25	25 BAR (363 PSI)	x	x
26	26 BAR (377 PSI)	x	x
27	27 BAR (392 PSI)	x	x
28	28 BAR (406 PSI)	x	x
29	29 BAR (421 PSI)	x	x
30	30 BAR (435 PSI)	x	x
31	31 BAR (450 PSI)	x	x
32	32 BAR (464 PSI)	x	x
33	33 BAR (479 PSI)	x	x
34	34 BAR (493 PSI)	x	x
35	35 BAR (508 PSI)	x	x
36	36 BAR (522 PSI)	x	x
37	37 BAR (537 PSI)	x	x
38	38 BAR (551 PSI)	x	x
39	39 BAR (566 PSI)	x	x
40	40 BAR (580 PSI)	x	x

V - Power/Torque Setting		X1PC	
		60cc	75cc
NN	None	x	x

X - Sensor Group		X1PC	
		60cc	75cc
NN	None	x	x
AA	Single Signal +/- 5V - 2-Pin Deutsch	x	x

Y - Special Hardware		X1PC	
		60cc	75cc
AAA	Roller Element Cradle Bearing	x	x

Z - Paint & Nametag		X1PC	
		60cc	75cc
NNN	PAINT-BLACK, TAG-DANFOSS, FORMAT-A	x	x

Performance X1P-60

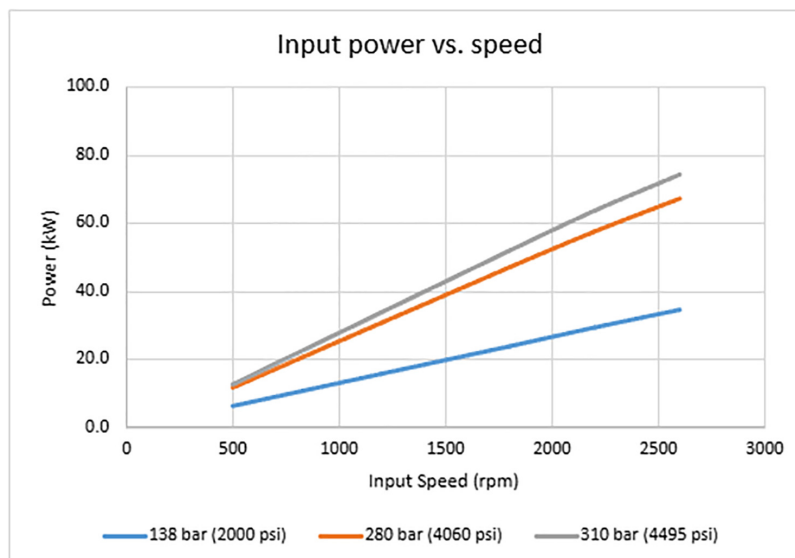
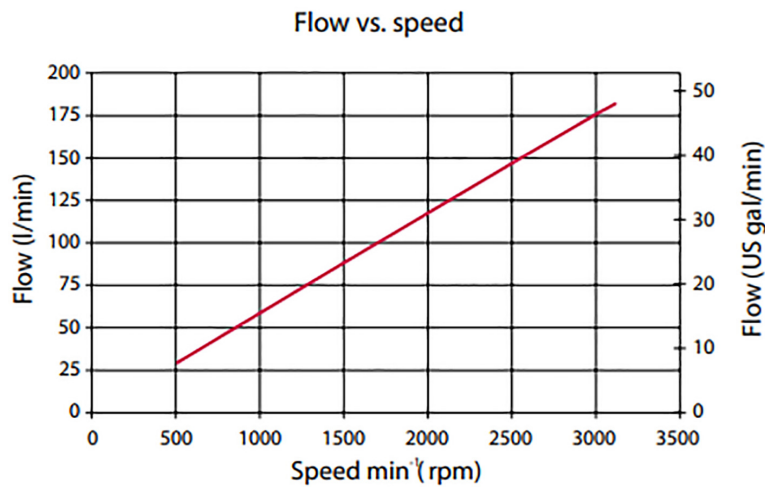

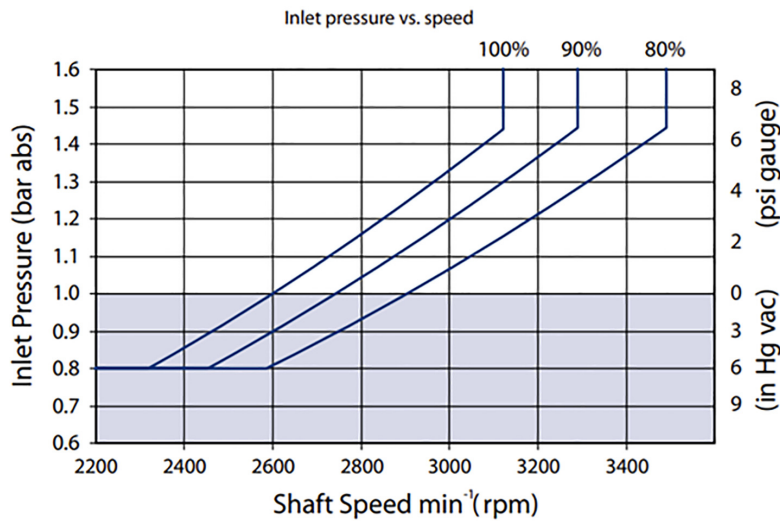
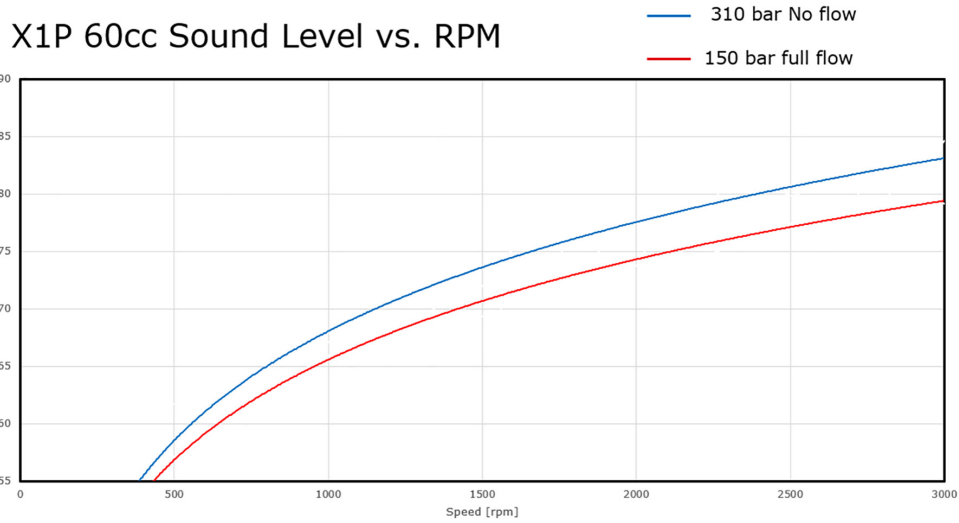
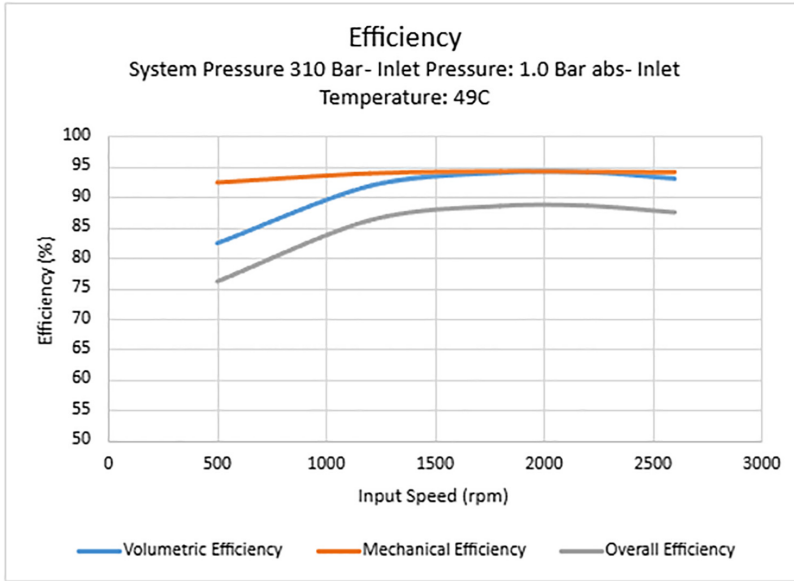

Performance X1PC-75

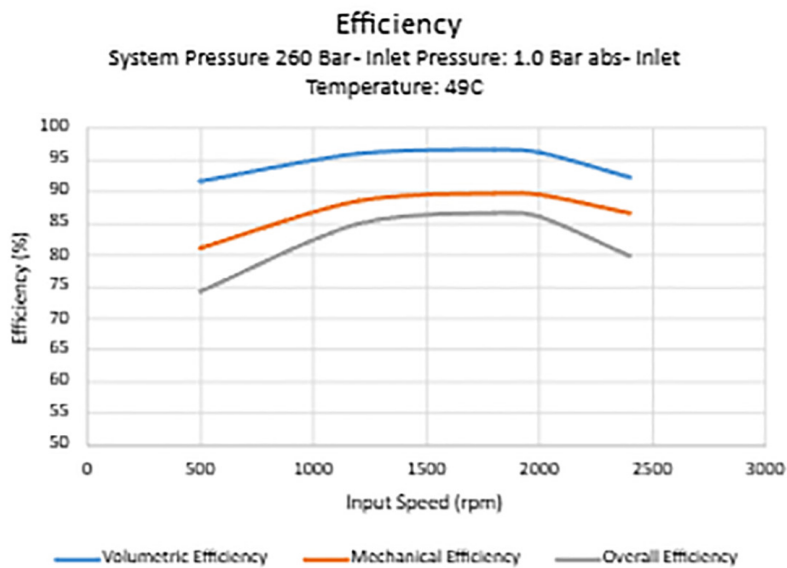
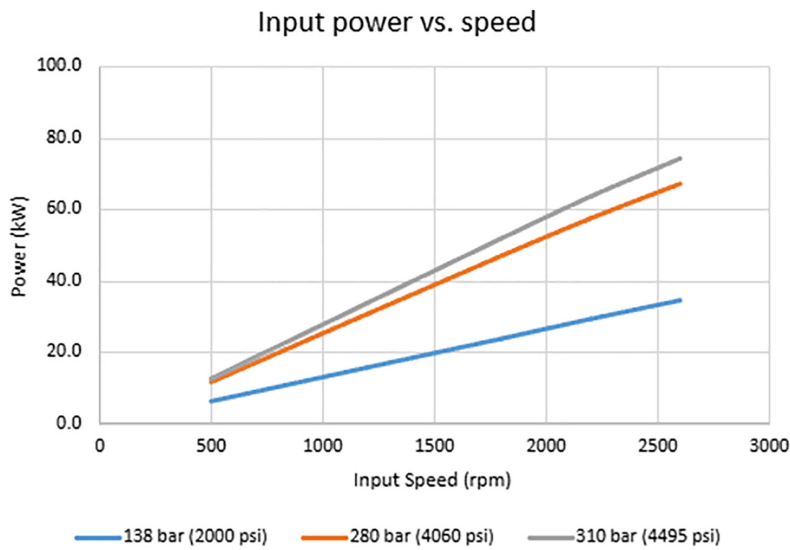
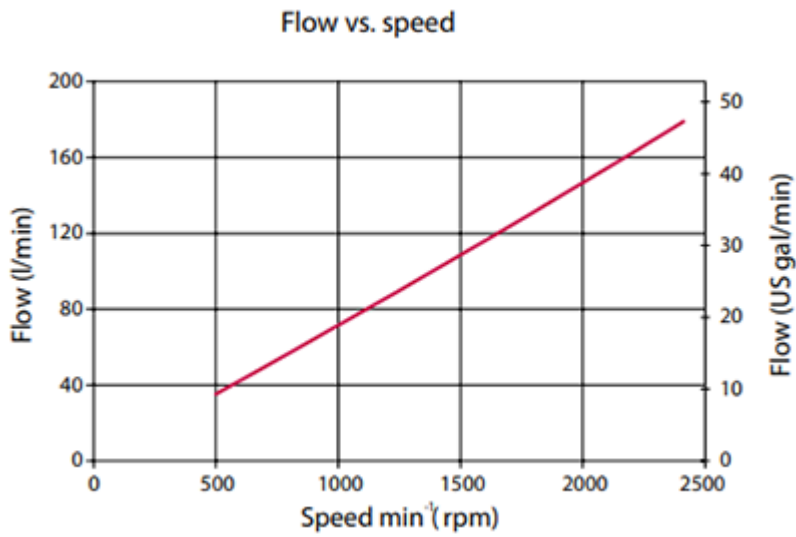

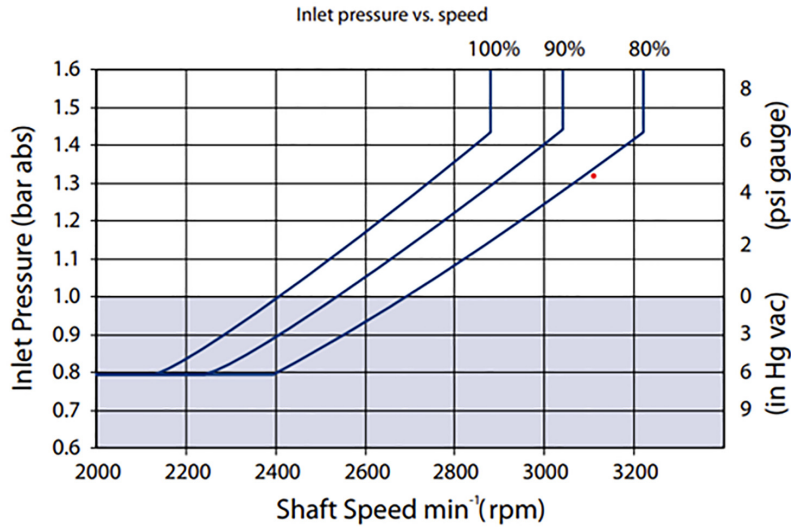

Input shaft

Code	Description	Maximum torque rating ¹ N·m [lbf·in]	
AN,AT	13 Tooth Spline 16/32 Pitch (ANSI B92.1 1970 - Class 6e)	288 [2546]	
BN,BT	14 tooth spline 12/24 pitch (ANSI B92.1B 1996 - Class 6e), No Aux	800 [7080]	

Code	Description	Maximum torque rating ¹ N·m [lbf·in]	
DN,DT	15 Tooth Spline 16/32 Pitch (ANSI B92.1 1970 - Class 6e), No Aux	404 [3575]	<p>15 TOOTH 16/32 PITCH 30° PRESSURE ANGLE 23.813 [0.938] PITCH DIA FILLET ROOT SIDE FIT COMPATIBLE WITH ANSI B92.1B-1996 CLASS 6e ALSO MATES WITH FLAT ROOT SIDE FIT</p> <p>Ø21.96 MAX [0.864]</p> <p>Ø25.27±0.13 [0.995 ±0.005]</p> <p>22.36 ±0.5 [0.88 ±0.02]</p> <p>38.0 ± 0.43 [1.50 ± 0.017]</p> <p>8± 0.8 [0.31 ±0.03]</p> <p>COUPLING MUST NOT PROTRUDE BEYOND THIS POINT</p> <p>P104225</p>
DC	15 Tooth Spline 16/32 Pitch (ANSI B92.1 1970 - Class 6e) 9 Tooth 16/32 Aux Shaft End - Integral Aux Pad	404 [3575]	<p>15 TOOTH 16/32 PITCH 30° PRESSURE ANGLE 23.813 [0.938] PITCH DIA FILLET ROOT SIDE FIT COMPATIBLE WITH ANSI B92.1B-1996 CLASS 6e ALSO MATES WITH FLAT ROOT SIDE FIT</p> <p>Ø21.96 MAX [0.864]</p> <p>Ø25.27±0.13 [0.995 ±0.005]</p> <p>22.36 ±0.5 [0.88 ±0.02]</p> <p>38.0 ± 0.43 [1.50 ± 0.017]</p> <p>8± 0.8 [0.31 ±0.03]</p> <p>COUPLING MUST NOT PROTRUDE BEYOND THIS POINT</p> <p>P104225</p>

Installation drawings

Standard Radial ported endcap (non-optimized)

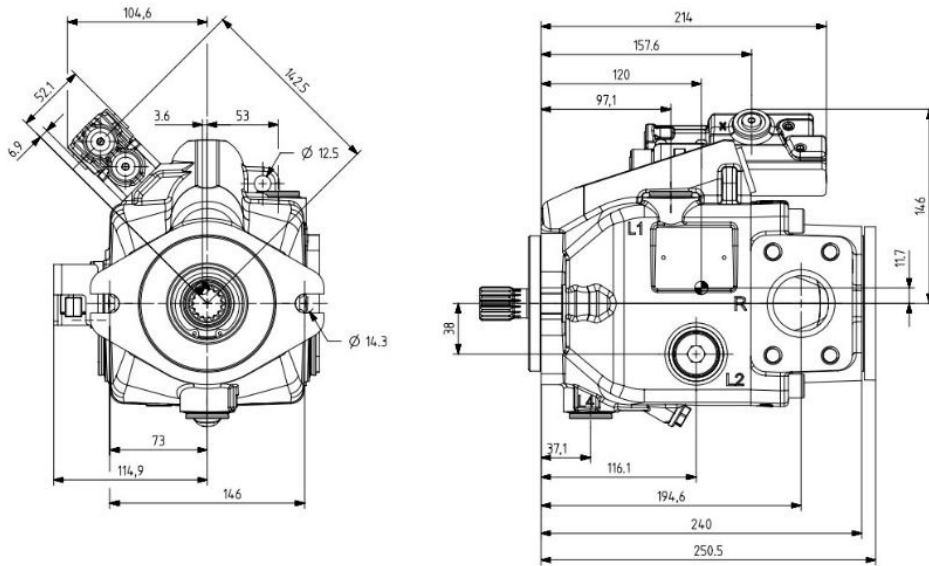

Displacement limiters

X1P-C Frame open circuit pumps are available with an optional adjustable displacement limiter. These adjustable stops limit the pump's maximum displacement and/or minimum displacement. Use the table below to assist with maximum displacement limiting. Minimum displacement per turn will vary based on the application it is in. Please use the service manual to assist with these adjustments.

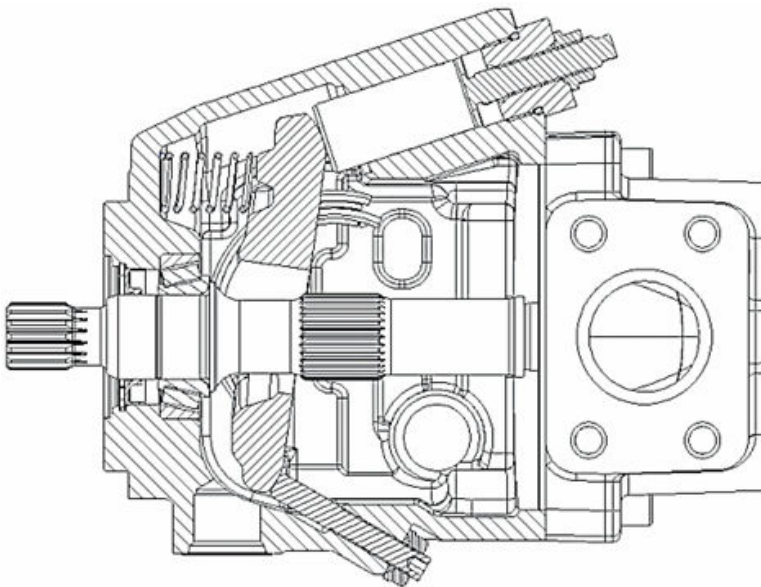

Displacement per turn	
60cc	5.3 cc/rev [0.32 in ³]
75cc	6.3 cc/rev [0.38 in ³]



Hydro-Gear

www.hydro-gear.com

Daikin-Sauer-Danfoss

www.daikin-sauer-danfoss.com

Explore our solutions at danfoss.com.

Additional product literature is available at powersource.danfoss.com.

**Danfoss
Power Solutions (US) Company**
2800 East 13th Street
Ames, IA 50010, USA
Phone: +1 515 239 6000

**Danfoss
Power Solutions GmbH & Co. OHG**
Krokamp 35
D-24539 Neumünster, Germany
Phone: +49 4321 871 0

**Danfoss
Power Solutions ApS**
Nordborgvej 81
DK-6430 Nordborg, Denmark
Phone: +45 7488 2222

**Danfoss
Power Solutions Trading
(Shanghai) Co., Ltd.**
Building #22, No. 1000 Jin Hai Rd
Jin Qiao, Pudong New District
Shanghai, China 201206
Phone: +86 21 2080 6201

Danfoss can accept no responsibility for possible errors in catalogues, brochures and other printed material. Danfoss reserves the right to alter its products without notice. This also applies to products already on order provided that such alterations can be made without subsequent changes being necessary in specifications already agreed. All trademarks in this material are property of the respective companies. Danfoss and the Danfoss logotype are trademarks of Danfoss A/S. All rights reserved.