



Optyma™ iCO2 condensing units

R744 | 50 Hz



1. Important information/Safety.....	4	8. Label	33
2. Product specification.....	5	8.1 CDU CO2 – Optyma™ iCO2 label.....	33
2.1 Delivery product appearance.....	5	8.2 Compressor label.....	33
2.2 PID (Piping & Instrumentation Diagram).....	12	9. MMIDLS specification.....	34
2.4 Pressure resistance.....	13	9.1 MMIDLS product description.....	34
2.5 Strength.....	13	9.2 Survey of functions.....	35
2.6 Electric safety tests (according EN60335-1:2010)	13	9.3 Alarm indications and Status messages	38
3. Component list	14	9.5 Parameters of MMIDLS	39
3.1 Parts name and specification.....	14	10. Controller working procedure.....	40
3.2 Electric diagram	17	10.1 State transition diagram.....	40
4. Connectivity overview	20	10.2 Constraint of cycle operation	40
4.1 Layout and characteristics	20	10.3 Control of the cycle operation	41
4.2 Optyma™ iCO2 Gateway – interface description	20	10.4 Normal operation	42
4.3 Controller version.....	21	10.5 Compressor OFF/ON.....	45
5. Packaging information	22	10.6 Oil return.....	47
5.1 Unpacking.....	22	10.7 Normal mode / Night mode	47
5.2 Disposal Instruction.....	22	10.8 Vacuum mode	48
6. Installation	23	10.9 Fan speed management:	48
6.1 Service and safety advice	23	10.10 Pressure management in case of abnormal pressure rising.....	48
6.2 Location & fixings.....	23	10.11 Error code	49
6.3 Power supply connection.....	24	11. Troubleshooting analysis: diagnosis for error codes.....	50
6.4 Power supply protection	24	12. Appendix material.....	68
6.5 Signal connection	24		
6.6 Protection and features.....	24		
6.7 Electrical protection standard	24		
6.8 EMC compliance	24		
6.9 Warning when touching unit when OFF.....	25		
6.10 System design recommendation.....	25		
6.11 Leak and pressure test	27		
6.12 Oil charge calculation.....	27		
6.13 Oil addition	27		
6.14 Evacuation.....	28		
6.15 Refrigerant charge calculation.....	29		
6.16 Refrigerant charge method.....	30		
6.17 Check before start	31		
6.18 inspection before maintenance	31		
6.19 Gas cooler maintenance.....	31		
7. Transportation, handling and storage.....	32		
7.1 WARNING.....	32		

Application Guidelines 1. Important information/Safety

Storage temperature range	-25 °C ~ 50 °C
Envelope map	<p>Warranty will be null in case of abnormal operations (Out of temperature ranges, bad installation, etc).</p> <p>Note For ambient temperature below the evaporating temperature, condensing unit performances are more sensitive to adverse conditions like strong wind.</p>
Operation humidity range	MAX 95%RH
Power	<p>Rated voltage: Single phase 230V±10% Rated frequency: 50Hz Neutral connection : Yes</p> <p>Note Compressor of Optyma™ ICO2 is equipped with a IPM (Interior Permanent Magnet) motor and built in Frequency converter in the condensing unit. The compressor cannot operate without Danfoss dedicated frequency converter. It will be destroyed immediately if connected directly to public network. The applied frequency from the inverter will be 73,3 Hz for 36,66 rps (2200 rpm) up to 228 Hz for 114 rps (6840 rpm).</p> <p>Compressor speed Min Max rps 36.66 to 114 rpm 2200 to 6840 230V 1N ~50Hz through inverter</p>
Dedicated Application	This CO2 condensing unit is designed to ensure and maintain food for commercial refrigeration and is well tunned for Display Cabinets and Cold Rooms (Fruit Storage, Flower Conservation, Retail stores)
Current	MCC is 15A. For over-current protection we recommend fuse rated 16 A to 20 A
IP protection level	54
RCD type	Type A or B
Levelness	Side to side : Less than or equal 2 degrees Ensure a foundation with horizontal surface (less than 2 degrees slope), strong and stable enough to carry the entire unit weight and to eliminate vibration and interference.
Cooling cap. and thermal load	Max. thermal load should be below max cooling capacity at highest expected ambient temperature. Minimum thermal load should be not too low compared to min cooling cap to avoid cycling.
Evaporator volume	Maximum 3 or 4 evaporator volume between 2 – 6 Liters are OK for Tevap -20 ... +10°C Evaporator volume up to 10 Liters are OK if Tevap ≤ -5°C Evaporator volume below 2 Liters can give some instability of the system: too big variation of pressure and mass flow, CDU controller could not be fast enough to adapt to the dynamic of the evaporator.
Piping, evaporator elevation / CDU	Liquid line length should be maximum 20 meters one way (liquid) (and max charge 4.3 kg) Difference of elevation between CDU and evaporator should be max ±5 m Liquid line PS = 80 bar, refrigerant speed limits: Liquid: from 0.6 to 1.2 m/s Vapor: from 8 to 12 m/s Suction line and evaporator PS should be min 60 bar and preferably 80 bar (fully insulated 19 mm)
Ambient temperature	Min ambient temperature = -20°C Max ambient temperature = +46°C (ECU version 002) Take into account local area temperature. They can be significantly different from average.

2.1 Delivery product appearance

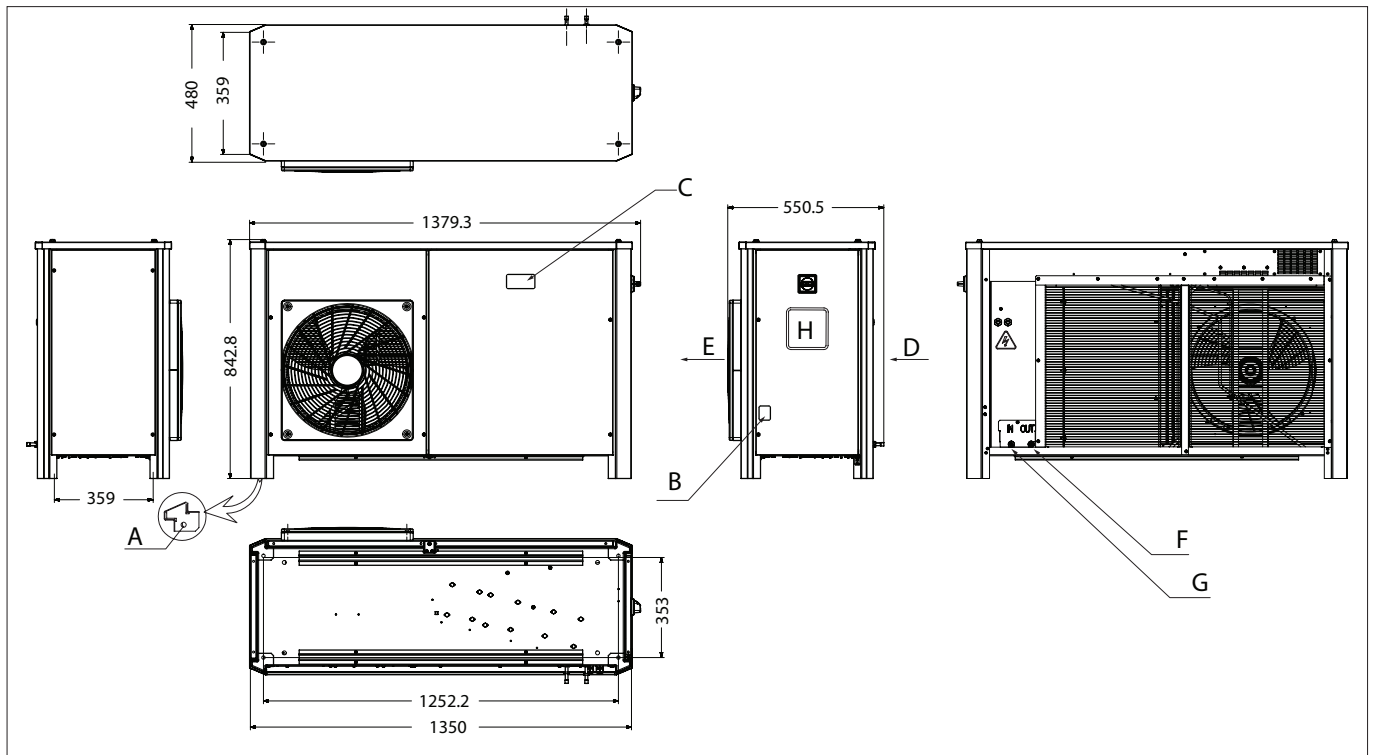

- A Ø12 Hole for Mounting
- B Sight Glass
- C Controller Display
- D Air in

- E Air out
- F Liquid Port
- G Suction Port
- H Nameplate

⚠ Electrical Cables

Note: all dimension are in mm

Application Guidelines 2. Product specification

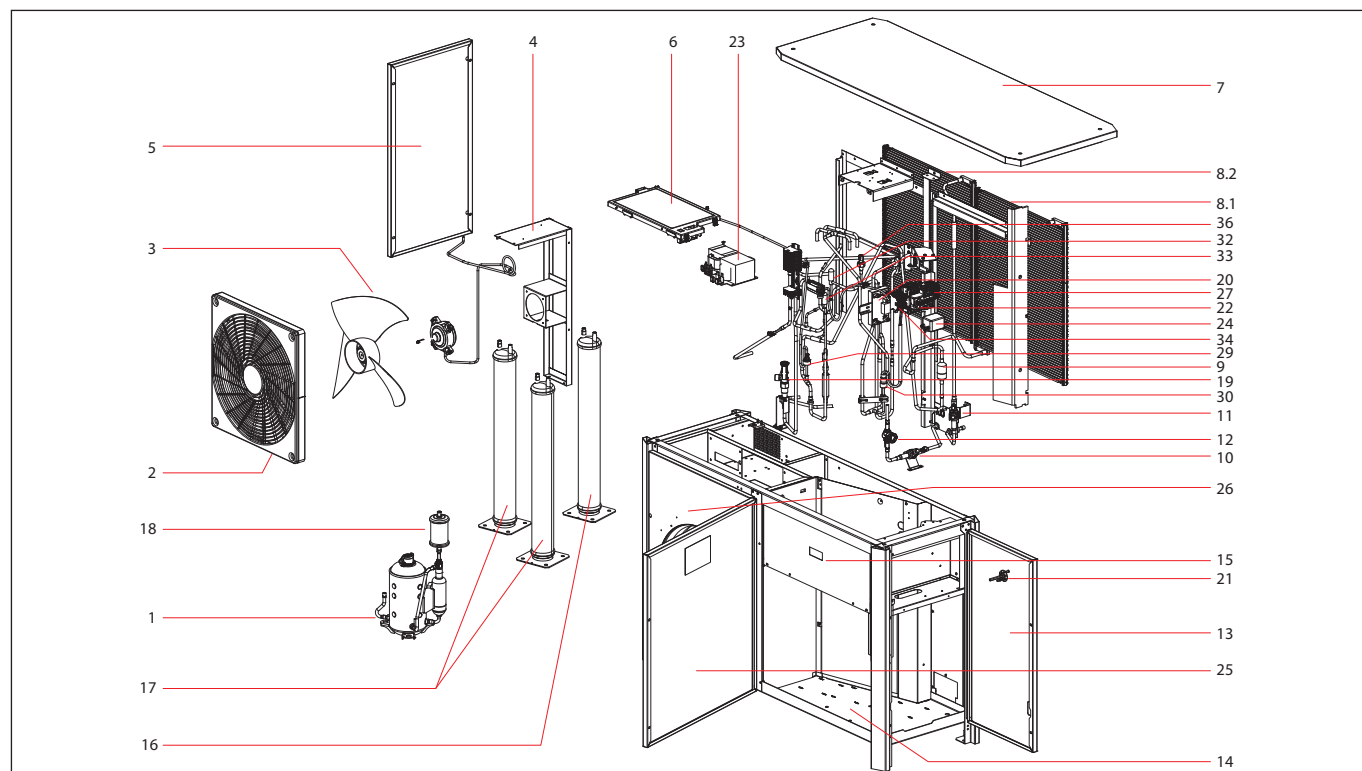

Nr	Component type legend	Component code	SAP Description
1	Compressor	118U4105	SPARE PART, COMPRESSOR 045CC
2	Fan cowl/grill	118U4100	SPARE PART, FAN GRILL D1
3	Fan assembly	118U4129	SPARE PART, FAN ASSEMBLY (D 415)
4	Braket	No spare part	Fan braket
5	Sheet metal left	118U4099	SPARE PART, LEFT SIDE D1
6	Electronic controller	118U4126	SPARE PART, CONTROLLER D1
7	Sheet metal top	118U4101	SPART PART, TOP PANEL D1
8.1	Gascooler 1	118U4112	SPARE PART, FIRST GAS COOLER D1
8.2	Gascooler 2	118U4116	SPARE PART, SECOND GAS COOLER D1
9	Strainer	No spare part	suction strainer
10, 11	Shut-off ball valve, GBCH 10s	009L7582	GBCH 10s CO2 90bar Ball Valve M/25 w AP
12	Sight glass	118U4111	SPARE PART, SIGHT GLASS
13	Sheet metal service panel	118U4097	SPARE PART, RIGHT DOOR D1
14	frame	No spare part	Unit frame
15	Display	080G0233	MMILDS Elect.Control Panel I/25
16	Accumulator	118U4104	SPARE PART, ACCUMULATOR
17	Receiver	118U4103	SPARE PART, RECEIVERS 2X2,5L
18	Filter drier	023Z8409	Filter drier DMT 0835 I/12
19	Pressure relief valve	118U4106	SPARE PART, RELIEF VALVE 80B (15.6 MM2)
20	Gateway	118U4119	SPARE PART, GATEWAY D1
21	Main Switch Handle	118U3858	HANDLE, ABB-OHB2AJM,MSMN,OXSSX131
22	Main Switch Ms132 16-20 A	118U3854	MPCB, ABB-MS132-20+HK1-12
23	Reactor	118U4124	SPARE PART,REACTOR(BIG) (VFD,DRIVE)
23	Reactor 2	118U4125	SPARE PART,REACTOR (SMALL) (VFD,DRIVE)
24	EMC filter (Controller)	118U4120	SPARE PART, NOSIE FILTER (TYPE:EMI FILTE
25	Sheet metal front	118U5273	SPARE PART, FRONT DOOR D1
26	Sheet metal fan	118U4098	SPARE PART, FAN PANEL D1
27	Contactator 16A	118U3847	CONT, ABB-A16-30-01-80+CA5-11
28	Valve body	118U4107	SPARE PART, EXP VALVE (3/8")
29	Suction pressure sensor	118U4108	SPARE PART, PRESSURE SENSOR (0-10 MPA RA
30	High-pressure switch	118U4109	SPARE PART, HIGH PR SWITCH (14MPA)
31	Discharge pressure sensor	118U4110	SPARE PART, HIGH PR SENSOR (0-19.6MPA)
32	High pressure valve coil 1	118U4117	SPARE PART, EXP VALVE COIL (3/8")
33	Receiver valve coil 2	118U4118	SPARE PART, EXP VALVE COIL (3/8")
34	Temperature switch	118U4121	SPARE PART, THERMAL SWITCH KIT
35	Temperature switch 2	118U4122	SPARE PART, REACTOR THERMAL KIT
36	Temperature sensor	118U4123	SPARE PART, THERMISTOR KIT

Components

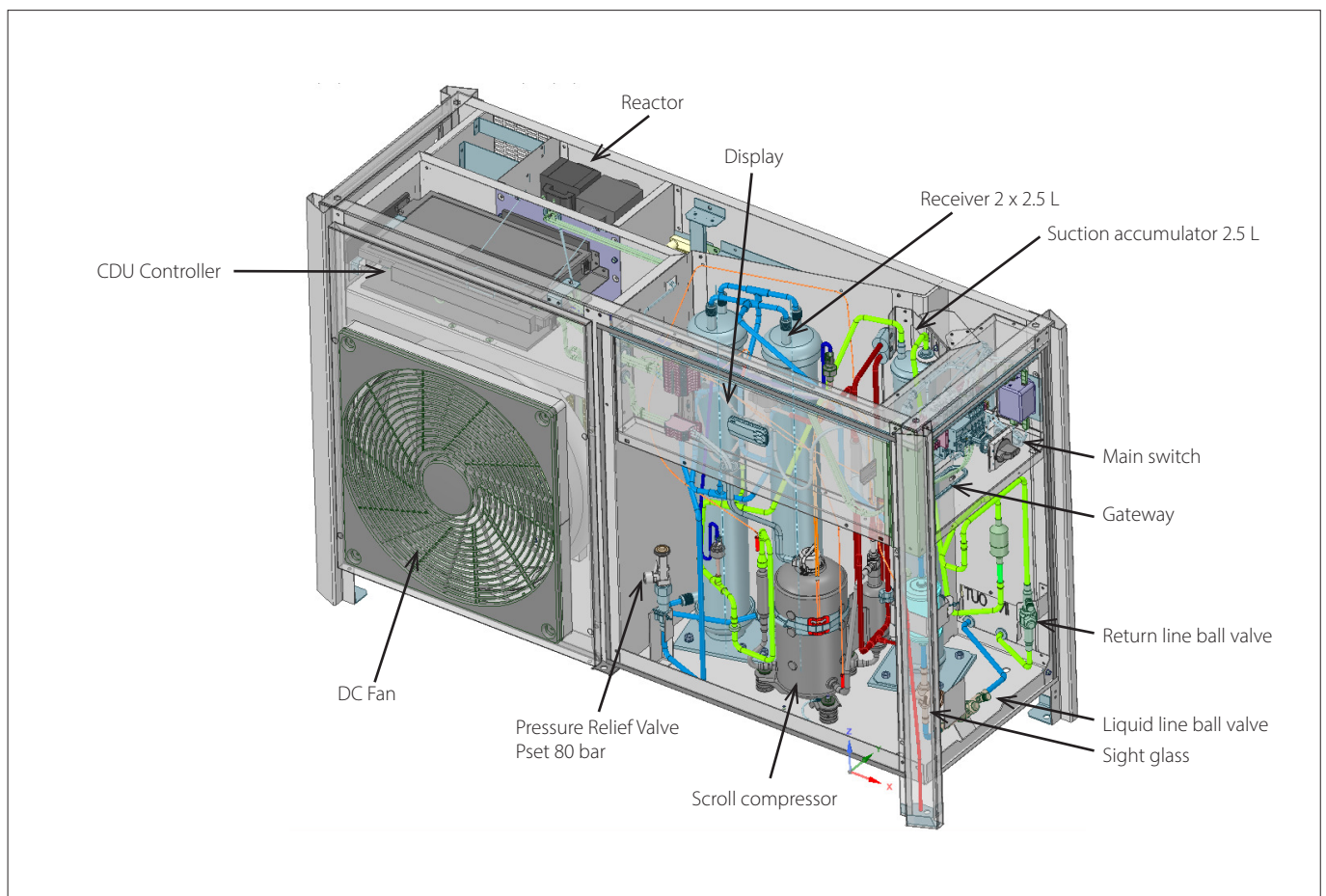
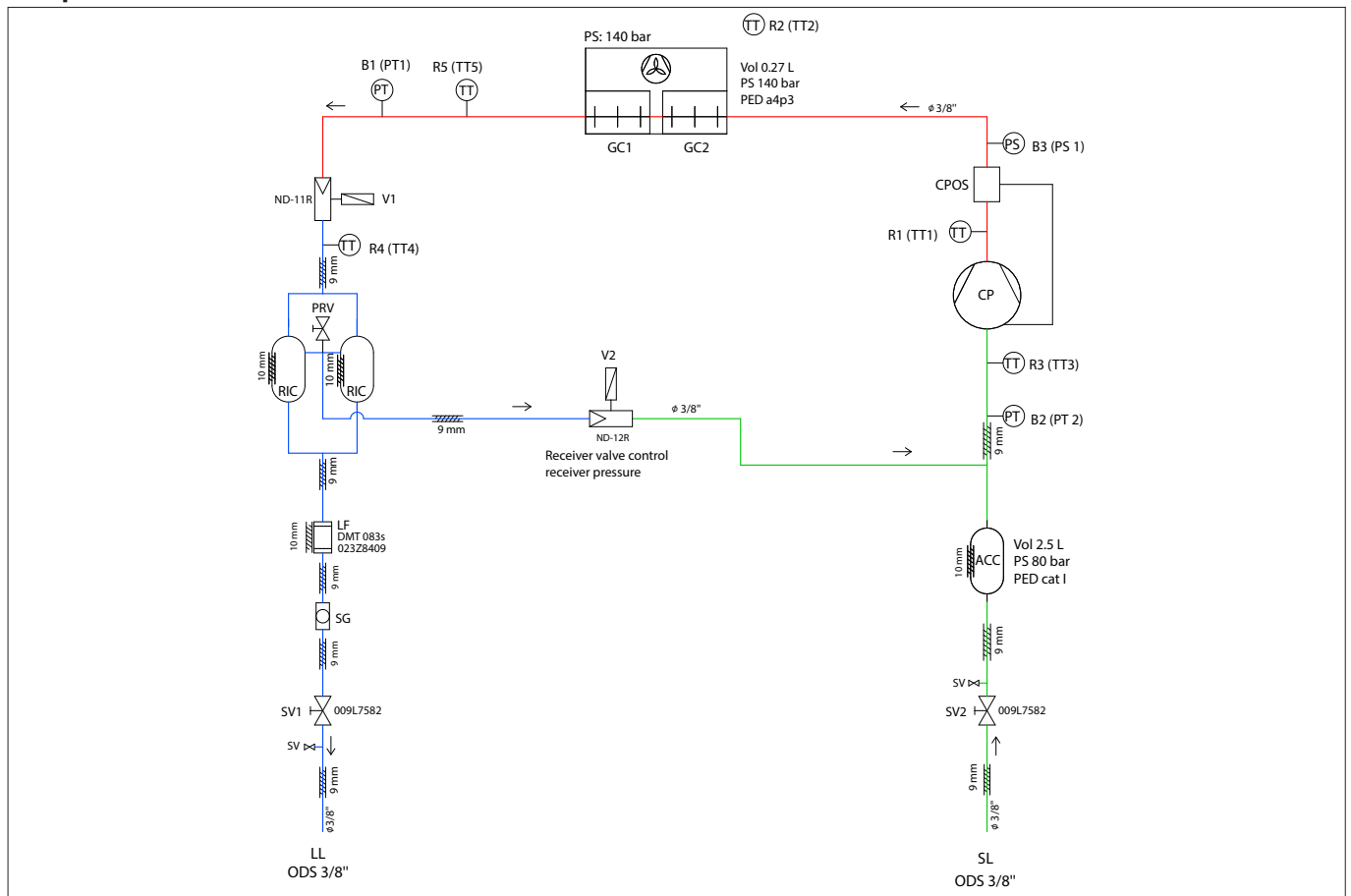

Components

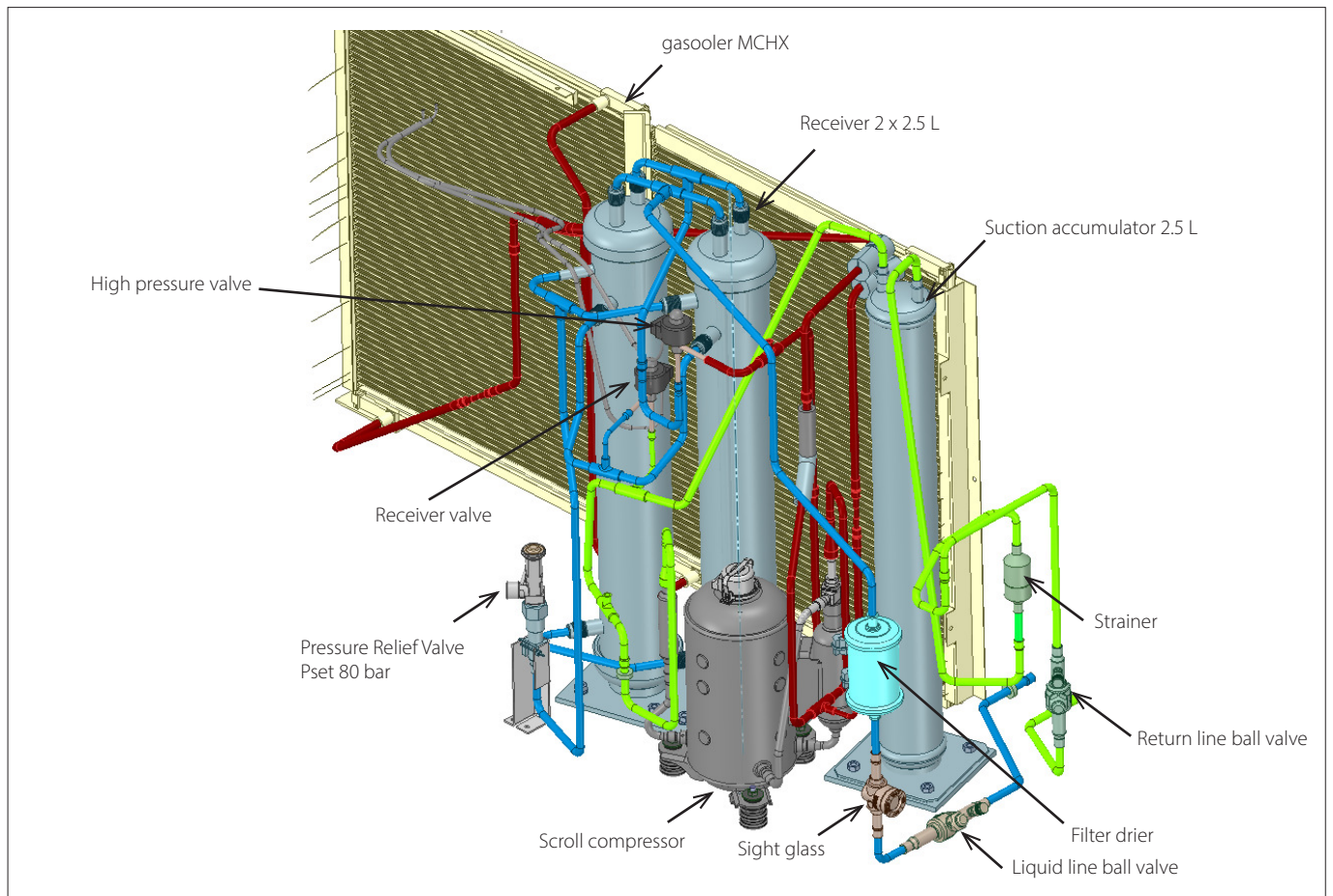
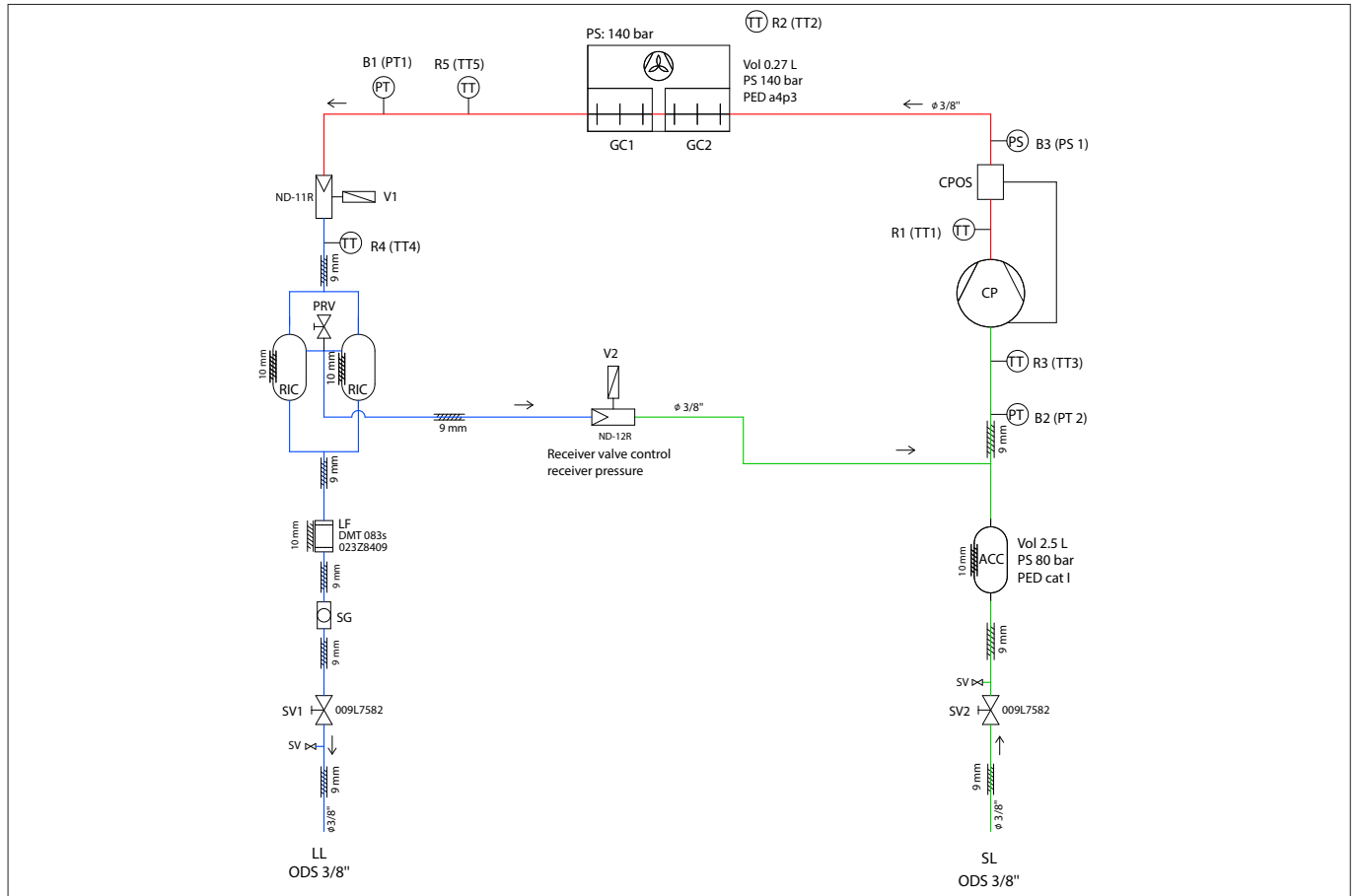

Sensors

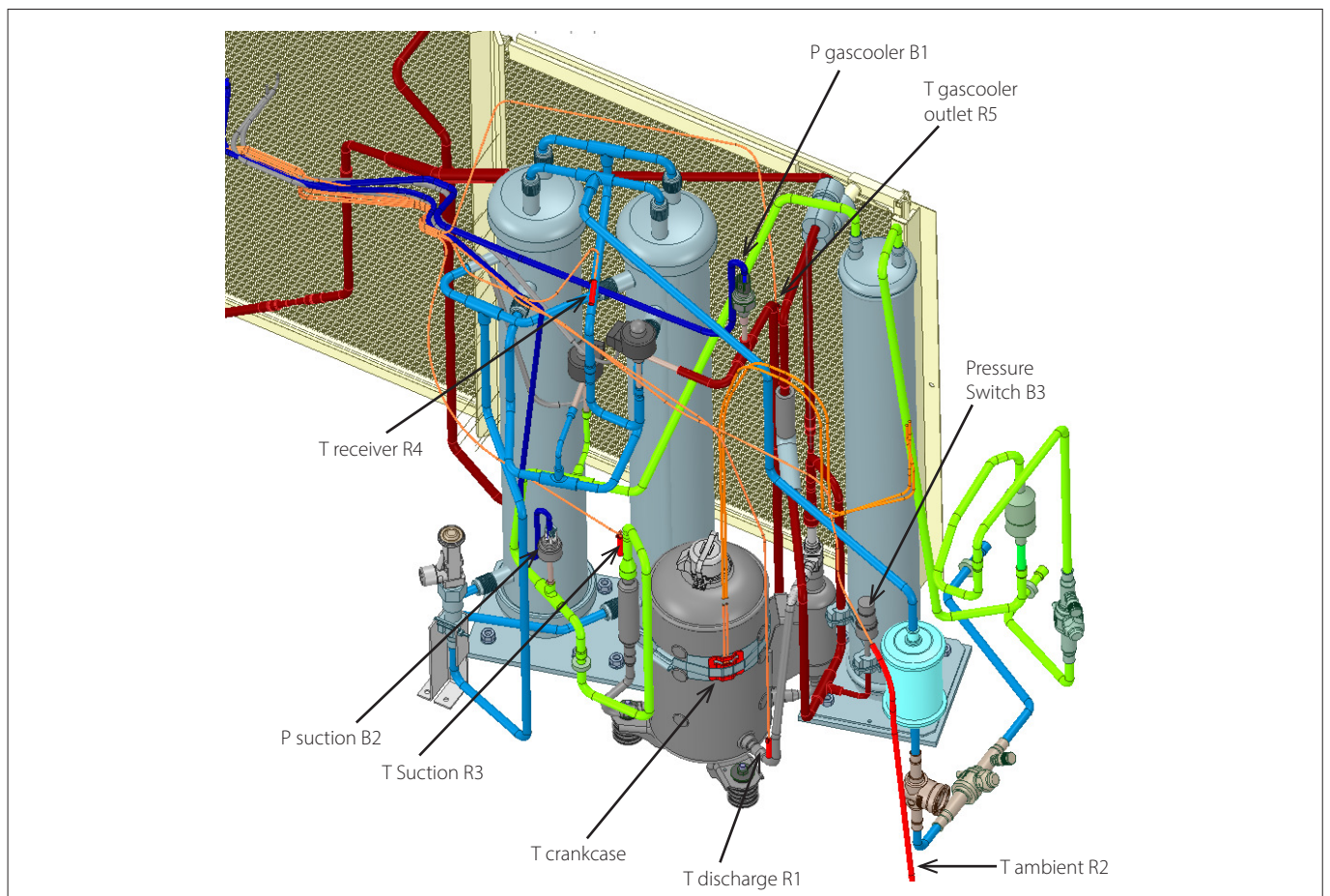
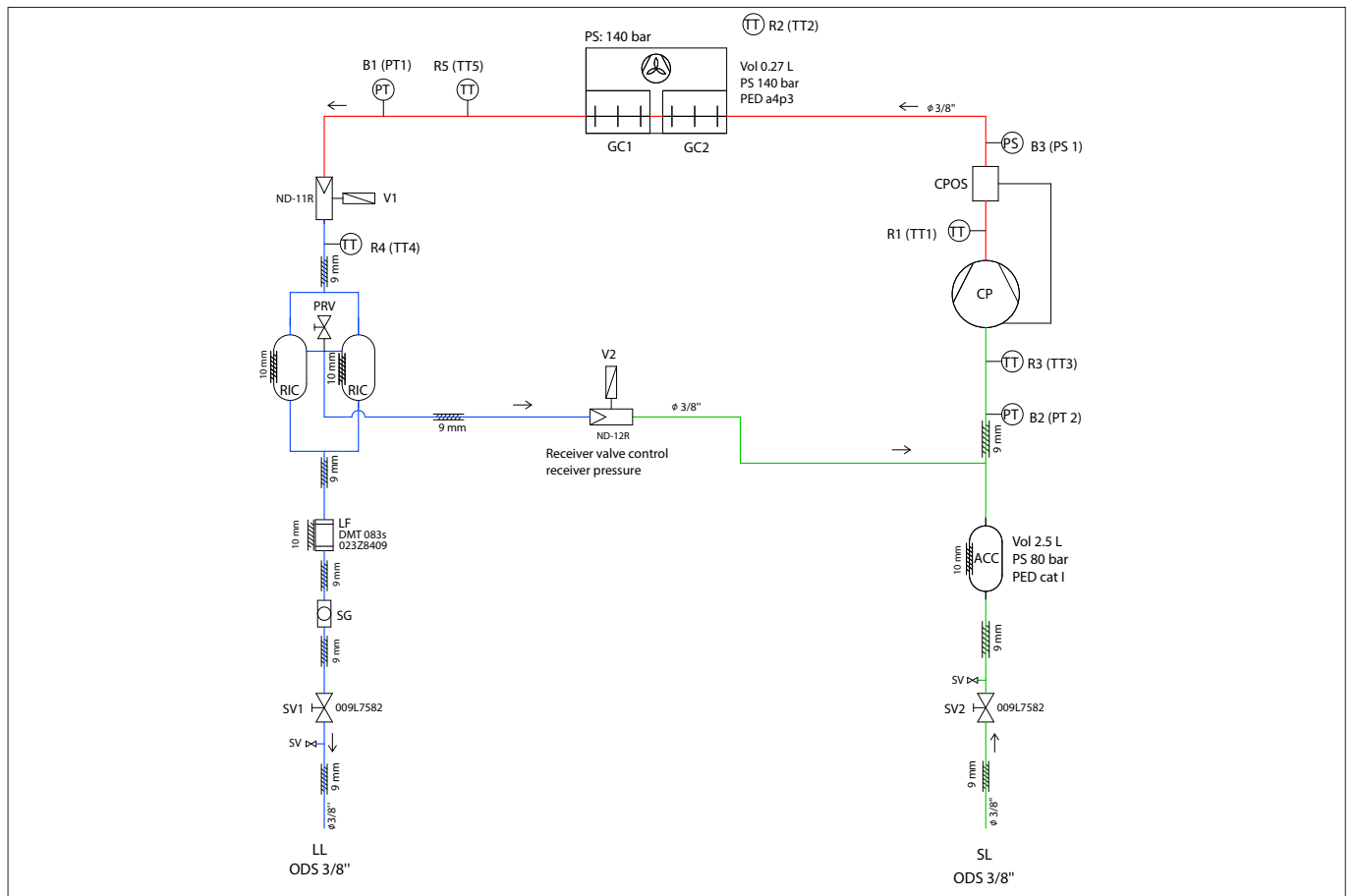

Application Guidelines 2. Product specification

Refrigerant name / amount	CO ₂ Pure grade 99.995% / According to charge calculation excel sheet
Compressor oil	Danfoss oil tank 118U4144 (1 can=250 ml) / 268g±25g PAG ND8 (Factory default) https://assets.danfoss.com/documents/555798/BH543055763390en-000101.pdf
Connecting piping specification	in/out diam 3/8", max working pressure 80 bar
Dimension	H 1028 / W 800 / L 1500 mm
Weight	114 kg (with total charge of oil inside CDU 268 g = 158 g compressor charge + 110 g suction accumulator charge)
Reference standard and regulation	All reference needed for issuing of CE declaration of incorporation for the Optyma™ iCO ₂
Condition1 (rated condition)	Evaporating Temperature : -10 °C
	Ambient Temperature : 32 °C
	Super Heat : 10 K
Cooling capacity	4.58 kW under condition1
Cooling COP / SEPR	1.55 / 3.2 (according to Ecodesign Directive 2009/125/EC, Regulation (EU) 2015/1095) under condition1
Power and sound pressure (standard ISO 3745)	67dB(A) (Sound power level). 35 dB(A) sound pressure at 10 m (free field) under condition 1
Environmental response	<p>Compatible with REACH and RoHS: equipment containing electrical components must not be disposed of together with domestic waste. It must be separately collected with electrical and electronic waste according to local and currently valid legislation.</p> <p>RoHS Directive 2011/65/EU including amendment 2015/863 Though Condensing units are not in the scope of RoHS 2011/65/EU, declaration Danfoss declares that the listed products and spare parts/accessories are compliant with the requirements of the Directive 2011/65/EU of the European Parliament and of the Council of June 8th, 2011. Assessment done according to standard EN IEC 63000:2018. Technical documentation for the assessment of electrical and electronic products with respect to the restriction of hazardous substances.</p> <p>REACH Danfoss supports the objective of REACH (Registration, Evaluation, Authorization and restriction of Chemicals, 1907/2006/EC) to further improve the European Union's chemicals regulatory system, including the aim to advance public health and safety as well as the protection of the environment.</p>

2.2 PID (Piping & Instrumentation Diagram)

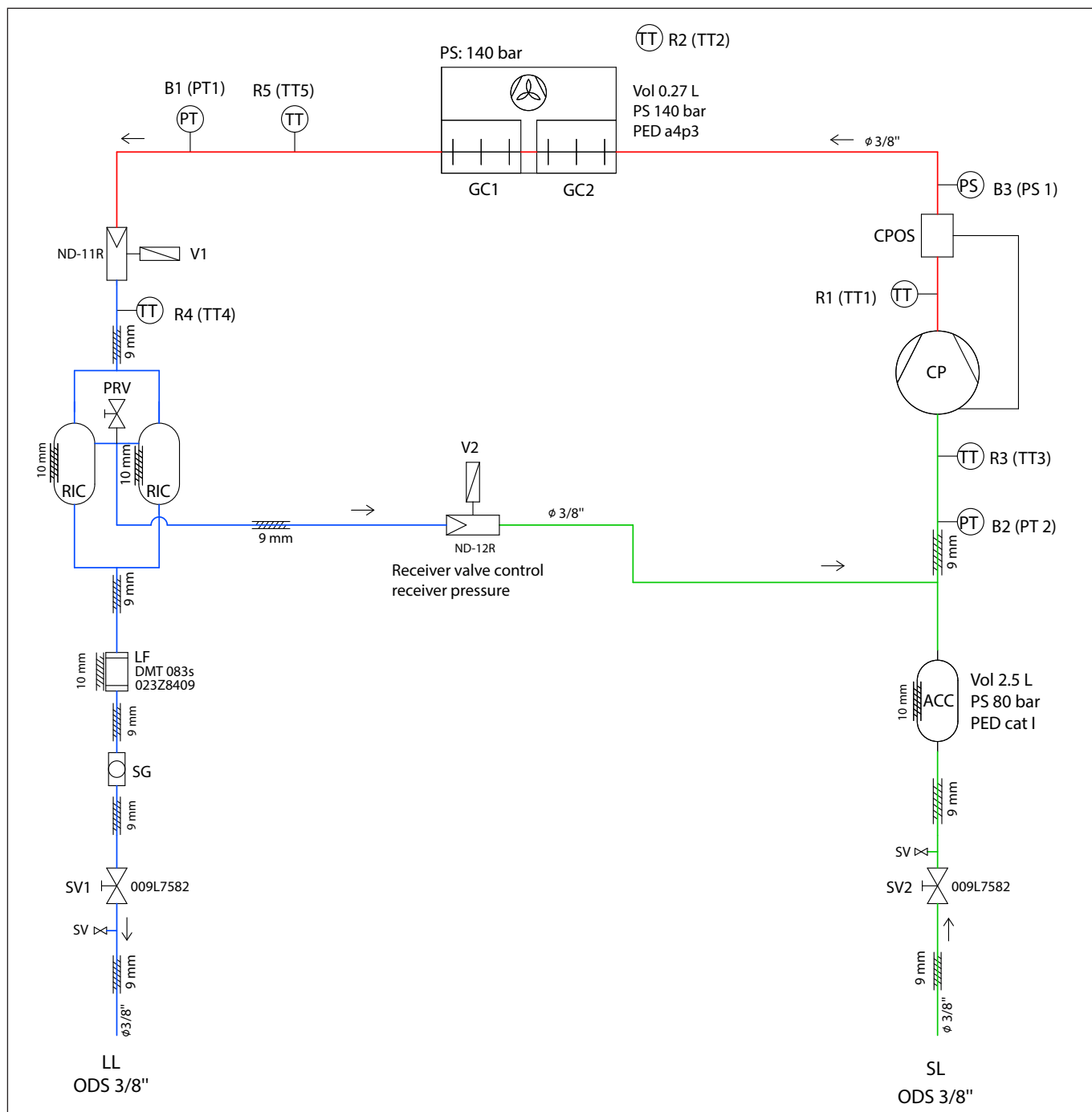

- ACC** - Suction accumulator vol 2.5L PS 80 bar PED cat 1
- B1** - High pressure sensor
- B2** - Low pressure sensor
- B3** - High pressure switch
- CP** - Inverter driven Scroll compressor with oil separator, Compressor suction vol 1.2L PS 80 PED cat 1
- CPOS** - Oil separator build on compressor
- R1** - Discharge temperature sensor
- R2** - Ambient temperature sensor
- R3** - Suction temperature sensor
- R4** - Receiver inlet temperature sensor

- R5** - Gas cooler outlet temperature sensor
- V1** - Expansion valve (main)
High pressure valve control gascooler pressure
- V2** - Expansion valve (gas by-pass)
Receiver valve control receiver pressure
- PRV** - Pressure Relief valve
- GC1** - MCHE Gas cooler 1
- GC2** - MCHE Gas cooler 2
- LF** - Liquid filter dryer
- LL** - Liquid line
- PRV** - Pressure relief valve on receiver Pset = 80 bar

- RIC** - Receiver Vol 2.5 L PS 80 bar PED cat I
 - SG** - Sight glass with moisture indicator
 - SL** - Suction line
 - SV** - Schrader valve
 - SV1** - GBCH Service ball valve 1 (liquid line)
 - SV2** - GBCH Service ball valve 2 (suction line)
- Red line** - high pressure line
Blue line - Liquid line
Green line - Suction line
Black line - Oil line

2.4 Pressure resistance

Max. working pressure	High pressure side 140 bar Medium pressure 80 bar Low pressure side 80 bar PRV (Pressure Release Valve) setting : 80 bar
Test pressure	According to EN378-2





2.5 Strength

Corrosion resistance	Salt spray test 1000 h (According to EN60068-2-52)
-----------------------------	--





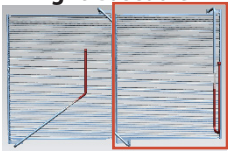
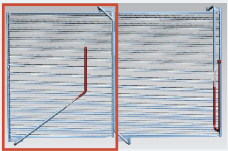
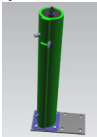
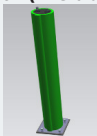

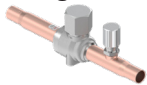
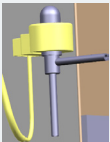

2.6 Electric safety tests (according EN60335-1:2010)

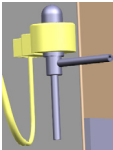
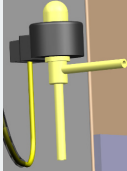
TEST	MAIN FEATURES
Protective Bond Test	25A, 0.1Ω Max time 3 sec.
High Voltage Test	1000V, 1sec. Max current 20mA
Insulation Resistance Test	500V DC Low limit 1MΩ
Leakage Current Test	Max 3.5mA at 1.06 rated voltage

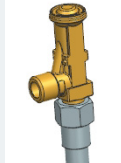





3.1 Parts name and specification

Parts Name	Specification
Kit Compressor (included insulation) 	Spare part code : 118U4105 Rated voltage : DC165V Power voltage : Through Danfoss Optyma™ iCO2 inverter controller (118U4126)
Oil Tank 	Spare part code : 118U4144 Dimension : L60mm x W60mm x H150mm
Right Gascooler 	Spare part code : 118U4112 (Right GC) Type : Aluminum Brazed (external view). Microchannel technology (internal view) Dimension : H480 mm X W572mm X D11.5mm for selection, refer page no 27
Left Gascooler 	Spare part code : 118U4116 (Left GC) Type : Aluminum Brazed (external view). Microchannel technology (internal view) Dimension : H480 mm X W572mm X D11.5mm for selection, refer page no 27
Kit Receiver (included insulation) 	Spare part code : 118U4103 Vessel dimension : Diameter 76mm Height 687mm Volume : 2.5 L each Pipe diameter : 3/8" X 5 pipes
Kit Accumulator (included insulation) 	Spare part code : 118U4104 Vessel dimension : Diameter 76mm Height 687mm Volume : 2.5 L Pipe diameter : 3/8" X 2 pipes
Dryer 	Spare part code : 023Z8409 Manufact. designation : DMT 083s Dimension : Diameter 68.0mm Length 144mm Connection : 3/8" X 2 pipes
Moisture indicator 	Spare part code : 118U4111 Dimension : Length 117 mm Indication : From Yellow (wet) to green (dry) Connection : 3/8" X 2 pipes
Charge Valve 	Spare part code : 009L5582 Manufact. designation : GBC 10s H Manufacturer P/N : 009L5582 Connection : 3/8" X 2 pipes
High pressure valve coil 	Spare part code : 118U4117 Type : ND-11R Rated coil voltage : DC 14 V Rated coil current : 0.3 A (per phase) Rated coil resistance: 46 Ω (at 20°C)

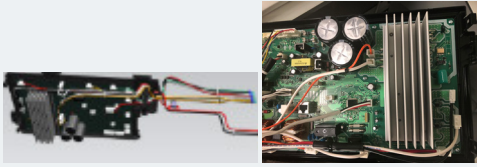
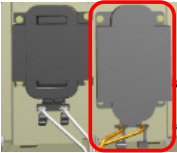
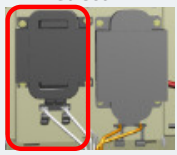
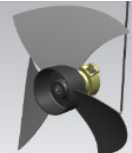
Application Guidelines 3. Component list

Parts Name	Specification
receiver valve valve coil 	Spare part code : 118U4118 Type : ND-12R Rated coil voltage : DC 14 V Rated coil current : 0.3 A (per phase) Coil resistance : 46 Ω (at 20°C)
Spare part valve body for both high pressure valve and receiver valve (3/8") 	Spare part code : 118U4107 Inlet pipe diameter : Φ 6 mm Outlet pipe diameter : Φ 9.5 mm
Temperature sensor assembly 	Spare part code : 118U4123 Resistance : $R_{100} = 184.3 \text{ k}\Omega \pm 3\%$ (Gas cooler refrigerant outlet thermistor, Receiver inlet temperature thermistor, Ambient air thermistor, Suction temperature thermistor) Resistance : $R_{100} = 3.3 \text{ k}\Omega \pm 5\%$ (Discharge temperature thermistor) <i>Press the small terminal clip and remove the upper from the lower part, and connect the new sensor kit the other way around. Ensure that the upper and lower part of the terminal interlocks with a "click".</i>
Relief valve 	Spare part code : 118U4106 Set pressure : 80 bar Over pressure : +10% Blowdown : -15% Connection : INLET 3/8" OUTLET 3/4"
High pressure sensor 	Spare part code : 118U4110 Type : Ratiometric Rated voltage : DC 5 V Measuring range : 0 bar~196 bar Pipe diameter : 6 mm
Low pressure sensor 	Spare part code : 118U4108 Type : Ratiometric Rated voltage : DC 5 V Measuring range : 0 bar~100 bar Pipe diameter : 6 mm
High Pressure switch 	Spare part code : 118U4109 Type : PS80-2X series Actuation pressure : 140 + 0 bar -7 bar Current range : ~1A
Thermal switch (Compressor surface) 	Spare part code : 118U4121 Type : JP72 series Actuation temperature : $125 \pm 5 \text{ }^\circ\text{C}$ Release temperature : $85 \pm 15 \text{ }^\circ\text{C}$ Current range : 5 mA ~ 1.5 A
Thermal switch (Reactor surface) 	Spare part code : 118U4122 Type : JP72 series Actuation temperature : $110 \pm 5 \text{ }^\circ\text{C}$ Release temperature : $70 \pm 15 \text{ }^\circ\text{C}$ Current range : 5 mA ~ 1.5 A

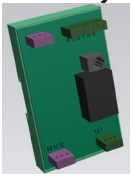
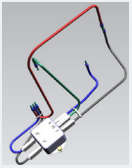
Application Guidelines 3. Component list

Parts Name	Specification
CDU Controller (6) 	Spare part code : 118U4126 Rated voltage : 230 V Rated frequency : 50 Hz Input current : Less than or equal 15 Arms <i>The package includes inverter</i>
Reactor 1 	Spare part code : 118U4124 Type : VFD (Variable Frequency Drive) Rated current : 16 A (There are two Reactor per condensing unit)
Reactor 2 	Spare part code : 118U4125 Type : VFD (Variable Frequency Drive) Rated current : 16 A (There are two Reactor per condensing unit)
Fan motor & blade 	Spare part code : 118U4129 Type : DC brushless motor with built-in sine wave circuit Specifications : Rated voltage DC 240 V Rated current 0.08 A Control power supply volt : DC 15 V Rated rotation speed : 870 rpm
Main switch 	Spare part code : 118U3854 Official designation : KIT MPCB, ABB-MS132-20+HK1-11 Rated voltage : 690 V Rated current : 20 A
Main switch handle 	Spare part code : 118U3858 Type : MSHDLTB Rated current : 20 A
Contactors 	Spare part code : 118U3847 Official designation: KIT MPCB, ABB-A16-30-01-80+CA5-10 Rated voltage : 690 V Rated current : 16 A Design life : ON/OFF 10.000.000 cycle
Gateway 	Spare part code : 118U4119 Official Designation : Gateway Rated voltage : 100 - 277 VAC Rated frequency : 50/60 Hz
EMC filter 	Spare part code : 118U4120 Official designation : EMC filter Type : FN2030B-6-06
Display 	Spare part code : 080G0233 Official designation : Display Type : MMILDS

Please refer to drawing page 6 for Sheet metal parts.

3.2 Electric diagram

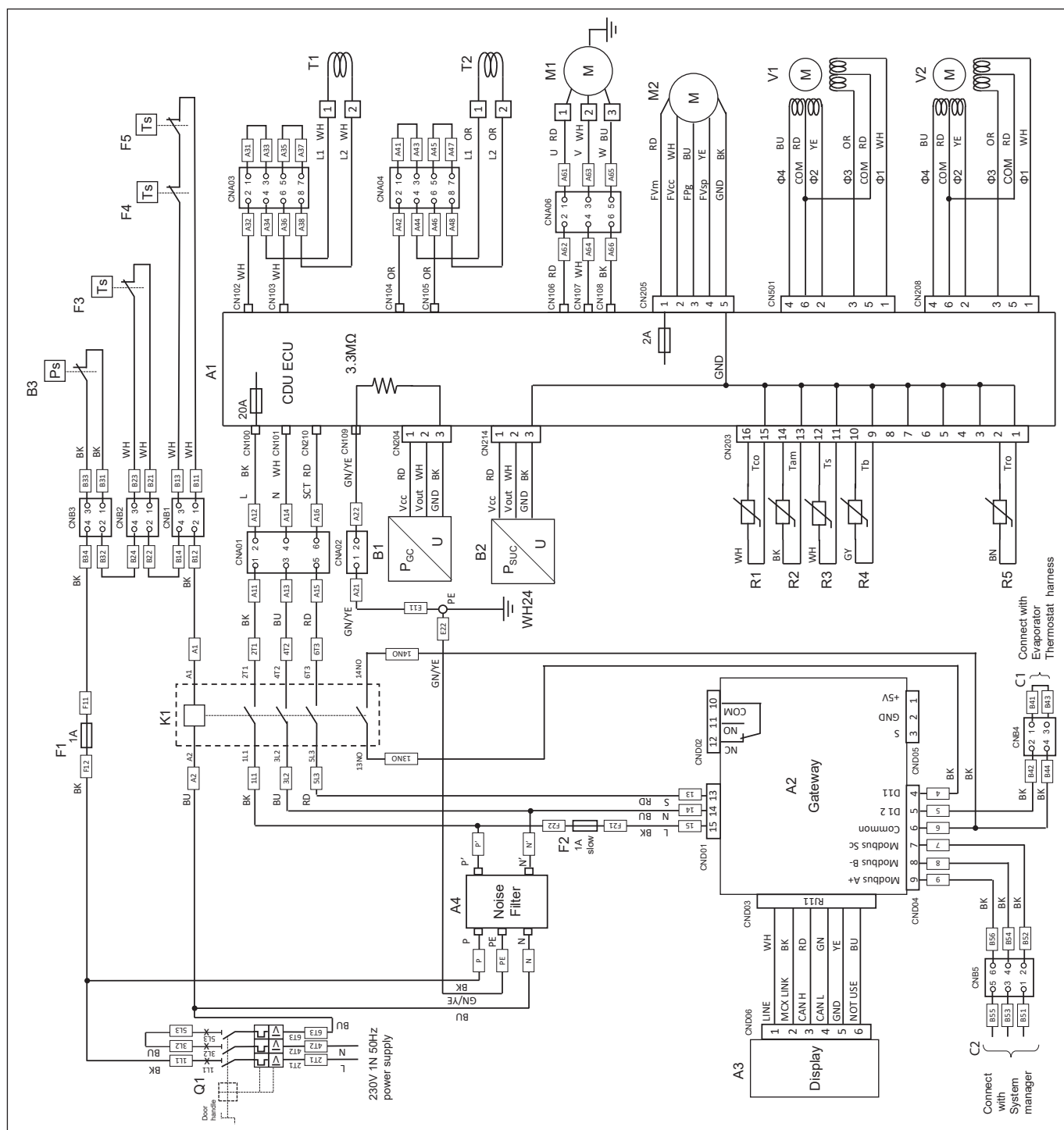

- A1** : CDU ECU
- A2** : CDU Gateway
- A3** : CDU Display
- A4** : Noise filter
- B1** : High pressure sensor
- B2** : Low pressure sensor
- B3** : High pressure switch
- C1** : Connect with Evaporator Thermostat harness
- C2** : Connect with System manager
- F1** : Fuse (Pressure SW Thermal SW circuit)
- F2** : Fuse (GW circuit)
- F3** : Thermal switch (compressor)
- F4** : Thermal switch (reactor1)
- F5** : Thermal switch (reactor2)

- K1** : Contactor
- M1** : Compressor
- M2** : Fan motor
- Q1** : Main switch
- R1** : Discharge temp. thermistor
- R2** : Ambient air temp. thermistor
- R3** : Suction temp. thermistor
- R4** : Receiver inlet temp. thermistor
- R5** : Refrigerant outlet temp. thermistor
- T1** : Reactor1
- T2** : Reactor2
- V1** : Expansion valve (main)
- V2** : Expansion valve (bypass)

- Wire colors**
- BK** : black
 - BU** : blue
 - BN** : brown
 - GN** : green
 - GY** : grey
 - OR** : orange
 - RD** : red
 - YE** : yellow
 - WH** : White

Terminal block layout and wiring plan with tags (1/2)

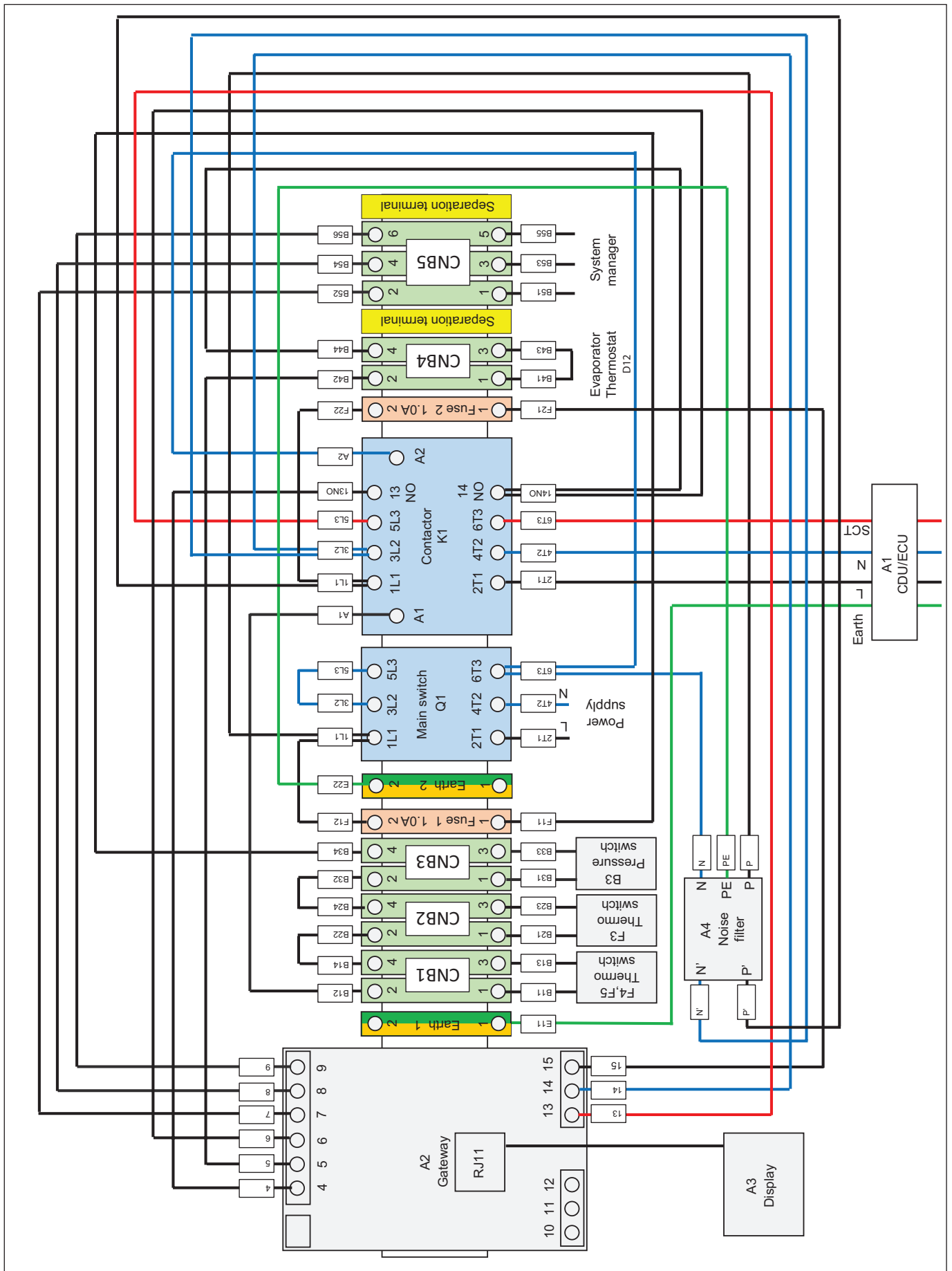

Terminal block layout and wiring plan with tags (2/2)

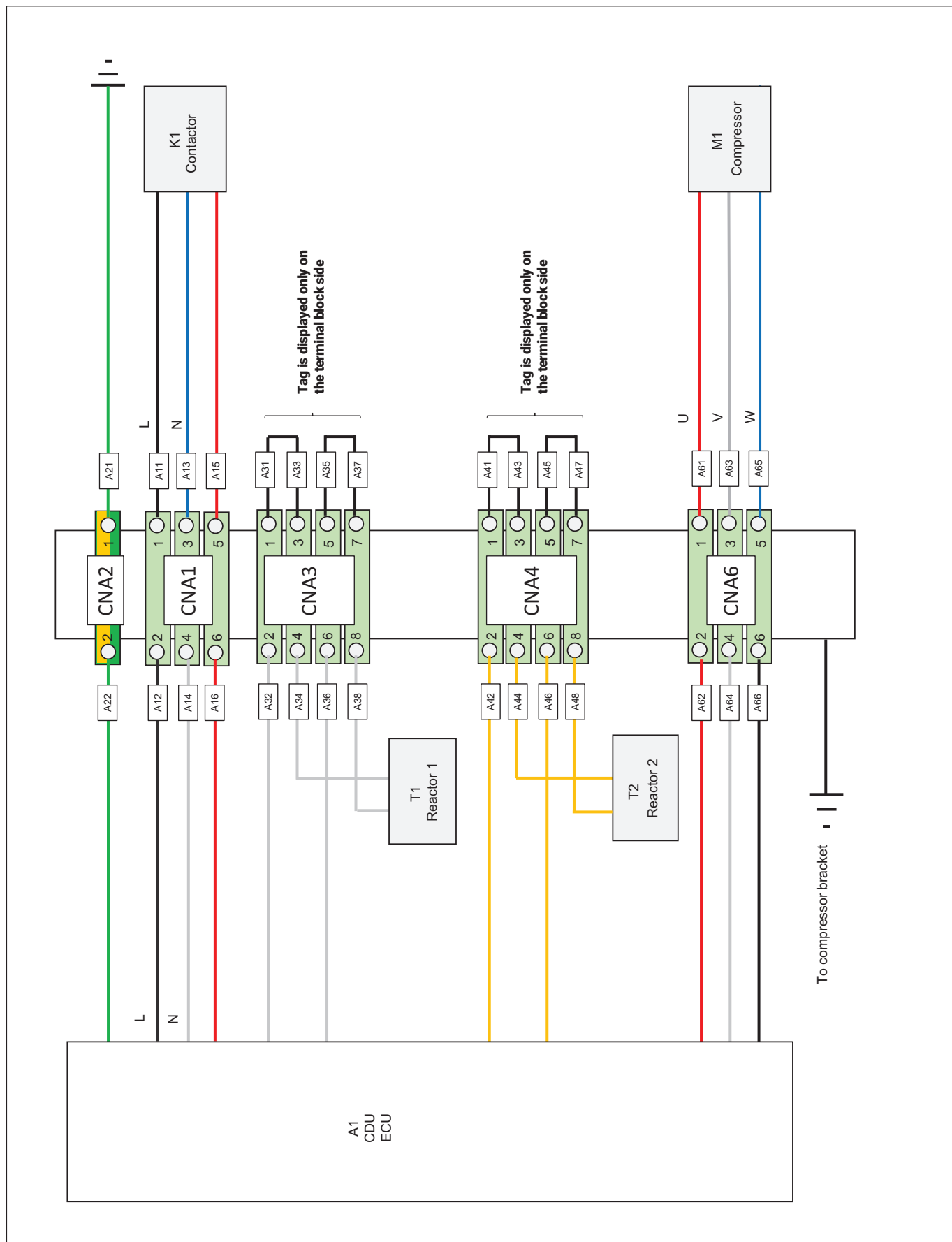

4.1 Layout and characteristics

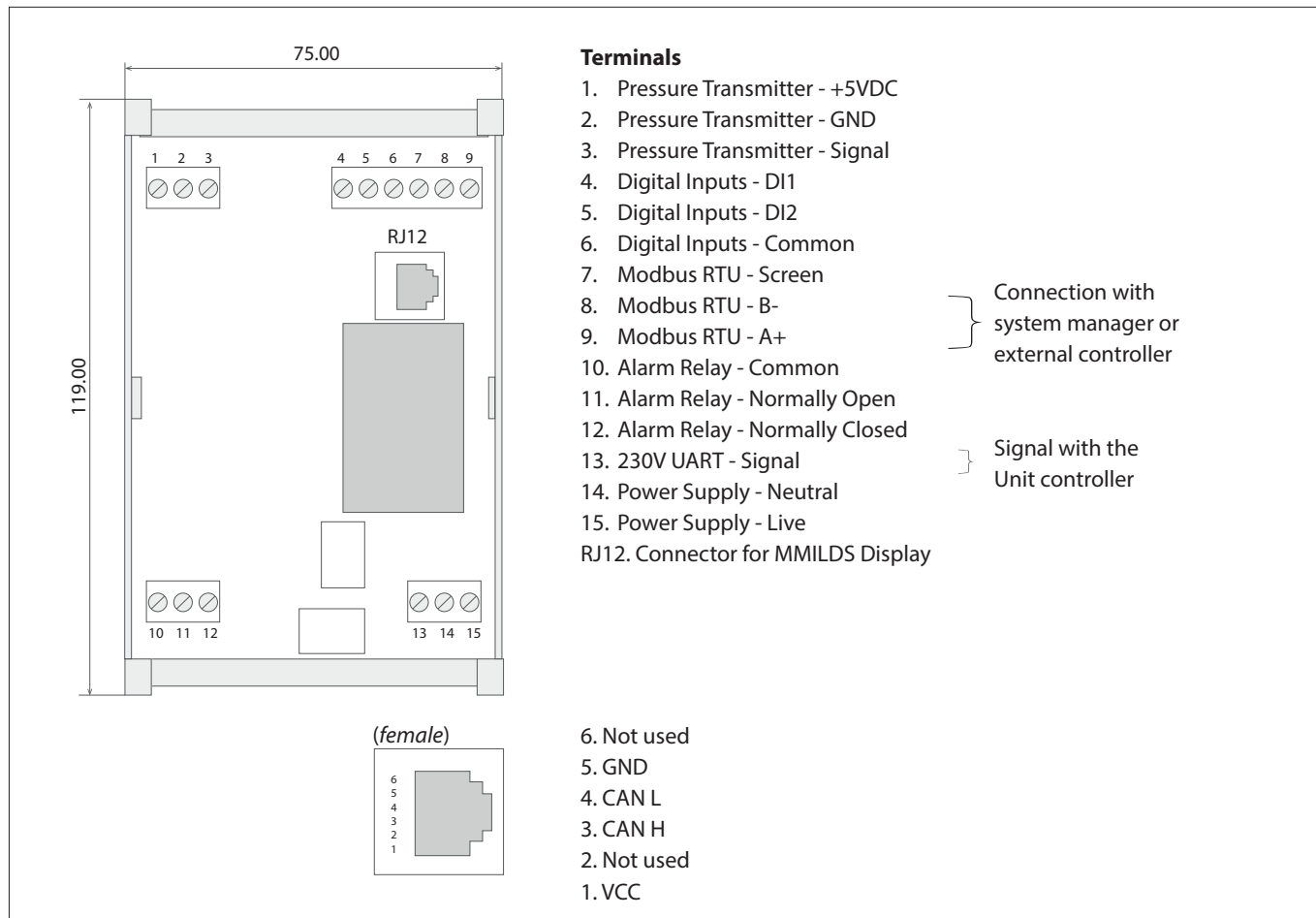

4.2 Optyma™ iCO₂ Gateway – interface description

The iCO₂ condensing unit is equipped with a gateway for communication to external controls:

Physical Specification	
Mounting	DIN-rail
Dimensions	75x119x59 mm
Weight	~150 g
Environment	-30°C to +60°C during operation -40°C to +70°C during transport 20 – 90% Rh, not condensed
Power supply	
Input	100-277VAC, 50/60Hz Max. 8VA
Protection	1A slow-blow fuse
Alarm relay SPDT to connect alarm horns or lights, ext. controllers or control circuits.	
Contact function	SPDT (Single-Pole Double-Throw)
Max. voltage	277 VAC, 30 VDC
Max. current	3 A (resistive load)
Connection	3 screw terminals
Digital Inputs to be used for auxiliary signals, such as an external thermostat.	
Nominal voltage	12 V URGENT: Do NOT apply external voltage, which will damage the controller. Connect ONLY voltage free (dry) relay contacts!
Connection	3 screw terminals

Application Guidelines 4. Connectivity overview

Analog Input to be used with a ratiometric pressure transmitter.	
Nominal voltage	5 VDC
Max. current	30 mA
Connection	3 screw terminals
230V Universal Asynchronous Receiver Transmitter (UART) to communicate with the condensing unit controller	
Cable type:	2,5mm ² / AWG10
Cable length:	Max. 30 m
Transmission system	Super imposed AC power supply system
Transmission waveform	Rectangular wave
Logic	Negative Logic (NRZ signal)
Transmission rate	500 bps ± 1.0%
Synchronization method	Start-stop synchronous half-duplex system
Start bit	Logical 0
Data delivery	LSB First
Parity	Even parity
Stop bit	Logical 1
Character Spacing	In principle, no space is left between the stop bit and the next character, but up to 100 ms is permitted by design.
RS485 Modbus to connect to Danfoss ADAP-KOOL® network or programmable controllers. For more details refer to Danfoss design guide no. RC8AC902 "Data communication between ADAP-KOOL® refrigeration controls".	
Baudrate	19 200 / 38 400 Kbps (automatic selection)
Data bits	8
Stop bits	1
Parity	Even
Termination	A 120 ohm resistor should be mounted if the Gateway ECU is the last node on the bus
Biasing	Biasing resistors (pull-up, pull-down) should typically be built-in in master on the bus
Protocol	Modbus RTU
CAN bus to connect the local display MMILDS. See more details in chapter 9.1ff within this document.	
Baudrate	50 Kbps
Termination	Built-in 120 ohm resistor
Protocol	CANopen
Real-time clock (RTC)	
Backup power	The Gateway ECU is equipped with a real-time clock (RTC) with a capacitor for backup power.
Power reserve	4 hours
Usage	The RTC is designed to be used for day/ night switchover, ect.

4.3 Controller version

Gateway Version (GW)	1.10 (U80 parameter)
Controller software version	002 (o08 parameter)

5.1 Unpacking

When unit reaches your warehouse, inspect the packing for any visible damage and make sure it is in good condition. In the event you detect any damage, please contact your forwarder immediately: send a registered letter to the shipping company claiming the suffered damage, a copy of which should be sent responsible contact in Danfoss.

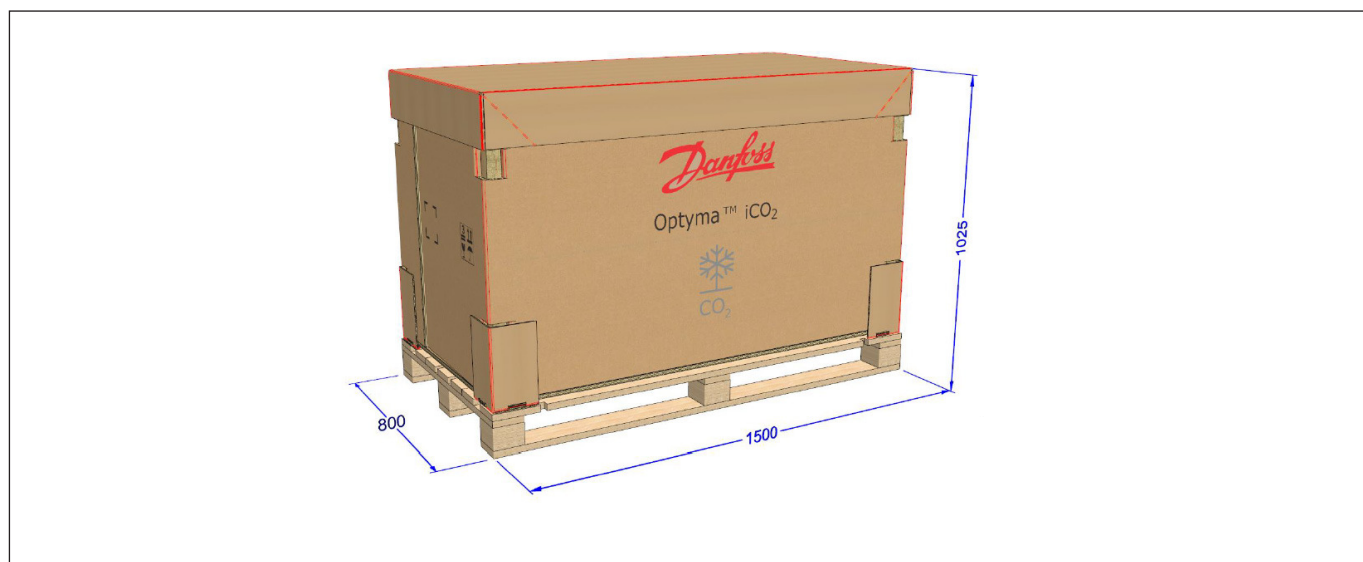
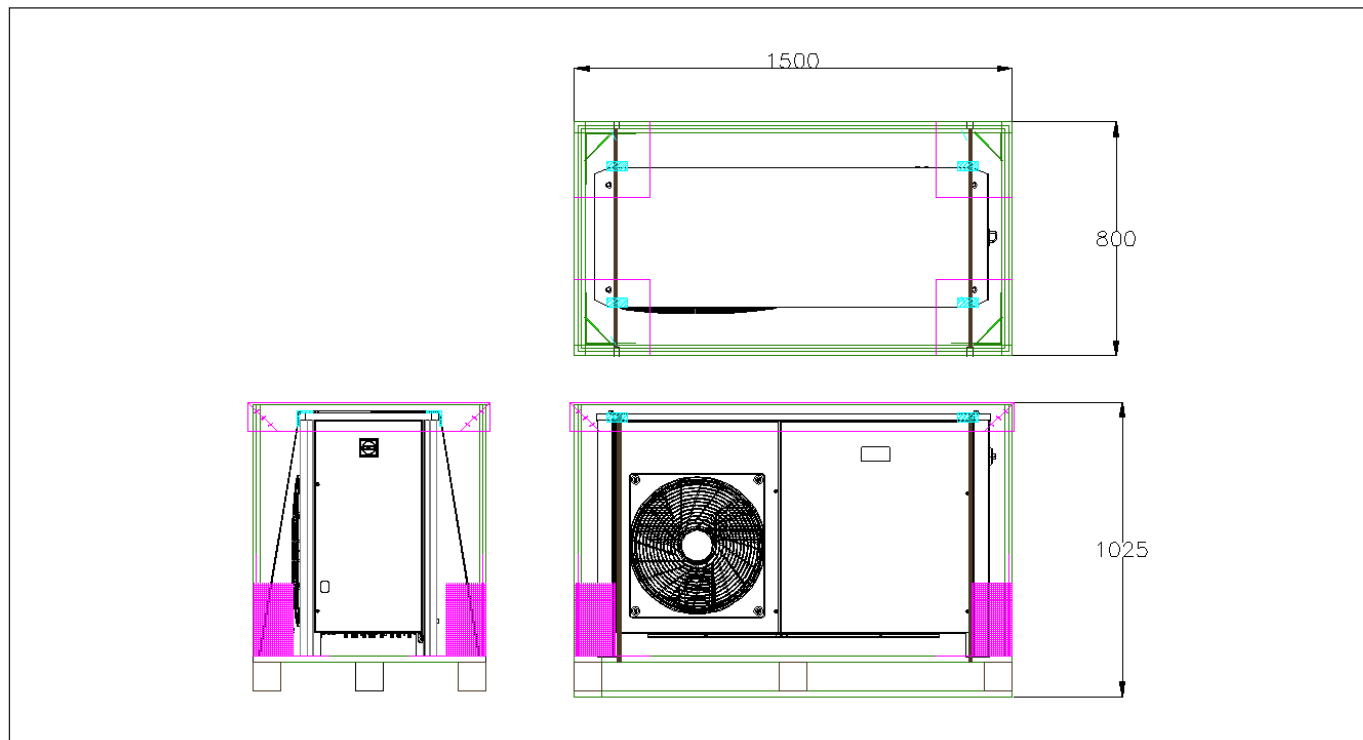

5.2 Disposal Instruction

Equipment containing electrical components must not be disposed of together with domestic waste. It must be separately collected with electrical and electronic waste according to local and currently valid legislation.

6.1 Service and safety advice

If the refrigerant system has been opened the system has to be flushed with dry air or nitrogen to remove moisture and a new filter dryer has to be installed. Beware of hot and cold components in the refrigeration system. The components in the refrigeration system are pressurized; as a consequence special attention has to be paid during operation on these components.

Do not operate condensing unit without refrigerant charge or without being connected to the system.

Safety goggles, gloves, protective clothing, safety boots, hard hats or another safety equipment should be worn when necessary. Never install a system in the field and leave it unattended when it has no charge, a holding charge, or with the service valves closed without electrically locking out the system.

Do not touch the compressor until it has cooled down. Ensure that other materials in the area of the compressor do not get in touch with it.

Before starting a repair work

- Disconnect from mains
- Wait as stated before for discharge of the DC-link. (Refer section 4.5.1 Warning when touching unit when OFF)

Item	Contents
Transportation and delivery	1. Cargo unloading work should be carried out using appropriate handling equipment (Forklifts, cranes, etc.). Do not let the unit fall.
Leak inspection	1. Do not pressurize with oxygen or air for leak inspection. 2. If you find a leak, do leakage inspection again after repair.
Evacuation and Refrigerant charge	Please see specific paragraph 6.9.2.
Trial run	1. Check that the refrigerant is filled. (Do not turn on the compressor in vacuum.) 2. Do not insert or remove electrical connectors during operation.

Failure to comply with the instructions will void the warranty.

6.2 Location & fixings

Install the equipment in a plane surface where air circulates around the equipment and the equipment operates correctly.

Do not install in the following locations:

- A dusty place
- Place with flammable gas atmosphere
- Place where water or oil (contain machine oil) is scattered or where there is a lot of steam
- Place exposed to direct sunlight.
- Place where snow can accumulate : The ambient temperature sensor is located inside one of the condensing unit leg. Snow accumulation will generate wrong ambient temperature measurement.
- Area with high corrosive atmosphere
- Places expose to strong wind.
- Areas with large voltage fluctuations
- Place where there is a machine that generates electromagnetic waves
- Place where not blocking or expose an obstacle for walking areas, doors, windows etc.

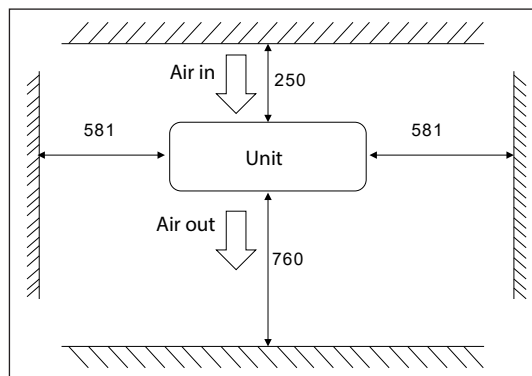

The base shall be installed so that the angle of inclination of the unit is within 2 degrees. The maximum number of stack of the units shall be two and the top unit shall be fixed, see image below. The base must be strong enough to withstand the weight of the unit.

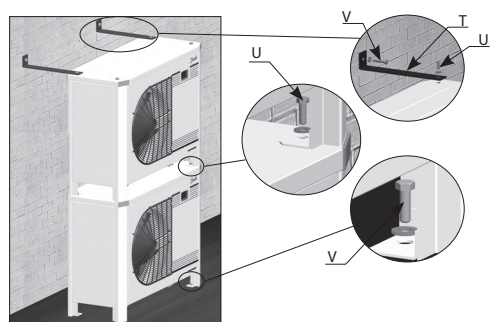

- T:** Mounting brackets for stacked mounting (not supplied)
- U:** M8 bolts for stacked mounting (supplied)
- V:** Mounting bolts (not supplied)

6.3 Power supply connection

Electrical connections shall be performed by qualified personnel in accordance with applicable national legal standards and EN-60204 -1. Before connecting the equipment electrically, confirm that the voltage and frequency rating of the AC power line corresponds to the indication on the identification plate and that the power supply voltage is within the allowable range of +/- 10% of the rated value. Be sure to connect the ground wire (PE). Below table lists recommended wiring sizes for the condensing unit power supply cables. These wiring sizes are valid for a cable length up to 30 m.

Model	Cable size, mm ² (from network to unit main switch)
Optyma iCO ₂	2.5mm ² up to 4.0mm ² depending on ambient temperature and grouping

Note:

The wire size here is the guideline. In each specific case required cable size should be specified by the installer depending on the system design, ambient temperature, the wire material, current, etc.

The unit is equipped with a main switch with overload protection. Overload protection is preset from factory. Value for overload protection can be found in the wiring diagram. Wiring diagram can be found in front door of unit. Unit is equipped with high pressure switch, which directly cuts the power supply of the compressor contactor in case of activation.

The condensing unit is equipped with an electronic controller. The controller is pre-programmed with parameters ready for use.

6.4 Power supply protection

You should use only original circuit breaker, min. short circuit breaking capacity needs to be 100 kA. Please refer to spare part set section for selection of components for service replacement.

RCD type: Type A or B.

6.5 Signal connection

The condensing unit start and stop must be controlled by the cold room thermostat. To activate this control mode, remove the jumper (bridge connection) on digital input DI2 (CNB41 and CNB43) and connect the thermostat relay on the same slots.

With the jumper, the condensing unit is in pressure control mode: unit start and stop depending on suction pressure and low pressure switch limits (user defined limits).

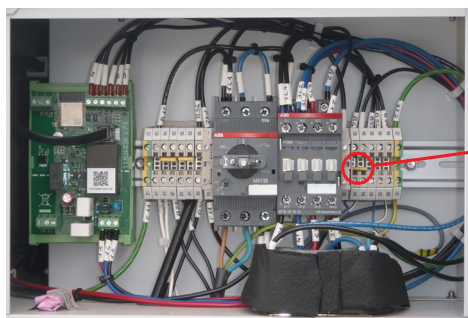

*Jumper on slots CNB41 and 43 bridge the digital input DI2.
Condensing unit is in pressure control mode.*

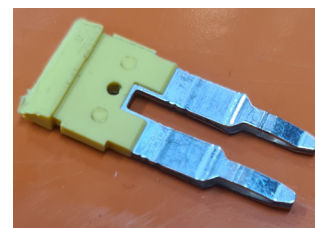

Jumper

6.6 Protection and features

- Thermal compressor protection: 125±5 °C
- Thermal switches for reactor protection against overload.
- HP pressure cartridge setting: cut out 140 bar, cut in 100 bar.
- Receiver pressure relieve valve setting : 80 barg
- The root cause of an individual alarm can be shown with the display.

6.7 Electrical protection standard

Complete unit Ingress Protection Code: IP54

The unit is fully wired and factory tested. Electrical connection compromises only power supply.

6.8 EMC compliance

All necessary actions are taken to secure EMC compliance of complete condensing unit (See declaration of incorporation).

6.9 Warning when touching unit when OFF

Capacitors in condensing unit controller can remain charged even when the condensing unit controller is not powered. To avoid electrical hazards, disconnect AC remains and wait 15 min for the capacitors to fully discharge before performing any service or repair work (see par. 9.4 Alarm indications and Status messages). Failure to wait the specified time after power has been removed before doing service or repair could result in death or serious injury.

6.10 System design recommendation

Pipe work practice

- Be careful not to let foreign matter or water enter in the unit.
- At the time of piping brazing, carry out the process while blowing with nitrogen to suppress the generation of copper oxide.
- During installation of the unit or replacement of CO₂ carrying components it's mandatory to use chlorine free flux material in order to preserve the hydraulic circuit from internal corrosion. Silver flux is admitted but must be chlorine free.

Installation

- Piping must be of refrigeration quality compliant with PED 2014/68/EC and EN 12735 -1.
- Maximum safety length of pipes between CU and last evaporator is 20 m.
- The height difference between the outdoor unit and the evaporator shall be +/- 5 m or less.
- All piping (liquid and return lines) should be covered with insulation to ensure performance.
- The piping connected to the condensing unit must be flexible in 3 dimensions to accommodate vibrations.
- The pipes should be sized to ensure optimum performance and good oil return.
- Do not assume that the liquid and suction connection sizes on the unit are in fact the correct sizes to run your interconnecting refrigeration pipes. The sizing must also take into account the full capacity range through which this particular unit will need to operate.
- Pipe runs should be kept as short as possible, using the minimum number of directional changes

Liquid line

- Liquid line and receiver are protected by a pressure relieve valve connected to the receiver. Pressure limit set at 80 bar.
- All parts of the liquid line must be rated for PS 80 bar.

Suction line

- The design pressure of the evaporator(s) and suction line is preferable to be 80 bar, no less than 60 bar.
- Suction line must be protected by a pressure relief valve (Contractor responsibility) set at the MWP of the evaporators and suction pipe.
- All section of system that can be close by isolation valve must be protected by a PRV or a check valve to allow flow in the direction of a PRV.
- Pressure relieve valve must be place where no risk for people or goods.
- Suction line should be fully insulated (19 mm thickness recommended)
- Design suction pipe to ensure good oil return.
 - Diameter of separate suction lines from evaporators to condensing unit manifold should be with appropriate size according evaporator capacity (securing recommended speed for proper oil return).
 - Common manifold tube should be as close as possible to condensing unit.
 - The suction gas velocity must be sufficient to ensure a good oil return : 4 m/s in horizontal pipes, 8 to 12 m/s in vertical risers.
 - Use oil trap trap for every vertical risers line of more than 2.5 meter length.
 - Secure gentle slope towards the unit (recommended slope minimum 0.5/100)
 - All pipes should be adequately supported to prevent sagging which can create oil traps. Piping must be supported and clamped every 1 meter for D3/8".
 - Use large radius bends and avoid trapping of oil and refrigerant. This is especially important for the suction line.
- Refrigerant velocity: 8 to 12m/s on vapour line and 0,6to 1,2m/s on liquid.

Evaporator

- Total evaporator internal volume should not be less than 2 Liters. below 2 Liters can give some instability of the system : too big variation of pressure and mass flow, CDU controller could not be fast enough to adapt to the dynamic of the evaporator.
- Maximum total evaporator internal volume is 10 Liters for evaporating temperature -5°C and 6 Liters for evaporating temperature +10°C

Ensure if liquid line stub supplied on display case is 80 bar

Evaporator expansion valve selection

The condensing unit can work with

- Stepper valve,
- AKV 10P Pulsating valve (see selection below),

Application Guidelines 6. Installation

- Thermostatic expansion valves, see expansion valve selection upon required cooling capacity

Evaporation temperature (°C)

kW	5	0	-5	-10	-15	-20	-25	-30	-35	-40	-45
	1	AKV 10P1	AKV 10P1	AKV 10P1	AKV 10P1	AKV 10P1	AKV 10P1	AKV 10P1	AKV 10P1	AKV 10P1	AKV 10P1
2	AKV 10P2	AKV 10P2	AKV 10P2	AKV 10P2	AKV 10P2	AKV 10P2	AKV 10P2	AKV 10P2	AKV 10P2	AKV 10P2	AKV 10P2
3	AKV 10P3	AKV 10P3	AKV 10P3	AKV 10P3	AKV 10P3	AKV 10P3	AKV 10P3	AKV 10P3	AKV 10P3	AKV 10P3	AKV 10P3
4	AKV 10P4	AKV 10P4	AKV 10P4	AKV 10P3	AKV 10P3	AKV 10P3	AKV 10P3	AKV 10P3	AKV 10P3	AKV 10P3	AKV 10P3
5	AKV 10P4	AKV 10P4	AKV 10P4	AKV 10P4	AKV 10P4	AKV 10P4	AKV 10P4	AKV 10P4	AKV 10P4	AKV 10P4	AKV 10P4
6	AKV 10P4	AKV 10P4	AKV 10P4	AKV 10P4	AKV 10P4	AKV 10P4	AKV 10P4	AKV 10P4	AKV 10P4	AKV 10P4	AKV 10P4
7	AKV 10P5	AKV 10P5	AKV 10P4	AKV 10P4	AKV 10P4	AKV 10P4	AKV 10P4	AKV 10P4	AKV 10P4	AKV 10P4	AKV 10P4
8	AKV 10P5	AKV 10P5	AKV 10P5	AKV 10P5	AKV 10P4	AKV 10P4	AKV 10P4	AKV 10P4	AKV 10P4	AKV 10P4	AKV 10P4
9	AKV 10P6	AKV 10P5	AKV 10P5	AKV 10P5	AKV 10P5	AKV 10P5	AKV 10P5	AKV 10P5	AKV 10P5	AKV 10P5	
10	AKV 10P6	AKV 10P6	AKV 10P5	AKV 10P5	AKV 10P5	AKV 10P5	AKV 10P5	AKV 10P5	AKV 10P5		

1) The AKV series cannot be used because the differential pressure is greater than the maximum valve opening differential pressure

All pre-selection made here need to be cross check in Coolselector upon dedicated customer need and working envelop, see selection details below

* Coil can be used for AKV10P and AKV10PS valve

Multi-pack code no.	Identical Industrial pack code no.		Identical spare part coil with DIN spade	Supply voltage / power / frequency	Connection type / enclosure rating	MOPD of individual coil (bar)						
	Code no.	Pcs. per pack				AKV10P					AKV 10PS	
						Orifice size						Orifice size
						0-2	3	4	5	6	7-8	PS4-PS8
018F6905	-	-	-	230 V AC, 19 W, 50 Hz	With terminal box, IP67	70	55	55	55	42	20	55

AKV 10P: This is a Direct operated valve.

AKV 10PS: This is a Servo operated valve. 10PS is more dedicated for precise adjustment of the setpoint.

Table: AKVP selection support

Parameter	Recommendation / Value	Notes
Selection Tool	CoolSelector®	All valve selections must be verified in CoolSelector to ensure correct sizing and performance.
Pressure Difference (ΔP)	25 bar	Between receiver and suction (difference between evaporating setpoint and receiver pressure).
Load Factor	60%	Ensures optimal valve performance in both summer and winter conditions.
Applicable Model	Optyma iCO ₂ 4,6MT 114x6001	Specific guidance for this model.
Unsuitable Valves	AKV10P7, AKV10P8	These valves are not recommended for this application.
Reason for ΔP Consideration	Stable operation and correct modulation	Prevents under- or over-feeding of refrigerant.
Seasonal Performance	Balanced	60% load factor helps maintain efficiency across varying ambient temperatures.

When selecting an evaporator expansion valve consider the following :

- There is not subcooling on liquid line : SC = 0 K.
- Max liquid line pressure is Preceiver max = Psuction + 30 bar and no more than 65 bars abs. (Summer conditions).
- Min liquid line pressure is Preceiver min = Psuction + 3 bar (winter condition).

Let say saturated evaporating temperature is -10°C. Evaporating pressure is 26.5 bar abs. Liquid line pressure range from 56.5 bar abs (summer) to 29.5 bar abs (winter). Liquid line saturated temperature range from 19.4°C (summer) to -6.2 °C (winter).

Application Guidelines 6. Installation

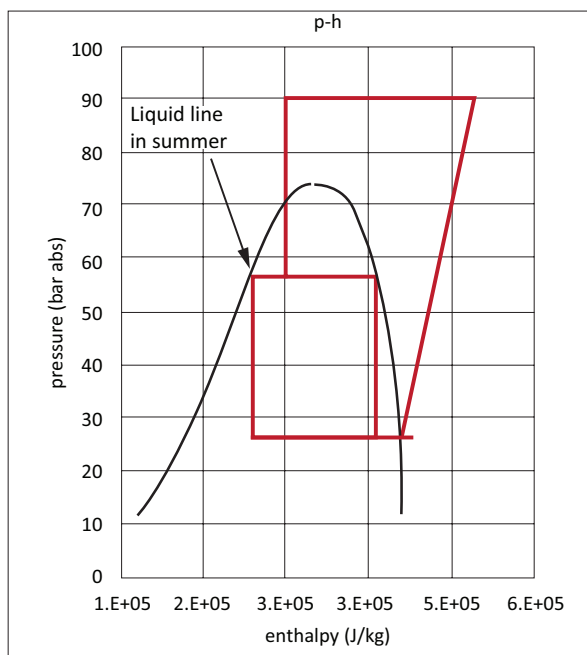
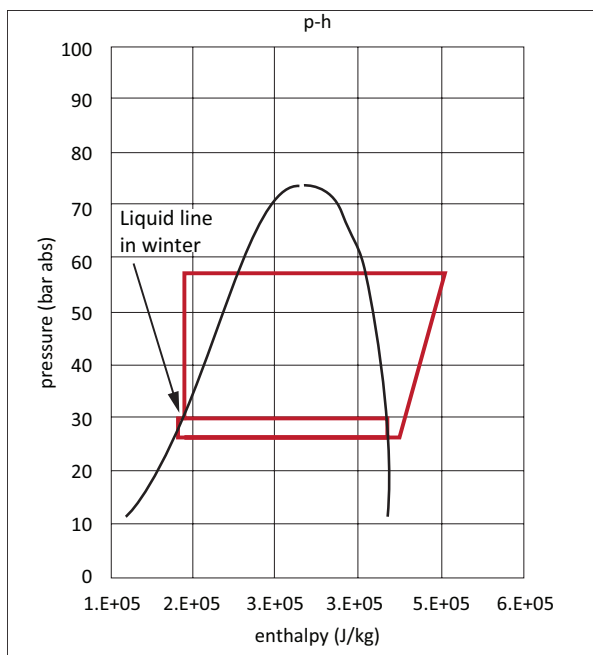

The installer is responsible for the installation of the unit and complete refrigeration system design according to particular conditions of each application as this is not scope of current Guideline.

Tube size	Distance between 2 clamp supports
3/8"	1.0 m

Pipe line	Minimum refrigerant velocity
Suction line	8-12 m/s
Liquid line	0.6-1.2 m/s

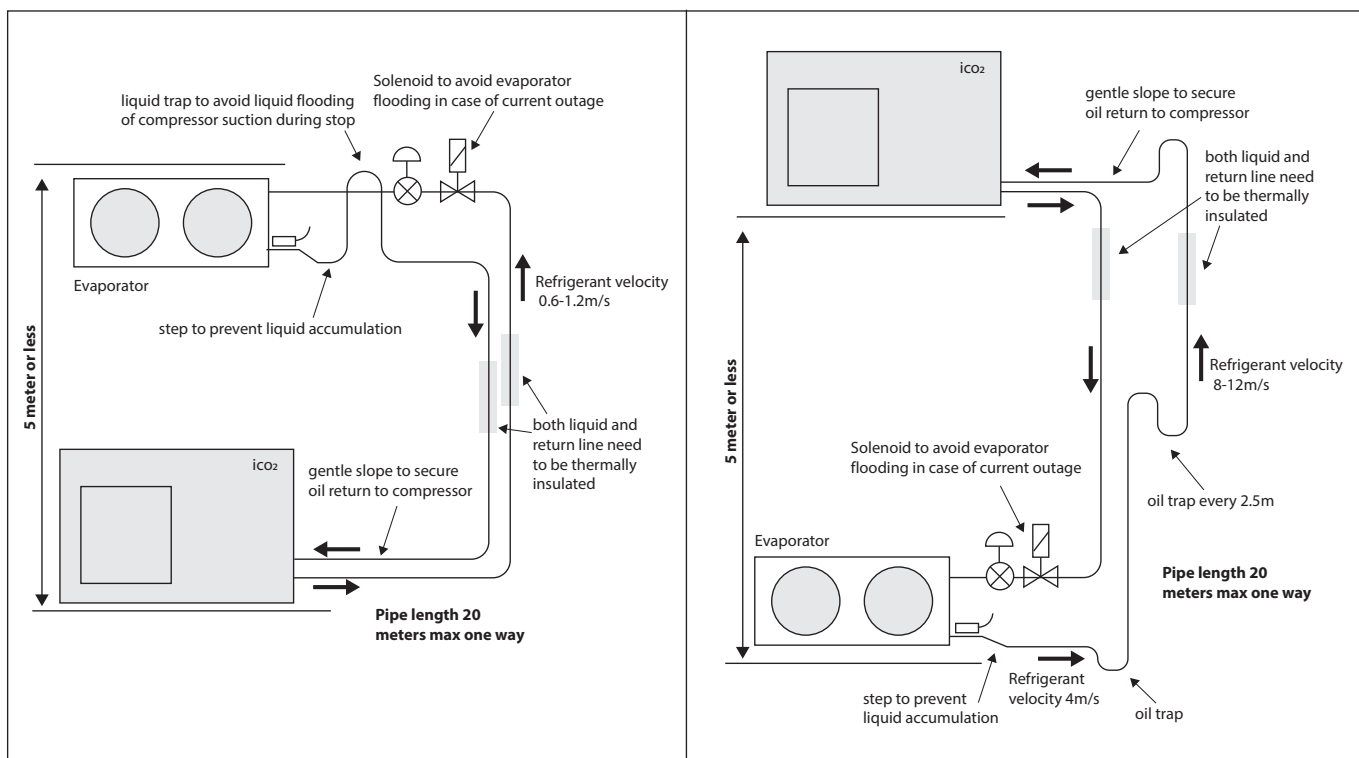

6.11 Leak and pressure test

Pressure tests :

- Test liquid line at $1.1 \times PS = 88$ bars.
- Test suction line at $1.1 \times PS$ according to suction line design pressure (60 or 80 bars).
- When testing at 88 bar, close unit shutoff valve to prevent the receiver PRV to blow-out. Condensing unit does need to be tested at 88 bar. It has already been pressure tested in factory.
- Don't forget to remove suction line PRV and place it back again after pressure test and before leak test.
- During gas cooler replacement (118U4112/118U4116), the high side should be pressure tested with 154 bar.

leak test

- Perform a leak detection test on the complete system at pressure $P = 0,25 \times PS = 20$ bar.
- When a leak is discovered, repair the leak, and repeat the leak detection.

After completion of test, vent nitrogen to atmosphere and open condensing unit service valve.

6.12 Oil charge calculation

The condensing unit is supplied with PAG oil, the oil separator and accumulator is pre-charged with 268 g (Total charge 268 g = 158 g compressor charge + 110g suction accumulator charge).

Use the provided excel file in order to identify the amount of oil that must be added. The calculation already include 20 m + 20 m of pipes between CDU and evaporator so it's only requested to fill in:

- Number of evaporators
- Max Ambient temperature

Calculation assume evaporator volume to be 2 Liters. Add 50 g of oil for each Liters above 2 liters.

Highest the setting of the oil return strategy, lowest the oil amount that must be added. See example below

<input>		➔	<Output>	
Evaporator unit ($\leq 2.0L/unit$)	1 unit		Oil return control set value	Amount of additional Oil
Suction set point temperature	-15°C		Unnecessary	430g, but the oil return is not good
Highest operating ambient temperature	35°C		3000rpm (Default)	190g
			4500rpm	No add oil
			5600rpm	No add oil

Oil boost speed is default 3000 rpm, you can see in the below chart oil addition for two different ambient temperatures and different evaporator volumes.

(The default oil boost speed us 3000 rpm, this can be increased however it could lead to increased compressor noise and sharp reduction in evaporating temperature as well as increased discharge temperature)

TA	°C	38
Oil boost	rpm	3000

TA	°C	32
Oil boost	rpm	3000

Oil Addition (gr)

Evap Vol	Te [°C]			
Liters	-15	-10	0	5
2	430	430	430	190
4	530	530	530	290
6	630	630	630	390

Oil Addition (gr)

Evap Vol	Te [°C]			
Liters	-15	-10	0	5
2	190	190	190	0
4	290	290	290	100
6	390	390	390	200

If additional oil is require, you can fellow bellow procedure.

6.13 Oil addition

- Open condensing unit ball valves
- Connect a flexible house to the condensing unit suction port and vent the nitrogen charge
- Pump require volume of oil into suction line with a stirrup pump. Ensure pump is full of oil before connecting the pump to suction service port.

Instead of a stirrup pump, it is also possible to use the vacuum pump to charge oil :

- Set condensing unit to vacuum mode (see next section)
- Connect vacuum pump to liquid line shradr port
- Connect a flexible hose to suction port to suck oil from the can.

Note:

Oil can 250 ml inside the Optyma™ iCO₂ packaging already supplied by Danfoss.
Do not charge oil through the liquid service valve; do not charge oil when the compressor runs.

6.14 Evacuation

Vacuum shall be applied after completion of leakage inspection and oil addition.
Do not test electrical strength of the compressor motor insulation while it is under vacuum, to prevent motor damages.

- Select Vacuum mode by changing parameter "r12" to "2". The stepper valves will fully open within the 10 seconds.
- Connect the vacuum pump to liquid service valves (and open the service valve).
- Turn on the vacuum pump, keep this condition for at least 4 hours min.
- Check if gauge is showing 0.67mbar (absolute) after 4 hours since the start of vacuuming.
- In case if pressure was not able to reach to 0.67mbar (absolute) within 4 hours, break the vacuum with Nitrogene gas with 1 bar, restart vacuum procedure, repeat 3 times to eliminate all moisture and impurities.
- In case of use at higher altitude place pressure read does not reach to 0.67mbar (absolute) in the short duration, prolong the vacuum time for 30minutes more.
- Shut stop-valve of vacuum pump hose.
- Turn OFF the vacuum pump.
- Leave them for 30 min. Then check that vacuum gauge read does not show any changes (i.e. keeping 0.67mbar (absolute) for 30 min.
- If pressure increases rapidly, the system is not airtight. Locate and repair leaks. Restart the vacuum procedure, followed by steps 1, 2 etc.
- If pressure increases slowly, the system contains moisture inside. Break a vacuum with nitrogen gas and restart the vacuum procedure
- After confirming the stable 0.67mbar (absolute), go to charge refrigerant.

Suggested actions if vacuum level cannot be reached or pressure gauge readings change:

- Check hose connections for any leakage.
- Check flare connections if tightened.
- Check copper brazing for any leakage.
- Remaining CO₂ gas can still diffuse out of the oil. Retry vacuuming for 10min.

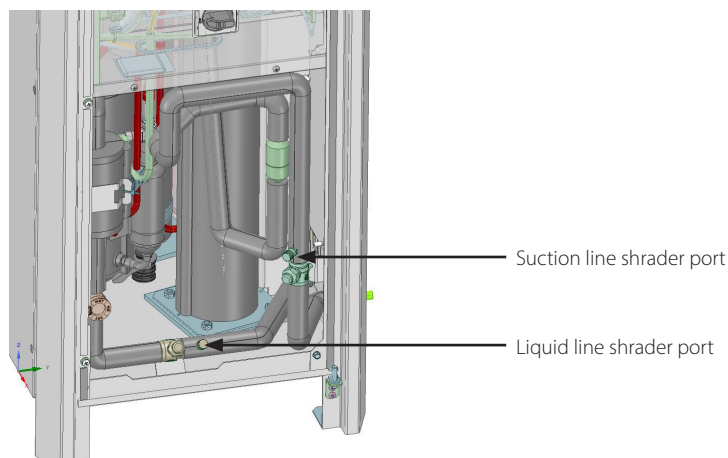

6.15 Refrigerant charge calculation

Use refrigeration CO2 purity 99.995% (grade 4.5), humidity H2O < 5 ppm.

Refrigerant charge amount must be calculated and system charge must be done using a scale. DO NOT use the sight glass as an indicator of correct / incorrect charge amount in the system.

Refrigerant charge amount can be calculated by provided excel file.

Refrigerant charge amount can also be estimated using below equations :

- System charge M = CDU charge + liquid line charge + evaporator charge
- Condensing unit need 2.15 kg of CO2 to run properly
- Liquid line mobilize approximately 0.80 kg/L of CO2. This correspond to 0.04 kg/m for liquid line D3/8.
- Evaporator mobilize approximately 0.25 kg/L at evaporating temperature TE = +10°C and 0.15 kg/L at TE = -5°C

Condensing charge should never exceed 3.50 kg. Max system charge is then 3.50 kg + liquid line charge. And **max evaporator charge is 1.35 kg.**

Charge equation

System Charge M =	Condensing unit charge	+ Liquid Line charge	+ Evaporator charge
System Charge M =	2.15 kg	+ 0.80 kg/L x Liquid Line Volume Corresponding to 0.04 kg/m for liquide line D3/8.	+ 0.25 kg/L * evap volume for TE = +10°C +0.15 kg/L * evap volume for TE = -5°C But no more than 1.35 kg.

Evaporator and liquid line charge are given below versus volume and pipe diameter.

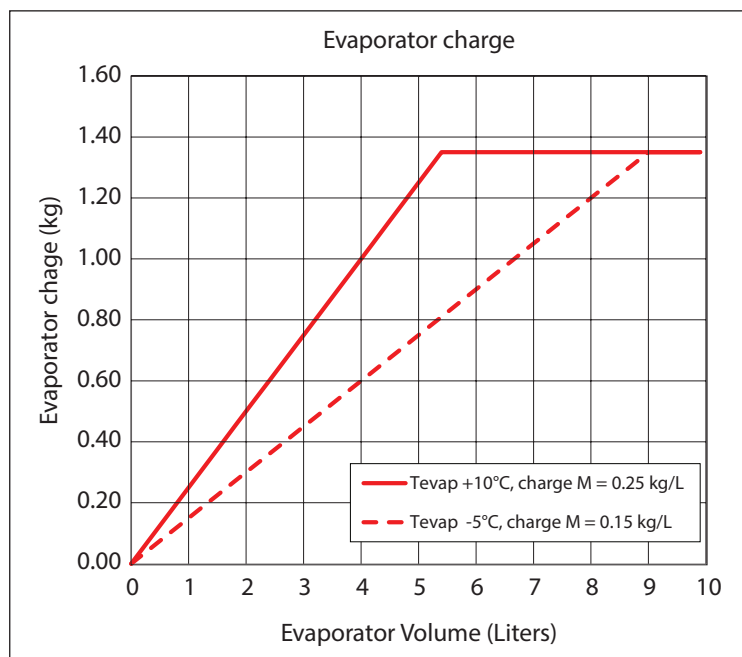

Application Guidelines

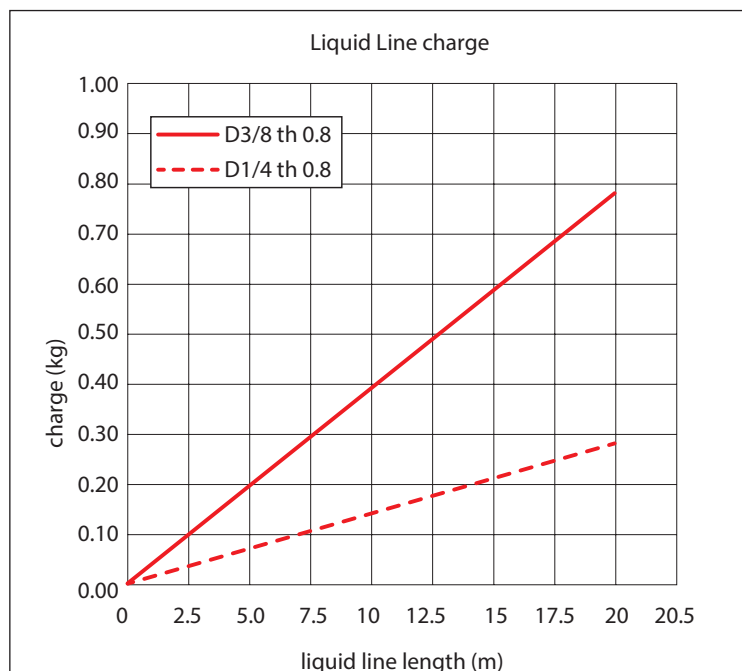

Bellow example of calculation results for liquid line D3/8, thickness 0.8 mm and different liquid line length and evaporator volume. Evaporating temperature assume to be +10°C.

Liquid Line D3/8 th 0.8 mm		Evaporator Volume (Liters)					
length	volume						
m	Liters	1	2	3	4	5	6 and above
0.00	0.00	2.40	2.65	2.90	3.15	3.40	3.50
5.00	0.25	2.60	2.85	3.10	3.35	3.60	3.70
10.00	0.50	2.80	3.05	3.30	3.55	3.80	3.90
15.00	0.75	3.00	3.25	3.50	3.75	4.00	4.10
20.00	1.00	3.20	3.45	3.70	3.95	4.20	4.30

6.16 Refrigerant charge method

Several charging method are possible. You can for instance charge in liquid phase on liquid line after having break the vacuum with 5 - 10 bar of vapor.

Bellow we describe in detail the easiest charging method. It will work for both suction line PS 80 and 60 bar :

- Check condensing unit is in vacuum mode. Parameter r12 should be set to value 2. This will force HP and BP valve fully open.
- Put CO₂ cylinder on the scale. Connect to the condensing unit. Make the zero.
- Charge the condensing unit on suction line in vapor phase till you reach a pressure bellow suction line PS - 20%.
- Set the condensing unit to automatic mode, r12 = 1. Condensing unit should start.
- Charge the rest of the calculated CO₂ refrigerant progressively.

Note :

- Never charge liquid in suction line. It risks to damage the compressor.
- Do not overcharge the system. Overfilling the system may risk in pressure increase and release of refrigerant through the receiver relief valve during standstill. Overfilling the system may risk of liquid return to compressor inlet when running.
- You should always charge with a scale. Condensing unit sight glass is not a reliable indication of charge correctness.

Check the charge

- Overcharged system will show very low compressor suction superheat
- Low charge will give low suction pressure, large superheat at evaporator outlet, large evaporator valve opening degree.
- If you suspect wrong charge, double check your calculation, pipe length, evaporator volume, empty the system and re-do the charge.
- Check system restart correctly after a pump down.
- Once you reach steady condition, check system run correctly in high ambient condition by covering gascooler.

Record type and amount of refrigerant charge as well as operating conditions as a reference for future inspections

Never leave the filling cylinder connected to the circuit. Disconnect and remove refrigerant bottle from the unit, close Schrader valves with their protection caps.

6.17 Check before start

1. Compliance between unit and power supply
2. Check the service valves inlet/outlet both are opened
3. Check that fan can rotate freely
4. Check for possible faults in the installation
5. Check main switch overload protection setting

6.18 inspection before maintenance

Even if main switch of condensing unit is in position OFF power still available at income terminals of main switch.

In case of any service related to electrical components inside condensing unit it is recommended to disconnect condensing unit from the power by switch located before condensing unit.

It is recommend to check the unit for leakages minimum once a year.

Furthermore following should be checked:

1. Electrical and refrigerant connections for damages, corrosion etc.
2. The mounting devices (bolts, nuts, etc.) of the unit.
3. Vibrations: if it is on the same level as after installation or any signs of abnormal vibration.
4. Operation conditions.
5. Airflow across the gas cooler.
6. Tightness of electrical connections.

6.19 Gas cooler maintenance

Gas cooler should at least once a year be checked for clogging and be cleaned if deemed necessary. Access to internal side of condenser through fan door. Remember to switch off the unit at main switch before opening the fan door.

In comparison to fin and tube heat exchangers, microchannel coils tend to accumulate more of the dirt on the outside surface which can make them easier to clean.

Step 1: Remove surface debris

Remove surface dirt, leaves, fibers, etc. with a vacuum cleaner (preferably with a brush or other soft attachment rather than a metal tube), compressed air blown from the inside out, and/ or a soft bristle (not wire!) brush. Do not impact or scrape the coil with the vacuum tube, air nozzle, etc.

Step 2: Rinse

Do not use any chemicals (including those advertised as coil cleaners) to wash microchannel heat exchangers. They can cause corrosion. Rinse only with water.

Hose the MCHE off gently, preferably from the inside out and top to bottom, running the water through every fin passage until it comes out clean. Microchannels fins are stronger than traditional tube & fin coil fins but still need to be handled with care. Do not bang the hose into the coil.

Step 3: Optional blow dry

Microchannel heat exchangers, because of their fin geometry, tend to retain water more than traditional fin & tube coils. It may be beneficial to blow or vacuum out the rinse water from your unit to speed drying and prevent pooling

7.1 WARNING

WARNING: remember to remove compressor protection during installation procedures.

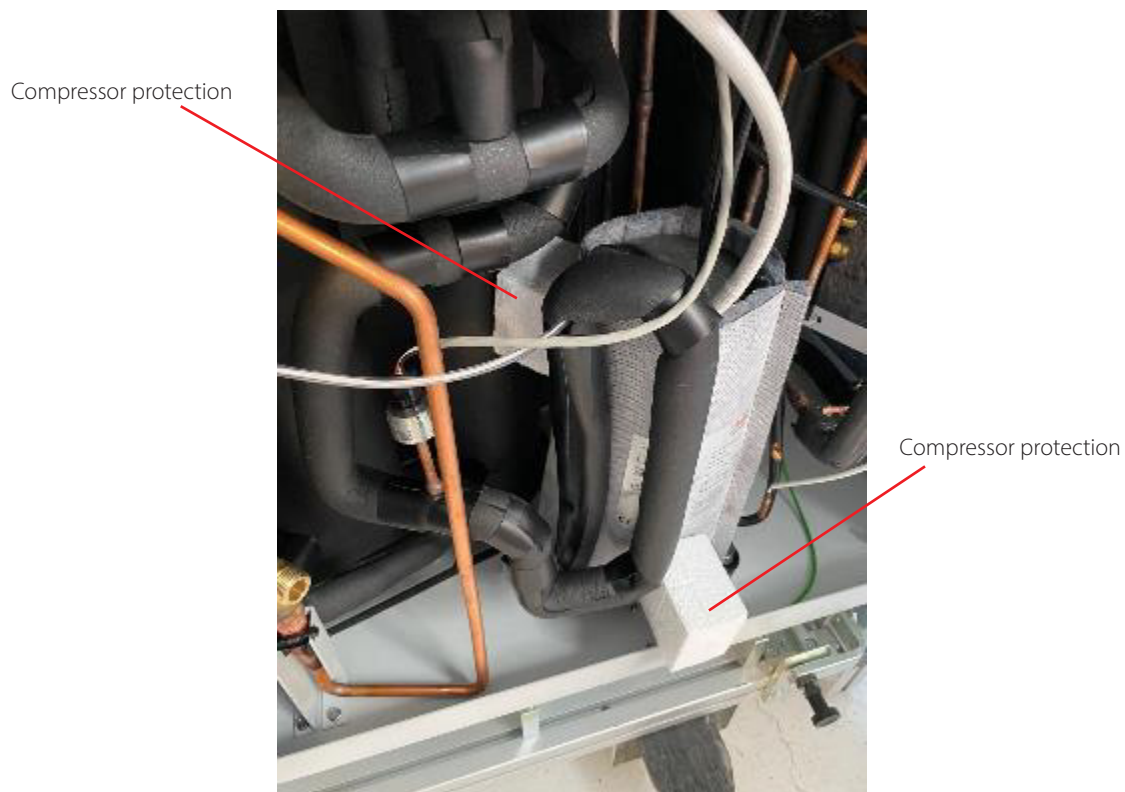

8.1 CDU CO₂ – Optyma™ iCO₂ label

A	OP-MPAM005COP04G	 MADE IN ITALY
B	114X6001	
C	Application MBP IP54	
D	Refrigerant R744	
E	PS-HP 140bar	
F	PS-MP 80bar	
G	PS-LP 80bar	
H	Voltage 230V 1N ~50Hz	
I	LRA Inverter driven MCC 15 A	
J	OIL INSIDE PAG ND8 268cc (268cc=158cc compressor + 110 suction accumulator)	
K	Serial No. 000102DT1821	
L	EAN No. 5702424493981	
M	MR117403-6570	 Only for Norway

- A:** Model
- B:** Code number
- C:** Application, IP protection level
- D:** Refrigerant (R744=CO₂)
- E:** High side working pressure
- F:** Liquide line circuit working pressure
- G:** Suction line working pressure
- H:** Supply voltage
- I:** Locked Rotor Ampere, Maximum Current Consumption
- J:** Oil type
- K:** CDU serial number
- L:** European Article Number
- M:** Condensing unit Label PN (Factory)

8.2 Compressor label

Compressor		 MADE IN ITALY				
A	Model no : 118U4105					
B	Serial no : 10D00001					
C	CDU Serial no : 000101CG1821					
		230V 1N ~50Hz through inverter ← E MAX OPER. 15A ← F Thermally protected ← G P.E.D. class1 ← H PS LP Side 80 bar HP Side 140 bar ← I Frequency: 37 - 114Hz ← L Speed: 2200 to 6840 rpm ← M Lubricant: PAG ND8 158cc ← N Refrigerant: R744 ← O				
D	MR117403-6580	<table border="1"> <tr> <th>WARNING</th> <th>CAUTION</th> </tr> <tr> <td> Installation and servicing shall be performed by trained personnel only. Failure to observe these safety warnings could result in electric injury or death. ELECTRIC SHOCK HAZARD: Turn off power before servicing. (Indicates all operations.) Keep the metal cover in place and securely fastened whenever power is applied to the compressor. Use this equipment on a grounded system only. HIGH PRESSURE: System contains a refrigerant and oil under pressure. Relieve pressure from both the high and low side before servicing, wear safety goggles. FIRE HAZARD: Use halting outlet to remove compressor. Do not use catch as it may catch fire. </td> <td> Use only manufacturer's approved refrigerants, lubricants and electrical components. Unauthorized refrigerant / lubricant / electrical component could cause fires, explosions, electrical shorting. For details refer to multi language instructions and technical documentation available on Danfoss website at http://fcc.danfoss.com </td> </tr> </table>	WARNING	CAUTION	Installation and servicing shall be performed by trained personnel only. Failure to observe these safety warnings could result in electric injury or death. ELECTRIC SHOCK HAZARD: Turn off power before servicing. (Indicates all operations.) Keep the metal cover in place and securely fastened whenever power is applied to the compressor. Use this equipment on a grounded system only. HIGH PRESSURE: System contains a refrigerant and oil under pressure. Relieve pressure from both the high and low side before servicing, wear safety goggles. FIRE HAZARD: Use halting outlet to remove compressor. Do not use catch as it may catch fire.	Use only manufacturer's approved refrigerants, lubricants and electrical components. Unauthorized refrigerant / lubricant / electrical component could cause fires, explosions, electrical shorting. For details refer to multi language instructions and technical documentation available on Danfoss website at http://fcc.danfoss.com
WARNING	CAUTION					
Installation and servicing shall be performed by trained personnel only. Failure to observe these safety warnings could result in electric injury or death. ELECTRIC SHOCK HAZARD: Turn off power before servicing. (Indicates all operations.) Keep the metal cover in place and securely fastened whenever power is applied to the compressor. Use this equipment on a grounded system only. HIGH PRESSURE: System contains a refrigerant and oil under pressure. Relieve pressure from both the high and low side before servicing, wear safety goggles. FIRE HAZARD: Use halting outlet to remove compressor. Do not use catch as it may catch fire.	Use only manufacturer's approved refrigerants, lubricants and electrical components. Unauthorized refrigerant / lubricant / electrical component could cause fires, explosions, electrical shorting. For details refer to multi language instructions and technical documentation available on Danfoss website at http://fcc.danfoss.com					

- A:** Spare part PN
- B:** Compressor serial number
- C:** Condensing unit serial number
- D:** Compressor Label PN (Factory)
- E:** Supply voltage
- F:** Maximum Current Consumption
- G:** Compressor protection type
- H:** Pressure Equipment Directive and classification
- I:** Min and Max working pressure
- L:** Min and Max compressor operation frequency
Electrical frequency is twice 74 ... 228Hz (4-pole motor)
- M:** Min and Max compressor operation rotation speed
- N:** Oil type
- O:** Refrigerant (R744=CO₂)

CAUTION: Variable speed compressor electric supply via Danfoss approved frequency converter only.

9.1 MMIDLS product description



- Preset controller
- LED display 3-1/2 digit
- Easy connection through CANbus to Danfoss Optyma iCO₂ gateway
- Pre-programmed
- Give a master connection to the drive
- Indicate and record errors and alarms

Dimensions

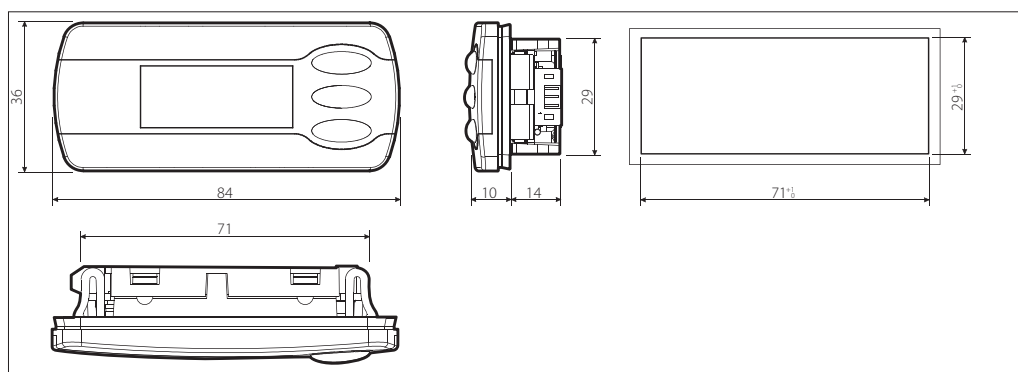

User interface

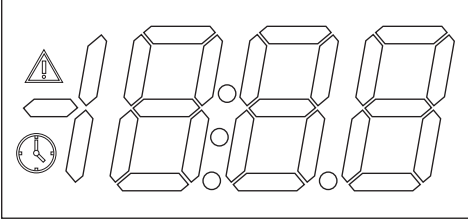
TYPE	FEATURES	DESCRIPTION
LED display	Display	LED 3-1/2 digits + sign 
	Digits	Green colour
	Allarm/warning icons	Red colour
	Dimensions	45 x 17 mm
Keyboard	Number of keys	3
	Keys function	Set by the application software

Common MMILDS display operation

- Press the upper button for more than 3 seconds to get access to parameter menu. The first parameter "r05" is shown on the display.
- Press short upper or lower button to go to the next or previous parameter.
- Press the middle button briefly to show the value of the selected parameter.
- Press the upper or lower button to change the value of the selected parameter.
- The parameter value will be stored with a short press on the middle button.
- The parameter menu closes, and display returns to the main screen after 10 seconds without any activity on the buttons. It shows again the saturated suction temperature in °C.

9.2 Survey of functions

Function	Parameter	Parameter by operation via data communication
Normal display		
The display shows the saturated temperature value of the suction pressure Ts.	---	Ts
Regulation		
Unit Set here if the display should show SI-units or US-units 0: SI (°C and bar) 1: US (°F and Psig).	r05	r05 Temp.unit °C=0 / °F=1 (Only °C on AKM, whatever the setting)
Start / stop of refrigeration With this setting the condensing unit can be started, stopped, vacuumized or a manual override of the outputs be allowed. For manual control the value is set to -1, then outputs like fan motor speed F07 can be force controlled by the respective parameter F20. Start / stop of refrigeration can also be accomplished with the external switch function connected to a digital input. The digital input must be shorted, if the external switch function is deselected. Stopped refrigeration will give a "Standby alarm".	r12	r12 Main switch -1: Manualmode 0: Stop 1: Start 2: Vacuum
Day / Night status Status of Day / Night (on or OFF), 1 = on = Night operation.	u13	u13 NightCond
Reference Ts Setpoint Saturated suction pressure Ts setpoint (°C/°F).	r23	r23 Ts Ref
Reference Ts Reading Readout of Saturated suction pressure Ts (°C/°F).	r24	--- Reference
Reference Ts Offset Value added to the Reference r23 in the night.	r43	r43 Night Offset
Compressor		
Compressor min. speed Here set the minimum allowable speed for compressor.	c46	c46 Min Speed
Compressor max. speed Upper limit for compressor speed during day operation.	c 48	c48 Max Spd Day
Compressor max. Speed night Upper limit for compressor speed during night operation.	c 69	c69 Max Spd Night
Minimum suction pressure Enter the lowest permitted suction pressure here, where the compressor should stop, if the pressure drops below this minimum value.	c 75	c75 Ps OFF
Restart suction pressure Enter the permitted suction pressure here, where the compressor should restart, if the pressure rises after a stop and exceed this limit.	c 76	c76 Ps ON
Low pressure ON/OFF type: 0=dynamic; 1=absolute With absolute settings, LP ON and OFF are directly defined by saturated temperature (c75, c76). With dynamic settings, LP ON and OFF are defined relative to reference suction saturated temperature Ts and ambient temperature Ta (c78, c79,c80).	c77	c 77 LPswitchType
LPON / To offset on Dynamic Pump-Down Offset of LPON compared to saturated suction temperature.	c78	c78 LPDynOffsetTo
LPON / Ta offset on Dynamic Pump-Down Offset of LPON compared to ambient temperature.	c79	c79 LPDynOffsetTa
LPON/OFF hysteresis on Dynamic Pump-Down Offset of LPOFF compared to LPON	c80	c80 LPDynOffsetON
Oil return management Judgement speed If the compressor exceeds this limit, a time counter will be increased. It will be decreased if the compressor speed falls down below this limit.	P77	P77 Spd Thrshld
Oil return management Judgement time Limit value above described time counter. If the counter exceeds this limit, the compressor speed will be raised to the boost speed.	P78	P78 Jdgmnt Oil R
Oil return management Boost speed This compressor speed ensures that the oil returns to the compressor.	P79	P79 Spd Oil Ret
Oil return management Boost time The compressor operates for this period of time with above boost speed.	P80	P80 Time Oil Ret

Application Guidelines 9. MMIDLS specification

Function	Parameter	Parameter by operation via data communication
Fan		
Fan speed The actual fan speed is read out here as a % of the nominal speed.	F07	F07 Fan Speed%
Maximum fan speed day The fan's top speed during day time can be limited here. The value can be entered by setting the nominal speed from 100% to the desired percentage.	F19	F19 Max Spd Day
Manual fan speed control An override of the fan speed control can be done here. This function is only relevant when the main switch is in service mode (r12=-1). 0=Stop; 1=Low; 2=Medium; 3=High.	F20	F20 Manual Fan%
Max Fan speed night The fan's top speed during night time can be limited here. The value can be entered by setting the nominal speed from 100% to the desired percentage.	F22	F22 Max Spd Nght
Real time clock (RTC)		
Switch to day operation Enter the start time where the control reference, fan and compressor speed shall switch back to normal control.	t17	t17 Day start h
Switch to night operation Enter the start time where the control reference shall be raised and where the fan and compressor speed limited.	t18	t18 Night start h
Realtime Clock hour setting.	t07	t07 Clk Hours
Realtime Clock minutes setting.	t08	t08 Clk Minutes
Miscellaneous		
Controller address If the controller is built into a data communication network, it must have a unique address and the master of the system must know this address.	o03	o03 Unit Addr
Software version of the Condensing Unit controller	o08	o08 SW version
Evap. Expansion valve type (0 = Stepper or TXV, 1 = AKV) With Stepper valve, receiver pressure limit at standstill is 76 bar. With AKV valve, receiver pressure limit at standstill is 30 bar above suction pressure.	o09	o09 EXV Type
Factory reset This parameter should reset the gateway and the Condensing Unit Controller when set to 1. It should also stop the Condensing Unit.	o67	o67 Make Factory
Injection ON Condensing Unit status for Evaporator control to allow the evaporator controller to inject. Injection ON is a Modbus master function.	u99	--- Injection ON
Statistic		
Operating time for condensing unit The condensing unit's operating time can be read here. The read-out value must be multiplied with 1000 to get the correct hour value. It can be adjusted if required.	P48	P 48 Unit Runtime
Operating time for compressor The compressor's operating time can be read here. The read-out value must be multiplied with 1000 to get the correct hour value. It can be adjusted if required.	P49	P 49 Comp Runtime
Number of HP alarms The number of high pressure alarms can be read here. It can be adjusted if required.	P51	P 51 HP Alarm Cnt
Number of LP alarms The number of low pressure alarms can be read here. It can be adjusted if required.	P52	P 52 LP Alarm Cnt
Number of high discharge alarms The number of high discharge temp. alarms can be read here, can be adjusted if required.	P53	P 53 DisAlarm Cnt
Service		
Measured High pressure	u01	u01 Pc bar
Status of gateway Digital Input 1 (DI1 = evaporator controller alarm; 0=no alarm)	u10	u10 DI1 Status
Calculated Superheat	u21	u21 Superheat K
Status of gateway Digital Input 2 (DI2 = request from cold room thermostat; 0=no request)	u37	u37 DI2 Status
Readout of Compressor speed in %	u52	u 52 CompCap%
Status of gateway Alarm Relay	U62	U62 Alarm Relay
Measured Gascooler outlet temperature	U05	U05 Sgc Temp
Measured Receiver inlet temperature	U07	U07 Srec2 temp

Application Guidelines 9. MMIDLS specification

Function	Parameter	Parameter by operation via data communication
Measured Receiver pressure (gateway option) - CURRENTLY NOT AVAILABLE	U08	U08 Prec pressure
Converted Receiver pressure (gateway option) - CURRENTLY NOT AVAILABLE	U09	U09 Trec temp
Converted High pressure	U22	U22 Tc
Measured Suction pressure	U23	U23 Po
Converted Suction pressure	U24	U24 To
Ambient temperature	U25	U25 T Ambient
Discharge temperature	U26	U26 T Discharge
Suction temperature	U27	U27 T Suction
Low pressure OFF effective low pressure limit at which compressor stop	U78	U78 DynLP OFF
Low pressure ON Effective low pressure limit that force compressor to restart.	U79	U79 DynLP ON
Gateway software version	U80	U80 GW version
High pressure valve opening degree OD	U91	U91 Vhp %
Receiver pressure valve opening degree OD	U92	U92 Vrec %

9.3 Alarm indications and Status messages

Alarm indications	
Function	Code
Gascooler outlet Temperature sensor error	E20
Ambient Temperature sensor error	E31
Discharge Temperature sensor error	E32
Suction Temperature sensor error	E33
Suction Pressure sensor error	E39
Receiver inlet Temperature sensor error	E40
Receiver Pressure sensor error (option)	E41
Gascooler pressure sensor Error	E42
MMILDS display communication Error	E90
Low Pressure Alarm - pressure limit 14 bar (-28.5°C)	A2
High Pressure Alarm - pressure limit 148 bar	A17
Gascooler low fan speed Alarm - fan speed <= 100 rpm for 60 seconds	A34
Main Switch Off Alarm (r12=0 or D12=0)	A45
Receiver Temperature Alarm	A85
Discharge Temperature Alarm - Temperature above 138 deg.C for more than 5 seconds	A96
High pressure switch - safety Alarm - pressure limit 140bar	A97
Unit Controller / Inverter error code (internal)	H23
Electrical circuit failure on the inverter	H24
Motor current sensor failure on inverter	H25
Input current sensor failure on inverter	H26
Motor current error (phase open)	H27
Other error for compressor or inverter	H28
Abnormality, compressor speed not increasing	H29

Status messages	
Function	Code
Wait for communication to CU conroller	----
No communication to CU controller	F0...F99
Normal Control	S0
Stopped by Main switch: Internal (r12) or external (D12)	S10
Thermostat cutout on D12	S11
Manual Mode (r12=-1)	S25
Safe Stop (Pressure and Temperature safety switches on D11)	S34
Restart state 101 (High pressure)	Sr1
Restart state 102 (Fan motor)	Sr2
Restart state 103 (Discharge temp)	Sr3
Restart state 104 (Receiver pressure)	Sr4

9.5 Parameters of MMIDLS

Parameter		Code	Minimum value	Maximum value	Factory setting	Actual
Function						
Regulation						
Selection of SI and US units: 0=SI (°C-barg) and 1=US (°F-psig)		r05	0	1	0	
Control Main switch: -1=Manual; 0=Stop; 1=Automatic; 2=Vacuum mode		r12	-1	2	0	
Day / Night mode: 0=Day (normal); 1=Night	*	u13	0	1	-	
Reference Setpoint: Saturated suction pressure Ts setpoint (°C/°F)		r23	-20.0 °C	10.0 °C	-10.0 °C	
Readout of Saturated suction pressure Ts (°C/°F)	*	r24	-40.0 °C	50.0 °C	-	
Reference Offset: Value added to the Reference r23 in the night		r43	0 K	10 K	2 K	
Compressor						
Min comp. capacity		c46	32%	58%	32%	
Max comp. capacity during day operation		c 48	59%	100%	100%	
Max comp. capacity during night operation		c 69	59%	100%	80%	
Low Pressure OFF absolute		c 75	-25.0 °C	30.0 °C	-15 °C	
Low Pressure ON absolute		c 76	-20.0 °C	30.0 °C	-5.0 °C	
Low pressure ON/OFF type: 0=dynamic; 1=absolute		c77	0	1	0	
LPON / To offset on Dynamic Pump-Down		c78	-30.0°C	10.0 °C	-5.0 °C	
LPON / Ta offset on Dynamic Pump-Down		c79	-30.0°C	10.0 °C	-5.0 °C	
LPON/OFF hysteresis on Dynamic Pump-Down		c80	-30.0°C	0.0 °C	-5.0 °C	
Compressor speed threshold for oil return control		P77	33%	58%	35%	
Judgment time for oil return control		P78	5 min	720 min	20 min	
Compressor speed during oil return control		P79	35%	100%	44%	
Operation time for oil return control		P80	10 s	600 s	60 s	
Fan						
Readout of Fan speed in %	*	F07	0%	100%	-	
Max. Fan speed during day		F19	38%	100%	100%	
Fan speed setting in manual mode (r12=-1): 0=Stop; 1=Low; 2=Medium; 3=High		F20	0	3	0	
Max Fan speed during night		F22	38%	100%	80%	
Real time clock (RTC)						
Day time start for Day / Night function		t17	0 h	23 h	0 h	
Night time start for Day / Night function		t18	0 h	23 h	0 h	
RTC setting (hours)		t07	0 h	24 h	0 h	
RTC setting (minutes)		t08	0 min	59 min	0 min	
Miscellaneous						
Controller address on Modbus Network		o03	0	240	0	
Software version of the Condensing Unit controller	*	o08	0	9999	-	
Factory reset of Gateway and Condensing Unit controller		o67	0	1	0	
Condensing Unit status for Evaporator control (Injection ON = Master function).	*	u99	1	1	-	
Statistic						
Condensing Unit runtime in 1000 hours		P48	0	999	0	
Compressor runtime in 1000 hours		P49	0	999	0	
Number of HP alarms registered		P51	0	1999	0	
Number of LP alarms registered		P52	0	1999	0	
Number of High discharge alarm registered		P53	0	1999	0	
Service						
Measured High pressure	*	u01	-1,0 bar	250 bar	-	
Status of gateway Digital Input 1 (DI1 = evaporator alarm)	*	u10	0 (OFF)	1 (ON)	-	
Calculated Superheat	*	u21	-10,0 K	50,0 K	-	
Status of gateway Digital Input 2 (DI2 = request from cold room thermostat)	*	u37	0 (OFF)	1 (ON)	-	
Readout of Compressor speed in %	*	u52	0	100	-	
Status of gateway Alarm Relay	*	U62	0 (OFF)	1 (ON)	-	
Measured Gascooler outlet temperature	*	U05	-30.0 °C	150.0 °C	-	
Measured Receiver inlet temperature	*	U07	-100.0 °C	200.0 °C	-	
Measured Receiver pressure (gateway option) - Currently not available	*	U08	-1,0bar	99,0 bar	-	
Converted Receiver pressure (gateway option) - Currently not available	*	U09	-50.0 °C	50.0 °C	-	
Converted High pressure	*	U22	-50.0 °C	100.0 °C	-	
Measured Suction pressure	*	U23	-1,0bar	99,0 bar	-	
Converted Suction pressure	*	U24	-50.0 °C	100.0 °C	-	
Ambient temperature	*	U25	-10.0 °C	100.0 °C	-	
Discharge temperature	*	U26	-10.0 °C	250.0 °C	-	
Suction temperature	*	U27	-10.0 °C	100.0 °C	-	
Low pressure OFF	*	U78	-25.0°C	30.0°C	-	
Low pressure ON	*	U79	-20.0°C	30.0°C	-	
Firmware version for GW ECU	*	U80	0.0	9.99	-	
High pressure valve opening degree OD	*	U91	0%	100%	-	
Receiver pressure valve opening degree OD	*	U92	0%	100%	-	

* Read only

10.1 State transition diagram

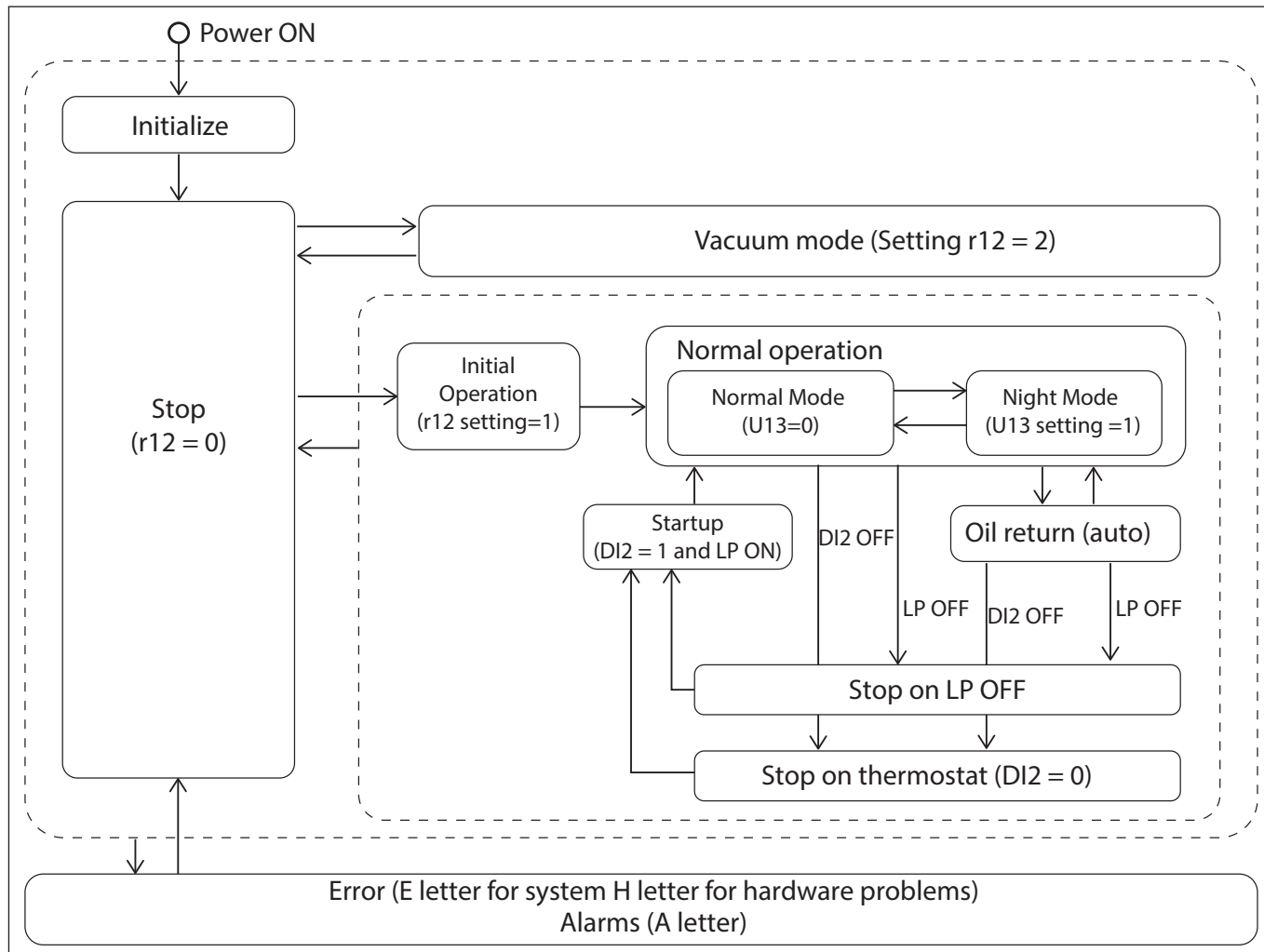

If the communication between controller condensing unit and Gateway controller of the unit is lost, the condensing unit will continue to operate with the set value before the losing communication.
 If communication is lost in STOP status, the Condensing unit cannot be operated unless communication is restored.

10.2 Constraint of cycle operation

For 180 seconds after having stopped cycle operation, the state of operation is held as OFF.

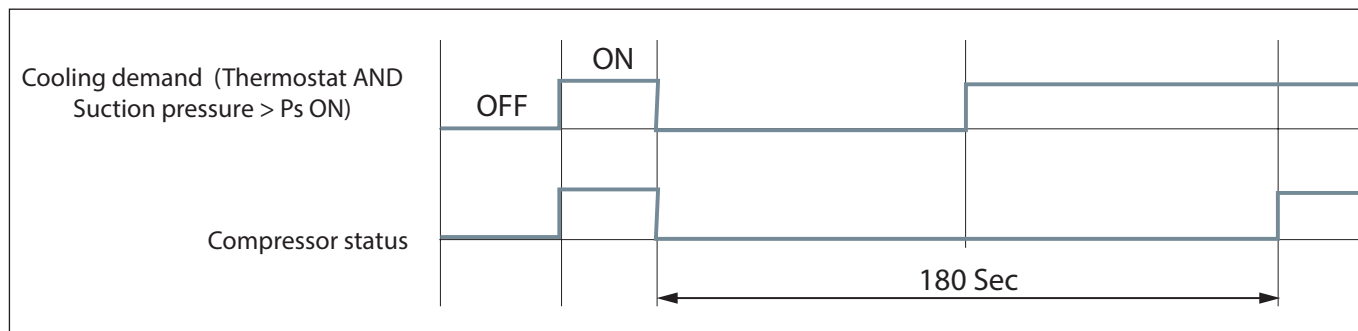

10.3 Control of the cycle operation

When the cycle operation is started, the condensing unit runs such as below.

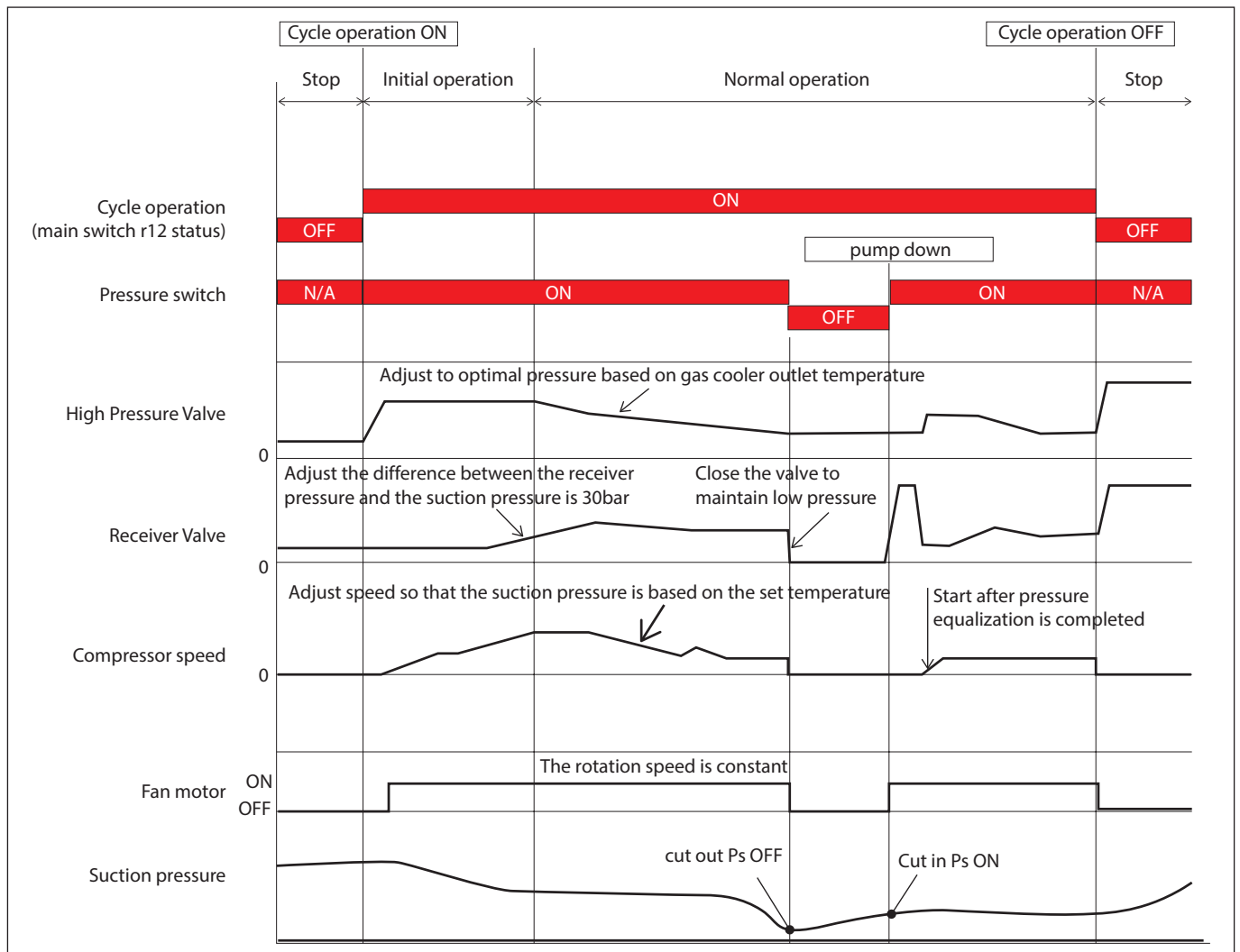

10.4 Normal operation

Compressor operation

Compressor changes speed (refrigeration capacity) based on suction pressure.

If the actual suction pressure is lower than the target set pressure, decrease the compressor speed, and if the actual suction pressure is higher than the target, increase the compressor speed.

If the actual suction pressure is within ± 1 bar of the target low pressure, the compressor speed is maintained.

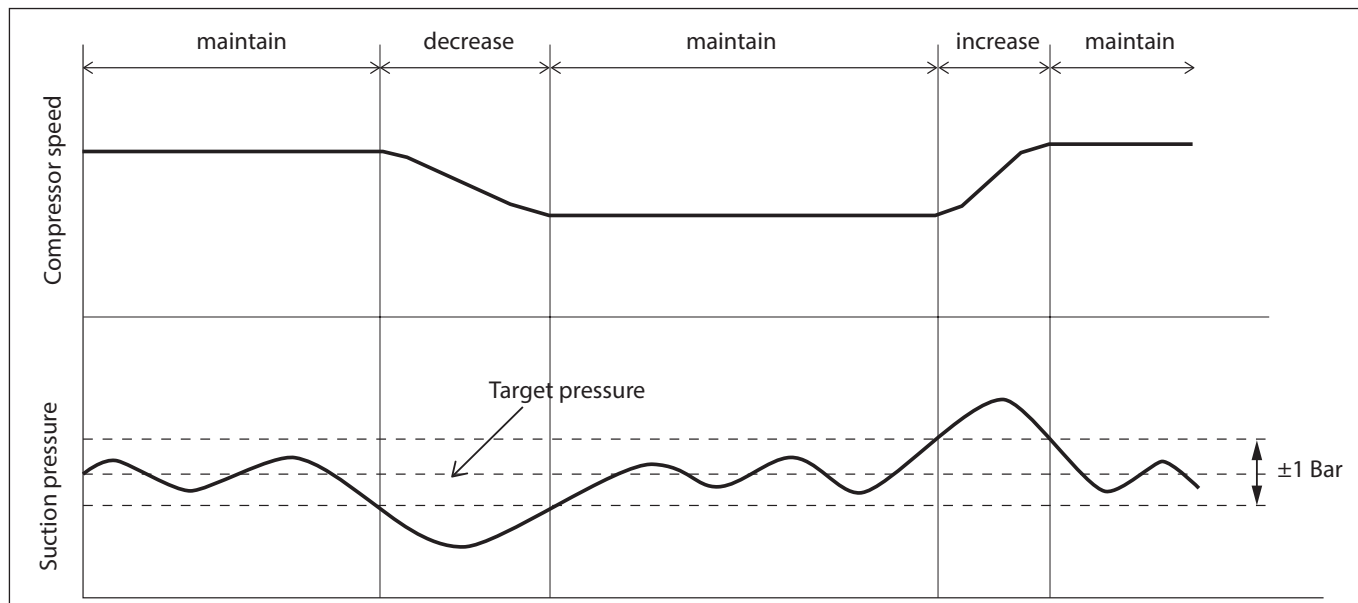

High pressure valve operation

High pressure valve controls high pressure based on the gas cooler outlet temperature.

High pressure target for each temperature is below.

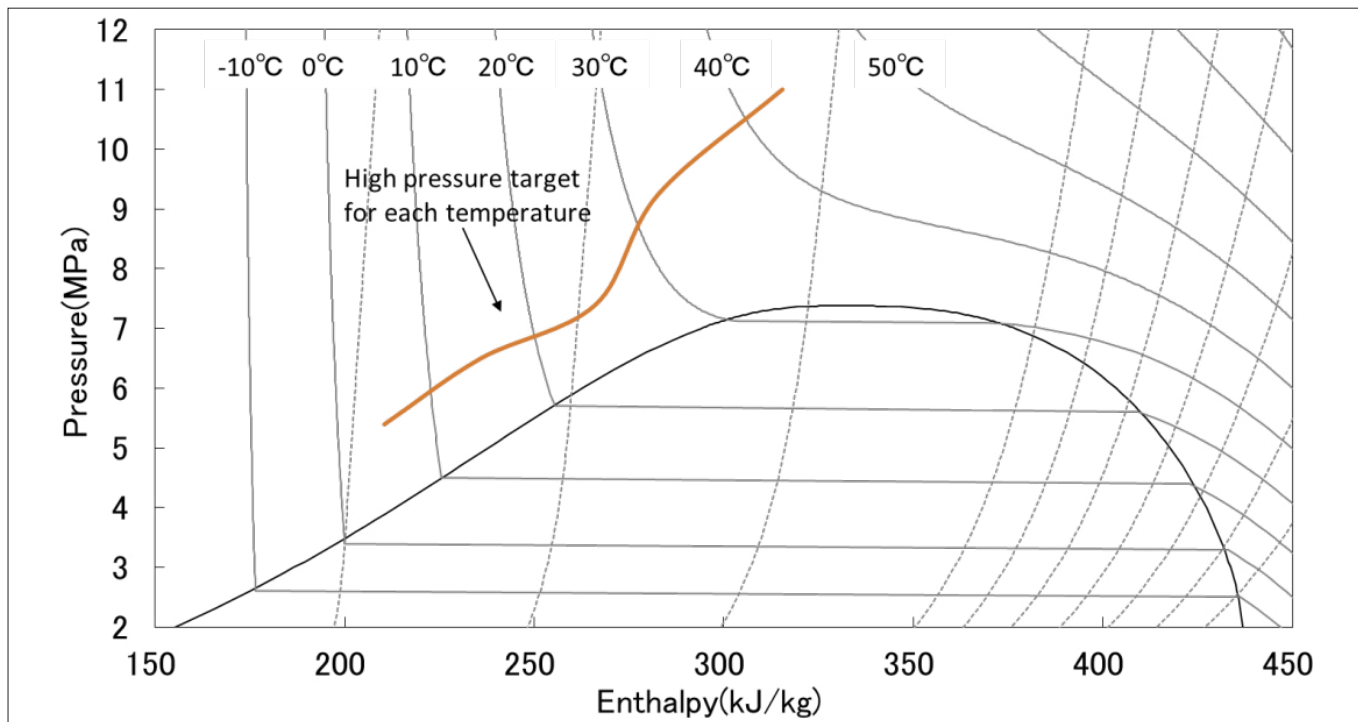

Notes

The gas cooler pressure is optimized to maintain the best COP - For each gas cooler outlet temperature we have an optimal pressure to maximize the COP

To stay within the compressor operating envelope the gas cooler pressure is maintained above 30 bar above suction pressure.

Bypass valve operation

The controller operating the the receiver pressure valve valve tries to maintain a pressure difference between receiver pressure and suction pressure of 30 bar

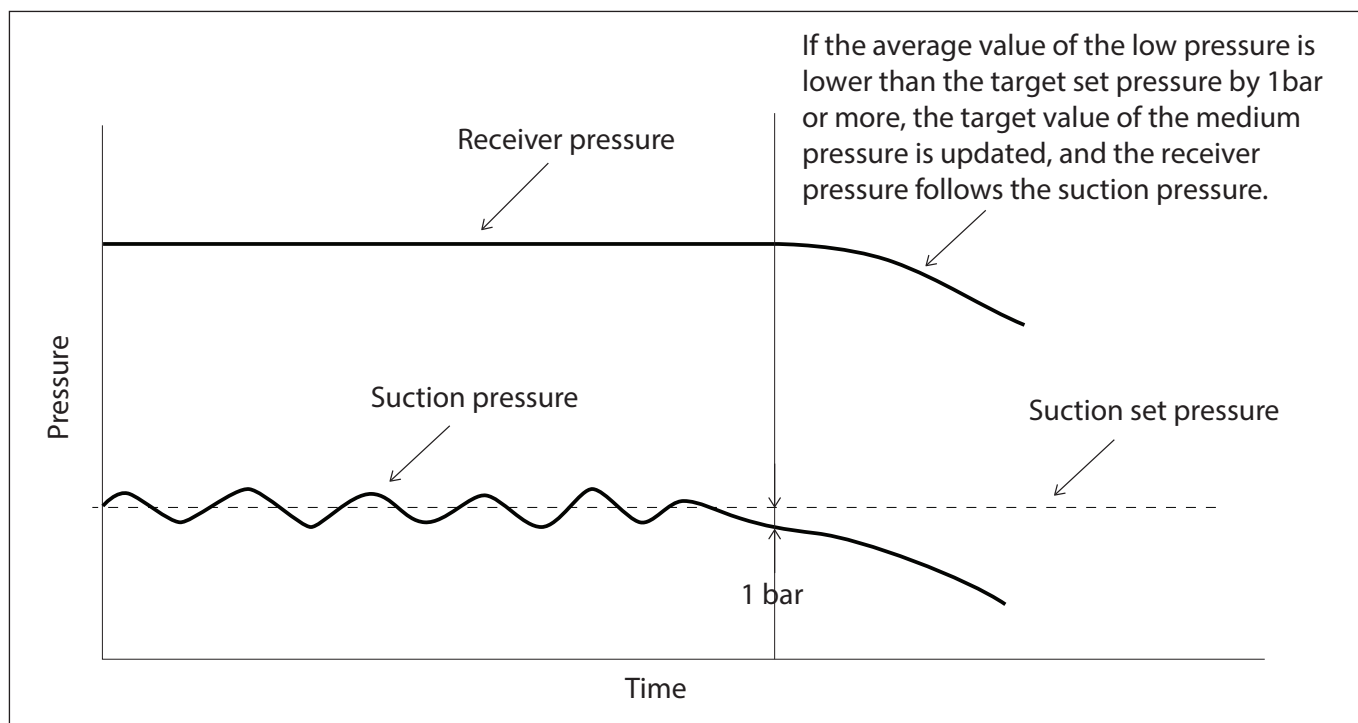
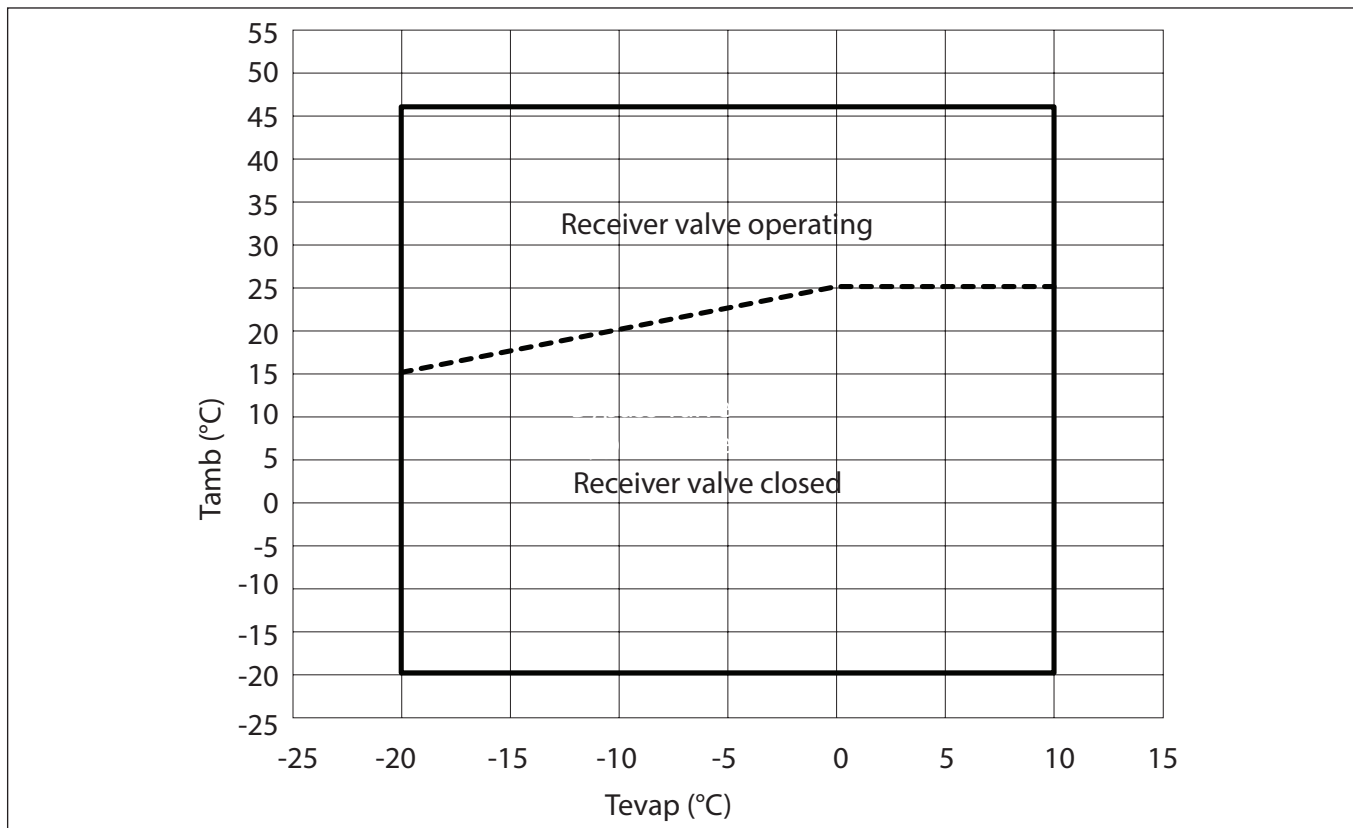

Note:

When $T_{amb} > 25^{\circ}\text{C}$, There will be some time delay to restore cooling capacity. The worst situation is at $T_a = 32^{\circ}\text{C}$, time delay to restore full cooling capacity is around 15 minutes. For higher ambient temperature, the time delay can fall around 10 minutes. Achieving a lower timing is not realistic due to cold room and installation influence.

This unit can operate with all standard commercial refrigeration system which will operate most of the time and will not be impacted by other warming system.

This system is not suitable for applications that require high-precision temperature control (e.g., an air temperature tolerance of $\pm 2\text{K}$). Furthermore, it should not be used in environments where the cold room is utilized for heating or is warmed beyond the unit's specified operating limits.

The condensing unit controller continues to operate even if the receiver pressure is lower than the target value.

The following are possible cases where the receiver pressure is lower than the target value.

Case 1: Low ambient temperature condition

With a fully closed receiver valve, receiver pressure is on the saturated liquid line. Depending on air outside air temperature and gascooler outlet temperature, it will not always be possible to reach the receiver target pressure.

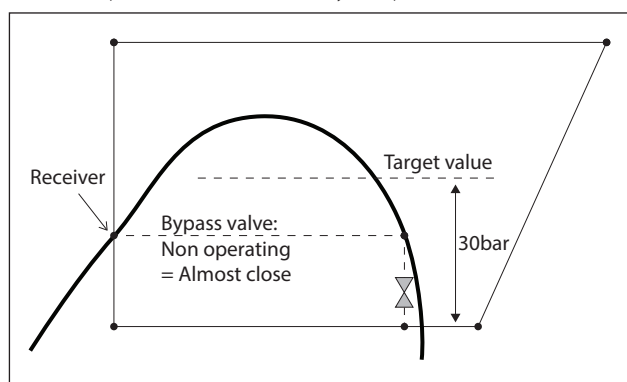

Case 2: Refrigerant shortage

If condensing unit is missing some refrigerant charge, it will not be possible to build up receiver pressure. System will continue to run but cooling capacity will be lower and suction pressure will drop down.

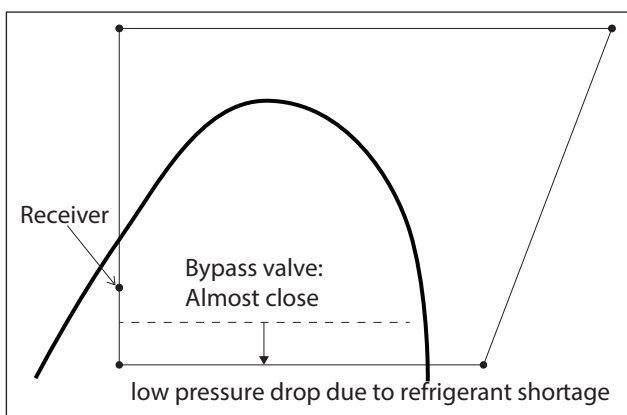

10.5 Compressor OFF/ON

Compressor starts and stops are controlled by both suction pressure (LP ON/OFF) and digital input DI2.

Pressure control mode (Standalone mode)

If digital input DI2 is shunted, there is no communication between the condensing unit and the cold room controller. The condensing unit work in a standalone mode. Only suction pressure commands compressor starts and stops. This mode is also called pressure control mode or pump down mode.

Condensing unit behavior is depict in below drawing. Compressor will stop when suction pressure reaches the LPOFF value. Receiver valve is closed during standstill. The evaporator is pumped down. When suction pressure reach the LPON value, receiver valve open to make a pressure equalization and compressor restart.

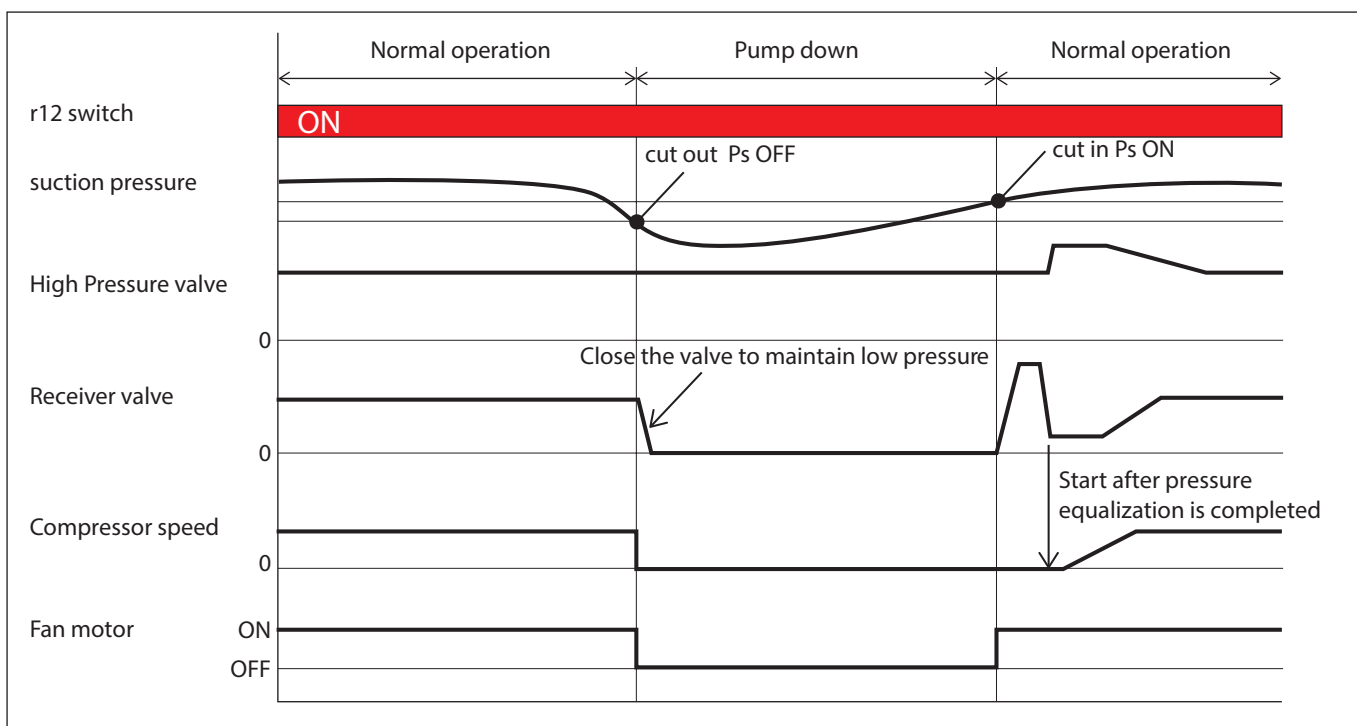

There is 2 ways to specify the LPON/OFF pressure limits :

- 1. Static settings:** LP ON/OFF are defined as static (or absolute) values. Pressures are defined with their corresponding saturated temperature values (parameter c75 and c76).
- 2. Dynamics settings:** LP ON/OFF are specified relative to suction reference T_s and ambient temperature T_a .
 - $LPON = \text{Smallest value of } (T_s + \text{offset}T_s) \text{ and } (T_a + \text{offset}T_a) \text{ and no less than } -20^\circ\text{C}$
 - $LPOFF = LPON + \text{offsetON} \text{ and no less than } -25^\circ\text{C}$

Typical setting could be to fix all offset = -5 K. Compressor will start at a pressure 5 K below T_o and T_a which ever is the smallest. Pump down will be done 5 K below LPON i.e. 10 K below T_o and T_a .

Application Guidelines

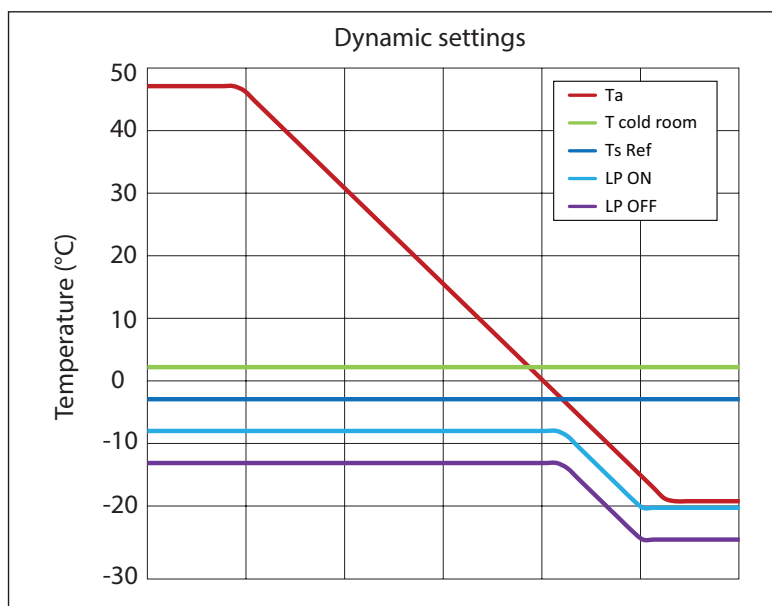

Benefit of Dynamic settings : LP limits will adjust to ambient temperature. Pump down will be lighter in summer when there is no need to pump down to very low pressure. In winter the LPON will always be below T_a , to ensure condensing unit can always restart.

Note

Electronic controller check and modify setting temperature so that $LPOFF < T_s$ and $LPOFF < LPON$

- If $LPOFF > T_s$, then $LPOFF$ is corrected to $LPOFF = T_s - 5\text{ K}$
- If $LPON < LPOFF$, then $LPON$ is set to $LPON = T_s + 5\text{ K}$

Thermostat control mode

Condensing unit digital input DI2 (CNB41-43) need to be connected to cold room thermostat. When relay is closed, condensing unit run in normal operation. When relay is open, condensing unit stops. Receiver valve is fully open during standstill. Pressure is equalized in all the circuit during OFF period.

Summer vacation

In case condensing unit is in pressure control mode, during summer, when cold room is turn OFF a long period of time, condensing unit could still need to start from time to time to cool down the receiver.

To avoid those cycling, we strongly recommend to set condensing main switch $r12 = 0$. This will force bypass valve full open and equalize pressure in all the circuit. Refrigerant charge equation and charge limits guarantee that system pressure will be less than 80 bar as long as cold room temperature does not exceed 38°C.

In case evaporator and suction line are PS 60 bar, best option is to keep system running during summer vacation. Set point can be modified to save energy. It only need to be less than 22°C with some margin (saturated pressure at 22°C is 60 bar).

10.6 Oil return

If the operation under the specified rotation speed (35%) is continued for more than a certain time (20 minutes), the compressor rotation speed will be increased (44%) for 60 seconds. (factory setting)
 Threshold speed and time, oil boost speed and duration can be specified by the user.

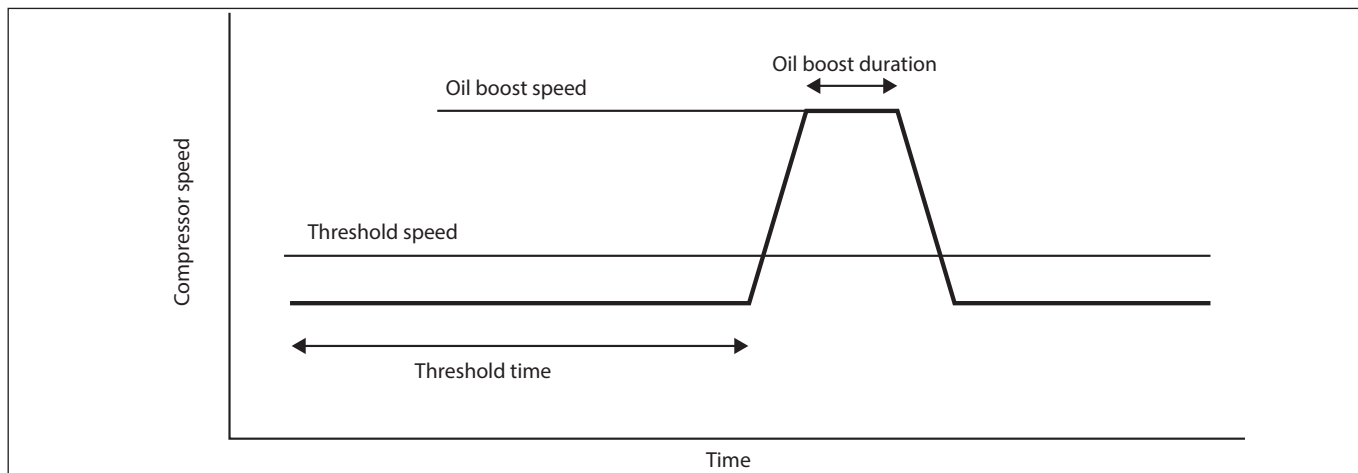

Note

1. If the compressor is stopped (OFF) during oil return operation, the oil return operation will be continued at the next start-up.
2. Compressor speed doesn't increase during emergency pressure or discharge temperature control. Oil return strategy as a lower priority than pressure and discharge temperature control.

10.7 Normal mode / Night mode

The condensing unit switch between Normal (Day) and Night mode depending on time.
 Different maximum compressor speed and fan speed will apply during night and day.
 All parameters, time and speed limits can be defined by the user.

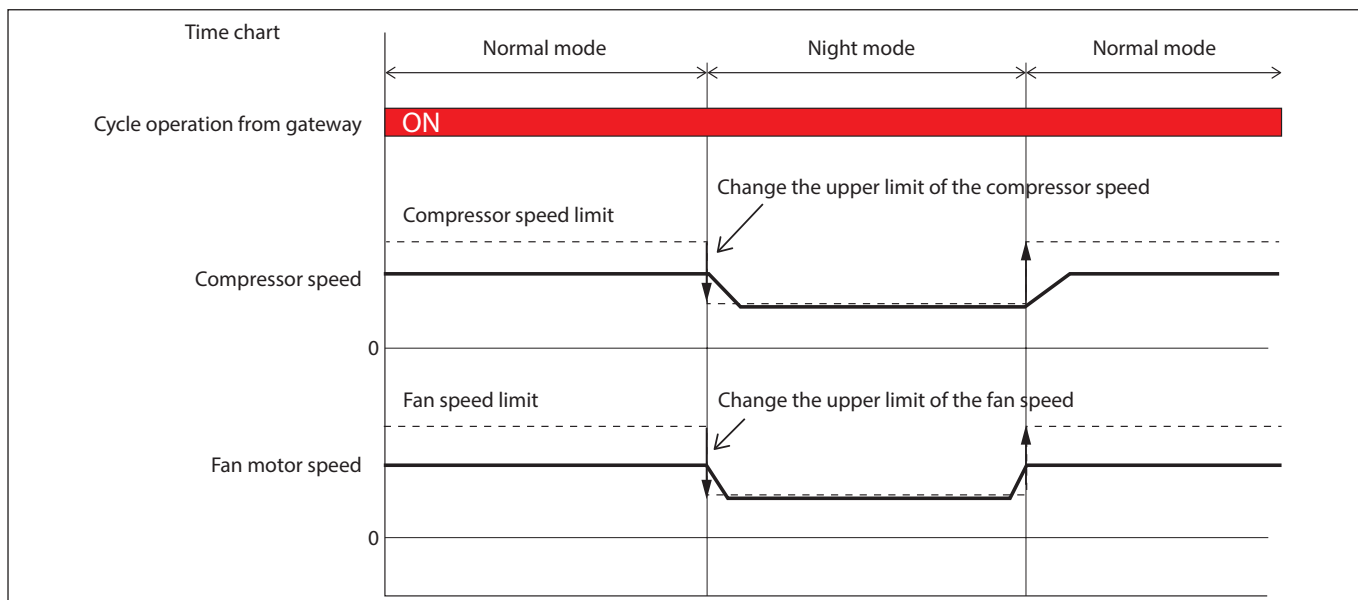

10.8 Vacuum mode

Vacuum mode is set by r12 = 2.
 During vacuum mode, the valves become fully open.

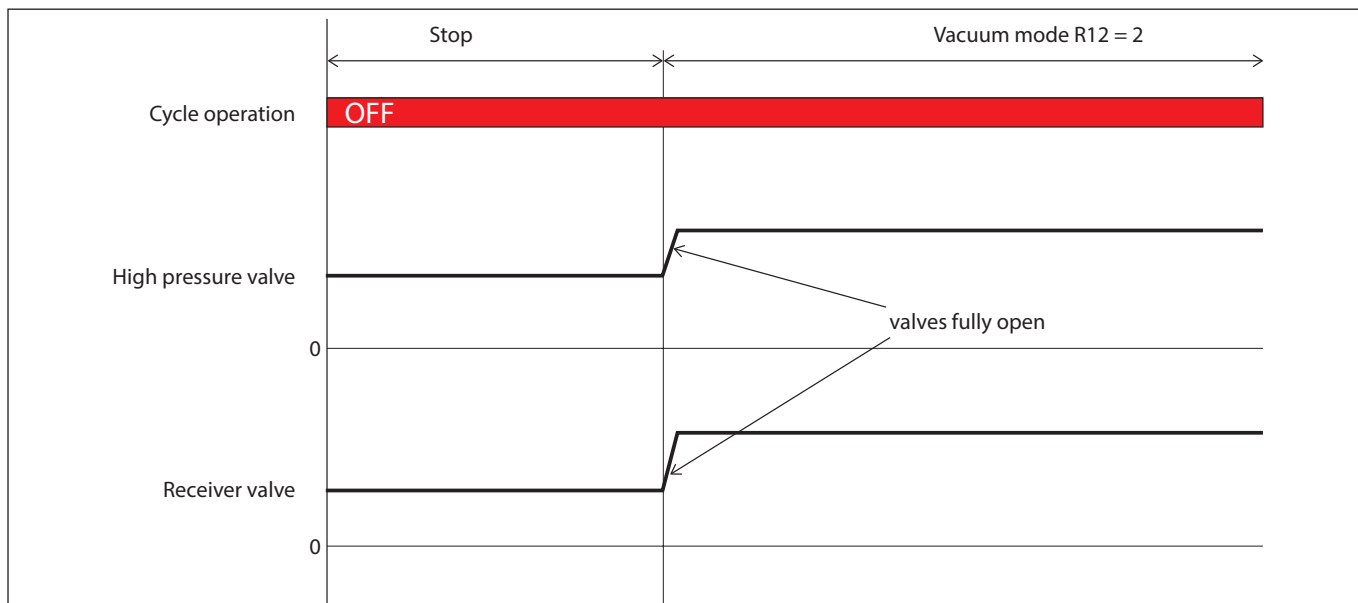

10.9 Fan speed management:

For high ambient running conditions, if the temperature difference between gas cooler outlet and ambient temperature is greater than 10K then fan speed is increased by a step of 50 rpm until the temperature difference is at or below 10K
 When the ambient temperature is below the evaporator setting, fan speed is adjusted to keep the gas cooler outlet pressure 30 bar above suction pressure.

10.10 Pressure management in case of abnormal pressure rising

Control to avoid receiver over pressure during standstill

During standstill receiver pressure is read by the gas cooler pressure transmitter. If receiver pressure rises up to a limit, receiver valve will open and force compressor to restart.

- If valve type is Stepper (o09 = 0): Receiver pressure limit during standstill is $P_{limit} = 76$ bar.
- If valve type is AKV (o09 = 1) : Receiver pressure limit is $P_{limit} = \text{suction pressure} + 30$ bars and less than 76 bar.

Note:

There is a minimum of 180 second time delay between stop and a restart (See 10.2). During that time receiver valve is open and receiver pressure is equalized with the compressor suction.

Control to avoid receiver over pressure during operation

When receiver inlet temperature reach

- 27°C, receiver valve is fully open
- 30°C, compressor slow down
- 33°C, compressor stops.

Control to avoid gas cooler over pressure during operation

Compressor slow down when the gas cooler outlet pressure is higher than 118 Bar.
 Compressor is stopped by pressure switch when the compressor outlet pressure is higher than 140 Bar.

10.11 Error code

The table below show the number of retry times before, showing the error code and stopping the unit. The table show also the time of normal operation that reset the counter of retry numbers. (Temporary stop Interval between retry is 3 minutes)

Error code	Number of retry times	Checking Time
A17	10 times	30 min
A34	10 times	72 s
A96	10 times	30 min
H23	10 times	5 min
H24	10 times	5 min
H25	10 times	5 min
H26	10 times	5 min
H28	10 times	5 min
H29	10 times	5 min
A85	10 times	30 min

Retry operation

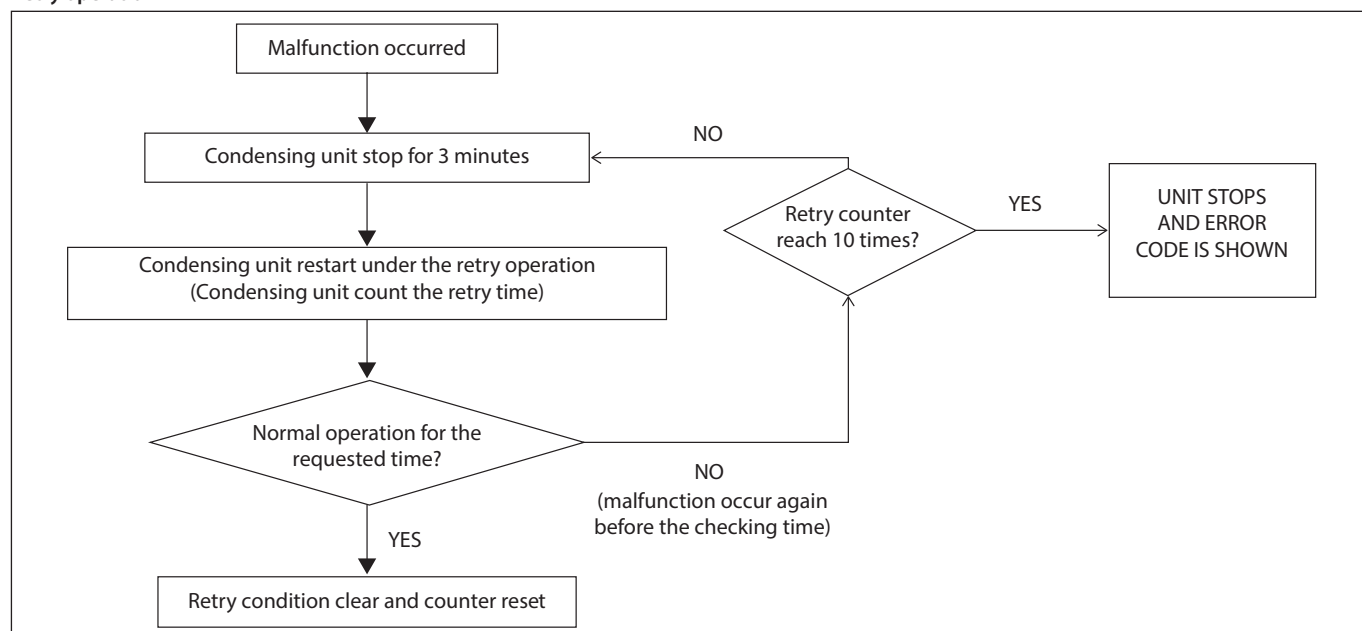

Error code	Content	Detection contents	Detection timing	Self-return	Cycle operating status	Remarks
A2	Low pressure alarm (B2)	Low pressure sensor (B2) are less than 14 Bar.	Stand by	Need reset manually	Stop	Reset error codes after charging
A17	Abnormal high-pressure alarm (B1)	High pressure sensor (B1) detects more than 140 Bar, Srl is continued ten times	Compressor running	Need reset manually	Stop*2	10 –times of retrials starting procedure
E20	Gas cooler outlet thermistor error (R5)	Disconnection (less than or equal -30°C) Short (more over or equal 150 °C)	Power supply ON	Need reset manually	Continue*1	Operation continues using alternative setting values. Or Optyma™ iCO ₂ to suspend its operation.
E33	Suction temperature sensor (R3) error	Disconnection(less than or equal -40°C) Short(more over or equal 100 °C)	Power supply ON	Need reset manually	Continue*1	Optyma™ iCO ₂ to suspend its operation.
E40	Receiver thermistor (R4) error	Disconnection (less than or equal -40°C) Short (more over or equal 100 °C)	Power supply ON	Need reset manually	Stop	Optyma™ iCO ₂ to suspend its operation
E31	Ambient air thermistor (R2) error	Disconnection(less than or equal -40 °C) Short(more over or equal 100°C)	Power supply ON	Need reset manually	Stop	Optyma™ iCO ₂ to suspend its operation
E32	Discharge thermistor (R1) error	Disconnection(less than or equal -40 °C) Short(more over or equal 250°C)	Power supply ON	Need reset manually	Stop	Optyma™ iCO ₂ to suspend its operation
A34	Gas cooler fan motor (M2) error	Rotor pulse signals is detected continuously less than or equal 100rpm for 60 seconds	Compressor running	Need reset manually	Stop*2	10 –times of retrials
E39	Low pressure sensor (B2) error (suction)	Disconnection (less than or equal 0.0 Bar) Short(more over or equal 112 Bar)	Power supply ON (without vacuum mode)	Need reset manually	Stop	Optyma™ iCO ₂ to suspend its operation
A96	Discharge temperature (R1) alarm	Discharge temp. thermistor detects more than or equal 138°C for 5 seconds.	Compressor running	Need reset manually	Stop*2	10 –times of retrials
H23	Optyma™ iCO ₂ Electronic controller error	Unit Controller / Inverter error code (internal)	Compressor running	Need reset manually	Stop*2	10 –times of retrials
H24		Electrical circuit failure on the inverter				
H25		Motor current sensor failure on inverter				
H26		Input current sensor failure on inverter				
H27		Motor current error (phase open)				
H28		Other error for compressor or inverter				
H29		Anbornamity, compressor speed not increasing				
E42	Pressure sensors (B1) error or refrigerant shortage	Disconnection (more over or equal 219.5 Bar) Short (less than or equal 0.0 Bar)	Power supply ON (without vacuum mode)	Need reset manually	Stop	Optyma™ iCO ₂ to suspend its operation
A85	abnormality medium pressure	Receiver thermistor (R4) detects more than 78 Bar in pressure conversion value	Compressor running	Need reset manually	Stop*2	10 –times of retrials
A97	High pressure sensor safety switch (B3) alarm	Mechanical high pressure safety switch (B3) disconnect contactor & compressor	Compressor running	Need reset manually	Stop	
A45	Main Switch OFF	Main switch par. r12 OFF	Stand by	Need reset manually	Stop	

*1 When the following sensors fail, the Optyma™ iCO₂ continues to operate using another sensor.

- GC outlet thermistor → Ambient air thermistor
: Except operating out of the envelope map
- Suction thermistor → Low pressure sensor
(Convert to temperature)

Optyma™ iCO₂ stops when two or more errors are occurred at the same time.

*2 Optyma™ iCO₂ to suspend its operation when error continues after 10 –times of retrials; after this, sending error code.

ATTENTION: Do not reach your hands into the Optyma™ iCO₂ unit because there is a possibility of electric shock.

Note (1): Electronic controller is Electronic controller + driver

Note (2): For the abbreviations R1, R2, R3, etc., please see appendix material

Error code A2 - Low pressure alarm (sensor B2)

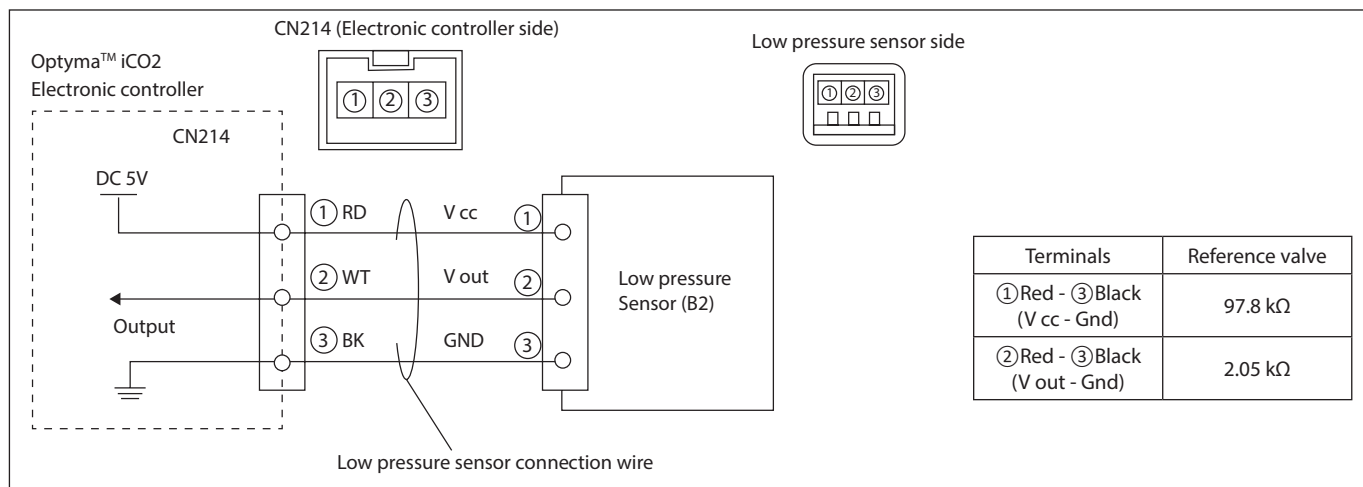

1. Detection condition	Diagnosis flow	Cause (action taken)
Low pressure are less than 14 Bar for 10 s.	<p>1. To check whether if there is disconnection/abnormal swaging / moisture ingress/wire jamming of the connector/service valves closed by visual check</p> <p>2. Conduct diagnosis per following flow chart only when there is no abnormal found by visual check.</p> <pre> graph TD Start([Correct quantity of gas?]) -- YES --> Leak{Leak test system?} Start -- NO --> Leak Leak -- YES --> Repair[Repair leak] Leak -- NO --> Cancel[Cancel the error codes and re-start Optyma™ iCO2 unit. For reset all the alarms, switch off CDU unit, wait five minutes and switch on the unit.] Cancel --> Recur{Same Error code shows up again?} Recur -- YES --> Power[Turn off mains power (230V AC) to the system (before open maintenance door), then check followings after 5 min. •Corrosion of Optyma™ iCO2 Electronic controller] Recur -- NO --> Wire{Wire snapping or short circuit found?} Power --> Corrosion{Corrosion found?} Corrosion -- YES --> Replace[Replace failure parts] Corrosion -- NO --> Wire Wire -- YES --> Sensor[Low pressure sensor connecting wire (replace connecting wire)] Wire -- NO --> Measure[Measure inter-terminal (①-③, ②-③) resistances for the pressure sensor] Measure --> Short{Wire snapping or short circuit to a part of terminals?} Short -- YES --> Sensor Short -- NO --> ReplaceCtrl[Replace Optyma™ iCO2 Electronic controller, then reset error codes. Restart Optyma™ iCO2 unit by turning on and of the unit] ReplaceCtrl --> Operates{Operates normally?} Operates -- YES --> Complete[Optyma™ iCO2 Electronic controller failure (Repair complete)] Operates -- NO --> Watch[Watch the consequence] </pre>	<p>Check if there is any leak and correct the refrigerant charge. (Reset error codes after charging)</p> <p>Repair leak</p> <p>Replace failure parts</p> <p>Low pressure sensor connecting wire (replace connecting wire)</p> <p>Pressure sensor failure (Replace pressure sensor)</p> <p>Optyma™ iCO₂ Electronic controller failure (Repair complete)</p> <p>Refrigerant leak, blockage(Identify leak portion, and replace parts)</p> <p>Watch the consequence</p>
2. Detection timing	<p>When a cycle operation signal from GW change OFF to ON</p>	
3. Estimated causes	<p>1. Refrigerant not charged or leak</p> <p>2. Low pressure sensor</p> <p>If the problem cannot be solved by checking only Optyma™ iCO₂, there is a possibility of leakage or blockage in the Evaporator or the piping between a Evaporator and Optyma™ iCO₂, so please check that as well.</p>	

Error code A17 - Abnormal high-pressure alarm (sensor B1)

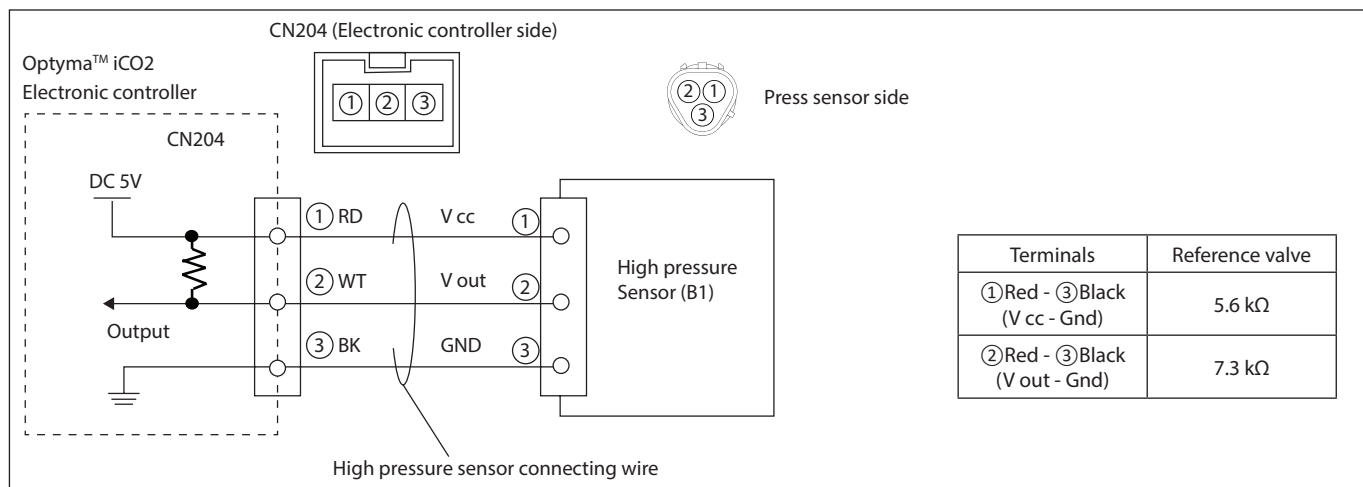

1. Detection condition	Diagnosis flow	Cause (action taken)
High pressure sensor (B1) transmitter more than 140 Bar (0.5 s)	<p>1. To check whether if there is disconnection/abnormal swaging / moisture ingress/wire jamming of the connector/service valves closed / gas cooler blockage (air side) by visual check</p> <p>2. To check whether if there is pipes distortion, blockage/ filter blockage</p> <p>3. Conduct diagnosis per following flow chart only when there is no abnormal found by visual check.</p> <pre> graph TD A[Measure resistances for a pressure sensor (B1)] --> B{Broken Wire or short circuit?} B -- YES --> C[High pressure sensor (B1) or wire failure (Replace failure parts)] B -- NO --> D[Switch off CDU unit, wait five minutes and switch on the unit, then confirm following points: • Corrosion of Optyma™ iCO2 Electronic controller] D --> E{Corrosion? (CN204 section)} E -- YES --> F[Replace abnormal parts] E -- NO --> G[Cancel the error codes and re-start Optyma™ iCO2 unit. For reset all the alarms, switch off CDU unit, wait five minutes and switch on the unit.] G --> H{"Clang-clang" noise? (stepper valve)} H -- NO --> I[To Check and fix Expansion valve or Bypass valve] H -- YES --> J{Operates normally?} J -- YES --> K[Watch the consequence] J -- NO --> L[Replace Optyma™ iCO2 Electronic controller, then re-start Optyma™ iCO2] L --> M{Operates normally?} M -- YES --> N[Optyma™ iCO2 Electronic controller failure (Repair complete)] M -- NO --> O[Optyma™ iCO2 failure (blockage)] </pre>	
2. Detection timing Compressor running		
3. Estimated causes		
<p>1. High pressure sensor</p> <p>2. Fan motor</p> <p>3. Optyma™ iCO₂ Electronic controller</p> <p>4. Expansion valve</p> <p>5. CO₂ cycle</p> <p>6. Gas cooler</p>		
4. Action when error occurred		
<p>Optyma™ iCO₂ to suspend its operation if abnormal continues after 10 times of retrial</p> <p>Note Retrial control logic: Re-start operation after 3 min. of operation stop.</p>	<p>If the problem cannot be solved by checking only Optyma™ iCO₂, there is a possibility of leakage or blockage in the Evaporator or the piping between a Evaporator and Optyma™ iCO₂, so please check that as well.</p>	

Error code E20 - Gascooler outlet thermistor error (R5)

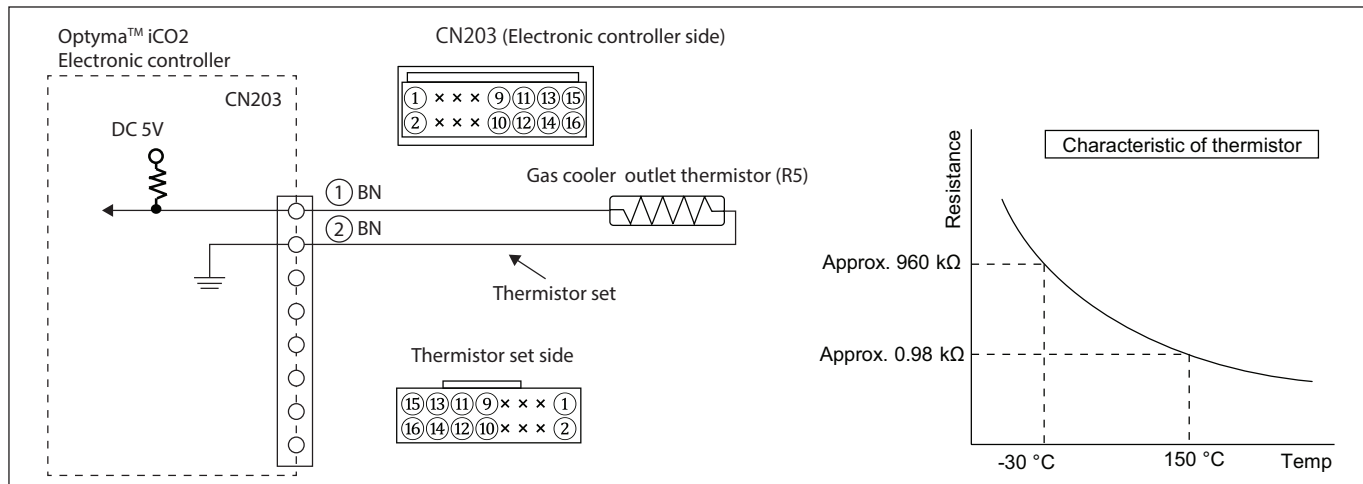

1. Detection condition	Diagnosis flow	Cause (action taken)
1. Wire snapping (- 30 °C or lower to last for 10 s) 2. Short circuit (150 °C or higher to last for 10 s)	1. To check whether if there is disconnection/abnormal swaging / moisture ingress/wire jamming of the connector by visual check 2. Conduct diagnosis per following flow chart only when there is no abnormal found by visual check.	
	<div style="border: 1px solid black; padding: 5px; width: fit-content; margin: 0 auto;">ATTENTION: Turn off mains power (230V AC) to the system</div> <div style="border: 1px solid black; padding: 5px; width: fit-content; margin: 5px auto;">Disconnect CN203, Measure resistance of the Gas cooler outlet thermistor by measuring resistor between terminal ① and ②</div> <div style="text-align: center; margin: 10px 0;"> </div> <div style="display: flex; justify-content: space-between; margin: 0 100px;"> <div style="text-align: center;">NO</div> <div style="text-align: center;">YES</div> </div> <div style="text-align: center; margin: 10px 0;"> </div> <div style="display: flex; justify-content: space-between; margin: 0 100px;"> <div style="text-align: center;">NO</div> <div style="text-align: center;">YES</div> </div> <div style="border: 1px solid black; padding: 5px; width: fit-content; margin: 10px auto;">Re-connect the connector and reconfirm thermistor temp by the maintenance mode.</div> <div style="text-align: center; margin: 10px 0;"> </div> <div style="display: flex; justify-content: space-between; margin: 0 100px;"> <div style="text-align: center;">Normal</div> <div style="text-align: center;">Abnormal</div> </div>	Gas cooler Outlet thermistor broken (Replace the thermistor)
2. Detection timing Power supply ON		Gas cooler Outlet thermistor Short circuit (Replace thermistor)
3. Estimated causes 1. Thermistor 2. Connector connection failure. wire snapping, etc. 3. Optyma™ iCO ₂ Electronic controller		Optyma™ iCO ₂ Electronic controller failure (Replace Optyma™ iCO ₂ Electronic controller)
4. Action when error occurred Operation continues using alternative setting values. Or Optyma™ iCO ₂ to suspend its operation.	Note Resistance value checking process: (Hold a thermistor by hand) 1. Read resistance value 2. Compare temp between values on the resistance-temp table and measured value. (Criteria: If there is a gap for 10 % or more, it is judged NG. Replace the thermistor)	Repair complete (Watch the consequence)

Error code E33 - Suction temperature sensor (R3) error

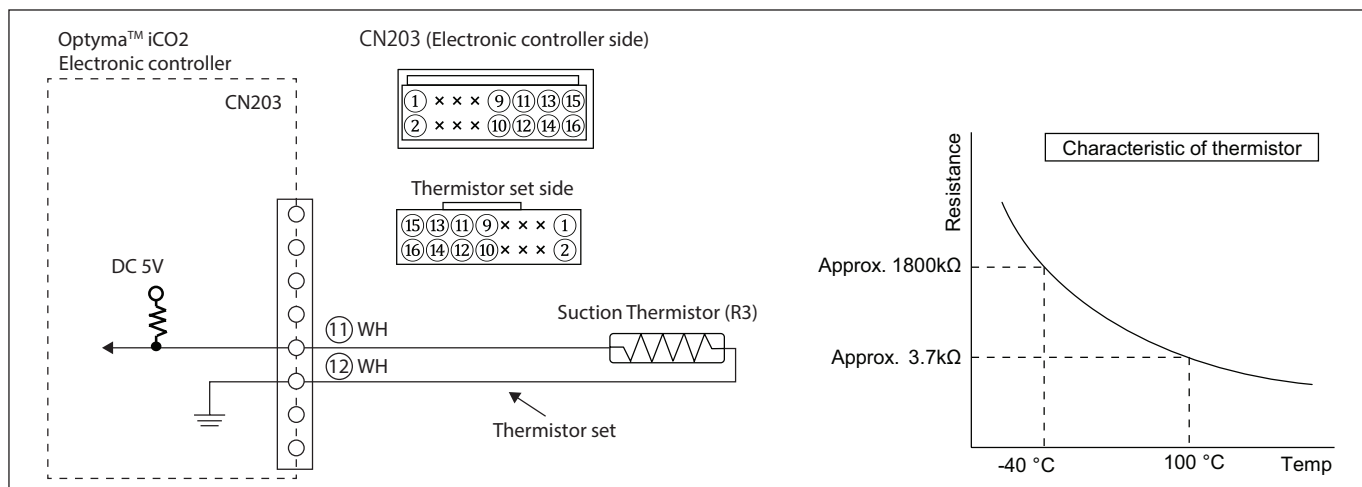

1. Detection condition	Diagnosis flow	Cause (action taken)
1. Wire snapping (- 30 °C or lower to last for 10 s) 2. Short circuit (150 °C or higher to last for 10 s)	1. To check whether if there is disconnection/abnormal swaging / moisture ingress/wire jamming of the connector by visual check 2. Conduct diagnosis per following flow chart only when there is no abnormal found by visual check.	
2. Detection timing Power supply ON	<p style="text-align: center;">ATTENTION: Turn off mains power (230V AC) to the system</p> <p style="text-align: center;">Disconnect CN203. measure the resistance of the suction thermistor by measuring terminals between ⑪-⑫</p> <p style="text-align: center;">Approx. 1800 kΩ or higher?</p> <p style="text-align: center;">NO</p> <p style="text-align: center;">Approx. 3.7 kΩ or lower?</p> <p style="text-align: center;">NO</p> <p style="text-align: center;">Re-connect connectors, and reconfirm thermistor temp by maintenance mode</p> <p style="text-align: center;">Normal value, between 1800 kΩ±3.7 kΩ ?</p> <p style="text-align: center;">Normal</p>	YES Suction Thermistor broken (Replace the thermistor)
3. Estimated causes 1. Thermistor 2. Connector connection failure. wire snapping, etc. 3. Optyma™ iCO ₂ Electronic controller	YES Suction Thermistor Short circuit (Replace thermistor)	
4. Action when error occurred Operation continues using alternative setting values. Or Optyma™ iCO ₂ to suspend its operation.	<p>Note Resistance value checking process:</p> (Hold a thermistor by hand) 1. Read resistance value 2. Compare temp between values on the resistance-temp table and measured value. (Criteria: If there is a gap for 10 % or more, it is judged NG. Replace the thermistor)	Abnormal Optyma™ iCO ₂ Electronic failure (Replace Optyma™ iCO ₂ Electronic controller)
		Repair complete (Watch the consequence)

Error code E40 - Receiver thermistor error (R4)

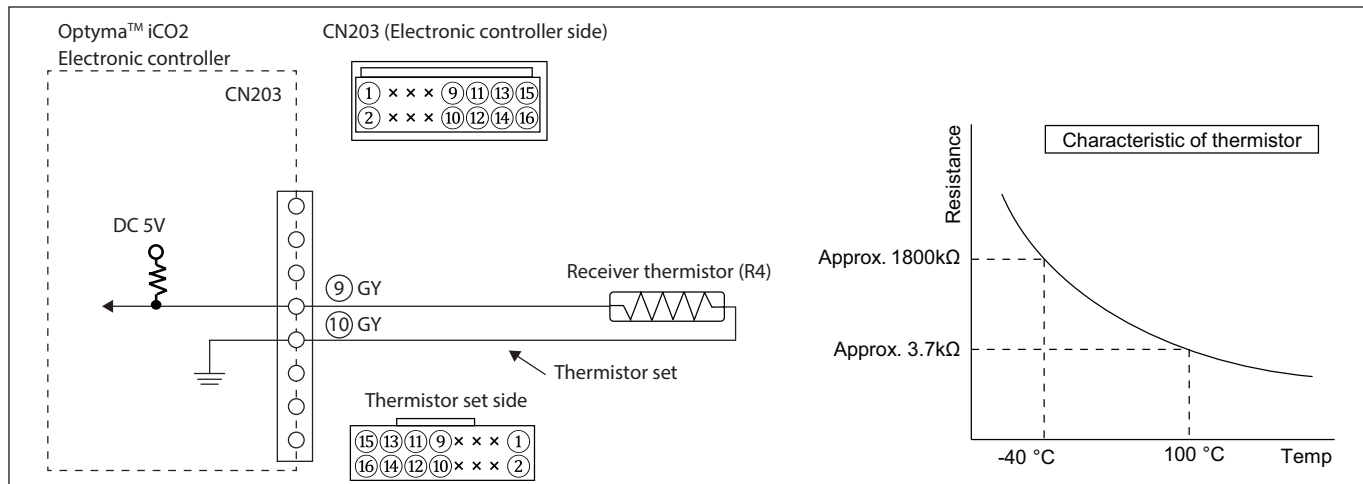

1. Detection condition	Diagnosis flow	Cause (action taken)	
1. Wire snapping (- 40 °C or lower to last for 10 s) 2. Short circuit (100 °C or higher to last for 10 s)	1. To check whether if there is disconnection/abnormal swaging / moisture ingress/wire jamming of the connector by visual check 2. Conduct diagnosis per following flow chart only when there is no abnormal found by visual check.		
2. Detection timing	<div style="border: 1px solid black; padding: 5px; margin-bottom: 5px;"> ATTENTION: Turn off mains power (230V AC) to the system </div> <div style="border: 1px solid black; padding: 5px; margin-bottom: 5px;"> Disconnect CN203, measure the resistance of the receiver thermistor by measuring terminals between ⑨-⑩ </div> <div style="text-align: center;"> </div> <div style="text-align: center;"> </div> <div style="border: 1px solid black; padding: 5px; margin-bottom: 5px; text-align: center;"> Re-connect connectors, and reconfirm thermistor temp by maintenance mode </div> <div style="text-align: center;"> </div>	Receiver thermistor broken (Replace the thermistor)	
Power supply ON			Receiver thermistor Short circuit (Replace thermistor)
3. Estimated causes			Optyma™ iCO ₂ Electronic failure (Replace Optyma™ iCO ₂ Electronic controller)
4. Action when error occurred		Note Resistance value checking process: (Hold a thermistor by hand) 1. Read resistance value 2. Compare temp between values on the resistance-temp table and measured value. (Criteria: If there is a gap for 10 % or more, it is judged NG. Replace the thermistor)	Repair complete (Watch the consequence)
Optyma™ iCO ₂ to suspend its operation.			

Error code E31 - Ambient air thermistor error (R2)

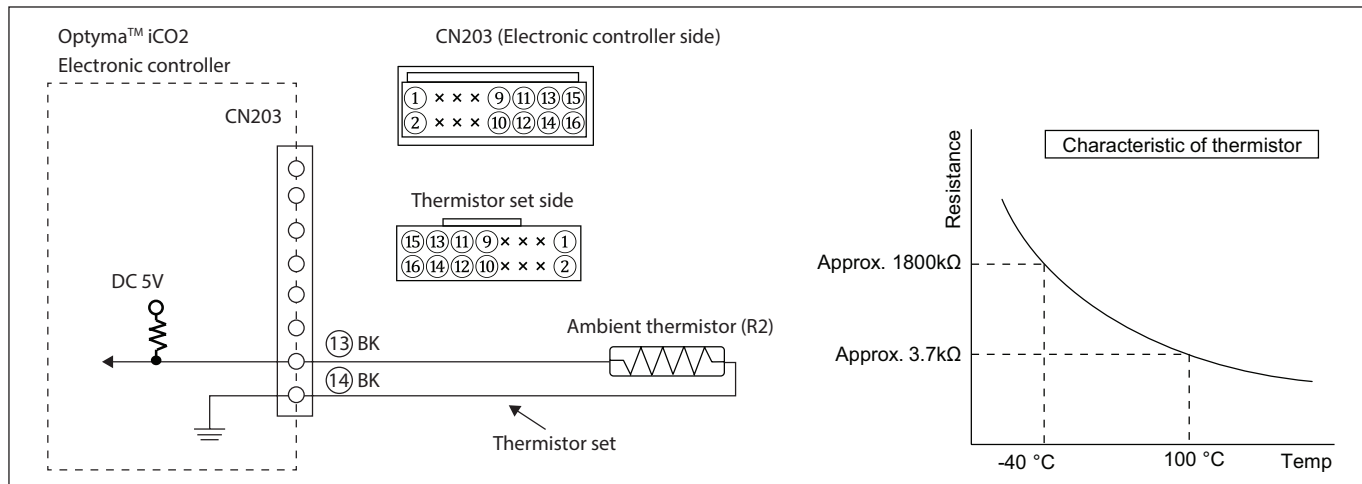

1. Detection condition	Diagnosis flow	Cause (action taken)	
1. Wire snapping (- 40 °C or lower to last for 10 s) 2. Short circuit (100 °C or higher to last for 10 s)	1. To check whether if there is disconnection/abnormal swaging / moisture ingress/wire jamming of the connector by visual check 2. Conduct diagnosis per following flow chart only when there is no abnormal found by visual check.		
2. Detection timing	<div style="border: 1px solid black; padding: 5px; margin-bottom: 5px;">ATTENTION: Turn off mains power (230V AC) to the system</div> <div style="border: 1px solid black; padding: 5px; margin-bottom: 5px;">Disconnect CN203, measure the resistance of ambient air thermistor by measuring terminals between ⑬-⑭</div> <div style="text-align: center;"> </div> <div style="text-align: center;"> </div> <div style="border: 1px solid black; padding: 5px; margin-bottom: 5px; text-align: center;">Re-connect connectors, and reconfirm thermistor temp by maintenance mode</div> <div style="text-align: center;"> </div>	Ambient air thermistor broken (Replace the thermistor)	
Power supply ON			Ambient air thermistor Short circuit (Replace thermistor)
3. Estimated causes			Optyma™ iCO ₂ Electronic failure (Replace Optyma™ iCO ₂ Electronic controller)
1. Thermistor 2. Connector connecting error, Snapping of the wire 3. Optyma™ iCO ₂ Electronic controller		Note Resistance value checking process: (Hold a thermistor by hand)	Repair complete (Watch the consequence)
4. Action when error occurred	1. Read resistance value 2. Compare temp between values on the resistance-temp table and measured value. (Criteria: If there is a gap for 10 % or more, it is judged NG. Replace the thermistor)		
Optyma™ iCO ₂ to suspend its operation.			

Error code E32 - Discharge thermistor (R1) error

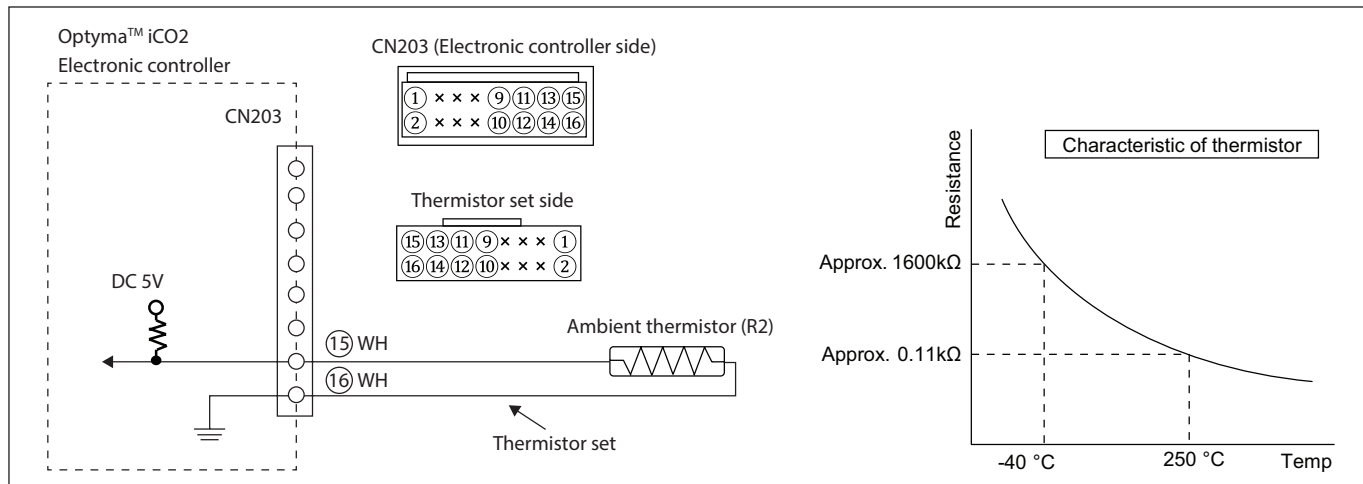

1. Detection condition	Diagnosis flow	Cause (action taken)
1. Wire snapping (- 40 °C or lower to last for 10 s) 2. Short circuit (200 °C or higher to last for 10 s)	1. To check whether if there is disconnection/abnormal swaging / moisture ingress/wire jamming of the connector by visual check 2. Conduct diagnosis per following flow chart only when there is no abnormal found by visual check.	
2. Detection timing Power supply ON	<p style="text-align: center;">ATTENTION: Turn off mains power (230V AC) to the system</p> <p style="text-align: center;">CN203 measure the resistance of the discharge thermistor by measuring terminals between ⑮-⑯</p> <p style="text-align: center;">Approx. 1600 kΩ or higher?</p> <p style="text-align: center;">YES → Discharge thermistor broken (Replace the thermistor)</p> <p style="text-align: center;">NO</p> <p style="text-align: center;">Approx. 0.11 kΩ or lower?</p> <p style="text-align: center;">YES → Discharge temp thermistor Short circuit (Replace thermistor)</p> <p style="text-align: center;">NO</p> <p style="text-align: center;">Re-connect connectors, and reconfirm thermistor temp by maintenance mode</p> <p style="text-align: center;">Normal value, between 1600 kΩ-0.11 kΩ ?</p> <p style="text-align: center;">Abnormal → Optyma™ iCO₂ Electronic failure (Replace Optyma™ iCO₂ Electronic controller)</p> <p style="text-align: center;">Normal → Repair complete (Watch the consequence)</p>	
3. Estimated causes 1. Thermistor 2. Connector connecting error, Snapping of the wire 3. Optyma™ iCO ₂ Electronic controller	<p>Note Resistance value checking process:</p> <p>(Hold a thermistor by hand)</p> <p>1. Read resistance value</p> <p>2. Compare temp between values on the resistance-temp table and measured value.</p> <p>(Criteria: If there is a gap for 10 % or more, it is judged NG. Replace the thermistor)</p>	
4. Action when error occurred Optyma™ iCO ₂ to suspend its operation.		

Error code A34 - Fan motor error (M2)

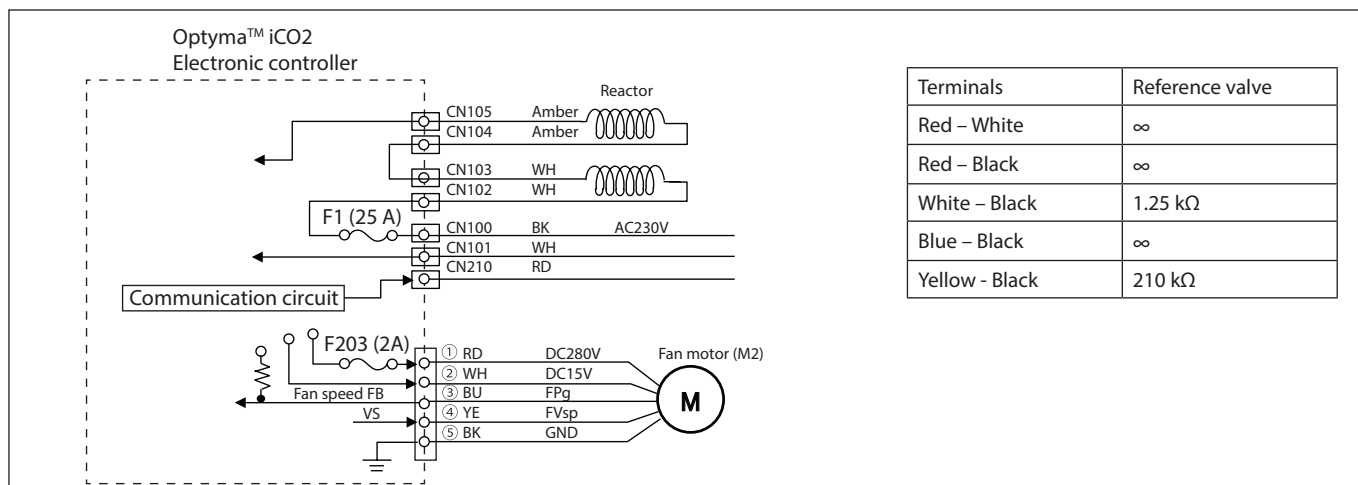

1. Detection condition	Diagnosis flow	Cause (action taken)
<p>Rotor pulse signals is detected continuously less than or equal 100 rpm for 60 seconds</p>	<p>1. To check whether if there is disconnection/abnormal swaging / moisture ingression/wire jamming of the connector by visual check</p> <p>2. To check if there is any foreign matter getting caught in the fan blade</p> <p>3. Conduct diagnosis per following flow chart only when there is no abnormal found by visual check.</p> <div style="border: 1px solid black; padding: 5px; margin: 10px 0;"> <p>Turn off mains power (230V AC) to the system, then check the fuse (F203, F204, F1 in the CDU ECU) on the fan motor circuit after 5 minutes.</p> </div> <p style="text-align: center;">Fuse is burned out?</p> <p style="text-align: right;">YES → Replace the fuse</p> <p style="text-align: center;">NO</p> <div style="border: 1px solid black; padding: 5px; margin: 10px 0;"> <p>Measure the resistance of the fan motor</p> </div> <p style="text-align: center;">Normal value ?</p> <p style="text-align: right;">Abnormal</p> <p style="text-align: center;">Normal</p> <div style="border: 1px solid black; padding: 5px; margin: 10px 0;"> <p>By turning on and off the power supply, cancel the error codes and re-start Optyma™ iCO2 unit. Measure the actual fan speed.</p> </div> <p style="text-align: center;">100 rpm Or lower?</p> <p style="text-align: right;">YES</p> <p style="text-align: center;">NO</p>	<p>Fan motor failure (Replace fan motor)</p> <p>* If after replace fan motor, this one does not work, It is suggested to replace also the Electronic controller.</p> <p>Fan motor failure (Replace fan motor)</p> <p>Repair complete (Watch the consequence)</p>
<p>2. Detection timing</p> <p>Fan motor is ON</p>		
<p>3. Estimated causes</p> <p>Fans do not turn due to vegetation, freezing, snow, etc.</p> <p>1. Fan motor</p> <p>2. Optyma™ iCO2 Electronic controller</p> <p>3. Connector connection failure. wire snapping, etc.</p>		
<p>4. Action when error occurred</p> <p>Optyma™ iCO2 to suspend its operation when error continues after 10 –times of retrials.</p> <p><Retrial control> Return back to normal operation after Optyma™ iCO2 to be suspended for 3 min.</p>		

Error code E39 - Low pressure sensor (B2) error (suction)

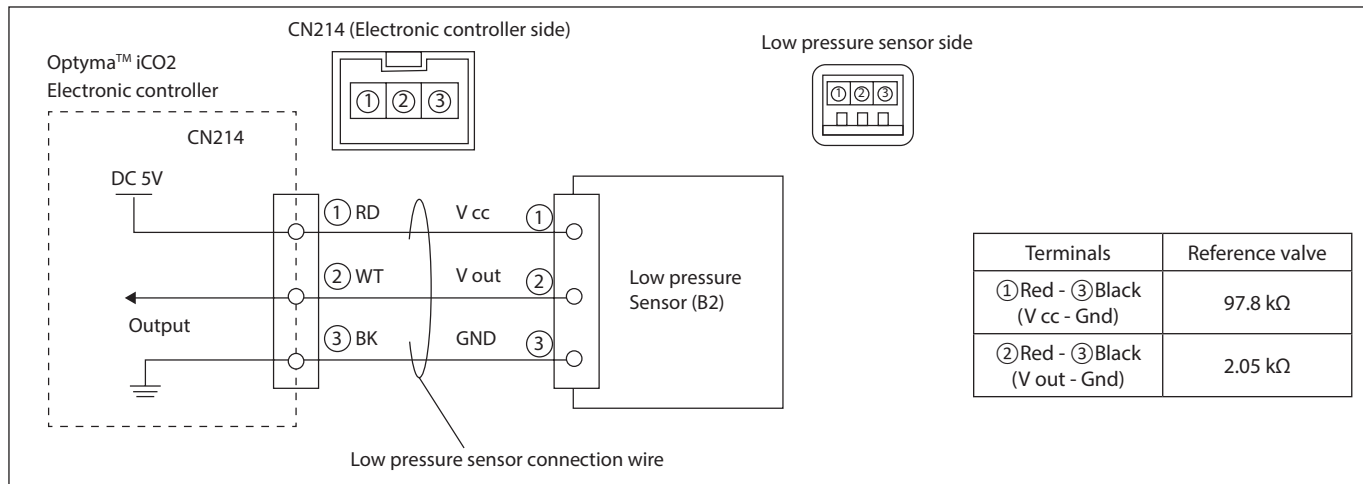

1. Detection condition	Diagnosis flow	Cause (action taken)
<p>1. Wire snapping (approx. 4.5 V to last for 10 s)</p> <p>2. Short circuit (approx. 0.5 V to last for 10 s)</p>	<p>1. To check whether if there is disconnection/abnormal swaging / moisture ingress/wire jamming of the connector by visual check</p> <p>2. To check whether if there is pipes distortion, blockage/ filter blockage</p> <p>3. Conduct diagnosis per following flow chart only when there is no abnormal found by visual check.</p> <pre> graph TD Start[By turning on and off the power supply, cancel error codes and re-start Optyma™ iCO2 unit.] --> D1{Same Error code shows up again?} D1 -- YES --> D1 D1 -- NO --> S1[Turn off mains power (230V AC) to the system (before open maintenance door), then check followings after 5 min. *Corrosion of Optyma™ iCO2 Electronic controller] S1 --> D2{Corrosion found?} D2 -- YES --> C1[Replace failure parts] D2 -- NO --> S2[Disconnect connectors from Optyma™ iCO2 Electronic controller and pressure sensor, and check if there is a wire snapping or/and a short circuit.] S2 --> D3{Wire snapping or short circuit found?} D3 -- YES --> C2[Pressure sensor connecting wire (replace connecting wire)] D3 -- NO --> S3[Measure inter-terminal (①-③, ②-③) resistances for the pressure sensor] S3 --> D4{Wire snapping or short circuit to a part of terminals?} D4 -- YES --> C3[Pressure sensor failure (Replace pressure sensor)] D4 -- NO --> S4[Replace Optyma™ iCO2 Electronic controller, then reset error codes. Restart Optyma™ iCO2 unit.] S4 --> D5{Operates normally?} D5 -- YES --> C4[Optyma™ iCO2 Electronic controller failure (Repair complete)] D5 -- NO --> C5[Refrigerant leak, blockage (Identify leak portion, and replace parts) Watch the consequence] </pre>	
<p>2. Detection timing</p> <p>Power supply ON</p>		
<p>3. Estimated causes</p> <p>Product related factors :</p> <ol style="list-style-type: none"> wiring, connector connecting Optyma™ iCO₂ Electronic controller Low pressure sensor Press. Sensor wiring CO₂ cycle Ref. gas leakage Service valve 		
<p>4. Action when error occurred</p> <p>Optyma™ iCO₂ to suspend its operation.</p>	<p>If the problem cannot be solved by checking only Optyma™ iCO₂, there is a possibility of leakage or blockage in the Evaporator or the piping between a Evaporator and Optyma™ iCO₂, so please check that as well.</p>	

Error code A96 - Discharge temperature error (R1)

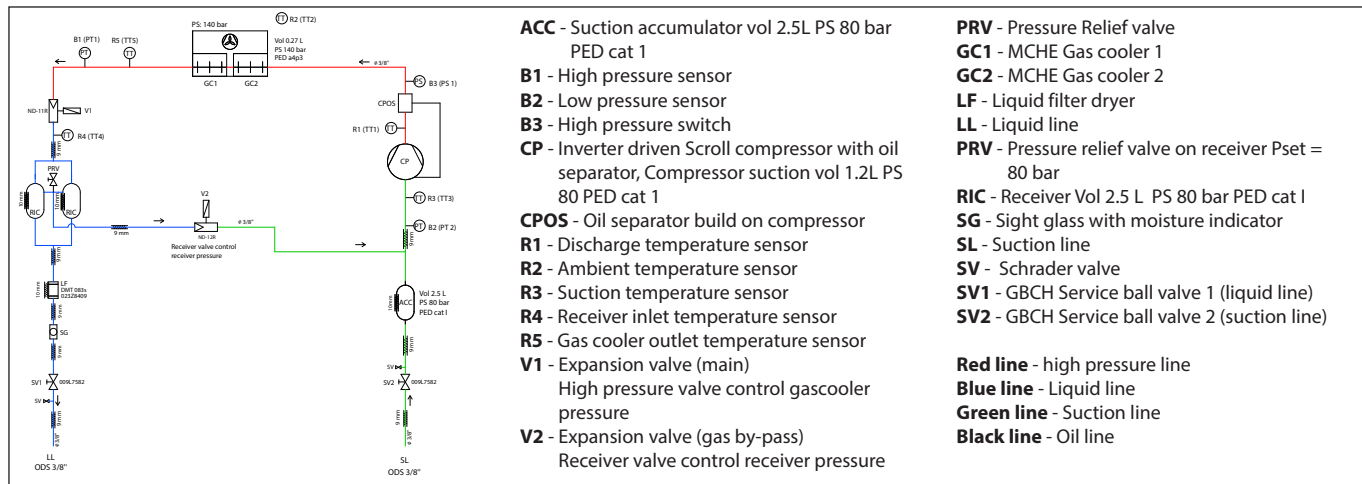

1. Detection condition	Diagnosis flow	Cause (action taken)
Ref. Compressor outlet temp. : Tco to be 138 °C or higher for 5 s or more.	<ol style="list-style-type: none"> To check whether if there is disconnection/abnormal swaging / moisture ingress/wire jamming of the connector/service valves closed / gas cooler blockage (air side) by visual check To check whether if there is pipes distortion, blockage/ filter blockage To check Whether the oil was properly filled at the time of installation If other error code to be shown, follow the diagnosis procedure for that error code. If no any other errors aren't shown, follow process flow shown below: 	
2. Detection timing	<p>Turn off mains power (230V AC) to the system, and turn ON after 5 min. Confirm the noise of "clang-clang" (Zero-reset noise for stepper valve EXV) to come out from Optyma™ iCO2 unit.</p>	
When comp is ON	<p>Decision: "Clang-clang" noise (ex. EXV)?</p> <p>NO → To Check and fix Expansion valve or Bypass valve</p> <p>YES → By turning on and off the power supply, cancel the error code, Power OFF the Optyma™ iCO2 power line, then power ON again after 1 min. Check the operation condition in maintenance mode.</p>	
3. Estimated causes	<p>Decision: Only A96 is shown? No (other error code is shown)</p> <p>YES → Suspend Optyma™ iCO2 operation, measure resistance value of the discharge thermistor parts (see diagnosis flow for error code E32).</p>	Conduct diagnosis based on that error codes (ex. A17, A34)
1. Thermistor is not properly connected.	<p>Decision: 1.0 kΩ or lower?</p> <p>YES → Discharge thermistor failure (replace thermistor set)</p> <p>NO → Check connection if there is a failure for gas cooler outlet / Discharge thermistor</p>	
2. Gas-cooler (air flow failure)	<p>Decision: connection failure of thermistors?</p> <p>YES → Thermistor connection failure (Connect it properly)</p> <p>NO → Able to operate Normally?</p>	Watch the consequence Especially check if super-heat is above 30 °C and Optyma™ iCO2 is stopped by pressure switch
3. Optyma™ iCO2 Electronic controller	<p>Decision: Able to operate Normally?</p> <p>YES → CO2 cycle or Gascooler failure (blockage)</p> <p>NO → If the problem cannot be solved by checking only Optyma™ iCO2, there is a possibility of leakage or blockage in the Evaporator or the piping between a Evaporator and Optyma™ iCO2, so please check that as well.</p>	
4. Expansion valve		
5. Bypass valve		
6. CO2 cycle		
4. Action when error occurred		
Optyma™ iCO2 to suspend its operation if abnormal continues after 10 times of retrial		
Note Retrial control logic: Re-start operation after 3 min. of operation stop.		

Error code E39 - Low pressure sensor (B2) error (suction)

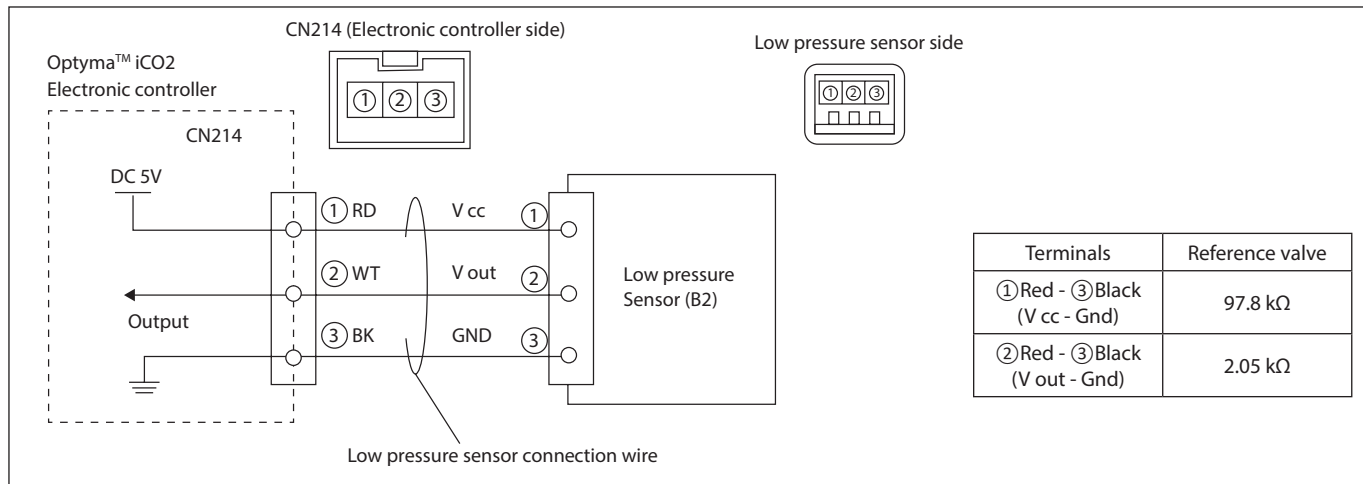

1. Detection condition	Diagnosis flow	Cause (action taken)
1. Wire snapping (approx. 4.5 V to last for 10 s) 2. Short circuit (approx. 0.5 V to last for 10 s)	1. To check whether if there is disconnection/abnormal swaging / moisture ingress/wire jamming of the connector by visual check 2. To check whether if there is pipes distortion, blockage/ filter blockage 3. Conduct diagnosis per following flow chart only when there is no abnormal found by visual check.	
2. Detection timing	By turning on and off the power supply, cancel error codes and re-start Optyma™ iCO2 unit.	
Power supply ON	Same Error code shows up again?	
3. Estimated causes	YES Turn off mains power (230V AC) to the system (before open maintenance door), then check followings after 5 min. *Corrosion of Optyma™ iCO2 Electronic controller	Replace failure parts
Product related factors :	NO Disconnect connectors from Optyma™ iCO2 Electronic controller and pressure sensor, and check if there is a wire snapping or/and a short circuit.	Pressure sensor connecting wire (replace connecting wire)
1. wiring, connector connecting	Wire snapping or short circuit found?	Pressure sensor failure (Replace pressure sensor)
2. Optyma™ iCO2 Electronic controller	Measure inter-terminal (①-③, ②-③) resistances for the pressure sensor	
3. Low pressure sensor	Wire snapping or short circuit to a part of terminals?	
4. Press. Sensor wiring	YES Replace Optyma™ iCO2 Electronic controller, then reset error codes. Restart Optyma™ iCO2 unit.	Optyma™ iCO2 Electronic controller failure (Repair complete)
5. CO2 cycle	NO Operates normally?	Refrigerant leak, blockage (Identify leak portion, and replace parts)
6. Ref. gas leakage	YES Operates normally?	Watch the consequence
7. Service valve	NO If the problem cannot be solved by checking only Optyma™ iCO2, there is a possibility of leakage or blockage in the Evaporator or the piping between a Evaporator and Optyma™ iCO2, so please check that as well.	
4. Action when error occurred		
Optyma™ iCO2 to suspend its operation.		

Error code H23 to H26 - Optyma™ iCO2 Electronic controller error

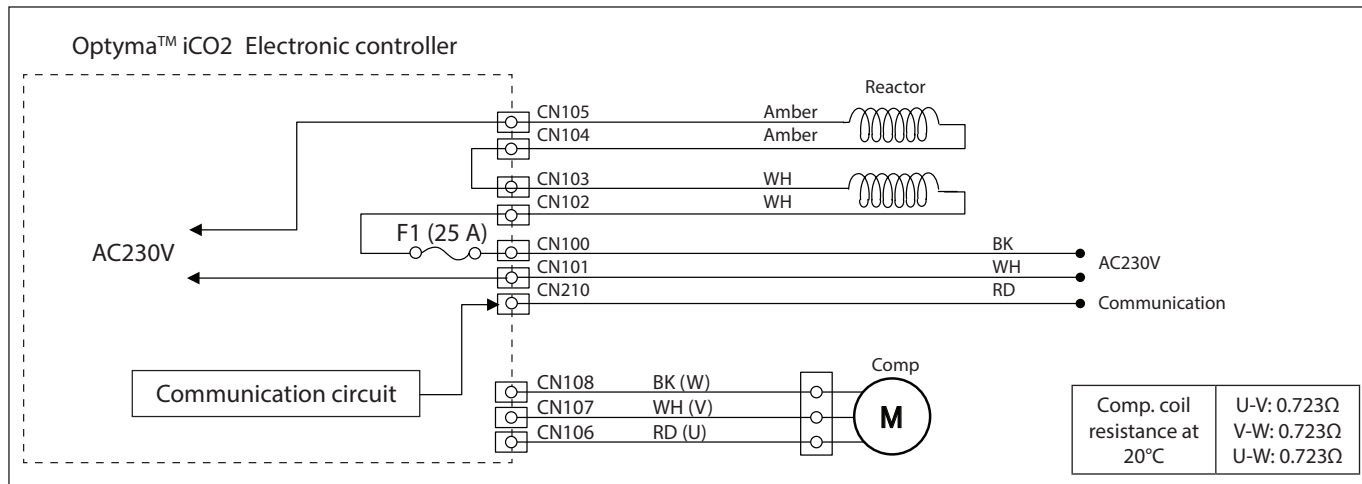

1. Detection condition	Diagnosis flow	Cause (action taken)
Optyma™ iCO2 Electronic controller to receive compressor control failure.	<p>Conduct following checks before starting diagnosis: Whether there is/are Disconnection of connectors, pinch of connector wire at swaging part by visual check.</p> <p>Note This error code won't be shown due to refrigeration cycle abnormal.</p> <div style="border: 1px solid black; padding: 5px; margin: 5px 0;"> Turn off mains power (230V AC) to the system, and turn ON after 5 min. then check following: •Corrosion of Optyma™ iCO2 Electronic controller </div> <p style="text-align: center;">Corrosion?</p> <p style="text-align: center;">NO</p> <div style="border: 1px solid black; padding: 5px; margin: 5px 0;"> Verify poor contact or/and wire snapping for the connectors for both Optyma™ iCO2 Electronic controller side and comp side. </div> <p style="text-align: center;">Abnormal?</p> <p style="text-align: center;">NO</p>	<p>Replace failure parts</p> <p>Properly re-connect failure part, or replace parts</p> <p>Optyma™ iCO2 Electronic controller failure (Replace Optyma™ iCO2 Electronic controller)</p>
<p>2. Detection timing When comp is ON</p> <p>3. Estimated causes 1. Wiring, connector connection 2. Optyma™ iCO2 Electronic controller</p> <p>4. Action when error occurred Optyma™ iCO2 to suspend its operation when error continues after 10 –times of retries. <Retrial control> Return back to normal operation after Optyma™ iCO2 to be suspended for 3 min.</p>		

Error code H28 and H29 - Optyma™ iCO2 Electronic controller error

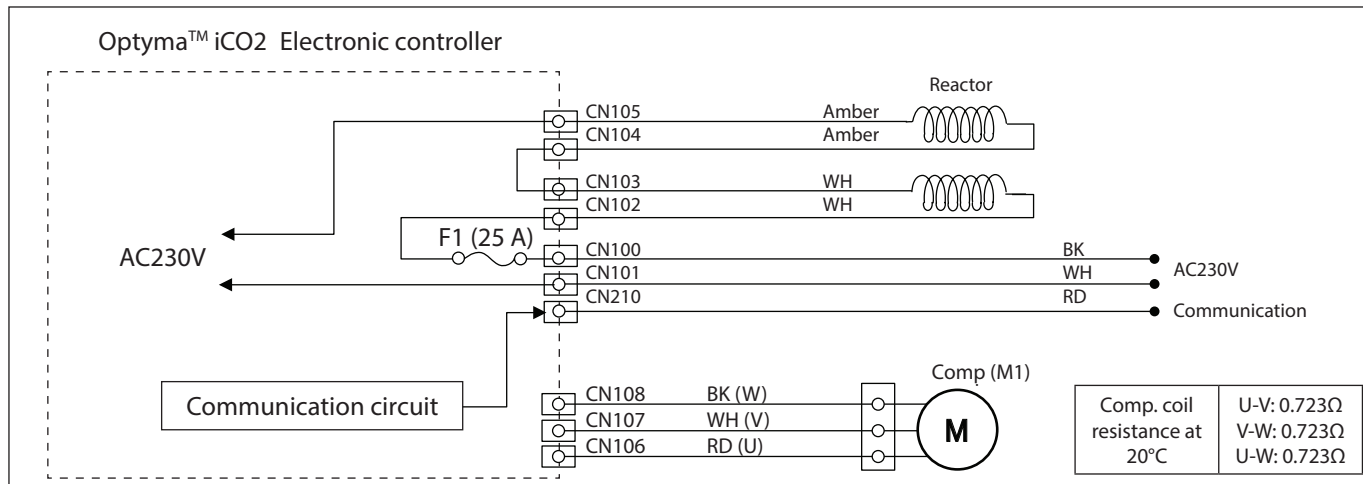

1. Detection condition	Diagnosis flow	Cause (action taken)
Optyma™ iCO2 Electronic controller to receive compressor control abnormal (H28, H29)	<ol style="list-style-type: none"> To check whether if there is disconnection/abnormal swaging / moisture ingress/wire jamming of the connector/service valves closed / gas cooler blockage (air side) by visual check To check whether if there is pipes distortion, blockage/ filter blockage To check Whether the oil was properly filled at the time of installation If other error code to be shown, follow the diagnosis procedure for that error code. If no any other errors aren't shown, follow process flow shown below: 	
2. Detection timing	<p>Turn off mains power (230V AC) to the system, and turn ON after 5 min. Confirm the noise of "clang-clang" (Zero-reset noise for stepper valve EXV) to come out from Optyma™ iCO2 unit.</p>	
When Comp is ON (H28, H29)	<p>Decision: "Clang-clang" noise (ex. EXV)?</p> <p>NO → To Check and fix Expansion valve or Bypass valve</p> <p>YES → Turn off mains power (230V AC) to the system, then confirm following points after 5 minutes</p> <ul style="list-style-type: none"> • Corrosion of Optyma™ iCO2 Electronic controller <p>Decision: Corrosion?</p> <p>YES → Replace abnormal parts</p> <p>NO → Verify poor contact or/and wire snapping for the connectors for both Optyma™ iCO2 Electronic controller side and comp side.</p> <p>Decision: Abnormal?</p> <p>YES → (Re-connect failure portion, or replace failure parts)</p> <p>NO → Confirm connection of gas cooler outlet thermistor, Compressor outlet Thermistor</p> <p>Decision: connection failure of thermistors?</p> <p>YES → Thermistor connection failure (Properly re-connect the parts)</p> <p>NO → Replace Optyma™ iCO2 Electronic controller, then re-start Optyma™ iCO2</p> <p>Decision: Able to operate Normally?</p> <p>YES → Optyma™ iCO2 Electronic controller failure (Repair complete)</p> <p>NO → Comp or CO2 cycle failure (Replace Optyma™ iCO2 unit)</p>	
3. Estimated causes		
Product related factors :		
1. Power fluctuates seriously (Fluctuates more than 5 V momentary)		
Product related factors :		
1. wiring, connector connection		
2. Optyma™ iCO2 Electronic controller		
3. Comp		
4. Action when error occurred		
Optyma™ iCO2 to suspend its operation when error continues after 10 –times of retrials.		
<Retrial control> Return back to normal operation after Optyma™ iCO2 to be suspended for 3 min.		
	<p>If the problem cannot be solved by checking only Optyma™ iCO2, there is a possibility of leakage or blockage in the Evaporator or the piping between a Evaporator and Optyma™ iCO2, so please check that as well.</p>	

Error code E42 - Discharge pressure sensor (B1) error

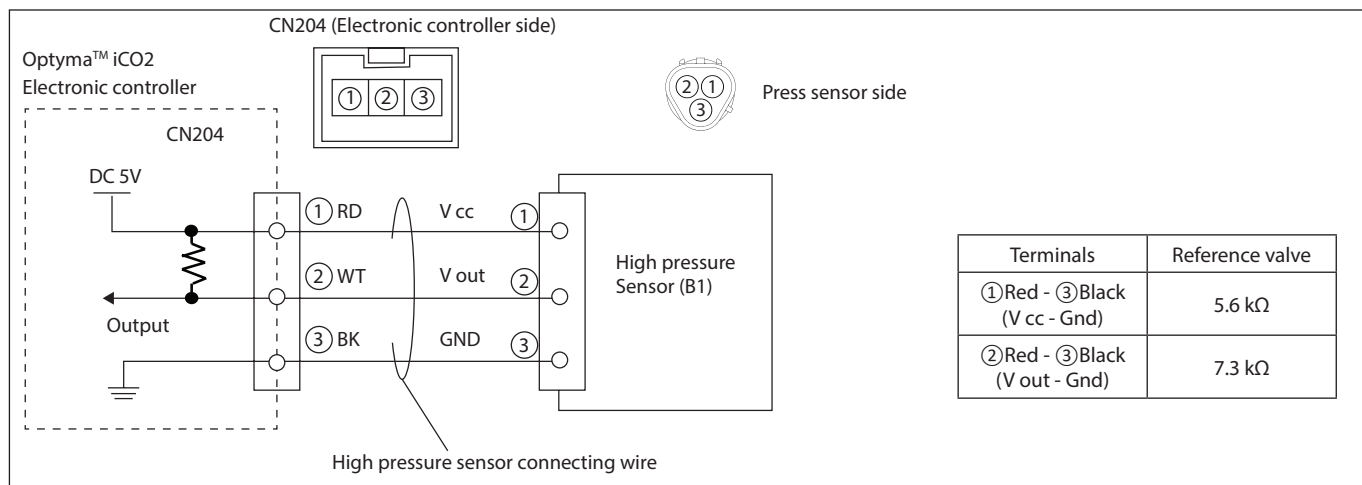

1. Detection condition	Diagnosis flow	Cause (action taken)
<p>1. Wire snapping (approx. 5 V to last for 10 s)</p> <p>2. Short circuit (approx. 0.5 V to last for 10 s)</p>	<p>1. To check whether if there is disconnection/abnormal swaging / moisture ingression/wire jamming of the connector/service valves closed / gas cooler blockage (air side) by visual check</p> <p>2. To check whether if there is pipes distortion, blockage/ filter blockage</p> <p>3. To check Whether the oil was properly filled at the time of installation</p> <p>4. If other error code to be shown, follow the diagnosis procedure for that error code.</p> <p>5. If no any other errors aren't shown, follow process flow shown below:</p> <div style="border: 1px solid black; padding: 5px; margin: 5px 0;"> <p>Referring to a log data, Pressure sensor failure to be established if E41 and A17 are to be shown at the same time.</p> </div> <div style="border: 1px solid black; padding: 5px; margin: 5px 0;"> <p>Cancel error codes and re-start Optyma™ iCO2 unit. For reset all the alarms, switch off CDU unit, wait five minutes and switch on the unit.</p> </div> <p>Same Error code shows up again?</p> <p>YES</p> <p>NO</p> <div style="border: 1px solid black; padding: 5px; margin: 5px 0;"> <p>Turn off mains power (230V AC) to the system (before open maintenance door), then check followings after 5 min. •Corrosion of Optyma™ iCO2 Electronic controller</p> </div> <p>Corrosion found?</p> <p>YES</p> <p>NO</p> <div style="border: 1px solid black; padding: 5px; margin: 5px 0;"> <p>Disconnect connectors from Optyma™ iCO2 Electronic controller and pressure sensor, and check if there is a wire snapping or/and a short circuit.</p> </div> <p>Wire snapping or short circuit found?</p> <p>YES</p> <p>NO</p> <div style="border: 1px solid black; padding: 5px; margin: 5px 0;"> <p>Measure inter-terminal (①-③, ②-③) resistances for the pressure sensor</p> </div> <p>Wire snapping or short circuit to a part of terminals?</p> <p>YES</p> <p>NO</p> <div style="border: 1px solid black; padding: 5px; margin: 5px 0;"> <p>Replace Optyma™ iCO2 Electronic controller, then reset error codes. Restart Optyma™ iCO2 unit.</p> </div> <p>Operates normally?</p> <p>YES</p> <p>NO</p>	<p>Replace failure parts</p> <p>Pressure sensor connecting wire (replace connecting wire)</p> <p>Pressure sensor failure (Replace pressure sensor)</p> <p>Optyma™ iCO2 Electronic controller failure (Repair complete)</p> <p>Refrigerant leak, blockage (Identify leak portion, and replace parts)</p> <p>Watch the consequence</p>
2. Detection timing		
Power supply ON		
3. Estimated causes		
<p>Product related factors:</p> <ol style="list-style-type: none"> wiring, connector connecting Optyma™ iCO2 Electronic controller High pressure sensor Press. Sensor wiring Refrigeration cycle Ref. gas leakage Gas cooler 		
4. Action when error occurred		
Optyma™ iCO2 to suspend its operation	<p>If the problem cannot be solved by checking only Optyma™ iCO2, there is a possibility of leakage or blockage in the Evaporator or the piping between a Evaporator and Optyma™ iCO2, so please check that as well.</p>	

Error code A85 - Medium temperature/pressure alarm

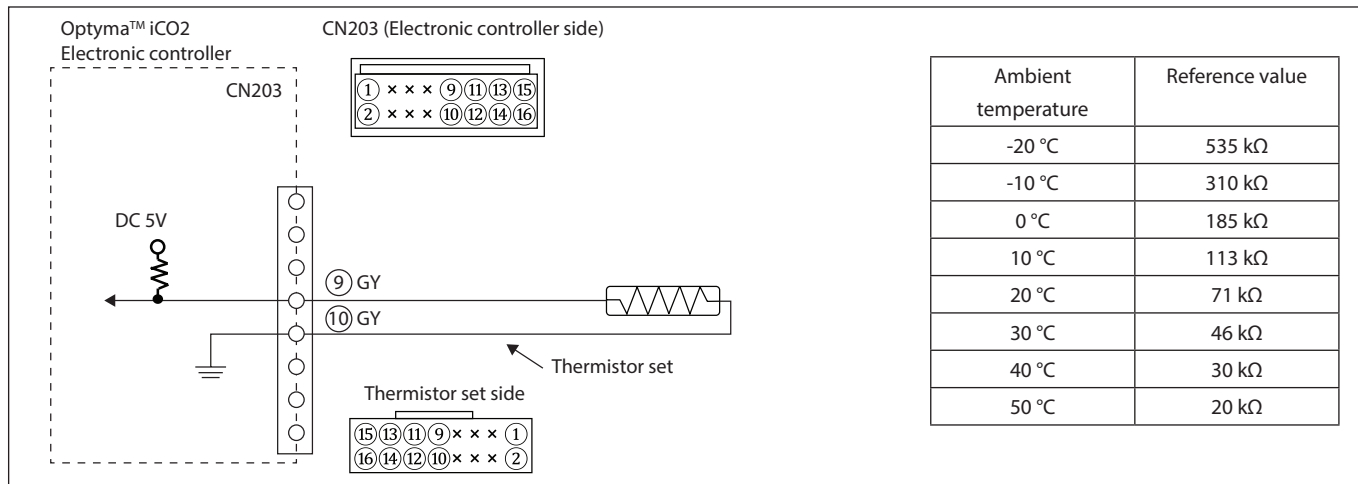

1. Detection condition	Diagnosis flow	Cause (action taken)
<p>Receiver thermistor value is 33 °C or higher for 5 s or more.</p>	<p>1. To check whether if there is disconnection/abnormal swaging / moisture ingress/wire jamming of the connector/service valves closed / gas cooler blockage (air side) by visual check</p> <p>2. To check whether if there is pipes distortion, blockage/ filter blockage</p> <p>3. To check whether if there is anything around the Optyma™ iCO2 that raises the intake air temperature of the Optyma™ iCO2 (heating element, wall surrounding the Optyma™ iCO2, etc.)</p> <p>4. If other error code to be shown, follow the diagnosis procedure for that error code.</p> <p>5. If no any other errors aren't shown, follow process flow shown below:</p> <div style="border: 1px solid black; padding: 5px; margin: 5px 0;"> <p>Turn off mains power (230V AC) to the system, and turn ON after 5 min. Confirm the noise of "clang-clang"(Zero-reset noise for stepper valve) to come out from Optyma™ iCO2 unit.</p> </div> <p style="text-align: center;">NO</p> <p style="text-align: center;">"Clang-clang" noise (ex. EXV)?</p> <p style="text-align: center;">YES</p> <div style="border: 1px solid black; padding: 5px; margin: 5px 0;"> <p>Cancel the error code, Power OFF the Optyma™ iCO2 power line, then power ON again after 1 min. Check the operation condition in maintenance mode.</p> </div> <p style="text-align: center;">No (other error code is shown)</p> <p style="text-align: center;">Only Sr3 is shown?</p> <p style="text-align: center;">YES</p> <div style="border: 1px solid black; padding: 5px; margin: 5px 0;"> <p>Suspend Optyma™ iCO2 operation, measure resistance value of the receiver thermistor parts(see diagnosis flow for E32).</p> </div> <p style="text-align: center;">YES</p> <p style="text-align: center;">Abnormal?</p> <p style="text-align: center;">NO</p> <div style="border: 1px solid black; padding: 5px; margin: 5px 0;"> <p>Check connection if there is a failure for: Receiver thermistor</p> </div> <p style="text-align: center;">YES</p> <p style="text-align: center;">connection failure of thermistors?</p> <p style="text-align: center;">NO</p> <div style="border: 1px solid black; padding: 5px; margin: 5px 0;"> <p>Replace Optyma™ iCO2 Electronic controller, then re-start Optyma™ iCO2</p> </div> <p style="text-align: center;">YES</p> <p style="text-align: center;">Able to operate Normally?</p> <p style="text-align: center;">NO</p>	<div style="border: 1px solid black; padding: 5px; margin: 5px 0; text-align: center;"> <p>To Check and fix Expansion valve or Bypass valve</p> </div> <p style="margin-top: 20px;">Conduct diagnosis based on that error codes (ex. A17, E31, A96 or Sr3, A34 or Sr2)</p> <p style="margin-top: 20px;">Receiver Thermistor failure (Replace thermistor set)</p> <p style="margin-top: 20px;">Thermistor connection failure (Connect it properly)</p> <p style="margin-top: 20px;">Watch the consequence</p> <p style="margin-top: 20px;">CO2 cycle or Gas cooler failure (Replace parts)</p>
<p>2. Detection timing</p> <p>When Comp is ON</p>		
<p>3. Estimated causes</p> <p>Product related factors:</p> <ol style="list-style-type: none"> 1. wiring, connector connecting 2. Optyma™ iCO2 Electronic controller 3. Refrigeration cycle 4. Expansion valve 5. Bypass valve 6. Fan 		
<p>4. Action when error occurred</p> <p>Optyma™ iCO2 to suspend its operation when error continues after 10 –times of retrials.</p> <p><Retrial control> Return back to normal operation after Optyma™ iCO2 to be suspended for 3 min.</p>	<p>If the problem cannot be solved by checking only Optyma™ iCO2, there is a possibility of leakage or blockage in the Evaporator or the piping between a Evaporator and Optyma™ iCO2, so please check that as well.</p>	

Error code A97 - High pressure sensor safety switch (B3) alarm

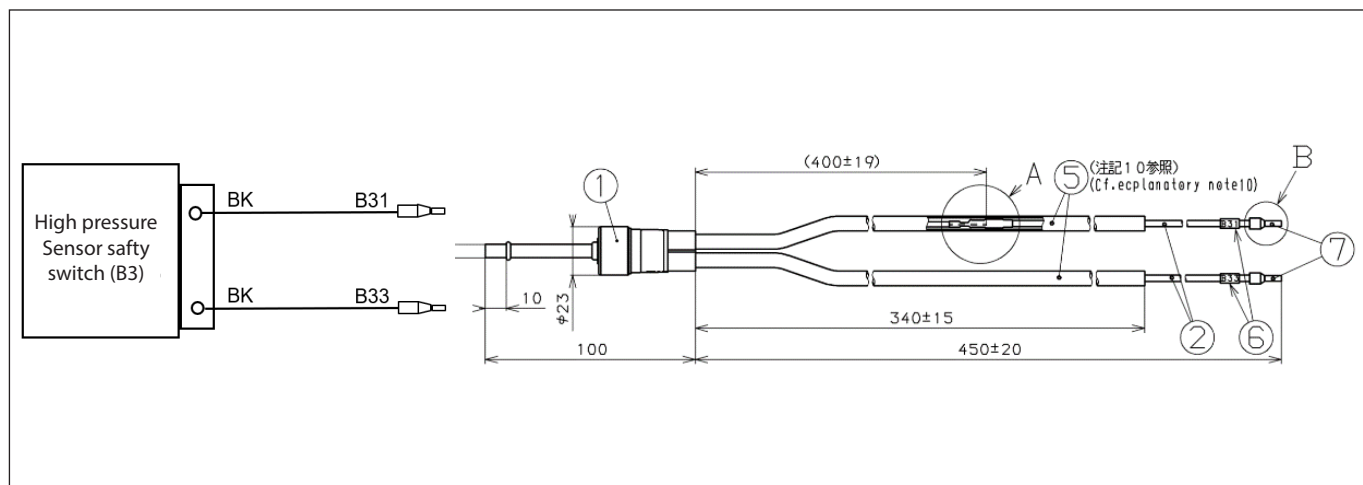

1. Detection condition	Diagnosis flow	Cause (action taken)
High pressure sensor safety switch (B3) alarm. CDU cannot run (fan and compressor switched off)	1. To check whether if there is disconnection/abnormal swaging / moisture ingression/wire jamming of the connector/service valves closed / gas cooler blockage (air side) by visual check 2. To check whether if there is pipes distortion, blockage/ filter blockage 3. Conduct diagnosis per following flow chart only when there is no abnormal found by visual check.	
	Measure continuity of the high pressure sensor safety switch (B3), between B31 and B33	
	Continuity	High pressure sensor safety switch (B3) or wire failure (Replace failure parts)
	YES	
2. Detection timing	Check that continuity is present between pin B34 and B12	
Start signal from GW and cooling cap demand are present but CDU is not running	Continuity?	Check wire connection or replace thermal switch
	YES	
3. Estimated causes	Check corrosion of the Optyma iCO2 controller	
1. Pressure in the circuit higher than 140 bar 2. Pressure switch broken 3. Protection circuit broken 4. Optyma™ iCO2 Electronic controller	Corrosion	Replace controller
	YES	
	NO	
4. Action when error occurred	Check Gateway	Watch the consequence
Optyma™ iCO2 to suspend its operation if abnormal continues after 10 times of retrial	YES	
	NO	Optyma™ iCO2 failure (blockage) Gateway failure
Note Retrial control logic: Re-start operation after 3 min. of operation stop.	If the problem cannot be solved by checking only Optyma™ iCO2, there is a possibility of leakage or blockage in the Evaporator or the piping between a Evaporator and Optyma™ iCO2, so please check that as well.	

Error code A45 - Main Switch OFF

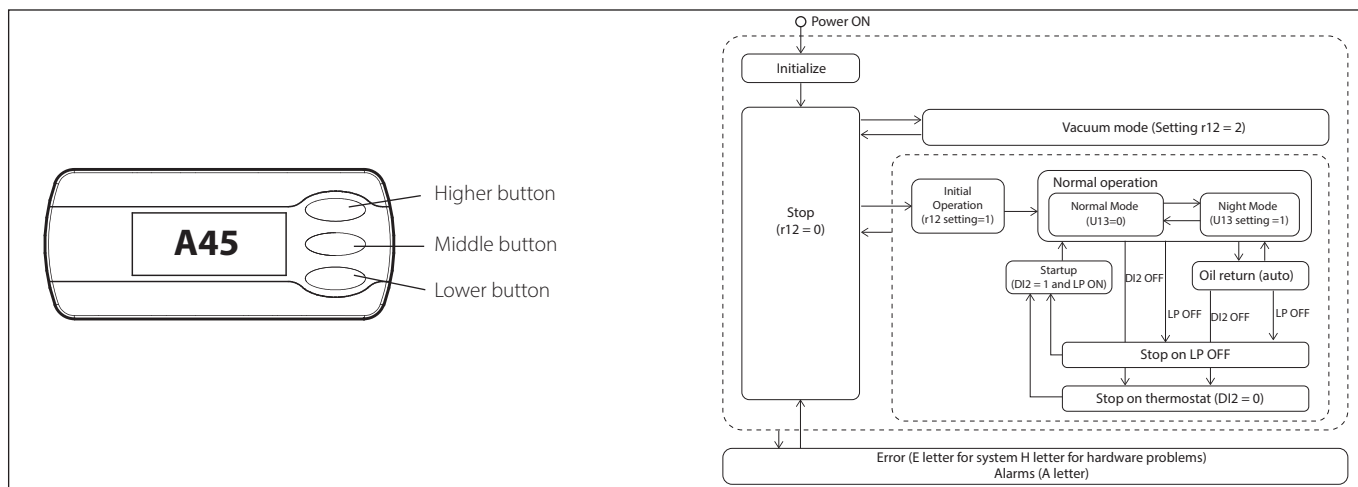

1. Detection condition	Diagnosis flow	Cause (action taken)
Display show alarm A45	<p>1. Controller main switch off mean that the internal controller is on Stop Mode meaning R12 parameter =0</p> <div style="border: 1px solid black; padding: 5px; margin-bottom: 5px; text-align: center;">Go to Menu on the MMILDS Display (pushing higher button for 5 second)</div> <div style="border: 1px solid black; padding: 5px; margin-bottom: 5px; text-align: center;">Navigate to R12 parameter</div> <div style="border: 1px solid black; padding: 5px; margin-bottom: 5px; text-align: center;">Push middle button to Select R12 parameter</div> <div style="border: 1px solid black; padding: 5px; margin-bottom: 5px; text-align: center;">Change the setting to 1 for operation or to start cooling</div> <div style="text-align: center;"> <p>Compressor start</p> <p>YES</p> <p>NO</p> </div>	<p>Check Error or Alarm code on the MMILDS display</p>
2. Detection timing		
3. Estimated causes		
4. Action when error occurred		
Start from powering the unit or after maintenance or Charging procedure		
Wrong setting of the parameter		
1. Initialization		
2. Vacuum mode		
3. From wrong parameter/mode setting		

Error code: 10 – times of retrials

Retry operation

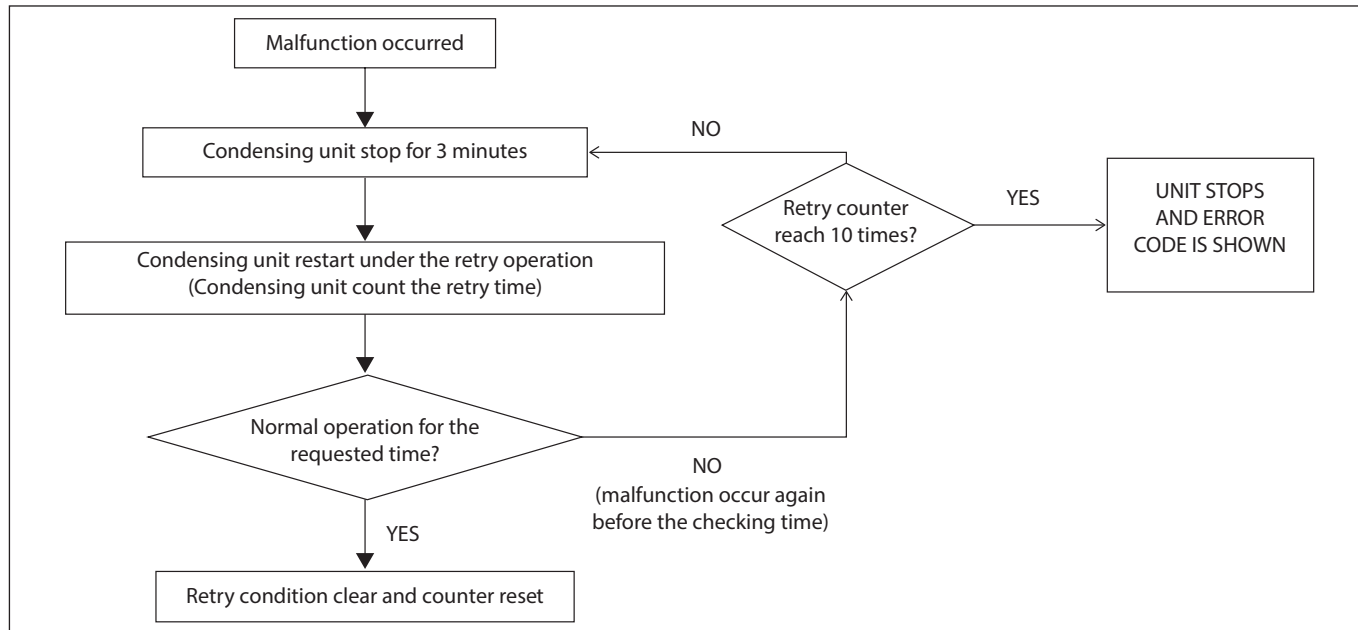

Updates

Release date (Year/Month)	Guideline codification number	List of changes	Reason for change
2022/06	AB399636244436en-000101	First release	-
2023/01	AB399636244436en-000301	Pump down standard operation mode, +46 operation	Gateway (1.10) and Software (V2) update



Danfoss Cooling

is a worldwide manufacturer of compressors and condensing units for refrigeration and HVAC applications. With a wide range of high quality and innovative products we help your company to find the best possible energy efficient solution that respects the environment and reduces total life cycle costs.

We have 40 years of experience within the development of hermetic compressors which has brought us amongst the global leaders in our business, and positioned us as distinct variable speed technology specialists. Today we operate from engineering and manufacturing facilities spanning across three continents.



Our products can be found in a variety of applications such as rooftops, chillers, residential air conditioners, heatpumps, coldrooms, supermarkets, milk tank cooling and industrial cooling processes.

member of:



Danfoss A/S
Climate Solutions • danfoss.com • +45 7488 2222

Any information, including, but not limited to information on selection of product, its application or use, product design, weight, dimensions, capacity or any other technical data in product manuals, catalogues descriptions, advertisements, etc. and whether made available in writing, orally, electronically, online or via download, shall be considered informative, and is only binding if and to the extent, explicit reference is made in a quotation or order confirmation. Danfoss cannot accept any responsibility for possible errors in catalogues, brochures, videos and other material. Danfoss reserves the right to alter its products without notice. This also applies to products ordered but not delivered provided that such alterations can be made without changes to form, fit or function of the product. All trademarks in this material are property of Danfoss A/S or Danfoss group companies. Danfoss and the Danfoss logo are trademarks of Danfoss A/S. All rights reserved.