



Gear actuators

AME 25 / AME 35

Description

AME electric actuators are used with, VRB, VRG, VF, VL valves with additional adapter (Code No. 065Z0311, not supplied) and VFS 2 valves up to DN 50 diameter.

The actuator automatically adapts its stroke to valve end positions which reduces commissioning time.

Features & benefits

- The advanced design incorporates load related 'switch-off' to ensure that actuators and valves are not exposed to overload
- The advanced design incorporates a diagnostic LED, operational data capture and self stroking feature
- Low weight and robust

Ordering

Product code numbers

Actuators

Type	Supply voltage (Vac)	Code No.	Only for Danish market VVS-nr.
AME 25	24	082G3025	46 0946.025
AME 35		082G3022	46 0946.035

Accessories code numbers

Type	Code No.	Only for Danish market VVS-nr.
Adapter for VFS 2 valve DN 15-50 (for media temp. over 150 °C)	065Z7548	46 0946.908
Adapter for VRB/VRG/VF/VL valves (gen.2009) DN 15-50	065Z0311*	46 0946.912
Stem heater for VFS valve DN 15-50	065B2171	46 0946.801
Clutch AMV(E) 25, AMV(E) 35	003G6396	-

* Needs to be ordered separately.

Overview

Product portfolio

Actuator - valve combinations

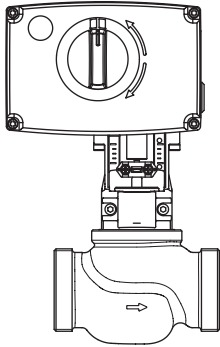

AME 25, AME 35 +
Adapter (065Z0311)
VRB 2, VRB 3 ext. thread (DN 15-50)
VRG 2, VRG 3 ext. thread (DN 15-50)

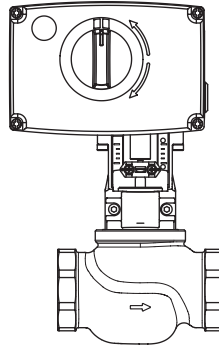

AME 25, AME 35 +
Adapter (065Z0311)
VRB 2, VRB 3 int. thread
(DN 15-50)

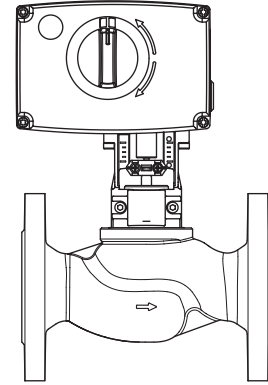

AME 25, AME 35 +
Adapter (065Z0311)
VF 2, VF 3 (DN 15-50)
VL 2, VL 3 (DN 15-50)

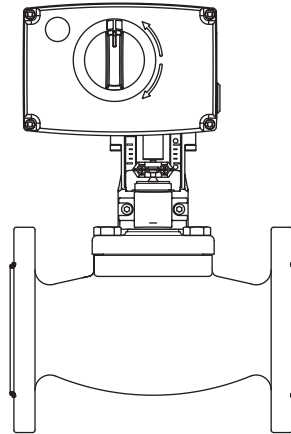

AME 25, AME 35 +
VFS 2 (DN 15-50)

Functions

Operation

Commissioning

Complete the mechanical and electrical installation and perform the necessary checks and tests:

- Isolate control medium. (E.g. self stroking in a steam application without suitable mechanical isolation could cause a hazard).
- Apply the power (*Note that the actuator will now perform the self stroking function*)
- Apply the appropriate control signal and check the valve stem direction is correct for the application.
- Ensure that the actuator drives the valve over its full stroke, by applying the appropriate control signal. This action will set the valve stroke length.

The unit is now fully commissioned.

Commissioning / testing feature

The actuator can be driven to the fully open or closed positions (depending on valve type) by connecting SN to terminals 1 or 3.

Manual override

The manual override is achieved by turning the manual knob to the required position.

Observe the direction of rotation symbol.

If manual override has been used then X and Y signal are not correct until the actuator reaches its end position. If this is not accepted, mount accessory active return signal kit.

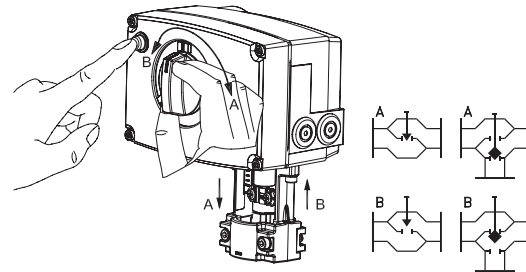

Procedure

- Press rubber button
- Adjust valve position using control knob
- Set valve to closed position
- Restore power supply

Settings

DIP switch setting

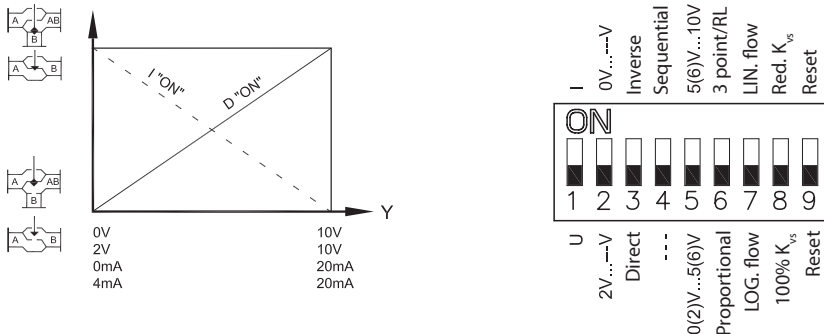

The actuator has a function selection DIP switch under the removable cover. In particular, if SW6 is set to ON, the actuator will perform as 3-point actuator. The switch provides the following functions:

SW1: U/I - Input signal type selector:

If set to OFF position, voltage input is selected. If set to ON position, current input is selected.

SW2: 0/2 - Input signal range selector:

If set to OFF position, the input signal is in the range from 2-10 V (voltage input) or from 4-20 mA (current input). If set to ON position, the input signal is in the range from 0-10 V (voltage input) or from 0-20 mA (current input).

SW3: D/I - Direct or inverse acting selector:

If set to OFF position, the actuator is direct acting (stem lowers as voltage increases). If actuator is set to ON position the actuator is inverse acting (stem raises as voltage increases).

SW4: —/Seq - Normal or sequential mode selector:

If set to OFF position, the actuator is working in range 0(2)-10 V or 0(4)-20 mA. If set to ON position, the actuator is working in sequential range; 0(2)-5(6) V or (0(4)-10(12) mA) or (5(6)-10 V) or (10(12)-20 mA).

SW5: 0-5 V/5-10 V - Input signal range in sequential mode:

If set to OFF position, the actuator is working in sequential range 0(2)-5(6) V or 0(4)-10(12) mA.

If set to ON position, the actuator is working in sequential range; 5(6)-10 V or 10(12)-20 mA.

SW6: Prop./3-pnt - Modulating or 3-point mode selector:

If set to OFF position, the actuator is working normally according to control signal. If set to ON position, the actuator is working as 3-point actuator.

For this operation please refer to Installation section (wiring 3-point control).

When DIP switch SW6 is set to ON than all functions from other DIP switch become inactive.

SW7: LOG/LIN - Equal percentage or linear flow through valve selector¹⁾:

If set to OFF position, the flow through valve is equal percentage. If set to ON position, the flow through valve is linear according to control signal.

SW8: 100% K_{vs}/Reduced K_{vs} - Flow reduction through valve selector¹⁾:

If set to OFF position, the flow through valve is not reduced. If set to ON position, the flow through valve is reduced by half of increment between standard K_{vs} values. Example: valve with K_{vs} 16 and SW8 set to ON – maximum flow through the valve is K_{vs} 13 (middle between standard K_{vs} 16 and next lower standard K_{vs} 10).

¹⁾ **NOTE:** To be used only in combination with valves with equal percentage characteristic.

SW9: Reset:

Changing this switch position will cause the actuator to go through a self stroking cycle.

Product details

General data

Type		AME 25	AME 35
Power supply	V	24 ac; +10 to -15%	
Power consumption	VA	4	9
Frequency	Hz	50/60	
Control input Y	V	0-10 (2-10) Ri = 24 k Ω	
	mA	0-20 (4-20) Ri = 500 Ω	
Output signal X	V	0-10 (2-10)	
Closing force	N	1000	600
Max. stroke	mm	15	
Speed by 50(60) Hz	s/mm	11 (8.8)	3 (2.4)
Max. medium temperature	°C	150 (200 - with adapter or mounted horizontally)	
Ambient temperature		0 ... 55	
Storage and transport temp.		-40 ... 70	
Grade of enclosure		IP 54	
Weight	kg	1.70	

Dimensions

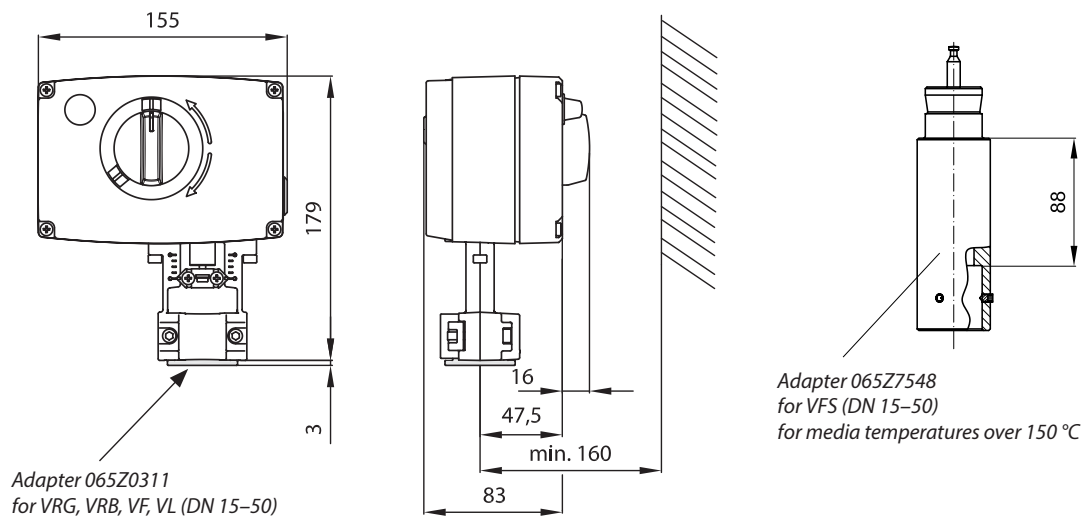

Installation

$T_{\max} \leq 150^{\circ}\text{C}$ for AME 25, 35
and VRB, VRG, VF and VL

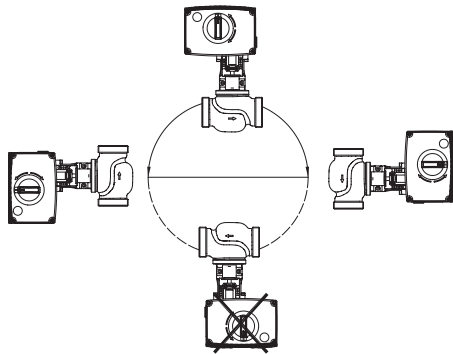

$T_{\max} \leq 150^{\circ}\text{C}$ for AME 25, 35
and VFS

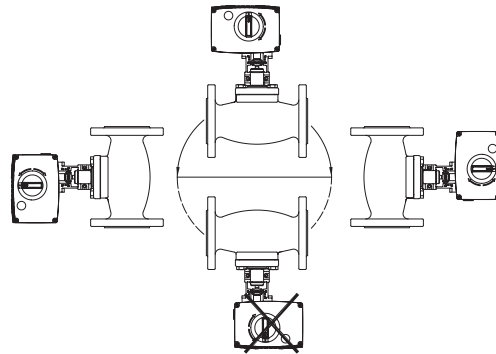

$T_{\max} = 200^{\circ}\text{C}$ for AME 25, 35
and VFS

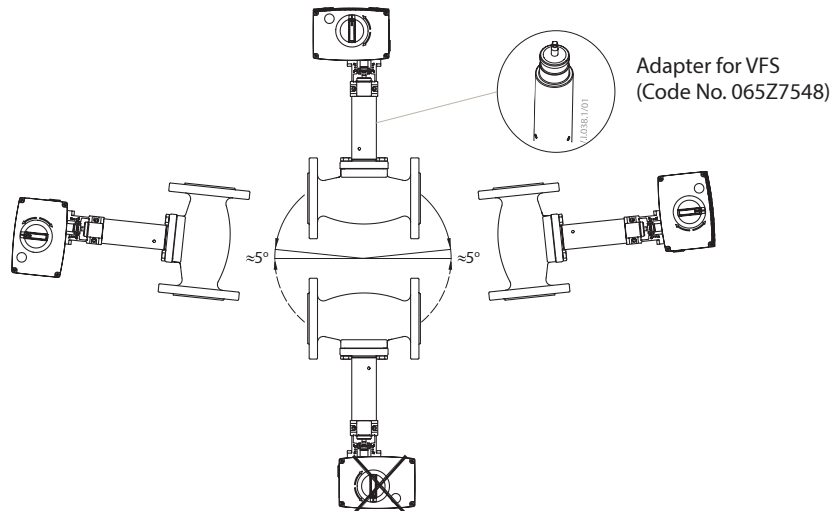

Mechanical

Use 4 mm Allan key (not part of actuator delivery) to mount actuator on the valve. Installation of the valve with the actuator is allowed in horizontal position or upwards. Installation downwards is not allowed.

The actuator must not be installed in an explosive atmosphere, at ambient temperature lower than 0°C or at ambient temperature higher than 55°C . It must not be subject to steam jets, water jets or dripping liquid as well.

Note: the actuator may be rotated up to 360° with respect to the valve stem by loosening the retaining fixture. Once the actuator is placed, retighten the fixture.

Electrical

Electrical connections can be accessed by removing the actuator cover. Two cable gland entries with thread (M20 x 1.5 and M16 x 1.5) are prepared for cable glands.

Note: Cable and cable gland used must not compromise the actuator's IP rating, and must ensure the connectors are fully strain relieved. Please observe local rules and regulations as well.

Wiring

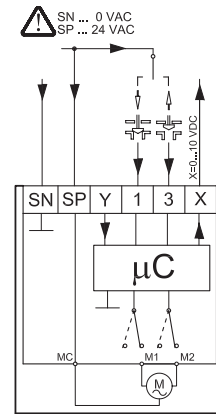
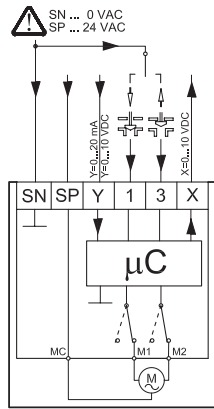

Note: If switch SW6 is set to ON than use this wiring.

Wiring for modulating control

Automatic self stroking feature

When power is first applied, the actuator will automatically adjust to the length of the valve stroke. Subsequently, the self stroking feature can be re-initialised by changing position of SW9.

Diagnostic LED

The red diagnostic LED is located on the pcb under the cover. It provides indication of three operational states:

- Actuator Healthy (Permanently ON),
- Self Stroking (Flashes once per second),
- Error (Flashes 3 times per second - seek technical assistance).

Wiring for 3-point control

Wiring length	Recommended square of the wiring
0-50 m	0.75 mm ²
> 50 m	1.5 mm ²

SP	24 V ac	Power supply
SN	0 V	Common
Y	0-10 V	Input signal
	(2-10 V)	
	0-20 mA (4-20 mA)	
X	0-10 V	Output signal
	(2-10 V)	

Certificates, declarations and approvals

The list contains all certificates, declarations, and approvals for this product type. Individual code number may have some or all of these approvals, and certain local approvals may not appear on the list.

When you click on the link you will be directed to the latest version of the 'Declaration of Conformity'. Products developed and sold before this date of issue conform to the directives/standards in force at the time of their sale.

Approval type	Title	Certification body	Approval topic
Export Control Declaration	Gear and Thermal actuators	Danfoss	
UA Declaration	UA Actuators 2024-06-27	Danfoss	EMC, LVD
EU Declaration	Danfoss EU 221011EN0815101.04	Danfoss	LVD, EU RoHS

Contact details

Online support

Danfoss offers a wide range of support along with our products, including digital information, software, mobile apps and expert guidance. See the possibilities below.



The Danfoss Design center

Discover the Design Center, our advanced digital platform that streamlines product selection. With integrated tools and enhanced type pages, it's simpler than ever to access product information and documentation, and to select the right products. Check the availability of Danfoss products at partner locations and enjoy seamless transitions from selection to purchase with our basket-to-basket functionality. Whether you're buying from our distributors or directly from the Product Store, the Design Center simplifies your experience. Learn more at: designcenter.danfoss.com.



The Danfoss product store

The Danfoss Product Store is a one-stop shop available 24/7 for our customers, no matter where you are in the world or what area of industry you work in. Browse our catalog, check product details and documentation, view your prices and product availability, and quickly finalize your purchase. Start browsing at: store.danfoss.com.



Danfoss Partner Portal/Product Data tool

Designed to support you with easy access to product data extracts, essential resources, tools, and information. The Partner Portal provides a centralized hub for product documentation, training materials, marketing assets, and technical support, ensuring you have everything you need to succeed and grow your business with Danfoss. The Partner Portal is available 24/7 at: partner.danfoss.com and is ready to support your business.



Find technical documentation

Find technical documentation you need to get your project up running. Get direct access to our official collection of data sheets, certificates and declarations, manuals and guides, 3D models and drawings, case stories, brochures, and much more. Start searching now at: documentation.danfoss.com.



Danfoss Learning

Danfoss Learning is a free online learning platform. It features courses and materials specifically designed to help engineers, installers, service technicians, and wholesalers better understand the products, applications industry topics, and trends that will help you do your job better. Find your local Danfoss website here: learning.danfoss.com.



Get local information and support

Local Danfoss websites are the main sources for help and information about our company and products. Find product availability, get the latest regional news, or connect with a nearby expert - all in your own language. Find your local Danfoss website here: danfoss.com.

Danfoss A/S

Climate Solutions . danfoss.com . +45 7488 2222

Any information, including, but not limited to information on selection of product, its application or use, product design, weight, dimensions, capacity or any other technical data in product manuals, catalogues description, advertisements, etc. and whether made available in writing, orally, electronically, online or via download, shall be considered informative, and is only binding if and to the extent, explicit reference is made in a quotation or order confirmation. Danfoss cannot accept any responsibility for possible errors in catalogues, brochures, videos and other material. Danfoss reserves the right to alter its products without notice. This also applies to products ordered but not delivered provided that such alterations can be made without changes to form, fit or function of the products. All trademarks in this material are property of Danfoss A/S or Danfoss group companies. Danfoss and the Danfoss logo are trademarks of Danfoss A/S. All rights reserved.
