

Application guidelines

Danfoss scrolls, **H-Series** Residential and light commercial

R22, R407C, R410A; 50 - 60 Hz



GENERAL INFORMATION	4	Manage superheat.....	32
		Requirement	32
		System evaluation	32
		Test, criteria and solutions.....	33
PRODUCT INFORMATION.....	5	Manage off cycle migration	34
Features.....	5	Requirement	34
Compressor model designation	6	Evaluate the risk.....	34
Nomenclature.....	6	Test, criteria and solutions.....	35
Technical specifications	7	On/off cycling (cycle rate limit)	35
50-60 Hz data.....	7	Provide power supply and electrical	
Dimensions	10	protection	36
HRM025-032-034-038-040-042 / HRP025-034-038-		Wiring information.....	36
040-042 / HRH029-031-032-034-036-038 / HRM-045-		Control logic.....	37
047 / HRP-045-047 / HRH039-040.....	10	Safety control logic requirements.....	37
HRM048-051-054-058-060 / HLM068-072-075-078-		Cycle rate limit requirements.....	37
081 / HRP048-051-054-058-060 / HLP068-072-075-		Oil management logic recommendations	37
078-081 / HRH041-044-049-051-054-056 / HLH061-		Defrost logic recommendations	38
068 / HLJ072-075-083.....	11	Pump-down logic recommendations.....	38
HCM/HCP 094-109-120	12	Reduce moisture in the system	39
HJ091-106-121.....	13	Requirements.....	39
Electrical data, connections and wiring 15		Solutions	39
Motor voltage.....	15	INTEGRATION INTO SYSTEM	40
Wiring connections.....	15	Assembly line procedure	40
Three phase electrical characteristics	16	Compressor storage	40
Single phase electrical characteristics	18	Compressor holding charge.....	40
IP rating.....	20	Handling	40
LRA (Locked Rotor Amp).....	20	Piping assembly.....	41
MCC (Maximum Continuous Current).....	20	System pressure test and leak detection	41
Max Oper. A (Max operating current).....	20	Vacuum evacuation and moisture removal	42
Winding resistance.....	20	Refrigerant charging.....	42
Motor protection.....	20	Dielectric strength and insulation resistance tests	42
Phase sequence and reverse rotation protection...20		Commissioning	43
Electrical connections.....	21	Preliminary check.....	43
Nominal capacitor value and relays.....	21	Initial start-up	43
Approvals and certifications.....	22	System monitoring	43
Approvals and certificates.....	22	Oil level checking and top-up.....	43
Pressure equipment directive 2014/68/EU	22	Dismantle and disposal.....	44
Low voltage directive 2014/35/EU	22	ORDERING INFORMATION	45
Machines directive 2006/42/EC	22	Ordering information and packaging... 45	
Internal free volume	22	Packaging.....	45
Operating conditions	23	Packaging details.....	45
Refrigerant and lubricants.....	23	Compressor code numbers.....	46
SYSTEM DESIGN.....	24	R22 Single pack.....	46
Design piping.....	24	R22 Industrial pack.....	47
General requirements	24	R407C Single pack.....	48
Tandem requirements	25	R407C Industrial pack	49
Design compressor mounting	26	R410A Single pack.....	50
General requirements.....	26	R410A Industrial pack	51
Single requirements	26	Spare parts & accessories.....	52
Tandem requirements	26	Manage sound and vibration	27
Manage sound and vibration	27	Compressor sound radiation.....	27
Compressor sound radiation.....	27	Mechanical vibrations.....	28
Mechanical vibrations.....	28	Gas pulsation	28
Gas pulsation	28	Manage operating envelope	29
Manage operating envelope	29	Requirement	29
Requirement	29	R22, R407C Model variation T	29
R22, R407C Model variation T	29	R410A Model variation T.....	29
R410A Model variation T.....	29	R22, R410A Model variation U	30
R22, R410A Model variation U	30	High and low pressure protection.....	30
High and low pressure protection.....	30	System evaluation	31
System evaluation	31	Test, criteria and solutions.....	31
Test, criteria and solutions.....	31		

Danfoss scroll compressors are designed and manufactured according to the state of the art and to valid European and US regulations. Particular emphasis has been placed on safety and reliability. Related instructions are highlighted with the following icons:

 This icon indicates instructions to avoid safety risk.

 This icon indicates instructions to avoid reliability risk.

You are strongly advise to follow these instructions. For any deviation from the guidelines, please contact Danfoss Technical Support.

Features

Danfoss H-series scroll compressors are manufactured using the most advanced machining, assembly, and process control techniques. In design of both the compressor and the factory, very high standards of reliability

and process control were first priority. The result is a highly efficient product with the highest reliability obtainable, and a low sound level. The H-series compressors can be black or blue depending on the production site.

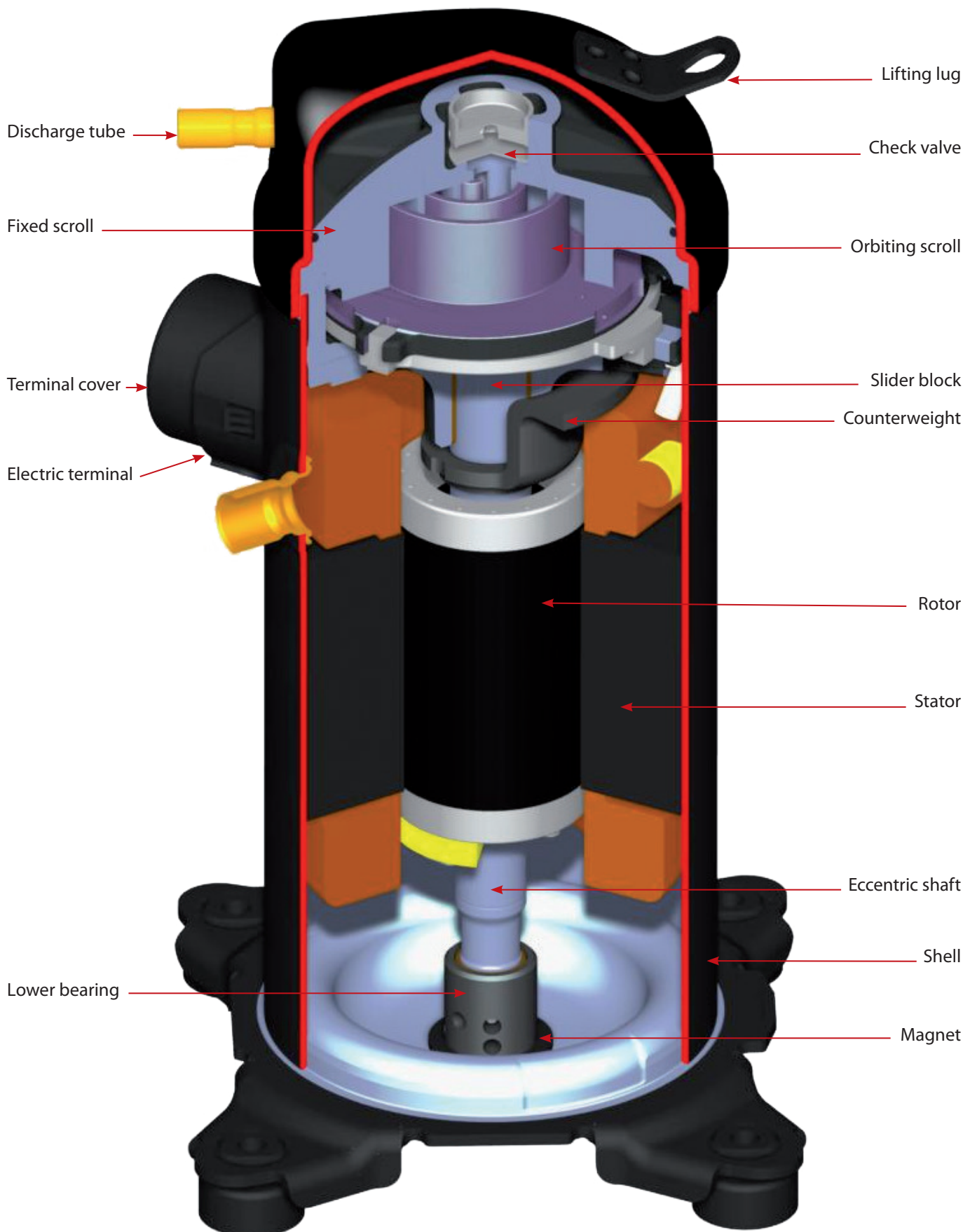

GENERAL INFORMATION
PRODUCT INFORMATION
SYSTEM DESIGN
INTEGRATION INTO SYSTEM
ORDERING INFORMATION

Compressor model designation

Danfoss H-series scroll compressor for R22/R407C/R410A is available as single compressor and can be assembled in tandem combinations. The example below presents the compressor

nomenclature which equals the technical reference as shown on the compressor nameplate. Code numbers for ordering are listed section "Ordering information and packaging".

Nomenclature

Type	Size	Motor	Features
HRH	036	U1L	P6

Application: _____
H: high temperature / air conditioning

Family: _____
C: commercial scroll
R: residential scroll
L: light commercial scroll

Refrigerant & lubricant: _____
M: R22, alkylbenzene lubricant
P: R407C, PVE lubricant
H: R410A, PVE lubricant
J: R410A, PVE lubricant

Nominal capacity: _____
 In thousand Btu/h at 60 Hz, ARI conditions

Model variation _____
T: design optimized for 7.2/54.4°C
U: design optimized for 7.2/37.8°C

Other features

	Oil sight glass	Oil equalisation	Oil drain	LP gauge port	Gas equalisation port
6	None	None	None	None	None
8	None	Brazed	None	None	Brazed

Tubing and electrical connections
P: brazed connections, spade terminals
C: brazed connections, screw terminals

Motor protection
L: internal motor protection

Motor voltage code
1: 208-230V/1~/60 Hz
2: 200-220V/3~/50Hz & 208-230V/3~/60 Hz
4: 380-415V/3~/50 Hz & 460V/3~/60 Hz
5: 220-240V/1~/50 Hz
7: 575V/ 3~/60 Hz
9: 380V/3~/60 Hz



Technical specifications

50-60 Hz data

Model	Nominal tons 60 Hz	Nominal cooling capacity		Power input	COP	E.E.R	Swept volume	Displacement	Oil charge	Net weight	
	TR	W	Btu/h	kW	W/W	Btu/h/W	cm ³ /rev	m ³ /h	dm ³	kg	
50Hz	HRM025T4	2	5 950	20 300	1.86	3.2	10.9	34.1	5.9	1.06	32
	HRM034U4	2.8	8 350	28 490	2.66	3.14	10.7	46.2	8.03	1.06	32
	HRM034T4	2.8	8 200	28 000	2.66	3.29	11.2	46.2	8.03	1.06	32
	HRM038U4	3.2	9 240	31 520	2.94	3.14	10.7	51.6	8.98	1.06	32
	HRM040U4	3.3	9 710	33 120	2.98	3.26	11.1	54.4	9.47	1.06	32
	HRM042U4	3.5	10 190	34 770	3.13	3.26	11.1	57.2	9.95	1.06	32
	HRM042T4	3.5	10 110	34 500	3.08	3.28	11.2	57.2	9.95	1.06	32
	HRM045U4	3.8	10 940	37 310	3.45	3.17	10.8	61.5	10.69	1.33	32
	HRM047U4	3.9	11 500	39 250	3.57	3.23	11	64.1	11.15	1.33	32
	HRM048U4	4	11 510	39 270	3.57	3.23	11	64.4	11.21	1.57	39
	HRM051T4	4.3	12 390	42 280	3.67	3.37	11.5	68.8	11.98	1.57	39
	HRM051U4	4.3	12 800	43 690	3.83	3.34	11.4	68.8	11.98	1.57	39
	HRM054U4	4.5	13 390	45 680	3.97	3.37	11.5	72.9	12.69	1.57	41
	HRM054T4	4.5	13 300	45 400	3.84	3.46	11.8	72.9	12.69	1.57	41
	HRM058U4	4.8	14 340	48 930	4.25	3.37	11.5	78.2	13.6	1.57	41
	HRM060T4	5	14 570	49 720	4.28	3.4	11.6	81	14.09	1.57	41
	HRM060U4	5	14 820	50 580	4.4	3.37	11.5	81	14.09	1.57	41
	HLM068T4	5.7	16 880	57 580	5	3.37	11.5	93.1	16.2	1.57	41
	HLM072T4	6	17 840	60 870	5.29	3.37	11.5	98.7	17.2	1.57	41
	HLM075T4	6.3	18 430	62 880	5.37	3.43	11.7	102.8	17.88	1.57	41
HLM081T4	6.8	19 890	67 880	5.8	3.43	11.7	110.9	19.3	1.57	41	
HCM094T4	7.8	23 060	78 670	6.8	3.39	11.6	126	21.93	2.66	47	
HCM109T4	9.1	26 690	91 070	7.77	3.43	11.7	148.8	25.89	2.66	47	
HCM120T4	10	29 130	99 390	8.51	3.42	11.7	162.4	28.26	2.66	47	
60Hz	HRM025T4	2	7 090	24 200	2.22	3.2	10.9	34.1	7.12	1.06	32
	HRM034U4	2.8	9 810	33 480	3.07	3.2	10.9	46.2	9.69	1.06	32
	HRM034T4	2.8	9 960	34 010	2.98	3.34	11.4	46.2	9.69	1.06	32
	HRM038U4	3.2	11 130	37 980	3.39	3.28	11.2	51.6	10.84	1.06	32
	HRM040U4	3.3	11 720	39 980	3.57	3.28	11.2	54.4	11.43	1.06	32
	HRM042U4	3.5	12 300	41 980	3.75	3.28	11.2	57.2	12.0	1.06	32
	HRM042T4	3.5	12 160	41 510	3.64	3.34	11.4	57.2	12.0	1.06	32
	HRM045U4	3.8	13 180	44 980	4.01	3.28	11.2	61.5	12.9	1.33	32
	HRM047U4	3.9	13 920	47 490	4.22	3.3	11.3	64.1	13.46	1.33	32
	HRM048U4	4	13 830	47 180	4.25	3.25	11.1	64.4	13.53	1.57	39
	HRM051T4	4.3	15 030	51 270	4.46	3.37	11.5	68.8	14.46	1.57	39
	HRM051U4	4.3	15 030	51 280	4.46	3.37	11.5	68.8	14.46	1.57	39
	HRM054U4	4.5	15 730	53 680	4.62	3.4	11.6	72.9	15.32	1.57	41
	HRM054T4	4.5	15 820	54 000	4.53	3.49	11.9	72.9	15.32	1.57	41
	HRM058U4	4.8	16 930	57 780	5.02	3.37	11.5	78.2	16.41	1.57	41
	HRM060T4	5	17 490	59 670	5.14	3.4	11.6	81	17.0	1.57	41
	HRM060U4	5	17 490	59 680	5.19	3.37	11.5	81	17.0	1.57	41
	HLM068T4	5.7	20 190	68 880	5.94	3.4	11.6	93.1	19.55	1.57	41
	HLM072T4	6	21 330	72 770	6.27	3.4	11.6	98.7	20.76	1.57	41
	HLM075T4	6.3	22 120	75 480	6.45	3.43	11.7	102.8	21.58	1.57	41
HLM081T4	6.8	23 880	81 470	6.96	3.43	11.7	110.9	23.29	1.57	41	
HCM094T4	7.8	27 690	94 470	8.07	3.43	11.7	126	26.47	2.66	47	
HCM109T4	9.1	32 020	109 270	9.33	3.43	11.7	148.8	31.25	2.66	47	
HCM120T4	10	34 950	119 260	10.22	3.42	11.7	162.4	34.11	2.66	47	

① Displacement at nominal speed: 2900 rpm at 50 Hz, 3500 rpm at 60 Hz

② Net weight with oil charge

TR = Ton of Refrigeration
COP = Coefficient Of Performance
EER = Energy Efficiency Ratio

Standard rating conditions: ARI standard
Refrigerant: R22
Superheat: 11.1 K

Evaporating temperature: 7.2 °C
Condensing temperature: 54.4 °C
Sub-cooling: 8.3 K

All performance test data after run-in 72hr

Subject to modification without prior notification

Data given for motor code 4 compressor, for full data details and capacity tables refer to Online Datasheet Generator: www.danfoss.com/odsg

Technical specifications

50-60 Hz data

Model	Nominal tons 60 Hz	Nominal cooling capacity		Power input	COP	E.E.R	Swept volume	Displacement	Oil charge	Net weight	
	TR	W	Btu/h	kW	W/W	Btu/h/W	cm ³ /rev	m ³ /h	dm ³	kg	
50Hz	HRP025T4	2.0	5730	19 570	1.86	3.08	10.5	34.1	5.90	1.06	32
	HRP034T4	2.8	7 940	27 080	2.68	2.96	10.1	46.2	8.03	1.06	32
	HRP038T4	3.2	8 840	30 150	2.82	3.14	10.7	51.6	8.98	1.06	32
	HRP040T4	3.3	9 110	31 080	3.14	2.90	9.9	54.4	9.47	1.06	32
	HRP042T4	3.5	9 580	32 680	3.30	2.90	9.9	57.2	9.95	1.06	32
	HRP045T4	3.8	10 810	36 890	3.58	3.02	10.3	61.5	10.69	1.33	32
	HRP047T4	3.9	11 130	37 980	3.69	3.02	10.3	64.1	11.15	1.33	32
	HRP048T4	4.0	11 100	37 880	3.35	3.31	11.3	64.4	11.21	1.57	39
	HRP051T4	4.3	12 120	41 370	3.83	3.17	10.8	68.8	11.98	1.57	39
	HRP054T4	4.5	12 570	42 880	3.97	3.17	10.8	72.8	12.66	1.57	41
	HRP058T4	4.8	13 470	45 970	4.25	3.17	10.8	78.2	13.60	1.57	41
	HRP060T4	5.0	13 860	47 280	4.26	3.25	11.1	81.0	14.09	1.57	41
	HLP068T4	5.7	15 700	53 560	5.10	3.08	10.5	93.1	16.20	1.57	41
	HLP072T4	6.0	16 620	56 740	5.30	3.14	10.7	98.7	17.17	1.57	41
	HLP075T4	6.3	18 040	61 550	5.54	3.26	11.1	102.8	17.88	1.57	41
	HLP081T4	6.8	19 480	66 510	5.99	3.25	11.1	110.9	19.30	1.57	41
	HCP094T4	7.8	21 590	73 660	6.63	3.26	11.1	126.0	21.93	2.66	47
	HCP109T4	9.1	26 060	88 950	7.93	3.28	11.2	148.8	25.89	2.66	47
	HCP120T4	10.0	28 150	96 080	8.88	3.17	10.8	162.4	28.26	2.66	47
60Hz	HRP025T4	2.0	6880	23 490	2.22	3.11	10.6	34.1	7.12	1.06	32
	HRP034T4	2.8	9580	32 700	3.20	3.00	10.2	46.2	9.69	1.06	32
	HRP038T4	3.2	10 670	36 410	3.36	3.18	10.8	46.2	10.84	1.06	32
	HRP040T4	3.3	10 990	37 510	3.70	2.97	10.1	54.4	11.43	1.06	32
	HRP042T4	3.5	11 560	39 460	3.93	2.94	10.0	57.2	12.01	1.06	32
	HRP045T4	3.8	13 050	44 540	4.27	3.06	10.4	61.5	12.9	1.33	32
	HRP047T4	3.9	12 690	43 300	4.24	3.00	10.2	64.1	13.46	1.33	32
	HRP048T4	4.0	13 400	45 740	3.99	3.36	11.5	64.4	13.53	1.57	39
	HRP051T4	4.3	14 380	49080	4.46	3.23	11.0	68.8	14.46	1.57	39
	HRP054T4	4.5	15 120	51 770	4.73	3.21	11.0	72.8	15.28	1.57	41
	HRP058T4	4.8	16 260	55 510	5.07	3.17	10.8	78.2	16.41	1.57	41
	HRP060T4	5.0	16 720	57 010	5.07	3.30	11.3	81.0	17.01	1.57	41
	HLP068T4	5.7	18 950	64 660	6.08	3.12	10.6	93.1	19.55	1.57	41
	HLP072T4	6.0	20 060	68 480	6.32	3.17	10.8	98.7	20.72	1.57	41
	HLP075T4	6.3	21 770	74 330	6.60	3.30	11.3	102.8	21.58	1.57	41
	HLP081T4	6.8	23 380	79 810	7.14	3.27	11.2	110.9	23.29	1.57	41
	HCP094T4	7.8	26 060	88 950	7.90	3.30	11.3	126.0	26.47	2.66	47
	HCP109T4	9.1	31 450	107 350	9.46	3.32	11.3	148.8	31.25	2.66	47
	HCP120T4	10.0	33 970	115 960	10.59	3.21	11.0	162.4	34.11	2.66	47

① Displacement at nominal speed: 2900 rpm at 50 Hz, 3500 rpm at 60 Hz

② Net weight with oil charge

TR = Ton of Refrigeration

COP = Coefficient Of Performance

EER = Energy Efficiency Ratio

Standard rating conditions: ARI standard

Refrigerant: R407C

Superheat: 11.1 K

Evaporating temperature: 7.2 °C

Condensing temperature: 54.4 °C

Sub-cooling: 8.3 K

All performance test data after run-in 72hr

Subject to modification without prior notification

Data given for motor code 4 compressor, for full data details and capacity tables refer to Online Datasheet Generator: www.danfoss.com/odsg

Technical specifications

50-60 Hz data

Model	Nominal tons	Nominal cooling capacity		Power input	COP	E.E.R	Swept volume	Displacement	Oil charge	Net weight	
	60 Hz	W	Btu/h	kW	W/W	Btu/h/W	cm ³ /rev	m ³ /h	dm ³	kg	
50Hz	HRH029U4	2.4	7 120	24 310	2.43	2.93	10	27.8	4.84	1.06	32
	HRH031U4	2.6	7 530	25 710	2.67	2.82	9.62	29.8	5.19	1.06	32
	HRH032U4	2.7	7 670	26 170	2.75	2.79	9.51	30.6	5.33	1.06	32
	HRH034U4	2.8	8 500	29 000	2.9	2.93	10	33.3	5.75	1.06	32
	HRH036U4	3	8 820	30 110	3.13	2.82	9.62	34.7	6.04	1.06	32
	HRH038U4	3.2	9 250	31 560	3.35	2.76	9.41	36.5	6.36	1.06	39
	HRH040U4	3.3	10 200	34 810	3.58	2.85	9.72	39.6	6.9	1.33	39
	HRH041U4	3.3	10 050	34 300	3.43	2.93	10	39.3	6.8	1.57	39
	HRH044U4	3.7	10 830	36 940	3.92	2.76	9.41	42.6	7.41	1.57	39
	HRH047U4	3.9	11 340	38 700	3.87	2.93	10.01	44.4	7.73	1.57	39
	HRH049U4	4.1	12 110	41 320	4.04	2.99	10.22	47.4	8.24	1.57	39
	HRH051U4	4.3	12 860	43 890	4.21	3.05	10.42	49.3	8.58	1.57	41
	HRH054U4	4.5	13 340	45 510	4.41	3.02	10.32	52.1	9.07	1.57	41
	HRH056U4	4.7	13 830	47 200	4.58	3.02	10.31	54.1	9.42	1.57	41
	HLH061T4	5.1	15 210	51 880	4.89	3.11	10.61	57.8	10.1	1.57	41
	HLH068T4	5.7	16 880	57 610	5.26	3.21	10.96	64.4	11.21	1.57	41
	HLJ072T4	6	17 840	60 900	5.56	3.21	11	68	11.82	1.57	41
	HLJ075T4	6.3	18 600	63 490	5.77	3.22	11	70.8	12.32	1.57	41
	HLJ083T4	6.9	20 420	69 690	6.28	3.25	11.1	78.1	13.59	1.57	41
	H CJ091T4	7.5	22 380	76 360	7.03	3.18	10.87	86.9	15.11	2.46	49
H CJ106T4	8.8	26 050	88 880	8.07	3.23	11.01	101.6	17.68	2.46	49	
H CJ121T4	10	29 720	101 400	9.22	3.22	11	116.4	20.24	2.46	49	
60Hz	HRH029U4	2.4	8 500	29 000	2.84	2.99	10.2	27.8	5.84	1.06	32
	HRH031U4	2.6	9 080	30 990	3.04	2.99	10.2	29.8	6.26	1.06	32
	HRH032U4	2.7	9 380	31 990	3.1	3.02	10.3	30.6	6.43	1.06	32
	HRH034U4	2.8	10 110	34 510	3.38	2.99	10.2	33.3	6.94	1.06	32
	HRH036U4	3	10 370	35 390	3.47	2.99	10.2	34.7	7.3	1.06	32
	HRH038U4	3.2	11 100	37 890	3.79	2.93	10	36.5	7.67	1.06	39
	HRH040U4	3.3	12 160	41 490	4.03	3.02	10.3	39.6	8.3	1.33	39
	HRH041U4	3.3	12 100	41 300	4.05	2.99	10.2	39.3	8.3	1.57	39
	HRH044U4	3.7	13 010	44 390	4.31	3.02	10.3	42.6	8.95	1.57	39
	HRH047U4	3.9	13 630	46 510	4.56	2.99	10.2	44.4	9.33	1.57	39
	HRH049U4	4.1	14 360	48 990	4.66	3.08	10.5	47.4	9.95	1.57	39
	HRH051U4	4.3	15 180	51 780	4.84	3.14	10.7	49.3	10.36	1.57	41
	HRH054U4	4.5	15 970	54 480	5.14	3.11	10.6	52.1	10.94	1.57	41
	HRH056U4	4.7	16 670	56 880	5.36	3.11	10.6	54.1	11.36	1.57	41
	HLH061T4	5.1	18 050	61 580	5.7	3.17	10.8	57.8	12.13	1.57	41
	HLH068T4	5.7	20 130	68 670	6.3	3.2	10.9	64.4	13.52	1.57	41
	HLJ072T4	6	21 240	72 500	6.65	3.19	10.9	68	14.27	1.57	41
	HLJ075T4	6.3	22 320	76 190	6.86	3.25	11.1	70.8	14.87	1.57	41
	HLJ083T4	6.9	24 340	83 090	7.55	3.22	11	78.1	16.4	1.57	41
	H CJ091T4	7.5	27 140	92 600	8.37	3.24	11.07	86.9	18.24	2.46	49
H CJ106T4	8.8	31 670	108 050	9.67	3.28	11.18	101.6	21.34	2.46	49	
H CJ121T4	10	35 940	122 620	11.07	3.25	11.08	116.4	24.43	2.46	49	

① Displacement at nominal speed: 2900 rpm at 50 Hz, 3500 rpm at 60 Hz

② Net weight with oil charge

TR = Ton of Refrigeration

COP = Coefficient Of Performance

EER = Energy Efficiency Ratio

Standard rating conditions: ARI standard

Refrigerant: R410A

Superheat: 11.1 K

Evaporating temperature: 7.2 °C

Condensing temperature: 54.4 °C

Sub-cooling: 8.3 K

All performance test data after run-in 72hr

Subject to modification without prior notification

Data given for motor code 4 compressor, for full data details and capacity tables refer to Online Datasheet Generator: www.danfoss.com/odsg

Dimensions

HRM025-032-034-038-040-042 / HRP025-034-038-040-042 / HRH029-031-032-034-036-038 / HRM-045-047 / HRP-045-047 / HRH039-040

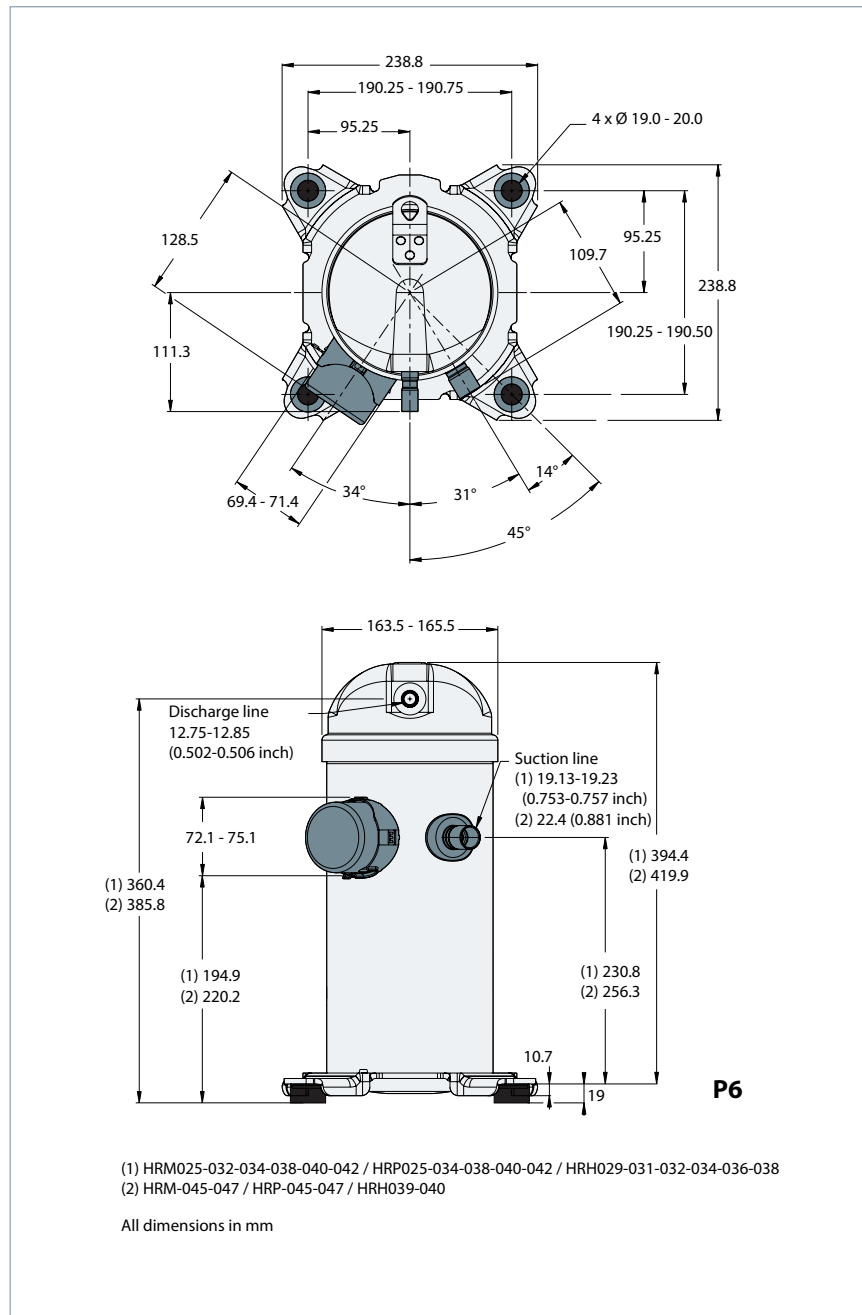

Terminal box

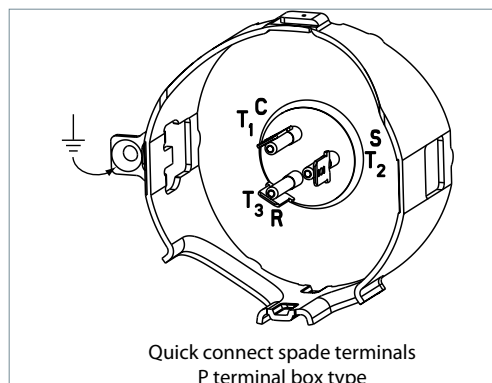

Mounting grommet

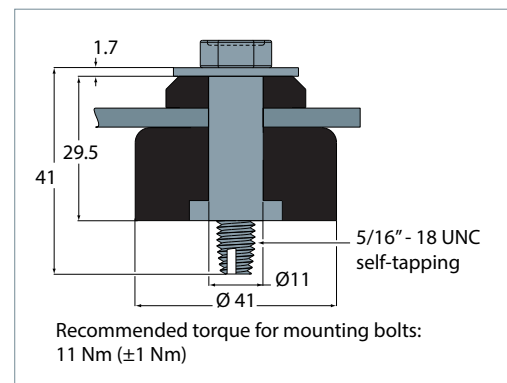

Refer to section 44 for overview of shipped mounting accessories

Dimensions

HRM048-051-054-058-060 / HLM068-072-075-078-081 / HRP048-051-054-058-060 /
HLP068-072-075-078-081 / HRH041-044-049-051-054-056 / HLH061-068 / HLJ072-075-083

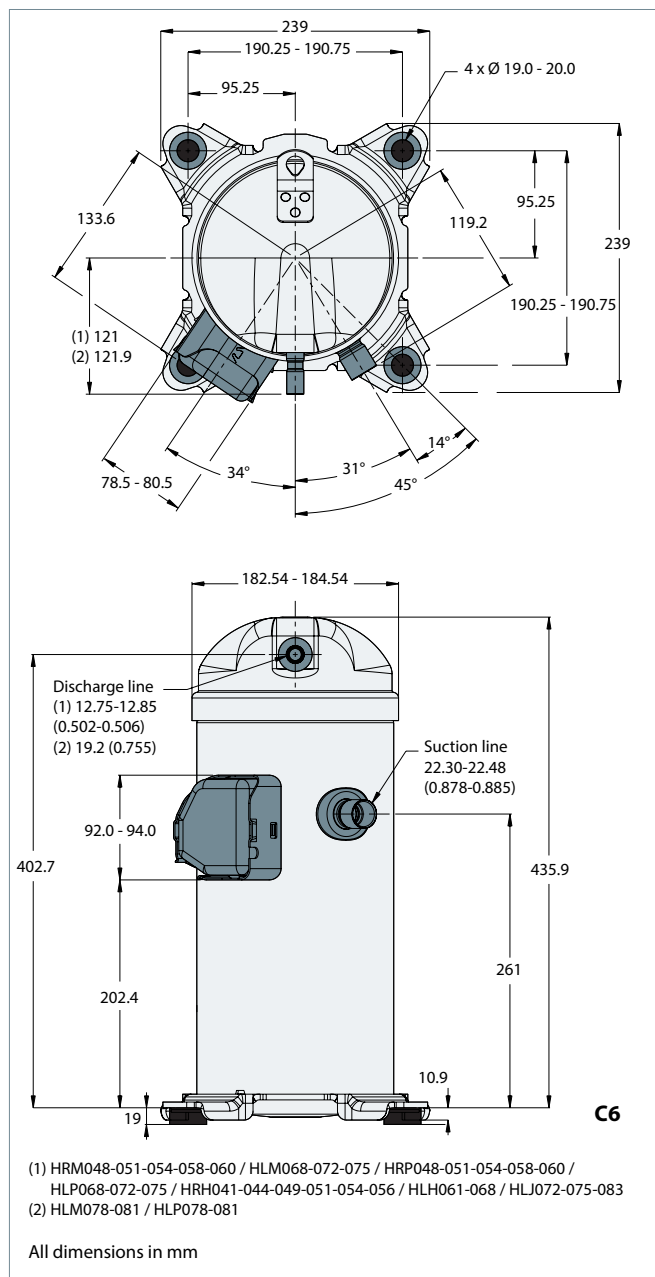
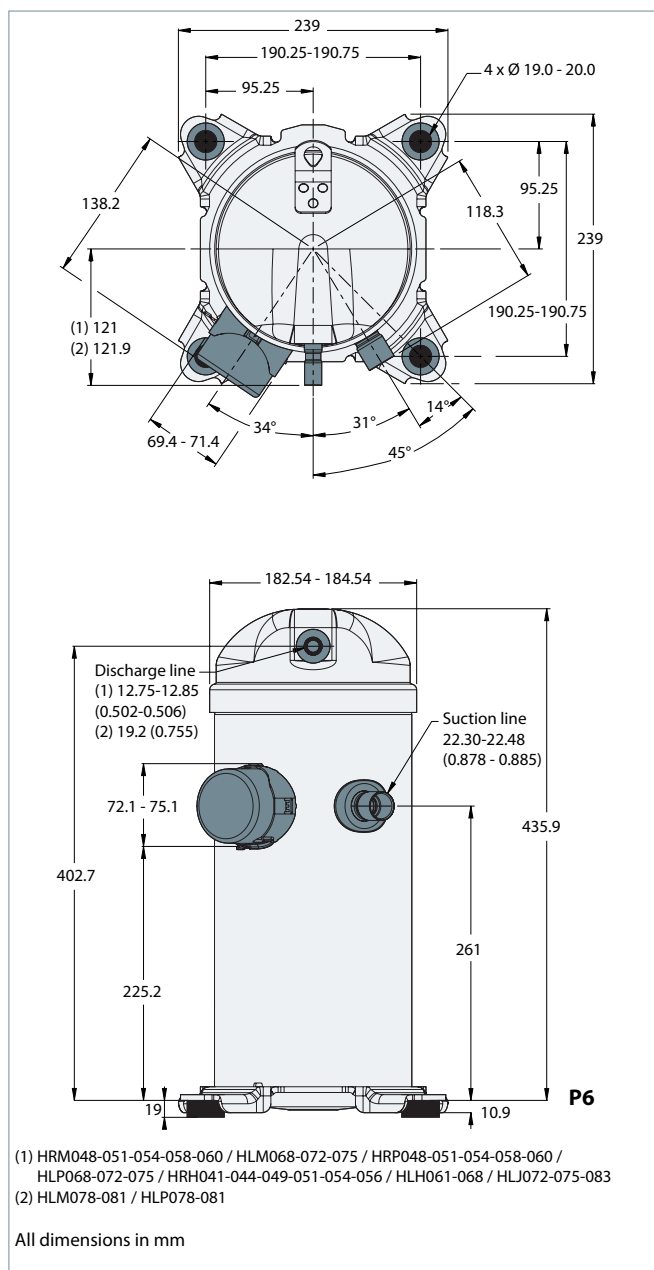

Terminal boxes

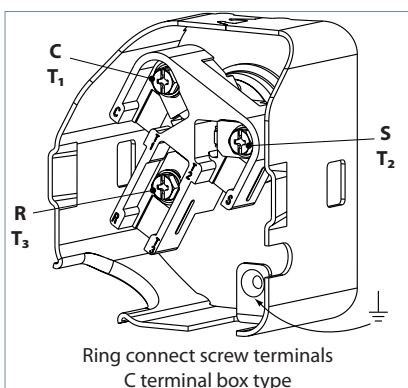
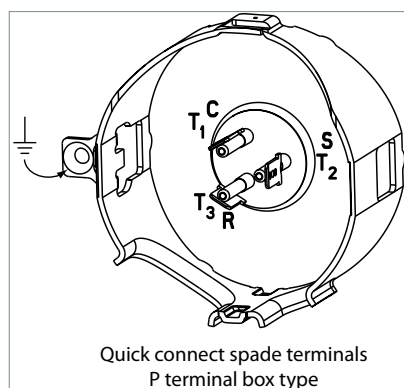

Mounting grommet

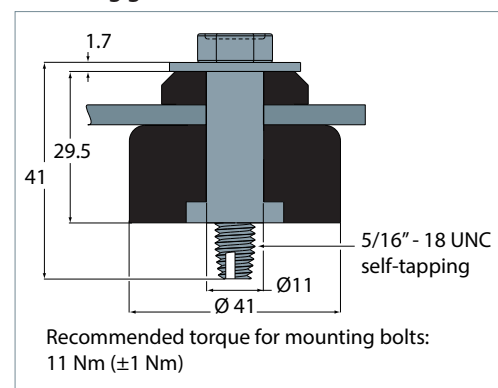

Refer to section 44 for overview of shipped mounting accessories

Dimensions

HCM/HCP 094-109-120

GENERAL INFORMATION

PRODUCT INFORMATION

SYSTEM DESIGN

INTEGRATION INTO SYSTEM

ORDERING INFORMATION

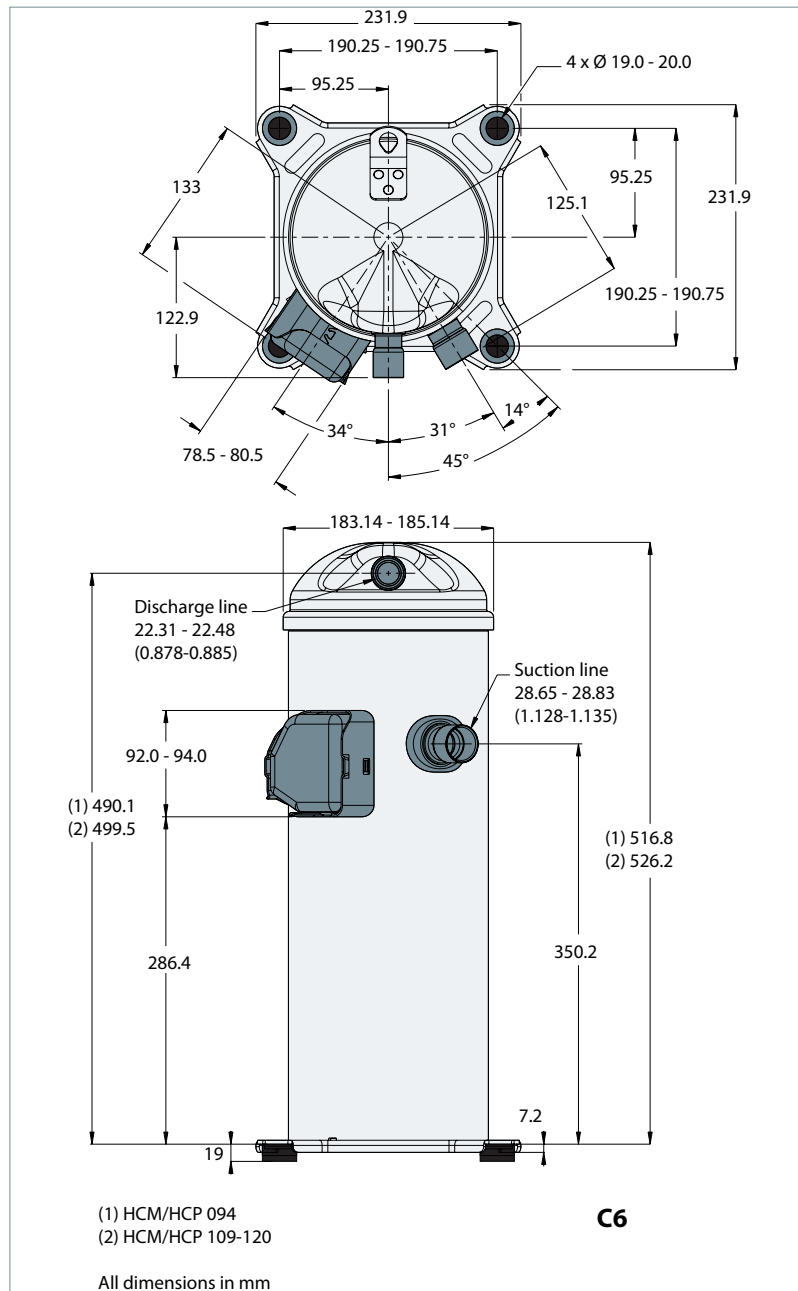

Terminal box

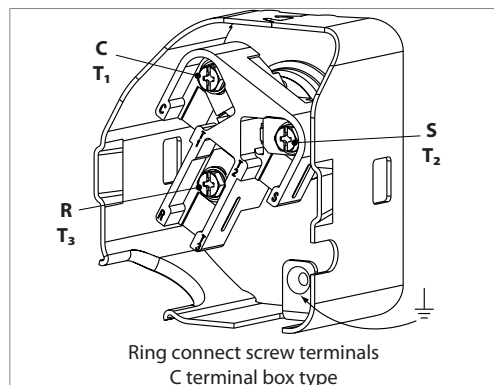

Mounting grommet

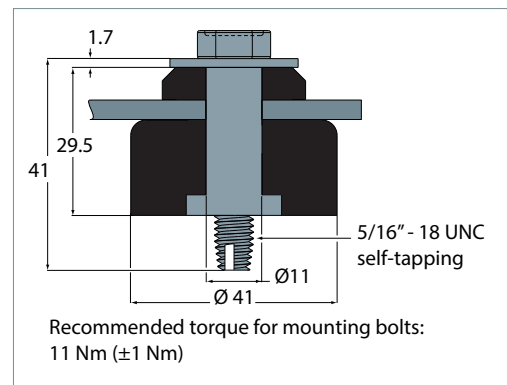

Refer to section 44 for overview of shipped mounting accessories

Dimensions

HCJ091-106-121

PRODUCT INFORMATION

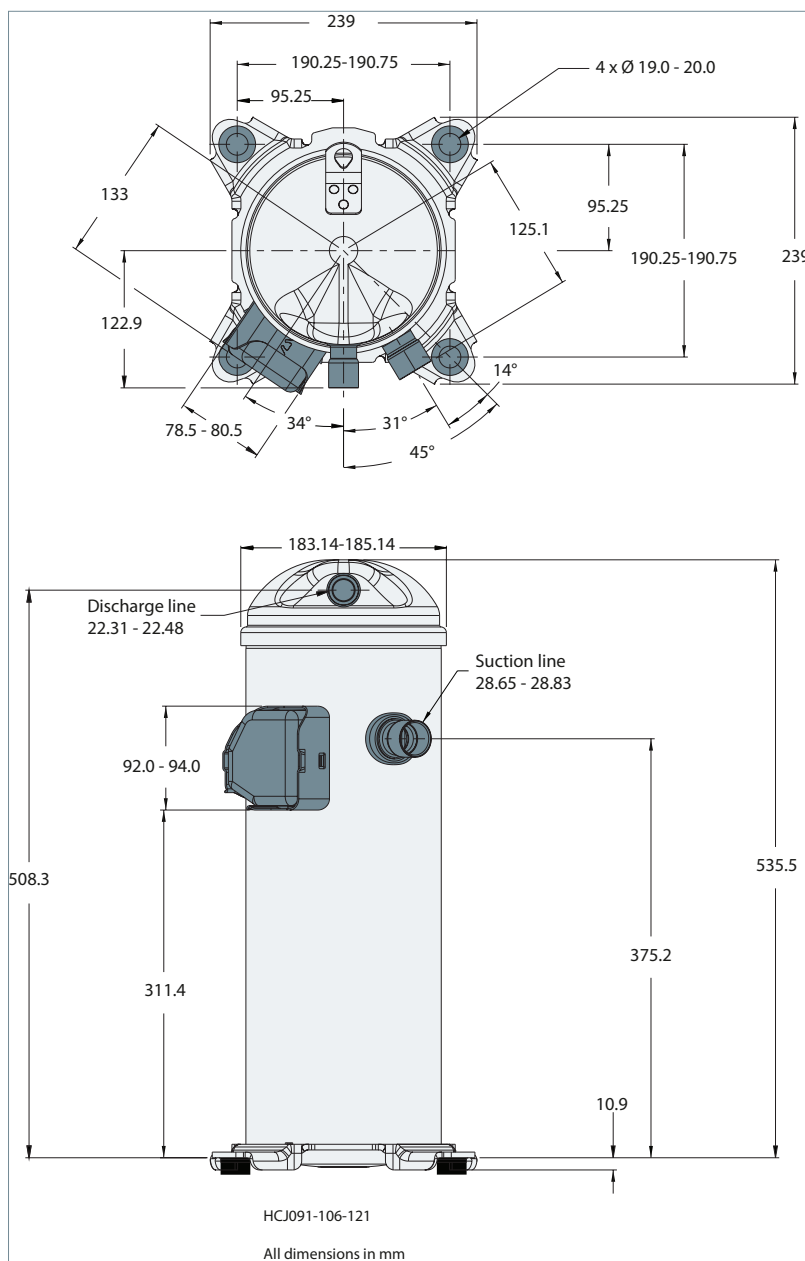

Terminal box

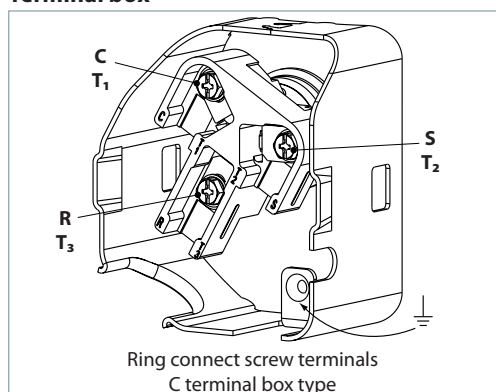

Mounting grommet

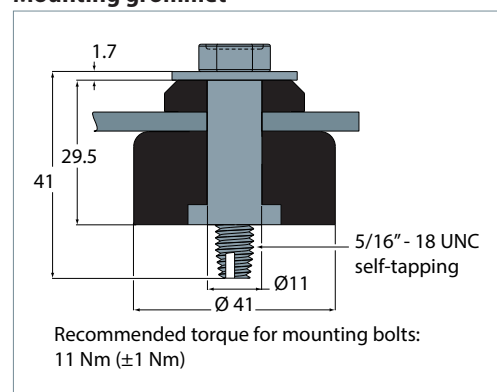

Refer to section 44 for overview of shipped mounting accessories

GENERAL INFORMATION

PRODUCT INFORMATION

SYSTEM DESIGN

INTEGRATION INTO SYSTEM

ORDERING INFORMATION

Dimensions

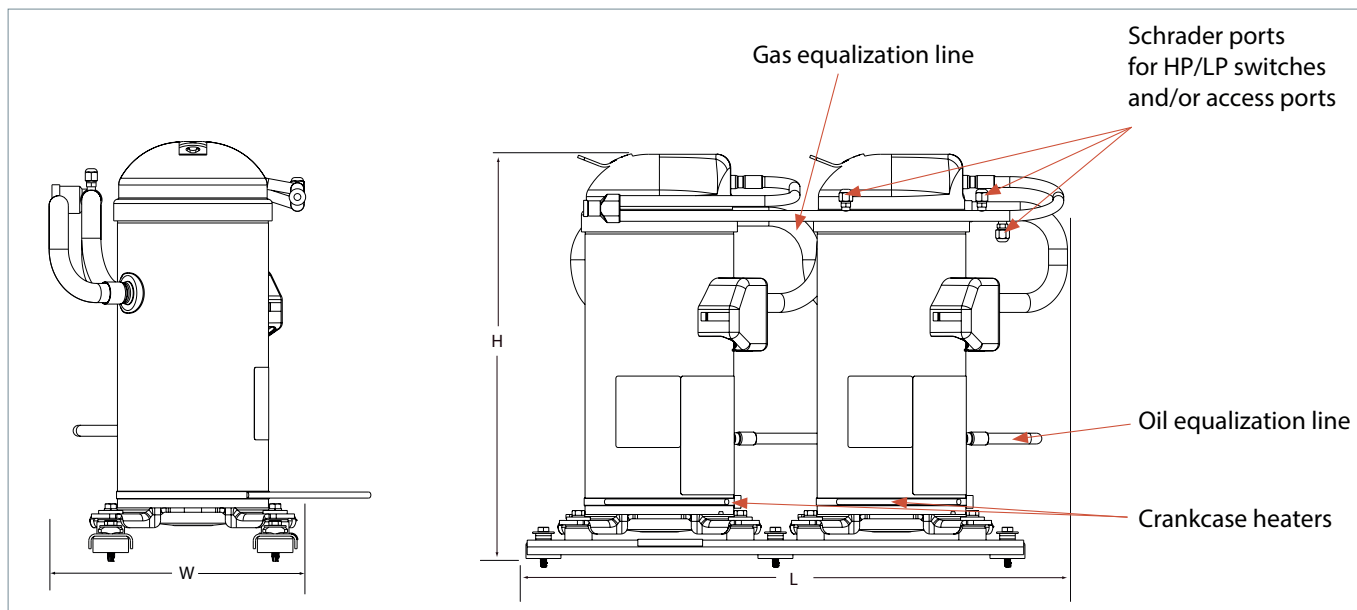

By default, H series tandems are not factory-built, just provide tandem version compressors (feature 8).

Tandems to be achieved by assembly of individual compressors, if they are the feature 8 compressor.

Tandem model	Composition	L (mm)	H(mm)	Wmm)	Outline drawing number
TLJ082	HRH041 + HRH041	636	476	297	8556080
TLJ098	HRH049 + HRH049	636	476	297	8556080
TLJ122	HLH061 + HLH061	636	476	297	8556080
TLJ136	HLH068 + HLH068	636	476	297	8556080
TLJ144	HLJ072 + HLJ072	636	476	297	8556080
TLJ166	HLJ083 + HLJ083	636	476	297	8556080
TCJ181	H CJ091 + H CJ091	676	575	312	8556153
TCJ211	H CJ106 + H CJ106	676	575	312	8556153
TCJ241	H CJ121 + H CJ121	676	575	312	8556153

Electrical data, connections and wiring

Motor voltage

Danfoss scroll compressors H Series are available in four different motor voltages as listed below.

Motor voltage code	Code 1	Code 2	Code 4	Code 5	Code 7	Code 9
Nominal voltage 50 Hz	-	200-220 V - 3 ph	380-415V - 3 ph	220-240 V -1 ph	-	-
Voltage range 50 Hz	-	180 - 242 V	342 - 457 V	198 - 264 V	-	-
Nominal voltage 60 Hz	208-230 V - 1ph	208-230 V - 3 ph	460 V - 3 ph	-	575 V - 3 ph	380 V - 3 ph
Voltage range 60 Hz	187 - 253 V	187 - 253 V	414 - 506 V	-	517 - 632 V	342 - 418 V

The maximum allowable voltage imbalance is 2%. Voltage imbalance causes high amperage over one or several phases, which in turn leads

to overheating and possible motor damage. Voltage imbalance is given by the formula:

$$\% \text{ voltage unbalance: } \frac{|\text{Vavg} - \text{V1-2}| + |\text{Vavg} - \text{V1-3}| + |\text{Vavg} - \text{V2-3}|}{2 \times \text{Vavg}} \times 100$$

Vavg = Mean voltage of phases 1, 2 and 3
V1-2 = Voltage between phases 1 and 2

V1-3 = Voltage between phases 1 and 3
V2-3 = Voltage between phases 2 and 3.

Wiring connections

Danfoss Scroll Compressors H-series will only compress gas while rotating counter-clockwise (when viewed from the compressor top). Since single-phase motors will start and run in only one direction, reverse rotation is not a major consideration. Three-phase motors, however, will start and run in either direction, depending on the phase angles of the supplied power. Care must be taken during installation to ensure that the compressor operates in the correct direction (see "Phase sequence and reverse rotation protection").

Electrical box cover must be fitted and cable gland or similar protection component must be used on electrical box's knockouts before energizing the compressor to against accidental contact with electrical parts inside.

The drawings below show electrical terminal labelling and should be used as a reference when wiring the compressor. For three phase applications, the terminals are labelled T1, T2, and T3. For single-phase applications the terminals are labelled C (common), S (start), and R (run).

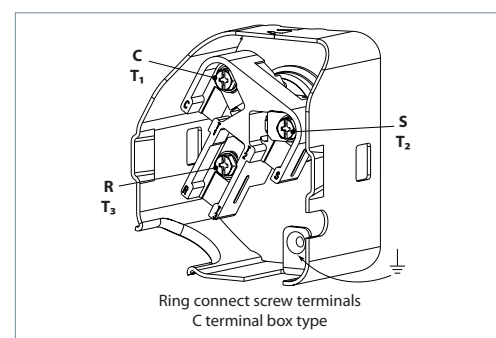
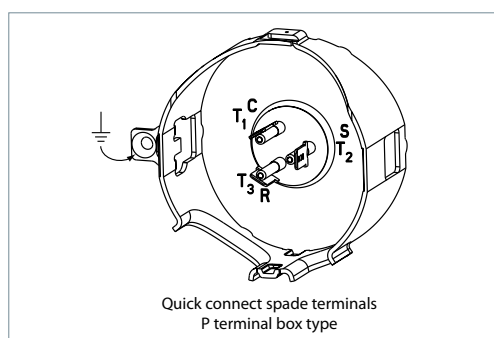

Terminal cover mounting

The terminal cover and gasket should be installed prior to operation of the compressor. The terminal cover has two outside tabs, 180 degrees apart, that engage the terminal fence.

When installing the cover, check that it is not pinching the lead wires. Both the inside of the terminal cover and the gasket have labels for the terminal pins: C (common), R (run), and S (start).

Terminal cover removal

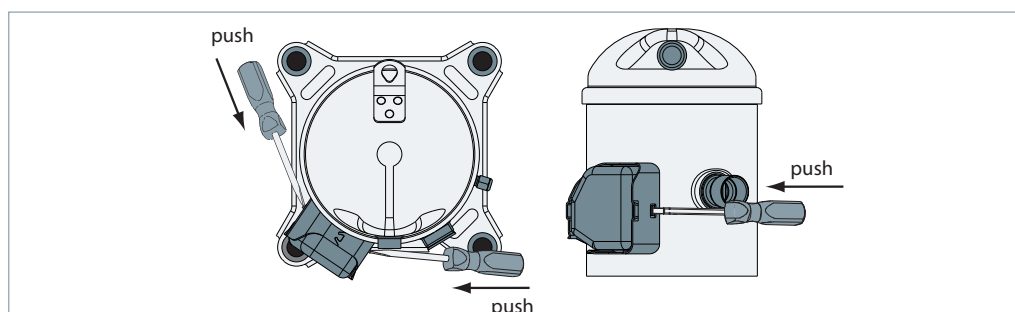

Three phase electrical characteristics

Compressor model	LRA	MCC	Max. operating current	Winding resistance (Ohm)			
	A	A	A	L2-L3	L1-L3	L2-L1	
Motor voltage code 2 200-220 V / 3 ph / 50 Hz 208-230 V / 3 ph / 60 Hz	HRM034U2	95	17.5	13.6	1.18	0.87	1.18
	HRM038U2	95	19	14.8	1.18	0.87	1.18
	HRM040U2	95	20	15.5	1.18	0.87	1.18
	HRM042U2	95	22	16.6	1.18	0.87	1.18
	HRM045U2	115	25	18.9	0.98	0.73	0.98
	HRM047U2	115	25	20.1	0.98	0.73	0.98
	HRM054U2	123	27	21.7	0.59	0.59	0.59
	HRM058U2	123	27	22.7	0.59	0.59	0.59
	HRM060U2	123	28	23.5	0.59	0.59	0.59
	HLM068T2	170	30	26.6	0.48	0.48	0.46
	HLM072T2	170	30	28.2	0.48	0.48	0.46
	HLM075T2	190	35	31.6	0.42	0.42	0.42
	HLM081T2	190	39	35.2	0.42	0.42	0.42
	HCM094T2	190	40	36.1	0.37	0.37	0.37
Motor voltage code 4 380-415 V / 3ph / 50 Hz 460 V / 3 ph / 60 Hz	HCM109T2	235	46	40.7	0.33	0.32	0.32
	HCM120T2	250	55	47.6	0.30	0.29	0.29
	HRM025T4	30	7	4.9	6.72	4.95	6.72
	HRM034T4	45	9.5	6.8	4.66	3.42	4.66
	HRM034U4	45	9.5	6.8	4.66	3.42	4.66
	HRM038T4	45	9.5	7.6	4.66	3.42	4.66
	HRM038U4	45	10	7.2	4.66	3.42	4.66
	HRM040U4	45	10	7.5	4.66	3.42	4.66
	HRM042T4	45	11	8.3	4.66	3.42	4.66
	HRM042U4	45	11	8.3	4.66	3.42	4.66
	HRM045U4	50	12	8.9	3.87	2.85	3.87
	HRM047T4	50	12	9.3	3.87	2.85	3.87
	HRM047U4	50	12	9.3	3.87	2.85	3.87
	HRM048U4	60	12.5	9.4	2.65	2.61	2.60
Motor voltage code 7 575 V / 3ph / 60 Hz	HRM051T4	60	13	9.8	2.65	2.62	2.60
	HRM054T4	70	12.5	10.5	2.37	2.35	2.34
	HRM054U4	70	13.1	11.0	2.37	2.35	2.34
	HRM058U4	70	15	11.3	2.37	2.35	2.34
	HRM060T4	70	15	11.7	2.37	2.36	2.35
	HRM060U4	70	15	11.7	2.37	2.35	2.34
	HLM068T4	82	15	12.4	1.80	1.88	1.87
	HLM072T4	82	15	14.1	2.20	2.20	2.20
	HLM075T4	100	16	15.0	2.20	2.20	2.20
	HLM078T4	87	16	15.6	1.67	1.69	1.72
	HLM081T4	87	17	16.6	1.82	1.82	1.83
	HCM094T4	95	21	18.1	1.48	1.48	1.48
	HCM109T4	110	24	20.3	1.30	1.28	1.34
	HCM120T4	140	25	23.9	1.13	1.11	1.10
Motor voltage code 9 380 V / 3ph / 60 Hz	HRM038U7	38	8.5	6.2	7.34	5.38	7.34
	HRM042U7	38	9	6.6	7.34	5.38	7.34
	HRM045U7	40	9.5	7.1	6.09	4.47	6.09
	HRM047U7	40	10	7.4	6.09	4.47	6.09
	HRM054U7	53	11	8.4	4.12	4.06	4.03
	HRM058U7	53	11.5	8.8	4.12	4.06	4.03
	HRM060U7	53	11.5	9.1	4.04	3.97	3.94
	HLM072T7	63.6	11.5	11.3	2.98	2.83	2.87
	HLM075T7	72	13.5	11.8	2.51	2.48	2.53
	HCM094T7	75	16	14.4	2.30	2.31	2.34
Motor voltage code 2 200-220 V / 3 ph / 50 Hz 208-230 V / 3 ph / 60 Hz	HRM034T9	52	12	8.3	3.01	2.20	3.01
	HRM038T9	52	12	9.3	3.01	2.20	3.01
	HRM042T9	52	12.5	10.1	3.01	2.20	3.01
	HRM047T9	59.6	8.3	11.3	2.51	1.84	2.51
	HRM054T9	81	16.5	12.7	1.49	1.46	1.48
	HRM060T9	81	17	14.2	1.03	1.02	1.03
	HLM072T9	96	20	17.0	1.27	1.25	1.28
	HLM081T9	110	19	20.4	1.13	1.08	1.10
	HCM094T9	135	25	21.9	0.93	0.91	0.93
	HCM120T9	135	27	23.9	0.87	0.88	0.89
Motor voltage code 2 200-220 V / 3 ph / 50 Hz 208-230 V / 3 ph / 60 Hz	HRP025T2		14.5	9.6	1.67	1.23	1.67
	HRP038T2	95	19	14.8	1.18	0.87	1.18
	HRP040T2	95	20	15.5	1.18	0.87	1.18
	HRP047T2	115	25	20.1	0.98	0.73	0.98
	HRP051T2	120	26	20.1	0.68	0.67	0.67
	HRP058T2	123	27	22.7	0.59	0.59	0.59
	HRP060T2	123	28	23.5	0.59	0.59	0.59
	HLP068T2	170	32	27.3	0.48	0.48	0.46
	HLP072T2	170	33	28.2	0.48	0.48	0.46
	HLP075T2	190	35	31.6	0.41	0.40	0.41
	HLP078T2	190	37	33.4	0.43	0.43	0.44
	HLP081T2	190	39	35.2	0.43	0.43	0.44
	HCP094T2	190	40	36.1	0.37	0.37	0.37
	HCP109T2	235	46	40.7	0.33	0.32	0.32
HCP120T2	250	55	47.6	0.30	0.29	0.29	

Three phase electrical characteristics

Compressor model	LRA	MCC	Max. operating current	Winding resistance (Ohm)			
	A	A	A	L2-L3	L1-L3	L2-L1	
Motor voltage code 4 380-415 V / 3ph / 50 Hz 460 V / 3 ph / 60 Hz	HRP025T4	30	7	4.9	6.72	4.95	6.72
	HRP034T4	45	9.5	6.8	4.66	3.42	4.66
	HRP038T4	45	11	7.9	4.66	3.42	4.66
	HRP040T4	45	12	8.6	4.66	3.42	4.66
	HRP042T4	45	11	8.3	4.66	3.42	4.66
	HRP045T4	50	12	8.9	3.87	2.85	3.87
	HRP047T4	50	12	9.3	3.87	2.85	3.87
	HRP048T4	60	12	9.0	2.65	2.61	2.60
	HRP051T4	60	13	9.8	2.65	2.62	2.60
	HRP054T4	70	12.5	10.5	2.37	2.37	2.37
	HRP058T4	70	14	11.3	2.36	2.33	2.32
	HRP060T4	70	14	11.7	2.37	2.36	2.35
	HLP068T4	82	15	12.4	2.20	2.20	2.20
	HLP072T4	87	15	14.1	2.20	2.20	2.20
	HLP075T4	100	17	15.0	2.20	2.20	2.20
	HLP078T4	87	16	15.6	1.67	1.69	1.72
	HLP081T4	87	17	16.6	1.90	1.88	1.89
	HCP094T4	95	21	18.1	1.48	1.48	1.48
HCP109T4	110	24	20.3	1.30	1.28	1.34	
HCP120T4	140	25	23.9	1.13	1.11	1.10	
Motor voltage code 2 200-220 V / 3 ph / 50 Hz 208-230 V / 3 ph / 60 Hz	HRH029U2	95	20	14.8	1.18	0.87	1.18
	HRH031U2	95	20	15.8	1.18	0.87	1.18
	HRH032U2	95	20	16.3	1.18	0.87	1.18
	HRH034U2	95	22	17.4	1.18	0.87	1.18
	HRH036U2	95	22	18.4	1.18	0.87	1.18
	HRH038U2	115	23	18.8	0.98	0.73	0.98
	HRH040U2	115	25	19.8	0.98	0.73	0.98
	HRH041U2	120	25	16.8	0.68	0.67	0.67
	HRH044U2	120	26	17.5	0.68	0.67	0.67
	HRH047U2	115	27	22.4	0.83	0.61	0.83
	HRH048U2	115	27	23.0	0.83	0.61	0.83
	HRH049U2	120	26	18.1	0.68	0.67	0.67
	HRH050U2	115	30	23.3	0.83	0.61	0.83
	HRH051U2	121.5	27.5	20.5	0.59	0.59	0.59
	HRH054U2	123	27.5	20.5	0.59	0.59	0.59
	HRH056U2	120	27.5	21.1	0.61	0.60	0.60
	HLH061T2	170	30	24.9	0.48	0.48	0.46
	HLH068T2	160	35.6	25.7	0.45	0.45	0.45
HLJ072T2	180	35	30.0	0.42	0.42	0.42	
HLJ075T2	190	35	31.2	0.41	0.40	0.41	
HLJ083T2	190	39	34.0	0.36	0.36	0.37	
Motor voltage code 4 380-415 V / 3ph / 50 Hz 460 V / 3 ph / 60 Hz	HRH029U4	45	10	6.8	4.66	3.42	4.66
	HRH031U4	45	10	7.3	4.66	3.42	4.66
	HRH032U4	45	10	7.5	4.66	3.42	4.66
	HRH034U4	45	10	8.0	4.66	3.42	4.66
	HRH036U4	45	10	8.4	4.66	3.42	4.66
	HRH038U4	50	12	9.4	3.87	2.85	3.87
	HRH040U4	50	12	10.0	3.87	2.85	3.87
	HRH041U4	60	13	8.8	2.65	2.61	2.60
	HRH044U4	60	13.5	9.1	2.65	2.61	2.60
	HRH047U4	53	13	10.0	3.29	2.41	3.29
	HRH048U4	53	14	10.5	3.29	2.41	3.29
	HRH049U4	60	13.5	10.2	2.65	2.61	2.60
	HRH051U4	70	13	8.3	2.37	2.35	2.34
	HRH054U4	70	15	10.2	2.37	2.36	2.35
	HRH056U4	70	15	10.6	2.37	2.35	2.34
	HLH061T4	82	15	12.8	2.20	2.20	2.20
	HLH068T4	87	19	12.8	2.20	2.20	2.20
	HLJ072T4	87	19	13.4	2.20	2.20	2.20
	HLJ075T4	100	18	15.7	1.62	1.60	1.63
	HLJ083T4	100	19	15.7	1.48	1.44	1.47
HCJ091T4	125	25	19.0	0.98	0.97	1.01	
HCJ106T4	125	26	21.5	0.98	0.97	1.01	
HCJ121T4	125	27	24.0	0.98	0.97	1.01	

GENERAL INFORMATION

PRODUCT INFORMATION

SYSTEM DESIGN

INTEGRATION INTO SYSTEM

ORDERING INFORMATION

Three phase electrical characteristics

Compressor model		LRA	MCC	Max. operating current	Winding resistance (Ohm)		
		A	A	A	L2-L3	L1-L3	L2-L1
Motor voltage code 7 575 V / 3ph / 60 Hz	HRH032U7	38	8.5	6.2	7.34	5.38	7.34
	HRH034U7	38	8.5	6.6	7.34	5.38	7.34
	HRH036U7	38	8.5	7.0	7.34	5.38	7.34
	HRH038U7	40	9.5	6.7	6.09	4.47	6.09
	HRH040U7	40	10	6.7	6.09	4.47	6.09
	HRH041U7	42	10	6.6	4.47	4.40	4.39
	HRH049U7	42	10.5	7.4	4.47	4.40	4.39
	HRH051U7	53	11.5	7.8	4.12	4.06	4.03
	HRH054U7	53	11.7	8.2	4.12	4.06	4.03
	HRH056U7	53	12.5	8.5	4.12	4.06	4.03
	HLH061T7	63.6	12	10.8	2.89	2.83	2.87
	HLH068T7	62	13.5	10.4	3.26	3.29	3.33
HLJ072T7	62	15	11.0	3.26	3.29	3.33	
HLJ083T7	72	14.5	12.5	2.51	2.48	2.53	
Motor voltage code 9 380 V / 3ph / 60 Hz	HRH031U9	52	12.5	8.3	3.01	2.20	3.01
	HRH034U9	52	10	9.1	3.01	2.20	3.01
	HRH038U9	59.6	13.5	9.8	2.51	1.84	2.51
	HRH054U9	81	16	13.1	1.49	1.46	1.48
	HLH061T9	96	20	15.8	1.27	1.25	1.28
	HLH068T9	95	19	13.1	0.58	0.58	0.58
	HLJ072T9	95	19	17.5	0.58	0.58	0.58
	HLJ083T9	110	22.4	20.8	1.13	1.08	1.10

Single phase electrical characteristics

Compressor model		LRA	MCC	Max. operating current	Winding resistance (Ohm)	
		A	A	A	Start	Run
Motor voltage code 5 200-220 V / 1 ph / 50 Hz	HRM032T5	97	23	17.9	1.51	0.69
	HRM034T5	97	25	19.5	1.51	0.69
	HRM038U5	97	25	21.2	1.51	0.69
	HRM042T5	97	27	24.2	1.51	0.69
	HRM042U5	97	26	24.2	1.51	0.69
	HRM047T5	102.5	31.2	29.0	1.61	0.66
	HRM047U5	102.5	31.2	29.0	1.61	0.66
	HRM060U5	130	45	33.9	1.02	0.39
Motor voltage code 1 208-230 V / 1 ph / 60 Hz	HRM025T1	69	19	13.8	1.74	0.85
	HRM032U1	96.7	26	20.1	1.57	0.67
	HRM034U1	96.7	26	21.4	1.57	0.67
	HRM038U1	105	30	24.7	1.44	0.54
	HRM040U1	115	32.9	25.5	1.43	0.54
	HRM042U1	115	32.9	26.8	1.45	0.54
	HRM045U1	115	35	28.5	0.82	0.32
	HRM047U1	120	38	29.8	1.32	0.52
	HRM048U1	150	41.5	32.5	0.86	0.33
	HRM051U1	150	40	31.9	0.86	0.33
	HRM054U1	150	39	33.9	0.86	0.33
	HRM058T1	160	45	36.0	1.72	0.27
	HRM058U1	145	45	36.4	0.84	0.29
	HRM060T1	160	45	37.2	1.76	0.28
	HRM060U1	145	45	37.7	0.84	0.29
	HLM068T1	145	45	38.2	0.84	0.29
HLM072T1	145	45	40.5	0.84	0.29	
HLM081T1	145	45	41.2	0.84	0.29	

Electrical data, connections and wiring

Single phase electrical characteristics

Compressor model		LRA	MCC	Max. operating current	Winding resistance (Ohm)	
		A	A	A	Start	Run
Motor voltage code 5 200-220 V / 1 ph / 50 Hz	HRP032T5	97	23	18.3	1.51	0.69
	HRP034T5	97	25	19.5	1.51	0.69
	HRP038T5	97	25	21.2	1.51	0.69
	HRP040T5	97	25	22.3	1.51	0.69
	HRP042T5	97	27	24.2	1.51	0.69
	HRP045T5	102.5	30	27.9	1.61	0.66
	HRP047T5	102.5	31.2	29.0	1.61	0.66
	HRP054T5	130	40	30.8	1.02	0.39
	HRP058T5	130	42	32.8	1.02	0.39
	HRP060T5	130	40	33.9	1.02	0.39
	HLP068T5	130	40	38.4	1.02	0.39
	HLP072T5	130	40	38.9	1.02	0.39
HLP081T5	130	47	45.8	1.02	0.39	
Motor voltage code 1 208-230 V / 1 ph / 60 Hz	HRP025T1	69	19	13.8	1.74	0.85
	HRP034T1	96.7	24.5	21.4	1.57	0.67
	HRP042T1	115	32.9	26.8	1.47	0.55
	HRP051T1	150	40	31.9	0.86	0.33
	HRP060T1	160	45	37.2	1.76	0.28
	HLP068T1	145	45	38.2	0.84	0.29
	HLP072T1	145	45	40.5	0.84	0.29
	HLP081T1	145	45	41.2	0.84	0.29
Motor voltage code 5 200-220 V / 1 ph / 50 Hz	HRH029U5	97	24	17.9	1.51	0.69
	HRH031U5	97	25	19.2	1.51	0.69
	HRH032U5	97	25	19.8	1.51	0.69
	HRH034U5	97	25.5	21.0	1.51	0.69
	HRH036U5	97	25.5	22.3	1.51	0.69
	HRH038U5	102.5	28	23.8	1.61	0.66
	HRH040U5	102.5	33	26.6	1.61	0.66
	HRH051U5	130	38	31.7	1.02	0.39
	HRH054U5	130	40	38.2	1.02	0.39
	HRH056U5	130	40	38.9	1.02	0.39
	HLH061T5	130	42	44.1	1.02	0.39
	HLH068T5	130	45	41.7	1.02	0.39
	HLJ072T5	130	45	48.9	1.02	0.39
	HLJ083T5	130	50	55.7	1.02	0.39
Motor voltage code 1 208-230 V / 1 ph / 60 Hz	HRH029U1	96.7	27	19.5	1.45	0.72
	HRH031U1	96.7	26.5	20.8	1.57	0.67
	HRH032U1	87.5	26	17.9	1.66	0.67
	HRH034U1	115	31	20.9	1.40	0.53
	HRH036U1	105	34	23.3	1.22	0.54
	HRH038U1	115	33	23.6	1.21	0.54
	HRH039U1	115	31	22.8	1.19	0.53
	HRH040U1	115	32	27.7	1.31	0.53
	HRH041U1	150	36.9	28.2	0.86	0.33
	HRH044U1	150	38	29.9	0.86	0.33
	HRH047U1	135	43	35.3	1.06	0.43
	HRH048U1	135	42	35.6	1.06	0.43
	HRH049U1	150	45	32.4	0.84	0.32
	HRH050U1	135	43	39.3	1.06	0.43
	HRH051U1	150	41	33.6	0.84	0.32
	HRH054U1	145	45	34.1	0.84	0.29
	HRH056U1	145	47	35.9	0.84	0.29
	HLH061T1	145	42	41.8	0.84	0.29
	HLH068T1	145	42	46.1	0.84	0.29
	HLJ072T1	145	42	48.6	0.84	0.29
HLJ083T1	145	42	57.6	0.84	0.29	

GENERAL INFORMATION

PRODUCT INFORMATION

SYSTEM DESIGN

INTEGRATION INTO SYSTEM

ORDERING INFORMATION

Electrical data, connections and wiring

IP rating

The compressor terminal box IP rating according to IEC 529 is **IP22** for all models. IP ratings is only valid when correctly sized cable glands of the IP rating is applied.

- First numeral, level of protection against contact and foreign objects
2 protection against object size over 12.5 mm (fingers of similar)
- Second numeral, level of protection against water
2 protection against dripping water when tilted up to 15°

LRA (Locked Rotor Amp)

Locked Rotor Amp value is the higher average current as measured on mechanically blocked compressors tested under nominal voltage. The LRA value can be used as a rough estimation for

the starting current. However, in most cases, the real starting current will be lower.

MCC (Maximum Continuous Current)

The MCC is the current at which the motor protection trips under maximum load and low voltage conditions. This MCC value is the maximum at which the compressor can be

operated in transient conditions and out of the application envelope. Above this value, the external electronic module will cut-out the compressor to protect the motor.

Max Oper. A (Max operating current)

The max. operating current is the current when the compressors operate at maximum load conditions and 10% below nominal voltage. Max Oper. A can be used to select cables and contactors. In normal operation, the compressor

current consumption is always less than the Max Oper. A value. When using the Max Operating Current to define cables and contactors, a tolerance of +5% need to be taken into account.

Winding resistance

Winding resistance is the resistance between indicated terminal pins at 25°C (resistance value +/- 7%).

Winding resistance is generally low and it requires adapted tools for precise measurement. Use a digital ohm-meter, a '4 wires' method and measure under stabilised ambient temperature. Winding resistance varies strongly with winding temperature ; If the compressor is stabilised at a different value than 25°C, the measured resistance must be corrected with following formula:

$$R_{t_{amb}} = R_{25^{\circ}\text{C}} \frac{a + t_{amb}}{a + t_{25^{\circ}\text{C}}}$$

$t_{25^{\circ}\text{C}}$: reference temperature = 25°C

t_{amb} : temperature during measurement (°C)

$R_{25^{\circ}\text{C}}$: winding resistance at 25°C

R_{amb} : winding resistance at t_{amb}

coefficient a= 234.5

Motor protection

Danfoss Scroll Compressors H-Series are equipped with an internal line break protector mounted on the motor windings. The protector is an automatic reset device, containing a snap action bimetal switch.

Internal protectors respond to over-current and overheating. They are designed to interrupt

motor current under a variety of fault conditions, such as lose phase, running overload, and locked rotor.

If the internal overload protector trips out, it must cool down to about 60°C to reset. Depending on ambient temperature, this may take up to several hours.

Phase sequence and reverse rotation protection

The compressor will only operate properly in a single direction. Use a phase meter to establish the phase orders and connect line phases L1, L2 and L3 to terminals T1, T2 and T3, respectively. For three-phase compressors, the motor will run equally well in both directions. Reverse rotation results in excessive noise; no pressure differential between suction and discharge; and suction line warming rather than immediate cooling. A service technician should be present at initial start-up to verify that supply power is properly phased and that compressor and auxiliaries are

rotating in the correct direction.

Danfoss HR* and HL* series scroll compressor are designed to operate for a maximum of 150 hours in reverse, but as a reverse rotation situation can go unnoticed for longer periods, phase monitors are recommended.

For HC* series compressors, phase monitors are required. The selected phase monitor should lock out the compressor from operation in reverse.

Electrical data, connections and wiring

Electrical connections

Danfoss scroll compressors are designed to operate without any assistance if running within

the defined nominal voltage. PSC wiring is sufficient (see below).

PSC wiring

The start winding (C-S) of the motor remains in circuit through a permanent (run) capacitor.

This permanent (run) capacitor is connected between the start winding (C-S) and the run winding (C-R).

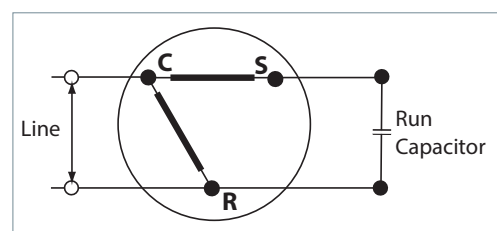

CSR wiring

If start assist is required, in case of operating below the nominal voltage, a CSR starting device is required.

During start-up, the start winding (C-S) is energised through an electromagnetic potential relay and a start capacitor.

A permanent (run) capacitor is wired between the start winding (C-S) and the run winding (C-R).

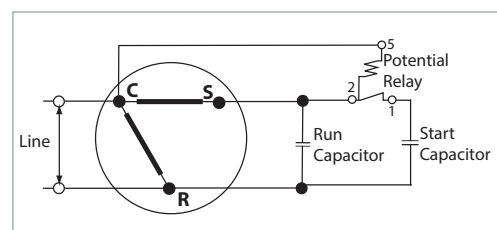

Nominal capacitor value and relays

		Models	PSC wiring Run capacitor	CSR wiring Start capacitor	Relay	
50 Hz, motor voltage code 5	R22	HRM025-032-034-038-040-042	70 μ F	145-175 μ F	3ARR3*3AL*	RVA 9CKL
		HRM045-047	60 μ F	145-175 μ F	3ARR3*3AL*	RVA 9CKL
		HRM054	55 μ F	161-193 μ F	3ARR3*24AP*	RVA 3EKL
		HRM058-060	55 μ F	88-108 μ F	3ARR3*25AS*	RVA 4GKL
		HLM068-072-075-081	55 μ F	88-108 μ F	3ARR3*25AS*	RVA 4GKL
	R407C	HRP025-034-038-040-042	70 μ F	145-175 μ F	3ARR3*3AL*	RVA 9CKL
		HRP045-047	60 μ F	145-175 μ F	3ARR3*3AL*	RVA 9CKL
		HRP054	55 μ F	161-193 μ F	3ARR3*24AP*	RVA 3EKL
		HRP058-060	55 μ F	88-108 μ F	3ARR3*25AS*	RVA 4GKL
		HLP068-072-075-081	55 μ F	88-108 μ F	3ARR3*25AS*	RVA 4GKL
	R410A	HRH029-031-032-034-036	70 μ F	145-175 μ F	3ARR3*3AL*	RVA 9CKL
		HRH038-040	60 μ F	145-175 μ F	3ARR3*3AL*	RVA 9CKL
		HRH051-054-056	55 μ F	88-108 μ F	3ARR3*25AS*	RVA 4GKL
		HLH061-068, HLJ072-083	55 μ F	88-108 μ F	3ARR3*25AS*	RVA 4GKL
	60 Hz, motor voltage code 1	R22	HRM025-032-034	45 μ F	145-175 μ F	3ARR3*3M*
HRM038			55 μ F	88-108 μ F	3ARR3*3L*	RVA 2ABKL
HRM040-042-045-047			60 μ F	88-108 μ F	3ARR3*3L*	RVA 2ABKL
HRM048			60 μ F	161-193 μ F	3ARR3*3L*	RVA 2ABKL
HRM051-054			70 μ F	161-193 μ F	3ARR3*3L*	RVA 2ABKL
HRM058T1-060T1, HLM068-072-075-081			80 μ F	189-227 μ F	3ARR3*25S*	RVA A4IKL
R407C		HRP051	70 μ F	161-193 μ F	3ARR3*3L*	RVA 2ABKL
		HLP068-072-075-081	80 μ F	189-227 μ F	3ARR3*3L*	RVA 2ABKL
R410A		HRH031	45 μ F	145-175 μ F	3ARR3*3M*	RVA 2ACKL
		HRH032-034	50 μ F	88-108 μ F	3ARR3*3L*	RVA 2ABKL
		HRH036	55 μ F	88-108 μ F	3ARR3*3AL*	RVA 9CKL
		HRH038-039-040	60 μ F	88-108 μ F	3ARR3*3L*	RVA 2ABKL
		HRH041-044-048-049-050-051	70 μ F	161-193 μ F	3ARR3*3L*	RVA 2ABKL
		HRH054-056, HLH061-068, HLJ072-083	80 μ F	189-227 μ F	3ARR3*3L*	RVA 2ABKL

Approvals and certifications

Approvals and certificates Danfoss scroll H-series compressors comply with the following approvals and certificates. Certificates are listed on the product datasheets: <http://www.danfoss.com/odsg>

CE (European Directive)		All models
UL (Underwriters Laboratories)		All models
Other approvals / certificates		Contact Danfoss

Pressure equipment directive 2014/68/EU

Products	All models
Refrigerating fluids	Group 2
Category PED	I
Evaluation module	no scope

Low voltage directive 2014/35/EU

Products	All models
Declaration of conformity ref. Low voltage Directive 2014/35/EU	Contact Danfoss

Machines directive 2006/42/EC

Products	All models
Manufacturer's declaration of incorporation ref. Machines Directives 2006/42/EC	Contact Danfoss

Internal free volume

Products	Internal free volume at LP side without oil (litre)	Internal free volume at HP side without oil (litre)
HRM/P032-034-038-040-042 HRH029-031-032-034-036-038	2.93	0.49
HRM/P045-047 HRH040	3.20	0.70
HRM/P048-051-054-058-060, HLM/P068-072-075-081 HRH044-049-051-054-056, HLH/J061-068-072-075-083	3.44	0.71
HCM/P094-109-120	5.92	0.51
HCJ091-106-121	5.75	0.51

GENERAL INFORMATION

PRODUCT INFORMATION

SYSTEM DESIGN

INTEGRATION INTO SYSTEM

ORDERING INFORMATION

Operating conditions

Refrigerant and lubricants

General information

When choosing a refrigerant, different aspects must be taken into consideration:

- Legislation (now and in the future)
- Safety
- Application envelope in relation to expected running conditions
- Compressor capacity and efficiency
- Compressor manufacturer recommendations & guidelines

Additional points could influence the final choice:

- Environmental considerations
- Standardisation of refrigerants and lubricants
- Refrigerant cost
- Refrigerant availability

PVE

Polyvinyl ether (PVE) is an innovative refrigeration lubricant for HFC refrigerant systems. PVE is as hygroscopic as existing polyolester lubricants (POE), but PVE doesn't chemically react with water; no acids are formed and compressor evacuation is easier.

The compressor technology applied in Danfoss H-series scroll compressors in combination with PVE lubricant provides the best possible result in terms of reliability and compressor lifetime. The PVE lubricant is compatible with R22 which makes the Danfoss H-series scroll compressors a very versatile multi- refrigerant solution.

Alkylbenzene oil

Alkylbenzene oil can be applied in systems using HCFC refrigerants (R22). Compared to a mineral oil it provides distinct advantages: excellent miscibility, excellent thermal stability, compatibility with mineral oils and constant quality.

Danfoss Scroll H_M series compressors are charged with Alkylbenzene oil and herewith offer an economically interesting alternative to the Danfoss H series in regions where R22 is still the predominant refrigerant. Note however that Danfoss H-series scroll compressors can not be used with HFC refrigerants.

Oil type

Danfoss scroll compressors are charged with oil at the factory with the oils indicated, in the following table.

Compressor range	Oil type
HRM / HLM / HCM	Alkylbenzene
HRP / HLP / HCP	PVE
HRH / HLH	PVE
HLJ/HCJ	PVE

Effective week 31 of 2009, the HRP/HLP/ HCP & HRH/HLH series of compressors were changed from POE oil to PVE oil. Compressors produced prior to this week still had POE, and may be in stock in the warehouses until supply is exhausted. This change was made to standardize to the better oil for reliability. Replacement PVE 320HV is available for topping up or replacing oil in the field (see accessory section). As it is fully miscible with POE, Danfoss recommends the 320HV regardless of original oil charge in the compressor.

Residual moisture

Prior to shipment from the factory, every compressor is dehydrated, evacuated, and charged with dry nitrogen. Maximum residual

moisture levels are 0.0082 oz. for models capacities up to HRM/HRP047 and HRH040 and 0.0120 oz. for larger compressors.

Run-in process

Our H product ranges feature a compliance technology which allows

- an exceptional slugging capability (radial compliance)
- a very low starting torque (axial compliance)

When a compressor with compliance technology is new, the performance is not immediately at peak. A run-in period is needed to polish all surfaces as well as to reduce friction and leakage. The run-in period eliminates extra power input

General requirements

Proper piping practices should be employed to:

1. Ensure adequate oil return, even under minimum load conditions (refrigerant speed, piping slope). For validation tests see section "Manage oil in the circuit".

2. Avoid condensed liquid refrigerant from draining back to the compressor when stopped (discharge piping upper loop). For validation tests see section "Manage off cycle migration".

General recommendations are described in the figures below:

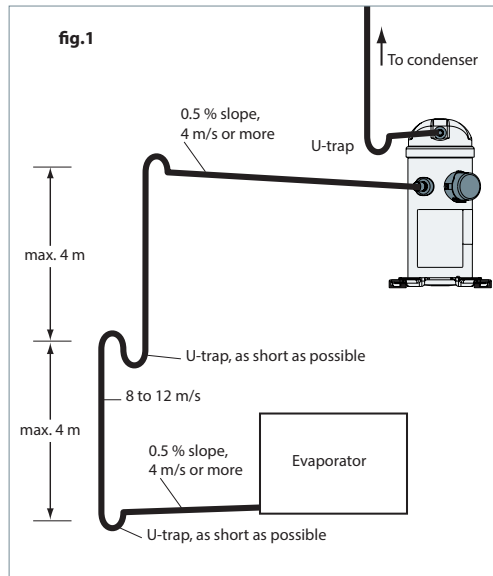

3. Piping should be designed with adequate three-dimensional flexibility to avoid excess vibration. It should not be in contact with the surrounding structure, unless a proper tubing

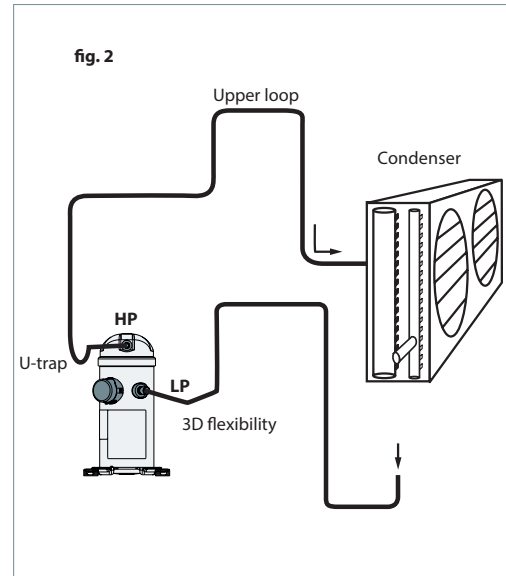

mount has been installed. For more information on noise and vibration, see section on: "Manage sound and vibration".

GENERAL INFORMATION
PRODUCT INFORMATION
SYSTEM DESIGN
INTEGRATION INTO SYSTEM
ORDERING INFORMATION

Design piping

Tandem requirements

Danfoss scroll compressor H series tandem use static oil balancing principle to equalize oil level between the compressors by gravity. This is ensured by a precise suction and oil equalization piping designs.

The discharge line as no impact on oil balancing and is shown with tees, to indicate that both left and right side discharge header are possible

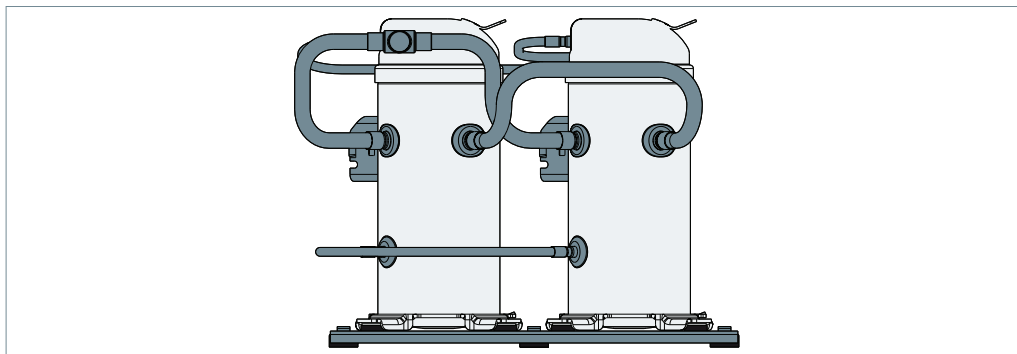

Danfoss scroll H series compressors in C8 version can be mounted in tandem assemblies.

Such manifolding applications require special design considerations that go beyond the scope of this document. Please contact Danfoss for further information.

By default, H series tandems are not factory-built, just provide tandem version compressors (feature 8).

For each tandem configuration, specific outline drawings are available as indicated in following tables.

R Suction and oil & gas equalization piping drawing must be respected (diameters, minimum straight lengths)

Tandem model	Comp.1	Comp.2	Connection Sizes		Oil equalization (in)	Gas equalization (in)	Kit tandem Code No	Outline drawing number
			Suction (in)	Discharge (in)				
TLJ082	HRH041	HRH041	1-1/8"	3/4"	1/2"	7/8"	120Z0636	8556080
TLJ098	HRH049	HRH049	1-1/8"	3/4"	1/2"	7/8"	120Z0636	8556080
TLJ122	HLH061	HLH061	1-1/8"	3/4"	1/2"	7/8"	120Z0636	8556080
TLJ136	HLH068	HLH068	1-1/8"	3/4"	1/2"	7/8"	120Z0636	8556080
TLJ144	HLJ072	HLJ072	1-1/8"	3/4"	1/2"	7/8"	120Z0636	8556080
TLJ166	HLJ083	HLJ083	1-1/8"	3/4"	1/2"	7/8"	120Z0636	8556080
TCJ181	HCJ091	HCJ091	1-5/8"	1-1/8"	1/2"	1-1/8"	120Z0636	8556153
TCJ211	HCJ106	HCJ106	1-5/8"	1-1/8"	1/2"	1-1/8"	120Z0636	8556153
TCJ241	HCJ121	HCJ121	1-5/8"	1-1/8"	1/2"	1-1/8"	120Z0636	8556153

Design compressor mounting

General requirements

Compressors used in single applications must be mounted with flexible grommets.

and the manifold assembly must be mounted with flexible grommets onto frame.

Compressors used in parallel application must be mounted with rigid mounting spacers onto rails

During operation, the maximum inclination from the vertical plane must not exceed 3 degrees.

Single requirements

H-series compressors come delivered with flexible grommets, accessory Mounting kit 120Z5064.

The grommets must be compressed until contact between the flat washer and the steel mounting sleeve is established. The required bolt size for the H-series compressors is M8*40mm. This bolt must be tightened to a torque of 11 Nm.

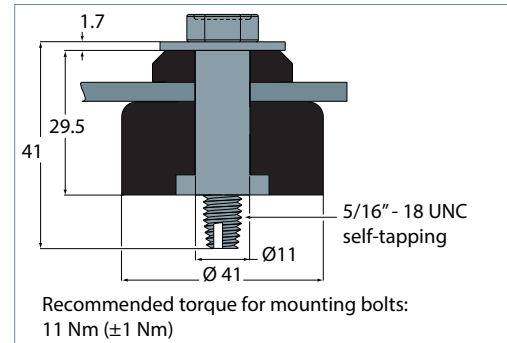

Tandem requirements

Parallel mounting feet

For parallel mounting, the compressor must be mounted with rigid mounting spacers (included in the tandem kit 120Z0636) on the rails.

Rubber grommets and sleeves (delivered with the compressor) must be installed below the rails.

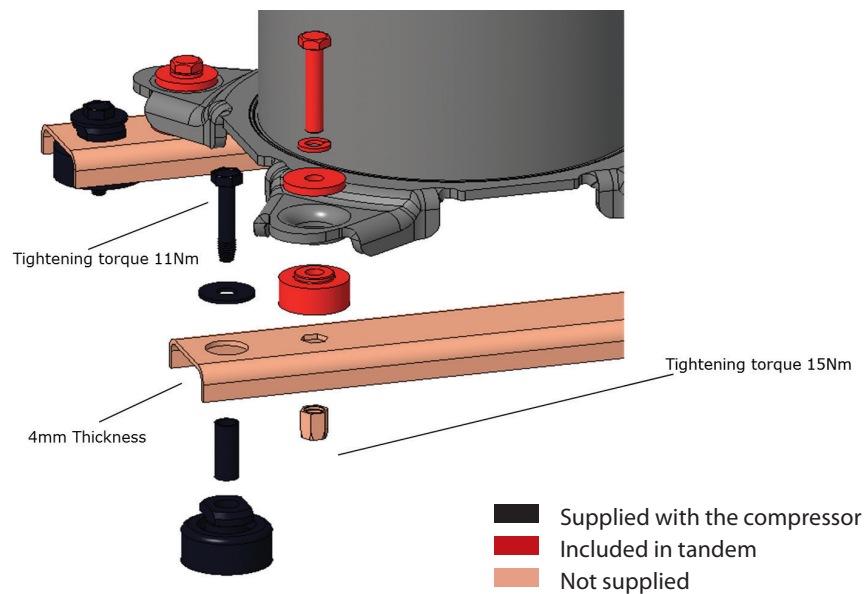

GENERAL INFORMATION

PRODUCT INFORMATION

SYSTEM DESIGN

INTEGRATION INTO SYSTEM

ORDERING INFORMATION

Compressor sound radiation

Typical sounds and vibrations in systems can be broken down into the following three categories:

- Sound radiation (through air)
- Mechanical vibrations (through parts and structure)
- Gas pulsation (through refrigerant)

The following sections focus on the causes and methods of mitigation for each of the above sources.

For sound radiating from the compressors, the emission path is air and the sound waves are travelling directly from the machine in all directions.

Sound levels are as follows:

- For compressors running alone:

Compressor model	50 Hz		60 Hz		Acoustic hood code number
	Sound power dB(A)	Attenuation dBA ①	Sound power dB(A)	Attenuation dBA ①	
HRM025-038	66	5	69	5	120Z5083
HRM040-047	67	5	70	5	120Z5083
HRM048-054	68	5	71	5	120Z5084
HRM058-060	69	5	72	5	120Z5084
HLM068-081	70	5	73	5	120Z5084
HCM094	71	5	74	5	120Z5085
HCM109-120	74	5	78	5	120Z5085
HRH029-032	65	5	68	5	120Z5083
HRH034-040	66	5	69	5	120Z5083
HRH041-054	67	5	70	5	120Z5084
HLH061	70	5	73	5	120Z5084
HLH068-HLJ083	71	5	74	5	120Z5084
HCJ091-106-121	73	5	76	5	120Z5085

① Attenuation given with acoustic hood only
 Acoustic hood could be applied for both single and tandem version compressors.
 Materials are UL approved and RoHS compliant
 Sound power and attenuation are given at ARI conditions, measured in free space
 H*P series same as H*M series. Compressor's noise test is after compressor run-in 72hrs. Maximum sound is +5dBA

Note: During compressor shut down, a short reverse rotation sound is generated. The duration of this sound depends on the pressure difference at shut down and should be less than 3 seconds. This phenomenon has no impact on compressor reliability.

Mitigations methods:
 We can consider two means to reduce compressors sound radiations:

1. Acoustic hoods are quick and easy to install and do not increase the overall size of the compressors to a great extent. Acoustic hoods are available from Danfoss as accessories. Refer to the table above for sound levels, attenuation and code numbers.
2. Use of sound-insulation materials on the inside of unit panels is also an effective means to reduce radiation.

GENERAL INFORMATION
PRODUCT INFORMATION
SYSTEM DESIGN
INTEGRATION INTO SYSTEM
ORDERING INFORMATION

Mechanical vibrations

Vibration isolation constitutes the primary method for controlling structural vibration. H-series scroll compressors are designed to produce minimal vibration during operations. The use of rubber isolators on the compressor base plate or on the frame of a manifolded unit is very effective in reducing vibration being transmitted from the compressor(s) to the unit. Rubber grommets are supplied with all H-series scroll compressors.

Once the supplied rubber grommets have been properly mounted, vibration transmitted from the compressor base plate to the unit

are held to a strict minimum. In addition, it is extremely important that the frame supporting the mounted compressor be of sufficient mass and stiffness to help dampen any residual vibration potentially transmitted to the frame. The tubing should be designed so as to both reduce the transmission of vibrations to other structures and withstand vibration without incurring any damage. Tubing should also be designed for three-dimensional flexibility. For more information on piping design, please see the section entitled "Essential piping design considerations".

Gas pulsation

The Danfoss Scroll Compressors H-series has been designed and tested to ensure that gas pulsation has been optimised for the most commonly encountered air conditioning pressure ratio. Manifolded compressors are equivalents to lagged sources of gas pulsation. Therefore pulse level can vary during time.

Mitigations methods:
If an unacceptable level is identified, a discharge muffler with the appropriate resonant volume and mass can be installed.

Manage operating envelope

Requirement

R The operating envelope for H-series scroll compressors is given in the figures below and guarantees reliable operations of the compressor for steady-state and transient operation.

Steady-state operation envelope is valid for a suction superheat within 5K to 30K range.

R22, R407C Model variation T

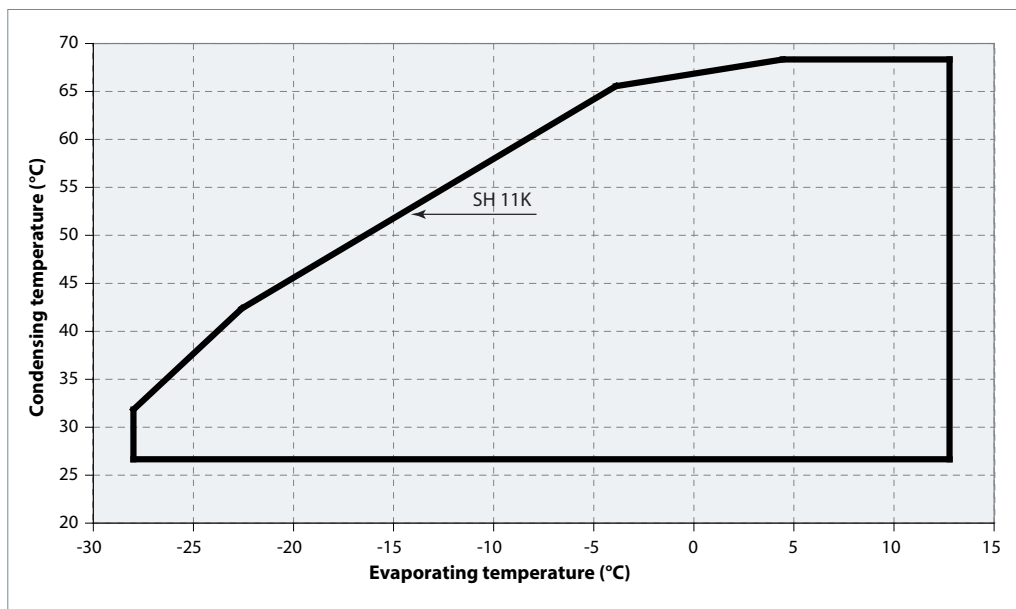

R410A Model variation T

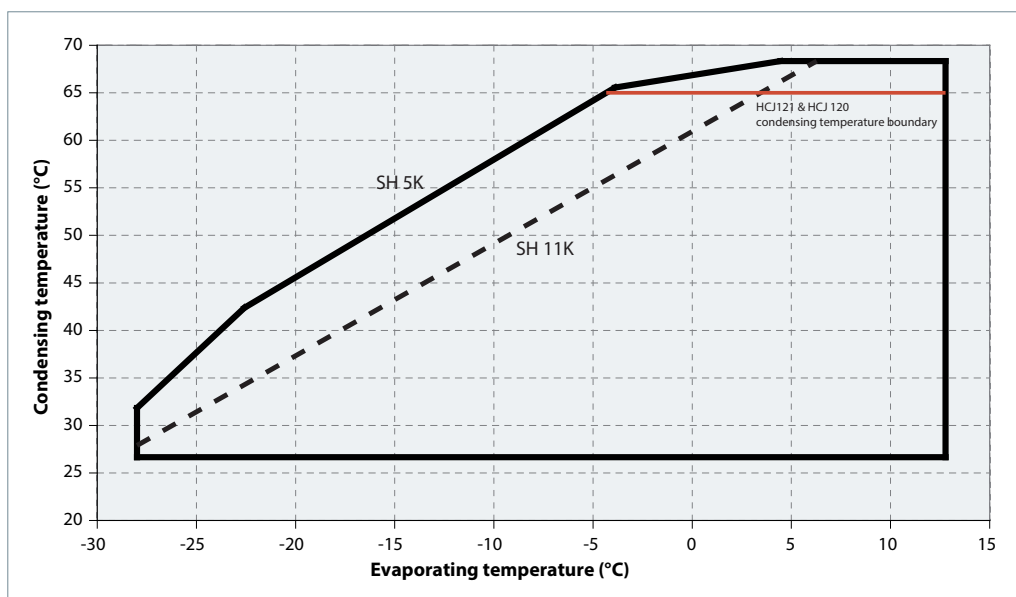

R22, R410A
Model variation U

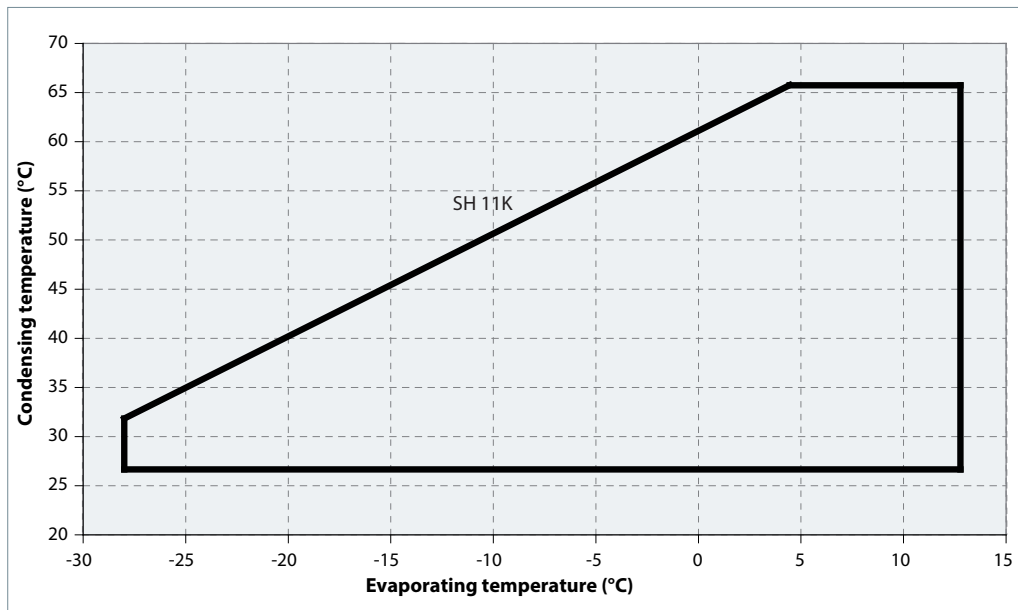

		R22	R407C	R410A
Working pressure range high side	bar (g)	10.9 - 27.7	10.5 - 29.1	15.8 - 44.5
Working pressure range low side	bar (g)	1.4 - 6.9	1.1 - 6.4	1.9 - 10.8
Maximum high pressure safety switch setting*	bar (g)	29	30	45
Minimum low pressure safety switch setting	bar (g)	0.5	0.5	1.5
Recommended pump-down switch settings	bar (g)	1.5 bar below nominal evap. pressure with minimum limitation as below		
Minimum low pressure pump-down switch setting	bar (g)	1.5	1.3	2.3

* Maximum allowable pressure on high pressure side according to PED regulation.

High and low pressure protection

R LP and HP safety switches must never be bypassed nor delayed and must stop all the compressors.

When caused low by LP safety switch, limit the number of auto-restart to maximum 5 times within 12 hours.

! HP safety switch must be manual reset

Depending on application operating envelope, you must define HP and LP limits within operating envelope and pressure setting table above.

For H-series compressors, the external Discharge Gas Temperature protection (DGT) is required if the high and low pressure switch settings do not protect the compressor against operations beyond its specific application envelope.

The discharge gas thermostat accessory kit (code 7750009) includes all components required for installation as shown on the right. DGT installation must respect below requirements:

- The thermostat must be attached to the discharge line within 150 mm from the compressor discharge port and must be thermally insulated and tightly fixed on the pipe.
- The DGT should be set to open at a discharge gas temperature of 135°C.

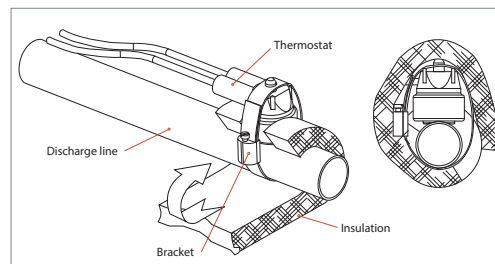

Manage operating envelope

System evaluation

HP and LP must be monitored to respect operating envelope limitations. We consider two types of operating envelope management:

<p>Basic:</p> <ul style="list-style-type: none"> • HP and LP switch • MOP (Max Operating Pressure) ensured by expansion device • Condensing pressure control • DGT external 	<p>Advanced:</p> <ul style="list-style-type: none"> • HP and LP sensor • Operating envelope limits (permanent and transient) integrated into control logic • DGT external
<p>See "Test, criteria and solutions"</p> <p>The diagram illustrates the operating envelope for a compressor. It features a central 'Continuous Running Area' enclosed by a red boundary. The top boundary is labeled 'HP switch setting', the left boundary is 'LP switch setting', and the bottom boundary is 'Condensing pressure control'. A diagonal line labeled 'DGT' (Direct Gas Temperature) runs from the top-left towards the center. A vertical line on the right is labeled 'MOP + test N°3'. The bottom-right corner is labeled 'tests N°1 and 2'.</p>	

Test, criteria and solutions

Test N°	Purpose	Test condition	Pass criteria	Solutions
1	Check the compressor operation in the "continuous running area".	Start test at minimum foreseeable evaporating temperature (minimum ambient temperature)	Confirmed compressor stable working in the continuous running area.	Work on compressor staging, fan staging, water flow etc.
2		Perform a defrost test if reversible unit		

GENERAL INFORMATION

PRODUCT INFORMATION

SYSTEM DESIGN

INTEGRATION INTO SYSTEM

ORDERING INFORMATION

Manage superheat

During normal operation, refrigerant enters the compressor as a superheated vapor. Liquid flood back occurs when a part of the refrigerant entering the compressor is still in liquid state.

Liquid flood back can cause oil dilution and, in extreme situations lead to liquid slugging that can damage compression parts.

Requirement

In steady state conditions,
 • Suction superheat must remain within 5K to 30K
 • According to the floodback chart

In transient conditions,
 • According to the floodback chart

Discharge temperature sensor must be placed onto the discharge fitting and be insulated.

Oil temperature sensor must be placed on the mid shell, closed to the lower shell, and be insulated.

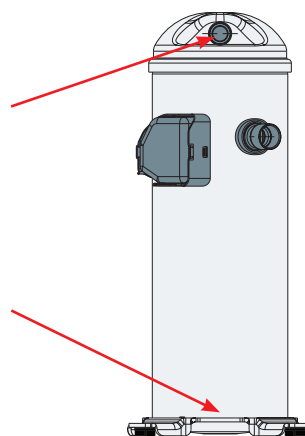

System evaluation

Use the tables below in relation with the system charge and the application to quickly evaluate the risk and potential tests to perform.

	BELOW CHARGE LIMIT	ABOVE CHARGE LIMIT
Non reversible	No test or additional safeties required	Liquid flood back test
Reversible	Defrost test	Liquid flood back test Defrost test

Charge limit is defined in table below:

	Models	Refrigerant charge limit (kg)
Single	HRM032-034-038-040-042-045-047 HRP034-038-040-042-045-047 HRH029-031-032-034-036-038-039-040-047-048	3.6
	HRM048-051-054-058-060/HLM068-072-075-078-081 HRP048-051-054-058-060/HLP068-072-075-078-081 HRH041-044-049-051-054-056/ HLH061-068-HLJ072-075-083	5.4
	HCM094-109-120 HCP094-109-120 HCJ091-106-121	7.2
Tandem	TLJ082-098-122-136-144-166	6
	TCJ181-211-241	8

Manage superheat

Test, criteria and solutions

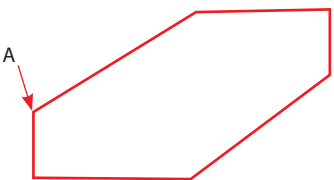
Test N°	Purpose	Test condition	Pass criteria	Solutions
Liquid flood back test	Steady-state	<p>Liquid flood back testing must be carried out under expansion valve threshold operating conditions: a high pressure ratio and minimum evaporator load (A).</p> 	Suction superheat >5K(9°F)	<ol style="list-style-type: none"> 1. Check expansion valve selection and setting. 2. Add a suction accumulator*.
	Transient	<p>Tests must be carried out with most unfavorable conditions :</p> <ul style="list-style-type: none"> • fan staging, • compressor staging • ... 	Refer to flood back chart criteria	<ol style="list-style-type: none"> 1. Check expansion valve selection and setting. <ul style="list-style-type: none"> -For Thermostatic expansion valve (TXV) check bulb position... -For Electronic expansion valve (EXV) check measurement chain and PID.... 2. Add a suction accumulator*.
Defrost test	Check liquid floodback during defrost cycle	Defrost test must be carried out in the most unfavorable condition (at 0°C evaporating temperature).	Refer to flood back chart criteria	In reversible systems, the defrost logic can be worked out to limit liquid floodback effect. (for more details see "Control Logic").

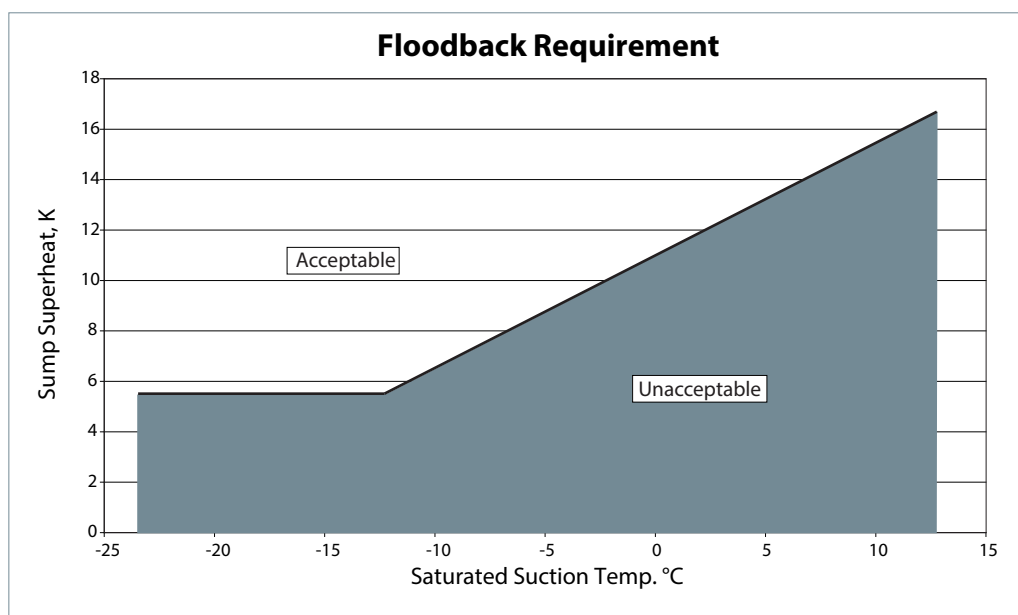

*Suction accumulator offers protection by trapping the liquid refrigerant upstream from the compressor. The accumulator should be sized at least 50 % of the total system charge. Suction accumulator dimensions can impact oil return (gas velocity, oil return hole size...), therefore oil return has to be checked according to section "Manage oil in the circuit".

Manage off cycle migration

- R** Off -cycle refrigerant migration happens:
- when the compressor is located at the coldest part of the installation, refrigerant vapor condenses in the compressor.
 - or directly in liquid-phase by gravity or pressure difference.

When the compressor restarts, the refrigerant diluted in the oil, or stored in evaporator, generates poor lubrication conditions and may reduce bearings life time. In extreme situations, this leads to liquid slugging that can damage compression scrollset.

Requirement

- Compressor can tolerate occasional flooded start, but it should remain exceptional situation and unit design must prevent that this situation happen at each start
- Right after start, liquid refrigerant must not flow massively to compressor
- The charge limit is a threshold beyond some protective measures must be taken to limit risk of liquid slugging and extreme dilution at start. (refer to charge limit table in section "Manage superheat").

Evaluate the risk

Use the table below in relation with the system charge (refer to charge limit table in section "Manage superheat") and the application to

quickly define necessary safeties to implement and test to perform:

	BELOW CHARGE LIMIT	ABOVE CHARGE LIMIT
Non split	No test or additional safeties required	<ul style="list-style-type: none"> • Crankcase Heater* • Migration test • External Non Return Valve
Split	Since each installation is unique, no test can fully evaluate off-cycle migration, therefore the following safeties are required: <ul style="list-style-type: none"> • Crankcase Heater * • Liquid Line Solenoid Valve**+ pump-down cycle*** • (Internal Non-Return Valve integrated) 	

Manage off cycle migration

Test, criteria and solutions

Test N°	Purpose	Test condition	Pass criteria	Solutions
Migration test	Check that there is no migration of refrigerant into the compressor (either liquid or vapour condensating)	Energize CCH*. Stabilize the non-running system at a pressure equivalent to 5°C. Raise the system pressure equivalent to 20°C. When saturated condensing temperature reaches 20°C then start the unit.	When all compressors are idle: <ul style="list-style-type: none"> • Check in liquid line sight glass that there is no liquid refrigerant transfer • Refer to flood back chart criteria After compressors has started: <ul style="list-style-type: none"> • Oil superheat must remain the criteria refer to flood back chart. 	<ol style="list-style-type: none"> 1. Check bulb position, tightness of expansion device, 2. add LLSV** 3. add pump down cycle*** 4. Check Crank Case Heater efficiency

Oil temperature sensor must be placed between oil sight glass and compressor baseplate and be insulated.

* Crank case heater (CCH)

The Crank case heaters are designed to protect the compressor against off-cycle migration of refrigerant.

Additional heater power or thermal insulation might be needed in case of ambient temperature below -5°C and a wind speed above 5m/second. The heater must be energized whenever all the compressors are off.

Crank case heater accessories are available from Danfoss (see section "Accessories").

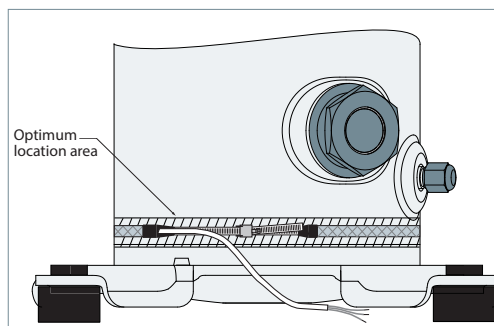

! Provide separate electrical supply for the heaters so that they remain energized even when the machine is out of service (e.g. seasonal shutdown).

It's recommended that the heater be turned on for a minimum of 8 hours prior to starting the compressor.

**Liquid line solenoid valve (LLSV)

A LLSV is used to isolate the liquid charge on the condenser side, thereby preventing against charge transfer to the compressor during off -cycles. The quantity of refrigerant on the low-pressure side of the system can be further reduced by using a pump-down cycle in association with the LLSV.

***Pump-down cycle

By decreasing pressure in the sump, pump down:

- evacuates refrigerant from oil
- set the sump saturating pressure much lower than ambience temperature and due to that, avoid refrigerant condensation in the compressor.

For more details on pump-down cycle see section "Control Logic".

On/off cycling (cycle rate limit)

Danfoss recommends a restart delay timer to limit compressor cycling. The timer prevents reverse compressor rotation, which may occur during brief power interruptions.

The system must be designed in a way that guarantees a minimum compressor running time of 2 minutes so as to provide for sufficient

motor cooling after start-up along with proper oil return. Note that the oil return may vary since it depends upon system design.

There must be no more than 12 starts per hour, a number higher than 12 reduces the service life of the motor-compressor unit. A three-minute (180-sec) time out is recommended.

Provide power supply and electrical protection

Wiring information

Requirements:

- An additional external overload protection is still advisable for either alarm or manual reset. For overload setting, take the max current you can face on the application and add 10%. Setting must always be lower than Max Operating Current (see table "Three phase electrical characteristics" from the section "Electrical data, connections and wiring")

- HP safety switch and DGT must be wired in the safety chain. Other safety devices such as LP can be either hardware or software managed.
- Provide separate electrical supply for the heaters so that they remain energized even when the machine is out of service (e.g. seasonal shutdown).

The wiring diagrams below are examples for a safe and reliable compressor wiring:

Control device.....	TH
Optional short cycle timer (3 min)	180 s
Control relay	KA
Liquid Line Solenoid valve.....	LLSV
Compressor contactor.....	KM
Phase monitor	PM
Safety lock out relay.....	KS
Pump-down control low pressure switch ..	LP
High pressure safety switch.....	HPs
Fused disconnect	Q1
Fuses	F1
Compressor motor	M
Discharge gas thermostat	DGT

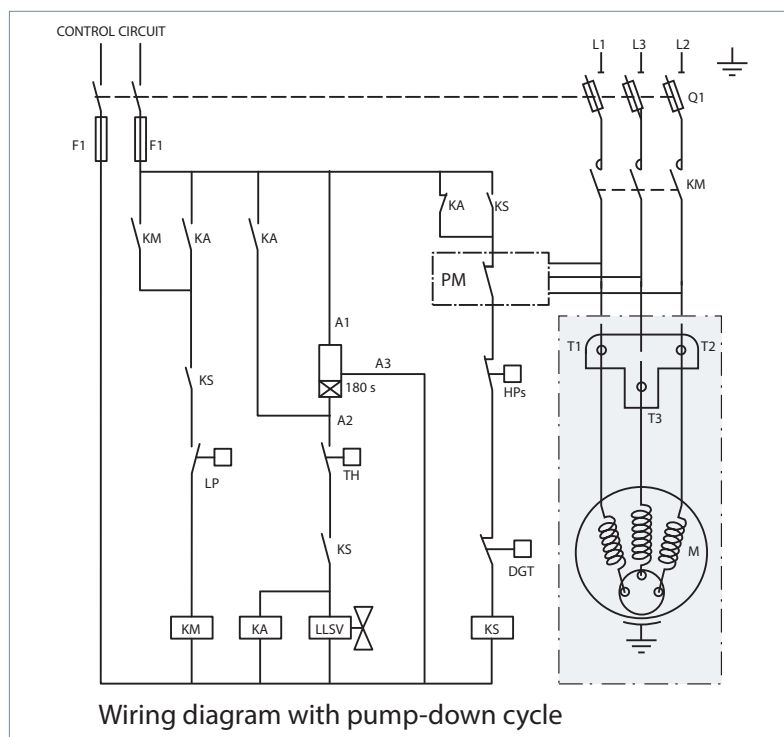

Note:

For H-series compressor, phase monitors are mandatory. The selected phase monitor should lock out the compressor from operation in reverse.

Control logic

Safety control logic requirements

	Tripping conditions		Re-start conditions	
	Value	Time	Value	Time
HP switch	See Pressure settings table from section "Manage operating envelope"	Immediate, no delay. No by-pass	Conditions back to normal. Switch closed again	Manual reset
LP safety switch				Maximum 5 auto reset during a period of 12 hours, then manual reset.
Electronic module (Motor protection, DGT)				Contact M1-M2 opened

Cycle rate limit requirements

Danfoss requires a minimum compressor running time of 2 minutes to ensure proper oil return and sufficient motor cooling. Additionally, compressor service life is based on a maximum of 12 starts per hour.

Therefore, to guarantee these 2 requirements, a three-minute (180- sec) time out is recommended.

Oil management logic recommendations

In some cases, oil management can be enhanced by control logic:

If oil return test failed, a function can be integrated in control to run all compressors simultaneously during one minute every hour in order to boost oil return. Time and delay can be fine-tuned by oil return test N°1. Manage oil in the circuit. During oil boost, pay special attention to superheat management to avoid liquid flood back and foaming.

If after running long time in full load, oil unbalance appears, then a function can be in control to stop all compressors in manifold during one minute every two hours in order to balance oil between compressors. Time and delay can be fine-tuned by Oil balancing test N°2. Manage oil in the circuit.

Control logic

Defrost logic recommendations

In reversible systems, the defrost logic can be worked out to limit liquid flood back effect by:

1. Running full load during defrost to share liquid refrigerant between all compressors.

2. Transferring liquid refrigerant from one exchanger to the other one thanks to pressures.

The following defrost logic combines both advantages:

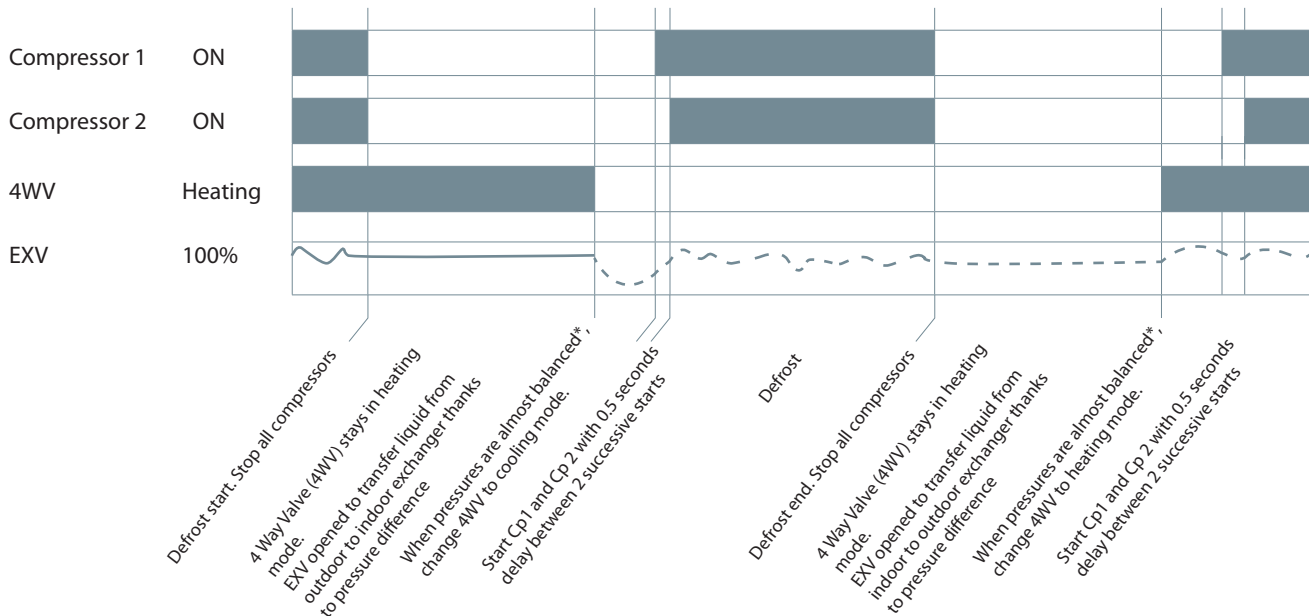

* EXV Opening degree and time have to be set to keep a minimum pressure for 4 way valve moving. In any case, defrost logics must respect requirements and tests described in sections "Manage superheat" and "Manage operating envelope".

Pump-down logic recommendations

Pump down is initiated prior to shutting down the last compressor on the circuit by de-energizing a liquid line solenoid valve or closing electronic expansion valve. When suction pressure reached the cut-out pressure, compressor is stopped, and liquid solenoid valve or electronic expansion valve remains closed.

Two types of pump-down exist:

- One shot pump down (preferred): when last compressor of the circuit stops, suction pressure is decreased 1.5 bar (R22,R407C), 2.5 bar (R410A) below nominal evaporating pressure. Even if suction pressure increases again, the compressor will not restart.
- Continuous pump-down: traditional pump-down, Compressor restarts automatically when suction pressure increases. A non-return valve in the discharge line is recommended.

Reduce moisture in the system

	<p>Excessive air and moisture</p> <ul style="list-style-type: none"> • can increase condensing pressure and cause excessively high discharge temperatures. • can create acid giving rise to copper plating. 	<ul style="list-style-type: none"> • can destroy the lubricating properties of the oil. All these phenomena can reduce service life and cause mechanical and electrical compressor failure.
Requirements	<p>H-series compressors are delivered with < 100 ppm moisture level. At the time of commissioning, system moisture content may be up to 100 ppm.</p>	<p>During operation, the filter drier must reduce this to a level between 20 and 50 ppm.</p>
Solutions	<p>To achieve this requirement, a properly sized and type of drier is required. Important selection criteria's include:</p> <ul style="list-style-type: none"> • driers water content capacity, • system refrigeration capacity, • system refrigerant charge. 	<p>For new installations with H-series compressors with polyolester oil, Danfoss recommends using the Danfoss DML (100% molecular sieve) solid core filter drier.</p>

GENERAL INFORMATION

PRODUCT INFORMATION

SYSTEM DESIGN

INTEGRATION INTO SYSTEM

ORDERING INFORMATION

Assembly line procedure

Compressor storage

Store the compressor not exposed to rain, corrosive or flammable atmosphere between -35°C and 70°C when charged with nitrogen and

between -35°C and 55°C when charged with refrigerant.

Compressor holding charge

Each compressor is shipped with a nominal dry nitrogen holding charge between 0.3 and 0.7 bar and is sealed with elastomer plugs.

- ⚠ Respect the following sequence:
 - Remove the nitrogen holding charge via the suction Schrader valve to avoid an oil mist blow out.

- Remove the suction plug first and the discharge plug afterwards to avoid discharge check valve gets stuck in open position. An opened compressor must not be exposed to air for more than 20 minutes to avoid moisture is captured by the PVE oil.

Handling

- ⚠ Each Danfoss H-series scroll compressor is equipped with the lift ring on the top shell and ring for the discharge port.
- Always use both these rings when lifting the compressor.
- Use lifting equipment rated and certified for the weight of the compressor or compressor assembly.
- A spreader bar rated for the weight of the compressor is highly recommended to ensure a better load distribution.
- The use of lifting hooks closed with a clasp is recommended.

- For tandem and trio assemblies, use a spreader bar and all compressor rings as shown in picture below.
- Never use the lift rings on the compressor to lift the full unit.

Maintain the compressor in an upright position during all handling manoeuvres (maximum of 15° from vertical).

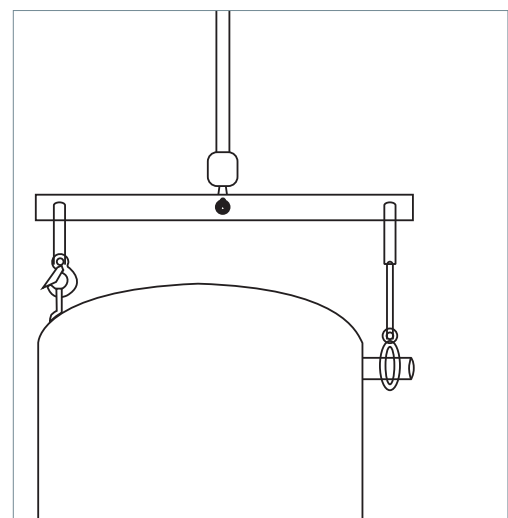

Piping assembly

Good practices for piping assembly is a pre-requisite to ensure compressor service life.

System cleanliness

Circuit contamination possible cause:	Requirement:
Brazing and welding oxides	During brazing, flow nitrogen through the system
Filings and particles from the removal of burrs in pipe-work	Remove any particles and burrs generated by tube cutting and hole drilling
Moisture and air	Use only clean and dehydrated refrigeration grade copper tubing Opened compressor must not be exposed to air more than 20 minutes to avoid moisture captured by POE oil.

Brazing procedure:

- Brazing operations must be performed by qualified personnel.
- Make sure that no electrical wiring is connected to the compressor.
- To prevent compressor shell and electrical box overheating, use a heat shield and/or a heat-absorbent compound.
- Clean up connections with degreasing agent
- Flow nitrogen through the compressor.
- Use flux in paste or flux coated brazing rod.

- Use brazing rod with a minimum of 5% silver content.
- It is recommended to use double-tipped torch using acetylene to ensure a uniform heating of connection.
- To enhance the resistance to rust, a varnish on the connection is recommended.

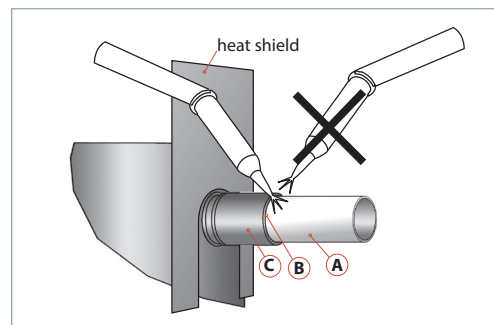

! Before eventual un-brazing of the compressor or any system component, the refrigerant charge must be removed.

System pressure test and leak detection

- !** The compressor has been strength tested and leak proof tested (<3g/year) at the factory. For system tests:
- Always use an inert gas such as Nitrogen or Helium.

- Pressurize the system on HP side first then LP side.
- Do not exceed the following pressures:

Maximum compressor test pressures	
Maximum compressor test pressure high side (HP)	45 bar (g), Do keep the low side pressure not exceed 31.1 bar(g)
Maximum compressor test pressure low side (LP)	31.1 bar (g)

Assembly line procedure

Vacuum evacuation and moisture removal

Requirements:

- Never use the compressor to evacuate the system.
- Connect a vacuum pump to both the LP and HP sides.
- Evacuate the system to a pressure of 500 $\mu\text{m Hg}$ (0.67 mbar) absolute.

Recommendations:

- Energized heaters improve moisture removal.
- Alternate vacuum phases and break vacuum with Nitrogen to improve moisture removal.

For more detailed information see "Vacuum pump-down and dehydration procedure" TI-026-0302.

Refrigerant charging



Initial charge:

- For the initial charge, the compressor must not run.
- Charge refrigerant as close as possible to the nominal system charge.
- This initial charging operation must be done in liquid phase between the condenser outlet and the filter drier.

If needed, a complement of charge can be done:

- In liquid phase while compressor is running by slowly throttling liquid in.
- On the low pressure side, as far away as possible from the compressor suction connection.
- Never bypass safety low pressure switch.

For more detailed information see "Recommended refrigerant system charging practice" FRCC.EN.050.

Dielectric strength and insulation resistance tests

The tests are performed on each compressor at the factory between each phase and ground.

- Dielectric strength test is done with a high potential voltage (hi-pot) of $2U_n + 1000\text{V AC}$ at least, and leakage current must be less than 5 mA. Additional tests of this type are not recommended as it may reduce motor lifetime. Nevertheless, if such a test is necessary, it must be performed at a lower voltage.

- Insulation resistance is measured with a 500 V DC megohm tester and must be higher than 1 megohm.

- The presence of refrigerant around the motor windings will result in lower resistance values to ground and higher leakage current readings. Such readings do not indicate a faulty compressor. To prevent this, the system can be first operated briefly to distribute refrigerant.



Do not use a megohm meter nor apply power to the compressor while it is under vacuum as this may cause internal damage.

Commissioning

Preliminary check



Check electrical power supply:

- Phase order: For H-series compressors, reverse rotation is obvious if the compressor do not build up pressure and sound level is abnormal high. For more details refer to section "Motor protection".

- Voltage and voltage unbalance within tolerance: For more details refer to section "Motor voltage".

Initial start-up

- Crankcase heaters must be energized at least 8 hours in advance to remove refrigerant.
- A quicker start-up is possible by "jogging" the compressor to evacuate refrigerant.

Start the compressor for 1 second, then wait for 1 to 2 minutes. After 3 or 4 jogs the compressor can be started. This operation must be repeated for each compressor individually.

System monitoring

The system must be monitored after initial startup for a minimum of 60 minutes to ensure proper operating characteristics such as:

- Correct superheat and subcooling.
- Current draw of individual compressors within acceptable values (max operating current).
- No abnormal vibrations and noise.
- Correct oil level.

If Oil Top-up is needed, it must be done while the compressor is idle. Use the schrader connector or any other accessible connector on the compressor suction line. Always use new cans. For more detailed information see "Lubricants filling in instructions for Danfoss Commercial Compressors" T1 2-025-0402.

Oil level checking and top-up

In installations with good oil return and line runs up to 50 ft, no additional oil is required. If installation lines exceed 50 ft, additional oil may be needed. 1 or 2% of the total system refrigerant charge (in weight) can be used to roughly define the required oil top-up quantity.

Always use oil from new cans. Top-up the oil while the compressor is idle. Use any accessible connector on the compressor suction line and a suitable pump.

Dismantle and disposal

GENERAL INFORMATION
PRODUCT INFORMATION
SYSTEM DESIGN
INTEGRATION INTO SYSTEM
ORDERING INFORMATION



Danfoss recommends that compressors and compressor oil should be recycled by a suitable company at its site.

Ordering information and packaging

Packaging

Single pack

Compressors are packed individually in a cardboard box. They can be ordered in any quantity. Minimum ordering quantity = 1. As far as possible, Danfoss will ship the boxes on full pallets of 9 compressors according below table.

- Each box also contains following accessories:
- 4 grommets
- 4 assemblies of self tapping US thread bolts, washers and sleeves
- 4 additional sleeves
- 1 screw for earth connection
- Run capacitors are not provided

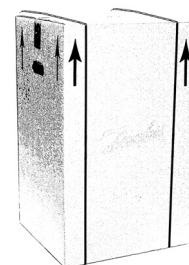

Industrial pack

Compressors are not packed individually but are shipped all together on one pallet. They can be ordered in quantities of full pallets only, multiples of 12 compressors, according below table.

Each industrial pack pallet contains following accessories:

- 4 grommets per compressor
- 4 sleeves per compressor
- 1 screw for earth connection per compressor

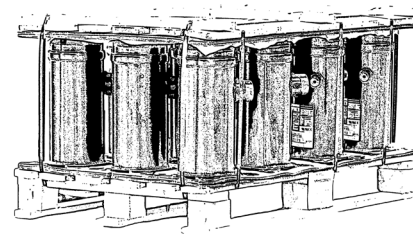

Packaging details

Delivered region	Packaging	Nbr	Pallet type	Comments
All	Single pack	9	Danfoss pallet	-
	Industrial pack	12	Danfoss pallet	-

* Nbr : number of compressors/pallet

Ordering information and packaging

Compressor code numbers

Danfoss H-series scroll compressors can be ordered in either industrial packs or in single packs.

Please use the code numbers from below tables for ordering.

R22 Single pack

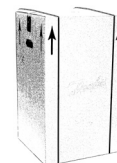

Compressors	Model Variation	Connections	Features	Code no.					
				1	2	4	5	7	9
HRM034	T	P	6			121L2367	121L2122		
HRM038	U	P	6	121L0931	121L1091		121L2372		
	T	P	6			121L2372			121L2092
HRM042	T	P	6			121L2127			
HRM047	U	P	6	121L0951	121L1131	121L1051	121L0991		
	T	P	6						121L2097
HRM051	T	P	6			121L1676			
HRM054	T	P	6			121L2752			
	U	P	6		121L1871				
HRM058	U	P	6			121L1711			
HRM060	T	P	6	121L1541	121L2760	121L1721			121L2082
	T	C	8			121L3072			
	U	C	6		121L2077				
HLM072	U	P	6		121L1881				
	T	C	6			121L1751			121L1856
HLM075	T	C	8			121L2067			
	T	C	6		121L1901	121L1761			
HLM081	T	C	6		121L1911	121L1776			121L2102
	T	C	8			121L2009			
HCM094	T	C	6		121L0891	121L0581			
HCM109	T	C	6			121L0366			
HCM120	T	C	6		121L0761	121L0391			

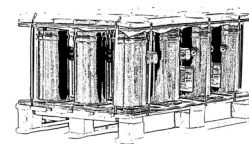
R22 Industrial pack

Compressors	Model Variation	Connections	Features	Code no.					
				1	2	4	5	7	9
HRM034	T	P	6			121L2364	121L2119		
HRM038	T	P	6			121L2369			121L2089
	U	P	6	121L0928	121L1091		121L0963		
HRM042	T	P	6			121L2124			
HRM047	T	P	6						121L2094
	U	P	6	121L0948	121L1128	121L1048	121L0988		
HRM051	T	P	6			121L1673			
	T	P	6			121L2749			
HRM054	U	P	6		121L1868				
	U	P	6			121L1708			
HRM058	T	P	6	121L1538	121L2757	121L1718			121L2079
	T	C	8			121L3071			
HRM060	U	C	6		121L2074				
	U	P	6		121L1878				
	T	C	6			121L1748			121L1853
HLM072	T	C	8			121L2064			
	T	C	6		121L1898	121L1758			
HLM075	T	C	6		121L1908	121L1773			121L2099
	T	C	8			121L2006			
HCM094	T	C	6		121L0888	121L0578			
HCM109	T	C	6			121L0363			
HCM120	T	C	6		121L0758	121L0388			

GENERAL INFORMATION
PRODUCT INFORMATION
SYSTEM DESIGN
INTEGRATION INTO SYSTEM
ORDERING INFORMATION

Ordering information and packaging

R407C Single pack

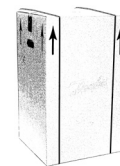

Compressors	Model Variation	Connections	Features	Code no.						
				1	2	4	5	7	9	
HRP025	T	P	6	121L3086		121L3088				
HRP032	T	P	6	121L3345						
HRP034	T	P	6	121L3092	121L3355	121L2024				
HRP038	T	P	6	121L3353	121L1086	121L1006				
HRP040	T	P	6		121L1096	121L1016	121L1929			
HRP042	T	P	6	121L3094	121L1106	121L1026				
HRP045	T	P	6			121L1036				
HRP047	T	P	6	121L3347	121L1126	121L1046				
HRP051	T	P	6	121L1501		121L1681				
HRP054	T	P	6	121L3349	121L3351	121L1691	121L2197			
	T	C	6			121L3184				
HRP058	T	P	6			121L1701				
	T	C	6		121L3275					
HRP060	T	C	6	121L3274						
	T	P	6	121L3070	121L2297	121L1726	121L1606			
HLP068	T	C	6		121L3276	121L2014				
HLP072	T	C	6		121L2903	121L1756				
	T	C	8			121L2072				
	T	P	6				121L1631			
HLP075	T	C	6		121L3098	121L1766				
	T	P	6		121L3277	121L2919				
HLP078	T	C	6			121L2454				
HLP081	T	C	6		121L1916	121L1781				
	T	C	8		121L3340	121L1786				
HCP081	T	C	6			121L0571				
HCP094	T	C	6		121L0906	121L0601				
	T	C	8		121L0916	121L0611				
HCP109	T	C	6			121L0376				
	T	C	8			121L0386				
HCP120	T	C	6		121L0766	121L0401				
	T	C	8			121L0411				

Ordering information and packaging

R407C Industrial pack

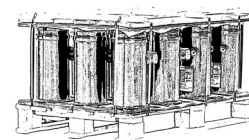

Compressors	Model Variation	Connections	Features	Code no.						
				1	2	4	5	7	9	
HRP025	T	P	6	121L3085		121L3087				
HRP032	T	P	6	121L3344						
HRP034	T	P	6	121L3091	121L3354	121L2021				
HRP038	T	P	6	121L3352	121L1083	121L1003				
HRP040	T	P	6		121L1093	121L1013	121L1926			
HRP042	T	P	6	121L3093	121L1103	121L1023	121L2154			
HRP045	T	P	6			121L1033				
HRP047	T	P	6	121L3346	121L1123	121L1043				
HRP051	T	P	6	121L1498		121L1678				
HRP054	T	P	6	121L3348	121L3350	121L1688	121L2194			
	T	C	6			121L3183				
HRP058	T	P	6			121L1698				
	T	C	6							
HRP060	T	P	6	121L3068	121L2294	121L1723	121L1603			
HLP068	T	C	6		121L3273	121L2011				
HLP072	T	C	6		121L2900	121L1753				
	T	C	8			121L2069				
	T	P	6				121L1628			
HLP075	T	C	6		121L3097	121L1763				
	T	P	6							
HLP078	T	C	6							
HLP081	T	C	6		121L1913	121L1778				
	T	C	8			121L1783				
HCP081	T	C	6			121L0568				
HCP094	T	C	6		121L0903	121L0598				
	T	C	8		121L0913	121L0608				
HCP109	T	C	6			121L0373				
	T	C	8			121L0383				
HCP120	T	C	6		121L0763	121L0398				
	T	C	8			121L0408				

GENERAL INFORMATION

PRODUCT INFORMATION

SYSTEM DESIGN

INTEGRATION INTO SYSTEM

ORDERING INFORMATION

Ordering information and packaging

R410A Single pack

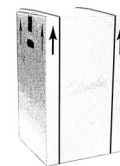

Compressors	Model Variation	Connections	Features	Code no.					
				1	2	4	5	7	9
HRH029	U	P	6	121L2277	121L2282	121L2287	121L3100		
HRH032	U	P	6	121L1141	121L1256	121L1196	121L1171	121L1221	
HRH034	U	P	6	121L1146	121L1261	121L2446	121L2650		
HRH036	U	P	6	121L1151	121L1266	121L1201	121L1176	121L1231	121L2666
HRH038	U	P	6	121L1156	121L1271	121L1206			121L2658
HRH040	U	P	6	121L1161	121L1276	121L1211	121L1186	121L1241	
HRH041	U	P	6	121L1281		121L1356			
	U	C	8		121L2407	121L2397			
HRH044	U	P	6	121L1286	121L1456	121L1361		121L1411	
	U	C	8			121L3106			
HRH047	U	P	6			121L2851			
HRH048	U	P	6	121L2582	121L2776	121L2772			
HRH049	U	P	6	121L1291		121L1366			
	U	C	8		121L2482	121L2474		121L2478	
HRH051	U	P	6	121L1296	121L1466	121L1371	121L1326	121L1421	
HRH054	U	P	6	121L1301	121L1471	121L1376	121L1331	121L1426	121L2984
	U	C	8		121L3082	121L3033		121L3111	
HRH056	U	C	6	121L2732		121L1386			
	U	P	6	121L1306	121L1476	121L1381		121L1431	
	U	C	8			121L2764			
HLH061	T	P	6	121L2042					
	T	C	6		121L2062	121L2052		121L2057	121L2450
	T	C	8		121L2494	121L2486		121L2490	
HLH068	T	C	6	121L2818	121L1481	121L1391	121L2830	121L1436	121L2988
	T	P	6	121L1311			121L1341		
	T	C	8		121L2427	121L2417		121L2422	
HLJ072	T	C	6	121L2736	121L1486	121L1396		121L2037	121L2992
	T	P	6	121L1316			121L1346		
HLJ075	T	C	8		121L2177	121L2167		121L2498	
	T	C	6		121L2272	121L2267		121L2262	
HLJ083	T	P	6	121L1321					
	T	C	6		121L1491	121L1401		121L1441	121L2387
	T	C	8		121L2182	121L2172		121L2502	121L3337
HCJ091	T	C	6			121L3113			
	T	C	8			121L3119			
HCJ106	T	C	6			121L3115			
	T	C	8			121L3121			
HCJ121	T	C	6			121L3117			
	T	C	8			121L3123			

Ordering information and packaging

R410A Industrial pack

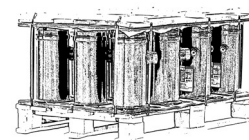

Compressors	Model Variation	Connections	Features	Code no.					
				1	2	4	5	7	9
HRH029	U	P	6	121L2274	121L2279	121L2284	121L3099		
HRH032	U	P	6	121L1138	121L1253	121L1193	121L1168	121L1218	
HRH034	U	P	6	121L1143	121L1258	121L2443	121L2647		
HRH036	U	P	6	121L1148	121L1263	121L1198	121L1173	121L1228	121L2663
HRH038	U	P	6	121L1153	121L1268	121L1203			121L2655
HRH040	U	P	6	121L1158	121L1273	121L1208	121L1183	121L1238	
HRH041	U	P	6	121L1278		121L1353			
	U	C	8		121L2404	121L2394			
HRH044	U	P	6	121L1283	121L1453	121L1358		121L1408	
	U	C	8			121L3105			
HRH047	U	P	6			121L2848			
HRH048	U	P	6	121L2579	121L2773	121L2769			
HRH049	U	P	6	121L1288		121L1363			
	U	C	8		121L2479	121L2471		121L2475	
HRH051	U	P	6	121L1293	121L1463	121L1368	121L1323	121L1418	
HRH054	U	P	6	121L1298	121L1468	121L1373	121L1328	121L1423	121L2981
	U	C	8		121L3081	121L3030			
HRH056	U	C	6	121L2729		121L1383			
	U	P	6	121L1303	121L1473	121L1378		121L1428	
HRH061	U	C	8			121L2761			
	T	P	6	121L2039					
	T	C	6		121L2059	121L2049		121L2054	121L2447
HLH068	T	C	8		121L2491	121L2483		121L2487	
	T	C	6	121L2815	121L1478	121L1388	121L2827	121L1433	121L2985
	T	C	8		121L2424	121L2414		121L2419	
HLJ072	T	P	6	121L1308			121L1338		
	T	C	6	121L2733	121L1483	121L1393		121L2034	121L2989
	T	C	8		121L2174	121L2164		121L2495	
HLJ075	T	P	6	121L1313			121L1343		
	T	C	6		121L2269	121L2264		121L2259	
HLJ083	T	P	6	121L1318					
	T	C	6		121L1488	121L1398		121L1438	121L2384
HCJ091	T	C	8		121L2179	121L2169		121L2499	121L3334
	T	C	6			121L3112			
HCJ106	T	C	8			121L3118			
	T	C	6			121L3114			
HCJ121	T	C	8			121L3120			
	T	C	6			121L3116			
	T	C	8			121L3122			

GENERAL INFORMATION

PRODUCT INFORMATION

SYSTEM DESIGN

INTEGRATION INTO SYSTEM

ORDERING INFORMATION

Spare parts & accessories

Run capacitors for PSC wiring



Type	Code n°	Description	Application	Packaging	Pack size
70 µF	120Z0051	PSC wiring Run Capacitor 70 µF,	50Hz, Motor Code 5: HRM025-042/HRP025-042/HRH029-036 60HZ, Motor Code 1 : HRM051-054/HRP051/HRH041-HRH051	Multipack	10
60 µF	120Z0050	PSC wiring Run Capacitor 60 µF,	50Hz, Motor Code 5: HRM045-047/HRP045-047/HRH038-040 60Hz, Motor Code 1 : HRM040-048/HRH038-HRH040	Multipack	10
55 µF	8173234	PSC wiring Run Capacitor 55 µF,	50Hz, Motor Code 5: HRM054-HLM081/HRP054-HLP081/ HRH051-HLJ083	Multipack	10
50 µF	8173233	PSC wiring Run Capacitor 50 µF,	60Hz, Motor Code 1 : HRM058-060/HRH036	Multipack	10
45 µF	8173232	PSC wiring Run Capacitor 45 µF,	50Hz, Motor Code 5: HRM051/HRP051 60Hz, Motor Code 1 : HRH032-034	Multipack	10
			60Hz, Motor Code 1 : HRM025-034/HRH031	Multipack	10

Start capacitors and starting relay for CSR wiring



Type	Code n°	Description	Application	Packaging	Pack size
145-175 µF	120Z0399	CSR wiring Start Capacitor 145-175 µF,	"50Hz, Motor Code 5: HRM025-047/HRP025-047/HRH029-040 60Hz, Motor Code 1 : HRM025-034/HRH031"	Multipack	10
161-193 µF	120Z0400	CSR wiring Start Capacitor 161-193 µF,	"50Hz, Motor Code 5: HRM051-054/HRP051-054 60Hz, Motor Code 1 : HRM048-054/HRP051/ HRH041-HRH051"	Multipack	10
88-108 µF	8173001	CSR wiring Start Capacitor 88-108 µF,	"50Hz, Motor Code 5: HRM058-HLM081/HRP058-HLP081/ HRH051-HLJ083	Multipack	10
RVA9CKL	120Z0393	CSR wiring Starting Relay, motor voltage code 5 - 220-240V / 1 / 50Hz	60Hz, Motor Code 1 : HRM038-047/HRM058-060/HRH032-40"	Multipack	10
RVA3EKL	120Z0394	CSR wiring Starting Relay, motor voltage code 5 - 220-240V / 1 / 50Hz	HRM/P032-047 HRH031-040	Multipack	10
RVA4GKL	120Z0395	CSR wiring Starting Relay, motor voltage code 5 - 220-240V / 1 / 50Hz	HRM/P051-054	Multipack	10
RVA2ACKL	120Z0396	CSR wiring Starting Relay, motor voltage code 1 -208-230V / 1 / 60Hz	HRM/P058-060 HLM/P068-081 HRH051-056 HLH061- 068 HLJ072-083	Multipack	10
RVA2ABKL	120Z0397	CSR wiring Starting Relay, motor voltage code 1 -208-230V / 1 / 60Hz	HRM/P032-034 HRH031	Multipack	10
RVA4IKL	120Z0398	CSR wiring Starting Relay, motor voltage code 1 -208-230V / 1 / 60Hz	HRM/P038-058U-060U HLM/068-081 HRH032-056, HLH061-068, HLJ072-083	Multipack	10
			HRM058T1-060T1	Multipack	10

Rotolock adaptor set

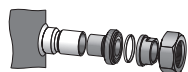

Type	Code n°	Description	Application	Packaging	Pack size
	120Z0126	Rotolock adaptor set (1-1/4" ~ 3/4"), (1" ~ 1/2")	HRP/HRM025-034-038-040-042 HRH029-031-032-034-036038 - group 1	Multipack	6
	120Z0127	Rotolock adaptor set (1-1/4" ~ 7/8"), (1" ~ 1/2")	HRP/HRM045-047-051-057-058- 060-068-072-075 HRH040-041-044-049-051-056- 061-068-072-075-083 - group 2	Multipack	6
	120Z0128	Rotolock adaptor set (1-1/4" ~ 7/8"), (1-1/4" ~ 3/4")	HRM/HRP078-081 - group 3	Multipack	6
	120Z0129	Rotolock adaptor set (1-3/4" ~ 1-1/8"), (1-1/4" ~ 7/8")	HCM/P094-109-120 HCJ090-091- 105-106-120-121 - group 4	Multipack	6

Spare parts & accessories

Rotolock adaptor



Type	Code n°	Description	Application (see above group)	Packaging	Pack size
	120Z0366	Rotolock adaptor (1-1/4" ~ 3/4")	Group 1 suction	Multipack	10
	120Z0367	Rotolock adaptor (1-1/4" ~ 7/8")	Group 2 & 3 suction	Multipack	10
	120Z0364	Rotolock adaptor (1-3/4" ~ 1-1/8")	Group 4 suction	Multipack	10
	120Z0365	Rotolock adaptor (1" ~ 1/2")	Group 1 & 2 discharge	Multipack	10
	120Z0366	Rotolock adaptor (1-1/4" ~ 3/4")	Group 3 discharge	Multipack	10
	120Z0367	Rotolock adaptor (1-1/4" ~ 7/8")	Group 4 discharge	Multipack	10

Crankcase heater



Type	Code No	Description	Application	Packaging	Pack Size
	120Z0055	Belt type crankcase heater, 40 W, 230 V, CE mark	HRM032-034-038-040-042-045-047 - HRP025-038-040-042-045-047 - HRH029-032-034-036-038-040	Multipack	6
	120Z0056	Belt type crankcase heater, 40 W, 400 V, CE mark		Multipack	6
	120Z0057	Belt type crankcase heater, 50 W, 230 V, CE mark	HRM048-051-054-058-060 / HLM068-072-075 - HRP048-051-054-058-060 / HLP068-072-075 - HRH041-049-051-054-056 / HLH061-068 / HLJ072 / HLJ075	Multipack	6
	120Z0058	Belt type crankcase heater, 50 W, 400 V, CE mark		Multipack	6
	120Z0059	Belt type crankcase heater, 65 W, 230 V, CE mark, UL		Multipack	6
	120Z5011	Belt type crankcase heater, 70 W, 230 V, UL, CE mark		Multipack	6
	120Z0060	Belt type crankcase heater, 65 W, 400 V, CE mark, UL	HLM078-081 / HCM094-109-120 - HLP081 / HCP094-109-120 - HLJ083 - HCJ090-091-105-106-120-121	Multipack	6
	120Z5012	Belt type crankcase heater, 70 W, 460 V, UL, CE mark		Multipack	6
	120Z5013	Belt type crankcase heater, 70 W, 575 V, UL, CE mark		Multipack	6

Discharge temperature protection



Type	Code No	Description	Application	Packaging	Pack Size
	7750009	Discharge thermostat kit	All models	Multipack	10
	7973008	Discharge thermostat kit	All models	Industry pack	50

Spare parts & accessories

Lubricant



Type	Code No	Description	Application	Packaging	Pack Size
	120Z5034	PVE (0.95 liter can) 320HV (FVC68D)	HRH, HLH, HLJ, HCJ, HRP, HLP & HCP	Multipack	1

Mounting hardware



Type	Code No	Description	Application	Packaging	Pack Size
	120Z5017	Mounting grommet	All models	Single pack	1
	120Z5014	Mounting sleeve	All models	Single pack	1
	120Z5031	Mounting kit, including 1 bolt, 1 sleeve, 1 washer	All models	Single pack	1
	120Z5064	Mounting kit for 1 scroll compressor including 4 grommets, 4 sleeves, 4 bolts, 4 washers	All models	Single pack	1

Acoustic hoods

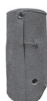

Type	Code No	Description	Application	Packaging	Pack Size
	120Z5083	Acoustic hood	HRM032-047, HRP 032-047, HRH 031-040, HRH047, HRH048, HRH050	Single pack	1
	120Z5084	Acoustic hood	HRM048-081, HRP048-081, HRH044, HRH049, HRH051-056, HLH061-068, HLJ072-083	Single pack	1
	120Z5085	Acoustic hood	HRM094-120, HCP094-120, HCJ090-121	Single pack	1

IP54 upgrade kit



Type	Code No	Description	Application	Packaging	Pack Size
	118U0056	IP54 upgrade kit for round terminal box (P & T version)	HRM, HLM, HCM, HRP, HLP, HCP, HRH, HLH, HLJ	Multipack	6
	118U0057	IP54 upgrade kit for square terminal box (C & Q version)	HRM, HLM, HCM, HRP, HLP, HCP, HRH, HLH, HLJ, HCJ	Multipack	6

Terminal box



Code No	Description	Application	Packaging	Pack Size
120Z5015	Round terminal box (P & T version)	P and T version	Multipack	10
120Z5018	Square terminal box (C & Q version)	C and Q version	Multipack	10

Danfoss Commercial Compressors

is a worldwide manufacturer of compressors and condensing units for refrigeration and HVAC applications. With a wide range of high quality and innovative products we help your company to find the best possible energy efficient solution that respects the environment and reduces total life cycle costs.

We have 40 years of experience within the development of hermetic compressors which has brought us amongst the global leaders in our business, and positioned us as distinct variable speed technology specialists. Today we operate from engineering and manufacturing facilities spanning across three continents.



Danfoss Scrolls



Danfoss Inverter Scrolls



Danfoss Turbocor Compressors



Danfoss Light Commercial Refrigeration Compressors



Danfoss Maneurop Reciprocating Compressors



Danfoss Optyma Condensing Units

Our products can be found in a variety of applications such as rooftops, chillers, residential air conditioners, heatpumps, coldrooms, supermarkets, milk tank cooling and industrial cooling processes.

Danfoss A/S
Climate Solutions • danfoss.com • +45 7488 2222



Any information, including, but not limited to information on selection of product, its application or use, product design, weight, dimensions, capacity or any other technical data in product manuals, catalogues descriptions, advertisements, etc. and whether made available in writing, orally, electronically, online or via download, shall be considered informative, and is only binding if and to the extent, explicit reference is made in a quotation or order confirmation. Danfoss cannot accept any responsibility for possible errors in catalogues, brochures, videos and other material. Danfoss reserves the right to alter its products without notice. This also applies to products ordered but not delivered provided that such alterations can be made without changes to form, fit or function of the product. All trademarks in this material are property of Danfoss A/S or Danfoss group companies. Danfoss and the Danfoss logo are trademarks of Danfoss A/S. All rights reserved.