



# Solenoid valve

## EV210BW

Direct-operated for drinking water

## Description

EV210BW 1.5, 2, 3, 4.5 & 6 covers a wide range of direct-operated 2/2-way solenoid valves for universal use.

EV210BW is a very robust high performance valve program. This valve type is designed with EPDM seal, lead free dezincification resistant Eco brass for drinking water. It can be used in all kind of tough working conditions in demanding industrial applications:

- For water supply and control
- Dosing application
- Food processing
- Water treatment / Reverse Osmosis.

## Features & benefits

- For drinking water
- Clip on coil
- Ambient temperature: Up to 80 °C
- Coil enclosure: Up to IP67
- Body material in Eco brass (Lead % by weight < 0.1%)
- New generation EPDM sealings recommended for drinking water

## Applications

It is recommended to use a filter in front of the valve. Recommended filter 50 mesh (297 microns).

**Figure: Filter**

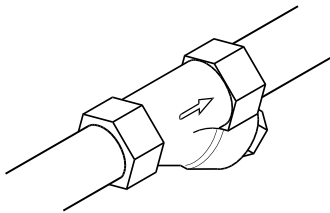

In water applications, exercise the valves at least once every 24 hours, meaning change the state of the valve. The valve exercise will minimize the risk of the valve sticking due to calcium carbonate, zinc or iron oxide build-up.

**Figure: Exercise - Valve on/of**

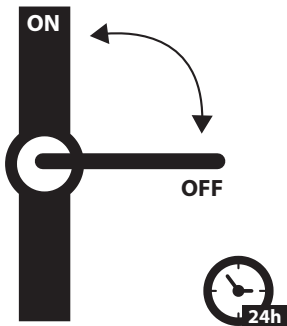

## Guidelines for water

To minimize scaling, and corrosion attack it is recommended that the water passing the valve have the following values:

- Hardness 6 – 18 °dH to avoid scaling (chalk / lime stone build up).
- Conductivity 50 – 800 µS/cm to avoid brass dezincification and corrosion.
- Above 25 °C media temperature avoid stagnant water inside the valve to avoid dezincification and corrosion attack.
- Drinking water (Ph 6 – 9)

## Ordering

### Product code numbers

Connection type	Connection size [in]	Orifice size [mm]	Kv value [m <sup>3</sup> /h]	Seal Material	Function	Code number
G	1/8	1.50	0.080	EPDM	NC	132U2100
G	1/8	1.50	0.080	EPDM	NO	132U2101
G	1/8	1.50	0.080	EPDM	NC	132U2102
G	1/4	1.50	0.080	EPDM	NC	132U2154
G	1/4	2.00	0.150	EPDM	NC	132U2300
G	1/4	2.00	0.150	EPDM	NO	132U2301
G	1/4	3.00	0.300	EPDM	NC	132U3000
G	1/4	3.00	0.300	EPDM	NO	132U3001
G	1/8	3.00	0.300	EPDM	NC	132U3002
G	1/4	3.00	0.300	EPDM	NC	132U3004
G	3/8	3.00	0.300	EPDM	NC	132U3006
G	1/4	3.00	0.300	EPDM	NC	132U3054
G	3/8	4.50	0.550	EPDM	NC	132U4400
G	3/8	4.50	0.550	EPDM	NO	132U4401
G	3/8	4.50	0.550	EPDM	NC	132U4404
G	1/4	4.50	0.550	EPDM	NC	132U4406
G	1/4	4.50	0.550	EPDM	NO	132U4407
G	1/4	4.50	0.550	EPDM	NC	132U4408
G	1/4	4.50	0.550	EPDM	NC	132U4452
G	1/4	6.00	0.700	EPDM	NC	132U4500
G	3/8	6.00	0.700	EPDM	NC	132U4502

### Accessories code numbers

#### Coil

Figure: BB, clip on



Table: BB, clip on

Type	T <sub>ambient</sub>	Supply voltage	Voltage variation	Frequency	Control	Power consumption		Code no.
	[°C]	[V]		[Hz]		[W]	[VA]	
BB024AS	-40 – 80	24	-15%, +10%	50	NC, NO	11	19	018F7358
BB230AS	-40 – 80	220 – 230	-15%, +10%	50	NC, NO	11	19	018F7351
BB012DS	-40 – 50	12	±10%	DC	NC, NO, UN (Latching)	13	–	018F7396
BB024DS	-40 – 50	24	±10%	DC	NC, NO, UN (Latching)	16	–	018F7397

Figure: EEC Electronic coil controller



Table: EEC Electronic coil controller

Type	T <sub>ambient</sub>	Supply voltage	Voltage variation	Frequency	Control	Power consumption	Code no.
	[°C]	[V]		[Hz]		[W]	
BE240CS	-25 – 55	208 – 240	±10%	60	NC, NO	4	018F6783
		208 – 240	±10%	50		4	

Figure: Cable plug



Table: Cable plug

Cable plug size	Description	Code no.
DIN 18	Cable plug IP67	042N1256

## Universal electronic multi-timer Type ET 20 M

Figure: Type ET 20 M



Table: Type ET 20 M

Type	Voltage	Suitable for coil types	Code no.
	[V]		
BA024A	24 – 240	AL, AM, AS, AZ, BA, BD, BB	042N0185

## Spare parts code numbers



Table: Spare part kits DN 1.5 to DN 6

Type	Actuator kit NC	Actuator kit NO
EV210BW DN 1.5	132U8080	132U8003
EV210BW DN 2.0 – 4.5	132U8002	132U8003
EV210BW DN 6	132U8006	-
	<ul style="list-style-type: none"> <li>1. 4 x Screws</li> <li>2. Armature tube</li> <li>3. Armature + spring</li> <li>4. O-ring</li> </ul>	<ul style="list-style-type: none"> <li>1. 4 x Screws</li> <li>2. NO actuator kit</li> <li>3. O-ring</li> </ul>

## Overview

### Product portfolio

Table: Portfolio overview

Features	EV210BW NC	EV210BW NO
		
<b>Body material</b>	Eco brass	Eco brass
<b>DN [mm]</b>	1.5 – 6	1.5 – 4.5
<b>Connection</b>	G $\frac{1}{8}$ – G $\frac{3}{8}$	G $\frac{1}{8}$ – G $\frac{3}{8}$
<b>Sealing material</b>	EPDM	EPDM
<b>Function</b>	NC	NO
<b>K<sub>v</sub> [m<sup>3</sup>/h]</b>	0.08 – 0.7	0.08 – 0.55
<b>Differential pressure range [bar]</b>	0 – 10	0 – 10
<b>Temperature range [°C]</b>	-30 – 90	-30 – 90

## Functions

### Function, NC

#### Coil voltage disconnected (closed)

When the voltage to the coil (5) is disconnected, the armature (2) with the valve plate (3) is pressed down against the valve orifice (4) by the closing spring (1) and the medium pressure. The valve will be closed for as long as the voltage to the coil is disconnected.

#### Coil voltage connected (open)

When voltage is applied to the coil (5), the armature (2) with the valve plate (3) is lifted clear of the valve orifice (4). The valve is now open for unimpeded flow and will be open for as long as there is voltage to the coil.

Figure: Function, NC

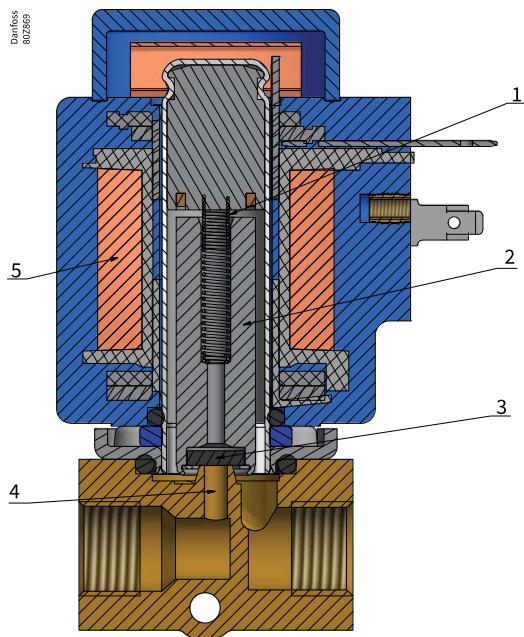

1	Closing spring
2	Armature
3	Valve plate
4	Valve orifice
5	Coil

## Function, NO

### Coil voltage disconnected (valve is open)

When the voltage to the coil (8) is disconnected, the valve orifice (5) is open, the opening spring (2) lifting the spindle (3) with the valve plate (4) clear of the orifice. The valve will be open for as long as the supply voltage to the coil is disconnected.

### Coil voltage connected (valve is closed)

When voltage is applied to the coil (8), the magnetic field draws the valves armature (1) down to touch the fixed base (7). The spindle (3) with the valve plate (4) is now pressed down against the valve orifice (5) by the closing spring (6). The valve will be closed for as long as there is voltage to the coil.

Figure: Function, NO

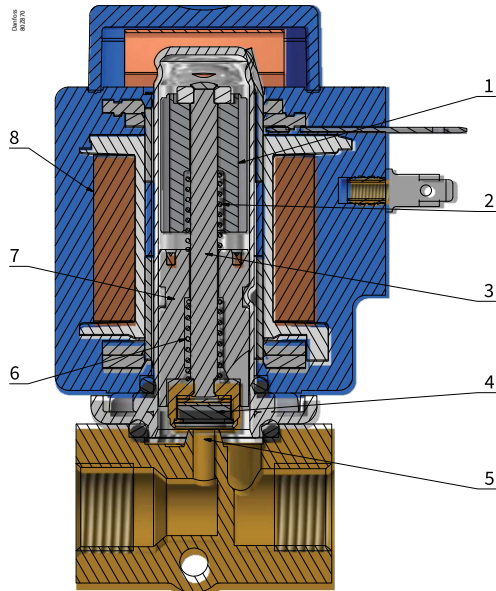

1	Armature
2	Opening spring
3	Spindle
4	Valve plate
5	Valve orifice
6	Closing spring
7	Fixed base
8	Coil

## Product details

### General data

Table: Technical data

<b>Media</b>	EPDM	Drinking water
<b>Media temperature</b>	EPDM	-30 – 90 °C
<b>Ambient temperature</b>	Up to 50 °C	
<b>K<sub>v</sub> value</b>	DN1.5	0.08 m <sup>3</sup> /h
	DN2	0.15 m <sup>3</sup> /h
	DN3	0.30 m <sup>3</sup> /h
	DN4.5	0.55 m <sup>3</sup> /h
	DN6	0.70 m <sup>3</sup> /h
<b>Min. Opening differential pressure</b>	0 bar	
<b>Max. Opening differential pressure</b>	Up to 10 bar	
<b>Max. working pressure</b>	Up to 10 bar (Equal to max. differential pressure)	
<b>Max. test pressure</b>	15 bar	
<b>Viscosity</b>	Max. 50 cSt	

Table: Time to open/close

Type	EV210BW 1.5	EV210BW 2 NC	EV210BW 2 NO	EV210BW 3	EV210BW 4.5	EV210BW 6
Time to open[ms] <sup>(1)</sup>	10	10	20	20	20	20
Time to Close[ms] <sup>(1)</sup>	20	20	20	20	20	20

<sup>(1)</sup>The time is identical and apply to water. The exact time will depend on the pressure conditions.

### Materials

Table: Materials

Components	Materials	Specifications
Valve body	Eco brass	CW724R
Armature	Stainless steel	W.no. 1.4105 / AISI 430 FR
Armature tube	Stainless steel	W.no. 1.4306 / AISI 304 L
Armature stop	Stainless steel	W.no. 1.4105 / AISI 430 FR
Springs	Stainless steel	W.no. 1.4310 / AISI 301
Valve plate	EPDM	
O-ring	EPDM	

## Capacity

**Example, water at low pressure:** Capacity for EV210BW 1.5B at differential pressure of 10 mbar. Approx. 0.08 l / min

**Figure: Water at low pressure**

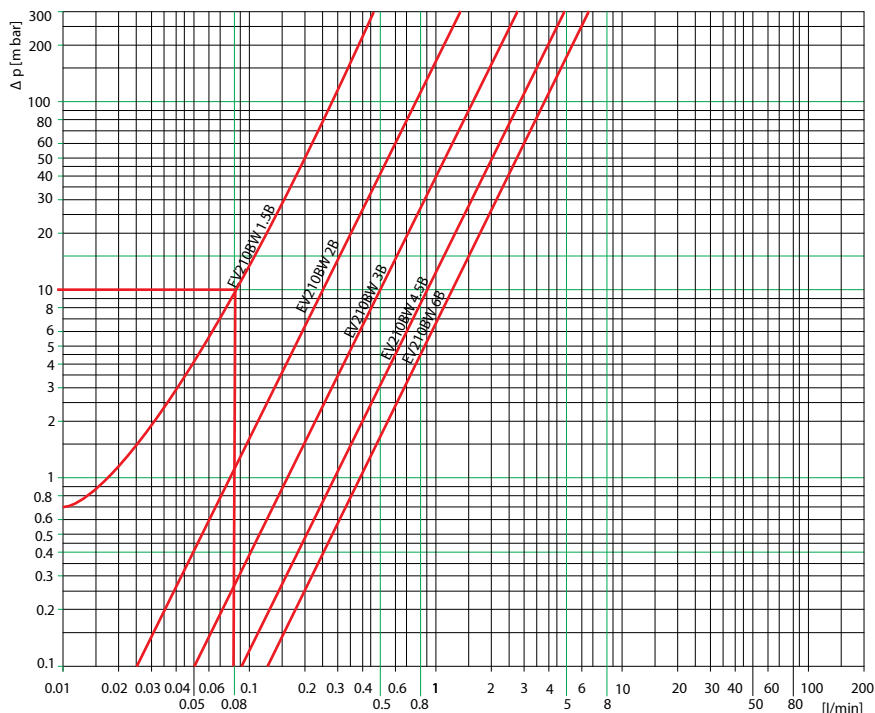

**Example, water at higher pressure:** Capacity for EV210BW 1.5B at differential pressure of 1.5 bar. Approx. 0.1 m<sup>3</sup> / h

**Figure: Water at higher pressure**

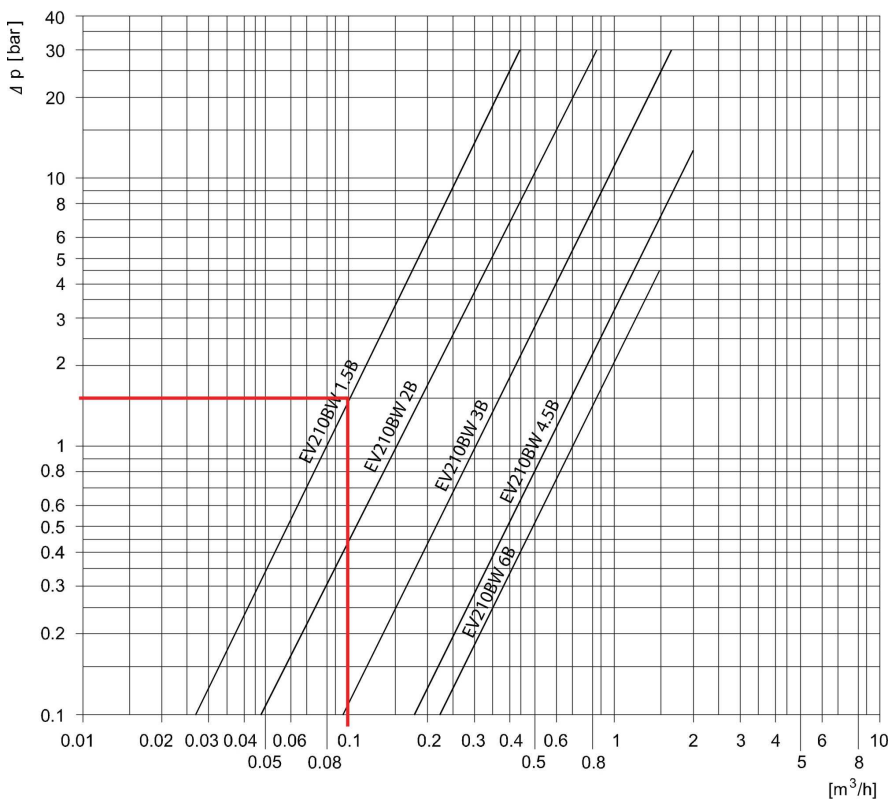

**Example, air at lower pressure:** Capacity for EV210BW 2B at differential pressure of 8 mbar. Approx. 0.35 Nm<sup>3</sup> / h

**Figure: Air at lower pressure**

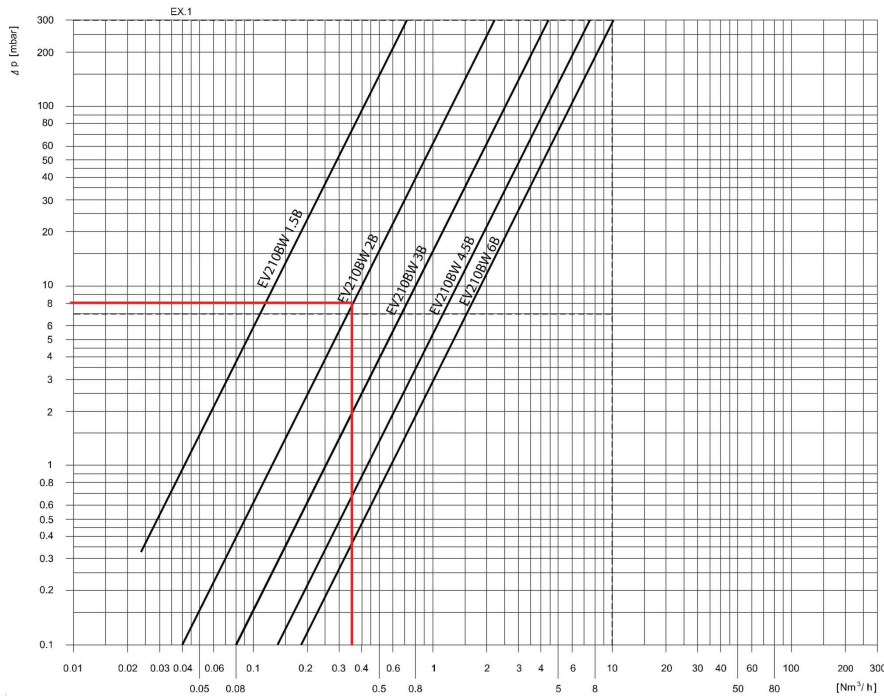

**Example, air at higher pressure:** Capacity for EV210BW 2B at inlet pressure ( $p_1$ ) of 5 bar and outlet pressure ( $p_2$ ) of 3.25 bar. Approx. 9 Nm<sup>3</sup> / h

**Figure: Air at higher pressure**

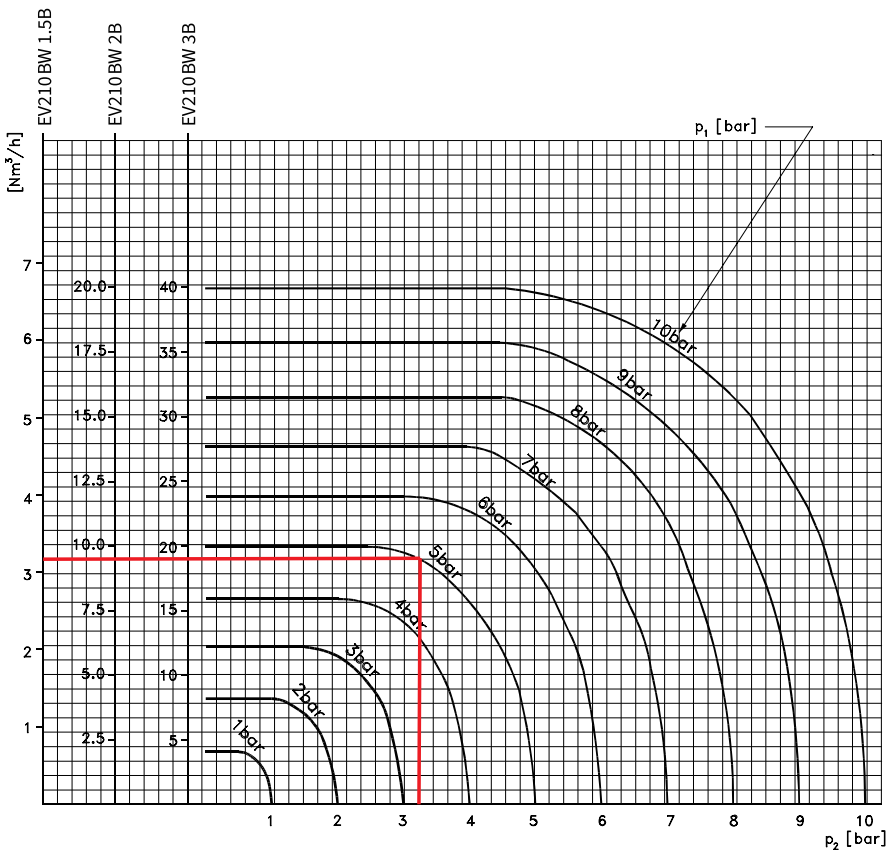

## Pressure and temperature data

Table: Differential pressure, NC

Connection ISO228-1	Orifice size	Differential pressure min. to max [bar]			
		NC			
		Suitable coils			
		BB/BE		BG	
		AC	DC	AC	DC
G $\frac{1}{8}$	1.5	0 – 10	0 – 10	0 – 10	0 – 10
G $\frac{1}{4}$	2.0	0 – 10	0 – 10	0 – 10	0 – 10
G $\frac{1}{4}$	3.0	0 – 10	0 – 10	0 – 10	0 – 10
G $\frac{1}{4}$ , G $\frac{3}{8}$	4.5	0 – 10	0 – 4.5	0 – 10	0 – 9
G $\frac{1}{4}$ , G $\frac{3}{8}$	6.0	0 – 4	0 – 2	0 – 6	0 – 4.5

Table: Differential pressure, NO

Connection ISO228-1	Orifice size	Differential pressure min. to max [bar]			
		NO			
		Suitable coils			
		BB/BE		BG	
		AC	DC	AC	DC
G $\frac{1}{8}$	1.5	0 – 10	0 – 10	0 – 10	0 – 10
G $\frac{1}{4}$	2.0	0 – 10	0 – 10	0 – 10	0 – 10
G $\frac{1}{4}$	3.0	0 – 5	0 – 5	0 – 5	0 – 5
G $\frac{1}{4}$ , G $\frac{3}{8}$	4.5	0 – 2	0 – 2	0 – 2	0 – 2

## Dimensions

Table: Dimensions and weight

Type	Weight gross valve body without coil	L [mm]	B [mm]	B <sub>1</sub> /coil type		H [mm]	H1 [mm]
	[kg]			BB/BE	BG		
EV210BW 1.5	0.15	35	34	46	68	12	70
EV210BW 2	0.15	35	34	46	68	12	70
EV210BW 3	0.20	38	34	46	68	11	70
EV210BW 4.5	0.20	38	34	46	68	11	70
EV210BW 6	0.22	46	34	46	68	16	73

Figure: Dimensions

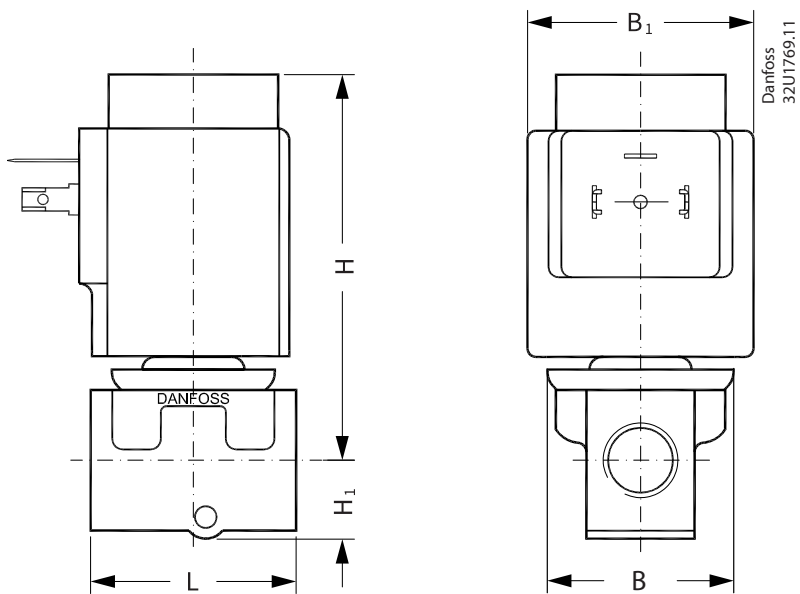

## Installation

Figure: Mounting angle

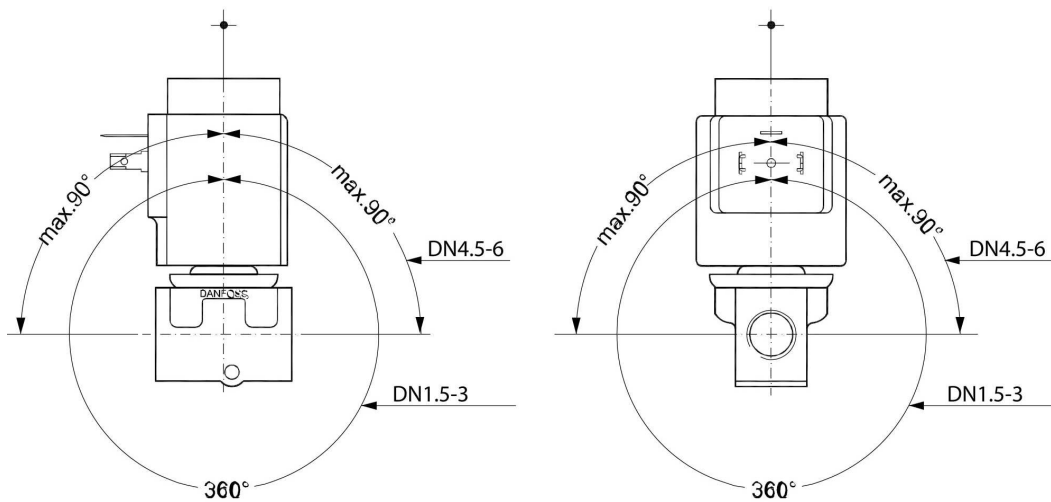

## Certificates, declarations and approvals

The list contains all certificates, declarations, and approvals for this product type. Individual code number may have some or all of these approvals, and certain local approvals may not appear on the list.

When you click on the link you will be directed to the latest version of the 'Declaration of Conformity'. Products developed and sold before this date of issue conform to the directives/standards in force at the time of their sale.

Approval type	Title	Certification body	Approval topic
Hygienic Certificate	<a href="#">PZH B-BK-60110-1266/2023</a>	PZH - National Institute of Hygiene	Drinking Water
Manufacturer's Declaration	<a href="#">Danfoss MD 033F0232.AA</a>	Danfoss	PED, Pressure
Hygienic Certificate	<a href="#">CARSO 24 ACC LY 130</a>	CARSO - Laboratoire Santé Environnement Hygiène de Lyon	Drinking Water
Hygienic Certificate	<a href="#">RISE SC0155-18</a>	RISE - Research Institute of Sweden AB	Drinking Water
Hygienic Certificate	<a href="#">SINTEF 3468</a>	SINTEF - SINTEF Byggforsk	Drinking Water
Manufacturer's Declaration	<a href="#">Danfoss MD 033F1135.00</a>	Danfoss	Drinking Water
Export Control Declaration	<a href="#">Solenoid valves – Polymer, Bronze, Brass, Cast iron</a>	Danfoss	
EU Declaration	<a href="#">Danfoss EU 033F0683.05</a>	Danfoss	LVD, EU RoHS
UA Declaration	<a href="#">Danfoss UA 8481</a>	Danfoss	UA RoHS
Mechanical Safety Certificate	<a href="#">UL MH7648</a>	UL - Underwriters Laboratories inc.	
Pressure Safety Certificate	<a href="#">LLC CDC EURO-TYSK</a> <a href="#">UA.TR.089.1015.02-22</a>	LLC CDC EURO TYSK - Ukraine	PED, Pressure
Manufacturer's Declaration	<a href="#">Danfoss MD 033F1140.01</a>	Danfoss	EU RoHS

## Drinking water approvals

### Figure: Rise



Valves are certified by RISE, notified body 1002. Valid in Denmark and Sweden. In accordance with Boverket Building Regulations (BBR 21, 2014-06-17) Certificate number SCO155-18

### Figure: SINTEF



Valves are certified by SINTEF. Valid in Norway. In accordance with NKB Product rules nr. 13, pkt. 3.2 – 3.6 :

- NT VVS 100, pkt. 6.4.2 & 6.4.8
- EN ISO 6509

### Figure: DTI



Inspection by DTI

### Figure: ACS



Valves are certified by Carso according to ACS guidelines, Circulaire 2002/571.

### Figure: PZH



Hygienic certificate B-BK-60210-1275/19. Issued by Polish National Institute of Public health (PZH).

Wetted materials in accordance with 4MS (4 member states Germany, Holland, France and UK), DVGW, BWGL, KTW and W270.

## Contact details

### Online support

Danfoss offers a wide range of support along with our products, including digital information, software, mobile apps and expert guidance. See the possibilities below.



#### The Danfoss Design center

Discover the Design Center, our advanced digital platform that streamlines product selection. With integrated tools and enhanced type pages, it's simpler than ever to access product information and documentation, and to select the right products. Check the availability of Danfoss products at partner locations and enjoy seamless transitions from selection to purchase with our basket-to-basket functionality. Whether you're buying from our distributors or directly from the Product Store, the Design Center simplifies your experience. Learn more at: [designcenter.danfoss.com](https://designcenter.danfoss.com).



#### The Danfoss product store

The Danfoss Product Store is a one-stop shop available 24/7 for our customers, no matter where you are in the world or what area of industry you work in. Browse our catalog, check product details and documentation, view your prices and product availability, and quickly finalize your purchase. Start browsing at: [store.danfoss.com](https://store.danfoss.com).



#### Danfoss Partner Portal/Product Data tool

Designed to support you with easy access to product data extracts, essential resources, tools, and information. The Partner Portal provides a centralized hub for product documentation, training materials, marketing assets, and technical support, ensuring you have everything you need to succeed and grow your business with Danfoss. The Partner Portal is available 24/7 at: [partner.danfoss.com](https://partner.danfoss.com) and is ready to support your business.



#### Find technical documentation

Find technical documentation you need to get your project up running. Get direct access to our official collection of data sheets, certificates and declarations, manuals and guides, 3D models and drawings, case stories, brochures, and much more. Start searching now at: [documentation.danfoss.com](https://documentation.danfoss.com).



#### Danfoss Learning

Danfoss Learning is a free online learning platform. It features courses and materials specifically designed to help engineers, installers, service technicians, and wholesalers better understand the products, applications industry topics, and trends that will help you do your job better. Find your local Danfoss website here: [learning.danfoss.com](https://learning.danfoss.com).



#### Get local information and support

Local Danfoss websites are the main sources for help and information about our company and products. Find product availability, get the latest regional news, or connect with a nearby expert - all in your own language. Find your local Danfoss website here: [danfoss.com](https://danfoss.com).

#### Danfoss A/S

Climate Solutions . danfoss.com . +45 7488 2222

---

Any information, including, but not limited to information on selection of product, its application or use, product design, weight, dimensions, capacity or any other technical data in product manuals, catalogues description, advertisements, etc. and whether made available in writing, orally, electronically, online or via download, shall be considered informative, and is only binding if and to the extent, explicit reference is made in a quotation or order confirmation. Danfoss cannot accept any responsibility for possible errors in catalogues, brochures, videos and other material. Danfoss reserves the right to alter its products without notice. This also applies to products ordered but not delivered provided that such alterations can be made without changes to form, fit or function of the products. All trademarks in this material are property of Danfoss A/S or Danfoss group companies. Danfoss and the Danfoss logo are trademarks of Danfoss A/S. All rights reserved.

---